

PD IEC/TR 62750:2011



BSI Standards Publication

Unified fluorescent lamp dimming standard calculations

bsi.

...making excellence a habit.™

National foreword

This Published Document is the UK implementation of IEC/TR 62750:2011.

The UK participation in its preparation was entrusted by Technical Committee CPL/34, Lamps and Related Equipment, to Subcommittee CPL/34/1, Electric lamps.

A list of organizations represented on this committee can be obtained on request to its secretary.

This publication does not purport to include all the necessary provisions of a contract. Users are responsible for its correct application.

© The British Standards Institution 2012

Published by BSI Standards Limited 2012

ISBN 978 0 580 76647 3

ICS 29.140

Compliance with a British Standard cannot confer immunity from legal obligations.

This Published Document was published under the authority of the Standards Policy and Strategy Committee on 31 March 2012.

Amendments issued since publication

Amd. No.	Date	Text affected
-----------------	-------------	----------------------



TECHNICAL REPORT

Unified fluorescent lamp dimming standard calculations

INTERNATIONAL
ELECTROTECHNICAL
COMMISSION

PRICE CODE

R

ICS 29.140

ISBN 978-2-88912-939-3

Warning! Make sure that you obtained this publication from an authorized distributor.

CONTENTS

FOREWORD.....	3
1 Scope.....	5
2 Explanation of the dimming requirements	5
2.1 General.....	5
2.2 Additional heating.....	5
2.3 Cathode heating limits.....	6
2.4 Substitution resistors for electronic controlgear qualification.....	7
3 Determination of limit values	8
3.1 General.....	8
3.2 Minimum sum-of-squares – $SoS_{\min} (I_{D30} \leq I_D < I_{Dtrans})$	9
3.2.1 Lamp and electronic controlgear systems – SoS'_{\min}	9
3.2.2 Electronic controlgear qualification limits – SoS_{\min}	11
3.3 Minimum cathode voltage – $CV_{\min} (I_{Dmin} \leq I_D < I_{D30})$	12
3.3.1 Lamp and electronic controlgear systems – CV'_{\min}	12
3.3.2 Electronic controlgear qualification limits – CV_{\min}	12
3.4 Maximum cathode voltage – $CV_{\max} (I_{Dmin} \leq I_D < I_{Dtrans})$	13
3.4.1 Lamp and electronic controlgear systems – CV'_{\max}	13
3.4.2 Electronic controlgear qualification limits – CV_{\max}	14
4 Example of calculation for 54W HO lamps	14
4.1 General.....	14
4.2 Calculation of lamp and ECG systems – SoS'_{\min}	15
4.3 Calculation of lamp and ECG systems – CV'_{\min}	15
4.4 Calculation of ECG qualification limits – CV_{\min}	16
4.5 Calculation of lamp and ECG systems – CV'_{\max}	16
4.6 Calculation of ECG qualification limits – CV_{\max}	16
5 Glossary of symbols	17
Bibliography.....	20
Figure 1 – Fundamental circuit for SoS test	10
Table 1 – SoS parametric values	9
Table 2 – Fitted power law parameters	11
Table 3 – Informative parameters for lamp and controlgear systems	13
Table 4 – Datasheet parameters	14

INTERNATIONAL ELECTROTECHNICAL COMMISSION

UNIFIED FLUORESCENT LAMP DIMMING STANDARD CALCULATIONS

FOREWORD

- 1) The International Electrotechnical Commission (IEC) is a worldwide organization for standardization comprising all national electrotechnical committees (IEC National Committees). The object of IEC is to promote international co-operation on all questions concerning standardization in the electrical and electronic fields. To this end and in addition to other activities, IEC publishes International Standards, Technical Specifications, Technical Reports, Publicly Available Specifications (PAS) and Guides (hereafter referred to as "IEC Publication(s)"). Their preparation is entrusted to technical committees; any IEC National Committee interested in the subject dealt with may participate in this preparatory work. International, governmental and non-governmental organizations liaising with the IEC also participate in this preparation. IEC collaborates closely with the International Organization for Standardization (ISO) in accordance with conditions determined by agreement between the two organizations.
- 2) The formal decisions or agreements of IEC on technical matters express, as nearly as possible, an international consensus of opinion on the relevant subjects since each technical committee has representation from all interested IEC National Committees.
- 3) IEC Publications have the form of recommendations for international use and are accepted by IEC National Committees in that sense. While all reasonable efforts are made to ensure that the technical content of IEC Publications is accurate, IEC cannot be held responsible for the way in which they are used or for any misinterpretation by any end user.
- 4) In order to promote international uniformity, IEC National Committees undertake to apply IEC Publications transparently to the maximum extent possible in their national and regional publications. Any divergence between any IEC Publication and the corresponding national or regional publication shall be clearly indicated in the latter.
- 5) IEC itself does not provide any attestation of conformity. Independent certification bodies provide conformity assessment services and, in some areas, access to IEC marks of conformity. IEC is not responsible for any services carried out by independent certification bodies.
- 6) All users should ensure that they have the latest edition of this publication.
- 7) No liability shall attach to IEC or its directors, employees, servants or agents including individual experts and members of its technical committees and IEC National Committees for any personal injury, property damage or other damage of any nature whatsoever, whether direct or indirect, or for costs (including legal fees) and expenses arising out of the publication, use of, or reliance upon, this IEC Publication or any other IEC Publications.
- 8) Attention is drawn to the Normative references cited in this publication. Use of the referenced publications is indispensable for the correct application of this publication.
- 9) Attention is drawn to the possibility that some of the elements of this IEC Publication may be the subject of patent rights. IEC shall not be held responsible for identifying any or all such patent rights.

The main task of IEC technical committees is to prepare International Standards. However, a technical committee may propose the publication of a technical report when it has collected data of a different kind from that which is normally published as an International Standard, for example "state of the art".

IEC 62750, which is a technical report, has been prepared by subcommittee 34A: Lamps, of IEC technical committee 34: Lamps and related equipment.

The text of this technical report is based on the following documents:

Enquiry draft	Report on voting
34A/1511/DTR	34A/1546/RVC

Full information on the voting for the approval of this technical report can be found in the report on voting indicated in the above table.

This publication has been drafted in accordance with the ISO/IEC Directives, Part 2.

The committee has decided that the contents of this publication will remain unchanged until the stability date indicated on the IEC web site under "<http://webstore.iec.ch>" in the data related to the specific publication. At this date, the publication will be

- reconfirmed,
- withdrawn,
- replaced by a revised edition, or
- amended.

A bilingual version of this publication may be issued at a later date.

UNIFIED FLUORESCENT LAMP DIMMING STANDARD CALCULATIONS

1 Scope

This Technical Report applies to fluorescent lamp dimming systems. It deals with the interface of fluorescent lamps and dimming electronic controlgear. A unified framework for standardization of fluorescent lamp dimming systems and the associated parameter calculation method are described in this Technical Report.

Dimming of fluorescent lamps is becoming increasingly important as a strategy for conserving global energy resources. This report is the result of many years of effort by global experts to understand and test fluorescent dimming systems with the objective of standardizing these systems to grow confidence and reliability in the marketplace. Two theoretical frameworks have been merged to create this unified dimming standardization method: the SoS (sum of squares of lead-in-wire currents) and CV (cathode voltage) models. The application of dimming to actual fluorescent lamp and electronic controlgear (ECG) systems is the primary concern for reliability in the application and end-user confidence. Characteristics of the dimming parameter limits described in this report and observed in real system applications such as in situ field diagnostics are offered as informative. The practical need to use substitution resistors for ECG qualification is described in this report and also given as normative parameters in the lamp and ECG standards. No attempt to treat the informative real lamp-ECG system parameters as normative will be made in either the lamp or the controlgear standards.

2 Explanation of the dimming requirements

2.1 General

This clause gives a general explanation of the dimming requirements found in the fluorescent lamp and controlgear standards. Subclause 2.2 provides an overview of the theoretical framework for the unified dimming standard. Subclause 2.3 provides an explanation of informative limits for the cathode heating based on physical lamp and ECG systems. Subclause 2.4 provides the basis for normative controlgear qualification using substitution resistors. In this Technical Report, the use of primed quantities will signify values obtained when measuring on actual fluorescent lamp and ECG systems. Unprimed quantities refer to standardised quantities when testing ECG on substitution resistors. Although lead wire and lamp discharge currents pertain to actual lamps, they will remain unprimed quantities in this report.

2.2 Additional heating

It is a well-known fact that, when lowering the lamp current to decrease the luminous flux (dimming) below a certain current value, the cathode is not heated sufficiently any more by the lamp current. At these dimmed conditions without added ohmic heating, the cathode fall will increase to sustain the lamp current and this results in an increased sputtering of the cathode and thereby a decrease in lamp life. So additional cathode heating is necessary to keep the cathode at a sufficiently high temperature for thermionic emission. The amount of this additional heating current through the cathodes as a function of the lamp current is however dependent on the controlgear circuit layout. There may be a phase shift between these currents like in circuits with a capacitor parallel to the lamp. In other circuits, the additional heating current is delivered by separate heating sources, in which case it is not clear through which lead-in wire which part of the lamp current flows. For a generalized description, these different circuits are included when describing the controlgear requirements.

It has been found that measuring the root mean square (r.m.s.) currents through the two lead-in wires to the cathode and calculating the sum of the mean squares of these two currents as a function of the discharge current can estimate the cathode heating. The sum of squares, SoS' , needed to keep the cathode at a sufficient temperature, is found to have a linear dependence on the root mean square (r.m.s.) discharge current:

$$SoS' = I_{LH}^2 + I_{LL}^2 = X'_1 - Y'_1 \times I_D$$

where

I_D is the discharge current;

I_{LH} is / lead high, which is the highest current through either lead-in wire;

I_{LL} is / lead low, which is the lowest current through either lead-in wire.

Alternatively, it has also been found that it is possible to describe cathode heating in terms of root mean square (r.m.s.) voltage applied across the cathode, CV' , while dimming. To a reasonable approximation in the deep dimming range, the voltage necessary to keep the cathode at a sufficient temperature is also a linear function of the root mean square (r.m.s.) discharge current,

$$CV' = X'_3 - Y'_3 \times I_D,$$

where the coefficients X'_3 and Y'_3 are constants, different from X'_1 and Y'_1 in the SoS' expression.

The dimming range of discharge currents for which additional heating is necessary is given by a maximum value, I_{Dtrans} , which defines the transition between normal and dimming operation, and a minimum value, I_{Dmin} , specified in the lamp standard. These values are expressed relative to the cathode test current, I_{test} , designated in the relevant IEC datasheets. This cathode test current is defined in the relevant IEC standard as the current to be applied when measuring the cathode hot resistance. An indirect measure related to the overall cathode temperature is the ratio, R_h/R_c , where R_h is the “hot” resistance during operation and R_c is the “cold” resistance at 25 °C. For a nominally performing filament, the measured hot resistance will usually correspond to a hot-to-cold resistance ratio, R_h/R_c , of 4,75. The range of discharge currents, $I_{Dmin} \leq I_D \leq I_{Dtrans}$, specified for dimming is typically $\sim 10\%$ of $I_{test} \leq I_D \leq \sim 80\%$ of I_{test} for many lamp designs¹. For discharge currents above the dimming range, $I_D \geq I_{Dtrans}$, additional cathode heating is not required, but not forbidden as long as the value for the maximum current in any lead, I_{LHmax} , is observed. Explicit values for the dimming range of discharge current and cathode test current are specified in the lamp datasheets.

2.3 Cathode heating limits

The SoS model is developed from assumptions about the cathode hot spot. This is the location where the discharge arc attaches to the electron-emitting region of the cathode. As the discharge current is lowered into the dimming region, a hot spot remains localized until the lamp current is lowered below I_{D30} , approximately 30 % of I_{test} . In this region of dimming where the lamp current is greater than or equal to I_{D30} , values for the critical “minimum SoS ” (SoS'_{min}) are set to prevent cathode sputtering and the resulting short lamp life.

At low dimming currents, the discharge attachment becomes diffusely attached to the cathode and the hot spot no longer is localized or stationary. Also, the hot spot tends to lose a well-defined location when high or excessive heating currents are applied to the cathode.

¹ It is important to note that I_{test} is defined as a cathode related current parameter and does not necessarily relate to the lamp discharge current or the dimming range for lamp designs in some regions.

Therefore, at low currents, or to describe the upper boundary of acceptable cathode heating, the CV becomes a preferred approach to standardizing the cathode-heating requirement. In the region of dimming where the lamp current is lowered below I_{D30} , values for the minimum cathode voltage, CV_{\min} , are set to prevent premature cathode destruction by sputtering.

Excessive additional heating will result in overheating of the cathode and thereby accelerated end blackening of the lamp. To protect the cathode from overheating, resulting in excessive barium evaporation (end-blackening) and possible mercury starvation in the lamp, a maximum heating level should be set for the cathode voltage. This maximum cathode voltage, CV_{\max} , is set to limit the cathode temperature below a temperature typically corresponding to a cathode resistance ratio of $R_h/R_c < 5,2$.

The uncoated part of the cathode can be overheated by the combination of high additional heating and the discharge current itself (mainly in the higher dimming region). Setting a maximum, $I_{LH\max}$, to the higher lead-in wire current, I_{LH} , will protect these parts of the cathodes.

For controlgear design guidance, a target line SoS'_{tgt} is also defined. It is a best setting for the cathode heating to be sufficiently far away from the critical minimum and maximum.

To summarize, the cathode heating informative limits are given by the following set of criteria uniquely defined over the dimming region of lamp currents. The voltage measured across the leads of each cathode in the system should generally lie above the minimum heating line CV_{\min} and below the maximum heating limit CV_{\max} . The measured SoS current values should lie above the minimum line SoS'_{\min} and the measured lead-in wire currents shall not exceed the $I_{LH\max}$ limit.

Lower limit:	$SoS'_{\min} [I_{LH}^2 + I_{LL}^2] = X'_1 - Y'_1 \times I_D$	for $I_{D30} \leq I_D < I_{Dtrans}$
Lower limit:	$CV_{\min} = X'_3 - Y'_3 \times I_D$	for $I_{Dmin} \leq I_D < I_{D30}$
Upper limit:	$CV_{\max}, I_{LH\max}$	for $I_{Dmin} \leq I_D < I_{Dtrans}$
Target:	$SoS'_{tgt} [I_{LH}^2 + I_{LL}^2] = X'_1 - 0,3Y'_1 \times I_D$	

2.4 Substitution resistors for electronic controlgear qualification

For normative ECG testing, the lamp discharge impedance is approximated using substitution resistors, R_L , having values (R_{L10min} , R_{L10max} , R_{L30} and R_{L60}) given at 10 %, 30 % and 60 % of the test current, I_{test} . Ambient temperature and lamp geometry are known to have a major influence on the lamp impedance. At $I_D = I_{Dmin}$ a minimum, R_{L10min} , and maximum value, R_{L10max} , of the lamp substitution resistance is specified to allow for a rough approximation of the thermal dependency of the lamp impedance. These resistor values are set at –30 % and + 30 % of the nominal lamp impedance at $I_D = I_{Dmin}$. At $I_D = 30\%$ (I_{D30}) and 60 % (I_{D60}) of I_{test} , the nominal value of the lamp impedance is specified for the substitution resistance value. These discharge current values have been chosen in the dimmed region where proper setting of electrode heating is important for reliable lamp operation throughout the rated lamp life. To summarize the lamp discharge substitution resistor set, the following abbreviations are used:

- low impedance discharge at I_{Dmin} : R_{L10min} ;
- high impedance discharge at I_{Dmin} : R_{L10max} ;
- discharge impedance at I_{D30} : R_{L30} ;
- discharge impedance at I_{D60} : R_{L60} .

For any ECG that does not operate with a continuous range of dimming current (e.g. step dimming controlgear), the lamp substitution resistor is selected to approximate the lamp discharge impedance. This impedance approximation uses linear interpolations for R_{Lmin} from R_{L10min} to R_{L30} , R_{Lmax} from R_{L10max} to R_{L30} , and R_L from R_{L30} to R_{L60} for the range of lamp discharge current from $I_{Dmin} \leq I_D < I_{Dtrans}$ in this report,

$$R_L = \frac{(R_{L60} - R_{L30})}{(I_{D60} - I_{D30})} \cdot (I_D - I_{D30}) + R_{L30} \quad \text{for } I_{D30} < I_D < I_{Dtrans}$$

$$R_{Lmin} = \frac{(R_{L10min} - R_{L30})}{(I_{Dmin} - I_{D30})} \cdot (I_D - I_{D30}) + R_{L30} \quad \text{for } I_{Dmin} \leq I_D < I_{D30}$$

$$R_{Lmax} = \frac{(R_{L10max} - R_{L30})}{(I_{Dmin} - I_{D30})} \cdot (I_D - I_{D30}) + R_{L30} \quad \text{for } I_{Dmin} \leq I_D < I_{D30}$$

The selected resistor shall have a resistance value within 20 % of the calculated R_{Lmin} , R_{Lmax} , or R_L value for the lamp operating current of the ECG under test. For normative ECG, qualification test conditions are specified in IEC 60929.

In addition, the cathode impedance is approximated with substitution resistors. Since the heating characteristics of resistors $P \sim V^2$ or $P \sim I^2$, differ significantly from actual cathodes, $P \sim V^{1.4}$ or $P \sim I^{3.2}$, three substitution resistance values, R_{test1} , R_{test2} , and R_{test3} , are given for each cathode for controlgear qualification tests. The R_{test1} value, chosen to account for typical cathode impedance variation and provide most cathodes with moderate auxiliary heating $R_h/R_c \geq 4,3$ is used when testing the lower cathode-heating limit, SoS_{min} . The R_{test1} value is approximately equal to 4,6 R_c for typical T5 cathodes. Nevertheless, as a rule of thumb, R_{test1} should be chosen on the order of 4,75 R_c . Note that, due to the selection of R_{test1} values exceeding the typical cathode impedance, values for cathode heating limits will differ from the informative physical lamp-ECG system values when qualifying ECG on substitution resistors. The R_{test2} value, chosen to approximate the cathode impedance with a high level of auxiliary heating $R_h/R_c \sim 5,2$, is used when testing the upper cathode-heating limit, CV_{max} and I_{LHmax} . The R_{test3} value is chosen to approximate the typical cathode impedance when heated only with auxiliary current to a temperature corresponding to $R_h/R_c \sim 4,3$. The R_{test3} substitution resistor is used when testing ECG for the lower cathode heating limit, CV_{min} , at the deepest dimming lamp currents that provide only negligible heating from the discharge current. This selection of R_{test3} is the most accurate representation of the typical cathode at the deep dimming current and therefore provides a robust test of ECG that may use different cathode heating circuit topologies.

The normative qualification of ECG is specified only at the values of cathode substitution resistances defined above, not continuously along the lamp current dimming curve. Related to these values, a test procedure and a test circuit are given in the performance standard for electronic controlgear, IEC 60929.

3 Determination of limit values

3.1 General

This clause provides the details by which the limit values for SoS and CV are determined. It is important to keep in mind that the lamp discharge and cathode substitution resistor values as well as the limit criteria for normative testing of ECG are negotiated quantities. The values are set taking typical sources of cathode and lamp variation into account to provide reliable dimming for compliant ECG operating in real systems. When developing normative limits for the unified dimming standard, special care is taken to match the auxiliary heat delivered to a typical cathode at I_{D30} by the SoS'_{min} and CV'_{min} informative limit lines for the lamp and controlgear system. A discontinuity in delivered auxiliary heat between these cathode heating

limit lines should be avoided for practical system design. Due to the selection criteria of substitution resistors for controlgear qualification (see 2.4) comparisons of the normative quantities (SoS_{min} , CV_{min} and CV_{max}) with informative quantities (SoS'_{min} , CV'_{min} and CV'_{max}) will result in apparent discontinuities. This clause is divided into three subclauses. Subclause 3.2 explains the derivation of the minimum SoS limits. Subclauses 3.3 and 3.4 describe the procedure for setting minimum and maximum CV limits respectively. Each description builds from practical limits for the cathode heating based on physical lamp and ECG systems to explain how the normative limits are determined for ECG qualification using substitution resistors.

3.2 Minimum sum-of-squares – SoS_{min} ($I_{D30} \leq I_D < I_{Dtrans}$)

Establishment of minimum auxiliary heating limits in the hot spot region begins with the parametric values for the sum-of-squares (SoS) model. In this model, the values for the lamp current range, $I_{D30} \leq I_D < I_{Dtrans}$, and for the SoS constants are coupled to the cathode test current, I_{test} , at which a cathode reaches a specified resistance and temperature, given by $R_h/R_c \sim 4,75$. These parametric values were determined through examination of reliability testing data and are considered applicable to many lamp designs. Table 1 gives approximate mathematical expressions for these parameters.

Table 1 – SoS parametric values

Minimum dimming discharge current, I_{Dmin}		$\approx 0,1 I_{test}$
Maximum dimming discharge current, I_{Dtrans}		$\approx 0,8 I_{test}$
Lower limit of auxiliary heating	$SoS_{min}: I_{LH}^2 + I_{LL}^2 = X_1 - Y_1 \times I_D$	$X_1 \approx 1,8 I_{test}^2, Y_1 \approx 1,85 I_{test}$
Target	$SoS_{tgt}: I_{LH}^2 + I_{LL}^2 = X_1 - 0,3 Y_1 \times I_D$	$X_1 \approx 1,8 I_{test}^2, Y_1 \approx 1,85 I_{test}$

3.2.1 Lamp and electronic controlgear systems – SoS'_{min}

Since dimming operation is intended for actual physical lamps on ECG, system cathode heating limits for $SoS'_{min}: I_{LH}^2 + I_{LL}^2 = X'_1 - Y'_1 \times I_D$ over the dimming range above I_{D30} are desired for informative purposes. The selection of the cathode substitution resistor, R_{test1} , sets the cathode heating normative ECG requirement in the SoS model. As noted in 2.4, the selection of R_{test1} to account for cathode resistance variation results in differences between the normative SoS heating limit and the heating of actual cathodes in lamps operating on the same ECG. Values for the coefficients X'_1 and Y'_1 are determined through a transformation from the substitution resistor network to the lamp-ECG system. Since the auxiliary heat delivered to the cathode is the fundamental parameter that maintains thermionic emission under dimming conditions (see 2.2), it will be maintained invariant in the transformation. To carry out this transformation, it is important to know the characteristics of typical cathodes. A maximum lead wire resistance, R_{LW} , is specified in the lamp standard datasheets to minimize the biasing effect on the delivered auxiliary heat. Therefore, lead wire resistance is considered negligible for this calculation. The following is a detailed description of the transformation.

In the SoS model, the lead wire currents, I_{11} , I_{12} , I_{21} and I_{22} , consist of two components: the auxiliary heating current and the lamp discharge current that also contributes to the heating of the cathode. Similarly for the fundamental test circuit (see Figure 1) that simulates lamp conditions using substitution resistors and is specified for ECG qualification, the total heat delivered to the cathode substitution resistor, R_{test1} , is considered to have two components: the auxiliary heat and the lamp discharge current heat.

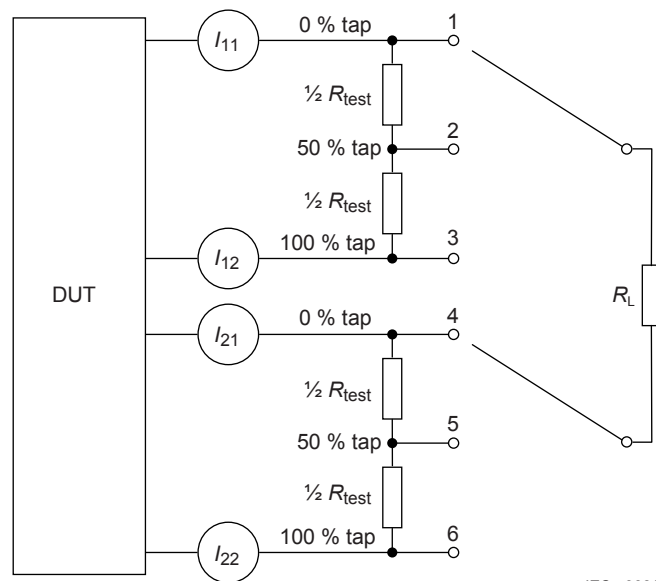

IEC 238/12

Key

- DUT Controlgear device under test
- RL Lamp substitution resistor
- I_{ij} measured current in j^{th} lead of the i^{th} simulated cathode
- 1...6 Switch positions

Figure 1 – Fundamental circuit for SoS test

Thus, the auxiliary heat delivered to the cathode substitution resistor, R_{test1} , under conditions at $I_D = I_{D30}$ is calculated by subtracting the lamp current heat portion from the total delivered heat as specified by the SoS_{min} line (SoS_{30}) limit in the lamp datasheet. In the test circuit, each cathode is replaced by two “half” resistors of value equal to $\frac{1}{2} R_{\text{test1}}$. This allows simulation of various arc attachment points during ECG qualification. The central attachment point (50 % tap) is used for this transformation². Thus, the lamp current, I_D , will split equally between the two leads and the heating contribution to the cathode substitution resistor pair is $\frac{1}{4} I_D^2 \times R_{\text{test1}}$. Subtracting this from the total SoS delivered heat gives the minimum delivered auxiliary heat at $I_D = I_{D30}$.

$$\text{Heat aux}_{30} = \frac{1}{2} \text{SoS}_{30} \times R_{\text{test1}} - \frac{1}{4} I_{D30}^2 \times R_{\text{test1}}$$

Next, the cathode heating characteristics are determined from measurements of commercially available lamps. From suitable parametric fits ($a1, b1$), ($a2, b2$) and ($a3, b3$) to power law regressions of the combined cathode data from several manufacturers, the following relations are determined,

$$\begin{aligned} I &= a1 \times V^{b1}, \\ V &= a2 \times P^{b2}, \\ R_h/R_c &= a3 \times V^{b3}, \end{aligned}$$

where I , V , and P , are the cathode current, voltage, and power, respectively.

² Note that for real lamps and controlgears, when a hot spot is present, the arc attachment points and the phase angle between lamp current and auxiliary heating current can vary. As a result, the cathode heating power can vary.

The parameters $a1...a3$ are multiplicative scalars and $b1...b3$ are exponents. A summary of these experimentally determined power law fitted parameters for T5 HE (high efficiency) and T5 HO (high output) cathodes is presented in Table 2.

Table 2 – Fitted power law parameters

T5 cathode	$I = a1 \times V^{b1}$		$V = a2 \times P^{b2}$		$R_h/R_c = a3 \times V^{b3}$	
	$a1$	$b1$	$a2$	$b2$	$a3$	$b3$
14, 21, 28, 35W HE	0,069 4	0,446 1	6,324 9	0,691 4	1,704 9	0,547 8
24, 39W HO	0,192 2	0,370 8	3,330 1	0,729 5	2,001 0	0,628 7
49W HO	0,137 6	0,417 3	4,053 4	0,705 5	1,953 9	0,582 5
54W HO	0,271 6	0,437 8	2,475 9	0,695 4	2,288 3	0,560 8
80W HO	0,283 2	0,444 0	2,395 7	0,692 5	2,422 5	0,566 0

These relations are now used to transform the auxiliary heat invariant into cathode parameters for the lamp-ECG dimming system. Specifically, the cathode voltage, CV'_{min30} , that delivers the same auxiliary heat is

$$CV'_{min30} = a2 [Heat\ aux_{30}]^{b2}$$

This in turn is used to calculate the cathode current, I'_{min30} , that delivers the same minimum auxiliary heat,

$$I'_{min30} = a1 [CV'_{min30}]^{b1}$$

The minimum sum-of-squared lead currents, SoS'_{30} , at I_{D30} for the lamp-ECG system is then calculated as follows.

$$SoS'_{30} = I_{LH}^2 + I_{LL}^2 = (I_{min30} + \frac{1}{2} I_{D30})^2 + (I_{min30} - \frac{1}{2} I_{D30})^2 = 2 I_{min30}^2 + \frac{1}{2} I_{D30}^2$$

With this result, the rest of the informative SoS'_{min} limit is determined by constructing the line joining the point (I_{D30}, SoS'_{30}) to the point $(I_{Dtrans}, \frac{1}{2} I_{Dtrans}^2)$ where no auxiliary heat is required.

$$SoS'_{min} [I_{LH}^2 + I_{LL}^2] = X'_1 - Y'_1 \times I_D \quad \text{for } I_{D30} \leq I_D < I_{Dtrans}$$

With the coefficients given by

$$X'_1 = \frac{1}{2} I_{Dtrans}^2 + Y'_1 \times I_{Dtrans}$$

$$Y'_1 = [SoS'_{30} - \frac{1}{2} I_{Dtrans}^2] / [I_{Dtrans} - I_{D30}]$$

The values of these coefficients together with the equation for the minimum sum-of-squares lead currents are given as informative parameters in Table 3.

3.2.2 Electronic controlgear qualification limits – SoS_{min}

As explained in 2.4, normative qualification of ECG is specified using a simulated lamp circuit and SoS_{min} limit values. The SoS_{min} limit parameters (I_{test}, X_1, Y_1) applicable to testing ECG on the circuit network of substitution resistors (R_{test1} , R_{L30} , and R_{L60}) are negotiated consensus values and specified in the lamp datasheets. Since the normative qualification limits for continuous range dimming ECG are specified at I_{D30} and I_{D60} , the lamp datasheets specify the values of SoS_{min} explicitly at these values of lamp operating current.

Normative ECG qualification testing of dimming controlgear is described in IEC 60929. For lamp currents within the SoS region ($I_{D30} \leq I_D < I_{Dtrans}$), determine the SoS_{min} : $I_{LH}^2 + I_{LL}^2 = X_1 - Y_1 \times I_D$ specification using values of the coefficients X_1 and Y_1 taken from the lamp datasheets. The resistor substitution network (R_{test1} and R_L) shall use the lamp substitution resistor, R_L , as determined from 2.4 and the lamp datasheets. The measured values of the substitution resistor network sum-of-squares lead currents $I_{LH}^2 + I_{LL}^2$ shall exceed the specified value of SoS_{min} at each test condition for the ECG to qualify. Test conditions are specified in the ECG standard.

3.3 Minimum cathode voltage – CV_{min} ($I_{Dmin} \leq I_D < I_{D30}$)

3.3.1 Lamp and electronic controlgear systems – CV'_{min}

Setting the informative lamp-ECG system values for the minimum cathode heating in the deep dimming region begins with the expectation that cathodes will be designed to be thermionically emissive when heated above a temperature corresponding to $R_h/R_c \sim 4,3$. The slope and y-intercept of the CV'_{min} limit line are specified to construct a line that requires delivery of the same invariant cathode heat at $I_D = I_{D30}$ as the SoS'_{30} limit and with a point at (I_{Dmin}, CV'_{min10}) that heats the cathode to $R_h/R_c \sim 4,3$. To construct this limit, the cathode heating characteristics (see 3.2.1) are used to calculate the cathode voltage required for $R_h/R_c = 4,3$ at $I_D = I_{Dmin}$,

$$CV'_{min10} = [(R_h/R_c)/a3]^{(1/b3)} = [4,3 / a3]^{(1/b3)}$$

The minimum cathode voltage limit line is then determined as follows:

$$CV'_{min} = X'_3 - Y'_3 \times I_D \quad \text{for } I_{Dmin} \leq I_D < I_{D30}$$

With the coefficients given by

$$\begin{aligned} X'_3 &= CV'_{min30} + Y'_3 \times I_{D30} \\ Y'_3 &= [CV'_{min10} - CV'_{min30}] / [I_{D30} - I_{Dmin}] \end{aligned}$$

The values of these coefficients together with the equation for the minimum cathode voltage are given as informative parameters in Table 3.

3.3.2 Electronic controlgear qualification limits – CV_{min}

The calculation of the normative minimum cathode voltage for ECG qualification on the specified resistor substitution network (R_{test3} , R_{L10min} and R_{L10max}) begins by transforming the informative minimum cathode voltage limit line, $CV'_{min} = X'_3 - Y'_3 \times I_D$, for lamp-ECG systems into a cathode voltage limit line equation for substitution resistor networks, $CV_{min} = X_3 - Y_3 \times I_D$. To begin, the cathode heating characteristics (see 3.2.1) are used to determine the minimum cathode power with no lamp current, P'_{min0} ,

$$P'_{min0} = [X'_3 / a2]^{(1/b2)}$$

This minimum heating power is then applied to the specified substitution resistor R_{test3} and the resulting resistor voltage, V_{min0} , is calculated:

$$V_{min0} = [R_{test3} \times P'_{min0}]^{(1/2)}$$

The invariant minimum delivered auxiliary cathode heat at $I_D = I_{D30}$ is then used to calculate a voltage, $V_{\min30}$, for the substitution resistor $R_{\text{test}3}$ at I_{D30} ,

$$V_{\min30} = [R_{\text{test}3} \times \text{Heat aux}_{30}]^{(1/2)}$$

The transformed voltage limit equation is now determined,

$$CV_{\min} = X_3 - Y_3 \times I_D$$

With the coefficients given by

$$X_3 = V_{\min0}$$

$$Y_3 = [V_{\min0} - V_{\min30}] / I_{D30}$$

The minimum cathode voltage, $CV_{D\min}$ for the substitution resistor at $I_{D\min}$ is given by

$$CV_{D\min} = X_3 - Y_3 \times I_{D\min}$$

This value is specified as normative for ECG qualification in the lamp datasheets. This $CV_{D\min}$ limit specification applies also for normative ECG qualification testing of non-continuous or continuous range dimming controlgear that achieve lowest current levels below $(I_{D\min} + I_{D30})/2$ but do not reach I_D currents as low as $I_{D\min}$. The ECG shall be tested at the lowest current setting available without adjustment of the $CV_{D\min}$ limit or the substitution resistor network ($R_{\text{test}3}$, $R_{L10\min}$ and $R_{L10\max}$) for normative qualification.

3.4 Maximum cathode voltage – CV_{\max} ($I_{D\min} \leq I_D < I_{D\text{trans}}$)

3.4.1 Lamp and electronic controlgear systems – CV'_{\max}

The maximum cathode heating limit for the informative lamp-ECG system is determined from the cathode heating characteristics (see 3.2.1) by calculating the cathode voltage required for $R_h/R_c = 5,2$ at all lamp current values in the dimming range, $I_{D\min} \leq I_D < I_{D\text{trans}}$. Thus,

$$CV'_{\max} = [(R_h/R_c)/a3]^{(1/b3)} = [5,2 / a3]^{(1/b3)}$$

This value of the maximum cathode voltage is specified as an informative parameter in Table 3.

Table 3 – Informative parameters for lamp and controlgear systems

T5 cathode	I_{test}	SoS'_{\min} ($I_{D30} \leq I_D < I_{D\text{trans}}$)		CV'_{\min} ($I_{D\min} \leq I_D < I_{D30}$)		CV'_{\max} ($I_{D\min} \leq I_D < I_{D\text{trans}}$)
		X'_1	Y'_1	X'_3	Y'_3	
14, 21, 28, 35W HE	0,160	0,059	0,387	5,89	22,89	7,65
24, 39W HO	0,350	0,251	0,796	3,63	7,08	4,62
49W HO	0,260	0,144	0,581	4,22	15,10	5,36
54W HO	0,480	0,504	1,136	3,39	6,12	4,32
80W HO	0,525	0,580	1,170	3,05	2,45	3,87

3.4.2 Electronic controlgear qualification limits – CV_{\max}

The calculation of the normative maximum cathode voltage for ECG qualification on the specified resistor substitution network ($R_{\text{test}2}$, $R_{L10\min}$, $R_{L10\max}$, R_{L30} and R_{L60}) is done by transforming the informative maximum cathode voltage limit, CV'_{\max} for lamp-ECG systems into a cathode voltage limit for the substitution resistor networks, CV_{\max} . As in 3.3.2, the cathode heating characteristics (see 3.2.1) are used to determine the maximum cathode power, $P'_{\max0}$, with no lamp current,

$$P'_{\max0} = [CV'_{\max} / a2]^{(1/b2)}$$

This heating power is then applied to the specified substitution resistor $R_{\text{test}2}$ and the resulting maximum cathode voltage for the substitution resistor is calculated,

$$CV_{\max} = [R_{\text{test}2} \times P'_{\max0}]^{(1/2)}$$

This value is specified as normative for ECG qualification at $I_D = I_{D\min}$, I_{D30} and I_{D60} in the lamp datasheets. This normative CV_{\max} limit shall also apply to all ECG that, by design (e.g. step-dimming ECG), are required to be tested at other I_D levels. The substitution resistor network ($R_{\text{test}2}$, $R_{L10\min}$, $R_{L10\max}$, R_{L30} and R_{L60} or R_L) shall use the same lamp substitution resistor as employed in ECG qualification testing for SoS_{\min} or CV_{\min} specifications.

4 Example of calculation for 54W HO lamps

4.1 General

The example given in this clause is intended to illustrate the calculation methodology of this technical report. Parameter values for the 54W T5 HO lamps are selected from the best available data at the time of publication of this technical report. Future modifications to the IEC 60081 datasheets will not necessitate revision of this report clause. Further, this clause is not intended as informative or normative for 54W T5 HO lamps.

The calculation begins with the following input parameters (see Table 4).

Table 4 – Datasheet parameters

Parameter	Value
Cathode test current, I_{test}	0,480 A
Minimum dimming discharge current, $I_{D\min}$	0,050 A
Maximum dimming discharge current, $I_{D\text{trans}}$	0,380 A
Lamp operating current 30 %, I_{D30}	0,144 A
Cathode substitution resistor, $R_{\text{test}1}$	7,5 Ω
Cathode substitution resistor, $R_{\text{test}2}$	8,5 Ω
Cathode substitution resistor, $R_{\text{test}3}$	7,0 Ω
Sum of squares lead currents at I_{D30} , SoS_{30} for ECG qualification	0,282 A ²

4.2 Calculation of lamp and ECG systems – SoS'_{\min}

The auxiliary heat delivered to the cathode substitution resistor, R_{test1} , under conditions at $I_D = I_{D30}$ is

$$\begin{aligned} \text{Heat aux}_{30} &= \frac{1}{2} SoS_{30} \times R_{\text{test1}} - \frac{1}{4} I_{D30}^2 \times R_{\text{test1}} \\ &= \frac{1}{2} (0,282) (7,5) - \frac{1}{4} (0,144)^2 (7,5) = 1,019 \text{ W} \end{aligned}$$

The voltage that delivers the same auxiliary heat to a 54W T5 HO cathode is

$$\begin{aligned} CV'_{\min30} &= a2 [\text{Heat aux}_{30}]^{b2} \\ &= (2,475 \ 9) [1,019]^{0,695 \ 4} = 2,508 \text{ V} \end{aligned}$$

The current that delivers the same auxiliary heat to a 54W T5 HO cathode is

$$\begin{aligned} I'_{\min30} &= a1 [CV'_{\min30}]^{b1} \\ &= (0,271 \ 6) [2,508]^{0,437 \ 8} = 0,406 \text{ A} \end{aligned}$$

The minimum sum-of-squared lead currents, SoS'_{30} , at I_{D30} for the lamp-ECG system is then calculated as follows:

$$\begin{aligned} SoS'_{30} &= (I'_{\min30} + \frac{1}{2} I_{D30})^2 + (I'_{\min30} - \frac{1}{2} I_{D30})^2 = 2 I'_{\min30}{}^2 + \frac{1}{2} I_{D30}{}^2 \\ &= 2 (0,406)^2 + \frac{1}{2} (0,144)^2 = 0,340 \text{ A}^2 \end{aligned}$$

The coefficients of the informative SoS'_{\min} limit line are then calculated:

$$\begin{aligned} Y_1 &= [SoS'_{30} - \frac{1}{2} I_{Dtrans}^2] / [I_{Dtrans} - I_{D30}] \\ &= [0,340 - \frac{1}{2} (0,380)^2] / [0,380 - 0,144] = 1,136 \text{ A} \\ X_1 &= \frac{1}{2} I_{Dtrans}^2 + Y_1 \times I_{Dtrans} \\ &= \frac{1}{2} (0,380)^2 + 1,136 (0,380) = 0,504 \text{ A}^2 \end{aligned}$$

And the informative SoS'_{\min} limit line (see 3.2.1) is

$$\begin{aligned} SoS'_{\min} [I_{LH}^2 + I_{LL}^2] &= X_1 - Y_1 \times I_D \quad \text{for } I_{D30} \leq I_D < I_{Dtrans} \\ SoS'_{\min} &= 0,504 - 1,136 \times I_D \end{aligned}$$

4.3 Calculation of lamp and ECG systems – CV'_{\min}

The informative minimum cathode voltage line is calculated starting from the voltage that heats the cathode to $R_h/R_c \sim 4,3$

$$\begin{aligned} CV'_{\min10} &= [(R_h/R_c)/a3]^{(1/b3)} \\ &= [4,30 / 2,288 \ 3]^{(1/0,560 \ 8)} = 3,083 \text{ V} \end{aligned}$$

The coefficients of the informative minimum cathode voltage limit line are then calculated:

$$\begin{aligned} Y_3 &= [CV'_{\min10} - CV'_{\min30}] / [I_{D30} - I_{Dmin}] \\ &= [3,083 - 2,508] / [0,144 - 0,050] = 6,12 \ \Omega \\ X_3 &= CV'_{\min30} + Y_3 \times I_{D30} \\ &= 2,508 + 6,12 \times 0,144 = 3,39 \text{ V} \end{aligned}$$

And the informative minimum cathode voltage limit line (see 3.3.1) is

$$\begin{aligned} CV'_{\min} &= X_3 - Y_3 \times I_D && \text{for } I_{Dmin} \leq I_D < I_{D30} \\ CV'_{\min} &= 3,39 - 6,12 I_D \end{aligned}$$

4.4 Calculation of ECG qualification limits – CV_{\min}

Steps in the calculation of the normative minimum cathode voltage for ECG qualification (see 3.3.2) are as follows. The minimum cathode power with no lamp current ($I_D = 0$) is

$$\begin{aligned} P'_{\min 0} &= [X'_3 / a2]^{(1/b2)} \\ &= [3,39 / 2,475\ 9]^{(1/0,695\ 4)} = 1,57\ \text{W} \end{aligned}$$

This heating power is then applied to the specified substitution resistor $R_{\text{test}3}$ and the resulting resistor voltage is calculated:

$$\begin{aligned} V_{\min 0} &= [R_{\text{test}3} \times P'_{\min 0}]^{(1/2)} \\ &= [7,0 \times 1,57]^{(1/2)} = 3,316\ \text{V} \end{aligned}$$

The invariant delivered auxiliary cathode heat at $I_D = I_{D30}$ is then used to calculate a voltage for the substitution resistor $R_{\text{test}3}$ at I_{D30} .

$$\begin{aligned} V_{\min 30} &= [R_{\text{test}3} \times \text{Heat aux}_{30}]^{(1/2)} \\ &= [7,0 \times 1,019]^{(1/2)} = 2,670\ \text{V} \end{aligned}$$

The transformed voltage limit equation is now determined:

$$CV_{\min} = X_3 - Y_3 \times I_D$$

With the coefficients given by

$$\begin{aligned} X_3 &= V_{\min 0} \\ &= 3,316\ \text{V} \\ Y_3 &= [V_{\min 0} - V_{\min 30}] / I_{D30} \\ &= [3,316 - 2,670] / (0,144) = 4,48\ \Omega \end{aligned}$$

The minimum cathode voltage for the substitution resistor at the minimum dimming discharge current is given by

$$\begin{aligned} CV_{\min} &= X_3 - Y_3 \times I_{D\min} \\ &= 3,316 - 4,48 \times 0,050 = 3,09\ \text{V} \end{aligned}$$

4.5 Calculation of lamp and ECG systems – CV'_{\max}

The maximum cathode heating limit for the informative lamp-ECG system is determined by calculating the cathode voltage required for $R_h/R_c = 5,2$ (see 3.4.1)

$$\begin{aligned} CV'_{\max} &= [(R_h/R_c) / a3]^{(1/b3)} \\ &= [5,2 / 2,288\ 3]^{(1/0,5608)} = 4,321\ \text{V} \end{aligned}$$

4.6 Calculation of ECG qualification limits – CV_{\max}

Steps in the calculation of the normative maximum cathode voltage for ECG qualification (see 3.4.2) are as follows. The cathode heating characteristics (see 3.2.1) are used to determine the maximum cathode power with no lamp current ($I_D = 0$),

$$\begin{aligned} P'_{\max 0} &= [CV'_{\max} / a2]^{(1/b2)} \\ &= [4,321 / 2,475\ 9]^{(1/0,6954)} = 2,23\ \text{W} \end{aligned}$$

This heating power is then applied to the specified substitution resistor R_{test2} and the resulting maximum cathode voltage for the substitution resistor is calculated:

$$CV_{\text{max}} = [R_{\text{test2}} \times P'_{\text{max0}}]^{(1/2)} \\ = [8,5 \times 2,23]^{(1/2)} = 4,35 \text{ V}$$

5 Glossary of symbols

Symbol	Explanation
a_1	Cathode fitted power law parameter: scaling for current vs voltage
a_2	Cathode fitted power law parameter: scaling for voltage vs power
a_3	Cathode fitted power law parameter: scaling for R_h/R_c vs voltage
b_1	Cathode fitted power law parameter: exponent for current vs voltage
b_2	Cathode fitted power law parameter: exponent for voltage vs power
b_3	Cathode fitted power law parameter: exponent for R_h/R_c vs voltage
CV	cathode voltage model
CV'	root mean square voltage (r.m.s.) applied across the cathode
CV'_{max}	maximum voltage across a cathode
CV'_{min}	limit line of minimum cathode voltage
CV'_{min10}	minimum voltage across a cathode at $I_D = I_{D\text{min}}$
CV'_{min30}	minimum voltage across a cathode at $I_D = I_{D30}$
$CV_{D\text{min}}$	minimum voltage ³ across the substitution resistor at $I_D = I_{D\text{min}}$
CV_{max}	maximum voltage ³ across the cathode substitution resistor
CV_{min}	limit line of minimum cathode substitution resistor voltage
ECG	electronic controlgear
$Heat\ aux_{30}$	auxiliary heat delivered to the cathode maintained invariant at $I_D = I_{D30}$ in the transformation: ECG-lamps → ECG-resistors
I	cathode characterization test current
I'_{min30}	cathode current that delivers auxiliary heat equal to $Heat\ aux_{30}$
I_D	discharge current
I_{D30}	discharge current ³ at approximately 30 % of I_{test}
I_{D60}	discharge current ³ at approximately 60 % of I_{test}
$I_{D\text{min}}$	minimum lamp current ³ for dimming specified in the lamp standard
$I_{D\text{trans}}$	lamp current transition ³ between normal range (no heating necessary) and dimming range (auxiliary heating required)
I_{LH}	I lead high = highest current through either lead-in wire
$I_{LH\text{max}}$	maximum allowed current ³ in any lead
I_{LL}	I lead low = lowest current through either lead-in wire
I_{test}	cathode test current ³

³ Value specified in relevant lamp datasheet.

Symbol	Explanation
P	cathode characterization test power
$P'_{\max 0}$	maximum cathode power with no lamp current
$P'_{\min 0}$	minimum cathode power with no lamp current
R_c	cathode “cold” resistance at 25 °C
R_h	cathode “hot” resistance during operation
R_L	lamp discharge substitution resistance
$R_{L10\max}$	high-impedance lamp discharge substitution resistance ³ at $I_D = I_{D\min}$
$R_{L10\min}$	low-impedance lamp discharge substitution resistance ³ at $I_D = I_{D\min}$
R_{L30}	lamp discharge substitution resistance ³ at $I_D = I_{D30}$
R_{L60}	lamp discharge substitution resistance ³ at $I_D = I_{D60}$
$R_{L\max}$	lamp discharge substitution resistance interpolated between $R_{L10\max}$ and R_{L30}
$R_{L\min}$	lamp discharge substitution resistance interpolated between $R_{L10\min}$ and R_{L30}
R_{LW}	maximum lead wire resistance ⁴
$R_{\text{test}1}$	cathode substitution resistance ³ for ECG qualification - SoS_{\min} tests
$R_{\text{test}2}$	cathode substitution resistance ³ for ECG qualification - CV_{\max} tests
$R_{\text{test}3}$	cathode substitution resistance ³ for ECG qualification - CV_{\min} tests
SoS	sum of squared currents model for cathode substitution resistors
SoS'	sum of squared leadwire currents model for cathodes
SoS' ₃₀	minimum sum of squared leadwire currents for cathodes at $I_D = I_{D30}$
SoS' _{min}	limit line of minimum sum of squared leadwire currents for cathodes: $SoS'_{\min} = X'_1 - Y'_1 \times I_D$
SoS' _{tgt}	target line of sum of squared leadwire currents for ECG design guidance
SoS ₃₀	minimum sum of squared currents for cathode substitution resistors at $I_D = I_{D30}$
SoS _{min}	limit line of minimum sum of squared currents for cathode substitution resistors: $SoS_{\min} = X_1 - Y_1 \times I_D$
V	cathode characterization test voltage
$V_{\min 0}$	voltage across cathode substitution resistor at $P = P'_{\min 0}$
$V_{\min 30}$	voltage across cathode substitution resistor at $P = Heat\ aux_{30}$
X'_1	SoS' _{min} limit line coefficient: intercept
X'_3	CV _{min} limit line coefficient: intercept
X_1	SoS _{min} limit line coefficient: intercept ⁵
X_3	CV _{min} limit line coefficient: intercept

⁴ Value specified in relevant lamp standard.

⁵ Value specified in relevant lamp datasheet.

Symbol	Explanation
Y_1	SoS'_{min} limit line coefficient: slope
Y_3	CV'_{min} limit line coefficient: slope
Y_1	SoS_{min} limit line coefficient: slope ⁵
Y_3	CV_{min} limit line coefficient: slope

Bibliography

IEC 60081, *Double-capped fluorescent lamps – Performance specifications*

IEC 60929, *AC and/or DC-supplied electronic control gear for tubular fluorescent lamps – Performance requirements*

British Standards Institution (BSI)

BSI is the national body responsible for preparing British Standards and other standards-related publications, information and services.

BSI is incorporated by Royal Charter. British Standards and other standardization products are published by BSI Standards Limited.

About us

We bring together business, industry, government, consumers, innovators and others to shape their combined experience and expertise into standards-based solutions.

The knowledge embodied in our standards has been carefully assembled in a dependable format and refined through our open consultation process. Organizations of all sizes and across all sectors choose standards to help them achieve their goals.

Information on standards

We can provide you with the knowledge that your organization needs to succeed. Find out more about British Standards by visiting our website at bsigroup.com/standards or contacting our Customer Services team or Knowledge Centre.

Buying standards

You can buy and download PDF versions of BSI publications, including British and adopted European and international standards, through our website at bsigroup.com/shop, where hard copies can also be purchased.

If you need international and foreign standards from other Standards Development Organizations, hard copies can be ordered from our Customer Services team.

Subscriptions

Our range of subscription services are designed to make using standards easier for you. For further information on our subscription products go to bsigroup.com/subscriptions.

With **British Standards Online (BSOL)** you'll have instant access to over 55,000 British and adopted European and international standards from your desktop. It's available 24/7 and is refreshed daily so you'll always be up to date.

You can keep in touch with standards developments and receive substantial discounts on the purchase price of standards, both in single copy and subscription format, by becoming a **BSI Subscribing Member**.

PLUS is an updating service exclusive to BSI Subscribing Members. You will automatically receive the latest hard copy of your standards when they're revised or replaced.

To find out more about becoming a BSI Subscribing Member and the benefits of membership, please visit bsigroup.com/shop.

With a **Multi-User Network Licence (MUNL)** you are able to host standards publications on your intranet. Licences can cover as few or as many users as you wish. With updates supplied as soon as they're available, you can be sure your documentation is current. For further information, email bsmusales@bsigroup.com.

BSI Group Headquarters

389 Chiswick High Road London W4 4AL UK

Revisions

Our British Standards and other publications are updated by amendment or revision.

We continually improve the quality of our products and services to benefit your business. If you find an inaccuracy or ambiguity within a British Standard or other BSI publication please inform the Knowledge Centre.

Copyright

All the data, software and documentation set out in all British Standards and other BSI publications are the property of and copyrighted by BSI, or some person or entity that owns copyright in the information used (such as the international standardization bodies) and has formally licensed such information to BSI for commercial publication and use. Except as permitted under the Copyright, Designs and Patents Act 1988 no extract may be reproduced, stored in a retrieval system or transmitted in any form or by any means – electronic, photocopying, recording or otherwise – without prior written permission from BSI. Details and advice can be obtained from the Copyright & Licensing Department.

Useful Contacts:

Customer Services

Tel: +44 845 086 9001

Email (orders): orders@bsigroup.com

Email (enquiries): cservices@bsigroup.com

Subscriptions

Tel: +44 845 086 9001

Email: subscriptions@bsigroup.com

Knowledge Centre

Tel: +44 20 8996 7004

Email: knowledgecentre@bsigroup.com

Copyright & Licensing

Tel: +44 20 8996 7070

Email: copyright@bsigroup.com



...making excellence a habit.™