



BSI Standards Publication

Secondary lithium-ion cells for the propulsion of electric road vehicles

Part 4: Candidate alternative test methods for
the internal short circuit test of IEC 62660-3

National foreword

This Published Document is the UK implementation of IEC/TR 62660-4:2017.

The UK participation in its preparation was entrusted to Technical Committee PEL/21, Secondary cells and batteries.

A list of organizations represented on this committee can be obtained on request to its secretary.

This publication does not purport to include all the necessary provisions of a contract. Users are responsible for its correct application.

© The British Standards Institution 2017.

Published by BSI Standards Limited 2017

ISBN 978 0 580 95495 5

ICS 29.220.20

Compliance with a British Standard cannot confer immunity from legal obligations.

This Published Document was published under the authority of the Standards Policy and Strategy Committee on 31 March 2017.

Amendments/corrigenda issued since publication

Date	Text affected
-------------	----------------------



TECHNICAL REPORT



Secondary lithium-ion cells for the propulsion of electric road vehicles – Part 4: Candidate alternative test methods for the internal short circuit test of IEC 62660-3

INTERNATIONAL
ELECTROTECHNICAL
COMMISSION

ICS 29.220.20

ISBN 978-2-8322-3715-1

Warning! Make sure that you obtained this publication from an authorized distributor.

CONTENTS

FOREWORD.....	4
INTRODUCTION.....	6
1 Scope.....	7
2 Normative references	7
3 Terms and definitions	7
4 General provisions for alternative test	7
5 Alternative test method.....	8
5.1 Alternative test method description	8
5.1.1 General	8
5.1.2 Test preparation and test set-up	8
5.1.3 Test execution.....	10
5.1.4 Acceptance criteria	11
Annex A (informative) Test data.....	12
A.1 General.....	12
A.2 Test data	12
A.2.1 Test results	12
A.2.2 Data of each test	18
Figure 1 – Example of test setup 1.....	9
Figure 2 – Example of test setup 2.....	9
Figure 3 – Example of ceramic nail with Ni tip.....	10
Figure 4 – Example of ceramic nail with Ni tip test	10
Figure A.1 – Voltage and temperature of test 1-1.....	18
Figure A.2 – Voltage and temperature of test 1-2.....	18
Figure A.3 – Voltage and temperature of test 1-3.....	19
Figure A.4 – Voltage and temperature of test 2-1.....	19
Figure A.5 – Voltage and temperature of test 2-2.....	20
Figure A.6 – Voltage and temperature of test 2-3.....	20
Figure A.7 – Voltage and temperature of test 3-1.....	21
Figure A.8 – Voltage and temperature of test 3-2.....	21
Figure A.9 – $\varnothing 3$ mm ceramic nail with Ni tip	22
Figure A.10 – Voltage and temperature of test 4	22
Figure A.11 – Voltage and temperature of test 5-1	23
Figure A.12 – Voltage and temperature of test 5-2	23
Figure A.13 – Voltage data of tests 6	24
Figure A.14 – Voltage data of tests 7	24
Figure A.15 – Voltage data of tests 8	25
Figure A.16 – Voltage data of tests 9	25
Figure A.17 – Voltage data of tests 10-1	26
Figure A.18 – Voltage data of tests 10-2	26
Figure A.19 – Voltage data of test 11-1.....	27
Figure A.20 – Voltage data of test 11-2.....	27

Figure A.21 – Voltage data of test 12-1 28

Figure A.22 – Voltage data of test 12-2 28

Figure A.23 – Voltage data of test 12-3 28

Figure A.24 – Voltage data of test 12-4 29

Figure A.25 – Voltage data of test 12-5 29

Figure A.26 – Voltage data of test 12-6 29

Figure A.27 – Voltage data of test 12-7 30

Figure A.28 – Voltage data of test 13 30

Figure A.29 – Voltage data of test 14-1 31

Figure A.30 – Voltage data of test 14-2 31

Figure A.31 – Voltage data of test 14-3 31

Figure A.32 – Voltage data of test 14-4 32

Figure A.33 – Voltage data of test 14-5 32

Figure A.34 – Voltage data of tests 15 33

Figure A.35 – Voltage data of tests 16 34

Table 1 – Recommended test specifications 8

Table A.1 – Internal short circuit test results 13

INTERNATIONAL ELECTROTECHNICAL COMMISSION

SECONDARY LITHIUM-ION CELLS FOR THE PROPULSION OF ELECTRIC ROAD VEHICLES –

Part 4: Candidate alternative test methods for the internal short circuit test of IEC 62660-3

FOREWORD

- 1) The International Electrotechnical Commission (IEC) is a worldwide organization for standardization comprising all national electrotechnical committees (IEC National Committees). The object of IEC is to promote international co-operation on all questions concerning standardization in the electrical and electronic fields. To this end and in addition to other activities, IEC publishes International Standards, Technical Specifications, Technical Reports, Publicly Available Specifications (PAS) and Guides (hereafter referred to as "IEC Publication(s)"). Their preparation is entrusted to technical committees; any IEC National Committee interested in the subject dealt with may participate in this preparatory work. International, governmental and non-governmental organizations liaising with the IEC also participate in this preparation. IEC collaborates closely with the International Organization for Standardization (ISO) in accordance with conditions determined by agreement between the two organizations.
- 2) The formal decisions or agreements of IEC on technical matters express, as nearly as possible, an international consensus of opinion on the relevant subjects since each technical committee has representation from all interested IEC National Committees.
- 3) IEC Publications have the form of recommendations for international use and are accepted by IEC National Committees in that sense. While all reasonable efforts are made to ensure that the technical content of IEC Publications is accurate, IEC cannot be held responsible for the way in which they are used or for any misinterpretation by any end user.
- 4) In order to promote international uniformity, IEC National Committees undertake to apply IEC Publications transparently to the maximum extent possible in their national and regional publications. Any divergence between any IEC Publication and the corresponding national or regional publication shall be clearly indicated in the latter.
- 5) IEC itself does not provide any attestation of conformity. Independent certification bodies provide conformity assessment services and, in some areas, access to IEC marks of conformity. IEC is not responsible for any services carried out by independent certification bodies.
- 6) All users should ensure that they have the latest edition of this publication.
- 7) No liability shall attach to IEC or its directors, employees, servants or agents including individual experts and members of its technical committees and IEC National Committees for any personal injury, property damage or other damage of any nature whatsoever, whether direct or indirect, or for costs (including legal fees) and expenses arising out of the publication, use of, or reliance upon, this IEC Publication or any other IEC Publications.
- 8) Attention is drawn to the Normative references cited in this publication. Use of the referenced publications is indispensable for the correct application of this publication.
- 9) Attention is drawn to the possibility that some of the elements of this IEC Publication may be the subject of patent rights. IEC shall not be held responsible for identifying any or all such patent rights.

The main task of IEC technical committees is to prepare International Standards. However, a technical committee may propose the publication of a Technical Report when it has collected data of a different kind from that which is normally published as an International Standard, for example "state of the art".

IEC TR 62660-4, which is a Technical Report, has been prepared by IEC technical committee 21: Secondary cells and batteries.

The text of this Technical Report is based on the following documents:

Enquiry draft	Report on voting
21/891/DTR	21/899/RVC

Full information on the voting for the approval of this Technical Report can be found in the report on voting indicated in the above table.

This document has been drafted in accordance with the ISO/IEC Directives, Part 2.

A list of all parts in the IEC 62660 series, published under the general title *Secondary lithium-ion cells for the propulsion of electric road vehicles*, can be found on the IEC website.

The committee has decided that the contents of this document will remain unchanged until the stability date indicated on the IEC website under "<http://webstore.iec.ch>" in the data related to the specific document. At this date, the document will be

- reconfirmed,
- withdrawn,
- replaced by a revised edition, or
- amended.

A bilingual version of this publication may be issued at a later date.

IMPORTANT – The 'colour inside' logo on the cover page of this publication indicates that it contains colours which are considered to be useful for the correct understanding of its contents. Users should therefore print this document using a colour printer.

INTRODUCTION

IEC 62660-3 provides the test procedures and acceptance criteria for safety performance of secondary lithium-ion cells and cell blocks used for propulsion of electric vehicles (EV) including battery electric vehicles (BEV) and hybrid electric vehicles (HEV). IEC 62660-3 specifies the internal short circuit test to simulate an internal short circuit of a cell caused by the contamination of conductive particle, based on IEC 62619. Because the test method based on IEC 62619 requires opening of the cell and care to be taken, the industry needs alternative test methods that could also be applied under certain conditions. This document provides candidates of alternative test procedures.

NOTE This test is to be conducted in a facility suitable to contain the potential for hazardous reactions up to and including an explosion and with staff trained to manage the risks.

SECONDARY LITHIUM-ION CELLS FOR THE PROPULSION OF ELECTRIC ROAD VEHICLES –

Part 4: Candidate alternative test methods for the internal short circuit test of IEC 62660-3

1 Scope

This Part of IEC 62660 provides the test data on the candidate alternative test methods for the internal short circuit test according to 6.4.4.2.2 of IEC 62660-3:2016. The internal short circuit test in this document is intended to simulate an internal short circuit of a cell caused by the contamination of conductive particle, and to verify the safety performance of the cell under such conditions.

This document is applicable to the secondary lithium-ion cells and cell blocks used for propulsion of electric vehicles (EV) including battery electric vehicles (BEV) and hybrid electric vehicles (HEV).

NOTE This document does not cover cylindrical cells.

2 Normative references

The following documents are referred to in the text in such a way that some or all of their content constitutes requirements of this document. For dated references, only the edition cited applies. For undated references, the latest edition of the referenced document (including any amendments) applies.

IEC 62619:2017, *Secondary cells and batteries containing alkaline or other non-acid electrolytes – Safety requirements for secondary lithium cells and batteries, for use in industrial applications*

IEC 62660-3:2016, *Secondary lithium-ion cells for the propulsion of electric road vehicles – Part 3: Safety requirements*

3 Terms and definitions

For the purposes of this document, the terms and definitions given in IEC 62660-3 apply.

ISO and IEC maintain terminological databases for use in standardization at the following addresses:

- IEC Electropedia: available at <http://www.electropedia.org/>
- ISO Online browsing platform: available at <http://www.iso.org/obp>.

4 General provisions for alternative test

The internal short circuit test is specified in 6.4.4.2.1 of IEC 62660-3:2016. The other test methods to simulate the internal short circuit of cell caused by the contamination of conductive particle may be selected if the following criteria are satisfied, and agreed between the customer and the supplier:

- a) The case deformation shall not affect the short circuit event of cell thermally or electrically. The energy shall not be dispersed by any short circuit other than the interelectrode short circuit.
- b) One layer internal short circuit between positive and negative electrode shall be simulated (target).
- c) Approximately the same short circuited area as that of 7.3.2 b) of IEC 62619:2017 shall be simulated.
- d) The short circuited locations in the cell shall be the same as described in 6.4.4.2.1 of IEC 62660-3:2016.
- e) The test shall be repeatable (see Table 1 of IEC 62619:2017).

The detailed test conditions and parameters of an alternative test shall be adjusted before the test according to the agreement between the customer and the cell manufacturer, so that the above criteria can be satisfied. The test result shall be evaluated by the disassembly of the cell, X-ray observation, etc.

If the test result shows more than one layer internal short circuit, or larger short circuited area, the test may be deemed as valid alternative test, provided that the acceptance criteria in 6.4.4.3 of IEC 62660-3:2016 are satisfied. The failure in an alternative test does not mean the failure in the test according to 6.4.4.2.1 of IEC 62660-3:2016, because the test condition of the alternative test may be more severe than the prescribed criteria.

NOTE In case the internal short circuit cannot be simulated, the test is invalid and the test data are reported.

5 Alternative test method

5.1 Alternative test method description

5.1.1 General

This subclause describes the test method of the indentation induced internal short circuit test as a candidate of alternative test methods in Clause 4. Table 1 provides the recommended test specifications of the test.

Table 1 – Recommended test specifications

Item	Recommendation
Test temperature (temperature of the test bench and cell)	25 °C ± 5 °C
State of charge (SOC) of the cell	Maximum SOC specified by the cell manufacturer
Press speed	0,1 mm/s or less
Press speed accuracy	± 0,01 mm/s
Position stability after pressurizing	± 0,02 mm
Maximum pressurizing capability	1 000 N or more
Pressure measuring method	Directly measured with a load cell
Pressure measuring period	5 ms or less
Temperature measuring period	1 s or less
Voltage measuring period	5 ms or less
Time to stop the indenter after voltage drop is detected	100 ms or less

5.1.2 Test preparation and test set-up

5.1.2.1 Cell preparation

For flat or pouch cell, no preparation is needed.

For prismatic cell with hard casing, casing could be thinned or removed by an appropriate method recommended by the cell manufacturer. Thinning or removal of casing should be conducted before the charging of cell and SOC adjustment. This operation should be conducted taking all the safety measures needed.

5.1.2.2 Test setup

The cell should be held in a manner not to move during the test. The cell should be electrically isolated from test bench.

A flat or pouch cell requires a fixation device. Figure 1 and Figure 2 show examples of the fixation device.

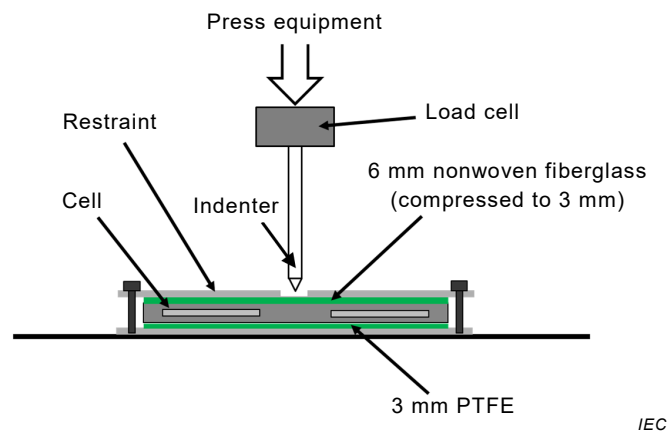

IEC

Figure 1 – Example of test setup 1

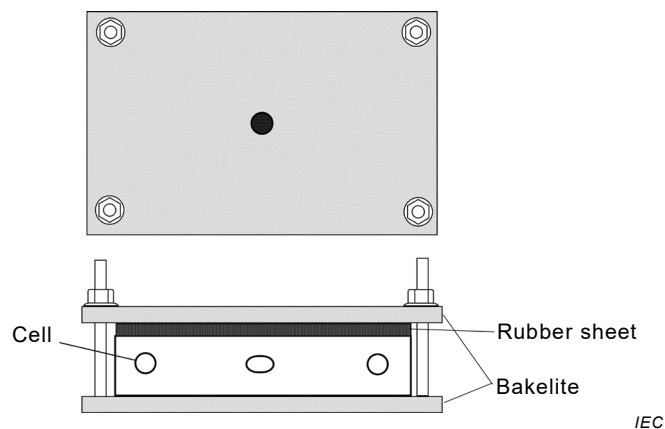

IEC

Figure 2 – Example of test setup 2

5.1.2.3 Indenter device

5.1.2.3.1 General

Two types of indenter device, as defined in 5.1.2.3.2 and 5.1.2.3.3 are proposed in this alternative test method.

5.1.2.3.2 Type 1: 3 mm ceramic nail

Type 1 indenter is a ceramic nail having a diameter of $3 \text{ mm} \pm 0,2 \text{ mm}$. The angle of the nail tip should be $45^\circ \pm 3^\circ$. Figure 1 shows an example of the ceramic nail's orientation to the cell electrode layers during the press.

5.1.2.3.3 Type 2: 1 mm ceramic nail with Ni tip

Type 2 indenter is a ceramic nail having a diameter of $1\text{ mm} \pm 0,1\text{ mm}$ with a nickel (Ni) tip of $0,35\text{ mm}$ in height. The angle of the Ni nail tip should be between 28° and 45° . See Figure 3 and Figure 4.

A ceramic nail with a Ni tip is suitable for a prismatic cell with a hard casing and a flat or pouch cell.

The test using the Type 1 indenter is not applicable to the cells of which the casing is used as a part of the electrodes. If the casing is removed, this test may be applicable.

Dimensions in millimetres

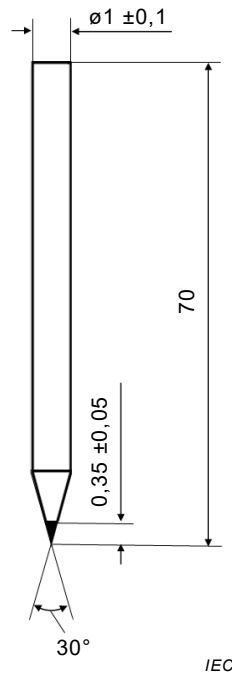

Figure 3 – Example of ceramic nail with Ni tip

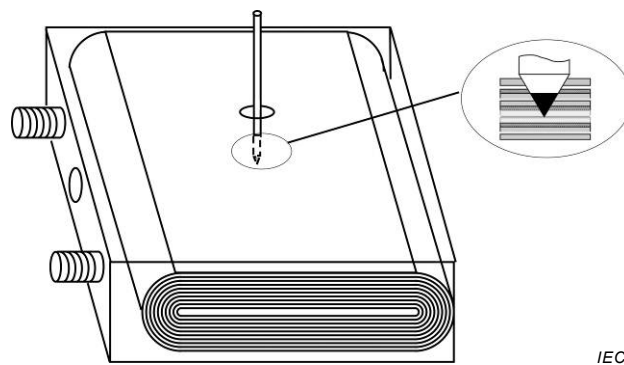

Figure 4 – Example of ceramic nail with Ni tip test

5.1.3 Test execution

The test should be conducted as follows:

- a) Prepare the cell in accordance with 5.1.2.1.

- b) Adjust the SOC of the cell in accordance with 5.3 of IEC 62660-3:2016, at the maximum SOC specified by the cell manufacturer.
- c) Fix the cell to the test setup in accordance with 5.1.2.2. The indenter device should be selected according to 5.1.2.3, based on the agreement between the customer and the supplier. The indenter should be placed perpendicular to the electrode layers of the cell. The cell or the indenter should move along this perpendicular axis. The indentation location should be the same as IEC 62660-3:2016.
- d) Press the indenter to the cell, or press the cell up to the indenter, with a constant velocity of less than 0,1 mm/s. Displacement of the indenter should be stopped when a voltage drop of at least 5 mV is detected. It is acceptable to use a voltage drop of less than 5 mV if a high accuracy voltage meter is used and the actual short location can be confirmed with an inspection of the internal short location after the test. The accuracy of the voltage meter should be reported. If the voltage drop of at least 5 mV is not detected until the indenter is depressed to half the thickness of a cell, the test should be stopped and considered as invalid, and the test should be conducted once again.
- e) After the indentation stops, the indenter should remain in place until the end of the observation period. During the test, the cell voltage, the force of the press, the displacement of the press and the temperature of the cell should be recorded. The cell temperature should be measured on the surface of the cell, at a distance of less than 25 mm from the centre of the indentation. Sampling time for voltage and pressure recording should be 5 ms or less. Sampling time for other parameters recording should be 1 s or less.

5.1.4 Acceptance criteria

During the test and within 1 h of observation, the cell should exhibit no evidence of fire or explosion.

Annex A (informative)

Test data

A.1 General

This annex provides information on the result of tests conducted according to Clause 5, and of relevant comparison tests.

The reproducibility of each test result is confirmed on several cell designs. Further test data need to be evaluated with cells that failed the test in 6.4.4.2.1 of IEC 62660-3:2016, etc.

A.2 Test data

A.2.1 Test results

Table A.1 shows the result of internal short circuit tests on several types of cells, using the indenters in 5.1.2.3, and other types of indenters for comparison. The forced internal short circuit (FISC) test in 6.4.4.2.1 of IEC 62660-3:2016 is also conducted as comparison test.

All cells in Table A.1 exhibited no evidence of fire or explosion, and met the acceptance criteria in 5.1.4.

In most of the tests except FISC test, the number of short circuited layers is larger than one layer, and also varies among the same cells.

Further data of each test are shown in A.2.2.

Table A.1 – Internal short circuit test results

Test No.	Indenter type or FISC	Cell	Chemistry or Capacity or Application (HEV/PHEV/BEV)	Type of cell and case thickness	Press speed mm/s	Target voltage drop for indenter stop mV	Test result					
							Voltage drop at indenter stop mV	Temp. rise °C	Number of short circuited layers	Pass-Fail	Optional info.	Fig. No.
1-1	FISC ^d	A	HC ^a /MNC ^b , 5 Ah, HEV	prismatic	0,1	5	5	< 1	+e:2, -f:2	Pass		A.1
1-2					0,1	5	3	4	+i:1, -j:2	Pass		A.2
1-3					0,1	5	12	< 1	+i:1, -j:2	Pass		A.3
2-1	Type 2		SC ^c /MNC, 5 Ah, HEV	prismatic	0,1	5	7	23	+k:4, -l:4	Pass		A.4
2-2	Type 2	B			0,1	5	6	35	+m:5, -n:5	Pass		A.5
2-3					0,1	2	2	2	+o:3, -p:3	Pass		A.6
3-1	Ø1 all ceramic nail	A	HC/MNC, 5 Ah, HEV	prismatic	1,0	25	20	20	+q:7, -r:6	Pass		A.7
3-2	Type 2				1,0	25	30	19	+s:8, -t:8	Pass		A.8
4	Ø3 ceramic nail + Ni tip				0,1	2	2,4	0,9	+u:2, -v:3	Pass		A.10
5-1			0,1	5	13,4	7,5	+w:3, -x:4	Pass		A.11		
5-2			0,1	20	21,4	21,4	+y:8, -z:8	Pass		A.12		

Test No.	Indenter type or FISC	Cell	Chemistry or Capacity or Application (HEV/PHEV/BEV)	Type of cell and case thickness	Press speed mm/s	Target voltage drop for indenter stop mV	Test result					
							Voltage drop at indenter stop mV	Temp. rise °C	Number of short circuited layers	Pass-Fail	Optional info.	Fig. No.
6-1	Type 2	C	BEV	pouch	0,01	2	2	49	+4, -4	Pass	A.13	
6-2							3	0,3	+2, -2	Pass		
6-3							12	0,1	+1, -2	Pass		
6-4							6	47	+1, -1	Pass		
6-5							3	52	+3, -3	Pass		
7-1	Type 2	D	HEV	pouch	0,01	2	10		+3, -3	Pass	A.14	
7-2							4		+3, -4	Pass		
7-3							6	34	+3, -4	Pass		
7-4							10	43	+3, -4	Pass		
7-5							6	31	+2, -3	Pass		
8-1	ø3 all ceramic nail + 20° angle	C	BEV	pouch	0,01	2	1	47	+5, -5	Pass	A.15	
8-2							1	53	+5, -6	Pass		
8-3							1	41	+4, -4	Pass		
8-4							2	32	+4, -5	Pass		
8-5							1	31	+3, -3	Pass		

Test No.	Indenter type or FISC	Cell	Chemistry or Capacity or Application (HEV/PHEV/BEV)	Type of cell and case thickness	Press speed mm/s	Target voltage drop for indenter stop mV	Test result					
							Voltage drop at indenter stop mV	Temp. rise °C	Number of short circuited layers	Pass-Fail	Optional info.	Fig. No.
9-1	ø3 all ceramic nail + 20° angle	D	HEV	pouch	0,01	2	5	26	+2, -2	Pass		A.16
9-2							7	36	+2, -3	Pass		
9-3							6	31	+2, -3	Pass		
9-4	Type 1						5	30	+2, -3	Pass		
9-5	Type 1						9	71	+3, -3	Pass		
10-1	FISC	C	BEV	pouch	0,01	2	2	< 1	+1, -1	Pass		A.17
10-2	FISC	D	HEV	pouch	0,01	2	2	< 1	+1, -1	Pass		A.18
11-1	FISC	E	graphite/MNC 21,5Ah, PHEV ^g	prismatic 0,7 mm	0,01	2	3,1	-	+0, -1	Pass	no smoke	A.19
11-2	FISC	F	graphite/NCA ^h 5 Ah, HEV	prismatic 0,5 mm	0,01	2	1,9	-	+0, -1	Pass	no smoke	A.20
12-1	ø1 ceramic nail + Ni tip (45°, 1 mm)	E	graphite/MNC 21,5Ah, PHEV	prismatic 0,7 mm	0,01	2	7,4	-	+2, -2	Pass	no smoke	A.21
12-2							8,2	-	+2, -2	Pass	no smoke	A.22
12-3	Type 2 (30°)				0,01	2	9,6	-	+2, -2	Pass	no smoke	A.23

Test No.	Indenter type or FISC	Cell	Chemistry or Capacity or Application (HEV/PHEV/BEV)	Type of cell and case thickness	Press speed mm/s	Target voltage drop for indenter stop mV	Test result					
							Voltage drop at indenter stop mV	Temp. rise °C	Number of short circuited layers	Pass-Fail	Optional info.	Fig. No.
12-4	Ø3 ceramic nail + Ni tip (30°, 1 mm)	E	graphite/MNC 21,5Ah, PHEV	prismatic 0,7 mm	0,01	2	2,1	-	+;1, -;2	Pass	no smoke	A.24
12-5	Ø3 ceramic nail + Ni tip (45°, 1 mm)				0,1	2	2 362	-		Pass	smoke	A.25
12-6	Ø3 ceramic nail + Ni tip (45°, 1 mm)				0,001	2	8,5	-	+;1, -;2	Pass	no smoke	A.26
12-7	Ø3 ceramic nail + Ni tip (60°, 1 mm)				0,01	2	2 391	-		Pass	smoke	A.27
13	Ø3 ceramic nail + Ni tip (30°, 1 mm)	F	graphite/NCA 5 Ah, HEV	prismatic 0,5 mm	0,01	2	52	-	+;1, -;2	Pass	no smoke	A.28
14-1	Ø3 ceramic nail + Ni tip (45°, 1 mm)	G	graphite/MNC and LMO 60 Ah, PHEV	prismatic 0,85 mm	0,01	2	1 364	-	+;0, -;0	Fail	fire	A.29
14-2	Ø3 ceramic nail + Ni tip (45°, 1 mm)				0,01	2	1 455	-	+;0, -;0	Fail	fire	A.30
14-3	Type 2 (30°)			prismatic 0,05 mm	0,01	2	9,0	-	+;0, -;0	Pass	no smoke	A.31
14-4				prismatic 0 mm	0,01	2	2,0	-	+;7, -;8	Pass	no smoke	A.32
14-5				prismatic 0,05 mm	0,1	2	2,0	-	+;4, -;4	Pass	no smoke	A.33

Test No.	Indenter type or FISC	Cell	Chemistry or Capacity or Application (HEV/PHEV/BEV)	Type of cell and case thickness	Press speed mm/s	Target voltage drop for indenter stop mV	Test result					
							Voltage drop at indenter stop mV	Temp. rise °C	Number of short circuited layers	Pass-Fail	Optional info.	Fig. No.
15-1	Type 1	H	graphite/MNC 37 Ah, PHEV	pouch	0,01	5	2,0	26,4	+;12, -;12	Pass	no smoke	A.34a
15-2					0,01	5	5,0	13,4	+;8, -;8	Pass	no smoke	A.34b
15-3					0,01	5	3,0	36,5	+;4, -;4	Pass	no smoke	A.34c
15-4					0,01	5	5,0	52,8	+;9, -;9	Pass	no smoke	A.34d
15-5					0,01	5	5,0	25,0	+;6, -;6	Pass	no smoke	A.34e
16-1	Type 2				0,01	5	4,0	27,7	+;9, -;9	Pass	no smoke	A.35a
16-2					0,01	5	5,0	36,3	+;5, -;5	Pass	no smoke	A.35b
16-3					0,01	5	2,0	24,8	+;4, -;4	Pass	no smoke	A.35c
16-4					0,01	5	4,0	23,8	+;7, -;7	Pass	no smoke	A.35d
16-5					0,01	5	3,0	26,6	+;6, -;6	Pass	no smoke	A.35e
a	Hard carbon											
b	Lithium manganese nickel cobalt oxide											
c	Soft carbon											
d	Forced internal short circuit test (IEC 62660-3:2016, 6.4.4.2.1)											
e	Positive electrode											
f	Negative electrode											
g	Plug-in hybrid electric vehicle											
h	Nickel-cobalt-aluminium											
i	Lithium manganese acid											

A.2.2 Data of each test

A.2.2.1 Tests on cell A and cell B

A.2.2.1.1 FISC test result on cell A

The tests 1-1, 1-2 and 1-3 in Table A.1 are conducted according to 6.4.4.2.1 of IEC 62660-3:2016, with three samples of cell A (HC/MNC, 5 Ah, for HEV application). The test data are shown in Figure A.1, Figure A.2, Figure A.3, and Table A.1. Figure "a" of each figure shows the voltage and temperature change of cell within 1 h, and "b" is the magnified figure showing the voltage change when the short circuit occurs.

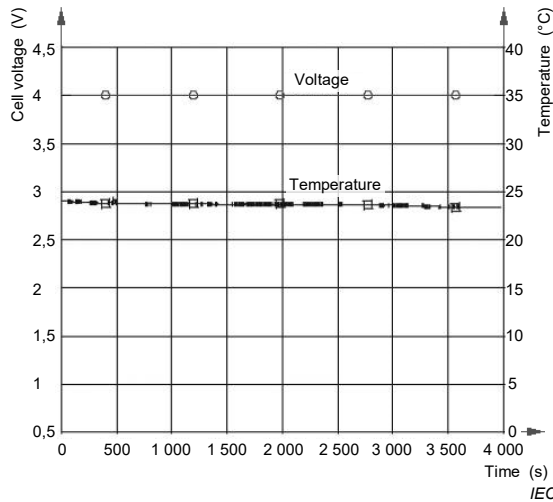

Figure A.1a

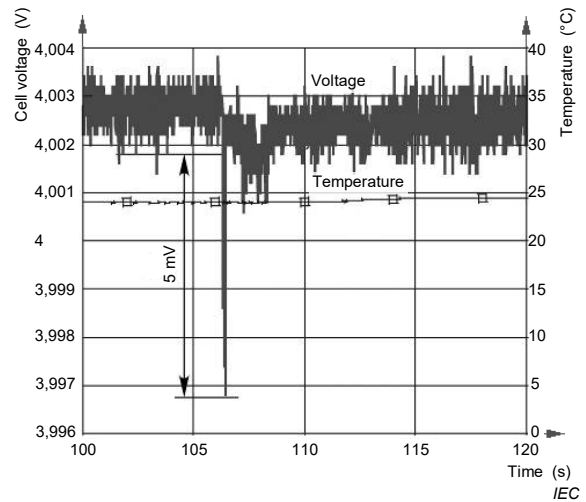

Figure A.1b

SOURCE: Japan Automobile Research Institute (JARI) acquired these data under the Project for the Promotion of New Energy Infrastructure Development in FY 2014, entrusted by Agency for Natural Resources and Energy / Mitsubishi Research Institute, Inc.

Figure A.1 – Voltage and temperature of test 1-1

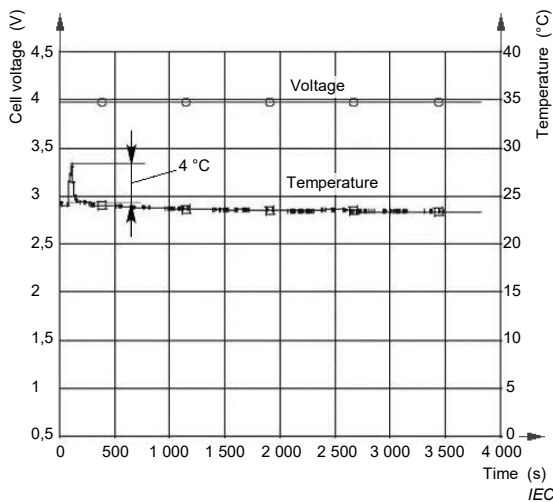

Figure A.2a

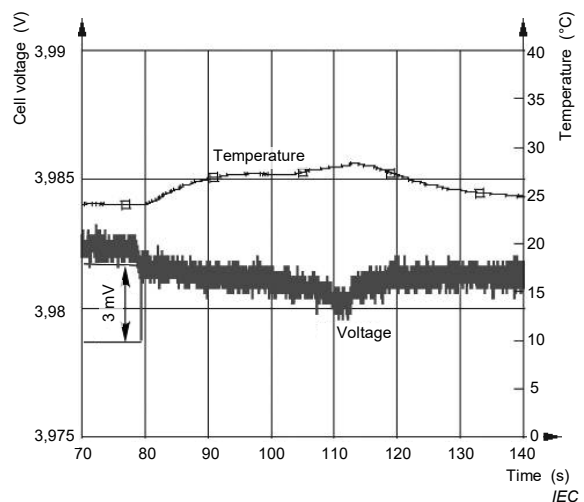

Figure A.2b

SOURCE: Japan Automobile Research Institute (JARI) acquired these data under the Project for the Promotion of New Energy Infrastructure Development in FY 2014, entrusted by Agency for Natural Resources and Energy / Mitsubishi Research Institute, Inc.

Figure A.2 – Voltage and temperature of test 1-2

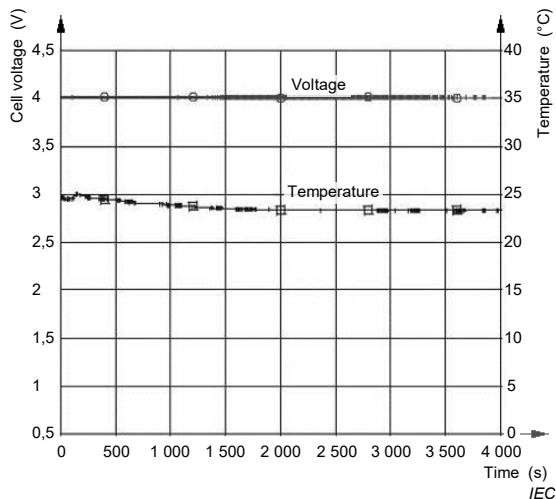

Figure A.3a

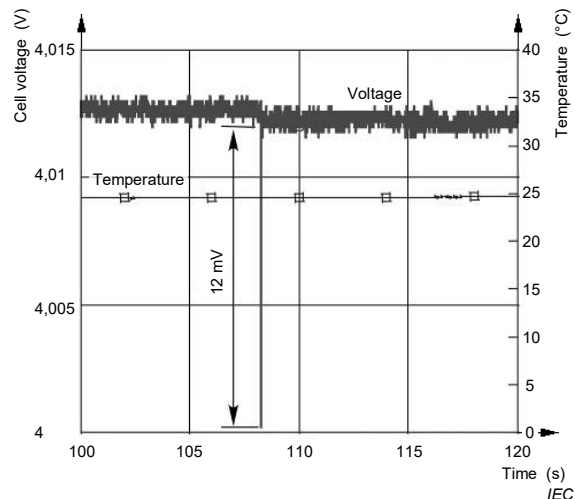

Figure A.3b

SOURCE: Japan Automobile Research Institute (JARI) acquired these data under the Project for the Promotion of New Energy Infrastructure Development in FY 2014, entrusted by Agency for Natural Resources and Energy / Mitsubishi Research Institute, Inc.

Figure A.3 – Voltage and temperature of test 1-3

A.2.2.1.2 Tests with type 2 indenter

The tests 2-1, 2-2 and 2-3 in Table A.1 are conducted according to Clause 5 using type 2 indenter, on two types of cells: cell A and cell B (SC/MNC, 5 Ah, for HEV application). Test data are shown in Figure A.4, Figure A.5, Figure A.6 and Table A.1. The short circuit phenomena of test 2-1 and test 2-2 were more severe than FISC test in A.2.2.1.1. Test 2-3 was stopped at the voltage drop of 2 mV, and achieved almost the same result as the FISC test.

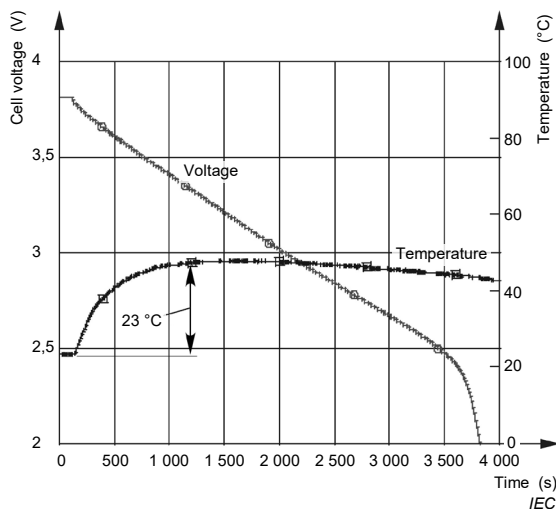

Figure A.4a

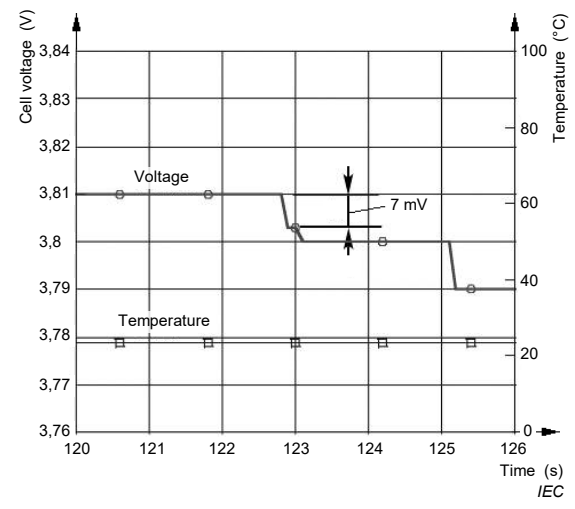

Figure A.4b

Figure A.4 – Voltage and temperature of test 2-1

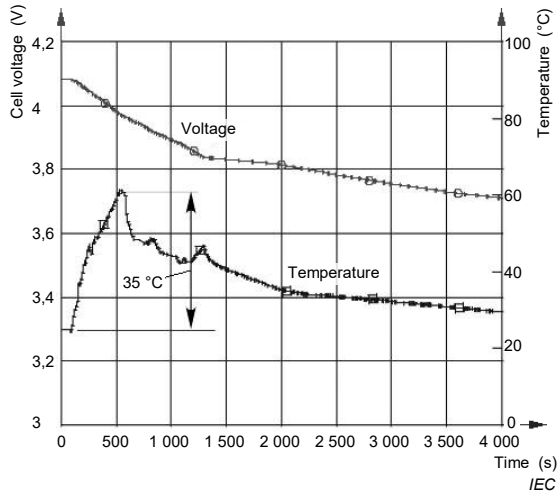

Figure A.5a

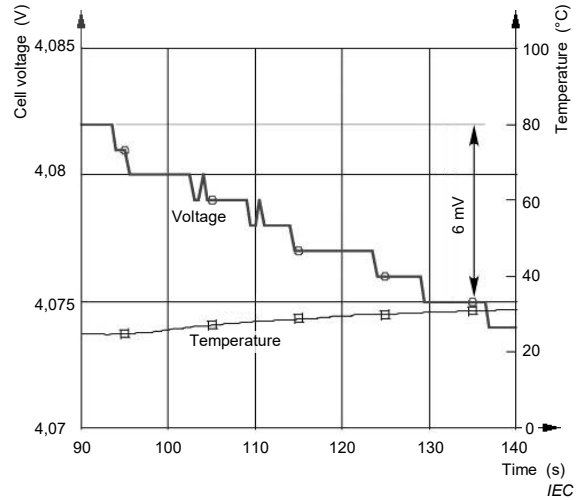

Figure A.5b

Figure A.5 – Voltage and temperature of test 2-2

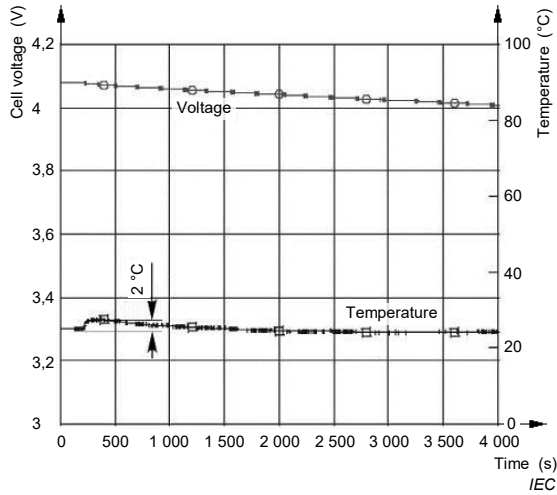

Figure A.6a

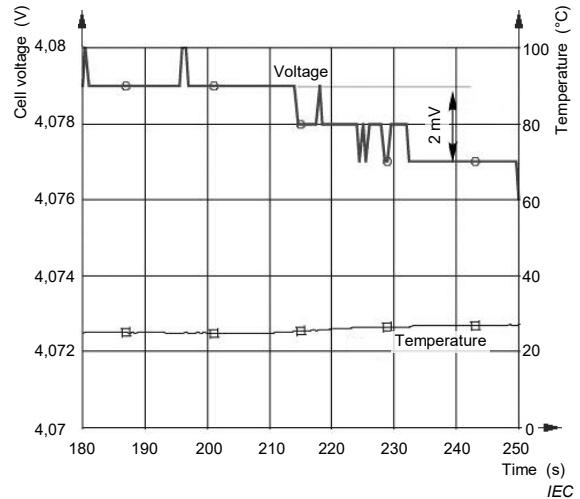

Figure A.6b

Figure A.6 – Voltage and temperature of test 2-3

A.2.2.1.3 Comparison tests of ceramic nails with or without Ni tip

The tests 3-1 and 3-2 in Table A.1 are conducted on cell A using type 2 indenter and the 1 mm-diameter ceramic nail without Ni tip. The test end condition was the voltage drop of 20 mV. The test data are shown in Figure A.7, Figure A.8 and Table A.1. The results of both tests are almost the same in the presence or absence of Ni tip.

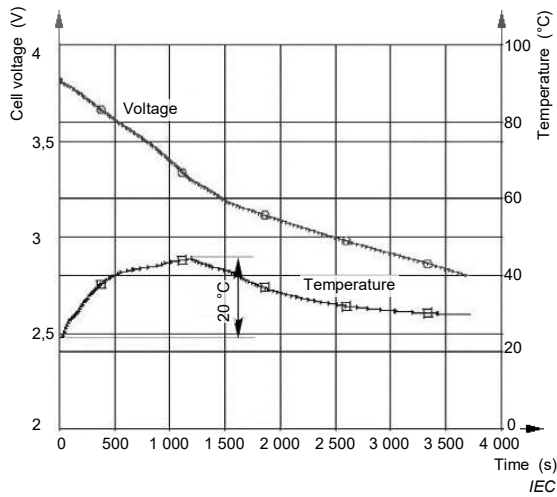

Figure A.7a

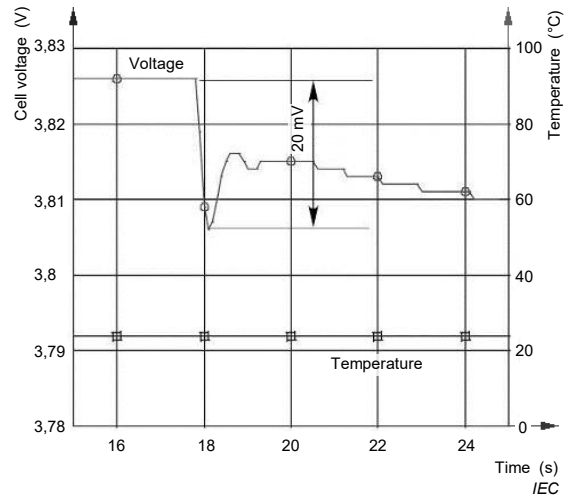

Figure A.7b

Figure A.7 – Voltage and temperature of test 3-1

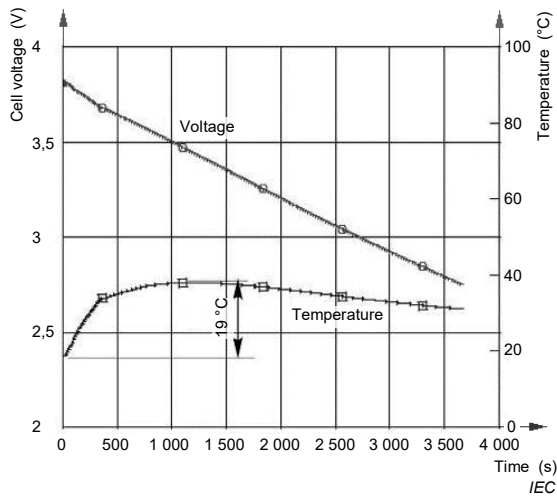

Figure A.8a

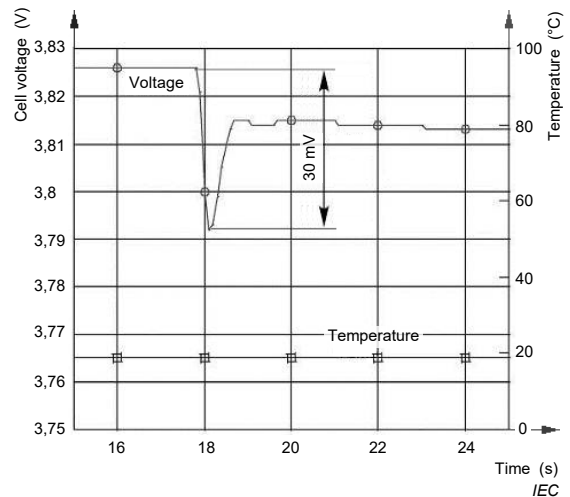

Figure A.8b

Figure A.8 – Voltage and temperature of test 3-2

A.2.2.1.4 Comparison of indenters with different size

The test 4 in Table A.1 is conducted on cell A using a 3 mm-diameter ceramic nail with Ni tip as shown in Figure A.9. The indenter was automatically stopped when the voltage drop of 2 mV or more was detected. The test data are shown in Figure A.10 and Table A.1.

Dimensions in millimetres

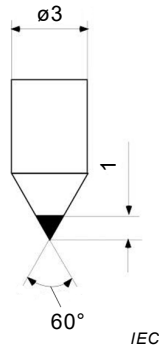

Figure A.9 – ø3 mm ceramic nail with Ni tip

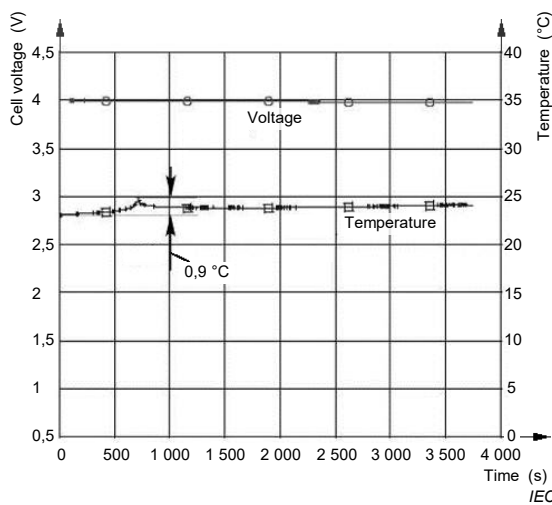

Figure A.10a

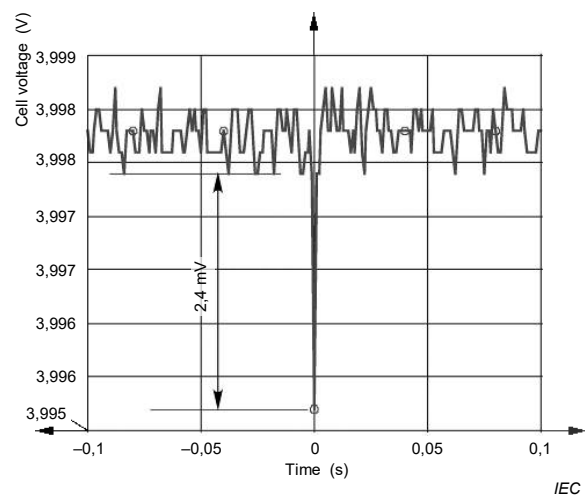

Figure A.10b

SOURCE: Japan Automobile Research Institute (JARI) acquired these data under the Project for the Promotion of New Energy Infrastructure Development in FY 2014, entrusted by Agency for Natural Resources and Energy / Mitsubishi Research Institute, Inc.

Figure A.10 – Voltage and temperature of test 4

A.2.2.1.5 Comparison of test stop condition

The tests 5-1 and 5-2 in Table A.1 are conducted on cell A, using a 3 mm-diameter ceramic nail with Ni tip, and with different test stop conditions of voltage drop. According to 5.1.3, the indenter should be stopped when at least 5 mV voltage drop is detected. The test 5-1 in Figure A.11 was stopped when 5 mV voltage drop was detected, and the test 5-2 in Figure A.12 was stopped when 20 mV voltage drop was detected. The data of both tests show that the internal short circuit of fewer layers can be simulated when the test is stopped at smaller voltage drop.

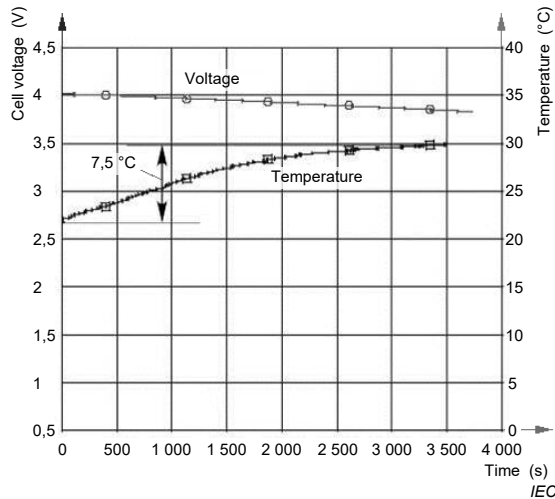

Figure A.11a

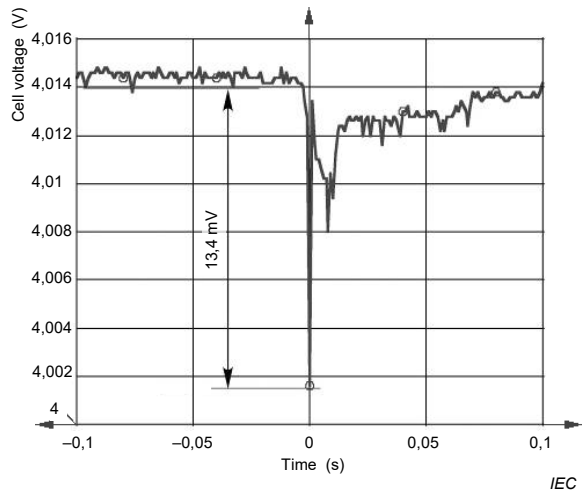

Figure A.11b

SOURCE: Japan Automobile Research Institute (JARI) acquired these data under the Project for the Promotion of New Energy Infrastructure Development in FY 2014, entrusted by Agency for Natural Resources and Energy / Mitsubishi Research Institute, Inc.

Figure A.11 – Voltage and temperature of test 5-1

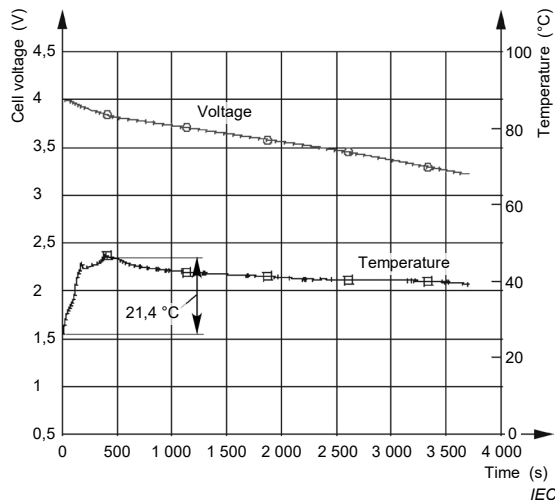

Figure A.12a

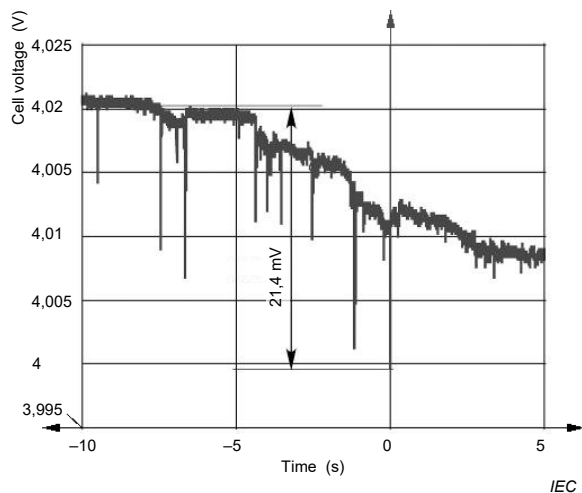

Figure A.12b

SOURCE: Japan Automobile Research Institute (JARI) acquired these data under the Project for the Promotion of New Energy Infrastructure Development in FY 2014, entrusted by Agency for Natural Resources and Energy / Mitsubishi Research Institute, Inc.

Figure A.12 – Voltage and temperature of test 5-2

A.2.2.2 Tests on cell C and cell D

A.2.2.2.1 Test with type 2 indenter

The tests from 6-1 to 6-5 in Table A.1 are conducted according to Clause 5 using type 2 indenter on Cell C (pouch cell for BEV application). The voltage data are shown in Figure A.13.

The tests from 7-1 to 7-5 in Table A.1 are conducted according to Clause 5 using type 2 indenter on Cell D (pouch cell for HEV application). The voltage data are shown in Figure A.14.

The results of comparison test according to 6.4.4.2.1 of IEC 62660-3:2016 (FISC) are also shown as tests 10-1 and 10-2 in Table A.1, and Figures A.13, A.14, A.18 and A.19. In comparison with the FISC test, the tests 6 and 7 resulted in higher value in voltage drop, temperature rise, and number of short circuited layers.

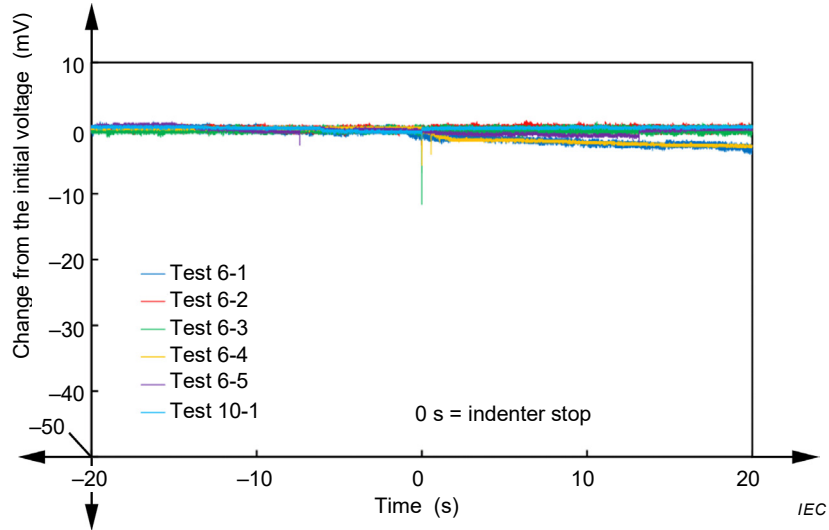

Figure A.13 – Voltage data of tests 6

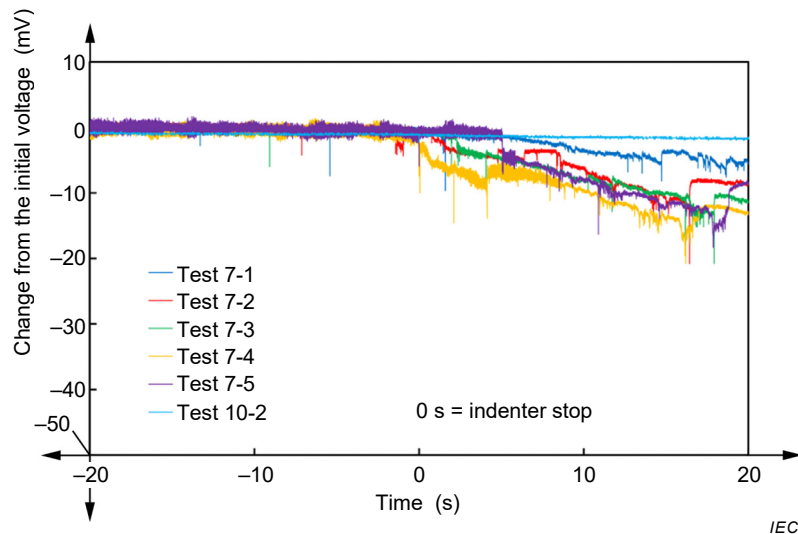

Figure A.14 – Voltage data of tests 7

A.2.2.2.2 Test with Type 1 indenter and comparison with different nail tip angle

The tests from 8-1 to 8-5 in Table A.1 are conducted on cell C, according to Clause 5 using type 1 indenter and a ceramic nail with 3 mm diameter and 20° angle. The voltage data are shown in Figure A.15.

The tests from 9-1 to 9-5 in Table A.1 are conducted on cell D, according to Clause 5 using type 1 indenter and a ceramic nail with 3 mm diameter and 20° angle. The voltage data are shown in Figure A.16.

The test data show that the difference in nail tip angle has little impact on the test results, at least for cell C and cell D.

In comparison with the FISC test, the tests 8 and 9 resulted in higher value in voltage drop, temperature rise, and number of short circuited layers.

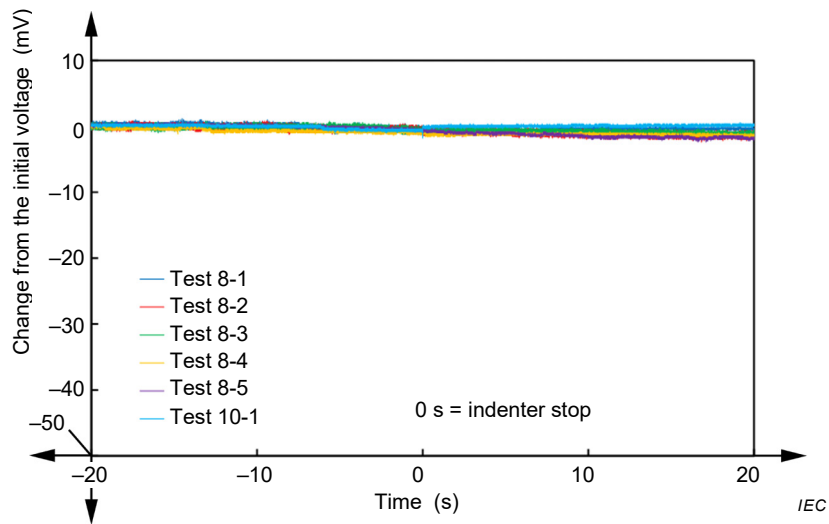

Figure A.15 – Voltage data of tests 8

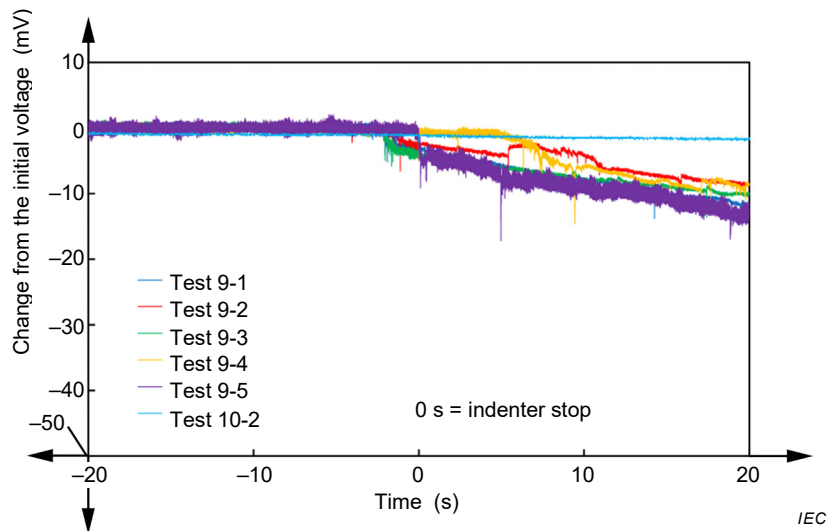

Figure A.16 – Voltage data of tests 9

A.2.2.2.3 FISC test results on cell C and cell D

The tests 10-1 and 10-2 in Table A.1 are conducted according to 6.4.4.2.1 of IEC 62660-3:2016, with one sample of cell C and cell D. The voltage data are shown in Figure A.17 and Figure A.18.

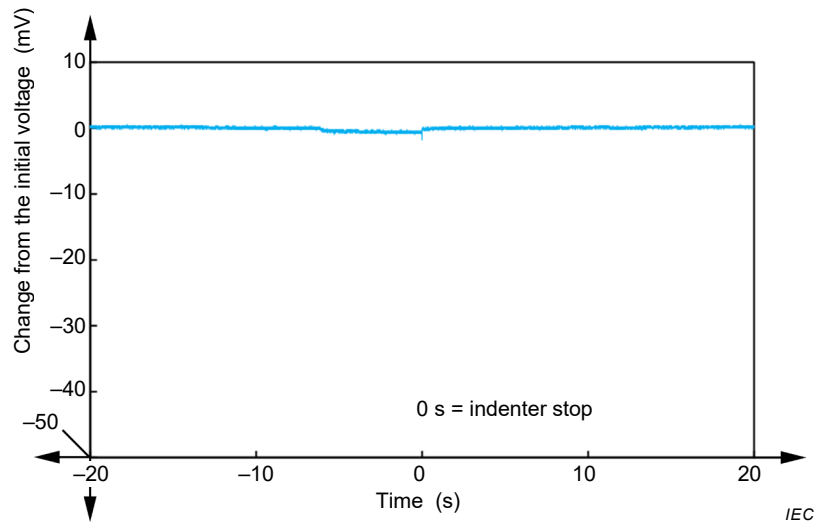

Figure A.17 – Voltage data of tests 10-1

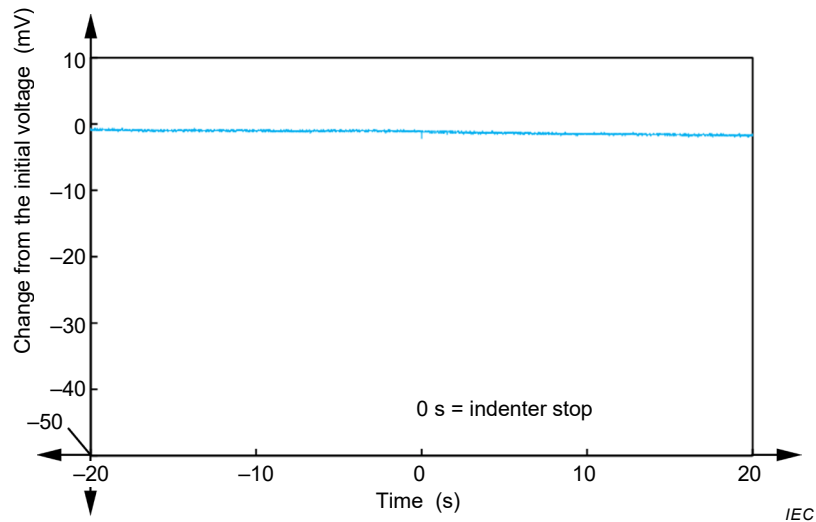

Figure A.18 – Voltage data of tests 10-2

A.2.2.3 Tests on cell E and cell F

A.2.2.3.1 FISC test result

The tests 11-1 and 11-2 in Table A.1 are conducted according to 6.4.4.2.1 of IEC 62660-3:2016, with cell E (graphite/MNC, 21,5 Ah, for PHEV application) and cell F (graphite/NCA, 5 Ah, for HEV application), respectively. The voltage data are shown in Figure A.19 and Figure A.20. Figure "a" of each figure shows the voltage change of cell within 500 s, and "b" is the magnified figure showing the voltage change when the short circuit occurs.

Both cells passed the acceptance criteria. Number of short circuited layers in both tests is no positive electrode and one negative electrode.

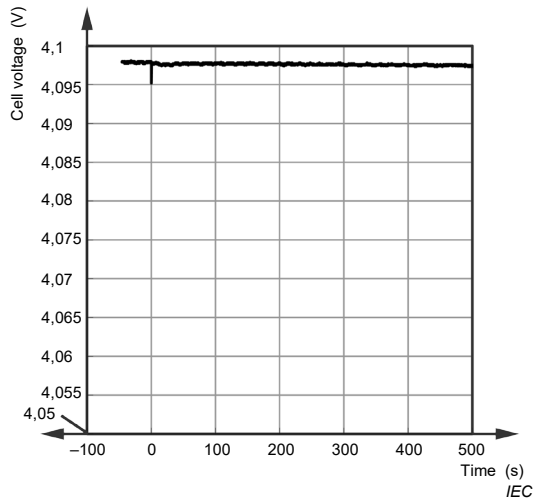

Figure A.19a

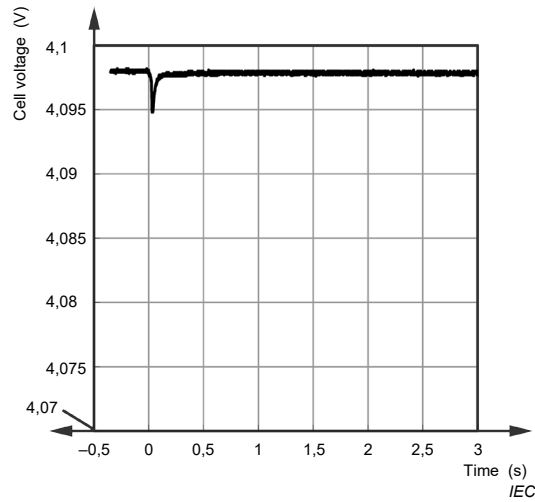

Figure A.19b

Figure A.19 – Voltage data of test 11-1

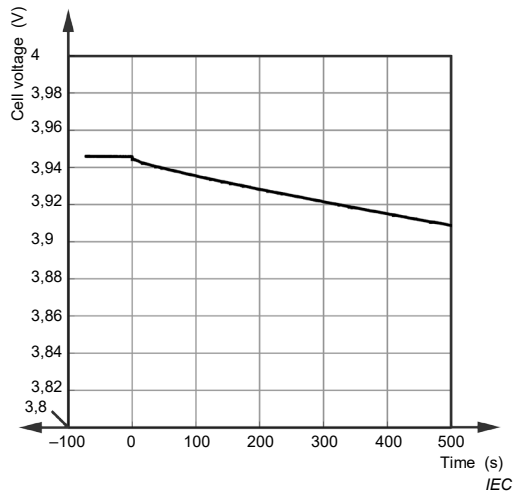

Figure A.20a

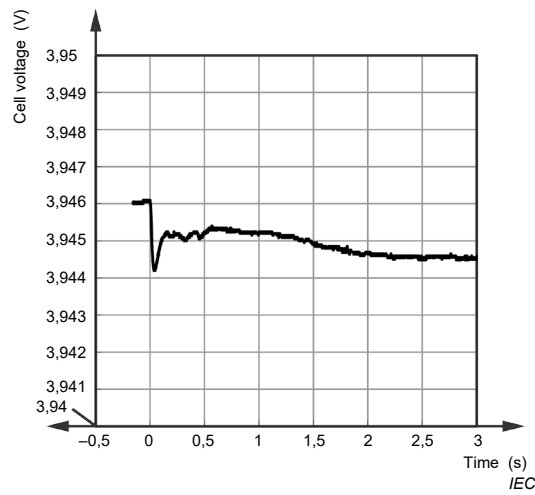

Figure A.20b

Figure A.20 – Voltage data of test 11-2

A.2.2.3.2 Tests with type 2 indenter and comparison of indenters with different size

The tests from 12-1 to 12-7 in Table A.1 are conducted on cell E according to Clause 5 using type 2 indenter and different sizes of ceramic nails with Ni tip. The voltage data are shown from Figure A.21 to Figure A.27. The indenters are ceramic nails having a diameter of 1 mm and 3 mm, with a Ni tip of 0,35 mm or 1 mm in height. The angle of the Ni tip is 30°, 45° or 60°. Press speed varies from 0,001 mm/s to 0,1mm/s.

The test 13 in Table A.1 is conducted on cell F, according to Clause 5 using a ceramic nail having a diameter of 3 mm with a Ni tip of 1 mm in height, and 30° angle. The voltage data are shown in Figure A.28.

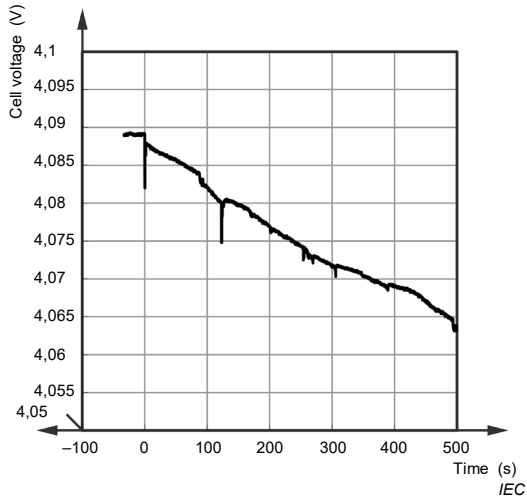

Figure A.21a

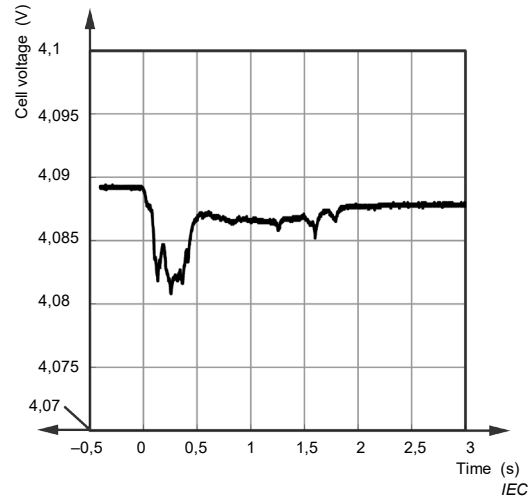

Figure A.21b

Figure A.21 – Voltage data of test 12-1

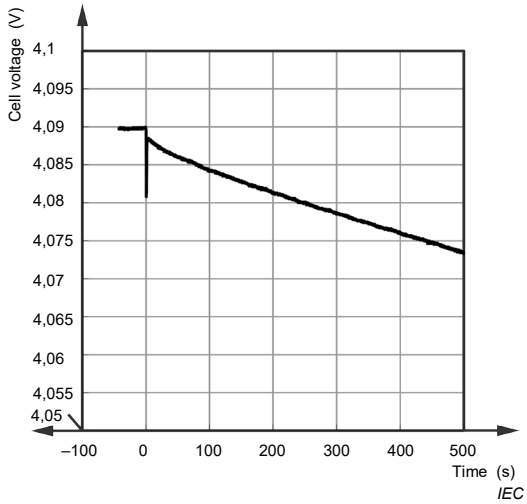

Figure A.22a

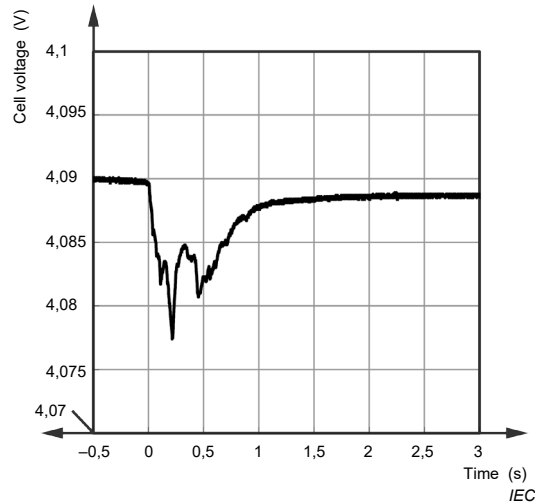

Figure A.22b

Figure A.22 – Voltage data of test 12-2

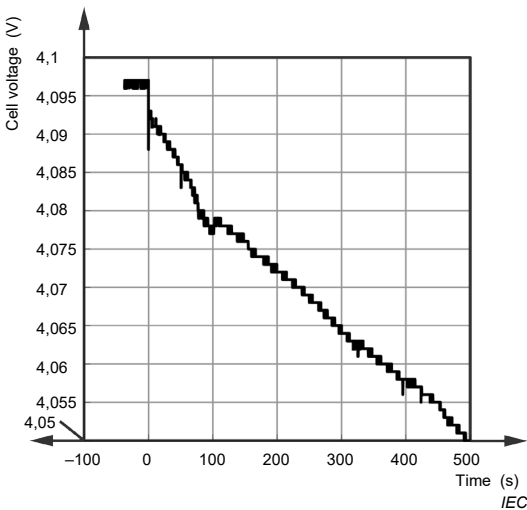

Figure A.23a

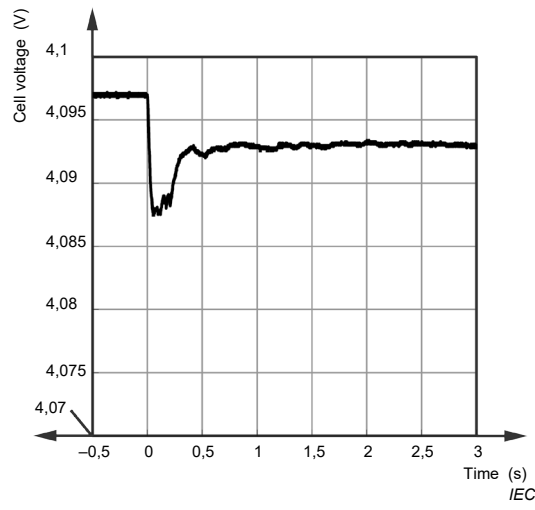

Figure A.23b

Figure A.23 – Voltage data of test 12-3

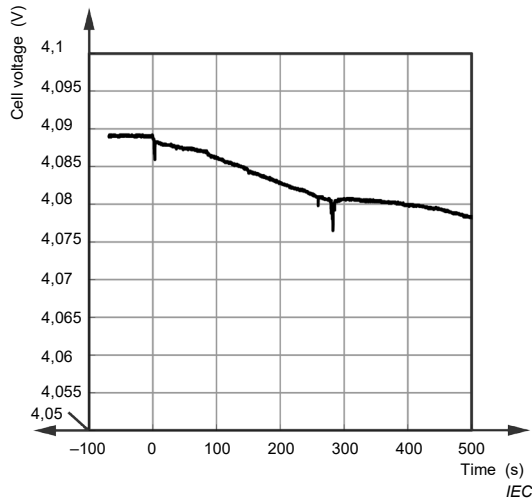

Figure A.24a

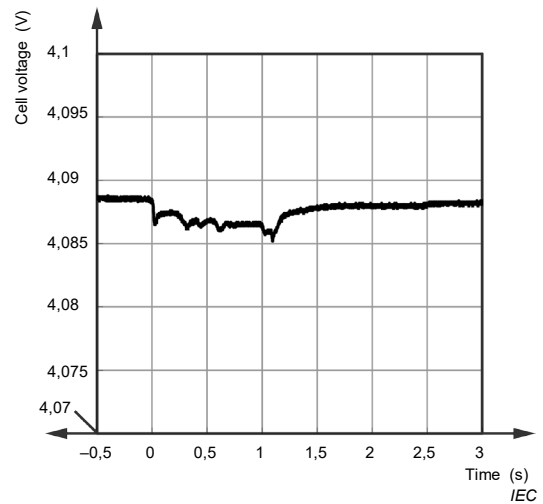

Figure A.24b

Figure A.24 – Voltage data of test 12-4

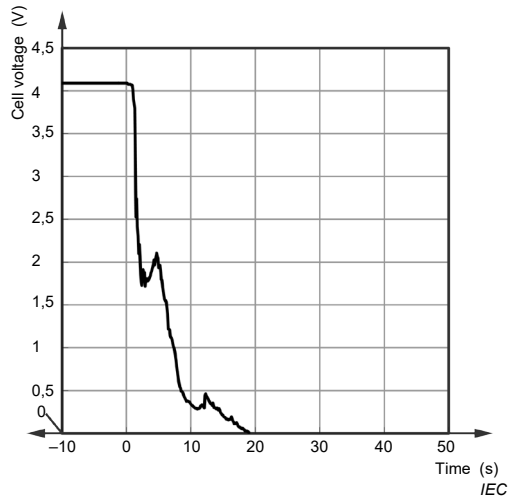

Figure A.25a

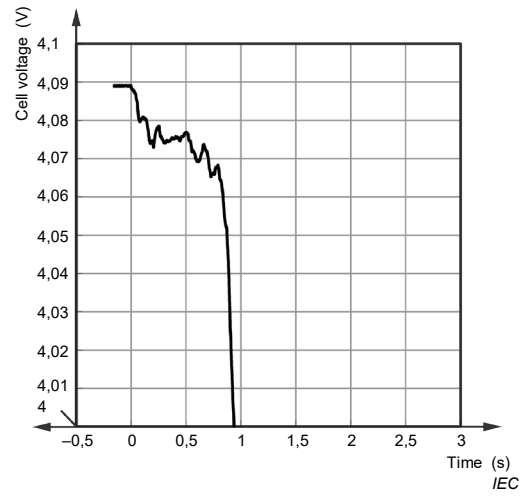

Figure A.25b

Figure A.25 – Voltage data of test 12-5

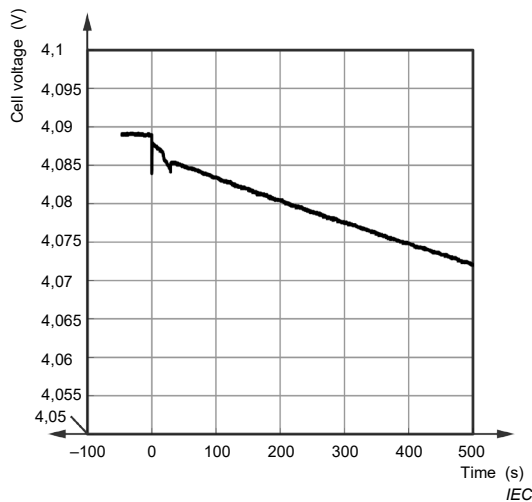

Figure A.26a

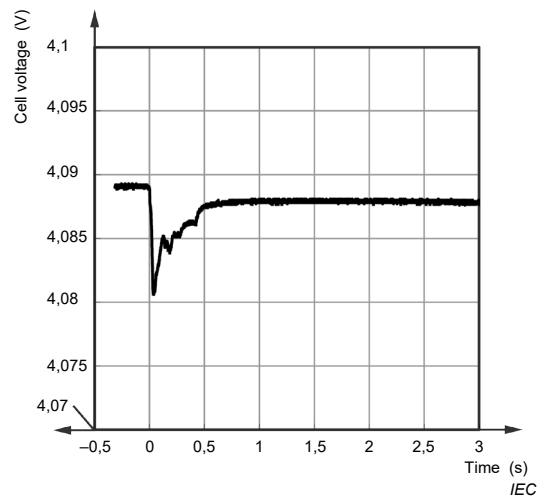

Figure A.26b

Figure A.26 – Voltage data of test 12-6

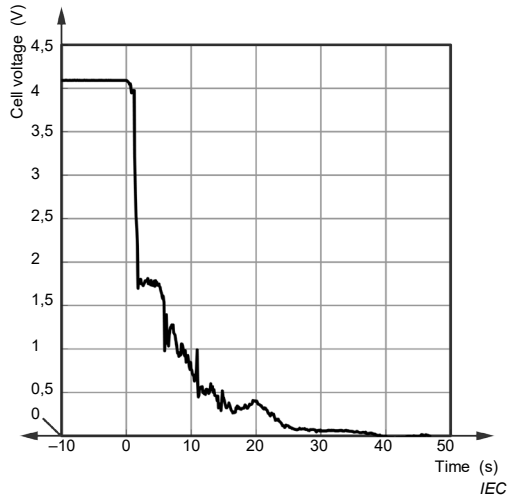

Figure A.27a

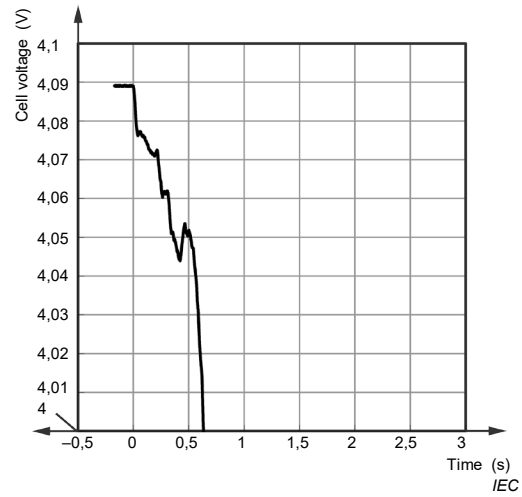

Figure A.27b

Figure A.27 – Voltage data of test 12-7

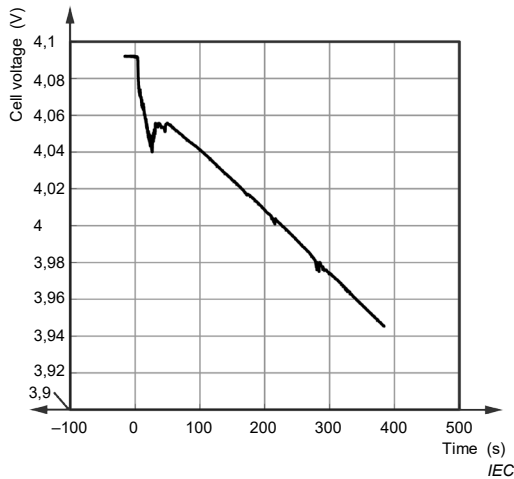

Figure A.28a

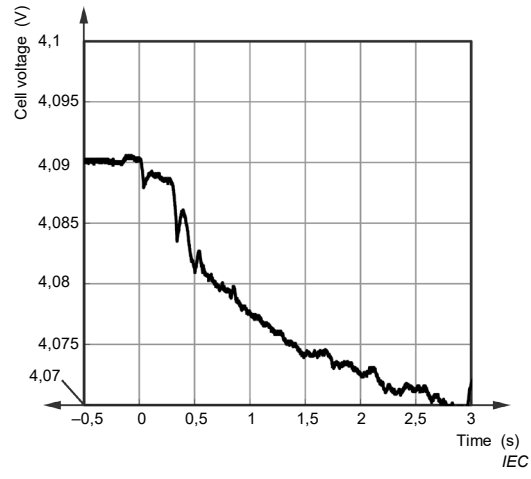

Figure A.28b

Figure A.28 – Voltage data of test 13

A.2.2.4 Tests on cell G

The tests from 14-1 to 14-5 in Table A.1 are conducted on cell G (graphite/MNC and LMO, 60 Ah, with copper plate between case and rolled electrodes, for PHEV application) according to Clause 5 using type 2 indenter and a ceramic nail having a diameter of 3 mm with a Ni tip of 1 mm in height, and 45° angle. The cell cases are thinned, and vary from 0 mm to 0,85 mm. Press speed is 0,01 mm/s or 0,1 mm/s. The voltage data are shown in Figure A.29, Figure A.30, Figure A.31, Figure A.32 and Figure A.33.

The test results differed depending on the case thickness. In tests 14-1 and 14-2, where the case is relatively thick, the cells exhibited fire. Further, in tests from 14-1 to 14-3, the short circuit occurred only between the case and the copper plate between case and rolled electrodes, and no layer was short circuited.

In tests from 14-3 to 14-5, where the case is relatively thin, and type 2 indenter is used, there was no fire and no smoke, while the number of short circuited layers differed.

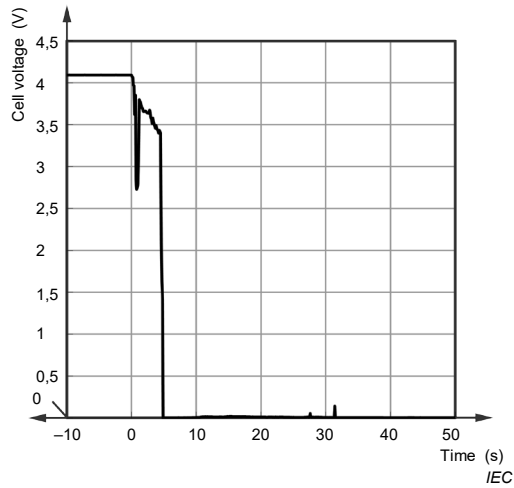

Figure A.29a

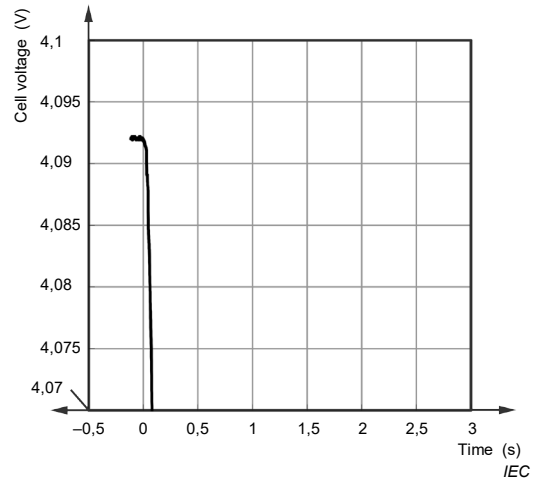

Figure A.29b

Figure A.29 – Voltage data of test 14-1

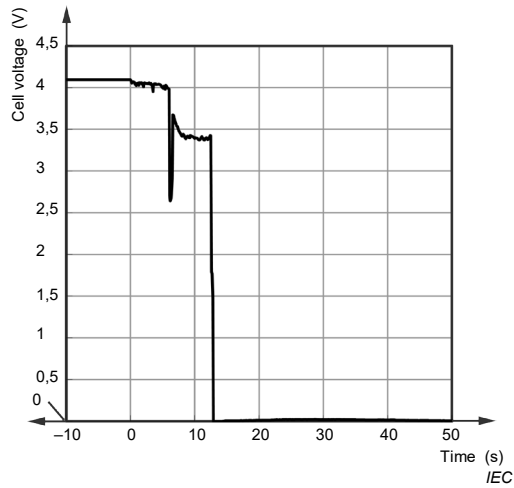

Figure A.30a

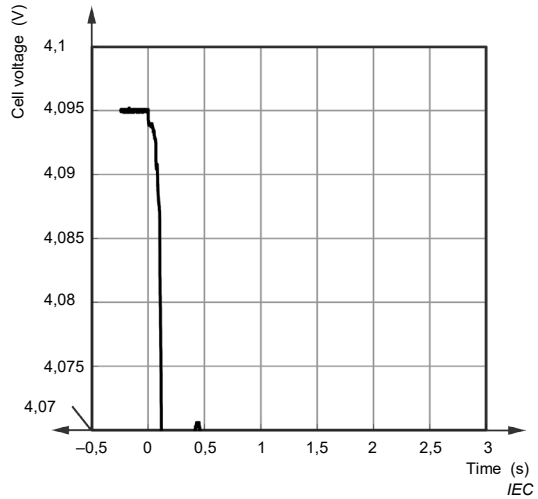

Figure A.30b

Figure A.30 – Voltage data of test 14-2

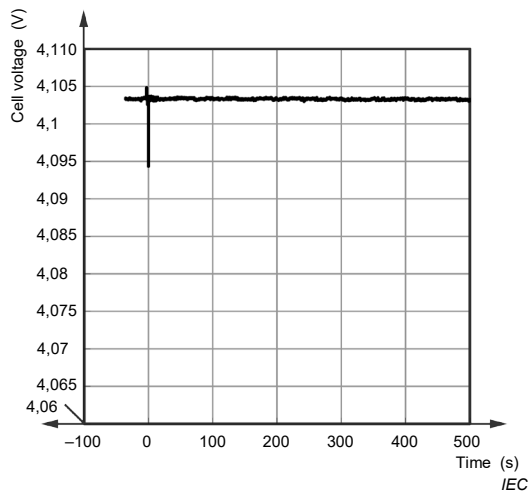

Figure A.31a

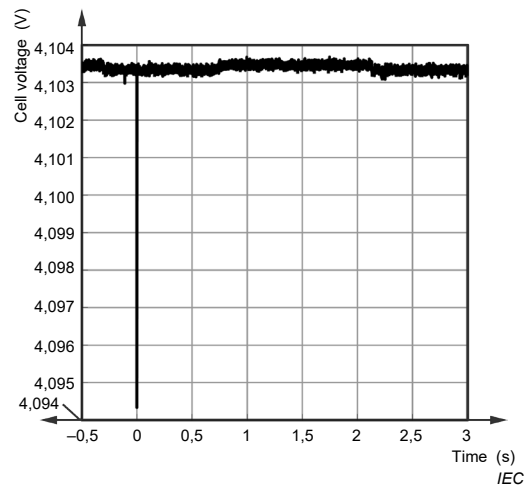

Figure A.31b

Figure A.31 – Voltage data of test 14-3

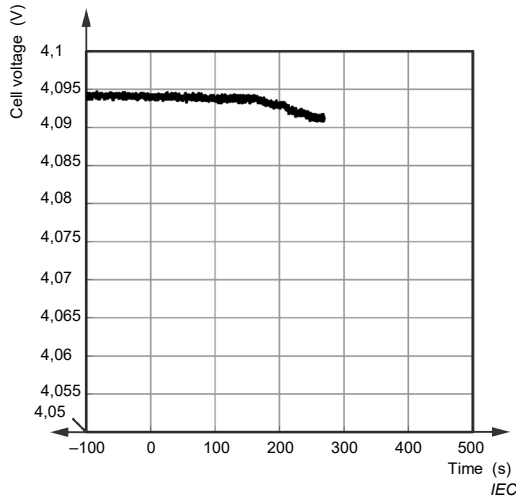

Figure A.32a

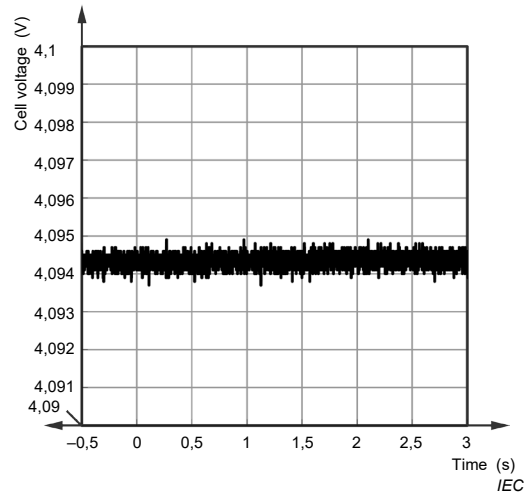

Figure A.32b

Figure A.32 – Voltage data of test 14-4

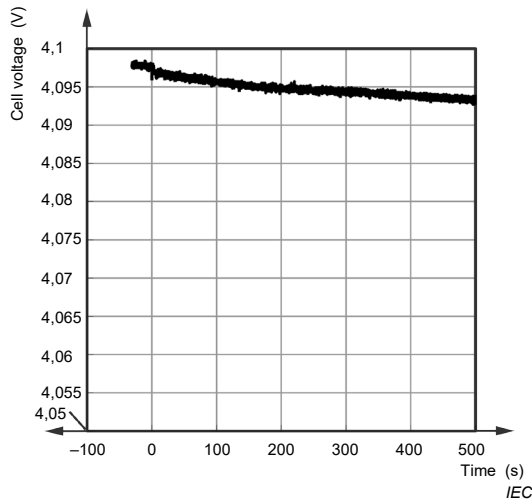

Figure A.33a

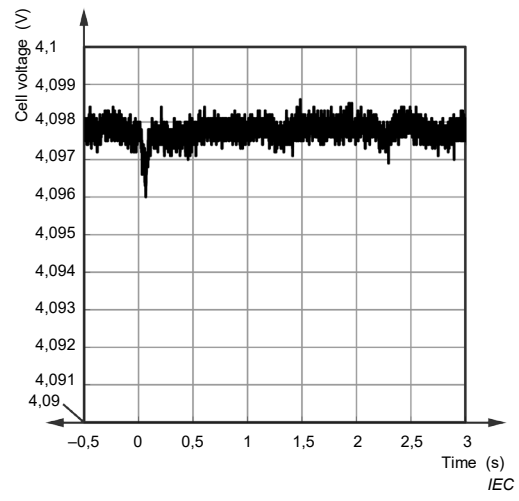

Figure A.33b

Figure A.33 – Voltage data of test 14-5

A.2.2.5 Tests on cell H

A.2.2.5.1 Tests with Type 1 indenter

The tests from 15-1 to 15-5 in Table A.1 are conducted on cell H (graphite/MNC, 37 Ah for PHEV application) according to Clause 5 using Type 1 indenter. The test data are shown in Figure A.34.

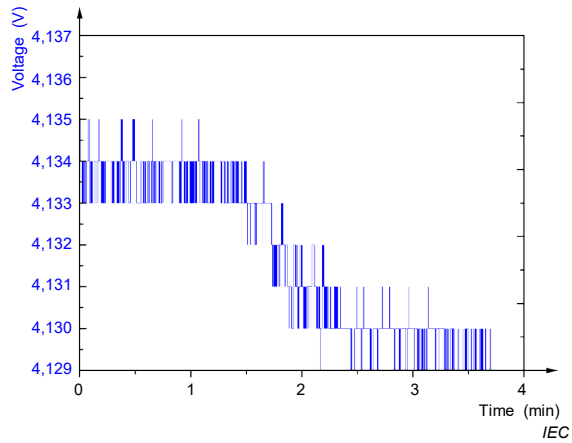

Figure A.34a

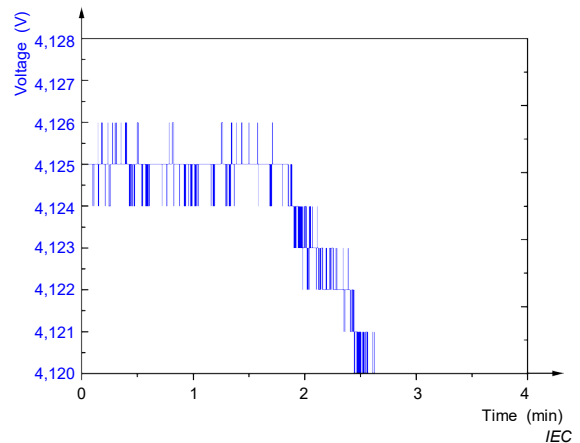

Figure A.34b

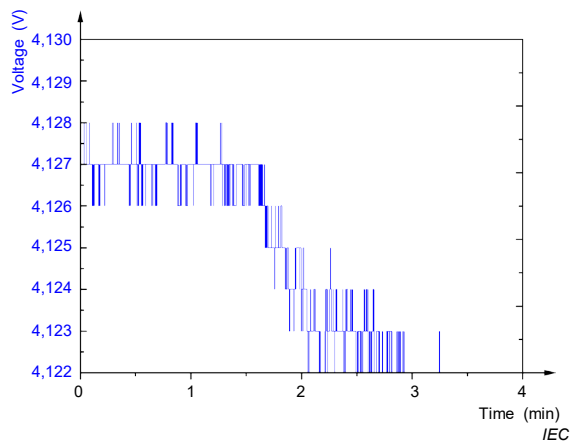

Figure A.34c

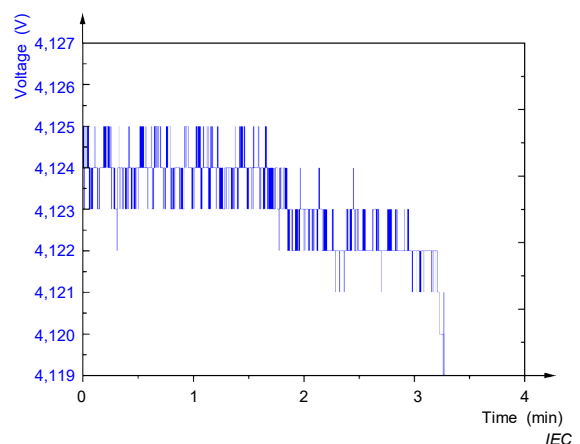

Figure A.34d

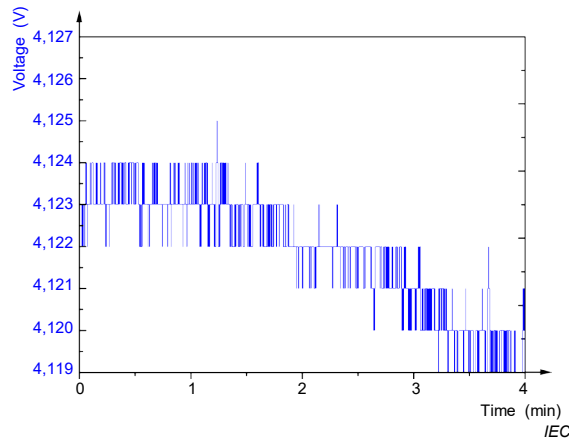

Figure A.34e

Figure A.34 – Voltage data of tests 15

A.2.2.5.2 Tests with Type 2 indenter

The tests from 16-1 to 16-5 in Table A.1 are conducted on cell H (graphite/MNC, 37 Ah for PHEV application) according to Clause 5 using Type 2 indenter. The test data are shown in Figure A.35.

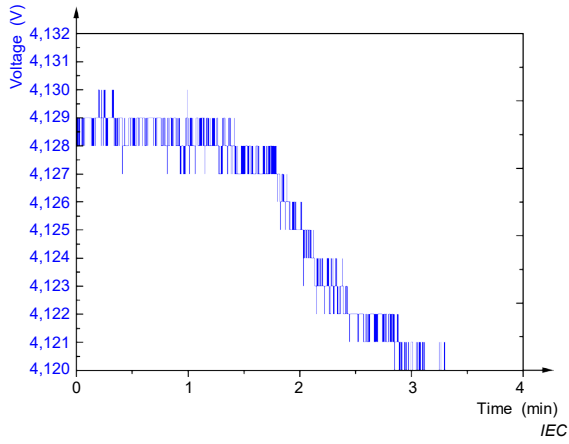

Figure A.35a

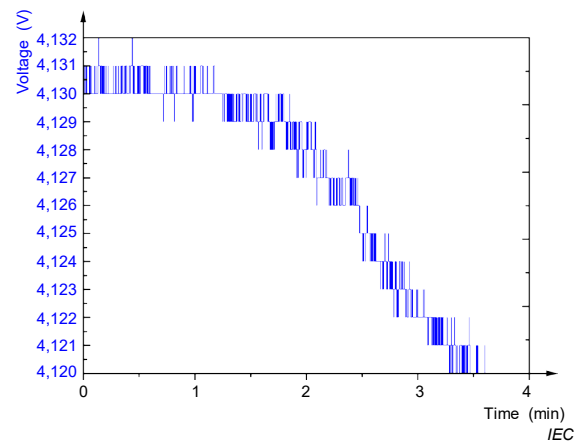

Figure A.35b

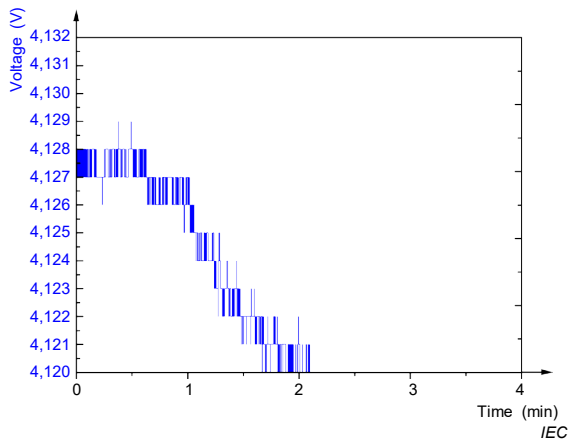

Figure A.35c

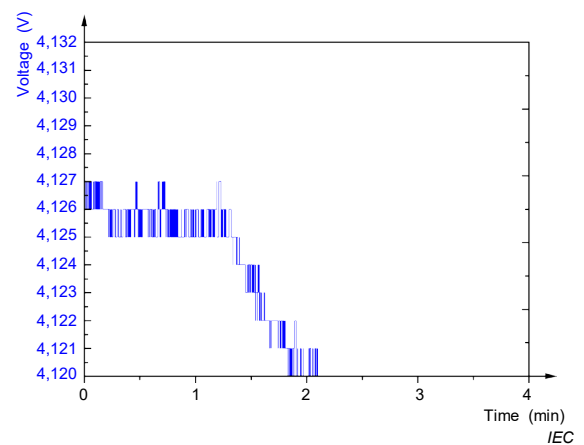

Figure A.35d

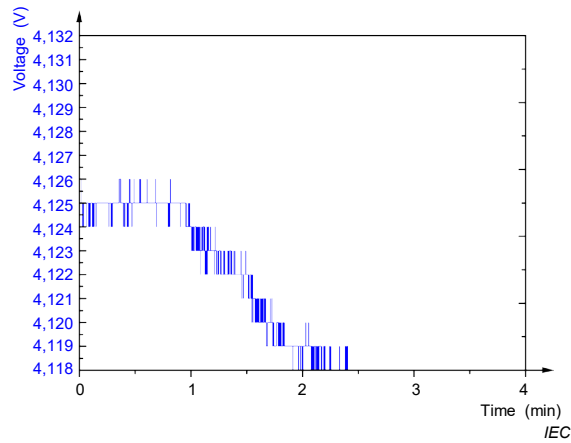

Figure A.35e

Figure A.35 – Voltage data of tests 16

British Standards Institution (BSI)

BSI is the national body responsible for preparing British Standards and other standards-related publications, information and services.

BSI is incorporated by Royal Charter. British Standards and other standardization products are published by BSI Standards Limited.

About us

We bring together business, industry, government, consumers, innovators and others to shape their combined experience and expertise into standards-based solutions.

The knowledge embodied in our standards has been carefully assembled in a dependable format and refined through our open consultation process. Organizations of all sizes and across all sectors choose standards to help them achieve their goals.

Information on standards

We can provide you with the knowledge that your organization needs to succeed. Find out more about British Standards by visiting our website at bsigroup.com/standards or contacting our Customer Services team or Knowledge Centre.

Buying standards

You can buy and download PDF versions of BSI publications, including British and adopted European and international standards, through our website at bsigroup.com/shop, where hard copies can also be purchased.

If you need international and foreign standards from other Standards Development Organizations, hard copies can be ordered from our Customer Services team.

Copyright in BSI publications

All the content in BSI publications, including British Standards, is the property of and copyrighted by BSI or some person or entity that owns copyright in the information used (such as the international standardization bodies) and has formally licensed such information to BSI for commercial publication and use.

Save for the provisions below, you may not transfer, share or disseminate any portion of the standard to any other person. You may not adapt, distribute, commercially exploit, or publicly display the standard or any portion thereof in any manner whatsoever without BSI's prior written consent.

Storing and using standards

Standards purchased in soft copy format:

- A British Standard purchased in soft copy format is licensed to a sole named user for personal or internal company use only.
- The standard may be stored on more than 1 device provided that it is accessible by the sole named user only and that only 1 copy is accessed at any one time.
- A single paper copy may be printed for personal or internal company use only.

Standards purchased in hard copy format:

- A British Standard purchased in hard copy format is for personal or internal company use only.
- It may not be further reproduced – in any format – to create an additional copy. This includes scanning of the document.

If you need more than 1 copy of the document, or if you wish to share the document on an internal network, you can save money by choosing a subscription product (see 'Subscriptions').

Reproducing extracts

For permission to reproduce content from BSI publications contact the BSI Copyright & Licensing team.

Subscriptions

Our range of subscription services are designed to make using standards easier for you. For further information on our subscription products go to bsigroup.com/subscriptions.

With **British Standards Online (BSOL)** you'll have instant access to over 55,000 British and adopted European and international standards from your desktop. It's available 24/7 and is refreshed daily so you'll always be up to date.

You can keep in touch with standards developments and receive substantial discounts on the purchase price of standards, both in single copy and subscription format, by becoming a **BSI Subscribing Member**.

PLUS is an updating service exclusive to BSI Subscribing Members. You will automatically receive the latest hard copy of your standards when they're revised or replaced.

To find out more about becoming a BSI Subscribing Member and the benefits of membership, please visit bsigroup.com/shop.

With a **Multi-User Network Licence (MUNL)** you are able to host standards publications on your intranet. Licences can cover as few or as many users as you wish. With updates supplied as soon as they're available, you can be sure your documentation is current. For further information, email subscriptions@bsigroup.com.

Revisions

Our British Standards and other publications are updated by amendment or revision.

We continually improve the quality of our products and services to benefit your business. If you find an inaccuracy or ambiguity within a British Standard or other BSI publication please inform the Knowledge Centre.

Useful Contacts

Customer Services

Tel: +44 345 086 9001

Email (orders): orders@bsigroup.com

Email (enquiries): cservices@bsigroup.com

Subscriptions

Tel: +44 345 086 9001

Email: subscriptions@bsigroup.com

Knowledge Centre

Tel: +44 20 8996 7004

Email: knowledgecentre@bsigroup.com

Copyright & Licensing

Tel: +44 20 8996 7070

Email: copyright@bsigroup.com

BSI Group Headquarters

389 Chiswick High Road London W4 4AL UK