

PD IEC/TR 61912-2:2009

BSI British Standards

Low-voltage switchgear and controlgear — Over-current protective devices —

Part 2: Selectivity under over-current conditions

NO COPYING WITHOUT BSI PERMISSION EXCEPT AS PERMITTED BY COPYRIGHT LAW

raising standards worldwide™

BSi
British Standards

National foreword

This Published Document is the UK implementation of IEC/TR 61912-2:2009.

The UK participation in its preparation was entrusted by Technical Committee PEL/17, Switchgear, controlgear, and HV-LV co-ordination, to Subcommittee PEL/17/2, Low voltage switchgear and controlgear.

A list of organizations represented on this committee can be obtained on request to its secretary.

This publication does not purport to include all the necessary provisions of a contract. Users are responsible for its correct application.

© BSI 2009

ISBN 978 0 580 57667 6

ICS 29.130.01

Compliance with a British Standard cannot confer immunity from legal obligations.

This Published Document was published under the authority of the Standards Policy and Strategy Committee on 31 July 2009

Amendments issued since publication

Amd. No.	Date	Text affected
----------	------	---------------



TECHNICAL REPORT

Low-voltage switchgear and controlgear – Over-current protective devices – Part 2: Selectivity under over-current conditions

INTERNATIONAL
ELECTROTECHNICAL
COMMISSION

PRICE CODE



ICS 29.130

ISBN 2-8318-1042-0

CONTENTS

FOREWORD.....	4
INTRODUCTION.....	6
1 Scope.....	7
2 Normative references.....	7
3 Terms, definitions and abbreviated terms.....	8
3.1 Alphabetical index of terms.....	8
3.2 Terms and definitions.....	9
3.3 Abbreviated terms.....	10
4 Scope of selectivity requirements.....	11
4.1 General.....	11
4.2 Motor protection circuit-breaker / Manual motor starter.....	12
5 Selectivity determination.....	12
5.1 Circuit-breaker as UD.....	12
5.1.1 Selectivity between circuit-breakers.....	12
5.1.2 Selectivity between a circuit-breaker (UD) and a fuse to IEC 60269-1 (DD).....	15
5.1.3 CB/CPS – Selectivity between a circuit-breaker to IEC 60947-2 (UD) and a CPS to IEC 60947-6-2 (DD).....	16
5.1.4 Circuit-breaker/MOR – Selectivity between a circuit-breaker (UD) and a motor protection overload relay to IEC 60947-4-1 or IEC 60947-4-2 (DD).....	17
5.2 Fuse(s) to IEC 60269-1 as UD.....	18
5.2.1 Fuse/circuit-breaker – Selectivity between a fuse to IEC 60269-1 (UD) and a circuit-breaker (DD).....	18
5.2.2 FU/FU – Selectivity between fuses to IEC 60269-1 (UD and DD).....	20
5.2.3 FU/CPS – Selectivity between fuse(s) to IEC 60269-1 (UD) and a CPS to IEC 60947-6-2 (DD).....	21
5.2.4 FU/MOR – Selectivity between fuse(s) to IEC 60269-1 (UD) and a motor overload protection relay to IEC 60947-4-1 or IEC 60947-4-2 (DD).....	21
6 Residual current devices (RCDs).....	21
6.1 General.....	21
6.2 Selectivity – RCD/RCD.....	22
6.2.1 Selectivity between RCDs in the case of earth-leakage current.....	22
6.2.2 Selectivity between RCDs in the case of earth-fault (ground-fault) current.....	23
7 Zone Selective Interlocking (ZSI).....	24
7.1 General.....	24
7.2 Operating principle.....	24
7.3 Example.....	25
8 Over-current protection relay (OCR) – Single input energizing quantity measuring relays with dependent or independent time.....	26
Annex A (informative) Examples of selectivity between over-current protection devices Examples of the grades of selectivity applicable to circuit-breakers.....	27
Annex B (informative) Standing loads – Effect of standing loads on selectivity in the overload zone.....	30
Bibliography.....	33

Figure 1 – Comparison of the operating characteristics of circuit-breakers in the overload zone	13
Figure 2 – Example of selectivity in the fault current zone with time-delay short-circuit release	14
Figure 3 – Selectivity in the overload zone between a circuit-breaker (UD) and a fuse (DD).....	16
Figure 4 – Circuit-breaker/MOR – Circuit-breaker selectivity with motor overload relay	17
Figure 5 – ICB/MOR – ICB selectivity with motor overload relay	18
Figure 6 – Fuse/circuit -breaker - Verification of selectivity between fuse and circuit-breaker for operating time in the overload zone ($t \geq 0,1$ s for the fuse).....	19
Figure 7 – FU/CB – Verification of selectivity between fuse and circuit-breaker for operating time $t < 0,1$ s	19
Figure 8 – FU/FU – Verification of selectivity between fuses for operating time $t \geq 0,1$ s	20
Figure 9 – RCD characteristics showing selectivity on earth-leakage – time-delay Type S versus non-time delay.....	23
Figure 10 – Schematic diagram of an installation designed for multiple supplies with zone selective interlocking	25
Figure 11 – Schematic diagram of mains distribution system with OCR protection	26
Figure A.1 – Circuit-breaker coordination example – 50 kA/9 kA fault levels	27
Figure A.2 – Time-current curves (examples 1 and 2)	28
Figure A.3 – Operation in the fault current zone (examples 1 and 2)	28
Figure A.4 – Circuit-breaker coordination example – 50 kA/20 kA fault levels	29
Figure B.1 – Overload and short-circuit zones.....	30
Figure B.2 – OCPDs in series	31
Table 1 – Type of selectivity and corresponding subclause number	12

INTERNATIONAL ELECTROTECHNICAL COMMISSION

**LOW-VOLTAGE SWITCHGEAR AND CONTROLGEAR –
OVER-CURRENT PROTECTIVE DEVICES –****Part 2: Selectivity under over-current conditions**

FOREWORD

- 1) The International Electrotechnical Commission (IEC) is a worldwide organization for standardization comprising all national electrotechnical committees (IEC National Committees). The object of IEC is to promote international co-operation on all questions concerning standardization in the electrical and electronic fields. To this end and in addition to other activities, IEC publishes International Standards, Technical Specifications, Technical Reports, Publicly Available Specifications (PAS) and Guides (hereafter referred to as "IEC Publication(s)"). Their preparation is entrusted to technical committees; any IEC National Committee interested in the subject dealt with may participate in this preparatory work. International, governmental and non-governmental organizations liaising with the IEC also participate in this preparation. IEC collaborates closely with the International Organization for Standardization (ISO) in accordance with conditions determined by agreement between the two organizations.
- 2) The formal decisions or agreements of IEC on technical matters express, as nearly as possible, an international consensus of opinion on the relevant subjects since each technical committee has representation from all interested IEC National Committees.
- 3) IEC Publications have the form of recommendations for international use and are accepted by IEC National Committees in that sense. While all reasonable efforts are made to ensure that the technical content of IEC Publications is accurate, IEC cannot be held responsible for the way in which they are used or for any misinterpretation by any end user.
- 4) In order to promote international uniformity, IEC National Committees undertake to apply IEC Publications transparently to the maximum extent possible in their national and regional publications. Any divergence between any IEC Publication and the corresponding national or regional publication shall be clearly indicated in the latter.
- 5) IEC provides no marking procedure to indicate its approval and cannot be rendered responsible for any equipment declared to be in conformity with an IEC Publication.
- 6) All users should ensure that they have the latest edition of this publication.
- 7) No liability shall attach to IEC or its directors, employees, servants or agents including individual experts and members of its technical committees and IEC National Committees for any personal injury, property damage or other damage of any nature whatsoever, whether direct or indirect, or for costs (including legal fees) and expenses arising out of the publication, use of, or reliance upon, this IEC Publication or any other IEC Publications.
- 8) Attention is drawn to the Normative references cited in this publication. Use of the referenced publications is indispensable for the correct application of this publication.
- 9) Attention is drawn to the possibility that some of the elements of this IEC Publication may be the subject of patent rights. IEC shall not be held responsible for identifying any or all such patent rights.

The main task of IEC technical committees is to prepare International Standards. However, a technical committee may propose the publication of a technical report when it has collected data of a different kind from that which is normally published as an International Standard, for example "state of the art".

IEC 61912-2, which is a technical report, has been prepared by subcommittee 17B: Low-voltage switchgear and controlgear, of IEC technical committee 17: Switchgear and controlgear.

The text of this technical report is based on the following documents:

Enquiry draft	Report on voting
17B/1606/DTR	17B/1666/RVC

Full information on the voting for the approval of this technical report can be found in the report on voting indicated in the above table.

This publication has been drafted in accordance with the ISO/IEC Directives, Part 2.

A list of all parts of IEC 61912 series, published under the general title *Low-voltage switchgear and controlgear – Over-current protective devices*, can be found on the IEC website.

The committee has decided that the contents of this publication will remain unchanged until the maintenance result date indicated on the IEC web site under "<http://webstore.iec.ch>" in the data related to the specific publication. At this date, the publication will be

- reconfirmed,
- withdrawn,
- replaced by a revised edition, or
- amended.

A bilingual version of this publication may be issued at a later date.

INTRODUCTION

Low-voltage equipment standards IEC 60947, IEC 60269, IEC 60898-1 and IEC 61009-1 currently include operating characteristics for over-current protective devices, defined in terms of the ability of the equipment to operate at levels of over-current up to their maximum short-circuit current ratings. In practice, the installation of such devices in series requires consideration of the relationship between the device characteristics to achieve the optimum in supply availability in the event of an over-current causing operation of any device. The ability of an over-current device to perform selectively in combination with other such devices needs to be fully understood by the circuit designer to avoid leaving a circuit vulnerable to unnecessary loss of supply, particularly where critical supplies are concerned. It is also useful to take full advantage of the capability of devices and systems to avoid over-engineering, with the consequent unnecessary additional cost. Selectivity over the whole range of fault current up to the prospective fault current at the point of installation is not always possible or necessary. A more economic solution may be found in many cases by accepting a limited selectivity, particularly taking into account the low probability of a high short-circuit fault current.

Where a short-circuit protective device is used to provide back-up protection to a downstream device, guidance on the application is provided in IEC/TR 61912-1.

LOW-VOLTAGE SWITCHGEAR AND CONTROLGEAR – OVER-CURRENT PROTECTIVE DEVICES –

Part 2: Selectivity under over-current conditions

1 Scope

This technical report, which serves as an application guide for the determination of selectivity between over-current protective devices of low-voltage switchgear and controlgear, summarises the definitions of the terminology and provides examples of application.

The following standards for devices are considered in this technical report:

- IEC 60255-3; IEC 60255-6; IEC 60255-8, IEC 60255-12
- IEC 60269-1, IEC 60269-2, IEC 60269-3; IEC 60269-4;
- IEC 60898-1;
- IEC 60947 series;
- IEC 61008-1;
- IEC 61009-1.

This report does not deal with other forms of protection, such as power-reversal protection, directional protection and arc-protection systems.

2 Normative references

The following referenced documents are indispensable for the application of this document. For dated references, only the edition cited applies. For undated references, the latest edition of the referenced document (including any amendments) applies.

IEC 60255 (all parts), *Electrical relays*

IEC 60269-1, *Low-voltage fuses – Part 1: General requirements*

IEC 60269-2, *Low-voltage fuses – Part 2: Supplementary requirements for fuses for use by authorized persons (fuses mainly for industrial application) – Examples of standardized systems of fuses A to I*

IEC 60269-3, *Low-voltage fuses – Part 3: Supplementary requirements for fuses for use by unskilled persons (fuses mainly for household and similar applications)*

IEC 60269-4, *Low-voltage fuses – Part 4: Supplementary requirements for fuse-links for the protection of semiconductor devices*

IEC 60898-1, *Electrical accessories – Circuit-breakers for over-current protection for household and similar installations – Part 1: Circuit-breakers for a.c. operation*

IEC 60947-2, *Low-voltage switchgear and controlgear – Part 2: Circuit-breakers*

IEC 60947-4-1, *Low-voltage switchgear and controlgear – Part 4-1: Contactors and motor-starters – Electromechanical contactors and motor-starters*

IEC 60947-4-2, *Low-voltage switchgear and controlgear – Part 4-2: Contactors and motor-starters – AC semiconductor motor controllers and starters*

IEC 60947-6-2, *Low-voltage switchgear and controlgear – Part 6-2: Multiple function equipment – Control and protective switching devices (or equipment) (CPS)*

IEC 61008-1, *Residual current operated circuit-breakers without integral over-current protection for household and similar uses (RCCBs) – Part 1: General rules*

IEC 61009-1, *Residual current operated circuit-breakers with integral over-current protection for household and similar uses (RCBOs) – Part 1: General rules*

IEC/TR 61459, *Coordination between fuses and contactors/motor-starters – Application guide*

IEC/TR 61818, *Application guide for low-voltage fuses*

IEC/TR 61912-1, *Low-voltage switchgear and controlgear – Overcurrent protective devices – Part 1: Application of short-circuit ratings*

3 Terms, definitions and abbreviated terms

For the purposes of this document, the following terms, definitions and abbreviated terms apply.

3.1 Alphabetical index of terms

	Reference
B	
back-up protection	3.2.6
C	
coordination of over-current protective devices	3.2.1
D	
downstream device (DD).....	3.2.8
F	
fault current zone (of over-current).....	3.2.10
O	
over-current discrimination.....	3.2.2
over-current protective device (OCPD).....	3.2.5
overload zone (of over-current).....	3.2.9
S	
selectivity of protection	3.2.3
selectivity limit current	3.2.4
U	
upstream device (UD)	3.2.7

3.2 Terms and definitions

3.2.1

coordination of over-current protective devices

coordination of two or more over-current protective devices in series to ensure over-current discrimination (selectivity) and/or back-up protection

NOTE This report deals with selectivity. Guidance on back-up protection is given in IEC/TR 61912-1.

3.2.2

over-current discrimination

coordination of the operating characteristics of two or more over-current protective devices such that, on the incidence of over-currents within stated limits, the device intended to operate within these limits does so, while the other(s) does (do) not

NOTE Distinction is made between series discrimination, involving different over-current protective devices passing substantially the same over-current, and network discrimination involving identical protective devices passing different proportions of the over-current.

[IEV 441-17-15]

3.2.3

selectivity of protection

ability of a protection to identify the faulty section and/or phase(s) of a power system

[IEV 448-11-06]

NOTE Whereas the terms “selectivity” and “discrimination” have a similar meaning according to the IEV definitions, this report prefers and uses the term “selectivity” to express the ability of one over-current device to operate in preference to another over-current device in series, over a given range of over-current. The effect of standing load current on selectivity in the overload zone is also considered.

3.2.4

selectivity limit current

current coordinate (I_s) of the intersection between the maximum break time-current characteristic of the downstream over-current protective device and the pre-arcing (for fuses) or tripping (for circuit-breakers) time-current characteristic of the upstream over-current protective device

[IEV 442-05-60 modified]

NOTE 1 In the case of a combination of circuit-breakers without intentional time-delay, in the short-circuit zone the selectivity limit-current is not a simple function of time and must be established from test data.

NOTE 2 In the case of a combination of fuses, in the short-circuit zone the selectivity limit-current is a function of energy let-through I^2t .

3.2.5

over-current protective device

OCPD

device provided to interrupt an electric circuit in the case of the current in the circuit exceeding a predetermined value for a specified duration

[IEV 826-14-14 modified]

NOTE The term OCPD includes the use of an over-current protective relay in combination with a separate switching device.

3.2.6

back-up protection

over-current coordination of two over-current protective devices in series where the protective device, generally but not necessarily on the supply side, effects the over-current protection with or without the assistance of the other protective device and prevents any excessive stress on the latter

[IEC 60947-1, definition 2.5.24]

NOTE When referred to particular devices in combination, back-up protection is sometimes known as "series rating".

3.2.7

upstream device

UD

in considering selectivity between two OCPDs, the OCPD connected in the circuit nearest to the source of supply

3.2.8

downstream device

DD

in considering selectivity between two OCPDs, the OCPD connected in the circuit immediately following the upstream device, on the load side

3.2.9

overload zone (of over-current)

range of current, exceeding the rated current of the OCPD, produced by the circuit loading in the absence of a fault in the circuit

NOTE 1 The overload zone operation of the OCPD is in the range from a few seconds, up to four hours, following an inverse time/current characteristic.

NOTE 2 In the case of a distribution circuit, the overload zone is not strictly defined since it depends on the capability of the load to draw excessive current. It may be defined by the characteristics of the OCPD as follows:

- in the case of a circuit-breaker, this is the point when the tripping characteristic changes from inverse time dependent to virtually instantaneous, at which level the operation will be in less than 0,2 s. Typically, this occurs in the region of 10 times the nominal full-load current, dependent on the setting.

MCBs to IEC 60898-1 have defined limits of instantaneous tripping given, in Table 7 of the standard, as three types B, C and D;

- in the case of a fuse, the overload zone may be considered as values of over-current that result in operation in more than 0,1 s, typically below 10-20 times rated current.

NOTE 3 In the case of a circuit supplying an individual motor, the overload zone is limited to the stalled current of the motor, typically 6-15 times motor full-load current (I_e), exceptionally higher values are found.

NOTE 4 Within the overload zone, transitory conditions may occur, for example transformer inrush currents, of only a few milliseconds duration.

3.2.10

fault current zone (of over-current)

range of current exceeding the overload current, produced by a fault in the circuit

NOTE 1 In the fault current zone, operation of a circuit-breaker as OCPD is typically in the range from a few milliseconds (instantaneous), up to three seconds with a definite short-time delay function.

Below 50 ms the time/current characteristic is no longer useful. Reference should be made to current limitation and/or energy let-through characteristics.

NOTE 2 In the case of a fuse, the fault current zone may be considered as values of over-current that result in operation in less than 0,1 s.

The time current characteristic of a fuse uses the pre-arcing time, i.e. the time after which the fuse will operate. Above 0,1 s pre-arcing time, on an a.c. supply, the arcing time of the fuse is not considered significant. However below 0,1 s pre-arcing time, the arcing time is a significant portion of the total time and hence the time/current characteristic is no longer useful and the I^2t characteristic is used.

NOTE 3 The fault current zone is also referred to as the short-circuit zone.

3.3 Abbreviated terms

ACB Air circuit-breaker

CB	Circuit-breaker to IEC 60947-2 (includes ACB, MCCB and ICB)
CBR	Residual current circuit-breaker to IEC 60947-2, Annex B
CPS	Control and protective switching device to IEC 60947-6-2
DD	Downstream device
FU	Fuse to IEC 60269-1, IEC 60269-2, IEC 60269-3 or IEC 60269-4
ICB	Instantaneous trip (only) circuit-breaker to Annex O of IEC 60947-2
I_{cn}	Ultimate short-circuit breaking capacity of an MCB
I_{cu}	Ultimate short-circuit breaking capacity of a CB
I_p	Prospective short-circuit current
I_s	Selectivity limit current
LV	Low voltage
MCB	Circuit-breaker to IEC 60898-1 for over-current protection in household and similar installations
MCCB	Moulded case circuit-breaker to IEC 60947-2
MOR	Motor overload relay
MRCD	Modular residual current device to IEC 60947-2, Annex M
MV	Medium voltage
OCPD	Over-current protective device
OCR	Over-current relay to IEC 60255 series
RCBO	Residual current circuit-breaker to IEC 61009-1
RCD	Residual current device to IEC 61008-1, IEC 61009-1, IEC 60947-2
SCPD	Short-circuit protective device
t_d	Delay time
Tx	Transformer
UD	Upstream device
ZSI	Zone selective interlocking

4 Scope of selectivity requirements

4.1 General

Table 1 shows the range of OCPDs considered and gives a designation for each type of selectivity and the corresponding clause number of this report.

Where an OCPD is equipped with an undervoltage coil dependent on line voltage, selectivity may be affected by operation of an upstream device due to voltage drop on short-circuit. To improve selectivity any undervoltage release may need to be time-delayed.

Table 1 – Type of selectivity and corresponding subclause number

Upstream device (UD)	Downstream device (DD)				
	CB/MCB	FU	CPS	MOR	RCD
CB/MCB	5.1.1	5.1.2	5.1.3	5.1.4	
FU	5.2.1	5.2.2	5.2.3	5.2.4	
RCD					6.2

4.2 Motor protection circuit-breaker / Manual motor starter

These devices are not covered by a single IEC standard but combine the characteristics of a circuit-breaker to IEC 60947-2 and a motor overload relay to IEC 60947-4-1. For selectivity purposes with upstream devices they are treated in the same manner as circuit-breakers.

5 Selectivity determination

This clause deals with the method of determination of selectivity between two OCPDs in series at any point in a system. The complete coordination study requires the application of this methodology to all the OCPDs, from the supply to the load.

In determining selectivity limit currents the applicable tolerances on the operating characteristics need to be taken into account. In the following figures, the characteristics are shown without tolerance bands for simplicity. In using published time-current characteristics, the maximum operating time curve must be taken for the downstream device (DD) and the minimum operating time curve must be taken for the upstream device (UD).

NOTE Strictly for greater accuracy, the operating temperature of thermal overload devices should be taken into account by considering both the hot and cold characteristics. In practice, it is sufficient to compare either the two cold curves or the two hot curves to arrive at a satisfactory solution in most cases.

5.1 Circuit-breaker as UD

Characteristics of the over-current protection provided by an MCB, MCCB or ACB are as follows:

- Integral: – Thermal/magnetic
 – Electronic MCCB, ACB only
- External/remote: – Over-current protection relay in combination with an MCCB or ACB.

5.1.1 Selectivity between circuit-breakers

Methods for the determination of selectivity between circuit-breakers are given in 5.1.1.1, for the overload zone of operation, and in 5.1.1.2, for the fault current zone of operation.

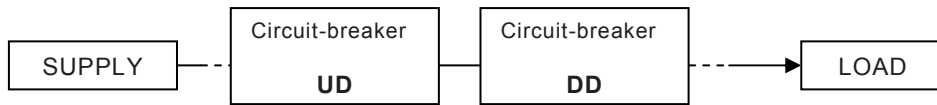

5.1.1.1 Circuit-breakers – Selectivity in the overload zone

Selectivity in the overload zone is verified by comparison of the time/current characteristics, see Figure 1a and Figure 1b (Figure 1b is applicable to MCCB and ACB only). Separation of the characteristics in both the time and current axes ensures selective operation of DD with respect to UD, in this zone. There will be a tolerance applicable to the characteristic, which should be taken into account. The manufacturer’s data should show a tolerance band or otherwise indicate the tolerance applicable, as required by the product standard.

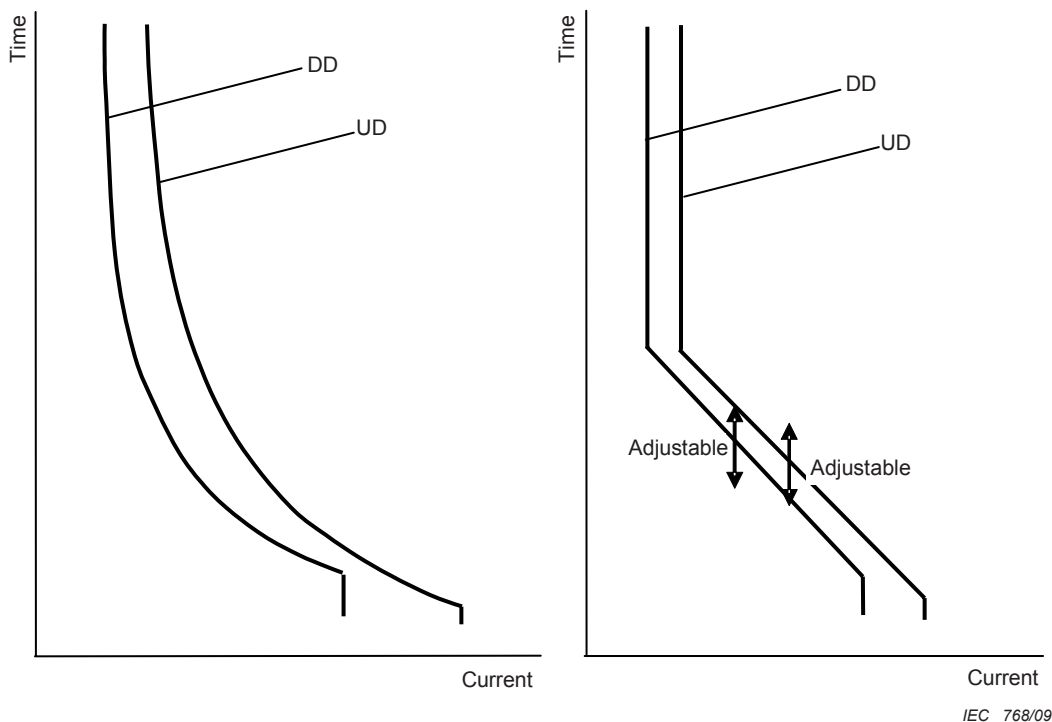

NOTE 1 The characteristics are subject to tolerances, which must be taken into account, see introduction of Clause 5.

NOTE 2 It is necessary that the current scales are in amperes (or kA) for comparison of these curves. Manufacturer’s published characteristics may be given in either amperes or multiples of rated current.

NOTE 3 A combination of thermal/magnetic and electronic characteristics is also commonly used.

Figure 1a – Comparison of thermal time/current characteristics in the overload zone

Figure 1b – Comparison of electronic time/current characteristics in the overload zone

Figure 1 – Comparison of the operating characteristics of circuit-breakers in the overload zone

5.1.1.2 Circuit-breakers – Selectivity in the fault current zone

Selectivity between circuit-breakers is elaborated in the product standards IEC 60947-2, Annex A and IEC 60898-1, Annex D, specifying the tests, where applicable, which show

determination of selectivity in the fault-current zone. The methods applicable are described in 5.1.1.2.1 and 5.1.1.2.2.

NOTE Due to their basic construction MCBs to IEC 60898-1 are generally highly selective against MCCBs to IEC 60947-2.

5.1.1.2.1 Circuit-breakers – Selectivity determination in the fault current zone by comparison of characteristics

Determination from characteristics, of selectivity between two circuit-breakers in the fault current zone, is limited to the case where UD has a short-circuit release time-delay function provided by an electronic release (see Figure 2). Selectivity at fault currents producing instantaneous tripping of UD, for both electronic and electromagnetic releases, needs to be determined from test data provided by the manufacturer (see 5.1.1.2.2).

In the absence of specific test data in the case where the instantaneous tripping of UD depends on an electromagnetic effect, the minimum level of selectivity between two circuit-breakers in the fault current zone may be determined as follows:

- selectivity is assured up to the fault current level at which the peak current let-through of DD is less than the peak value corresponding to the instantaneous tripping level of UD.

EXAMPLE UD = 800 A MCCB; $I_{inst} = 8 - 12$ kA r.m.s. (10 kA setting ± 20 %)
 DD = 125 A MCCB.

Minimum tripping level of UD is $8 \times 1,414 = 11,3$ kA peak.

Let-through current of DD at 15 kA r.m.s. prospective, due to the current limitation of DD, is 11 kA peak, from manufacturer's data.

Therefore the system is selective to at least 15 kA r.m.s. prospective.

Note that the selectivity limit obtained by this method will err on the low side and the actual limit determined by test (see 5.1.1.2.2) will be significantly higher in most cases.

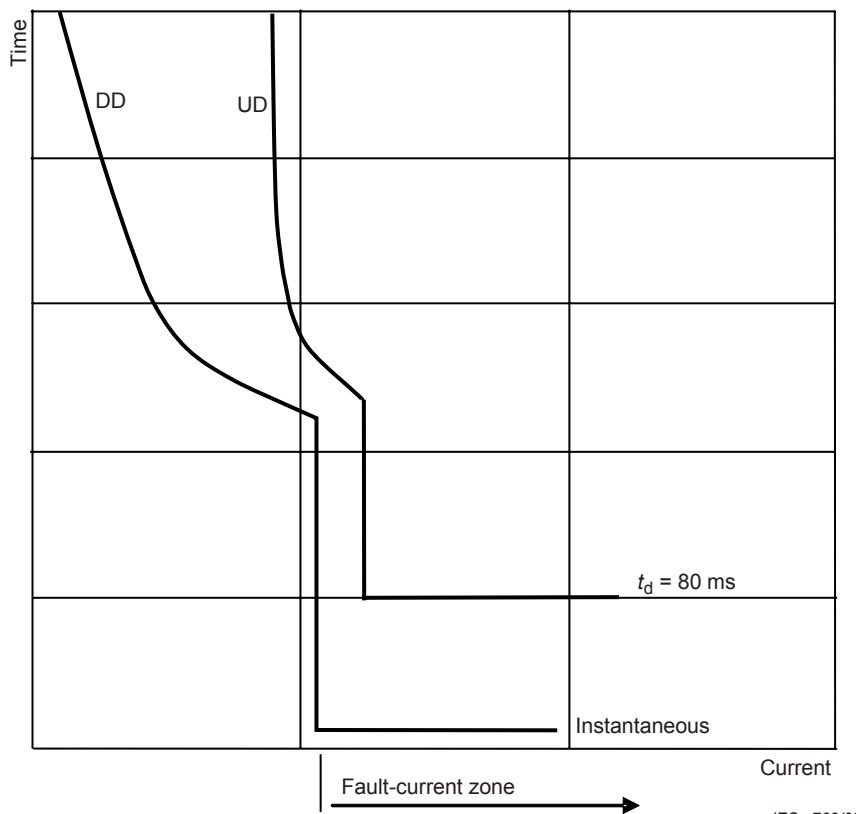

NOTE The characteristics are subject to tolerances, which must be taken into account, see introduction of Clause 5.

Figure 2 – Example of selectivity in the fault current zone with time-delay short-circuit release

5.1.1.2.2 Circuit-breakers – Selectivity determination by test in the fault current zone at fault currents producing instantaneous tripping

The selectivity limit currents, for each combination of circuit-breakers, is determined from test and the manufacturer will supply data, usually in the form of a chart. In each case selectivity may be total or partial as follows:

- a) total selectivity: this means selectivity for all over-currents up to the value of the breaking capacity, i.e. DD alone will operate (to the TRIPPED position) on over-current up to this level. In the case where UD is a current-limiting circuit-breaker, dynamic contact action can allow total selectivity to a level higher than the breaking capacity of DD (dynamic contact action means momentary opening of the contacts of UD (typically < 10 ms)). See also Note 3;
- b) partial selectivity: this means selectivity up to a value of over-current less than the breaking capacity of DD. The selectivity limit current is obtained by comparison of time/current characteristics or, in the case of instantaneous tripping of UD, from data obtained from tests and provided by the manufacturer. In the case where UD is a current-limiting circuit-breaker, dynamic contact action may occur.

Examples of the grades of selectivity applicable to circuit-breaker applications are given in Annex A.

In certain applications, the momentary contact opening may not be acceptable, in which case the selection and/or settings of the circuit-breakers may be made such that this does not occur, for example application of short-time delay to the upstream device. However, it should be appreciated that a severe voltage dip will occur during a short-circuit fault, regardless of the type of SCPD (fuse or circuit-breaker), dependent on the level of fault current and the impedance of the circuit to the location of the fault.

NOTE 1 The data for selectivity limit current in the fault current zone producing instantaneous tripping of the circuit-breaker is obtained from test data and is specific to each device type. There is no recognised method of substitution for devices of different manufacture.

NOTE 2 Proprietary software systems for determination of selectivity are available, working from time/current data supplied by individual manufacturers.

NOTE 3 Application of DD at fault current levels above the breaking capacity of DD, relying on dynamic contact action for back-up protection, cannot be used where there is significant short-circuit current contribution from inductive load(s) at the input side of DD, for example motors.

5.1.2 Selectivity between a circuit-breaker (UD) and a fuse to IEC 60269-1 (DD)

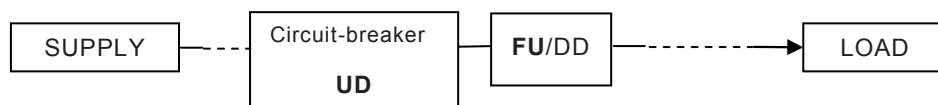

5.1.2.1 Circuit-breaker/fuse – Selectivity in the overload zone

Selectivity in the overload zone is determined by the comparison of time/current characteristics (see Figure 3).

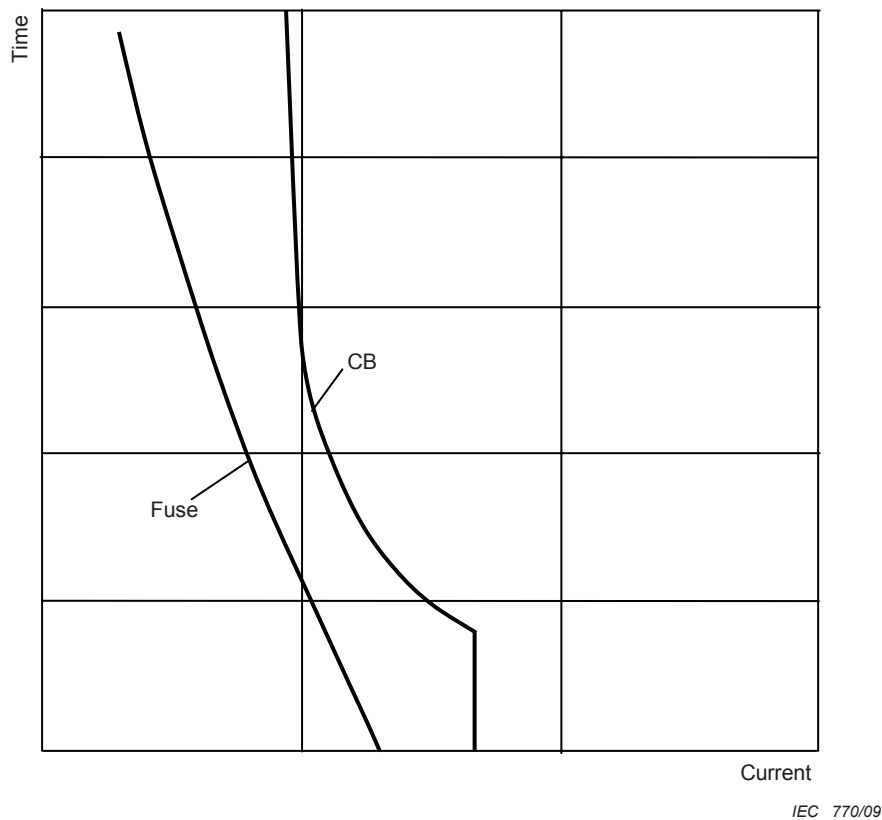

NOTE The characteristics are subject to tolerances, which must be taken into account, see introduction of Clause 5.

Figure 3 – Selectivity in the overload zone between a circuit-breaker (UD) and a fuse (DD)

5.1.2.2 Circuit- breaker/fuse – Selectivity in the fault current zone

Selectivity in the fault current zone may be determined by comparison of time/current characteristics in the case of circuit-breaker with short-circuit time-delay release. In the zone of instantaneous tripping and for a circuit-breaker without short-circuit time-delay release, the selectivity limit current must be determined from test data provided by the manufacturer.

In the absence of specific test data in the case where UD is a thermal/magnetic circuit-breaker, the minimum level of selectivity between the fuse and the circuit-breaker in the fault current zone may be determined as follows. Selectivity is assured up to the fault current level at which the peak current let-through of DD is less than the peak value corresponding to the instantaneous tripping level of UD.

Note that the selectivity limit obtained by this method will err on the low side and the actual level determined by test will be significantly higher in most cases.

5.1.3 CB/CPS – Selectivity between a circuit-breaker to IEC 60947-2 (UD) and a CPS to IEC 60947-6-2 (DD)



In general, the CPS to IEC 60947-6-2 is a final circuit device, for example a motor controller. Since it has integral over-current releases and a short-circuit breaking capacity, it is treated for selectivity purposes in the same way as a circuit-breaker (see 5.1.1).

5.1.4 Circuit-breaker/MOR – Selectivity between a circuit-breaker (UD) and a motor protection overload relay to IEC 60947-4-1 or IEC 60947-4-2 (DD)

The methods for determination of selectivity, taking into account the characteristics given in the product standards, are given in this subclause.

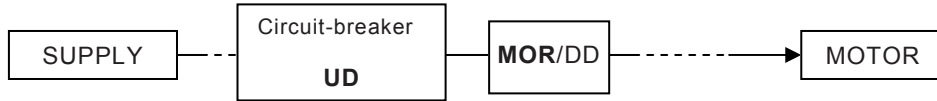

The motor protection overload relay in a motor starter or starter assembly provides overload protection to the motor and the circuit conductors. A circuit-breaker as UD is required to provide short-circuit protection to the circuit conductors and the starter itself. Coordination between the overload relay and the circuit-breaker is determined by test in accordance with IEC 60947-4-1, Clause B.4, or IEC 60947-4-2, Annex C.

Determination of the coordination either Type 1 or Type 2, ensures selectivity up to the stalled current of the motor.

A circuit-breaker, with overload and fault current functions, may be used for this purpose (see Figure 4). However, only the instantaneous tripping function is required and an ICB to IEC 60947-2, Annex O is specifically intended for this purpose (see Figure 5).

Note that circuit-breakers to IEC 60898-1 have defined overload characteristics, graded by instantaneous tripping level with specified tolerance bands. Thus selectivity in the overload zone may be established by reference to the type of characteristic B, C or D. In general, type D will be used in this application due to the inrush current of the motor.

Type B – Instantaneous tripping band = 3 to 5 I_n

Type C – Instantaneous tripping band = 5 to 10 I_n

Type D – Instantaneous tripping band = 10 to 20 I_n

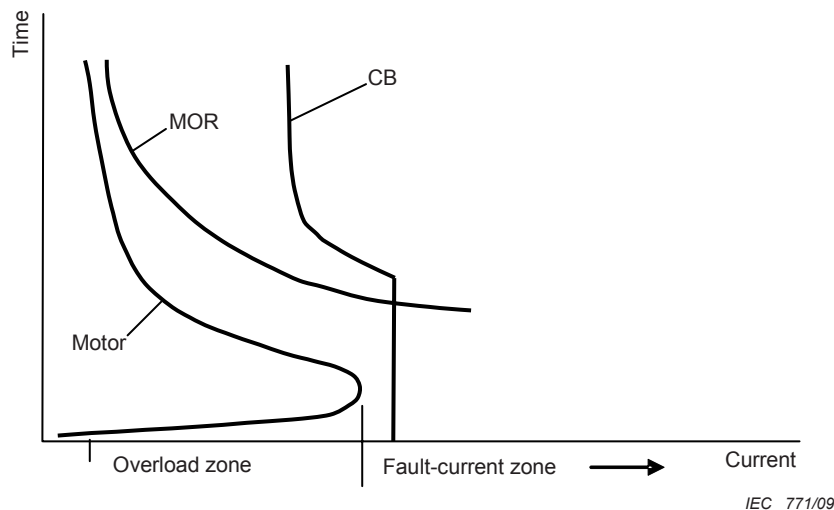

NOTE The characteristics are subject to tolerances, which must be taken into account, see introduction of Clause 5.

Figure 4 – Circuit-breaker/MOR – Circuit-breaker selectivity with motor overload relay

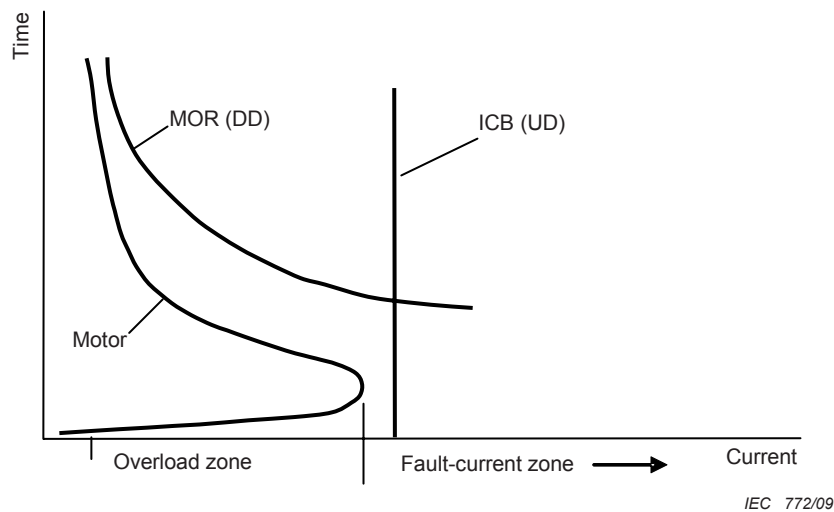

NOTE The characteristics are subject to tolerances, which must be taken into account, see introduction of Clause 5.

Figure 5 – ICB/MOR – ICB selectivity with motor overload relay

5.2 Fuse(s) to IEC 60269-1 as UD

IEC/TR 61818 provides a detailed application guide for low-voltage fuses.

IEC/TR 61459 provides a detailed application guide for coordination between fuses and contactors/motor starters.

5.2.1 Fuse/circuit-breaker – Selectivity between a fuse to IEC 60269-1 (UD) and a circuit-breaker (DD)

Methods for the determination of selectivity between a fuse and a circuit-breaker are given in 5.2.1.1, for the overload zone of operation, and in 5.2.1.2, for the fault current zone of operation.

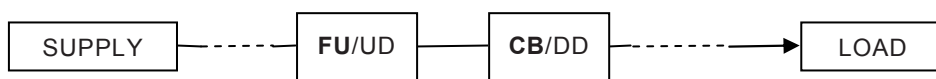

Installations are generally either circuit-breaker based or fuse based, except at the appliance level, however this particular case does arise where the fuse(s) is(are) used as back-up protection for a circuit-breaker at exceptionally high prospective fault levels.

5.2.1.1 Fuse/circuit-breaker – Selectivity in the overload zone

Selectivity in the overload zone (see 3.11) is determined by the comparison of time/current characteristics (see Figure 6).

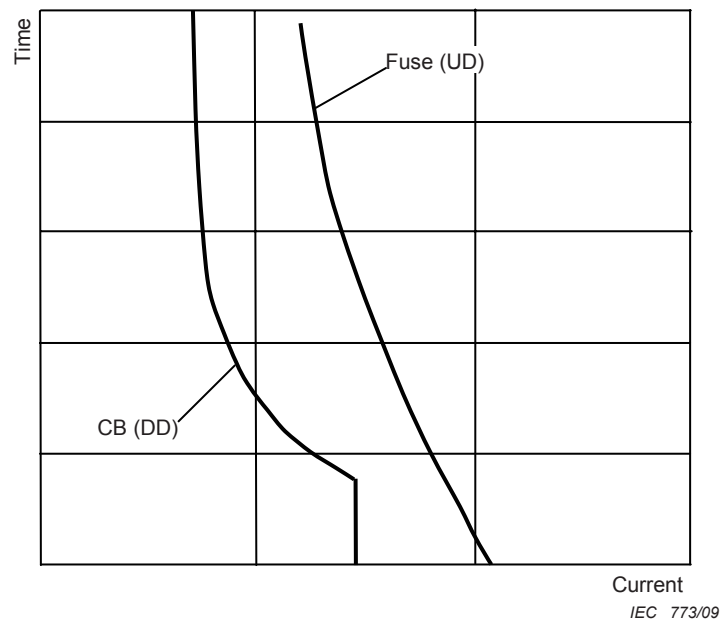

NOTE The characteristics are subject to tolerances, which must be taken into account, see introduction of Clause 5.

Figure 6 – Fuse/circuit-breaker – Verification of selectivity between fuse and circuit-breaker for operating time in the overload zone ($t \geq 0,1$ s for the fuse)

5.2.1.2 FU/CB – Selectivity in the fault current zone

Selectivity in the fault-current zone (see 3.11) is determined from the I^2t characteristics. The selectivity limit current is the value at which let-through I^2t of the circuit-breaker exceeds the pre-arcing I^2t of the fuse (see Figure 7). In the absence of an actual curve the manufacturer’s quoted I^2t pre-arc value for the fuse is taken.

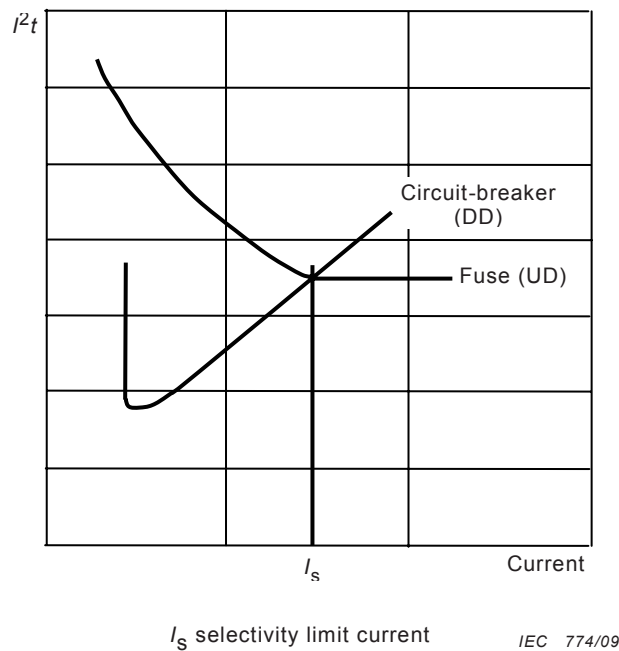

Figure 7 – FU/CB – Verification of selectivity between fuse and circuit-breaker for operating time $t < 0,1$ s

Licensed copy: Lee Shau Kee Library, HKUST, Version correct as of 03/01/2015, (c) The British Standards Institution 2013

NOTE The characteristics are subject to tolerances, which must be taken into account, see introduction of Clause 5.

5.2.2 FU/FU – Selectivity between fuses to IEC 60269-1 (UD and DD)

Methods for the determination of selectivity between fuses are given in 5.2.2.1, for the overload zone of operation, and in 5.2.2.2, for the fault current zone of operation.

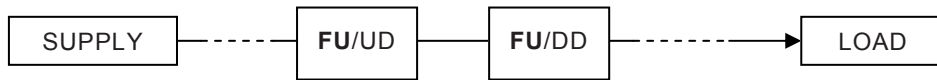

5.2.2.1 FU/FU – Selectivity in the overload zone

Selectivity in the overload zone (see 3.10) is determined by the comparison of time/current characteristics (see Figure 8).

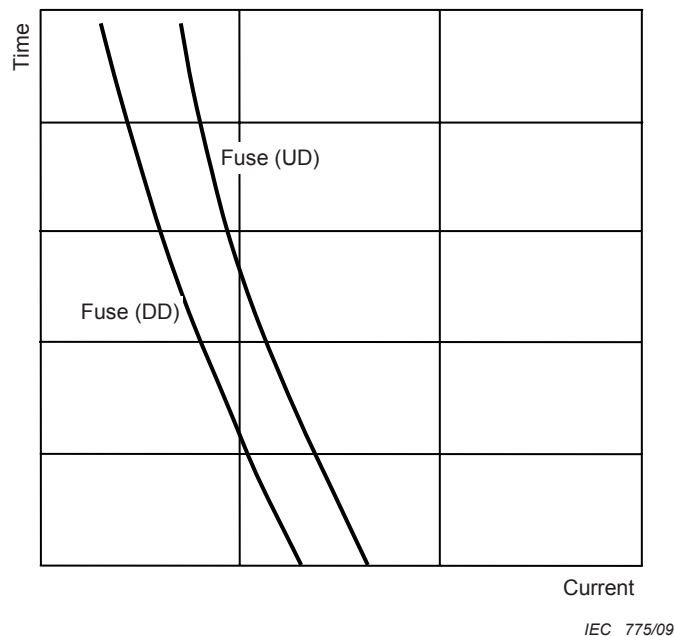

NOTE The characteristics are subject to tolerances, which must be taken into account, see introduction of Clause 5.

Figure 8 – FU/FU – Verification of selectivity between fuses for operating time $t \geq 0,1$ s

5.2.2.2 FU/FU – Selectivity in the fault current zone

Selectivity in the fault current zone (see 3.11) is determined from the I^2t characteristics. The selectivity limit current is the value at which total operating I^2t of downstream fuse FU/DD exceeds the pre-arcing I^2t of the upstream fuse FU/UD. In practice, it is advisable to allow an operating margin, for example total I^2t DD to be ≤ 80 % of I^2t pre-arc UD.

In the fault current (short-circuit) zone the I^2t of a fuse is, for the purpose of selectivity, constant and therefore the comparison may be made from tabulated figures provided by the manufacturer. Pre-arcing I^2t is independent of voltage and current in this zone. However arcing I^2t is dependent on system voltage, thus affecting the total operating value. In the case of earthed-neutral (TN) systems, the total operating I^2t of FU/DD may be taken at the phase to neutral voltage of the system.

5.2.2.3 FU/FU – Ratio of rated currents

Fuses to IEC 60269-2 of the same type (e.g. type gG) with rated currents above 16 A, will provide total selectivity if the ratio of the rated currents FU/UD to FU/DD is 1,6:1 or greater.

5.2.3 FU/CPS – Selectivity between fuse(s) to IEC 60269-1 (UD) and a CPS to IEC 60947-6-2 (DD)

The methods for determination of selectivity, taking into account the characteristics given in the product standards, are given in this clause.



In general, the CPS to IEC 60947-6-2 is a final circuit device, for example a motor controller. Since it has integral over-current releases and a short-circuit breaking capacity, it is treated for selectivity purposes in the same way as a circuit-breaker (see 5.2.1).

5.2.4 FU/MOR – Selectivity between fuse(s) to IEC 60269-1 (UD) and a motor overload protection relay to IEC 60947-4-1 or IEC 60947-4-2 (DD)

The methods for determination of selectivity, taking into account the characteristics given in the product standards, are given in this clause.



The motor protection overload relay in a motor starter or starter assembly provides overload protection to the motor and the circuit conductors. A fuse as UD is required to provide short-circuit protection to the circuit conductors and the starter itself. Selectivity between the overload relay and the fuse is determined by test in accordance with IEC 60947-4-1, Clause B.4 (coordination at the crossover current between the starter and the SCPD), or IEC 60947-4-2, Annex C (discrimination between overload protective device and SCPDs). Fuses of class gG according to IEC 60269-1 may be used for this purpose. However since only protection in the fault current (short-circuit) zone is required, fuses specifically intended for this purpose are available. Fuses types gM, gD and aM to IEC 60269-2 are fuses of reduced dimensions which may be used in motor circuits. Types gM and gD are time-delayed in the overload zone and type aM operates in the fault-current zone only, in each case enhancing the ability to withstand motor inrush currents.

In the case of a semiconductor motor starter to IEC 60947-4-2, semiconductor fuses to IEC 60269-4 are required where Type 2 coordination is specified.

Determination of the coordination according to Clause B.4 of IEC 60947-4-1, either Type 1 or Type 2, ensures selectivity up to the stalled current of the motor.

6 Residual current devices (RCDs)

6.1 General

Specific product requirements are given in IEC 61008-1, IEC 61009-1 and IEC 60947-2, Annex B and Annex M.

This document is in line with the prescription contained in IEC 62350/TR: Guidance on the correct use of RCDs.

The residual current function of an RCD operates as a protective device on currents to earth only.

The term “residual current” is used to indicate that the device detects any current difference between the line and neutral currents in a single-phase circuit; the balance or residual is the current to earth. In a three-phase circuit the device detects any resultant current from the vector-sum of the currents in the main poles. In both cases, these conditions only occur when current returns from the load side of the RCD via the earth path to the supply.

NOTE An RCD may also be referred to as an earth-leakage device.

The residual current function may be combined with overload and/or short-circuit protection in the same device or separately in the system.

In a TN-S system or IT-system (2nd fault and interconnected PE conductor) insulation faults may cause high currents, the fault current will be detected by both the RCD and the over-current protection system. In this case, the coordination has to be studied taking into account the characteristics of all the devices involved including the need for back-up protection.

An RCD will have a rated current (I_n) for the main circuit and a rated residual operating current ($I_{\Delta n}$). The rated residual operating current ($I_{\Delta n}$) may be fixed or adjustable, instantaneous or time-delayed.

6.2 Selectivity – RCD/RCD

Two levels of residual current are considered:

- earth leakage current – defined as current flowing to earth in the absence of any fault. The values of this current may be in the order of a few milliamperes;
- earth fault current – defined as current flowing to earth in case of a fault, i.e. an insulation failure between a live conductor and earth.



6.2.1 Selectivity between RCDs in the case of earth-leakage current

Instantaneous (non-time delayed) RCDs in series will have very limited selectivity, since any leakage current above $I_{\Delta n}$ of RCD/UD may cause both RCDs to operate. Therefore, RCD/UD needs to be of the time-delayed type (e.g. Type S) to achieve a measure of selectivity (see Figure 9). In practice, the ratio of $I_{\Delta n}$ of RCD/UD to $I_{\Delta n}$ of RCD/DD would be at least 3:1 and the delay time of RCD/UD should be greater than the total operating time of any DD in the circuit.

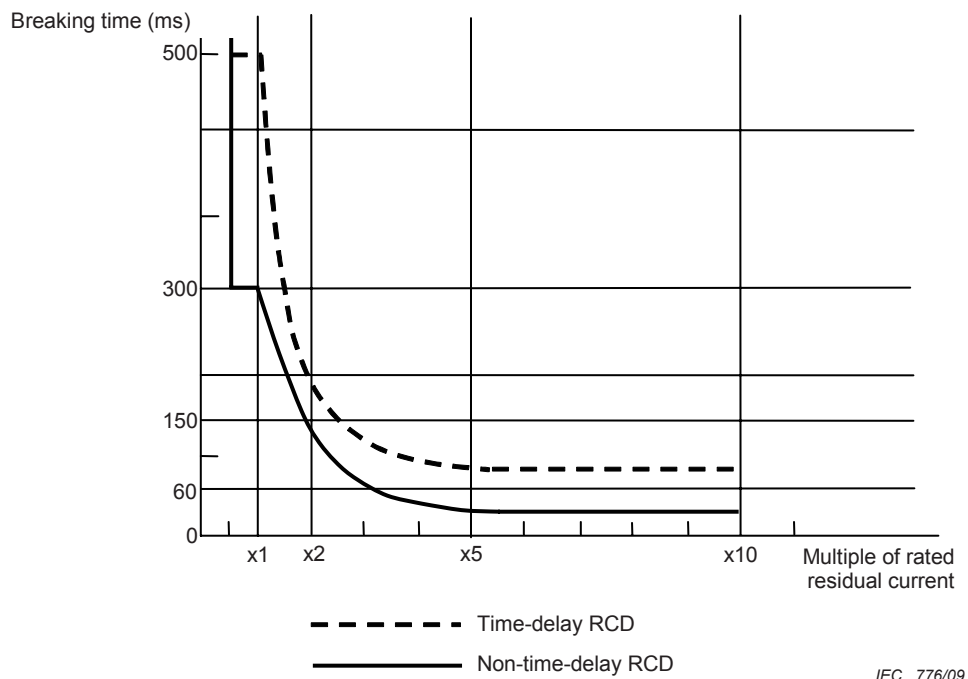

Figure 9 – RCD characteristics showing selectivity on earth-leakage – Time-delay Type S versus non-time delay

In general, a non-time delayed RCD is used as a final circuit device. An RCD with $I_{\Delta n}$ of 30 mA or less (sometimes referred to as a high-sensitivity RCD) is frequently used for additional protection against electric shock (basic protection) and in this case must be of the non-time-delayed type. Where an RCD has an adjustable range of $I_{\Delta n}$ settings and time-delay settings, for $I_{\Delta n}$ settings of 30 mA and below the time-delay must default automatically to instantaneous.

A Type S RCD is a particular type of time-delayed RCD, marked with the symbol:



This has a defined characteristic according to IEC 61008-1, IEC 61009-1 and IEC 60947-2, Annex B and Annex M, designed to be selective against a non-time-delayed RCD to those standards. The characteristic is shown in Figure 9.

Selectivity of an RCD against an SCPD:

At the levels of current involved, an RCD rated to protect against earth-leakage will always be selective against an SCPD upstream, in the case of an unwanted level of earth-leakage current.

6.2.2 Selectivity between RCDs in the case of earth-fault (ground-fault) current

Earth-fault currents will, in general, be at least an order of magnitude higher than earth-leakage currents, i.e. tens, hundreds or thousands of amperes.

Selectivity between RCDs in series is obtained in the same way as for earth-leakage currents (see 7.2.1), however at the higher currents the co-ordination with the upstream SCPD needs to be considered. In all cases selectivity is based on time-grading of time-delay type RCDs.

IEC 776/09

In the case of an RCD with integral over-current protection (RCBO to IEC 61009-1, CBR to IEC 60947-2) coordination of the functions is automatically taken care of up to the rated short-circuit capacity and no upstream SCPD is necessary.

Since RCDs in series may have limited selectivity due to circuit constraints on multiple time-grading, zone interlocking may be the preferred option (see Clause 7).

7 Zone selective interlocking (ZSI)

7.1 General

The term zone selective interlocking (ZSI) is used to describe a method of controlling circuit-breakers in order to provide selectivity with very short delay times, irrespective of the number of grading levels (zones) and the location of the fault in the distribution system. It will be necessary to install separate ZSI units at each affected circuit-breaker. The ZSI unit may be integral to the circuit-breaker or a separate unit. Interlocking may be applied to faults between phases or earth-faults or both.

7.2 Operating principle

If ZSI is used in several grading levels, each circuit-breaker affected by a short-circuit current (i.e. upstream of the fault) interrogates the circuit-breakers directly downstream of it to ascertain whether the short-circuit current is present in the next level below. The delay setting t_{zsi} is adjusted at each breaker to ensure that the downstream breaker, directly upstream of the fault, has time to interrupt the fault current. The advantages of ZSI increase with a higher number of grading levels, since time-based selectivity can result in unacceptably long delays at the supply end of the system.

7.3 Example

The operation of ZSI is best illustrated by example, see Figure 10.

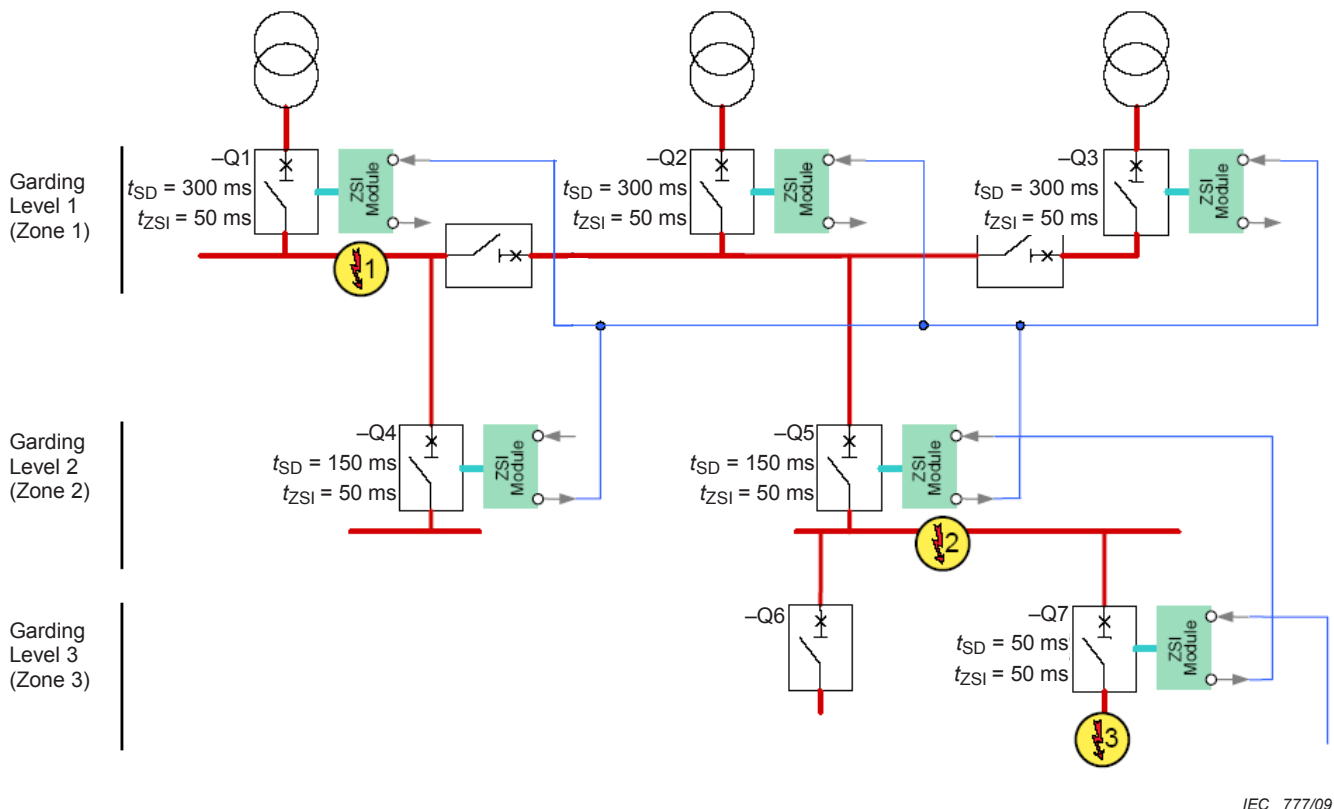

IEC 777/09

Figure 10 – Schematic diagram of an installation designed for multiple supplies with zone selective interlocking

Example A – Short-circuit at position 3:

Circuit-breakers -Q1, -Q2, -Q3, -Q5, and -Q7 register a short-circuit. -Q7 blocks -Q5 by means of the ZSI signal and, in consequence, -Q1, -Q2, and -Q3 too, so that they do not trip for $t_{ZSI} = 50$ ms. Since -Q7 does not receive a blocking signal from a subordinate circuit-breaker, -Q7 itself is responsible for interrupting the short-circuit as quickly as possible.

As an additional feature in the event of a problem with breaker Q7 (e.g. because -Q7 is no longer operational) then -Q5, as a back-up, trips after its short time delay setting, $t_{SD} = 150$ ms.

Example B – Short-circuit at position 2:

Circuit-breakers -Q1, -Q2, -Q3, and -Q5 register a short-circuit; -Q7 does not. For this reason, -Q5 does not receive a blocking signal from -Q7, but provides a blocking signal to -Q1, -Q2, and -Q3. This information tells -Q5, that it is the closest breaker upstream of the short-circuit and -Q5 trips, with a delay of $t_{ZSI} = 50$ ms instead of with a delay of $t_{SD} = 150$ ms. Clearance time is reduced by 100 ms.

Example C – Short-circuit at position 1:

Only circuit-breakers -Q1, -Q2, and -Q3 register a short-circuit and they do not receive a blocking signal from any circuit-breaker at a subordinate grading level. For this reason, -Q1, -Q2, and -Q3 trip after $t_{ZSI} = 50$ ms. Time saved: 250 ms.

8 Over-current protection relay (OCR) – Single input energizing quantity measuring relays with dependent or independent time

The requirements for OCR devices are given in the IEC 60255 series.

A secure supply provides the power for the OCR, current transformers monitor the system circuit current.

The output of the relay provides the input to the electrical tripping system of a non-automatic switching device. For example operating the shunt trip of a non-automatic circuit-breaker. The I_{cw} rating of the circuit-breaker must be equal to or greater than the prospective current value at the point of installation, with a corresponding rated time to match the OCR setting. The overload characteristic of the OCR should be set to be compatible with the performance of the circuit-breaker.

The OCR and associated switching device can be used as an alternative to using a circuit-breaker with an integral protection relay. Generally, OCRs are used at the supply input in installation, for example MV and LV main switchboards (see Figure 11).

The system designer may elect to use an OCR to provide the protection, sensitivity, selectivity and communications required for the power supply system.

Manufacturers of OCRs provide detailed application instructions, together with advice on the current transformers to be used in the measurement of circuit current and their position within the system.

Selectivity between OCRs in series and between the OCR and other OCPDs, is obtained by programmable time/current characteristics within the device, in the same manner as for circuit-breakers, see 5.1.

NOTE The total operating time of the circuit-breaker associated with the OCR, must be taken into account in addition to the OCR tripping time characteristic, when determining selectivity with other devices as described in 5.1.

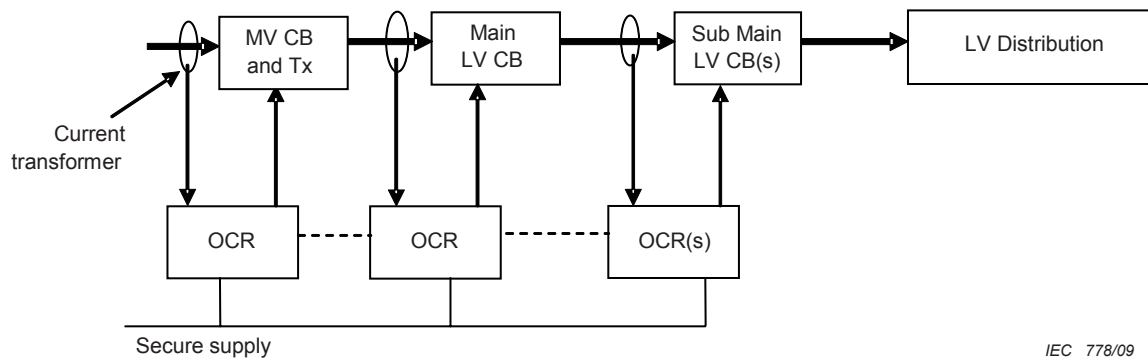

IEC 778/09

Figure 11 – Schematic diagram of mains distribution system with OCR protection

OCRs can provide a wide range of circuit protection functions, for example earth fault and restricted earth fault protection, in addition to over-current protection.

Annex A (informative)

Examples of selectivity between over-current protection devices – Examples of the grades of selectivity applicable to circuit-breakers

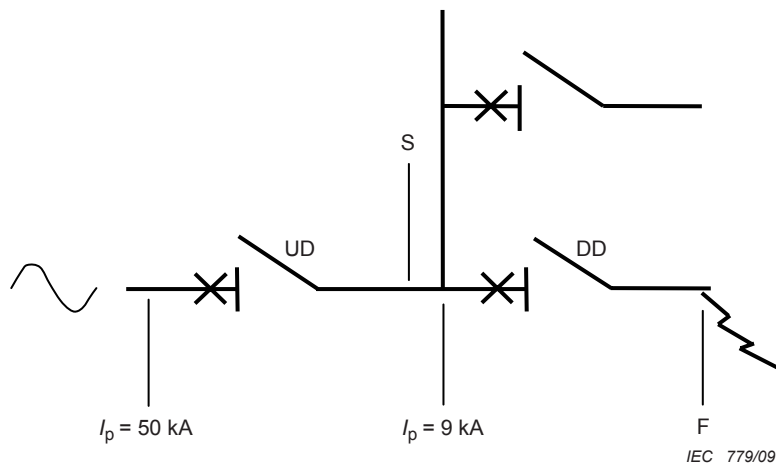

NOTE I_p is the prospective short circuit current (r.m.s.).

Figure A.1 – Circuit-breaker coordination example – 50 kA/9 kA fault levels

Example 1 – Total selectivity:

In Figure A.1: UD = MCCB $I_n = 100 \text{ A}$, $I_{cu} = 65 \text{ kA}$

DD = MCB $I_n = 32 \text{ A}$, $I_{cn} = 10 \text{ kA}$

See Figure A.2 and Figure A.3 for the characteristics of these example devices.

MCB/DD will trip for any overload or fault current at “F” and be **totally selective** against UD and there will be no interruption to the supply at “S”.

Reason: Up to the maximum available fault level, 9 kA r.m.s., the current and energy let through by DD are below the threshold for tripping of the MCCB/UD.

NOTE 1 In this example, UD is not required to provide back-up protection to DD.

Example 2 – Partial selectivity

In Figure A.1: UD = MCCB $I_n = 100 \text{ A}$, $I_{cu} = 65 \text{ kA}$

DD = MCB $I_n = 63 \text{ A}$, $I_{cn} = 10 \text{ kA}$

See Figure A.2 and Figure A.3 for the characteristics of these example devices.

MCB/DD will trip for any overload or fault current at “F”. It will be selective in the overload range and for fault currents up to 7 kA, this is the selectivity limit current for this combination, giving **partial selectivity**. At fault currents between 7 kA and 9 kA (maximum available) DD will trip and UD may also trip.

Reason: Above 7 kA r.m.s., the current and/or energy let through by DD is above the threshold for tripping of the MCCB/UD.

NOTE 2 In this example, UD is not required to provide back-up protection to DD.

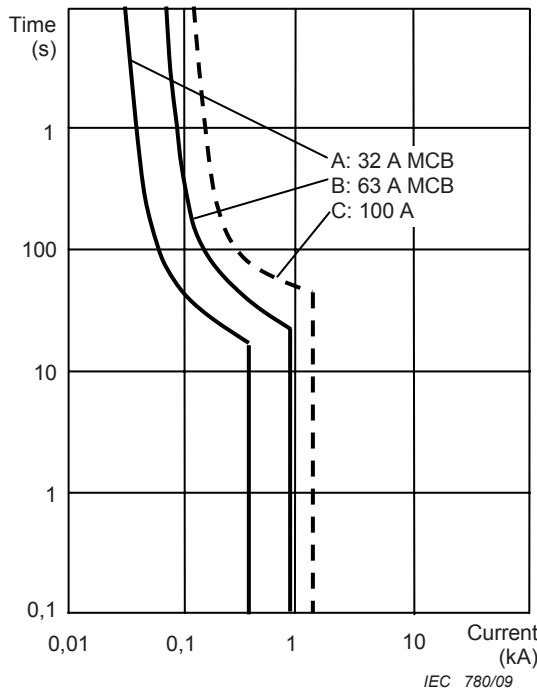

A and B totally selective with C in the overload zone

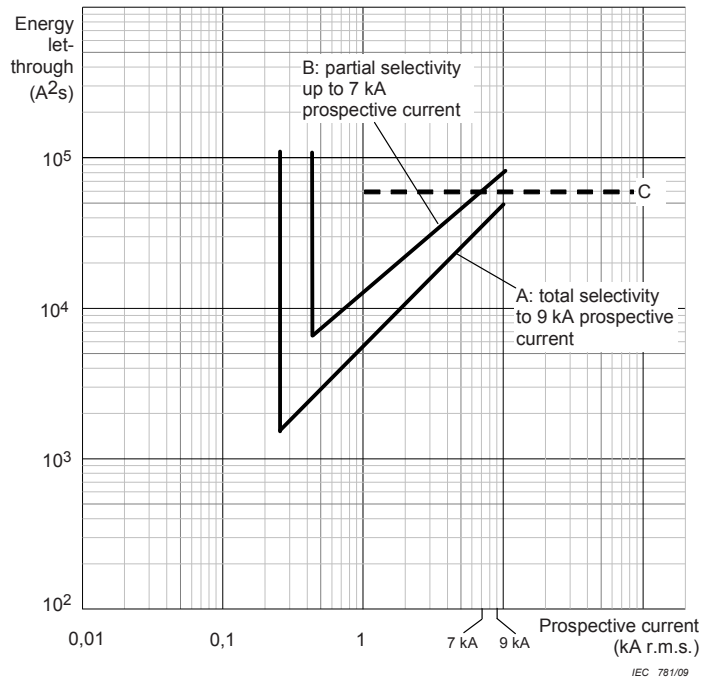

A: 32 A MCB
 B: 63 A MCB
 C: Threshold of operation of 100 A MCCB (UD)

NOTE Energy let-through is not always the sole criterion for determination of selectivity, which must be verified by test.

Figure A.2 – Time-current curves (examples 1 and 2)

Figure A.3 – Operation in the fault current zone (examples 1 and 2)

Example 3 – Total selectivity in the case of dynamic contact action

In Figure A.1: UD = MCCB* $I_n = 100$ A, $I_{cu} = 65$ kA
 DD = MCB $I_n = 63$ A, $I_{cn} = 10$ kA

* The MCCB, in this case, is of a different design to that in examples 1 and 2 above and is current-limiting.

MCB/DD will trip for any overload or fault current at “F” and UD will not trip. For fault currents above 7 kA, the contacts of UD may open momentarily (a few milliseconds). Selectivity is ensured.

NOTE 3 In this example, UD is not required to provide back-up protection to DD.

Example 4 – Total selectivity in the case of dynamic contact action for the purpose of back-up protection

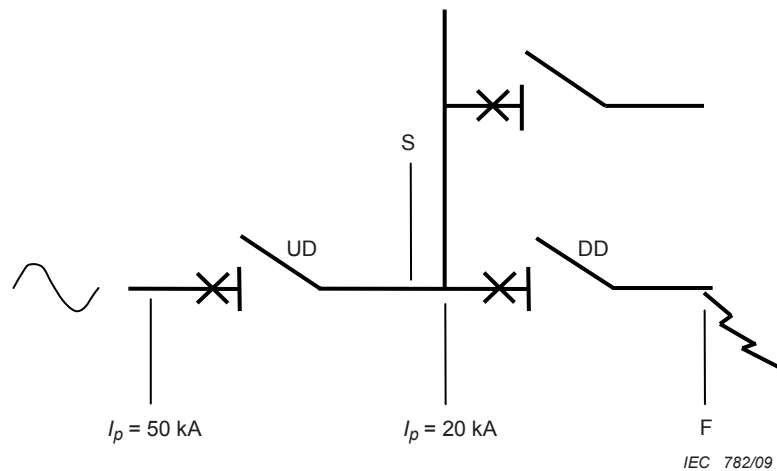

NOTE I_p is the prospective short circuit current (r.m.s.).

Figure A.4 – Circuit-breaker coordination example – 50 kA/20 kA fault levels

In Figure A.4: UD = MCCB* $I_n = 100$ A, $I_{cu} = 65$ kA

DD = MCB $I_n = 63$ A, $I_{cn} = 10$ kA

* The MCCB, in this case, is of a different design to that in examples 1 and 2 above and is current-limiting.

In this case, the fault level at “S” exceeds the rated capacity (I_{cn}) of MCB/DD and therefore MCCB/UD is selected to provide back-up protection to DD based on tests of this specific combination.

MCB/DD will trip for any overload or fault current at “F” and UD will not trip. For fault currents above 7 kA, the contacts of UD may open momentarily (a few milliseconds). This feature provides assistance in clearing the fault such that back-up protection and selectivity will be ensured for all fault currents up to 20 kA.

Annex B (informative)

Standing loads – Effect of standing loads on selectivity in the overload zone

Considering the actual currents through OCPDs in series, according to the note to 2.5.23 of IEC 60947-1 and 3.4 of this technical report (Over-current discrimination [IEV 441-17-15]) distinction is made between series discrimination involving different OCPDs passing substantially the same over-current and network discrimination involving identical OCPDs passing different proportions of the same over-current. For this reason:

- In some cases it is necessary to assess the trip times of two OCPDs carrying the same current.

This is only valid when either:

- between the two OCPDs in series there is no shunt path (branch), i.e. there is a single incoming and a single outgoing feeder, or
 - the current in the shunt paths between the two OCPDs in series is negligible in value and/or power factor by comparison with the fault current through the two OCPDs in series, for example under short-circuit conditions.
- In the case where there are several supply-side circuit-breakers on the same bus-bar or several outgoing feeders on the load side, the currents which pass through the two OCPDs could be considerably different in the overload zone.

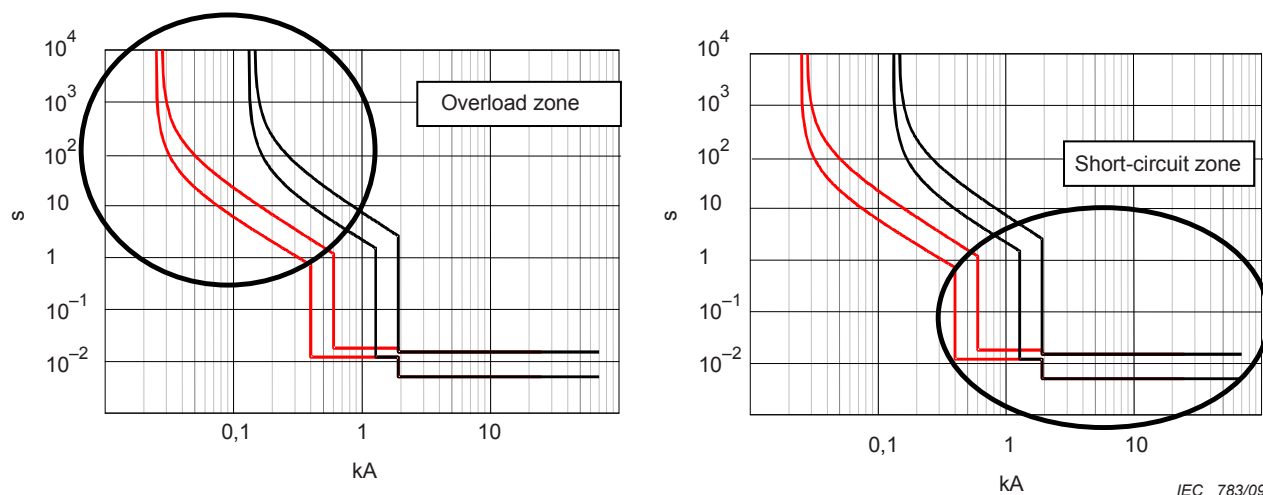

Figure B.1 – Overload and short-circuit zones

With regard to the actual currents circulating in the OCPDs, the three main cases that should be considered are as follows:

- two OCPDs in series (passing the same current), see Figure B.2a;
- a single circuit-breaker on the supply side of several load-side OCPDs (the current passing through the supply-side OCPD is higher than any one of the load-side OCPD), see Figure B.2b;
- two or more circuit-breakers on the supply side and several circuit-breakers on the load side, see Figure B.2c.

The examples given below show circuit-breakers as OCPD, the situation will be the same in the case of fuses as OCPD.

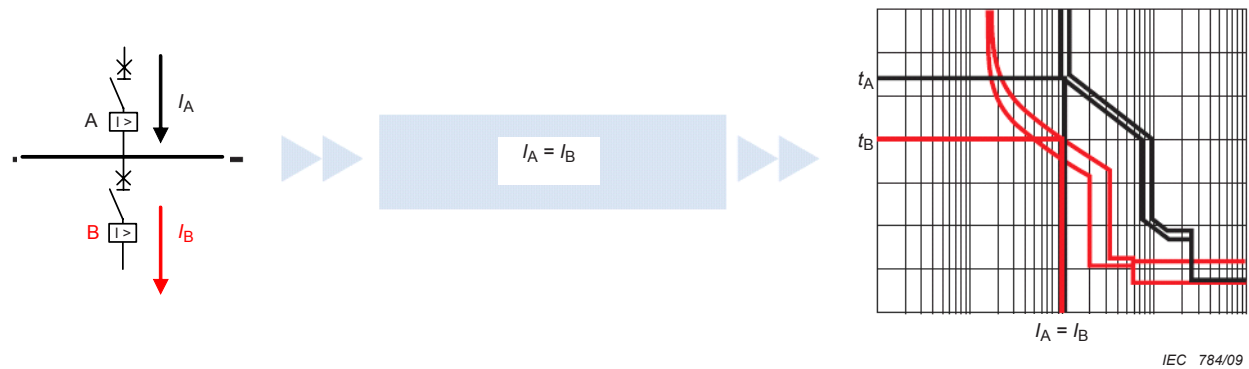

Figure B.2a – OCPDs in series, carrying the same current (no branches)

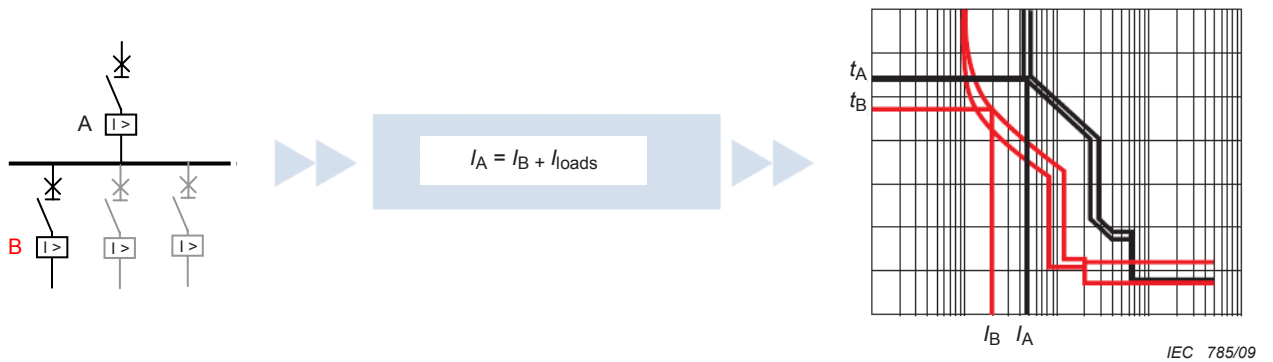

Figure B.2b – OCPDs in series, multiple loads (branches)

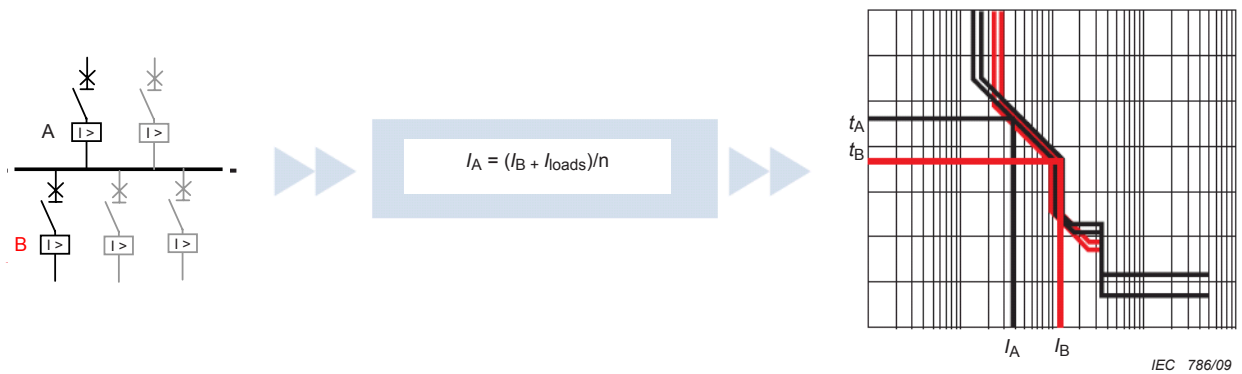

Figure B.2c – OCPDs in series, multiple loads (branches) and multiple supplies

- Key**
- I_B current passing through circuit-breaker B
 - I_A current passing through circuit-breaker A
 - I_{loads} sum (excluding B) of the load currents supplied by the circuit-breaker A under normal conditions (the actual demand and the utilization factors applied)
 - n number of equal supply circuits in parallel

NOTE These formulae do not take into account the different phase displacement of the currents or any asymmetry of the circuit; in the case of Figure B.2a and Figure B.2b, the formulae are however conservative and in the case of Figure B.2c, the formula is acceptable in practice when the multiple supplies are the same.

Figure B.2 – OCPDs in series

Bibliography

IEC 60050-441, *International Electrotechnical Vocabulary (IEV) – Chapter 441: Switchgear, controlgear and fuses*

IEC 60050-442, *International Electrotechnical Vocabulary (IEV) – Chapter 442: Electrical accessories*

IEC 60050-448, *International Electrotechnical Vocabulary (IEV) – Chapter 448: Power system protection*

IEC 60050-826, *International Electrotechnical Vocabulary (IEV) – Chapter 826: Electrical installations of buildings*

IEC 60947-1:2007, *Low-voltage switchgear and controlgear – Part 1: General rules*

IEC/TR 62350, *Guidance for the correct use of residual current-operated protective devices (RCDs) for household and similar use*

British Standards Institution (BSI)

BSI is the independent national body responsible for preparing British Standards. It presents the UK view on standards in Europe and at the international level.

It is incorporated by Royal Charter.

Revisions

British Standards are updated by amendment or revision. Users of British Standards should make sure that they possess the latest amendments or editions.

It is the constant aim of BSI to improve the quality of our products and services. We would be grateful if anyone finding an inaccuracy or ambiguity while using this British Standard would inform the Secretary of the technical committee responsible, the identity of which can be found on the inside front cover.

Tel: +44 (0)20 8996 9000 Fax: +44 (0)20 8996 7400

BSI offers members an individual updating service called PLUS which ensures that subscribers automatically receive the latest editions of standards.

Buying standards

Orders for all BSI, international and foreign standards publications should be addressed to BSI Customer Services.

Tel: +44 (0)20 8996 9001 Fax: +44 (0)20 8996 7001
Email: orders@bsigroup.com

You may also buy directly using a debit/credit card from the BSI Shop on the website www.bsigroup.com/shop

In response to orders for international standards, it is BSI policy to supply the BSI implementation of those that have been published as British Standards, unless otherwise requested.

Information on standards

BSI provides a wide range of information on national, European and international standards through its Library.

Various BSI electronic information services are also available which give details on all its products and services. Contact the Information Centre.

Tel: +44 (0)20 8996 7111

Fax: +44 (0)20 8996 7048 Email: info@bsigroup.com

Subscribing members of BSI are kept up to date with standards developments and receive substantial discounts on the purchase price of standards. For details of these and other benefits contact Membership Administration.

Tel: +44 (0)20 8996 7002 Fax: +44 (0)20 8996 7001

Email: membership@bsigroup.com

Information regarding online access to British Standards via British Standards Online can be found at www.bsigroup.com/BSOL

Further information about BSI is available on the BSI website at www.bsigroup.com

Copyright

Copyright subsists in all BSI publications. BSI also holds the copyright, in the UK, of the publications of the international standardization bodies. Except as permitted under the Copyright, Designs and Patents Act 1988 no extract may be reproduced, stored in a retrieval system or transmitted in any form or by any means – electronic, photocopying, recording or otherwise – without prior written permission from BSI.

This does not preclude the free use, in the course of implementing the standard of necessary details such as symbols, and size, type or grade designations. If these details are to be used for any other purpose than implementation then the prior written permission of BSI must be obtained. Details and advice can be obtained from the Copyright & Licensing Manager.

Tel: +44 (0)20 8996 7070 Email: copyright@bsigroup.com

BSI Group Headquarters

389 Chiswick High Road London W4 4AL UK

Tel +44 (0)20 8996 9001

Fax +44 (0)20 8996 7001

www.bsigroup.com/standards

raising standards worldwide™

