

PD IEC/TR 61547-1:2015



BSI Standards Publication

Equipment for general lighting purposes — EMC immunity requirements

Part 1: An objective voltage fluctuation immunity test method

bsi.

...making excellence a habit.™

National foreword

This Published Document is the UK implementation of IEC/TR 61547-1:2015.

The UK participation in its preparation was entrusted to Technical Committee CPL/34, Lamps and Related Equipment.

A list of organizations represented on this committee can be obtained on request to its secretary.

This publication does not purport to include all the necessary provisions of a contract. Users are responsible for its correct application.

© The British Standards Institution 2015.

Published by BSI Standards Limited 2015

ISBN 978 0 580 87892 3

ICS 29.140.20

Compliance with a British Standard cannot confer immunity from legal obligations.

This Published Document was published under the authority of the Standards Policy and Strategy Committee on 31 May 2015.

Amendments/corrigenda issued since publication

Date	Text affected
-------------	----------------------



TECHNICAL REPORT



Equipment for general lighting purposes – EMC immunity requirements – Part 1: An objective voltage fluctuation immunity test method

INTERNATIONAL
ELECTROTECHNICAL
COMMISSION

ICS 29.140.20

ISBN 978-2-8322-2649-0

Warning! Make sure that you obtained this publication from an authorized distributor.

CONTENTS

FOREWORD	4
INTRODUCTION	6
1 Scope	7
2 Normative references	7
3 Terms, definitions, abbreviations and symbols	7
3.1 Terms and definitions	7
3.2 Abbreviations	9
3.3 Symbols	9
4 General	10
5 Voltage fluctuation disturbance signal	10
5.1 General	10
5.2 Mains signal parameters	12
5.3 Disturbance signal parameters and test levels	13
6 Test setup and equipment	14
6.1 General	14
6.2 Test voltage	14
6.3 Optical test environment	15
6.4 Light sensor and amplifier	15
6.5 Signals to be measured	15
6.6 Signal processing	16
6.6.1 Anti-aliasing filter	16
6.6.2 Sampling frequency	16
6.6.3 Signal resolution	18
7 Verification procedure	18
7.1 General	18
7.2 Light flickermeter	18
7.3 Mains voltage parameters without modulation	18
7.3.1 Nominal voltage level	18
7.3.2 Mains frequency	19
7.4 Voltage fluctuation level	19
7.4.1 General	19
7.4.2 Option 1: measure the actual modulation frequencies and voltage levels	19
7.4.3 Option 2: measure P_{St} -values using a flickermeter	19
7.5 Light sensor and amplifier	19
7.6 Test environment	20
7.7 Light flicker noise	20
8 Test procedure	20
9 Conditions during testing	20
10 Evaluation of the test result	21
11 Test report	21
Annex A (informative) Specification of the light flickermeter	23
A.1 The voltage flickermeter	23
A.2 Specification of the light flickermeter	24
A.2.1 General	24
A.2.2 Block a: illuminance adapter	24

A.2.3	Block b: weighting filters	24
A.2.4	Block c: squaring multiplier, sliding mean filter and scaling	25
A.2.5	Block d: statistical analysis	25
A.3	Verification of the light flickermeter	26
Annex B (informative)	Uncertainty considerations	27
B.1	General.....	27
B.2	General symbols	27
B.3	Measurand.....	27
B.4	Influence quantities.....	27
B.5	Uncertainty budget.....	29
B.6	Reference document.....	29
Annex C (informative)	Examples of a test result.....	31
C.1	EUTs	31
C.2	Recorded signals	31
C.3	Results	34
Bibliography	36
Figure 1	– The full EMC approach for mains voltage fluctuations	11
Figure 2	– Definition of the mains test signal including a rectangular modulated voltage fluctuation (see Equation (1)).....	12
Figure 3	– Block diagram voltage-fluctuation immunity test	14
Figure 4	– Example of a recorded mains voltage fluctuation and illuminance signal of a 60 W incandescent lamp	17
Figure A.1	–Structure of the IEC 61000-4-15 flickermeter which uses voltage as input.....	23
Figure A.2	– Structure of the light flickermeter	23
Figure C.1	– EUT1: recorded signals (no mains voltage modulation).....	32
Figure C.2	– EUT1: recorded signals (with modulation).....	33
Figure C.3	– EUT2: relative illuminance: mains voltage modulation $d = 0,407\%$ at 13,5 Hz ($P_{st} = 1$).....	34
Figure C.4	– EUT3: relative illuminance: mains voltage modulation $d = 0,407\%$ at 13,5 Hz ($P_{st} = 1$).....	34
Figure C.5	– Graphical P_{st} results for three EUTs with rectangular modulation at five frequencies ($P_{st} = 1$).....	35
Table 1	– Voltage fluctuations – Test specification of voltage fluctuations applied at input a.c. power ports 230 V; 50 Hz	13
Table A.1	– Test specification of illuminance fluctuations for lightmeter classifier	26
Table B.1	– P_{st} influence quantities and their recommended tolerances.....	28
Table B.2	– Uncertainty budget of the voltage fluctuation immunity test	30
Table C.1	– Numerical results P_{st} calculations for three EUTs with and without modulation	35

INTERNATIONAL ELECTROTECHNICAL COMMISSION

EQUIPMENT FOR GENERAL LIGHTING PURPOSES – EMC IMMUNITY REQUIREMENTS –

Part 1: An objective voltage fluctuation immunity test method

FOREWORD

- 1) The International Electrotechnical Commission (IEC) is a worldwide organization for standardization comprising all national electrotechnical committees (IEC National Committees). The object of IEC is to promote international co-operation on all questions concerning standardization in the electrical and electronic fields. To this end and in addition to other activities, IEC publishes International Standards, Technical Specifications, Technical Reports, Publicly Available Specifications (PAS) and Guides (hereafter referred to as "IEC Publication(s)"). Their preparation is entrusted to technical committees; any IEC National Committee interested in the subject dealt with may participate in this preparatory work. International, governmental and non-governmental organizations liaising with the IEC also participate in this preparation. IEC collaborates closely with the International Organization for Standardization (ISO) in accordance with conditions determined by agreement between the two organizations.
- 2) The formal decisions or agreements of IEC on technical matters express, as nearly as possible, an international consensus of opinion on the relevant subjects since each technical committee has representation from all interested IEC National Committees.
- 3) IEC Publications have the form of recommendations for international use and are accepted by IEC National Committees in that sense. While all reasonable efforts are made to ensure that the technical content of IEC Publications is accurate, IEC cannot be held responsible for the way in which they are used or for any misinterpretation by any end user.
- 4) In order to promote international uniformity, IEC National Committees undertake to apply IEC Publications transparently to the maximum extent possible in their national and regional publications. Any divergence between any IEC Publication and the corresponding national or regional publication shall be clearly indicated in the latter.
- 5) IEC itself does not provide any attestation of conformity. Independent certification bodies provide conformity assessment services and, in some areas, access to IEC marks of conformity. IEC is not responsible for any services carried out by independent certification bodies.
- 6) All users should ensure that they have the latest edition of this publication.
- 7) No liability shall attach to IEC or its directors, employees, servants or agents including individual experts and members of its technical committees and IEC National Committees for any personal injury, property damage or other damage of any nature whatsoever, whether direct or indirect, or for costs (including legal fees) and expenses arising out of the publication, use of, or reliance upon, this IEC Publication or any other IEC Publications.
- 8) Attention is drawn to the Normative references cited in this publication. Use of the referenced publications is indispensable for the correct application of this publication.
- 9) Attention is drawn to the possibility that some of the elements of this IEC Publication may be the subject of patent rights. IEC shall not be held responsible for identifying any or all such patent rights.

The main task of IEC technical committees is to prepare International Standards. However, a technical committee may propose the publication of a technical report when it has collected data of a different kind from that which is normally published as an International Standard, for example "state of the art".

IEC TR 61547-1, which is a technical report, has been prepared by subcommittee 34: Lamps and related equipment.

The text of this technical report is based on the following documents:

Enquiry draft	Report on voting
34/212/DTR	34/220A/RVC

Full information on the voting for the approval of this technical report can be found in the report on voting indicated in the above table.

This publication has been drafted in accordance with the ISO/IEC Directives, Part 2.

A list of all parts in the IEC 61547 series, published under the general title *Equipment for general lighting purposes – EMC immunity requirements*, can be found on the IEC website.

The committee has decided that the contents of this publication will remain unchanged until the stability date indicated on the IEC website under "<http://webstore.iec.ch>" in the data related to the specific publication. At this date, the publication will be

- reconfirmed,
- withdrawn,
- replaced by a revised edition, or
- amended.

A bilingual version of this publication may be issued at a later date.

IMPORTANT – The 'colour inside' logo on the cover page of this publication indicates that it contains colours which are considered to be useful for the correct understanding of its contents. Users should therefore print this document using a colour printer.

INTRODUCTION

Flicker perception, and the associated IEC 61000-3-3 standard for voltage fluctuations and the flickermeter IEC 61000-4-15, is based on the 60 W incandescent lamp. As a result of the phasing out of incandescent lamps and the widespread introduction of alternative lighting equipment technologies, a new reference lamp was considered. It has been demonstrated that new lighting technologies are in general less but sometimes also more sensitive to supply voltage fluctuations than the current 60 W incandescent lamp. CIGRE working group C4.111 has assessed the impact of new lighting technologies on the existing flicker standards. Most likely, the present flicker sensitivity curve of IEC 61000-3-3 will stay as the reference, but because of the increased diversity of sensitivity of lighting equipment to voltage fluctuations, there is a future need for a voltage-fluctuation immunity test specifically for lighting equipment. In this way, the full-EMC approach (Figure 1) is introduced for flicker, i.e. limit voltage fluctuations caused by equipment connected to the grid, and in addition establish a minimum level of flicker immunity of lighting equipment against these voltage fluctuations.

This technical report provides an objective method and procedure for testing the immunity of lighting equipment against mains voltage fluctuations. With this technical report, the lighting industry can gain experience with the flicker immunity test. Results of actual tests will be reported separately in IEC TR 61547-2.

Based on the experience with this immunity test method, the adoption of a similar test in the immunity standard for lighting equipment IEC 61547 will be considered.

EQUIPMENT FOR GENERAL LIGHTING PURPOSES – EMC IMMUNITY REQUIREMENTS –

Part 1: An objective voltage fluctuation immunity test method

1 Scope

This Part of 61547, which is a Technical Report, establishes an objective method and procedure for testing the immunity performance of lighting equipment against voltage fluctuation disturbances on the a.c. power port.

The object of this Technical Report is to establish a common and objective reference for evaluating the immunity of lighting equipment in terms of illuminance flicker when subjected to mains voltage fluctuations. Temporal changes in the colour of the light (chromatic flicker) are not considered in this test.

This method and procedure can be applied to lighting equipment which is within the scope of IEC technical committee 34, such as lamps and luminaires, intended for connection to a low voltage electricity supply. Independent auxiliaries such as drivers can be tested also by application of a representative light source to that auxiliary.

The method and procedure described in this technical report are based on the IEC 61000-3-3 standard for voltage fluctuation limits and the flickermeter standard IEC 61000-4-15.

The test method described in this report applies to lighting equipment rated for 230 V a.c. and 50 Hz (for verification purposes).

NOTE The principle of the method can be applied for other nominal voltage and frequency ratings.

2 Normative references

The following documents, in whole or in part, are normatively referenced in this document and are indispensable for its application. For dated references, only the edition cited applies. For undated references, the latest edition of the referenced document (including any amendments) applies.

IEC 61000-3-3:2013, *Electromagnetic compatibility (EMC) – Part 3-3: Limits – Limitation of voltage changes, voltage fluctuations and flicker in public low-voltage supply systems, for equipment with rated current ≤ 16 A per phase and not subject to conditional connection*

IEC 61000-4-15:2010, *Electromagnetic compatibility (EMC) – Part 4-15: Testing and measurement techniques – Flickermeter – Functional and design specifications*

3 Terms, definitions, abbreviations and symbols

3.1 Terms and definitions

For the purposes of this document, the terms and definitions given in IEC 61000-3-3, IEC 61000-4-15 and the following apply.

3.1.1**flicker**

impression of unsteadiness of visual sensation induced by a light stimulus whose luminance or spectral distribution fluctuates with time

[SOURCE: IEC 60050-845:1987, 845-02-49]

3.1.2**flickermeter**

instrument designed to measure any quantity representative of flicker

[SOURCE: IEC 60050-604:1987, 604-01-28]

3.1.3**voltage flickermeter**

instrument as specified in IEC 61000-4-15 which is designed to measure any quantity representative of flicker resulting from mains voltage fluctuations

3.1.4**illuminance**

quotient of the luminous flux $d\Phi_v$ incident on an element of the surface containing the point, by the area dA of that element

Equivalent definition. Integral, taken over the hemisphere visible from the given point, of the expression $L_v \cdot \cos \theta \cdot d\Omega$ where L_v is the luminance at the given point in the various directions of the incident elementary beams of solid angle $d\Omega$, and θ is the angle between any of these beams and the normal to the surface at the given point

$$E_v = \frac{d\Phi_v}{dA} = \int_{2\pi \text{ sr}} L_v \cdot \cos \theta \cdot d\Omega$$

Note 1 to entry: Illuminance is expressed in lx or $\text{lm} \cdot \text{m}^{-2}$

[SOURCE: IEC 60050-845:1987, 845-01-38]

3.1.5**light flickermeter**

instrument designed to measure flicker resulting from temporal changes in the intensity of the light in an objective way and based on the IEC 61000-4-15 specifications

3.1.6**threshold of flicker irritability**

maximum value of a fluctuation of luminance or of spectral distribution which gives rise to a flicker tolerated without discomfort by a specified sample of the population

[SOURCE: IEC 60050-161:1990, 161-08-16]

3.1.7**short-term flicker indicator**

P_{st}
measure of flicker evaluated over a specified time interval of a relatively short duration
definition

Note 1 to entry: The duration is typically 10 min, in accordance with IEC 61000-4-15.

[SOURCE: IEC 60050-161:1990, 161-08-18]

3.2 Abbreviations

a.c.	alternating current
AM	amplitude modulation
CFL	compact fluorescent lamp
CIE	Commission Internationale de l'Éclairage
<i>cpm</i>	changes per minute
d.c.	direct current
EUT	equipment under test
EMC	electromagnetic compatibility
EMI	electromagnetic interference
Hz	hertz
IEEE	Institute of Electrical and Electronics Engineers
IEC	International Electrotechnical Commission
IEV	International Electrotechnical Vocabulary
ISO	International Organization for Standardization
I-SH	interpretation sheet
kHz	kilohertz
LED	light emitting diode
LP	low pass
ms	millisecond
rect	rectangular
rms	root mean square
TR	technical report
SSL	solid state lighting
V	voltage
W	watt

3.3 Symbols

α	multiplication factor
C_A	gain of the light amplifier
d	relative voltage change
d_E	relative change of the rectangular modulation of the illuminance
d_r	relative change of the 100 Hz-illuminance ripple
Δu	instantaneous total voltage variation after a voltage fluctuation,
ΔU	total voltage variation of the half-period rms value after a voltage fluctuation
f	mains frequency (50 Hz)
f_m	modulation frequency
m	modulation index
%	percent
pp	percentage point
P_{st}	short-term flicker indicator
P_{st}^E	P_{st} -value of the standardised illuminance waveform $E(t)$
P_{st}^{EUT}	P_{st} -value of the illuminance of an EUT measured with the light flickermeter

P_{st}^{LM}	P_{st} -value of the illuminance measured with the light flickermeter
P_{st}^V	P_{st} -value of the supply voltage measured with the voltage flickermeter
$P_{st}^{LM} _{noise}$	light flicker noise level
$P_{st}^V _{noise}$	P_{st} -noise level of the mains
s	the complex Laplace variable
\hat{u}	amplitude of the mains voltage
$u(t)$	mains voltage signal
$u_E(t)$	output voltage of the light sensor amplifier
T_m	modulation period
T_{test}	period of time over which the illuminance is measured during application of the voltage fluctuation
U	half-period rms-value

4 General

The immunity of lighting equipment to voltage fluctuations may be tested by applying specific types and levels of voltage fluctuations on the mains in accordance with the short-term flicker indicator $P_{st} = 1$ curve for the reference incandescent lamp of 60 W specified in IEC 61000-3-3. In this way, the full EMC approach is applied for flicker, i.e. voltage fluctuations caused by equipment connected to the grid are limited by the voltage fluctuation emission test of IEC 61000-3-3, while the level of flicker immunity of lighting equipment against these $P_{st} = 1$ voltage fluctuations is tested using the method and procedures specified in this technical report (see Figure 1).

During the test, the supply voltage is modulated with $P_{st} = 1$ fluctuation extracted from the threshold of flicker irritability curve and the luminous intensity variation of the lighting equipment is measured and recorded (denoted as P_{st}^V). A light flickermeter is applied to measure the value of the metric P_{st} (denoted as P_{st}^{LM} , whereas P_{st}^V would correspond to the flicker severity value measured from voltage fluctuations).

5 Voltage fluctuation disturbance signal

5.1 General

The immunity test against voltage fluctuations is carried out in accordance with the test method specified in Clause 6. The disturbances are rectangular amplitude modulations that are to be applied on the a.c. power port.

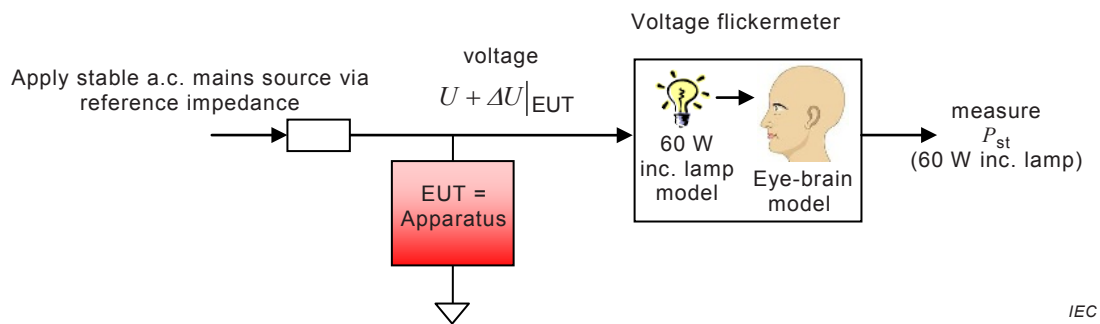

Figure 1a – Voltage fluctuation emission test IEC 61000-3-3, using the IEC voltage flickermeter IEC 61000-4-15

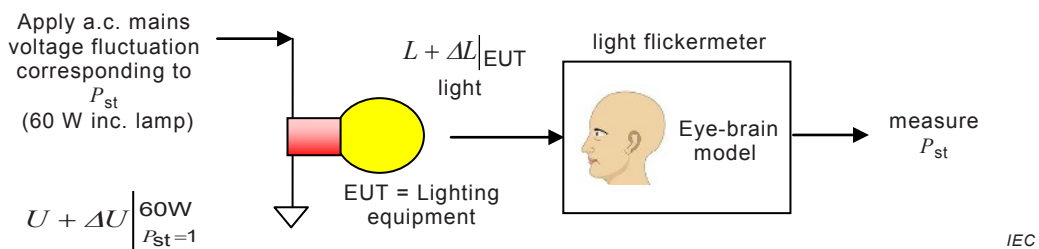

Figure 1b – Voltage fluctuation immunity test specified in this technical report

Figure 1 – The full EMC approach for mains voltage fluctuations

The mains signal is to be amplitude modulated with rectangular signals with frequencies between approximately 0,05 Hz and 40 Hz. For the rectangular modulated mains signal $u(t)$ the following equation applies:

$$u(t) = \hat{u} \cdot \sin(2\pi ft) \cdot \{1 + m \cdot \text{signum}(\sin(2\pi f_m t))\} \tag{1}$$

where

\hat{u} is the amplitude of the mains voltage;

f is the mains frequency (50 Hz);

m is the modulation index;

$\text{signum}(x)$ = the signum function, $\text{signum}(x) = 1$ for $x > 0$

$\text{signum}(x) = 0$ for $x = 0$

$\text{signum}(x) = -1$ for $x < 0$

f_m is the modulation frequency = $1/T_m$.

Furthermore the half-period rms value U of the unmodulated mains signal can be written as:

$$U = \hat{u} / \sqrt{2} \tag{2}$$

In IEC 61000-4-15, the parameter d is applied, which is the total relative voltage change:

$$d = \Delta u / \hat{u} = \Delta U / U, \tag{3}$$

for rectangular AM modulation with modulation frequencies $< f$

where

Δu is the instantaneous total voltage variation after a voltage fluctuation;

ΔU is the total voltage variation of the half-period rms value after a voltage fluctuation.

For a rectangular modulated mains signal with modulation index m the relative voltage change d is:

$$d = 2m. \quad (4)$$

The relative voltage change (or voltage fluctuation) d is often expressed as a percentage.

An example of the parameters is shown in Figure 2.

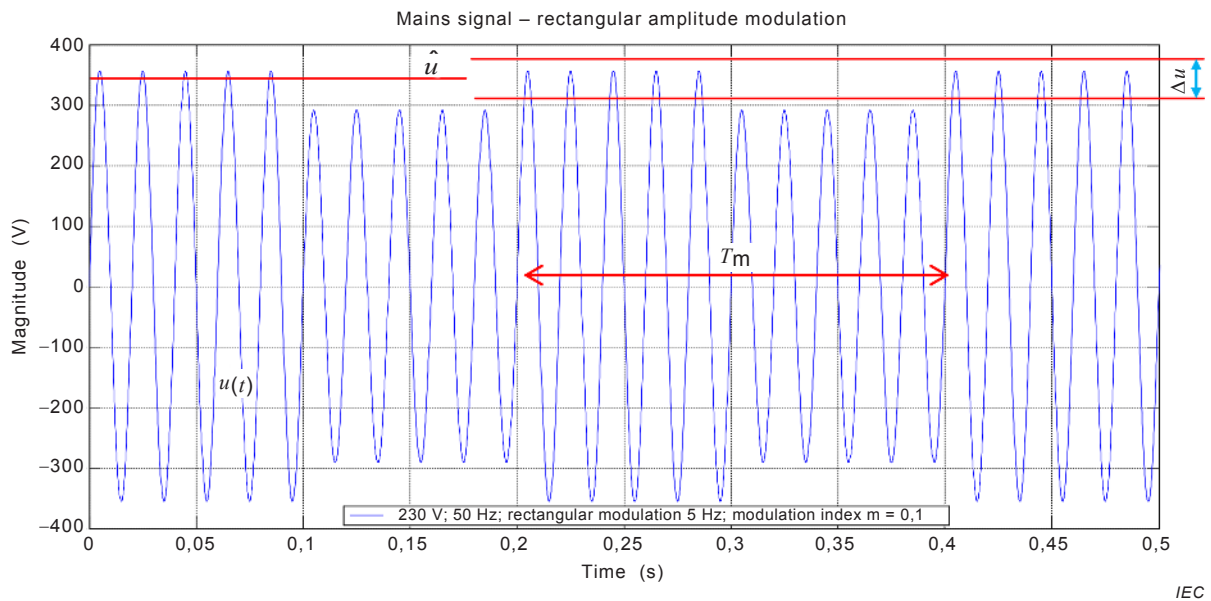

EXAMPLE Amplitude modulated mains signal (230 V; 50 Hz). Rectangular modulation; frequency 5 Hz (600 *cpm*); $T_m = 0,2$ s; modulation index $m = 0,1$ (relative voltage change $d = 20$ %).

Figure 2 – Definition of the mains test signal including a rectangular modulated voltage fluctuation (see Equation (1))

Voltage fluctuations frequencies are often expressed in terms of voltage changes per minute (*cpm*). The relation between the voltage fluctuation frequency f_m and the *cpm* (one cycle contains two changes) is:

$$f_m [\text{Hz}] = \text{cpm} [\text{changes per minute}] / 120. \quad (5)$$

5.2 Mains signal parameters

The unmodulated test voltage level U should be set and maintained at the nominal value of 230 V, with a tolerance of $\pm 0,5$ %.

The mains frequency f should be set and maintained with a tolerance of $\pm 0,5$ % of the nominal value of 50 Hz.

Residual fluctuations of the unmodulated test supply voltage during a test may give rise to P_{st} that are not exactly zero. It is recommended to keep this P_{st} -noise level below 0,2. See Clause B.5 for the impact on the uncertainty of the test.

NOTE In IEC 61000-3-3 the P_{st} -noise level is specified to be less than 0,4 which can induce an uncertainty of 8 % in the IEC 61000-4-15 measurement. However, in this test protocol there are many sources of uncertainty and that is the reason to set a more strict P_{st} -noise level tolerance.

5.3 Disturbance signal parameters and test levels

Specific test frequencies and types of modulation are specified in the IEC flickermeter standard IEC 61000-4-15 for performance verification purposes. It is recommended to use the test frequencies and the rectangular modulation given in Table 5 of IEC 61000-4-15:2010 also as test signals for voltage fluctuation immunity testing of lighting equipment.

The recommended specific levels of relative voltage changes and modulation frequencies to be applied are given in Table 1. The test levels in this table are partly taken from the flickermeter performance test specifications given in Table 5 of IEC 61000-4-15:2010, and from the test level at 8,8 Hz given in Table 2b of IEC 61000-4-15:2010. The latter frequency is the most sensitive frequency over the frequency range of interest.

The rectangular modulation pattern should be applied with a duty cycle of $50 \% \pm 2$ percentage point (*pp*), and the transition time from one voltage level to the next should be less than 0,5 ms. All test frequency and level combinations will give a short-term flicker value of $P_{st}^V = 1$ corresponding to the threshold of the flicker irritability curve.

The duration of the voltage fluctuation applied to the EUT should be minimally 120 s (see footnote c of Table 1).

Table 1 – Voltage fluctuations – Test specification of voltage fluctuations applied at input a.c. power ports 230 V; 50 Hz

Rectangular amplitude modulations with duty cycle of 50 % ^{a c d}		
Voltage changes per minute <i>cpm</i>	Modulation frequency f_m Hz	Relative voltage fluctuation $d = \Delta U/U$ %
39	0,325 0	0,894
110	0,916 7	0,722
1 056	8,8	0,275 ^b
1 620	13,5	0,407
4 000	33,3	2,343

^a See Table 5 of IEC 61000-4-15:2010.

^b See Table 2b of IEC 61000-4-15:2010 for $P_{inst} = 1$; the value of $d = 0,196$ % is increased to 0,275 % to give $P_{st} = 1$.

^c The duration of the voltage fluctuation and recording of the illuminance is recommended to be minimally 180 s (60 s for the transient response of the flickermeter's filters and 120 s for the duration of the statistical evaluation of the flicker level in block d, see A.2.5). First of all, the transient response of the light flickermeter's filters shall be considered, which is dominated by the illuminance adapter (block a, see A.2.2). The time constant of this filter is set at 10 s, reaching the 90 % of the value corresponding to the steady state response at approximately 50 s. In addition, the evaluation period should contain an integer number of voltage fluctuation periods. For the set of test modulation frequencies given in this table, the minimum duration to achieve an integer number of voltage fluctuation periods in all the test cases is 120 s.

^d Recommended absolute tolerance for the duty cycle is ± 2 *pp*, for the modulation frequency the recommended tolerance is ± 1 % and for the relative voltage fluctuation the recommended tolerance is ± 2 %

6 Test setup and equipment

6.1 General

The block diagram of the test setup is shown in Figure 3. One can distinguish three parts in the setup:

- generation of the test voltage,
- application of the test voltage to the EUT, photometric measurement of the EUT in an optically shielded environment,
- measurement and control equipment.

More details of the equipment properties are described below.

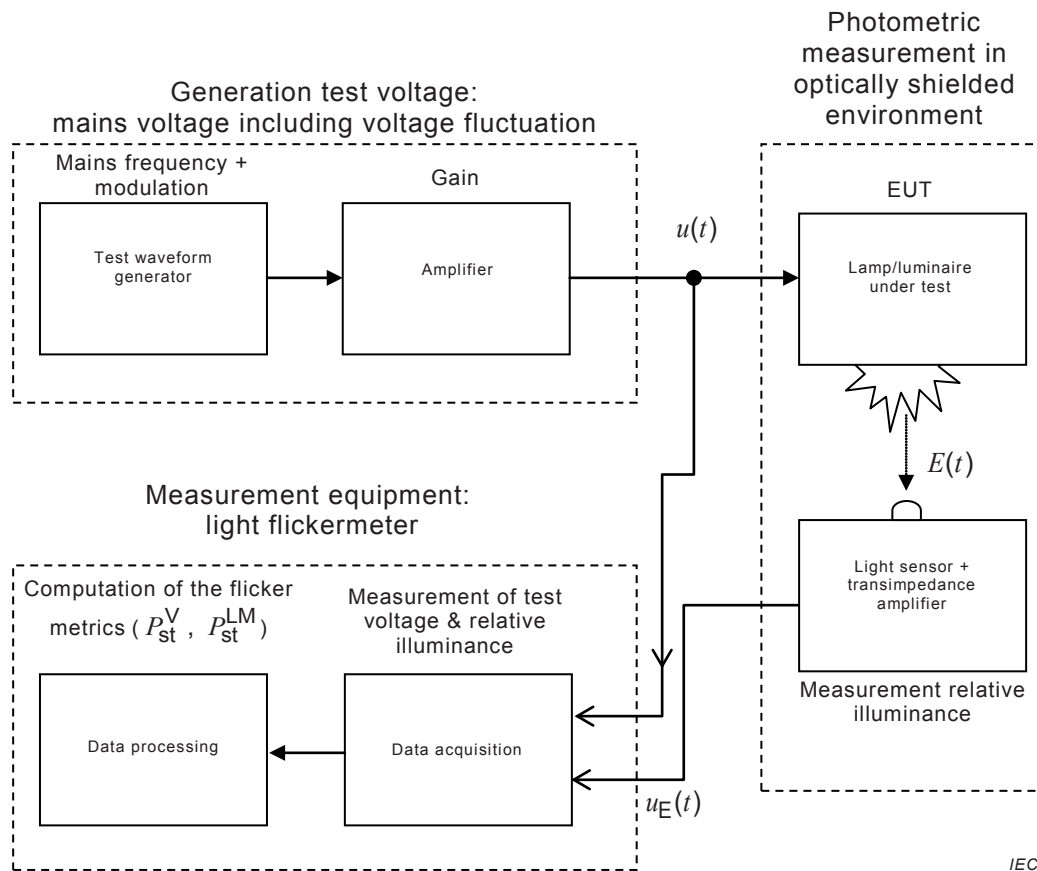

Figure 3 – Block diagram voltage-fluctuation immunity test

6.2 Test voltage

The test voltage, which consists of the mains voltage with a rectangular amplitude modulation, can be synthesised using waveform generator and an amplifier. This may be implemented also by using a separate waveform generator for the modulating signal that is applied to a generator that makes the 50 Hz mains signal.

It is important that the equipment for generating the amplitude modulation is capable of generating voltage fluctuations well below the lowest test level of $d = 0,275\%$ at 8,8 Hz (see Table 1).

Care should be taken that no other disturbing signals than the amplitude modulation are present (see 5.2 and 7.4.3 for the verification).

The characteristics of the test voltage should be verified by either measurement through an oscilloscope or by direct application of an IEC flickermeter (see 7.3.2).

6.3 Optical test environment

The illuminance of the EUT is to be measured for processing by the light flickermeter. There is no need for measuring the absolute value. Only the relative illuminance is to be determined.

The EUT and the light sensor are to be located in an optically shielded environment to avoid disturbances from light sources other than the EUT.

The test environment should be also mechanically robust to avoid vibrations of the EUT and light sensor that may give rise to unwanted variations in the illuminance.

It is recommended that the light output of the EUT is measured indirectly via a reflecting surface. This is especially true for lighting equipment with a spatial distribution of light sources (e.g. TL, TLED, 2D LED matrix).

An integrating sphere, like an Ulbricht sphere, may be applied. This may be convenient because then the orientation and alignment of the EUT with respect to the light sensor is less critical.

6.4 Light sensor and amplifier

A photodiode with a filter and an appropriate amplifier is to be applied for measuring the illuminance (or more specific: the relative illuminance) of the EUT.

The photodiode, optical filter and amplifier combination should satisfy the following characteristics:

- a) the optical filter should match the photodiode to the eye sensitivity curve of CIE 1931 which is the CIE 1931 Standard Observer function specified in ISO 11664-1:2007 [3];¹
- b) the cut-off frequency of the amplifier should enable measurement of all flicker-relevant frequencies. A cut-off frequency of 2 kHz is recommended;
- c) the output voltage of the amplifier should vary linearly with the illuminance and no offset-voltage should be present.

6.5 Signals to be measured

The output voltage $u_E(t)$ of the light sensor amplifier is measured as a function of time over a period T_{test} . The output voltage $u_E(t)$ varies linearly with the illuminance $E(t)$:

$$u_E(t) = C_A \cdot E(t) \text{ is measured between } 0 < t < T_{\text{test}} \quad (6)$$

where C_A is the constant including the gain of the amplifier and which relates the output voltage of the light sensor amplifier to the illuminance.

In addition, the mains voltage including the voltage variation $u(t)$ is measured over the same time period.

The signals can be measured with an oscilloscope. It is recommended to apply an appropriate low-pass filter in the oscilloscope to limit the noise.

¹ Numbers in square brackets refer to the Bibliography.

The measured signals are to be recorded for further processing.

6.6 Signal processing

6.6.1 Anti-aliasing filter

The light output of some types of lamps may contain spectral components at frequencies well above 100 Hz (kHz-range) that are not producing visible flicker. Depending on the sampling frequency (see 6.6.2) these higher frequency components may be undersampled and this may lead to aliasing which gives artefacts in the light sensor signal. It is recommended to avoid such aliasing effects by application of a low-pass filter between the amplifier output of the light sensor and the measurement system.

EXAMPLE A 1st order low-pass filter with 3 dB cut-off frequency of 1 kHz will attenuate a factor 10 at 3 kHz. For 3 kHz, the sampling frequency is then at least 6 kHz.

6.6.2 Sampling frequency

For processing of the signals, in accordance with the Nyquist criterion, the sampling frequency shall be at least twice the bandwidth of the signal, which is approximately twice the highest frequency within the signal to be measured.

The mains voltage signal of 50 Hz with amplitude modulation ranging from 0,5 Hz up to 40 Hz has a spectrum of interest up to the sum of the mains and the modulation frequency. Hence, the frequency range of interest of the mains voltage signal extends roughly up to 100 Hz.

The illuminance signal has a spectrum of interest that is at least twice the spectrum of the mains signal for incandescent lamps. For non-incandescent type of lighting equipment much higher frequencies may be present depending on the driver technology applied. As these much higher frequencies are not of interest for flicker these should be filtered before sampling (see 6.6.1).

Interharmonics may also cause beat frequencies that may produce light flicker.

Still for calculating flicker, the highest frequency of interest is determined by the highest modulation frequency, the mains frequency and the possible interharmonics. The flickermeter, and also the light flickermeter contain a bandpass filter (0,05 Hz to 35 Hz), see Annex A.

Although the highest frequency of interest in the illuminance signal is limited to approximately 200 Hz, the way the various digital filters are implemented usually requires oversampling and therefore much higher sampling rates (see [9][12]).

For the Matlab implantation of the IEC flickermeter given in [14] a sampling rate of at least 2 kHz is recommended. Therefore, for the light flickermeter a sampling rate of at least 4 kHz is recommended as the bandwidth of the illuminance signal resulting from the mains voltage and its fluctuations is approximately twice the bandwidth of the mains signal. As explained in 6.6.1, the sampling frequency shall be selected also in conjunction with the cut-off frequency of the anti-aliasing filter applied. For practical low-pass filters with a cut-off frequency around 1 kHz, a sample rate of at least 10 kHz is recommended.

An example of a recorded illuminance signal over a period of 1 s is given in Figure 4. The 100 Hz ripple, which is typical for an incandescent lamp, and the additional modulation resulting from the amplitude modulation of the mains voltage at 8,8 Hz ($d = 0,275 \%$) are clearly visible.

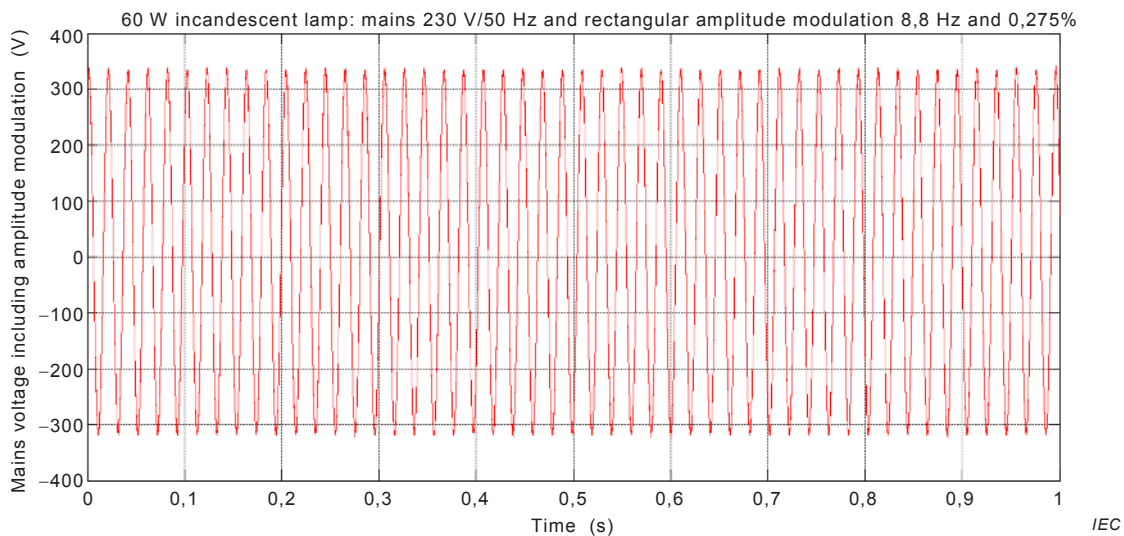

a) Mains voltage fluctuation with rectangular modulated of 8,8 Hz and $d = 0,275 \%$

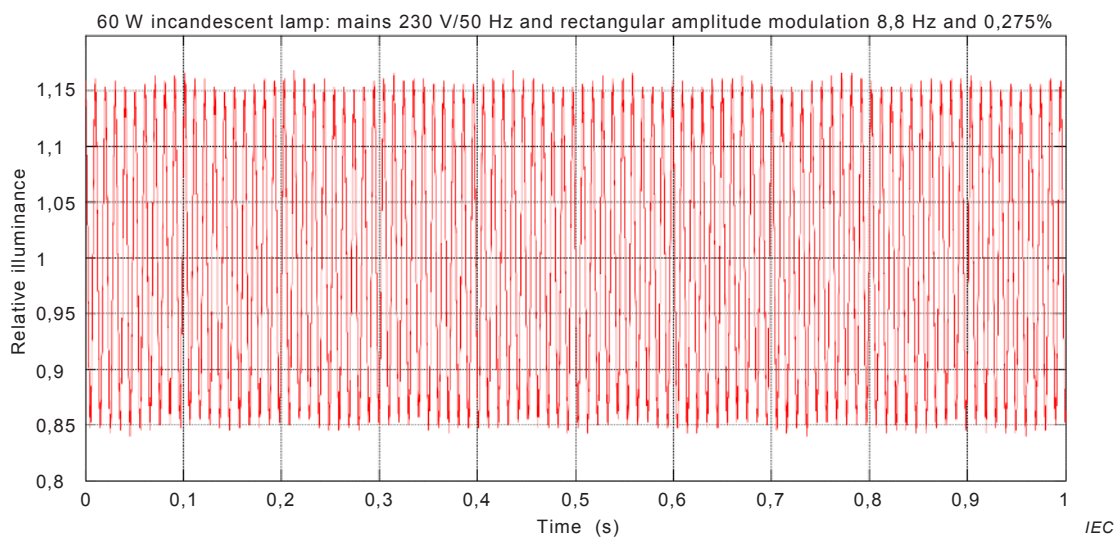

b) Illuminance signal of a 60 W incandescent lamp including a 100 Hz ripple and an additional modulation due to the modulated mains voltage fluctuation (a)

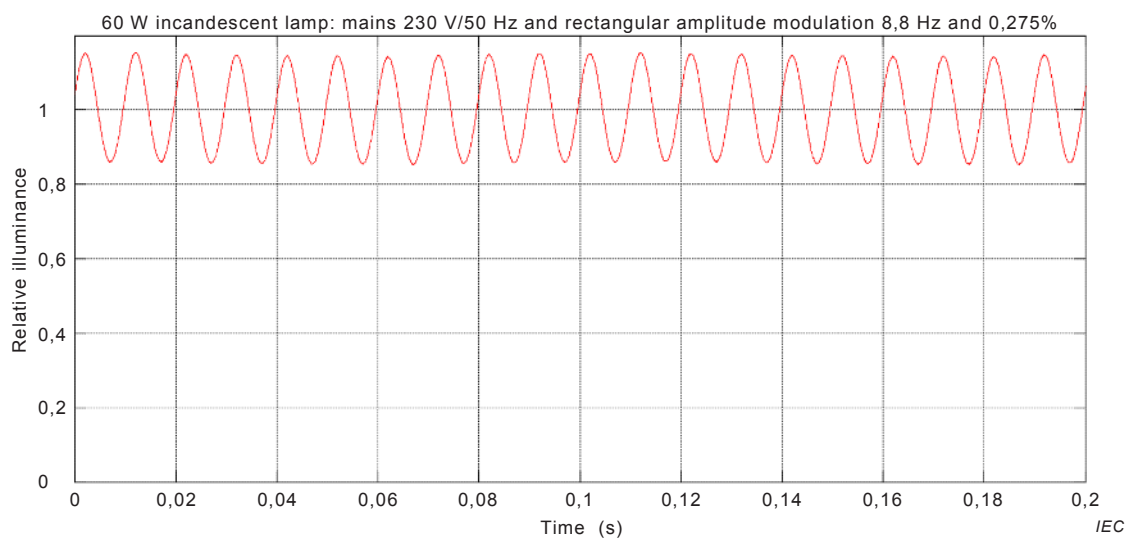

c) Same as b) zoomed over 0,2 s and vertical range from 0 to 1,2

Figure 4 – Example of a recorded mains voltage fluctuation and illuminance signal of a 60 W incandescent lamp

6.6.3 Signal resolution

As a result of the recommended P_{st}^V -noise level of 0,2 (see 5.2), the uncertainty of the relative voltage fluctuation should be 0,2 times the lowest level of the relative voltage fluctuation, which is 0,2 % at 8,8 Hz amplitude modulation. Hence the uncertainty of the relative voltage fluctuation should be less than 0,055 % (-65 dB). This means that in case of application of an AD convertor more than 10 bits is required (signal-to-quantization-noise ratio for 11 bits = -66 dB).

7 Verification procedure

7.1 General

The test is subject to uncertainties. Annex B gives an overview of the main influence quantities for the uncertainty.

In order to limit uncertainties of the test, it is recommended to perform a number of verification tests at regular intervals.

The verifications tests are described in the following subclauses.

7.2 Light flickermeter

Verification of the light flickermeter may be performed using the procedure given in Clause A.3.

It is recommended that the outcome of the verification satisfies the following for all test frequencies given in Table A.1:

$$\left| P_{st}^E - P_{st}^{LM} \right| / P_{st}^E \times 100 \% < 5 \% \quad (7)$$

where P_{st}^E is the flicker severity value of the standardised illuminance waveform $E(t)$ applied; see Equation (A.7), and P_{st}^{LM} is the P_{st} -value measured at the output of the light flickermeter using

$$P_{st}^E = \alpha, \quad (8)$$

for $\alpha = 1/4, 1/2, 1, 2, 3, 4$ and 5

where α is the fixed multiplication factor with which all the d_E values given in Table A.1 have to be multiplied.

7.3 Mains voltage parameters without modulation

7.3.1 Nominal voltage level

The rms-level of the mains signal should be measured when no modulation is applied.

It is recommended that the rms-value satisfies:

$$U [\text{rms}] = 230 \text{ V} \pm 0,5 \% \quad (9)$$

7.3.2 Mains frequency

Verify that the mains frequency f satisfies the following:

$$f = 50 \text{ Hz} \pm 0,5 \%, \quad (10)$$

7.4 Voltage fluctuation level

7.4.1 General

It is important to verify the level of the voltage fluctuation when a certain modulation is applied. Two options can be used for this verification.

7.4.2 Option 1: measure the actual modulation frequencies and voltage levels

Verify that the modulation frequencies f_m given in Table 1 satisfy the following:

$$f_m \text{ is within } \pm 1 \% \text{ of the nominal values given in Table 1} \quad (11)$$

Apply a 1 % rectangular modulation at a frequency of 2 Hz. Measure the overall change of the peak value of the mains voltage at a transition. This voltage change should be (see Table 1):

$$\Delta u = 230 \text{ V} \times 1 \% \times \sqrt{2} = 3,25 \text{ V} \pm 2 \% \quad (12)$$

7.4.3 Option 2: measure P_{st} -values using a flickermeter

A flickermeter can be applied for verification of the voltage fluctuation levels as follows.

Measure the P_{st} -noise level of the mains ($P_{st}^V|_{\text{noise}}$) using the flickermeter, when no modulation is applied. Verify that (see 5.2)

$$P_{st}^V|_{\text{noise}} < 0,2 \quad (13)$$

Apply rectangular amplitude modulations to the mains in accordance with the specified test levels given in Table 1. Measure the actual P_{st} -level using the flickermeter (P_{st}^V) and verify whether the mains signal including the voltage variation satisfies the following (see Table 1):

$$P_{st}^V = 1 \pm 2 \% \quad (14)$$

7.5 Light sensor and amplifier

Verify the absence of an offset voltage by covering the light sensor such that no light can enter the photodiode. Verify that voltage at the output of the amplifier is less 0,1 % of the maximum voltage level of the amplifier (within its operating range).

Verify the linearity of the sensor by positioning the photodiode at different distances from a stable small light source in an optical chamber. The voltage should vary linearly with $1/r^2$.

Verify the clipping level of the voltage output of the amplifier, and make sure that tests are executed below this level.

7.6 Test environment

Install the light sensor in the test environment where no EUT is present or in operation. Close the optical test environment and put all (other than the EUT) test equipment into operation.

Verify the absence of electromagnetic disturbances and/or unwanted light ingress in the optical test environment by checking the voltage signal at the output of the amplifier.

Electrical shielding of light sensor and amplifier is highly recommended.

7.7 Light flicker noise

In theory, if the illuminance from the EUT would be constant, then the $P_{st}^{LM} = 0$. In practice however, the light sensor and its amplifier and the light flickermeter may give a non-zero result if the illuminance is constant. This is called the light flicker noise level $P_{st}^{LM}|_{noise}$. It should be noted that this noise level differs from the noise $P_{st}^V|_{noise}$ due to residual voltage variations of the test signal (see 5.2 and 7.4.3).

The light flicker noise level $P_{st}^{LM}|_{noise}$ can be verified as follows.

Install a suitable a.c.-fed light source, either an incandescent or halogen lamp. Feed the lamp with a constant voltage without modulation.

Measure the illuminance and determine the actual P_{st} -level using the light flickermeter and verify whether the actual level satisfies the following:

$$P_{st}^{LM}|_{noise} < 0,1 \quad (15)$$

8 Test procedure

The following procedure for execution of a test is recommended:

- a) mount the EUT in the optically shielded enclosure;
- b) switch on the EUT and apply sufficient stabilization time;
- c) if the EUT has a light regulation function, then the light output should be set at 50 % of the maximum light output (see Clause 9 for details);
- d) apply the recommended settings for the data acquisition (duration test, sample rate, filtering);
- e) set the test voltage in accordance with the recommended values of Table 1 ($P_{st}^V = 1$);
- f) measure the P_{st}^{LM} levels of relative illuminance waveform.

An example of a test of a 7 W LED lamp is given in Annex C.

9 Conditions during testing

The EUT should be tested within its intended operating and climatic conditions.

An appropriate stabilization time should be applied for the EUT before execution of the test. The specification of the EUT or the type of technology may indicate the typical stabilization time required.

The EUT should be operated as follows.

- The test should be applied while the EUT is operated as intended under normal operating conditions as laid down in the relevant product standard at stabilized luminous flux and at normal laboratory conditions.
- Testing is recommended at one combination of supply voltage and frequency, as specified by the manufacturer.
- An EUT including a light-regulating control should be tested at a light output level of 50 % ± 10 % from the maximum light output. If a light output level of 50 % is not available for the EUT including a light regulation function, the test shall be done at the level which is closest to 50 %. If two steps equally distant to 50 % are available, the lower level (<50 % shall be used for the test (see I-SH 01 [2] of IEC 61547 [1]).
- Luminaires and independent auxiliaries should be tested with light sources for which they are intended. Where such equipment can operate with light sources of different wattages, a light source of minimum wattage is recommended.
- If light sources can operate at different colours, select the colour that gives the maximum light output (modulation off).

10 Evaluation of the test result

The P_{st} -level that is measured by the light flickermeter will generally differ from the $P_{st} = 1$ test level that has been applied through the mains signal and the voltage fluctuation.

The results can be interpreted as follows.

$P_{st}^{EUT} = 1$, the EUT is experienced to have equal flicker behaviour as a 60 W incandescent lamp by an average observer, i.e. in 50 % of the cases flicker is experienced and in 50 % of the cases no flicker is experienced.

$P_{st}^{EUT} < 1$, the EUT is experienced to have a better flicker behaviour than a 60 W incandescent lamp by an average observer.

$P_{st}^{EUT} > 1$, the EUT is experienced to have a worse flicker behaviour than a 60 W incandescent lamp by an average observer.

11 Test report

The test report should contain all the information necessary to reproduce the test. In particular, it is advised to record the following information:

- a) identification of the EUT and any associated equipment, e.g. brand name, product type, serial number;
- b) the relevant operating conditions of the EUT (light output level);
- c) the types of interconnecting cables, including their length, and the interface port of the EUT to which they were connected;
- d) any specific conditions for use, for example cable length or type, shielding or grounding, or EUT operating conditions, which are essential for voltage-fluctuation immunity performance;
- e) the warming-up time of the EUT if applicable;

- f) identification of the test equipment, e.g. brand name, product type, serial number;
- g) any specific conditions necessary to enable the test to be performed;
- h) the nominal mains test frequency and voltage applied;
- i) the applied disturbance signals (modulation frequencies, relative modulation levels);
- j) the duration of the test for each disturbance signal;
- k) the acceptance criteria that have been applied (P_{st} -levels).

Annex A (informative)

Specification of the light flickermeter

A.1 The voltage flickermeter

The voltage fluctuation immunity test of the EUT during the test is done in an objective way by using the same P_{st} flicker metric of the voltage-based flickermeter specified in IEC 61000-4-15. This is done by measuring the illuminance variation of the EUT and applying it to an adapted flickermeter which uses illuminance as input instead of the voltage (see Figure 1). Illuminance flickermeters or light flickermeter are described in various papers [4][6][7]. The modification can be implemented by skipping the parts of the incandescent lamp model inside the current flickermeter (Figure A.1).

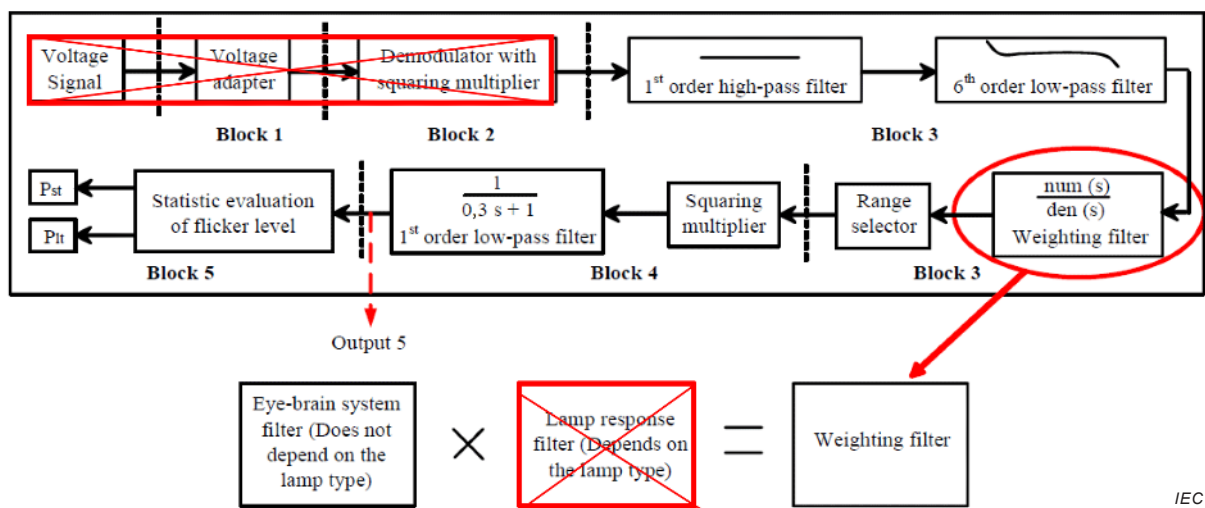

Red blocks indicate the incandescent-lamp specific blocks.

Figure A.1 – Structure of the IEC 61000-4-15 flickermeter which uses voltage as input

This means that the first two blocks of the standardized flickermeter are not applied and part of the third block is also omitted (see Figure A.1). The papers [4][6][7] describe in detail how to ‘delete’ the lamp response properties from the flickermeter.

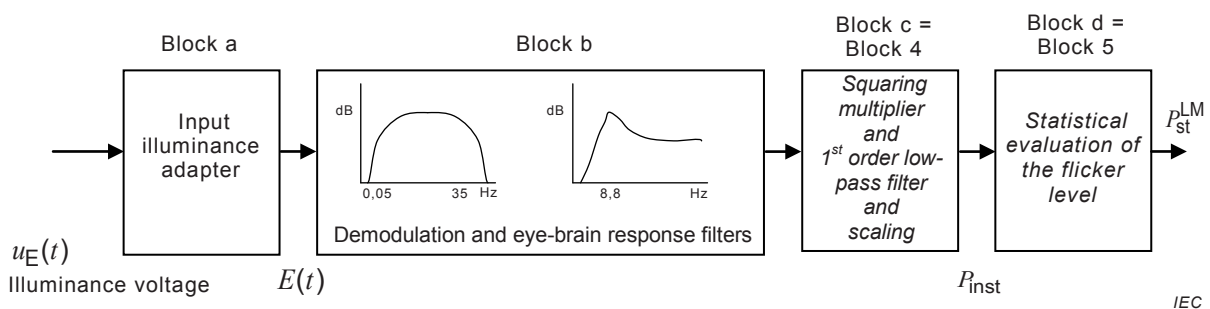

Figure A.2 – Structure of the light flickermeter

A.2 Specification of the light flickermeter

A.2.1 General

The various blocks of the light flickermeter depicted in Figure A.2 are specified in detail in Section 2.2 of [7]. More details on the functions of the blocks a to d are given in this clause.

A.2.2 Block a: illuminance adapter

This block contains an illuminance adapting circuit that scales the voltage $u_E(t)$ that is proportional to the illuminance to the d.c. value:

$$E(t) = \frac{u_E(t)}{\text{mean}(u_E(t))} \quad (\text{A.1})$$

The d.c. value can be obtained using a 1st order low-pass filter transfer function with frequency response as follows:

$$F_{\text{LPSC}}(s) = \frac{1}{\tau_{\text{LPSC}} \cdot s + 1} \quad (\text{A.2})$$

where

s is the complex Laplace variable, and

τ_{LPSC} is the filter time constant set at 10 s.

The corresponding filter cut-off frequency is 0,016 Hz.

Applying the signal normalisation makes the flicker perception independent on the illuminance level.

A.2.3 Block b: weighting filters

The first part of block b is identical to the first part of block 3 of the flickermeter. This first part includes a 1st order high-pass filter with a 3 dB cut-off frequency of 0,05 Hz and a 6th order low-pass (Butterworth) filter with a 3 dB cut-off frequency of 35 Hz for 230 V/50 Hz systems. See 5.4 of IEC 61000-4-15:2010.

The second part of block b is an eye-brain response weighting filter $F_{\text{WF}}^{\text{LM}}(s)$. It can be obtained by applying the weighting filter $F_{\text{WF}}^{\text{V}}(s)$ of the voltage flickermeter, compensated for the analog frequency response $F_{\text{RL}}(s)$ of the reference 60 W incandescent lamp (see Figure A.1):

$$F_{\text{WF}}^{\text{LM}}(s) = \frac{F_{\text{WF}}^{\text{V}}(s)}{F_{\text{RL}}(s)} \quad (\text{A.3})$$

The transfer function $F_{\text{WF}}^{\text{V}}(s)$ of the standard voltage flickermeter is defined in 5.5 of IEC 61000-4-15:2010.

For the analog frequency response $F_{\text{RL}}(s)$ of the reference 60 W incandescent lamp, the following 2nd order low-pass filter transfer function is used (see [7]):

$$F_{RL}(s) = \frac{K}{\tau_{L1} \cdot s^2 + \tau_{L2} \cdot s + 1} \quad (\text{A.4})$$

where $K = 3,57$, $\tau_{L1} = 0,02$ ms and $\tau_{L2} = 21,2$ ms.

After substitution of Equation (A.4) into (A.3) the weighting function $F_{WF}^{LM}(s)$ of the second part of block b can be written for a 230 V/50 Hz system as follows:

$$F_{WF}^{LM}(s) = \frac{0,041\,661 \cdot s^4 + 44,758 \cdot s^3 + 2\,715,6 \cdot s^2 + 29\,839 \cdot s}{s^4 + 196,32 \cdot s^3 + 11\,781 \cdot s^2 + 534\,820 \cdot s + 3\,505\,380} \quad (\text{A.5})$$

A.2.4 Block c: squaring multiplier, sliding mean filter and scaling

Block c has the same function as Block 4 of the flickermeter specified in 5.6 of IEC 61000-4-15:2010.

The output of block c represents the instantaneous flicker sensation P_{inst} . In the IEC flickermeter, the output of block 4 is normalised using a scaling factor to give a value of $P_{inst} = 1$ during a 10 min flicker test, when a sine wave modulated 50 Hz input signal, with a modulation frequency of 8,8 Hz and a modulation depth of 0,25 % is applied (see [11] for more details). The scaling factor S accounts for the magnitudes of the frequency responses of all the filters applied.

Also for the light flickermeter such a scaling factor has to be applied. To obtain the S value for the light flickermeter, the illuminance waveform of an incandescent lamp subjected to the same voltage signal used in the adjustment of the IEC flickermeter, has to be applied:

$$E(t) = \left\{ 1 + (d_E / 2) \cdot \sin(2\pi f_m t) \right\} \quad (\text{A.6})$$

where

$E(t)$ = the relative illuminance; see Equation (A.1), that shall produce $P_{inst} = 1$ at the output of block c,

$f_m = 8,8$ Hz = the modulation frequency = $1/T_m$,

$d_E = 0,630$ % = the relative change of the sinusoidal modulation of the illuminance in percentage.

NOTE The value of the illuminance relative amplitude ($d_E = 0,630$ %) was obtained from the average results of a sample of ten different 60 W incandescent lamps.

A.2.5 Block d: statistical analysis

Block d has the same function as Block 5 of the flickermeter specified in 5.7 of IEC 61000-4-15:2010.

The output of block d represents the short-term flicker severity P_{st} .

In order to ensure that the calculation of the short-term flicker severity P_{st} is performed during the steady-state of the flickermeter's filters, the first 60 s of the instantaneous flicker sensation P_{inst} , mainly corresponding to the transient response, should be discarded (see footnote c of Table 1).

A.3 Verification of the light flickermeter

The light flickermeter can be verified by applying standardised illuminance waveforms of which it has been demonstrated that it gives P_{st}^{LM} -levels exactly equal 1. This is done by applying a test voltage $u_E(t)$ that consists of a DC component plus a 100 Hz-ripple that is rectangular modulated as described in Equation (A.6) with the modulation parameters as given in Table A.1.

$$E(t) = \{1 - (d_r / 2) \cdot \cos(2\pi f_r t)\} \cdot \{1 + (d_E / 2) \cdot \text{signum}(\sin(2\pi f_m t))\} \quad (\text{A.7})$$

where

$E(t)$ is the relative illuminance; see Equation (A.1),

f_r equals 100 Hz = is the frequency of an illuminance ripple added to the DC value,

f_m is the modulation frequency = $1/T_m$,

d_r equals 22 % = the relative change of the 100 Hz-illuminance ripple in percent,

d_E is the relative change of the rectangular modulation of the illuminance in percent,

$\text{signum}(x)$ = the signum function, $\text{signum}(x) = 1$ for $x > 0$

$\text{signum}(x) = 0$ for $x = 0$

$\text{signum}(x) = -1$ for $x < 0$.

All test frequency and relative illuminance level combinations should give a short-term flicker value of exactly $P_{st}^{LM} = 1$ when applied to the light flickermeter.

Table A.1 – Test specification of illuminance fluctuations for lightmeter classifier

Rectangular amplitude modulations with duty cycle of 50 %; see Equation (A.7)		
Changes per minute	Modulation frequency	Relative illuminance change
<i>cpm</i>	f_m Hz	d_E %
39	0,325 0	2,538 6
110	0,916 7	2,047 3
1 056	8,8	0,683 2
1 620	13,5	0,778 0
4 000	33,3	2,002 7

Annex B (informative)

Uncertainty considerations

B.1 General

This annex gives information related to uncertainty of the P_{st} result of a voltage fluctuation immunity test. General information on uncertainty considerations of immunity tests can be found in IEC 61000-1-6 [B.1].²

B.2 General symbols

X_i	influence quantity
x_i	estimate of influence quantity X_i
δX_i	correction for influence quantity
$u(x_i)$	standard uncertainty of x_i
c_i	sensitivity coefficient
y	result of a measurement (the estimate of the measurand), corrected for all recognized significant systematic effects
$u_c(y)$	combined) standard uncertainty of y
$U(y) = k \cdot u_c(y)$	expanded uncertainty of y
k	coverage factor = 2

B.3 Measurand

The measurand associated with the voltage fluctuation immunity test is P_{st} , the short-term flicker metric.

B.4 Influence quantities

The Table B.1 gives the list of influence quantities that should be considered to derive the overall uncertainty of P_{st} .

All the influence quantities of the mains supply and the disturbance may be integrated into one uncertainty value of the P_{st} level associated with the test voltage.

The EUT is also an important, but also a difficult source of uncertainty, because the correction may vary significantly as a function of EUT technology. Generally the correction factor for SSL types of EUTs is much less than 1. This means that uncertainty contribution from the EUT is damped. For an incandescent lamp, the correction factor is 1. This means that the uncertainty of the mains supply voltage and its voltage fluctuation disturbance is transferred to the outcome of the test with a gain of 1.

For the sake of simplicity, in the remainder of this annex we will consider the uncertainty budget only for the reference 60 W incandescent lamp.

² Numbers in square brackets refer to the Reference document in B.6.

Table B.1 – P_{st} influence quantities and their recommended tolerances

Main category	Sub category	Importance	Nominal value	Recommended tolerance/value
Mains supply	Nominal voltage	Minor	230 V	$\pm 0,5$ %
	Frequency	Minor	50 Hz	$\pm 0,5$ %
Voltage fluctuation	Waveshape (transition time)	Minor		<0,5 ms
	Modulation frequency	Minor	See Table 1	± 1 %
	Relative voltage fluctuation	Relatively important	See Table 1	± 2 %
	Duty cycle	Minor	50 %	± 2 pp
	Noise level of the relative voltage fluctuation	Minor if $d < 0,0275$ % (0,1 times lowest value d)	n.a.	<0,055
P_{st} of the voltage fluctuation	Replaces all above given influence quantities for the voltage fluctuation	Relatively important	1	± 2 %
	Noise level	Relatively important	n.a.	<0,2
EUT	Technology	For 60 W-incandescent lamp, the voltage fluctuation is linearly transferred	n.a.	n.a.
	Warming-up time	Can be made negligible, but may be important, if ignored	Technology dependent	n.a.
	Dimming level	Important	50 % of max. light output	± 10 %
Light sensor, filter and amplifier	Sensitivity	Minor of nominal levels are well above noise level		
	Linearity/offset	Generally minor		
	Optical filter	Minor if compliant with CIE sensitivity curve		
	Bandwidth	Minor if > recommended value	2 kHz	n.a.
Test environment	Optical noise	Can be made negligible	0	n.a.
	EM disturbances	Can be made negligible	0	n.a.
Test procedure	Duration test	Minor if larger than both the transient of the lightmeter filter and the time period T_m corresponding to the modulation frequency	In relation to modulation frequency	
	Sampling rate	Minor, if the rate satisfies the recommended value in conjunction with a suitable anti-aliasing filter		
Light flickermeter	Noise level		0	<0,1
	Implementation uncertainty	To be determined by verification test	$P_{st} = 1/4, 1/2, 1, 2, 3, 4, 5$	± 5 %

B.5 Uncertainty budget

The second step in assessing uncertainty is to specify a mathematical model that combines the aggregate effect of the major influence quantities on the overall uncertainty to estimate the combined standard uncertainty u_c . A simple multiplicative model will suffice for most scenarios. The model:

$$P_{st} = P_{st}^0 \cdot G_1 \cdot G_2 \cdots G_N \quad (\text{B.1})$$

where:

- P_{st}^0 is the true value
- P_{st} is the measured value
- $G_1, G_2 \cdots G_N$ are multiplicative corrections (with associated uncertainties) due to the major influence quantities.

In case of testing an incandescent lamp, the major uncertainty contributions are

- the uncertainty resulting from the test voltage (TV): δP_{st}^{TV} ;
- the uncertainty of the light flickermeter (LFM): δP_{st}^{LFM} ;
- the uncertainty due to the noise (N) of the test voltage: δP_{st}^N .

The overall uncertainty, then can be expressed as:

$$P_{st} = P_{st}^{LFM} \cdot (1 \pm \delta P_{st}^{TV}) \cdot (1 \pm \delta P_{st}^{LFM}) \cdot (1 + \delta P_{st}^N) \quad (\text{B.2})$$

Subsequently, the expanded uncertainty is calculated in the logarithmic domain (see IEC 61000-1-6 [B.1] for details).

The tolerances of the light flickermeter and the test voltage, respectively $\pm 0,05$ and $\pm 0,02$, can be applied directly in the uncertainty budget with the same magnitude (normal distribution).

The uncertainty contribution from the test voltage fluctuation noise level (0,2) can be estimated as follows. The combination of two illuminance fluctuations having different fluctuation frequencies follow the quadratic addition law (Aileret), see Equation (3) in [10]. Hence, for an incandescent lamp also the combination of two voltage fluctuations follow the quadratic summation law. So, the uncertainty resulting from adding a residual (noise) voltage fluctuation to a wanted voltage fluctuation level can be calculated from

$$\delta P_{st}^N = \sqrt{(0,2)^2 + 1^2} - 1 \approx 0,02.$$

When filling out the three major contributions to the uncertainty, the uncertainty budget given in Table B.2 is obtained.

Hence, the expanded uncertainty for P_{st} is $U_c = \pm 0,05$. The major contribution to the uncertainty is from the light flickermeter.

B.6 Reference document

- [B.1] IEC TR 61000-1-6:2012, *Electromagnetic compatibility (EMC) – Part 1-6: General – Guide to the assessment of measurement uncertainty*.

Table B.2 – Uncertainty budget of the voltage fluctuation immunity test

Input quantity	x_i	Uncertainty of x_i (plus/minus)	Uncertainty of x_i				$c_i u(x_i)$ (minus)	$c_i u(x_i)$ (plus)
			(minus)	(plus)	Probability distribution function	divisor k		
		linear	dB	dB			dB	dB
Uncertainty light flickermeter	δP_{st}^{LFM}	0,05	-0,5	0,42	normal	2	-0,22	0,21
Uncertainty from the test voltage	δP_{st}^{TV}	0,02	-0,18	0,17	normal	2	-0,09	0,09
Uncertainty test voltage noise	δP_{st}^N	0,02	0,00	0,17	normal	2	0,00	0,09
Combined Standard Uncertainty (SCU)	u_c						0,24	0,24
Expanded Uncertainty	U_c	0,05					0,48	0,49

All sensitivity coefficients c_i are assumed to be equal to 1.

Annex C (informative)

Examples of a test result

C.1 EUTs

This annex gives test results for the following EUTs

- EUT1: a 60 W incandescent lamp,
- EUT2: a 9 W self-ballasted CFL lamp,
- EUT3: a 7 W self-ballasted LED lamp.

C.2 Recorded signals

Records have been made for 60 s with a sampling rate of 10 kHz. Snapshots of the recorded signals of EUT1 without mains voltage modulation and with modulation are given in respectively the Figures C.1 and C.2. Results of recorded illuminance signals of EUT2 and EUT3 with mains voltage modulation are given in the Figures C.3 and C.4.

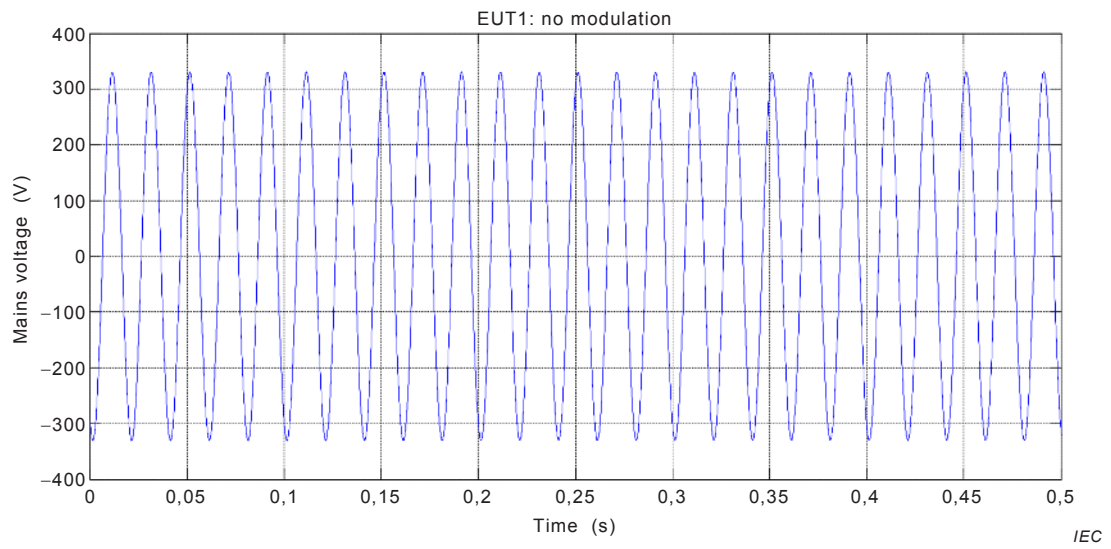

a) Mains signal

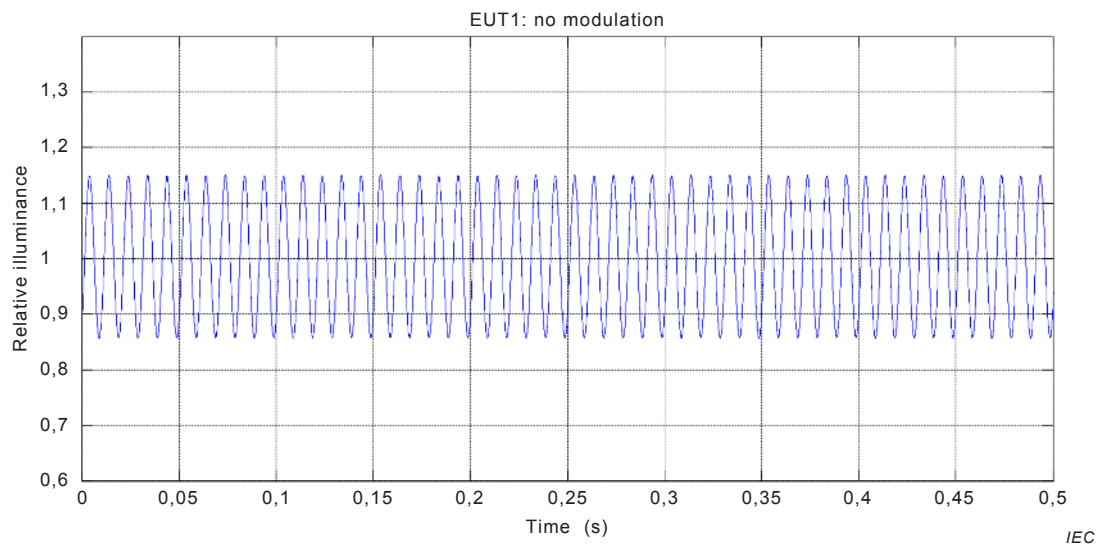

b) Relative illuminance

Figure C.1 – EUT1: recorded signals (no mains voltage modulation)

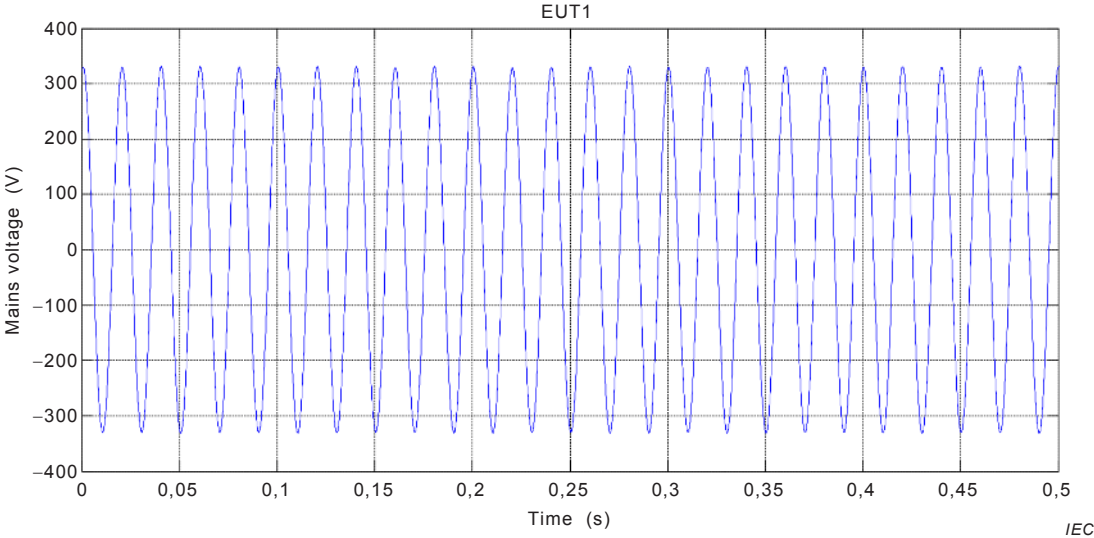

a) Mains signal with modulation $d = 0,407\%$ at $13,5\text{ Hz}$ ($P_{st} = 1$)

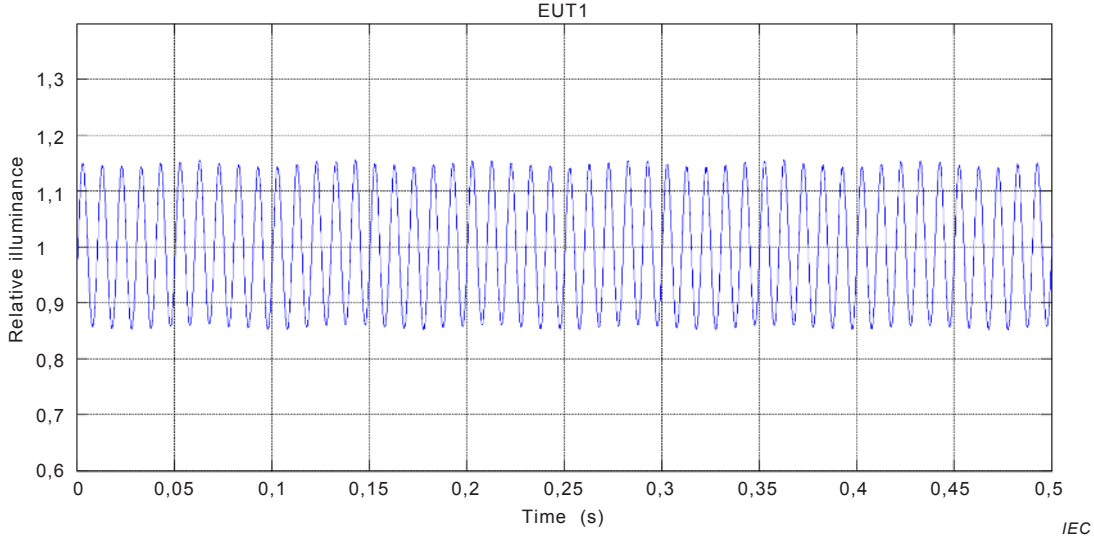

b) Relative illuminance

Figure C.2 – EUT1: recorded signals (with modulation)

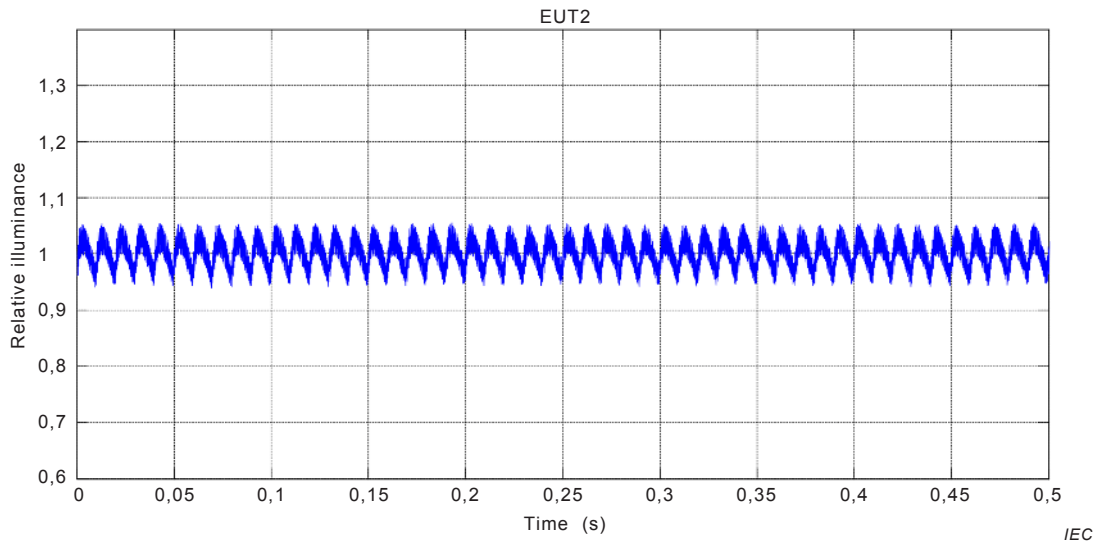

**Figure C.3 – EUT2: relative illuminance:
mains voltage modulation $d = 0,407\%$ at 13,5 Hz ($P_{st} = 1$)**

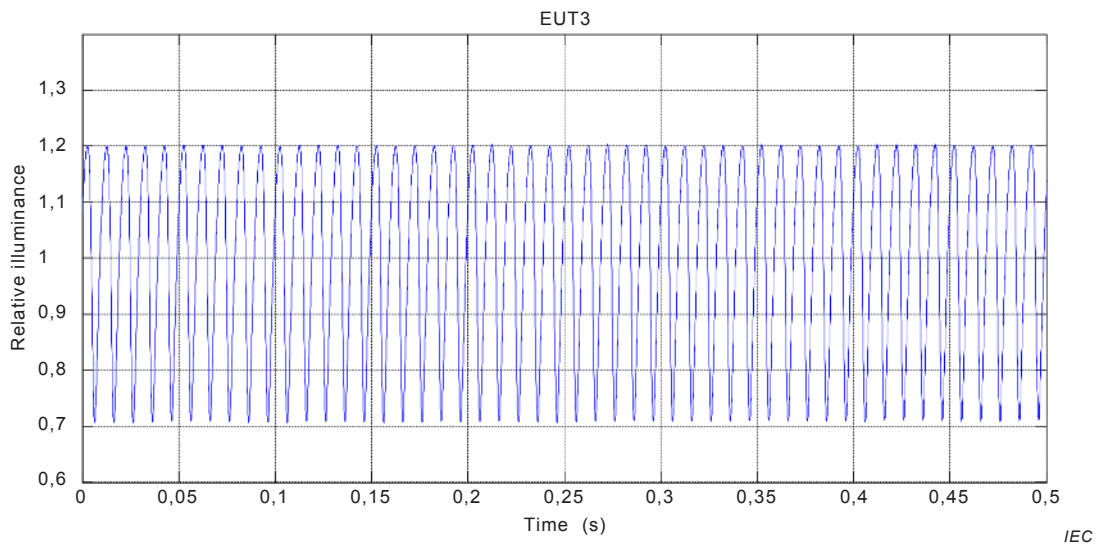

**Figure C.4 – EUT3: relative illuminance:
mains voltage modulation $d = 0,407\%$ at 13,5 Hz ($P_{st} = 1$)**

C.3 Results

The P_{st} -results corresponding to the recorded results given in the Figures C.1 and C.2 are given in Table C.1.

Table C.1 – Numerical results P_{st} calculations for three EUTs with and without modulation

EUT number			P_{st}		
	Hz	%	theoretical	at mains	at EUT
1	No modulation	No modulation	0	0,140	0,025
	0,325 0	0,894	1	0,987	1,005
	0,916 7	0,722	1	0,992	1,005
	8,8	0,275	1	0,989	1,009
	13,5	0,407	1	0,987	1,013
	33,3	2,343	1	0,986	1,042
2	No modulation	No modulation	0	0,135	0,023
	0,325 0	0,894	1	0,989	0,217
	0,916 7	0,722	1	0,988	0,208
	8,8	0,275	1	0,988	0,234
	13,5	0,407	1	0,986	0,284
	33,3	2,343	1	0,985	0,536
3	No modulation	No modulation	0	0,145	0,028
	0,325 0	0,894	1	0,993	0,167
	0,916 7	0,722	1	0,986	0,166
	8,8	0,275	1	0,989	0,188
	13,5	0,407	1	0,988	0,239
	33,3	2,343	1	0,986	0,466

From these results for these specific EUTs one may conclude that EUT2 and EUT3 (respectively CFL and LED lamps) are more immune to voltage fluctuations than the reference incandescent lamp EUT1.

The results of Table C.1 (with modulations) are also depicted in Figure C.5.

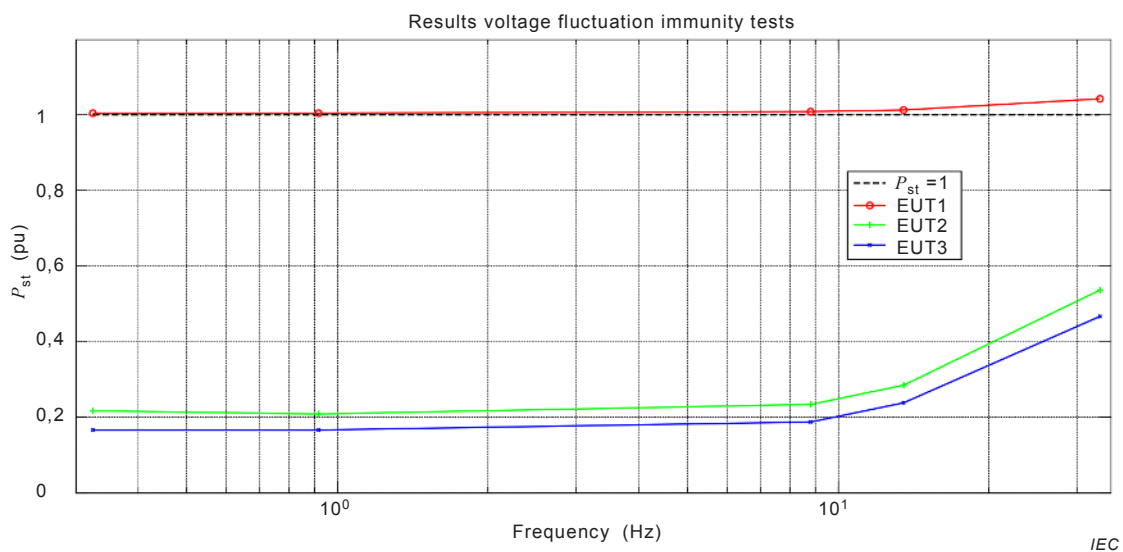

Figure C.5 – Graphical P_{st} results for three EUTs with rectangular modulation at five frequencies ($P_{st} = 1$)

Bibliography

- [1] IEC 61547:2009, *Equipment for general lighting purposes – EMC immunity requirements*
- [2] I-SH 01 (Interpretation sheet 1) to IEC 61547-2009, June 2013
- [3] ISO 11664-1:2007 (CIE S 014-1/E:2006), *Colorimetry – Part 1: CIE standard colorimetric observers*³
- [4] I. Azcarate, J.J. Gutierrez, A. Lazkano, P. Saiz, L.A. Leturiondo, K. Redondo, *Sensitivity to flicker of dimmable and non-dimmable lamps , Instrumentation and Measurement Technology Conference (I2MTC)*, 2012 IEEE International, 13-16 May 2012, pp. 344 – 347
- [5] K. Chmielowiec, *Flicker effects of different types of light sources*, 2011 11th International Conference on Electrical Power Quality and Utilisation (EPQU), 17-19 Oct. 2011
- [6] I. Azcarate J.J. Gutierrez, A. Lazkano, L.A. Leturiondo, P. Saiz, K. Redondo, J. Barros, *Type testing of a highly accurate illuminance flickermeter*, ICHQP 2012
- [7] J. Drápela, J. Šlezinger, A light-flickermeter – Part I: Design, Proceedings 11th International Scientific Conference Electric Power Engineering 2010, pp. 453
- [8] J. Drápela, J. Šlezinger, A light-flickermeter – Part II: Realization and verification, Proceedings 11th International Scientific Conference Electric Power Engineering 2010, pp. 459
- [9] T. Keppler, T. Keppler, N. R. Watson, S. Chen and J. Arrillaga, *Digital flickermeter realisations in the time and frequency domain*, Proceedings of the Australasian Universities Power Engineering Conference (AUPEC-2001), 23-26 September 2001, pp. 565
- [10] J. Ruiz, J. J. Gutierrez, A. Lazkano, S. Ruiz de Gauna, *A Review of Flicker Severity Assessment by the IEC Flickermeter*, IEEE Transactions on Instrumentation and Measurement, vol. 59, NO. 8, August 2010, pp. 2037
- [11] Testing the NPL flickermeter: www.npl.co.uk/electromagnetics/electrical-measurement/products-and-services/testing-the-npl-reference-flickermeter.
- [12] R. A. Losada, *Digital Filters with MATLAB*, The MathWorks, Inc., 11 May 2008 (Updated 16 Dec 2009): <http://www.mathworks.com/matlabcentral/fileexchange/19880-digital-filters-with-matlab>
- [13] Solcept Open Source Flicker Measurement-Simulator, www.solcept.ch/en/news-olds/flickersim/
- [14] P. Jourdan, Flickermeter Simulator: Power line flickermeter according IEC 61000-4-15, Matlab Central, 12 Jun 2009 (Updated 11 Jan 2010): www.mathworks.com/matlabcentral/fileexchange/24423-flickermeter-simulator
- [15] IEC 60050 (all parts), *International Electrotechnical Vocabulary*, available at <<http://www.electropedia.org/>>

³ ISO 11664-1:2007 specifies colour-matching functions for use in colorimetry. Two sets of colour-matching functions are specified: colour-matching functions for the CIE 1931 standard colorimetric observer and colour-matching functions for the CIE 1964 standard colorimetric observer. The colour-matching functions for the CIE 1931 standard colorimetric observer is to be applied.

British Standards Institution (BSI)

BSI is the national body responsible for preparing British Standards and other standards-related publications, information and services.

BSI is incorporated by Royal Charter. British Standards and other standardization products are published by BSI Standards Limited.

About us

We bring together business, industry, government, consumers, innovators and others to shape their combined experience and expertise into standards-based solutions.

The knowledge embodied in our standards has been carefully assembled in a dependable format and refined through our open consultation process. Organizations of all sizes and across all sectors choose standards to help them achieve their goals.

Information on standards

We can provide you with the knowledge that your organization needs to succeed. Find out more about British Standards by visiting our website at bsigroup.com/standards or contacting our Customer Services team or Knowledge Centre.

Buying standards

You can buy and download PDF versions of BSI publications, including British and adopted European and international standards, through our website at bsigroup.com/shop, where hard copies can also be purchased.

If you need international and foreign standards from other Standards Development Organizations, hard copies can be ordered from our Customer Services team.

Subscriptions

Our range of subscription services are designed to make using standards easier for you. For further information on our subscription products go to bsigroup.com/subscriptions.

With **British Standards Online (BSOL)** you'll have instant access to over 55,000 British and adopted European and international standards from your desktop. It's available 24/7 and is refreshed daily so you'll always be up to date.

You can keep in touch with standards developments and receive substantial discounts on the purchase price of standards, both in single copy and subscription format, by becoming a **BSI Subscribing Member**.

PLUS is an updating service exclusive to BSI Subscribing Members. You will automatically receive the latest hard copy of your standards when they're revised or replaced.

To find out more about becoming a BSI Subscribing Member and the benefits of membership, please visit bsigroup.com/shop.

With a **Multi-User Network Licence (MUNL)** you are able to host standards publications on your intranet. Licences can cover as few or as many users as you wish. With updates supplied as soon as they're available, you can be sure your documentation is current. For further information, email bsmusales@bsigroup.com.

BSI Group Headquarters

389 Chiswick High Road London W4 4AL UK

Revisions

Our British Standards and other publications are updated by amendment or revision.

We continually improve the quality of our products and services to benefit your business. If you find an inaccuracy or ambiguity within a British Standard or other BSI publication please inform the Knowledge Centre.

Copyright

All the data, software and documentation set out in all British Standards and other BSI publications are the property of and copyrighted by BSI, or some person or entity that owns copyright in the information used (such as the international standardization bodies) and has formally licensed such information to BSI for commercial publication and use. Except as permitted under the Copyright, Designs and Patents Act 1988 no extract may be reproduced, stored in a retrieval system or transmitted in any form or by any means – electronic, photocopying, recording or otherwise – without prior written permission from BSI. Details and advice can be obtained from the Copyright & Licensing Department.

Useful Contacts:

Customer Services

Tel: +44 845 086 9001

Email (orders): orders@bsigroup.com

Email (enquiries): cservices@bsigroup.com

Subscriptions

Tel: +44 845 086 9001

Email: subscriptions@bsigroup.com

Knowledge Centre

Tel: +44 20 8996 7004

Email: knowledgecentre@bsigroup.com

Copyright & Licensing

Tel: +44 20 8996 7070

Email: copyright@bsigroup.com



...making excellence a habit.™