



BSI Standards Publication

Short-circuit currents in three-phase a.c. systems —

Part 2: Data of electrical equipment for
short-circuit current calculations

National foreword

This Published Document is the UK implementation of IEC/TR 60909-2:2008. It supersedes PD 7639-2:1994 which is withdrawn.

The UK participation in its preparation was entrusted to Technical Committee PEL/73, Short circuit currents.

A list of organizations represented on this committee can be obtained on request to its secretary.

This publication does not purport to include all the necessary provisions of a contract. Users are responsible for its correct application.

© BSI 2009

ISBN 978 0 580 62329 5

ICS 17.220.01; 29.020; 29.240.20

This Published Document was published under the authority of the Standards Policy and Strategy Committee on 31 January 2009

Amendments issued since publication

Amd. No.	Date	Text affected
-----------------	-------------	----------------------



TECHNICAL REPORT

Short-circuit currents in three-phase a.c. systems – Part 2: Data of electrical equipment for short-circuit current calculations





THIS PUBLICATION IS COPYRIGHT PROTECTED

Copyright © 2008 IEC, Geneva, Switzerland

All rights reserved. Unless otherwise specified, no part of this publication may be reproduced or utilized in any form or by any means, electronic or mechanical, including photocopying and microfilm, without permission in writing from either IEC or IEC's member National Committee in the country of the requester.

If you have any questions about IEC copyright or have an enquiry about obtaining additional rights to this publication, please contact the address below or your local IEC member National Committee for further information.

IEC Central Office
3, rue de Varembe
CH-1211 Geneva 20
Switzerland
Email: inmail@iec.ch
Web: www.iec.ch

About the IEC

The International Electrotechnical Commission (IEC) is the leading global organization that prepares and publishes International Standards for all electrical, electronic and related technologies.

About IEC publications

The technical content of IEC publications is kept under constant review by the IEC. Please make sure that you have the latest edition, a corrigenda or an amendment might have been published.

- Catalogue of IEC publications: www.iec.ch/searchpub

The IEC on-line Catalogue enables you to search by a variety of criteria (reference number, text, technical committee,...). It also gives information on projects, withdrawn and replaced publications.

- IEC Just Published: www.iec.ch/online_news/justpub

Stay up to date on all new IEC publications. Just Published details twice a month all new publications released. Available on-line and also by email.

- Electropedia: www.electropedia.org

The world's leading online dictionary of electronic and electrical terms containing more than 20 000 terms and definitions in English and French, with equivalent terms in additional languages. Also known as the International Electrotechnical Vocabulary online.

- Customer Service Centre: www.iec.ch/webstore/custserv

If you wish to give us your feedback on this publication or need further assistance, please visit the Customer Service Centre FAQ or contact us:

Email: csc@iec.ch
Tel.: +41 22 919 02 11
Fax: +41 22 919 03 00



TECHNICAL REPORT

Short-circuit currents in three-phase a.c. systems – Part 2: Data of electrical equipment for short-circuit current calculations

INTERNATIONAL
ELECTROTECHNICAL
COMMISSION

PRICE CODE



ICS 17.220.01; 29.240.20

ISBN 2-8318-1016-1

CONTENTS

FOREWORD.....	4
1 General.....	6
1.1 Scope and object.....	6
1.2 Normative references.....	6
2 Data for electrical equipment.....	6
2.1 General.....	6
2.2 Data of typical synchronous machines.....	7
2.3 Data of typical two-winding, three-winding and auto-transformers.....	10
2.4 Data of typical overhead lines, single and double circuits.....	14
2.5 Data of typical high-voltage, medium-voltage and low-voltage cables.....	20
2.6 Data of typical asynchronous motors.....	35
2.7 Busbars.....	38
Annex A (informative) Information from National Committees.....	42
Bibliography.....	43
Figure 1 – Subtransient reactance of synchronous machines 50 Hz and 60 Hz (Turbogenerators, salient pole generators, motors SM and condensers SC).....	8
Figure 2 – Rated Voltage U_{rG} and rated power factor $\cos\varphi_{rG}$ of synchronous machines (Turbo generators, salient pole generators, motors and condensers 50 Hz and 60 Hz).....	9
Figure 3 – Unsaturated and saturated synchronous reactance of two-pole turbo generators 50 Hz and 60 Hz (relative values).....	9
Figure 4 – Three-winding transformer (No. 6 of Table 3).....	12
Figure 5 – Rated short-circuit voltage u_{kr} of unit transformers in power stations (ST) with or without on-load tap-changer.....	13
Figure 6 – Rated short-circuit voltages u_{kr} of network transformers.....	14
Figure 7 – Positive-sequence reactance $X'_{(1)} = X'_L$ of low-voltage and medium-voltage overhead lines 50 Hz, Cu or Al, with one circuit according to Equation (15) of IEC 60909-0.....	16
Figure 8 – Positive-sequence reactance $X'_{(1)} = X'_L$ of overhead lines 50 Hz (60 Hz- values converted to 50 Hz).....	19
Figure 9 – Type of overhead lines.....	20
Figure 10 – Single-core cable 64 kV / 110 kV with lead sheath [4].....	23
Figure 11 – Reduction factor depending on the inducing current for cables with one lead sheath and two overlapping steel tapes, $f = 50$ Hz [3].....	35
Figure 12 – Reduction factor depending on the inducing current for cables with three lead sheaths and two overlapping steel tapes, $f = 50$ Hz [3].....	35
Figure 13 – Ratio I_{LR}/I_{rM} of low-voltage and medium-voltage asynchronous motors, 50 Hz and 60 Hz.....	37
Figure 14 – Product $\cos\varphi_{rM} \times \eta_{rM}$ of low-voltage and medium-voltage motors, 50 Hz and 60 Hz.....	38
Figure 15 – Geometric mean distance $g_{L1L1} = g_{L2L2} = g_{L3L3}$ of the main conductors.....	39
Figure 16 – Factor α and β for the calculation of $X'_{(1)}$ given in Equation (34).....	40

Table 1 – Actual data of typical synchronous generators, motors and condensers	7
Table 2 – Actual data of typical two-winding transformers (NT: network; ST: power station)	10
Table 3 – Actual data of typical three-winding transformers	11
Table 4 – Actual data of typical autotransformers with and without tertiary winding	12
Table 5 – Actual data of typical overhead lines 50 Hz and 60 Hz	18
Table 6 – Actual data of typical electric cables.....	21
Table 7 – Equations for the positive-sequence and the zero-sequence impedance of cables.....	22
Table 8 – Single-core cables 64/110 kV, 2XK2Y, 3×1×240 ... 1 200 rm, Cu with lead sheath	24
Table 9 – 10-kV-cables N2XS2Y	25
Table 10 – 20-kV-cables N2XS2Y	26
Table 11 – Positive-sequence and zero-sequence impedance of four low-voltage single-core cables NYY 4×1× q_n ... (Case No. 2a in Table 7)	27
Table 12 – Low-voltage cable NYY	29
Table 13 – Low-voltage cable NYY with three and a half copper conductors	30
Table 14 – Low-voltage cable NYCWY with four copper conductors.....	32
Table 15 – Low-voltage cable NYCWY.....	33
Table 16 – Actual data of typical asynchronous motors.....	36
Table 17 – Actual data of distribution busbars.....	38
Table 18 – Example for the calculation of $X'_{(1)}$ for busbars using Figures 15 and 16	41
Table A.1 – Information received from National Committees	42

INTERNATIONAL ELECTROTECHNICAL COMMISSION

SHORT-CIRCUIT CURRENTS IN THREE-PHASE AC SYSTEMS –**Part 2: Data of electrical equipment
for short-circuit current calculations**

FOREWORD

- 1) The International Electrotechnical Commission (IEC) is a worldwide organization for standardization comprising all national electrotechnical committees (IEC National Committees). The object of IEC is to promote international co-operation on all questions concerning standardization in the electrical and electronic fields. To this end and in addition to other activities, IEC publishes International Standards, Technical Specifications, Technical Reports, Publicly Available Specifications (PAS) and Guides (hereafter referred to as "IEC Publication(s)"). Their preparation is entrusted to technical committees; any IEC National Committee interested in the subject dealt with may participate in this preparatory work. International, governmental and non-governmental organizations liaising with the IEC also participate in this preparation. IEC collaborates closely with the International Organization for Standardization (ISO) in accordance with conditions determined by agreement between the two organizations.
- 2) The formal decisions or agreements of IEC on technical matters express, as nearly as possible, an international consensus of opinion on the relevant subjects since each technical committee has representation from all interested IEC National Committees.
- 3) IEC Publications have the form of recommendations for international use and are accepted by IEC National Committees in that sense. While all reasonable efforts are made to ensure that the technical content of IEC Publications is accurate, IEC cannot be held responsible for the way in which they are used or for any misinterpretation by any end user.
- 4) In order to promote international uniformity, IEC National Committees undertake to apply IEC Publications transparently to the maximum extent possible in their national and regional publications. Any divergence between any IEC Publication and the corresponding national or regional publication shall be clearly indicated in the latter.
- 5) IEC provides no marking procedure to indicate its approval and cannot be rendered responsible for any equipment declared to be in conformity with an IEC Publication.
- 6) All users should ensure that they have the latest edition of this publication.
- 7) No liability shall attach to IEC or its directors, employees, servants or agents including individual experts and members of its technical committees and IEC National Committees for any personal injury, property damage or other damage of any nature whatsoever, whether direct or indirect, or for costs (including legal fees) and expenses arising out of the publication, use of, or reliance upon, this IEC Publication or any other IEC Publications.
- 8) Attention is drawn to the Normative references cited in this publication. Use of the referenced publications is indispensable for the correct application of this publication.
- 9) Attention is drawn to the possibility that some of the elements of this IEC Publication may be the subject of patent rights. IEC shall not be held responsible for identifying any or all such patent rights.

The main task of IEC technical committees is to prepare International Standards. However, a technical committee may propose the publication of a technical report when it has collected data of a different kind from that which is normally published as an International Standard, for example "state of the art".

IEC 60909-2, which is a technical report, has been prepared by IEC technical committee 73: Short-circuit currents.

This technical report is to be read in conjunction with IEC 60909-0 and IEC 60909-3.

This second edition cancels and replaces the first edition published in 1992. This edition constitutes a technical revision.

The significant technical changes with respect to the previous edition are as follows:

- Subclause 2.5 gives equations and examples for the calculation of the positive-, the negative and the zero-sequence impedances and reduction factors for high-, medium and low-voltage cables with sheaths and shields earthed at both ends.
- Subclause 2.7 gives equations and figures for the calculation of the positive-sequence impedances of busbar configurations.

The text of this technical report is based on the following documents:

Enquiry draft	Report on voting
73/142/DTR	73/145/RVC

Full information on the voting for the approval of this standard can be found in the report on voting indicated in the above table.

This publication has been drafted in accordance with the ISO/IEC Directives, Part 2.

A list of all parts of the IEC 60909, published under the general title *Short-circuit currents in three-phase a.c. systems*, can be found on the IEC website.

The committee has decided that the contents of this publication will remain unchanged until the maintenance result date indicated on the IEC web site under "<http://webstore.iec.ch>" in the data related to the specific publication. At this date, the publication will be

- reconfirmed,
- withdrawn,
- replaced by a revised edition, or
- amended.

A bilingual version of this publication may be issued at a later date.

SHORT-CIRCUIT CURRENTS IN THREE-PHASE AC SYSTEMS –

Part 2: Data of electrical equipment for short-circuit current calculations

1 General

1.1 Scope and object

This part of IEC 60909 comprises data of electrical equipment collected from different countries to be used when necessary for the calculation of short-circuit currents in accordance with IEC 60909-0.

Generally, electrical equipment data are given by the manufacturers on the name plate or by the electricity supplier.

In some cases, however, the data may not be available. The data in this report may be applied for calculating short-circuit currents in low-voltage networks if they are in accordance with typical equipment employed in the user's country. The collected data and their evaluation may be used for medium- or high-voltage planning purposes and also for comparison with data given by manufacturers or electricity suppliers. For overhead lines and cables the electrical data may in some cases also be calculated from the physical dimensions and the material following the equations given in this report.

Thus this technical report is an addition to IEC 60909-0. It does not, however, change the basis for the standardized calculation procedure given in IEC 60909-0 and IEC 60909-3.

1.2 Normative references

The following referenced documents are indispensable for the application of this document. For dated references, only the edition cited applies. For undated references, the latest edition of the referenced document (including any amendments) applies.

IEC 60909-0:2001, *Short-circuit currents in three-phase a.c. systems – Part 0: Calculation of currents*

IEC 60909-3:-1, *Short-circuit currents in three-phase a.c. systems – Part 3: Currents during two separate simultaneous line-to-earth short-circuit currents and partial short-circuit currents flowing through earth*

2 Data for electrical equipment

2.1 General

The data presented are necessary for the calculation of short-circuit currents. They are sometimes presented in the form of curve sheets and sometimes in the form of examples in tables. In the case of easy equations they are given for the calculations of positive-sequence and zero-sequence short-circuit impedances for overhead lines and cables.

¹ To be published.

In all, 15 National Committees provided information in response to a questionnaire sent out before the first edition of this report. Table 1 of the first edition of this report is given in Annex A.

In some cases, average values or characteristic trends as function of rated power, rated voltage, etc. are given.

2.2 Data of typical synchronous machines

Characteristic data of synchronous machines are listed in Table 1. The reactances are given as relative values related to $Z_{rG} = U_{rG}^2 / S_{rG}$ (see IEC 60909-0). Sometimes they are given in %.

In Figure 1 the sub-transient reactances of synchronous machines (generators, motors and condensers) in the direct axis of 50 Hz or 60 Hz machines are plotted as a function of the rated power.

Table 1 – Actual data of typical synchronous generators, motors and condensers

No	Type ^{a)}	Rated appar. power	Rated voltage and deviation ^{b)}		Power factor	Relative values of reactances and d.c time constant						Note	National Committee		
			S_{rG}	U_{rG}		$\pm p_G$	$\cos \varphi_{rG}$	x_d''	$x_{(2)}$ c)	$x_{(0)}$ d)	x_d e)			x_{dsat} f)	T_{DC} g)
			-	MVA		kV	%	-	-	-	-			-	s
1	TG2	64	13,8	±5	0,85	0,179	0,170	0,104	1,87	1,87	0,220	60 Hz	USA		
2	TG2	100	10,5	±5	0,80	0,134	-	-	1,77	1,45	0,246	50 Hz	Germany		
3	TG2	125	10,5	±5	0,80	0,160	0,180	0,08	2,13	1,87	0,460	50 Hz	ex-GDR		
4	TG2	180	10,5	±5	0,90	0,250	0,230	0,14	1,83	1,77	0,480	50 Hz	Austria		
5	TG2	353	18,0	±5	0,85	0,167	0,204	0,089	2,26	2,17	0,194	50 Hz	China		
6	TG2	388,9	17,5	±5	0,90	0,203	0,202	0,099	2,42	2,19	0,250	50 Hz	Australia		
7	SG14	48	10	±5	0,90	0,16	0,17	0,05	0,78	-	0,16	50 Hz	Italy		
8	SG20	290	18,0	±5	0,90	0,22	0,22	0,14	1,03	0,96	0,36	60 Hz	Japan		
9	SM2	1,45	10	+5 -10	0,90	0,166	0,166	0,046	1,63	-	0,04	50 Hz	ex-USSR		
10	SM3	3,40	4,0	±5	0,80	0,249	0,303	-	2,675	2,675	0,116	60 Hz	USA		
11	SC10	40	13,8	±5	0	0,119	0,129	-	1,33	1,33	0,1425	60 Hz	USA		
12	SC6	100	10,5	±5	0	0,20	0,25	0,095	1,78	1,60	0,57	50 Hz	ex-Czechoslovakia		
a) TG2: Two-pole turbo generator SG: Salient pole generator SM: Synchronous motor SC: Salient pole synchronous condenser b) $U_G = U_{rG} \left(1 \pm \frac{p_G}{100\%} \right)$						c) Negative-sequence reactance d) Zero-sequence reactance e) Unsaturated synchronous reactance f) Saturated synchronous reactance g) DC time constant for a three-phase terminal short circuit									

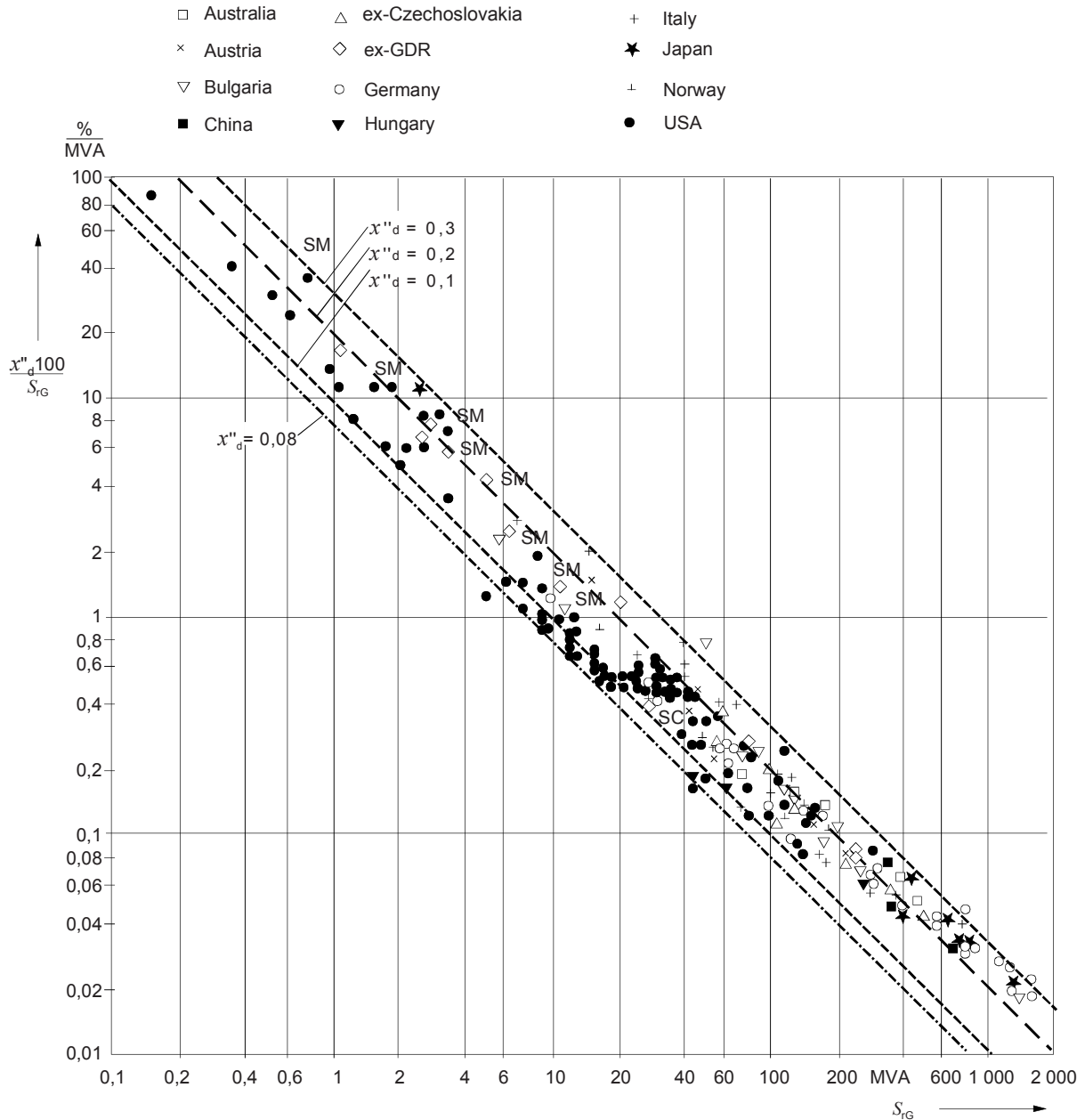

IEC 2028/08

Figure 1 – Subtransient reactance of synchronous machines 50 Hz and 60 Hz (Turbogenerators, salient pole generators, motors SM and condensers SC)

In Figure 2 the rated voltages and power factors of 50 Hz or 60 Hz synchronous machines (generators, motors) are plotted as a function of the rated power.

In Figure 3 unsaturated and saturated (x_{dsat}/x_d) synchronous reactances for 50 Hz and 60 Hz turbogenerators, used for the calculation of the steady state short-circuit current, are plotted as a function of the rated power.

Data are also given for the zero-sequence reactance. It is recommended that the relationship $X_{(0)}/X''_d = 0,5$ is used.

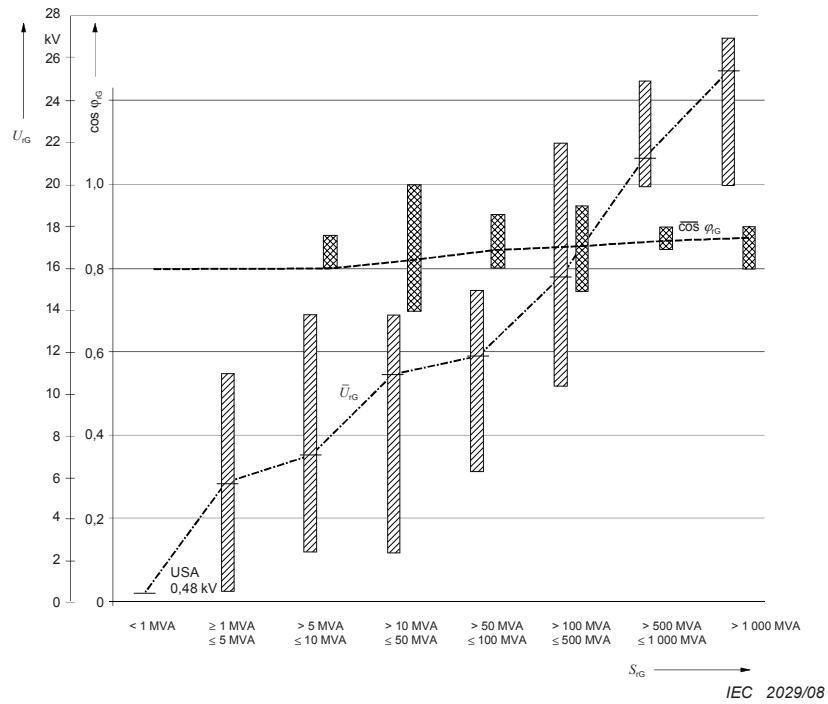

Figure 2 – Rated Voltage U_{RG} and rated power factor $\cos\phi_{RG}$ of synchronous machines (Turbo generators, salient pole generators, motors and condensers 50 Hz and 60 Hz)

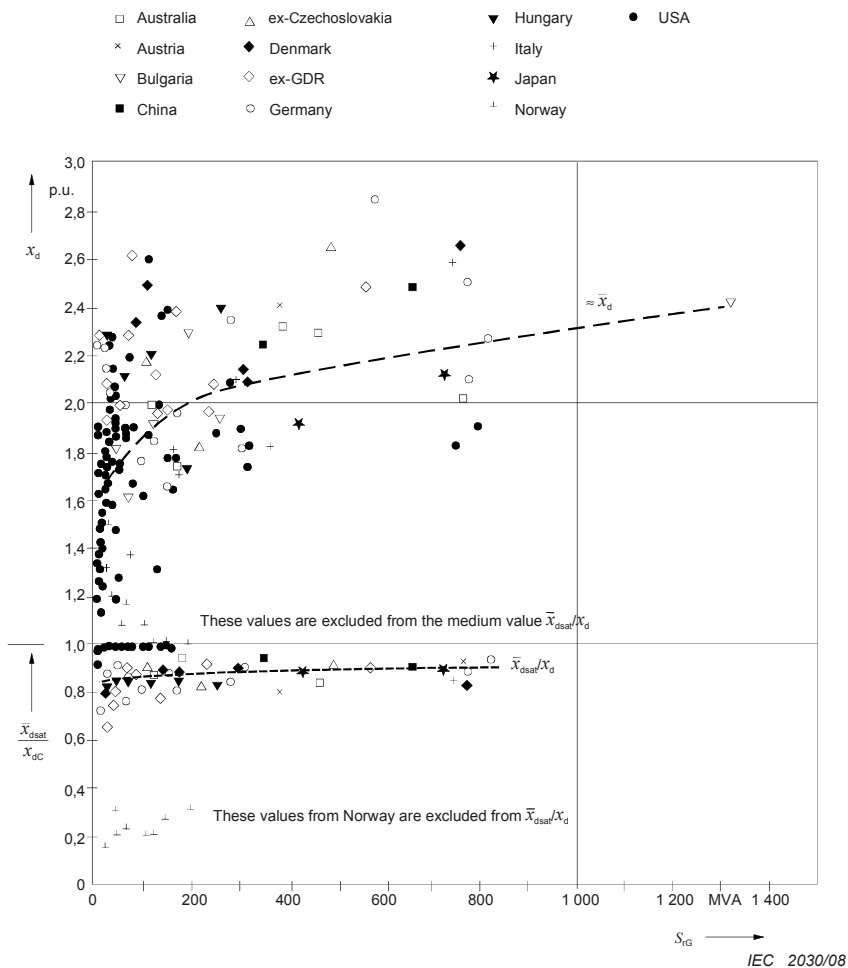

Figure 3 – Unsaturated and saturated synchronous reactance of two-pole turbo generators 50 Hz and 60 Hz (relative values)

2.3 Data of typical two-winding, three-winding and auto-transformers

In Tables 2, 3 and 4 characteristic data of two-winding, three-winding and auto-transformers are listed.

**Table 2 – Actual data of typical two-winding transformers
(NT: network; ST: power station)**

No	Rated appar. power	Rated voltage		Rated short-circuit voltage		Winding connection symbol HV LV	Side of Earthing	$\frac{X_{(0)}}{X_{(1)}}$	Tap-changer			Notes	National Committee	
		S_{rT}	U_{rTHV}	U_{rTLV}	u_{kr}				u_{Rr}	$\pm p_T$	u_{k+}			u_{k-}
		MVA	kV	kV	%				%	%	%			%
1	0,63	20	0,4	6,0	1,2	Dyn5	LV	≈ 1	± 5	off-load		NT, 50 Hz, 3 limb	ex-GDR	
2	24	33	11	24,2	1,12	YNyn0	HV, LV	0,7	± 10	24,1	25,3	NT, 50 Hz, 3 limb	UK	
3	31,5	112	22,2	12,8	0,37	YNd5	HV	≈ 1	± 18	13,9	10,5	NT, 50 Hz	Germany	
4	80	121	6,3	10,5	–	YNd5	HV	0,71	2×2,5	–	–	NT, 50 Hz, 3 limb	Bulgaria	
5 ^{a)}	500	400	132	26,1	0,30	YNynd5	HV, LV	$\approx 1,6$	± 13			NT, 50 Hz	Denmark	
6	20	138	13,2	10,58	0,49	Dyn1	LV	0,93	+2,5 – 7,5			ST, 60 Hz, 3 limb	USA	
7	25	132	6,3	10,5		YNd11	HV	1,0				ST, 59 Hz, 3 limb	Hungary	
8	180	110	10,5	12,0	0,221	Yd11		0,78	± 12			ST, 50 Hz	Austria	
9	390	350	23,0	15,92	0,554	YNd1	HV	1,0	+10 – 15	16,7	15,5	ST, 50 Hz, 3 limb	Australia	
10	780	230	21,0	15,3	0,2	YNd5	HV	$\approx 0,8$	± 15	16,7	14,3	ST, 50 Hz	Germany	

a) Two-winding transformer with an auxiliary winding in delta-connection (see Table 3).

Table 3 – Actual data of typical three-winding transformers

No	Rated apparent powers			Rated voltages			Rated short-circuit voltages			Winding connection symbol	Zero-sequence reactances related to side A			Note	National Committee
	S_{rTAB}	S_{rTAC}	S_{rTBC}	U_{rTA}	U_{rTB}	U_{rTC}	u_{krAB}	u_{krAC}	u_{krBC}		$X_{(0)A}$	$X_{(0)B}$	$X_{(0)C}$		
	MVA	MVA	MVA	kV	kV	kV	%	%	%		HV MV LV	Ω	Ω		
1	7,5	7,5	7,5	34,5	13,8	13,8	3,65	3,58	7,96	YN d1 d1	-	-	-	60 Hz 3 limb	USA
2	25	16	16	120	22	11	11,0	14,5	3,5	YN yn0 d11	99,0	-	3,15	50 Hz 3 limb	Hungary
3	31,5	31,5	31,5	110	38,5	6,3	10,5	17,5	6,5	YN yn0 d11	6,13	17,23	18,24	"	China
4	94	94	94	239	130	13,8	11,79	11,31	12,44	YN yn0 d11	32,39	39,23	36,31	"	Italy
5	125	42	42	230	63	20	11,7	10,6	5,9	YN yn0 d11	124,6	-	5,74	50 Hz 5 limb	ex-GDR
6	600	150	150	400	230	30	17,5	16,5	11,3	YN yn0 d5	50,5	-3,8	125,3	"	Austria

For the transformer No. 6 in Table 3 the following Figure 4 gives additional information. The low-voltage winding C (30 kV) is laying near the iron core, the medium-voltage winding B (230 kV) between the windings A and C. The high-voltage winding A has a main part and an additional tap winding connected to the on-load tap changer (see b in Figure 4) near the star point at the high-voltage side of the transformer.

The reactances X_A , X_B , X_C in the positive-sequence system can be calculated from the short-circuit voltages given in Table 3. Related to the high-voltage side A ($U_{rTA} = 400$ kV) the results are: $X_A = 51,1 \Omega$, $X_B = -4,4 \Omega$ and $X_C = 124,93 \Omega$ without impedance correction factors (see IEC 60909-0). The value X_C has a small negative value similar to $X_{(0)B}$ given in Table 3.

If only the star point at the high-voltage side is earthed then $X_{(0)T} = X_{(0)A} + X_{(0)C}$ shall be used. If, on the other side, only the star point at the medium-voltage side is earthed, then $X_{(0)T} = X_{(0)B} + X_{(0)C}$ is valid related to the high-voltage side or related to the medium-voltage side: $X_{(0)Tt} = (X_{(0)B} + X_{(0)C}) \times (230 \text{ kV})^2 / (400 \text{ kV})^2$.

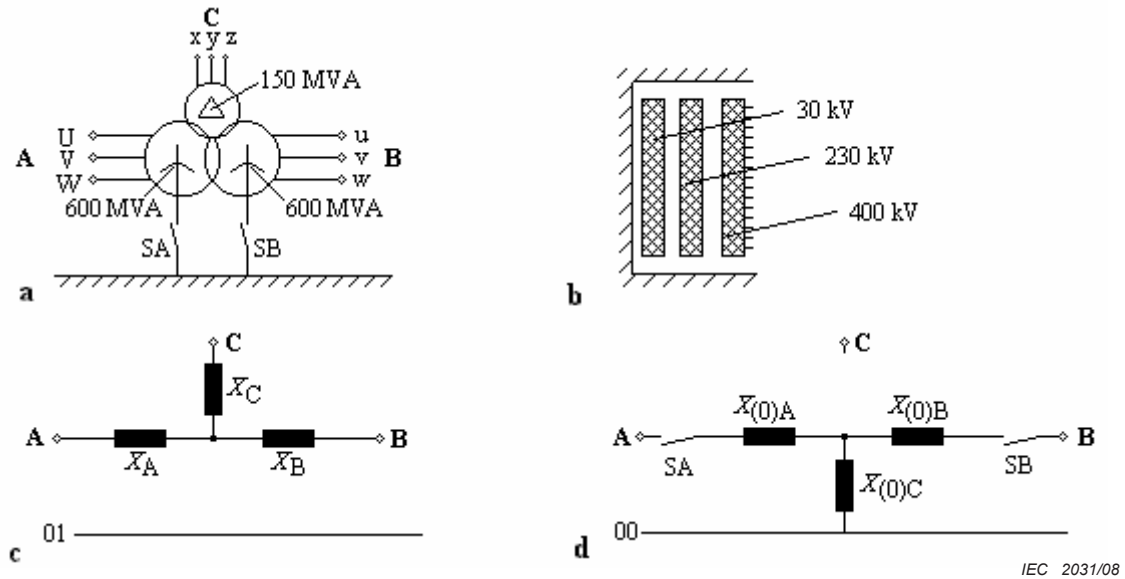

Key

- a terminals and rated apparent power of the windings A, B and C
- b position of the tree windings in relation to the iron core
- c positive-sequence reactances
- d zero-sequence reactances
- A HV-side
- B MV-side
- C LV-side
- SA, SB switches at the HV- and MV-side

Figure 4 – Three-winding transformer (No. 6 of Table 3).

Table 4 – Actual data of typical autotransformers with and without tertiary winding

No.	Rated apparent powers			Rated voltages			Rated short-circuit voltages			Winding connection symbol HV MV LV	Zero-sequence reactances related to side A			National Committee
	S_{rTAB}	S_{rTAC}	S_{rTBC}	U_{rTA}	U_{rTB}	U_{rTC}	u_{krAB}	u_{krAC}	u_{krBC}		$X_{(0)A}$	$X_{(0)B}$	$X_{(0)C}$	
	MVA	MVA	MVA	kV	kV	kV	%	%	%		Ω	Ω	Ω	
1	60	60	10	132	66	11	11,0	27,5	79,0	Y yn0 d1	61,6	4,19	1050	Australia
2	200	200	100	230	121	6,6	11,0	32,0	20,0	Y auto d11	30,4	0	54,2	ex-USSR
3	250	75	75	400	132	18	14,6	12,2	7,1	YN yn0 d11	10,11	-7,71	159,1	Hungary
4	250	100	100	400	121	10	12,9	13,1	6,3	YN yn0 d1	95,7	-13,1	113,9	ex-Czechoslovakia.
5	660	198	198	400	231	30	10,2	13,5	10,6	III d5 ^{a)}	24,35	0,35	84,65	Germany
6	250	250	-	230	130	-	11,6	-	-	YN yn0	24,55	-	-	Italy
7	300	300	-	235	165	-	7,0	-	-	YN yn0	13,0	-	-	Denmark

^{a)} Three separate poles.

In Figure 5 the rated short-circuit voltage is plotted as a function of the rated apparent power of unit transformers (ST) in power stations with or without on-load tap-changer. An average value for the rated short-circuit voltage is given by:

$$\frac{u_{kr}}{\%} = 8 + 0,92 \times \ln \frac{S_{rT}}{\text{MVA}} \quad (1)$$

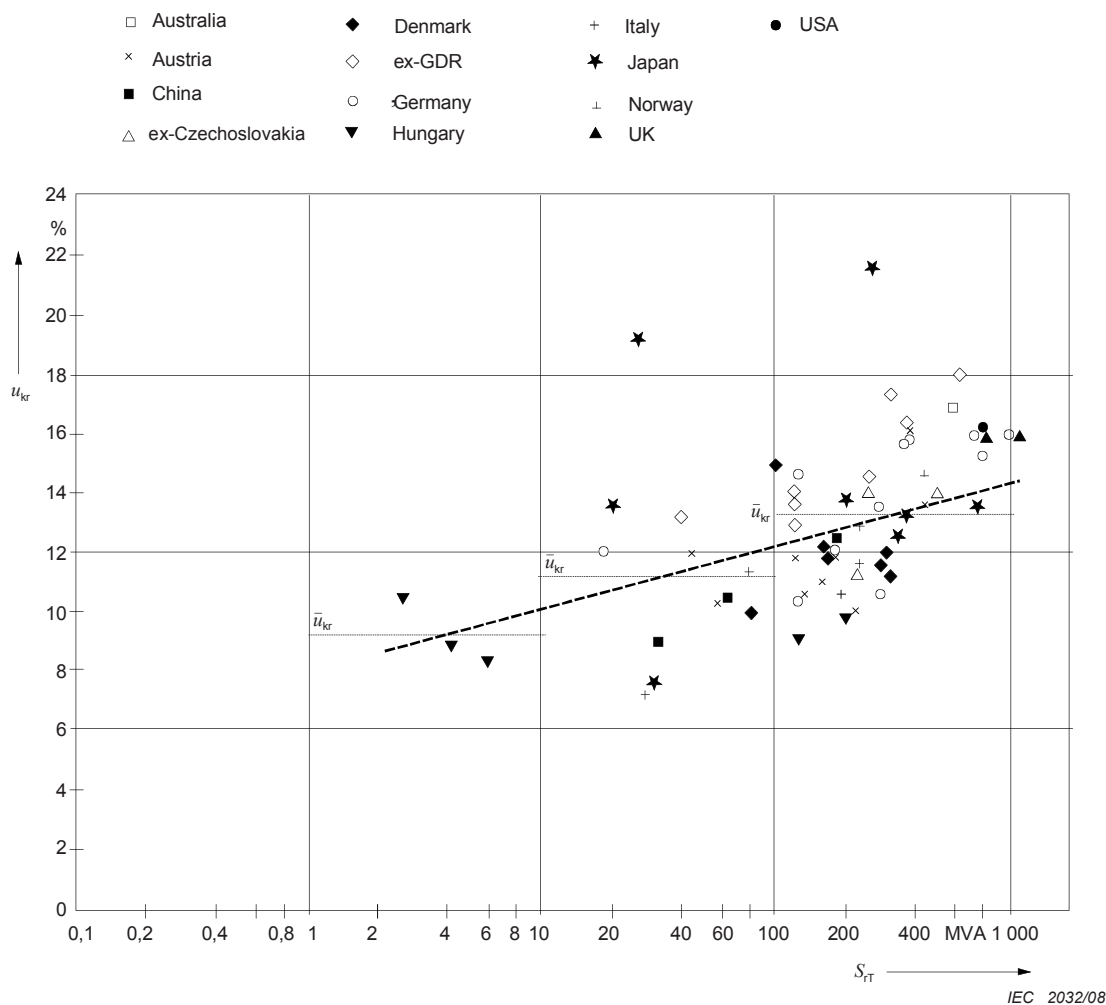

Figure 5 – Rated short-circuit voltage u_{kr} of unit transformers in power stations (ST) with or without on-load tap-changer

From Figure 5 it can be seen that the following average values for u_{kr} may be used:

$S_{rT} = 1 \dots 10 \text{ MVA: } u_{kr} = 9 \%$

$S_{rT} = 10 \dots 100 \text{ MVA: } u_{kr} = 11 \%$

$S_{rT} = 100 \dots 1000 \text{ MVA: } u_{kr} = 13 \%$

In Figure 6 the rated short-circuit voltage of network transformers (NT) is plotted as a function of the rated power. For low-voltage transformers $u_{kr} = 4 \%$ and 6% are commonly used.

In general u_{kr} values for auto-transformers are lower.

The u_{kr} values for network transformers in the UK are, on average, twice as high as those reported from other countries.

The relationship $X_{(0)}/X_{(1)}$ for two and three winding transformers, if only one star point is earthed, is as follows:

- YNd – transformers: $X_{(0)}/X_{(1)} = 0,8 \dots 1,0$
- Yzn – transformers: $X_{(0)}/X_{(1)} \approx 0,1$
- Ynyn0d – transformers: $X_{(0)}/X_{(1)} = 1,5 \dots 3,2 (3,7)$

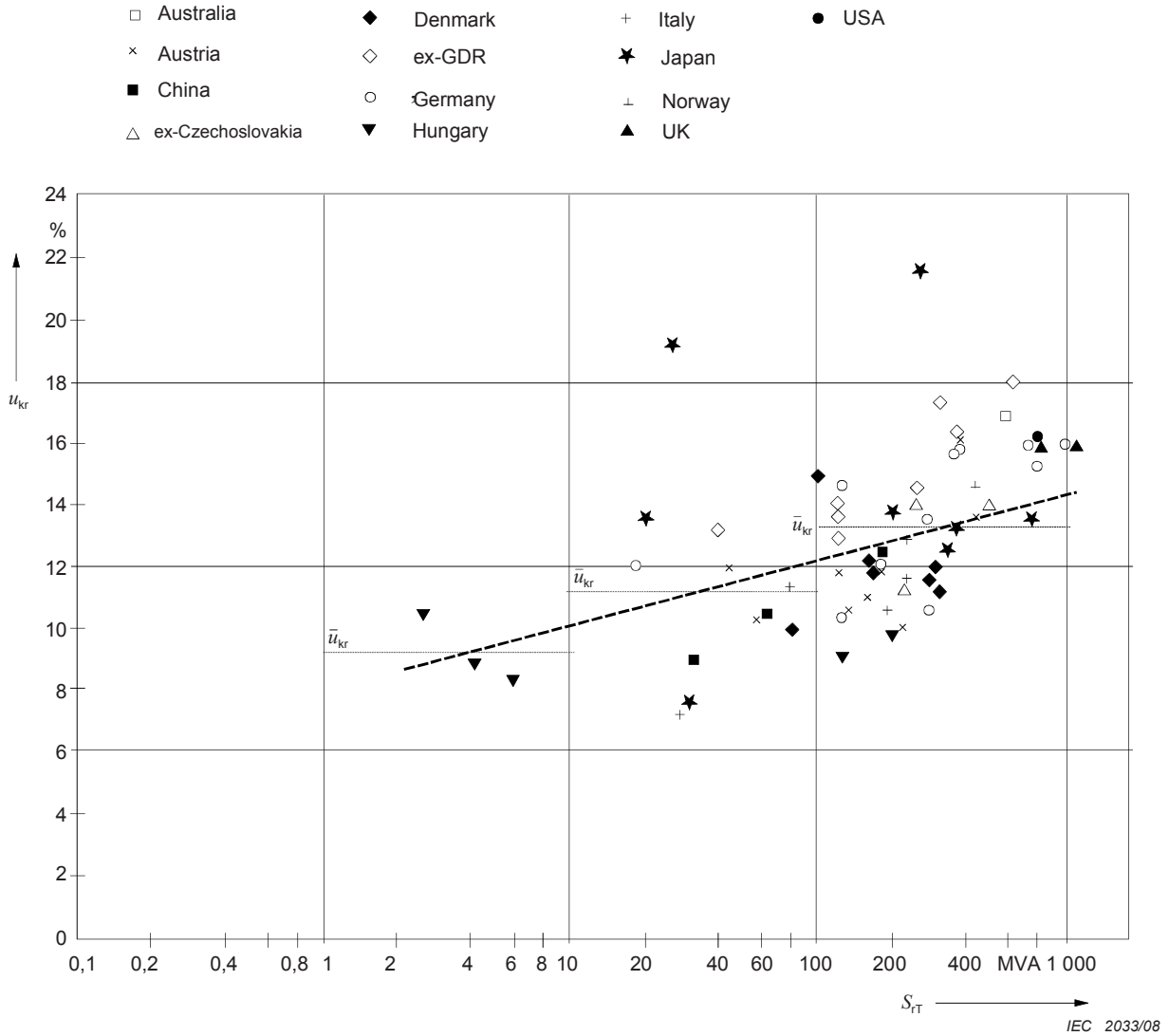

Figure 6 – Rated short-circuit voltages u_{kr} of network transformers

2.4 Data of typical overhead lines, single and double circuits

The positive sequence impedance may be calculated from conductor data such as cross section and conductor centre-distances (see IEC 60909-0, 3.4, Equations (14) and (15)).

The effective resistance per unit length at a conductor temperature 20 °C is:

$$R_L' = \frac{\rho}{q_n} \quad (2)$$

At a conductor temperature of 20 °C for the calculation of the maximum short-circuit current, the following values may be used:

$$\text{Copper: } \rho = \frac{1}{54} \frac{\Omega \text{mm}^2}{\text{m}}; \quad \text{Aluminium: } \rho = \frac{1}{34} \frac{\Omega \text{mm}^2}{\text{m}}; \quad \text{Aluminium alloy: } \rho = \frac{1}{31} \frac{\Omega \text{mm}^2}{\text{m}};$$

In case of aluminium/steel conductors only the aluminium cross-section shall be used for q_n .

The following equations can be used for the calculation of the short-circuit impedances in the positive-sequence and the zero-sequence system of overhead lines with single conductors or bundled conductors with one or two three-phase a.c. circuits without or with earth wires.

Single circuit line (I)

Positive-sequence system impedance:

$$\underline{Z}'_{(1)} = \underline{Z}'_{(1)} = \frac{R_L'}{n} + j\omega \frac{\mu_0}{2\pi} \left(\frac{1}{4n} + \ln \frac{d}{r_B} \right) \quad (3)$$

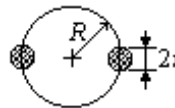

Example for a bundle conductor with two subconductors

n is the number of subconductors ($n = 1, 2, 3, 4, 6$), in case of $n = 1$ there is only one conductor, r is the radius of the subconductor, $d = \sqrt[3]{d_{L1L2}d_{L1L3}d_{L2L3}}$ is the geometric mean distance between the conductors, $r_B = \sqrt[n]{nrR^{n-1}}$ is the effective bundle radius with R as the radius of the circle on which the subconductors are placed according to the figure above.

Zero-sequence system impedance without earth wire:

$$\underline{Z}'_{(0)} = \frac{R_L'}{n} + 3\omega \frac{\mu_0}{8} + j\omega \frac{\mu_0}{2\pi} \left(\frac{1}{4n} + 3 \ln \frac{\delta}{\sqrt[3]{r_B d^2}} \right) \quad (4)$$

The zero-sequence system impedances in Figures 7 and 8 and in Table 5 are referred to an earth resistivity of $\rho = 100 \Omega \text{m}$ and therefore to an equivalent depth of current return of $\delta = 930 \text{m}$ (50 Hz) or $\delta = 850 \text{m}$ (60 Hz). For the calculation of δ see IEC 60909-3, Equation (36).

Zero-sequence impedance with one earth wire Q:

$$\underline{Z}'_{(0)Q} = \underline{Z}'_{(0)} - 3 \frac{\underline{Z}'_{QLE}{}^2}{\underline{Z}'_{QQE}} \quad (5)$$

with

$$\underline{Z}'_{QQE} = R_Q + \omega \frac{\mu_0}{8} + j\omega \frac{\mu_0}{2\pi} \left(\frac{\mu_{rQ}}{4} + \ln \frac{\delta}{r_Q} \right),$$

$$\underline{Z}'_{QLE} = \omega \frac{\mu_0}{8} + j\omega \frac{\mu_0}{2\pi} \ln \frac{\delta}{d_{QL}}, \quad \text{and} \quad d_{QL} = \sqrt[3]{d_{QL1}d_{QL2}d_{QL3}}$$

μ_{rQ} depends on the material and structure of the earth wire.

Zero-sequence impedance with two earth wires Q1 and Q2:

$$\underline{Z}'_{(0)} = \underline{Z}'_{(0)} - 3 \frac{\underline{Z}'_{Q1Q2LE} \underline{Z}'_{Q1Q2E}}{\underline{Z}'_{Q1Q2E}} \tag{6}$$

with

$$\underline{Z}'_{Q1Q2E} = \frac{R_Q}{2} + \omega \frac{\mu_0}{8} + j\omega \frac{\mu_0}{2\pi} \left(\frac{\mu_{rQ}}{8} + \ln \frac{\delta}{\sqrt{r_Q d_{Q1Q2}}} \right),$$

$$\underline{Z}'_{Q1Q2LE} = \omega \frac{\mu_0}{8} + j\omega \frac{\mu_0}{2\pi} \ln \frac{\delta}{\sqrt[6]{d_{Q1L1}d_{Q1L2}d_{Q1L3}d_{Q2L1}d_{Q2L2}d_{Q2L3}}},$$

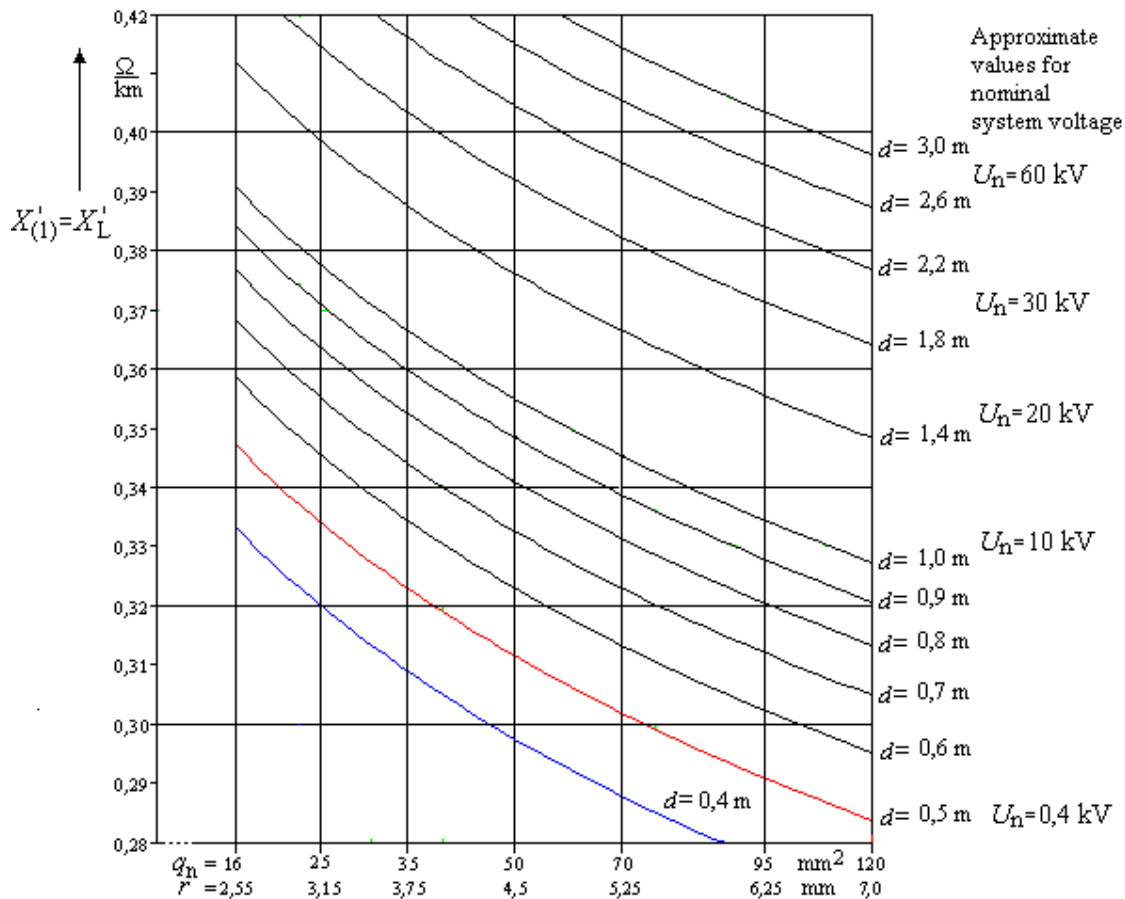

IEC 2034/08

NOTE In case of 60 Hz, the values shall be multiplied by 1,2.

Figure 7 – Positive-sequence reactance $X'_{(1)} = X'_L$ of low-voltage and medium-voltage overhead lines 50 Hz, Cu or Al, with one circuit according to Equation (15) of IEC 60909-0

Calculated values $X'_{(1)} = \omega \frac{\mu_0}{2\pi} \left(\frac{1}{4} + \ln \frac{d}{r} \right)$

with

$$d = \sqrt[3]{d_{L1L2}d_{L1L3}d_{L2L3}}$$

Double circuit line (II)

Positive-sequence impedance per circuit:

$$\underline{Z}_{(1)}^{\parallel} = \frac{R_L'}{n} + j\omega \frac{\mu_0}{2\pi} \left(\frac{1}{4n} + \ln \frac{d \times d_{mL1M2}}{r_B d_{mL1M1}} \right) \quad (7)$$

with

$$d_{mL1M1} = \sqrt[3]{d_{L1M1}d_{L2M2}d_{L3M3}} \quad \text{and} \quad d_{mL1M2} = \sqrt[3]{d_{L1M2}d_{L1M3}d_{L2M3}},$$

if the line conductors of both circuits are symmetrical to the tower, otherwise use:

$$d_{mL1M2} = \sqrt[6]{d_{L1M2}d_{L1M3}d_{L2M3}d_{L2M1}d_{L3M1}d_{L3M2}}$$

In many cases the quotient, d_{mL1M2} / d_{mL1M1} , has results in the neighbourhood of one and then the positive sequence impedance per circuit is $\underline{Z}_{(1)}^{\parallel} \approx \underline{Z}_{(1)}^{\prime}$.

Table 5 – Actual data of typical overhead lines 50 Hz and 60 Hz

No	Type of line/ number of circuits (Fig. 9)	Voltage	Conductors/ subcon- ductors number material q_n	Earth wire number material q_n	Geometric data (see 2.4 and Figure 8)					Positive- sequence impedance ^{a)} $Z'_{(1)} =$ $R'_{(1)} + jX'_{(1)}$	Zero- sequence impedance ^{a)} $Z'_{(0)} =$ $R'_{(0)} + jX'_{(0)}$	National Commit- tee		
					r	d	d_{mL1M2}	d_{Q1Q2}	d_{QL}				Ω/km	Ω/km
					r_B	d_{LM}	d_{mL1M1}							
kV	mm ²	mm ²	mm	m	m	m	m	m	Ω/km	Ω/km				
1	A/1	0,40	1 × Al 95	(PEN)	6,25	0,6	-	-	-	0,31+j0,302	0,63+j0,941	Austria		
2	B/1	20	1 × Cu 25	-	3,15	1,23	-	-	-	0,746+j0,396	0,854+j1,643	Italy		
3	D/1	66	1 × Al/St Condor	Al/St 25	13,86	3,77	-	3,0	4,9	0,072+j0,365	0,410+j0,882	Norway		
4	F/1	110	1 × Al/St 240/40	1 × St 50	10,95	4,06	-	-	10,8	0,119+j0,387	0,309+j1,382	Germany		
5	C/1	110	1 × Al/St 185/25	1 × St 50	9,2	4,61	-	-	4,33	0,156+j0,395	0,370+j1,34	Bulgaria		
6	C/1	132	1 × Al/St 525/68	1 × Al/St 138/68	15,8	5,81	-	-	12	0,061+j0,387	0,202+j0,931	Denmark		
7	E/1	220	1 × Al/St 291/37,2	2 × St 50	11,75	6,39	-	5,8	6,99	0,108+j0,411	0,352+j1,242	China		
8	C/ ^{b)}	220	1 × Al/St 400/51	1 × St 70	13,75	8,0	-	-	11,6	0,075+j0,420	0,250+j1,340	ex-USSR		
9	G/2	220	2 × Al/St 240/40	1 × Al/St 240/40	10,95 66,2	6,24 15,3	15,8 14,4	-	16,3	0,06+j0,299	0,273+j1,479	Germany		
10	K/2	275	4 × Al/St 610/79,4	1 × AS 160	17,1 304	9,85 13,74	16,39 12,60	13,0	16,84	0,015+j0,239	0,111+j1,708	Japan (50 Hz)		
11	K/2	380	2 × Al/St 680/85 ^{c)}	1 × Al/St 240/40	18,0 48,9	11,5 19,1	19,2 23,2	-	21,6	0,0215+j0,303	0,243+j1,400	Austria		
12	D/1	500	4 × Al/St 291/37,2	2 × Al/St 120/22	11,75 197,3	17,64	-	24,0	18,08	0,031+j0,286	0,233+j0,715	Australia		
13	K/2	500	4 × Al/St 814 / 56	2 × Al/St 150 / 87	38,4 287,3	15,13	25,23 19,38	20,4	26,92	0,009+j0,304	0,356+j1,224	Japan (60 Hz)		

a) Impedances per circuit and resistances at a temperature of 20 °C.
 b) Special design. Two separate lines in one single right-of-way.
 c) Since 2006, a new configuration of conductors is typical: 3 × Al/St 635/117.

Zero-sequence impedance with one earth wire Q per circuit:

$$Z'_{-(0)} = Z'_{-(0)} + 3Z'_{-LME} - 6 \frac{Z'^2_{-QLE}}{Z'_{-QQE}} \tag{8}$$

with

$$Z'_{-LME} = \omega \frac{\mu_0}{8} + j\omega \frac{\mu_0}{2\pi} \ln \frac{d}{d_{LM}}$$

$$d_{LM} = \sqrt[3]{d_{mL1M1}d_{mL1M2}^2} ; d_{mL1M1} = \sqrt[3]{d_{L1M1}d_{L2M2}d_{L3M3}} ; d_{mL1M2} = \sqrt[3]{d_{L1M2}d_{L1M3}d_{L2M3}} ,$$

if the line conductors of both circuits are symmetrical to the tower.

For \underline{Z}'_{QQE} and \underline{Z}'_{QLE} see the information following Equation (5).

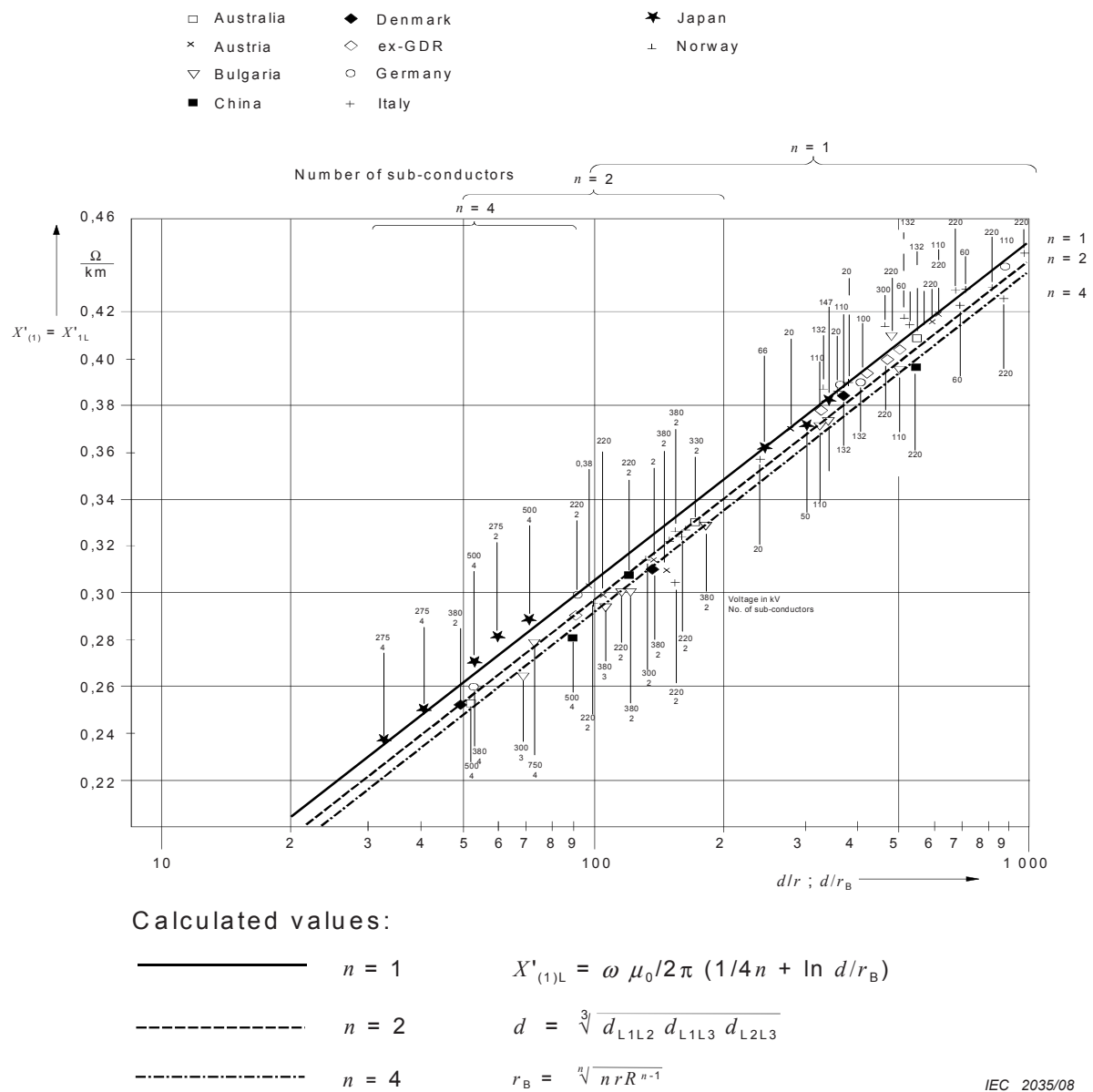
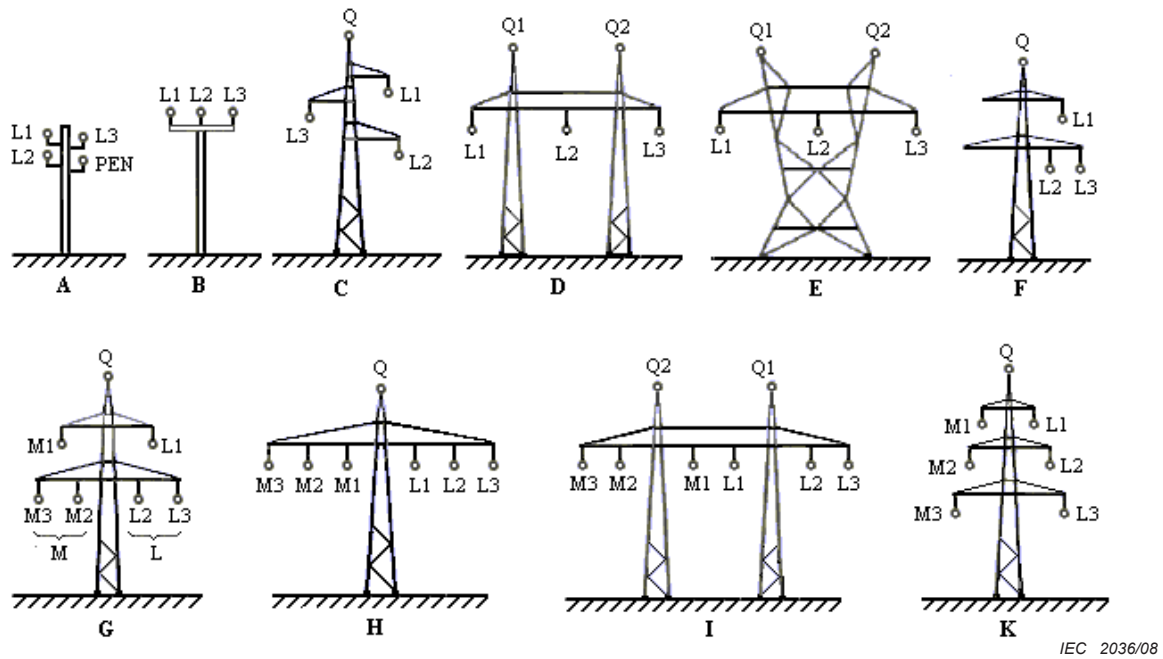

Figure 8 – Positive-sequence reactance $X'_{(1)} = X'_{1L}$ of overhead lines 50 Hz (60 Hz-values converted to 50 Hz)

Zero-sequence impedance with two earth wires Q1 and Q2:

$$\underline{Z}'_{(0)}{}^{IIQ1Q2} = \underline{Z}'_{(0)} + 3\underline{Z}'_{LME} - 6 \frac{\underline{Z}'_{Q1Q2LE}}{\underline{Z}'_{Q1Q2E}} \quad (9)$$

For \underline{Z}'_{LME} , see the information following Equation (8) respectively for \underline{Z}'_{Q1Q2E} and \underline{Z}'_{Q1Q2LE} , see the information following Equation (6).



Key

A to F: Single-circuit lines

G to K: Double-circuit lines

Figure 9 – Type of overhead lines

2.5 Data of typical high-voltage, medium-voltage and low-voltage cables

The impedances of high-, medium and low-voltage cables depend on national techniques and standards and may be taken from textbooks or the manufacturers' data. In Table 6 collected characteristic data of 50-Hz cables are given.

Table 6 – Actual data of typical electric cables

No	Rated voltage U_r a)	Conductors		Cross section and type b)	Type c)	No. of cores d)	Sheath (shield)		Positive-sequence impedance $Z'_{(1)} = R'_{(1)} + jX'_{(1)}$ f)	Current return g)	Zero-sequence impedance $Z'_{(0)} = R'_{(0)} + jX'_{(0)}$ f)	Country
		Number	Material				Type e)	Material				
	kV	-	-	mm ²	-	-	-	-	Ω/km	-	Ω/km	
1	0,6/1	4	Al	240/120 rST	NR	3½	-	-	0,129+j0,04	4 th +E	4,2R'_{(1)} + j4,6X'_{(1)}	ex-Czechosl.
2	6/10	3×1	Cu	120 rST	R ^{h)}	SC	W+T	Cu	0,16+j0,116	S+E	-	Hungary
3	10	3	Cu	240 rST	NR	TC	M	Pb	0,088+j0,069	S+E	+j0,242	China
4	22	3	Cu	120 rST	NR ⁱ⁾	TC	FW	Cu	0,153+j0,104	S+E	-	Norway
5	50	3×1	Al	500r	R	SC	W	Cu	0,084+j0,11	S+E	0,456+j0,156	Denmark
6	110	3×1	Cu	240 HO	R ^{j)}	SC	M	Pb/Al	0,079+j0,12	S+E	0,51+j0,30	Germany
7	132	3×1	Cu	220r HO	R	SC	M	Pb	0,084+j0,12	S	0,58+j0,061	Italy
8	275	3×1	Cu	1400sST	R	SC	M	Al	0,0131+j0,146	S+E	0,047+j0,047	Japan
9	330	3×1	Cu	1200s HO	R	SC	M	Al	0,0205+j0,188	S+E	0,0719+j0,0566	Australia
10	380	3×1	Cu	1200sST	R	SC	M	Al	0,018+j0,188	S	0,047+j0,070	Austria
a) Line-to-line voltage. b) r = round, HO = hollow, s = sector form, ST = stranded. c) R = radial field, NR = non-radial field. d) SC = single core, TC three-core cable. e) T = tapes; W = wires; M = metallic sheath.								f) AC resistance at 20°C. g) S in the sheath (shield), E in earth, 4 th in the fourth conductor. h) N2YSY. i) DKAB. j) Oil pressure.				

Table 7 gives the equations for the calculation of the positive-sequence and the zero-sequence impedance of single-core cables without and with metallic sheath or shield earthed at both ends. Case No. 2 is valid for low-voltage systems with four equal cores (N = PEN).

Table 7 – Equations for the positive-sequence and the zero-sequence impedance of cables

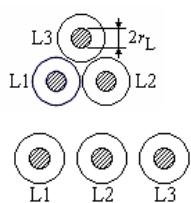
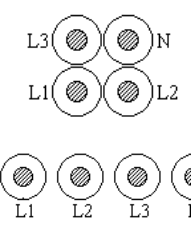
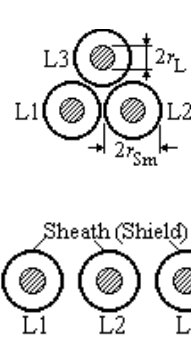
Case No	Cable configuration	Positive-sequence and zero-sequence impedance
1a 1b	<p>Cable without metallic sheath or shield</p> 	$\underline{Z}'_{(1)} = R'_L + j\omega \frac{\mu_0}{2\pi} \left(\frac{1}{4} + \ln \frac{d}{r_L} \right) \quad (10)$ $\underline{Z}'_{(0)} = R'_L + 3\omega \frac{\mu_0}{8} + j\omega \frac{\mu_0}{2\pi} \left(\frac{1}{4} + 3 \ln \frac{\delta}{\sqrt[3]{r_L d^2}} \right) \quad (11)$ <p>with $d = \sqrt[3]{d_{L1L2}d_{L1L3}d_{L2L3}}$ and δ from Equation (36) of IEC 60909-3</p>
2a 2b	<p>Cable without metallic sheath or shield</p> 	<p>Four equal single-core cables (low voltage)</p> $\underline{Z}'_{(1)N} = \underline{Z}'_{(1)} = R'_L + j\omega \frac{\mu_0}{2\pi} \left(\frac{1}{4} + \ln \frac{d}{r_L} \right) \quad (12)$ <p>Current return through the fourth conductor N</p> $\underline{Z}'_{(0)N} = 4R'_L + j4\omega \frac{\mu_0}{2\pi} \left(\frac{1}{4} + \ln \frac{\sqrt[3]{d_{LN}^3}}{r_L \sqrt{d}} \right) \quad (13)$ <p>Current return through the fourth conductor N and the earth E</p> $\underline{Z}'_{(0)NE} = \underline{Z}'_{(0)} - 3 \frac{\left(\omega \frac{\mu_0}{8} + j\omega \frac{\mu_0}{2\pi} \ln \frac{\delta}{d_{LN}} \right)^2}{R'_L + \omega \frac{\mu_0}{8} + j\omega \frac{\mu_0}{2\pi} \left(\frac{1}{4} + \ln \frac{\delta}{r_L} \right)} \quad (14)$ <p>with $\underline{Z}'_{(0)}$ from Equation (11) and $d_{LN} = \sqrt[3]{d_{L1N}d_{L2N}d_{L3N}}$</p>
3a 3b	<p>Cable with metallic sheath (shield) S earthed at both ends</p> 	$\underline{Z}'_{(1)S} = \underline{Z}'_{(1)} + \frac{\left(\omega \frac{\mu_0}{2\pi} \ln \frac{d}{r_{Sm}} \right)^2}{R'_S + j\omega \frac{\mu_0}{2\pi} \ln \frac{d}{r_{Sm}}} \quad (15)$ <p>Current return through sheath (shield) and earth</p> $\underline{Z}'_{(0)SE} = \underline{Z}'_{(0)} - \frac{\left(3\omega \frac{\mu_0}{8} + j3\omega \frac{\mu_0}{2\pi} \ln \frac{\delta}{\sqrt[3]{r_{Sm} d^2}} \right)^2}{R'_S + 3\omega \frac{\mu_0}{8} + j3\omega \frac{\mu_0}{2\pi} \ln \frac{\delta}{\sqrt[3]{r_{Sm} d^2}}} \quad (16)$ <p>with $\underline{Z}'_{(1)}$ from Equation (10), $\underline{Z}'_{(0)}$ from Equation (11) and the medium radius $r_{Sm} = 0,5(r_{Si} + r_{Sa})$ of the sheath or the shield.</p> $r_{-3} = \frac{R'_S}{R'_S + 3\omega \frac{\mu_0}{8} + j3\omega \frac{\mu_0}{2\pi} \ln \frac{\delta}{\sqrt[3]{r_{Sm} d^2}}} \quad (17)$

High-voltage cables

Case No. 3 in Table 7, with Equations (15) and (16), is valid for three single-core high-voltage cables, for instance 64 kV/110 kV (Figure 10), with a metallic sheath or shield connected and earthed at both ends. As well in the case of a positive-sequence current system as in the case of a zero-sequence current system, currents are flowing through the sheaths or shields of the three cables. In this case therefore the calculation of the reduction factor (see IEC 60909-3) has to take care of the three sheaths (or shields), too.

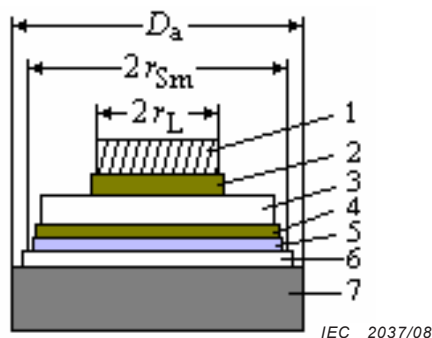

Key

- 1 al-conductor, stranded
- 2 conductor screen: semi-conducting XLPE
- 3 insulation: XLPE, 18 mm
- 4 insulation screen: extruded semi-conducting XLPE
- 5 bedding: semi-conducting tape
- 6 metallic sheath: lead alloy
- 7 outer sheath: PE black

Figure 10 – Single-core cable 64 kV / 110 kV with lead sheath [4]²

The following Table 8a gives the data and the results calculated with Equations (15) and (16) of Table 7 (Case No.3a: triangular configuration) for three high-voltage single-core cables with lead sheath for 64/110 kV ($U_m = 123$ kV) 2XK2Y. Data are given from the manufacturer [4]. Table 8b deals with the flat configuration of the cables. In this case it is necessary to calculate arithmetic medium values.

² Figures in square brackets refer to the Bibliography.

**Table 8 – Single-core cables 64/110 kV, 2XK2Y,
3 × 1 × 240 ... 1 200 mm, Cu with lead sheath**

a) in triangular configuration

Zero-sequence impedance $\underline{Z}'_{(0)SE} = R'_{(0)SE} + jX'_{(0)SE}$ in case of current return through the sheath and the earth, $f = 50$ Hz, $\rho = 100 \Omega\text{m}$,

q_n	r_L	q_S a)	r_{Sm} a)	D_a	d b)	R'_L	R'_S	 Equation (15) $\underline{Z}'_{(1)S} = R'_{(1)S} + jX'_{(1)S}$	$\frac{R'_{(0)SE}}{R'_{(1)S}}$ c)	$\frac{X'_{(0)SE}}{X'_{(1)S}}$ c)	r_3 d)
mm ²	mm	mm ²	mm	mm	mm	Ω/km	Ω/km	Ω/km	-	-	-
240	9,3	440	33,3	72	76,3	0,0754	0,473	0,0811+j 0,1473	6,30	1,40	0,245
300	10,3	460	34,9	74	78,4	0,0601	0,453	0,0657+j 0,1426	7,29	1,36	0,236
400	11,9	480	36,4	77	81,6	0,0470	0,434	0,0528+j 0,1360	8,53	1,33	0,228
500	13,8	520	37,6	80	84,8	0,0366	0,401	0,0430+j 0,1290	9,60	1,24	0,213
630	15,6	550	39,8	85	90,1	0,0283	0,379	0,0351+j 0,1250	10,98	1,19	0,203
800	17,35	580	42,0	88	93,3	0,0221	0,359	0,0290+j 0,1204	12,50	1,15	0,193
1000	19,40	640	44,3	93	98,6	0,0176	0,326	0,0252+j 0,1167	13,06	1,06	0,177
1200	21,7	670	46,4	98	104	0,0151	0,311	0,0232+j 0,1128	13,52	1,02	0,170

- a) $q_S = 2\pi r_{Sm} d_S$ with d_S thickness of the lead sheath.
- b) $d \approx 1,06 D_a$ in case of a triangle configuration.
- c) $\underline{Z}'_{(0)SE}$ according to Equation (16).
- d) Reduction factor of the three sheaths of the single-core cables, see Equation (17).

b) in flat configuration

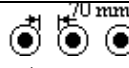
q_n	r_L	q_S a)	r_{Sm} a)	D_a	d b)	R'_L	R'_S	 Equ. (15) $\underline{Z}'_{(1)S} = R'_{(1)S} + jX'_{(1)S}$	$\frac{R'_{(0)SE}}{R'_{(1)S}}$ c)	$\frac{X'_{(0)SE}}{X'_{(1)S}}$ c)	r_3 d)
mm ²	mm	mm ²	mm	mm	mm	Ω/km	Ω/km	Ω/km	-	-	-
240	9,3	440	33,3	72	178,9	0,0754	0,473	0,0990+j 0,2015	5,12	1,047	0,259
300	10,3	460	34,9	74	181,4	0,0601	0,453	0,0838+j 0,1959	5,68	1,016	0,249
400	11,9	480	36,4	77	185,2	0,0470	0,434	0,0711+j 0,1882	6,29	0,982	0,240
500	13,8	520	37,6	80	189,0	0,0366	0,401	0,0623+j 0,1801	6,59	0,911	0,224
630	15,6	550	39,8	85	195,3	0,0283	0,379	0,0547+j 0,1745	7,01	0,870	0,213
800	17,35	580	42,0	88	199,1	0,0221	0,359	0,0487+j 0,1690	7,39	0,836	0,203
1000	19,40	640	44,3	93	205,4	0,0176	0,326	0,0461+j 0,1836	7,10	0,769	0,186
1200	21,7	670	46,4	98	211,7	0,0151	0,311	0,0443+j 0,1588	7,02	0,738	0,179

- a) $q_S = 2\pi r_{Sm} d_S$ with d_S thickness of the lead sheath.
- b) $d = (D_a + 70\text{mm}) \cdot \sqrt[3]{2}$ in case of a flat configuration.
- c) $\underline{Z}'_{(0)SE}$ according to Equation (16).
- d) Reduction factor of the three sheaths of the single-core cables, see Equation (17).

Medium voltage cables

Calculated results found with Equations (15) to (17) are given for single-core cables according to the German Standards (N) with copper or aluminium (A) conductors, a cross-linked polyethylene (XLPE) insulation (2X), a screen of copper wires and copper tape, helically applied (S), and a polyethylene sheath (2Y). The following tables give the positive-sequence and the zero-sequence impedance in case of current return through the shield (S) and the earth (E) for selected cross sections of 6-/10-kV-and 12-/20-kV-cables $3 \times 1 \times q_n$ and in addition the reduction factor $r_3 = |I_E / 3I_0|$, taking into account the shield of all three single-core cables.

Table 9 – 10-kV-cables N2XS2Y

a) in triangular configuration (Table 7, Case No. 3a)

q_n a)d)	D_a b)d)	r_L	r_{Sm} d)	R'_L d)	R'_S c)	$Z'_{(1)S} = R'_{(1)S} + jX'_{(1)S}$	$\frac{R'_{(0)SE}}{R'_{(1)S}}$	$\frac{X'_{(0)SE}}{X'_{(1)S}}$	r_3
mm ²	mm	mm	mm	Ω/km	Ω/km	Ω/km	-	-	-
95/16	29	6,3	23,9	0,193	1,12	0,193+j 0,115	5,29	4,80	0,48
120/16	30	7,1	24,9	0,153	1,12	0,153+j 0,109	6,39	5,00	0,48
150/25	32	7,95	26,9	0,124	0,714	0,124+j 0,106	5,96	2,93	0,34
185/25	33	8,82	27,9	0,0991	0,714	0,0991+j 0,102	7,20	3,03	0,34
240/25	36	10,05	30,9	0,0754	0,714	0,0765+j 0,099	9,13	3,11	0,34
300/25	39	11,24	33,9	0,0601	0,714	0,0603+j 0,097	11,17	3,17	0,34

a) rST, see Table 6 .

b) $d = 1,05 \times D_a$

c) $\kappa = 56 \text{ Sm/mm}^2$.

d) Data q_n, R'_L, D_a, r_{Sm} according to [3] and [4].

b) in flat configuration (Table 7, Case No. 3b)

q_n a)d)	D_a b)d)	r_L	r_{Sm} d)	R'_L d)	R'_S c)	$Z'_{(1)S} = R'_{(1)S} + jX'_{(1)S}$	$\frac{R'_{(0)SE}}{R'_{(1)S}}$	$\frac{X'_{(0)SE}}{X'_{(1)S}}$	r_3
mm ²	mm	mm	mm	Ω/km	Ω/km	Ω/km	-	-	-
95/16	29	6,3	23,9	0,193	1,12	0,203+j 0,202	4,84	2,80	0,51
120/16	30	7,1	24,9	0,153	1,12	0,162+j 0,196	5,79	2,87	0,51
150/25	32	7,95	26,9	0,124	0,714	0,137+j 0,189	5,28	1,72	0,36
185/25	33	8,82	27,9	0,0991	0,714	0,112+j 0,183	6,25	1,75	0,36
240/25	36	10,05	30,9	0,0754	0,714	0,0871+j 0,177	7,76	1,81	0,36
300/25	39	11,24	33,9	0,0601	0,714	0,0709+j 0,172	9,31	1,86	0,37

a) rST, see Table 6.

b) $d = (D_a + 70 \text{ mm}) \times \sqrt[3]{2}$.

c) $\kappa = 56 \text{ Sm/mm}^2$.

d) Data q_n, R'_L, D_a, r_{Sm} according to [3] and [4].

Table 10 – 20-kV-cables N2XS2Y

a) in triangular configuration (Table 7, Case No. 3a)

q_n a)d)	D_a b)d)	r_L	r_{Sm} d)	R'_L d)	R'_S c)	$\underline{Z}'_{(1)S} = R'_{(1)S} + jX'_{(1)S}$	$\frac{R'_{(0)SE}}{R'_{(1)S}}$	$\frac{X'_{(0)SE}}{X'_{(1)S}}$	r_3
mm ²	mm	mm	mm	Ω/km	Ω/km	Ω/km	-	-	-
95/16	33	6,3	28	0,196	1,12	0,196+j 0,123	5,19	4,58	0,48
120/16	34	7,1	29	0,156	1,12	0,156+j 0,117	6,25	4,76	0,49
150/25	36	7,95	31	0,129	0,714	0,129+j 0,114	5,76	2,84	0,34
185/25	38	8,82	33	0,104	0,714	0,104+j 0,111	6,89	2,90	0,34
240/25	40	10,05	35	0,081	0,714	0,0812+j 0,106	8,55	3,00	0,34
300/25	43	11,24	38	0,0662	0,714	0,0664+j 0,103	10,22	3,07	0,34

a) rST, see Table 6.
b) $d = 1,05 \times D_a$.
c) $\kappa = 56 \text{ Sm/mm}^2$.
d) Data q_n , R'_L , Δ_a , r_{Sm} according to [3] and [4].

b) in flat configuration (Table 7, Case No. 3b)

q_n a)d)	D_a b)d)	r_L	r_{Sm} d)	R'_L d)	R'_S c)	$\underline{Z}'_{(1)S} = R'_{(1)S} + jX'_{(1)S}$	$\frac{R'_{(0)SE}}{R'_{(1)S}}$	$\frac{X'_{(0)SE}}{X'_{(1)S}}$	r_3
mm ²	mm	mm	mm	Ω/km	Ω/km	Ω/km	-	-	-
95/16	33	6,3	28	0,196	1,12	0,204+j 0,206	4,79	2,81	0,51
120/16	34	7,1	29	0,156	1,12	0,164+j 0,199	5,73	2,88	0,52
150/25	36	7,95	31	0,129	0,714	0,141+j 0,193	5,18	1,74	0,36
185/25	38	8,82	33	0,104	0,714	0,115+j 0,188	6,11	1,77	0,37
240/25	40	10,05	35	0,081	0,714	0,091+j 0,181	7,43	1,82	0,37
300/25	43	11,24	38	0,0662	0,714	0,0757+j 0,174	8,75	1,87	0,37

a) rST, see Table 6.
b) $d = (D_a + 70 \text{ mm}) \times \sqrt[3]{2}$.
c) $\kappa = 56 \text{ Sm/mm}^2$.
d) Data q_n , R'_L , Δ_a , r_{Sm} according to [3] and [4].

Low-voltage cables

Results for Case No. 2a in Table 7 are given as an example in Table 11 in the case of four low-voltage (0,6/1 kV) single-core cables $NYN\ 4 \times 1 \times q_n$

Table 11 – Positive-sequence and zero-sequence impedance of four low-voltage single-core cables $NYN\ 4 \times 1 \times q_n$... (Case No. 2a in Table 7)

with

$R'_{(0)N} / R'_{(1)N}$, $X'_{(0)N} / X'_{(1)N}$ in case of current return through the fourth conductor N and $R'_{(0)NE} / R'_{(1)N}$, $X'_{(0)NE} / X'_{(1)N}$ in case of current return through the fourth conductor N and the earth

Cross section q_n a)	r_L	R'_L	D_a b)	 Equation (12) $Z'_{(1)N} = R'_{(1)N} + jX'_{(1)N}$	$\frac{R'_{(0)N}}{R'_{(1)N}}$ c)	$\frac{X'_{(0)N}}{X'_{(1)N}}$ c)	$\frac{R'_{(0)NE}}{R'_{(1)N}}$ d)	$\frac{X'_{(0)NE}}{X'_{(1)N}}$ d)	r e)
mm ²	mm	Ω/km	mm	Ω/km	-	-	-	-	-
4×1×10 r	1,78	1,83	12	1,830+j0,143	4	4	1,41	13,02	0,89
4×1×16 r	2,26	1,15	13	1,150+j0,133	4	4	1,77	11,59	0,79
4×1×25 rST	3,24	0,727	15	0,727+j0,119	4	4	2,22	9,62	0,66
4×1×35 rST	3,82	0,524	16	0,524+j0,113	4	4	2,55	7,88	0,55
4×1×50 rST	4,54	0,382	18	0,387+j0,110	4	4	2,78	6,42	0,45
4×1×70 rST	5,40	0,268	19	0,268+j0,102	4	4	3,01	5,27	0,34
4×1×95 rST	6,30	0,193	21	0,193+j0,099	4	4	3,13	4,56	0,27
4×1×120 rST	7,10	0,153	23	0,153+j0,097	4	4	3,19	4,23	0,23
4×1×150 rST	7,95	0,124	26	0,124+j0,097	4	4	3,22	4,01	0,21
4×1×185 rST	8,80	0,0991	28	0,099+j0,096	4	4	3,25	3,87	0,18
4×1×240 rST	10,05	0,0754	31	0,075+j0,094	4	4	3,28	3,77	0,16
4×1×300 rST	11,25	0,0601	33	0,060+j0,091	4	4	3,32	3,72	0,15

- a) See Table 6;
- b) $D_a = D_{amax}$, outer diameter of the single-core cable, $d = d_{LN} = \sqrt[6]{2} D_a$.
- c) $Z'_{(0)N}$ according to Equation (13).
- d) $Z'_{(0)NE}$ according to Equation (14).
- e) See Equation (21).

The results $R'_{(0)NE} / R'_{(1)N}$, $X'_{(0)NE} / X'_{(1)N}$ given in Table 11, are valid for an earth penetration depth of $\delta = 931$ m and a cable length of at least 1_000 m. In case of short cables ($l < 1_000$ m $\approx \delta$) the results, $R'_{(0)NE} / R'_{(1)N}$, $X'_{(0)NE} / X'_{(1)N}$ are smaller than those given in Table 11. In this case δ should be replaced by the expression $d_E = (2/e)l_C e^{-l_C/(e\delta)}$ with l_C as the cable length ($l_C < \delta$) and $e = 2,718$ and $\omega\mu_0/8$ should be replaced by $0,75(\omega\mu_0/8)d_E/\delta$ [2] and [5].

Low-voltage cable according to German Standards (N) [3]:

Type A:

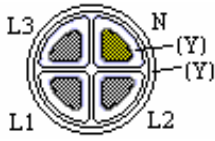

Cable with copper or aluminium (A) conductors (example: four-core cable), insulation of thermoplastic material based on PVC (Y) and a protective covering in the form of a sheath of thermoplastic material based on PVC (Y): N(A)YY

$$\underline{Z}'_{(1)N} = R'_L + j\omega \frac{\mu_0}{2\pi} \left(\frac{1}{4} + \ln \frac{d}{r_L} \right) \quad \text{with} \quad d = \sqrt[3]{d_{L1}d_{L2}d_{L1L3}d_{L2L3}} \quad (18)$$

Four-core cable N(A)YY:

Current return through the fourth conductor N (with full cross section):

$$\underline{Z}'_{(0)N} = 4R'_L + j4\omega \frac{\mu_0}{2\pi} \left(\frac{1}{4} + \ln \frac{d}{r_L} \right) = 4\underline{Z}'_{(1)N} \quad (19)$$

Current return through the fourth conductor N and the earth E:

$$\underline{Z}'_{(0)NE} = R'_L + 3\omega \frac{\mu_0}{8} + j\omega \frac{\mu_0}{2\pi} \left(\frac{1}{4} + 3 \ln \frac{\delta}{\sqrt[3]{r_L d^2}} \right) - 3 \frac{\left(\omega \frac{\mu_0}{8} + j\omega \frac{\mu_0}{2\pi} \ln \frac{\delta}{d} \right)^2}{R'_L + \omega \frac{\mu_0}{8} + j\omega \frac{\mu_0}{2\pi} \left(\frac{1}{4} + \ln \frac{\delta}{r_L} \right)} \quad (20)$$

Reduction factor (Current through earth: $\underline{I}_E = r_- 3\underline{I}_{(0)}$, see IEC 60909-3):

$$r_- = 1 - \frac{\omega \frac{\mu_0}{8} + j\omega \frac{\mu_0}{2\pi} \ln \frac{\delta}{d}}{R'_L + \omega \frac{\mu_0}{8} + j\omega \frac{\mu_0}{2\pi} \left(\frac{1}{4} + \ln \frac{\delta}{r_L} \right)} \quad (21)$$

Table 12 – Low-voltage cable NYY

a) with four copper conductors

q_n a)	r_L	R'_L b)	d_{ls} c)	d d)	D_a e)	$Z'_{(1)N}$	$\frac{R'_{(0)N}}{R'_{(1)N}}$	$\frac{X'_{(0)N}}{X'_{(1)N}}$	$\frac{R'_{(0)NE}}{R'_{(1)N}}$	$\frac{X'_{(0)NE}}{X'_{(1)N}}$	r
mm ²	mm	Ω/km	mm	mm	mm	Ω/km	-	-	-	-	-
4 × 10 r	1,78	1,83	1,0	6,3	20	1,830+j0,0951	4	4	1,46	20,07	0,89
4 × 16 r	2,26	1,15	1,0	7,3	22	1,150+j0,0894	4	4	1,85	17,30	0,79
4 × 25 rST	3,24	0,727	1,2	10,2	28	0,727+j0,0878	4	4	2,33	12,75	0,66
4 × 35 sST	3,82	0,524	1,2	11,5	26	0,524+j0,0850	4	4	2,66	9,94	0,54
4 × 50 sST	4,54	0,387	1,4	13,6	30	0,387+j0,0846	4	4	2,91	7,66	0,44
4 × 70 sST	5,40	0,268	1,4	15,6	33	0,268+j0,0824	4	4	3,12	5,89	0,36
4 × 95 sST	6,30	0,193	1,6	18,1	38	0,193+j0,0820	4	4	3,24	4,89	0,26
4 × 120 sST	7,10	0,153	1,6	19,9	42	0,153+j0,0805	4	4	3,29	4,48	0,22
4 × 150 sST	7,95	0,124	1,8	22,3	46	0,124+j0,0805	4	4	3,32	4,20	0,19
4 × 185 sST	8,80	0,0991	2,0	24,6	53	0,0991+j0,0803	4	4	3,35	4,01	0,17
4 × 240 sST	10,05	0,0754	2,2	27,9	59	0,0754+j0,0799	4	4	3,37	3,86	0,15
4 × 300 sST	11,25	0,0601	2,4	31,2	65	0,0601+j0,0798	4	4	3,38	3,79	0,14

a) See Table 6.

b) Resistance at 20 °C.

c) Thickness of insulation.

d) $d = \sqrt[3]{d_{L1L2} d_{L1L3} d_{L2L3}}$

e) Outer diameter of the four-core cable.

b) with four aluminium conductors

q_n	r_L	R'_L a)	d b)	D_a c)	$Z'_{(1)N}$	$\frac{R'_{(0)N}}{R'_{(1)N}}$	$\frac{X'_{(0)N}}{X'_{(1)N}}$	$\frac{R'_{(0)NE}}{R'_{(1)N}}$	$\frac{X'_{(0)NE}}{X'_{(1)N}}$	r
mm ²	mm	Ω/km	mm	mm	Ω/km	-	-	-	-	-
4 × 35r	3,34	0,868	10,2	28	0,868+j 0,0859	4	4	2,13	14,87	0,72
4 × 50r	4,00	0,641	12,0	30	0,641+j 0,0847	4	4	2,45	11,85	0,62
4 × 70r	4,72	0,443	13,6	34	0,443+j 0,0822	4	4	2,81	8,80	0,49
4 × 95r	5,50	0,320	15,8	38	0,320+j 0,0820	4	4	3,03	6,72	0,39
4 × 120r	6,18	0,253	17,3	42	0,253+j 0,0804	4	4	3,15	5,75	0,32
4 × 150r	6,91	0,206	19,3	46	0,206+j 0,0802	4	4	3,22	5,10	0,28
4 × 185r	7,67	0,164	21,5	50	0,164+j 0,0805	4	4	3,27	4,59	0,23

a) Resistance at 20 °C.

b) $d = \sqrt[3]{d_{L1L2} d_{L1L3} d_{L2L3}}$

c) Outer diameter of the four-core cable.

Three-and-a-half-core cable NYY:

$$\underline{Z}'_{(1)N} = R'_L + j\omega \frac{\mu_0}{2\pi} \left(\frac{1}{4} + \ln \frac{d}{r_L} \right) \quad [\text{see Equation (18)}] \quad (22)$$

Current return through the fourth conductor N (with reduced cross section):

$$\underline{Z}'_{(0)N} = R'_L + 3R'_N + j\omega \frac{\mu_0}{2\pi} \left(1 + 4 \ln \frac{\sqrt{d_{LN}^3}}{\sqrt[4]{r_L r_N^3} \sqrt{d}} \right) \quad \text{with} \quad d_{LN} = \sqrt[3]{d_{L1N} d_{L2N} d_{L3N}} \quad (23)$$

Current return through the fourth conductor N (with reduced cross section) and the earth E:

$$\underline{Z}'_{(0)NE} = R'_L + 3\omega \frac{\mu_0}{8} + j\omega \frac{\mu_0}{2\pi} \left(\frac{1}{4} + 3 \ln \frac{\delta}{\sqrt[3]{r_L d^2}} \right) - 3 \frac{\left(\omega \frac{\mu_0}{8} + j\omega \frac{\mu_0}{2\pi} \ln \frac{\delta}{d_{LN}} \right)^2}{R'_N + \omega \frac{\mu_0}{8} + j\omega \frac{\mu_0}{2\pi} \left(\frac{1}{4} + \ln \frac{\delta}{r_N} \right)} \quad (24)$$

Reduction factor:

$$\underline{r} = 1 - \frac{\omega \frac{\mu_0}{8} + j\omega \frac{\mu_0}{2\pi} \ln \frac{\delta}{d_{LN}}}{R'_N + \omega \frac{\mu_0}{8} + j\omega \frac{\mu_0}{2\pi} \left(\frac{1}{4} + \ln \frac{\delta}{r_N} \right)} \quad (25)$$

Table 13 – Low-voltage cable NYY with three and a half copper conductors

q_n	r_L	R'_L	r_N	R'_N	d	$\underline{Z}'_{(1)N}$	$\frac{R'_{(0)N}}{R'_{(1)N}}$	$\frac{X'_{(0)N}}{X'_{(1)N}}$	$\frac{R'_{(0)NE}}{R'_{(1)N}}$	$\frac{X'_{(0)NE}}{X'_{(1)N}}$	r
mm ²	mm	Ω/km	mm	Ω/km	mm	Ω/km	-	-	-	-	-
3×25/16	3,24	0,727	2,26	1,15	9,93	0,727+j 0,086	5,75	4,79	2,29	17,67	0,79
3×35/16	3,82	0,524	2,26	1,15	11,0	0,524+j 0,082	7,58	5,21	2,76	18,42	0,79
3×50/25	4,54	0,387	3,24	0,727	13,2	0,387+j 0,083	6,64	4,77	3,39	13,47	0,66
3×70/35	5,40	0,268	3,34	0,524	15,0	0,268+j 0,080	6,87	5,14	4,07	10,72	0,54
3×95/50	6,30	0,193	4,00	0,387	17,4	0,193+j 0,080	7,02	5,08	4,61	8,44	0,44
3×120/70	7,10	0,153	5,40	0,268	19,3	0,153+j 0,079	6,26	4,66	4,58	6,42	0,34
3×150/70	7,95	0,124	5,40	0,268	21,2	0,124+j 0,078	7,48	4,94	5,35	6,61	0,34
3×185/95	8,80	0,0991	6,30	0,193	23,7	0,099+j 0,078	6,84	4,81	5,15	5,51	0,27
3×240/120	10,05	0,0754	7,10	0,153	26,7	0,075+j 0,077	7,09	4,85	5,42	5,12	0,23
3×300/150	11,25	0,0601	7,90	0,124	29,8	0,060+j 0,077	7,19	4,87	5,55	4,86	0,21

Type B:

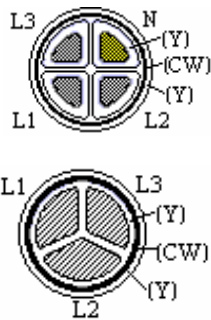

Cable with four or three copper or aluminium (A) conductors, insulation of thermoplastic material based on PVC (Y), concentric copper conductor, helically applied (CW), and a sheath of thermoplastic material based on PVC (Y): N(A)YCWY

Cable with four conductors NYCWY:

$$\underline{Z}'_{(1)NS} = R'_L + j\omega \frac{\mu_0}{2\pi} \left(\frac{1}{4} + \ln \frac{d}{r_L} \right) \quad \text{[(see Equation (18))]} \quad (26)$$

Current return through the fourth conductor N and the concentric copper conductor S:

$$\underline{Z}'_{(0)NS} = R'_L + j\omega \frac{\mu_0}{2\pi} \left(\frac{1}{4} + 3 \ln \frac{d_{LN}}{\sqrt[3]{r_L d^2}} \right) + 3 \left(R'_N + j\omega \frac{\mu_0}{2\pi} \left(\frac{1}{4} + \ln \frac{d_{LN}}{r_N} \right) \right) \frac{R'_S + j\omega \frac{\mu_0}{2\pi} \ln \frac{r_{Sm}}{d_{LN}}}{R'_N + R'_S + j\omega \frac{\mu_0}{2\pi} \left(\frac{1}{4} + \ln \frac{r_{Sm}}{r_N} \right)} \quad (27)$$

with the medium radius $r_{Sm} = 0,5(r_{Sa} + r_{Si})$.

The current distribution is:

$$I_N = 3I_{(0)} \cdot \frac{R'_S + j\omega \frac{\mu_0}{2\pi} \ln \frac{r_{Sm}}{d_{LN}}}{R'_N + R'_S + j\omega \frac{\mu_0}{2\pi} \left(\frac{1}{4} + \ln \frac{r_{Sm}}{r_N} \right)} \quad \text{and} \quad I_S = 3I_{(0)} \cdot \frac{R'_N + j\omega \frac{\mu_0}{2\pi} \ln \left(\frac{1}{4} + \ln \frac{d_{LN}}{r_N} \right)}{R'_N + R'_S + j\omega \frac{\mu_0}{2\pi} \left(\frac{1}{4} + \ln \frac{r_{Sm}}{r_N} \right)}$$

Current return through the fourth conductor N, the concentric copper conductor S and the earth E:

$$\underline{Z}'_{(0)NSE} = R'_L + 3\omega \frac{\mu_0}{8} + j\omega \frac{\mu_0}{2\pi} \left(\frac{1}{4} + 3 \ln \frac{\delta}{\sqrt[3]{r_L d^2}} \right) - \frac{1}{3} \cdot \frac{\underline{Z}'_{-N} \underline{Z}'_{-LS} + \underline{Z}'_{-S} \underline{Z}'_{-LN} - 2 \underline{Z}'_{-LN} \underline{Z}'_{-LS} \underline{Z}'_{-NS}}{\underline{Z}'_{-N} \underline{Z}'_{-S} - \underline{Z}'_{-NS}^2} \quad (28)$$

with

$$\underline{Z}'_{-N} = R'_N + \omega \frac{\mu_0}{8} + j\omega \frac{\mu_0}{2\pi} \left(\frac{1}{4} + \ln \frac{\delta}{r_N} \right); \quad \underline{Z}'_{-S} = R'_S + \omega \frac{\mu_0}{8} + j\omega \frac{\mu_0}{2\pi} \ln \frac{\delta}{r_{Sm}};$$

$$\underline{Z}'_{-L123N} = \underline{Z}'_{-LN} = 3\omega \frac{\mu_0}{8} + j3\omega \frac{\mu_0}{2\pi} \ln \frac{\delta}{d_{LN}}; \quad \underline{Z}'_{-L123S} = \underline{Z}'_{-LS} = 3\omega \frac{\mu_0}{8} + j3\omega \frac{\mu_0}{2\pi} \ln \frac{\delta}{r_{Sm}};$$

$$Z'_{NS} = \omega \frac{\mu_0}{8} + j\omega \frac{\mu_0}{2\pi} \ln \frac{\delta}{r_{Sm}} ;$$

Reduction factor:

$$r = 1 - \frac{1}{3} \cdot \frac{Z'_N Z'_{LS} + Z'_S Z'_{LN} - Z'_{NS} (Z'_{LN} + Z'_{LS})}{Z'_N Z'_S - Z'^2_{NS}} \tag{29}$$

Table 14 gives the results found with Equations (26) to (29) for cables NYCWY with four equal conductors. The data $r_L, R'_L, r_N = r_L, R'_N = R'_L$ and $d = d_{LN}$ are the same as in Table 12a.

Table 14 – Low-voltage cable NYCWY with four copper conductors

q_n a)	D_a	r_{Sm} b)	R'_S c)	$Z'_{(1)NS}$ (see Table 12a)	$\frac{R'_{(0)NS}}{R'_{(1)NS}}$	$\frac{X'_{(0)NS}}{X'_{(1)NS}}$	$\frac{R'_{(0)NSE}}{R'_{(1)NS}}$	$\frac{X'_{(0)NSE}}{X'_{(1)NS}}$	r
mm ²	mm	mm	Ω/km	Ω/km	-	-	-	-	-
4 × 25/16rST	30	13,2	1,12	0,727+j0,0878	2,82	2,19	2,23	7,90	0,50
4 × 35/16 sST	29	12,7	1,12	0,524+j0,0850	3,05	2,41	2,48	6,51	0,42
4 × 50/25 sST	34	15,0	0,714	0,387+j0,0846	2,96	2,28	2,57	4,60	0,32
4 × 70/35 sST	38	16,9	0,510	0,268+j0,0824	3,01	2,30	2,69	3,54	0,24
4 × 95/50 sST	43	19,2	0,357	0,193+j0,0820	3,02	2,25	2,76	2,92	0,18
4 × 120/70 sST	47	21,1	0,255	0,153+j0,0805	2,99	2,15	2,77	2,56	0,15
4 × 150/70 sST	51	22,9	0,255	0,124+j0,0802	3,19	2,31	2,94	2,61	0,14
4 × 185/95 sST	57	25,7	0,188	0,0991+j0,0803	3,22	2,21	2,99	2,40	0,11
4 × 240/120 sST	64	29,0	0,149	0,0754+j0,0799	3,42	2,19	3,18	2,30	0,10

NOTE The data $r_L, R'_L, r_N = r_L, R'_N = R'_L$ and d are given in Table 12a.
 a) See Table 6.
 b) $r_{Sm} = 0,5(r_{Sa} + r_{Si})$.
 c) $\kappa_S = 56 \text{ Sm/mm}^2$.

Cable with three conductors N(A)YCWY:

$$Z'_{(1)S} = R'_L + j\omega \frac{\mu_0}{2\pi} \left(\frac{1}{4} + \ln \frac{d}{r_L} \right) \quad \text{[(see Equation (18))]} \tag{30}$$

Current return through the concentric copper conductor (shield S):

$$Z'_{(0)S} = R'_L + 3R'_S + j\omega \frac{\mu_0}{2\pi} \left(\frac{1}{4} + 3 \ln \frac{r_{Sm}}{\sqrt[3]{r_L d^2}} \right) \tag{31}$$

with the medium radius of the shield or sheath $r_{Sm} = 0,5(r_{Sa} + r_{Si})$.

Current return through the concentric copper conductor (shield S) and the earth E:

$$\underline{Z}'_{(0)SE} = R'_L + 3\omega \frac{\mu_0}{8} + j\omega \frac{\mu_0}{2\pi} \left(\frac{1}{4} + 3 \ln \frac{\delta}{\sqrt[3]{r_L d^2}} \right) - 3 \frac{\left(\omega \frac{\mu_0}{8} + j\omega \frac{\mu_0}{2\pi} \ln \frac{\delta}{r_{Sm}} \right)^2}{R'_S + \omega \frac{\mu_0}{8} + j\omega \frac{\mu_0}{2\pi} \ln \frac{\delta}{r_{Sm}}} \quad (32)$$

Reduction factor:
$$r = \frac{R'_S}{R'_S + \omega \frac{\mu_0}{8} + j\omega \frac{\mu_0}{2\pi} \ln \frac{\delta}{r_{Sm}}} \quad (33)$$

Table 15 – Low-voltage cable NYCWY

a) with three copper conductors

q_n	r_L a)	R'_L b)	r_{Sm} c)	R'_S d)	d e)	$\underline{Z}'_{(1)S}$ Equation (30)	$\frac{R'_{(0)S}}{R'_{(1)S}}$	$\frac{X'_{(0)S}}{X'_{(1)S}}$	$\frac{R'_{(0)SE}}{R'_{(1)S}}$	$\frac{X'_{(0)SE}}{X'_{(1)S}}$	r
mm ²	mm	Ω/km	mm	Ω/km	mm	Ω/km	-	-	-	-	-
3 × 25rST/16	3,24	0,727	11,6	1,12	9,11	0,727+j 0,0807	5,62	1,56	2,39	19,26	0,82
3 × 35sST/16	3,82	0,524	11,1	1,12	10,3	0,524+j 0,0780	7,41	1,18	2,93	19,50	0,82
3 × 50sST/25	4,54	0,387	12,9	0,714	12,2	0,387+j 0,0778	6,53	1,14	3,73	13,96	0,69
3 × 70sST/35	5,40	0,268	15,0	0,510	13,8	0,268+j 0,0747	6,71	1,21	4,66	10,34	0,57
3 × 95sST/50	6,30	0,193	17,3	0,357	16,1	0,193+j 0,0747	6,55	1,18	5,28	6,71	0,45
3 × 120sST/70	7,10	0,153	18,2	0,255	17,7	0,153+j 0,0731	6,00	1,07	5,30	4,34	0,34
3 × 150sST/70	7,95	0,124	20,6	0,255	19,9	0,124+j 0,0734	7,17	1,10	6,29	4,37	0,35
3 × 185sST/95	8,80	0,0991	22,9	0,188	22,0	0,0991+j 0,0733	6,69	1,10	6,18	3,03	0,27
3 × 240sST/120	10,05	0,0754	25,7	0,149	24,8	0,0754+j 0,0725	6,93	1,09	6,56	2,37	0,22
3 × 300sST/150	11,25	0,0601	28,5	0,119	27,8	0,0601+j 0,0725	6,94	1,06	6,68	1,91	0,18

a) See Table 12a.
 b) See Table 12a.
 c) $r_{Sm} = 0,5(r_{Sa} + r_{Si})$
 d) $\kappa_S = 56 \text{ Sm/mm}^2$.
 e) $d = \sqrt[3]{d_{L1L2} d_{L1L3} d_{L2L3}}$.

b) with three aluminium conductors

q_n	r_L a)	R'_L b)	r_{Sm} c)	R'_S d)	d 5)	$Z'_{(1)S}$ Equation (30)	$\frac{R'_{(0)S}}{R'_{(1)S}}$	$\frac{X'_{(0)S}}{X'_{(1)S}}$	$\frac{R'_{(0)SE}}{R'_{(1)S}}$	$\frac{X'_{(0)SE}}{X'_{(1)S}}$	r
mm ²	mm	Ω/km	mm	Ω/km	mm	Ω/km	-	-	-	-	-
3×50s/50	4,00	0,641	12,3	0,357	10,7	0,641+j 0,0775	2,67	1,34	2,31	6,59	0,44
3×70s/70	4,72	0,443	13,7	0,255	12,1	0,443+j 0,0749	2,73	1,31	2,50	4,45	0,33
3×95s/95	5,50	0,320	15,8	0,188	14,1	0,320+j 0,0749	2,76	1,29	2,62	3,12	0,26
3×120s/120	6,18	0,253	17,2	0,149	15,4	0,253+j 0,0731	2,77	1,29	2,66	2,51	0,21
3×150s/150	6,91	0,206	19,0	0,119	17,3	0,206+j 0,0734	2,73	1,24	2,66	2,05	0,17
3×185s/185	7,67	0,164	20,0	0,0965	19,2	0,164+j 0,0734	2,77	1,11	2,71	1,62	0,14

- a) See Table 12b.
- b) See Table 12b.
- c) $r_{Sm} = 0,5(r_{Sa} + r_{Si})$.
- d) $\kappa_S = 56 \text{ Sm/mm}^2$.
- e) $d = \sqrt[3]{d_{L1}d_{L2}d_{L1}d_{L3}d_{L2}d_{L3}}$.

Type C:

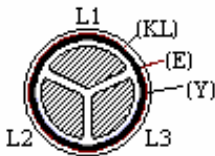

Belted cable with three copper or aluminium (A) conductors, a mass-impregnated paper insulation for conductors (and belt), a smooth extruded aluminium sheath (KL), protective covering with an embedded layer of elastomer tape or plastic film (E) and a sheath of thermoplastic material based on PVC (Y): N(A)KLEY

Equations (30) to (33) are valid for the positive-sequence, the zero-sequence impedance and the reduction factor as for cables of type B with three conductors. Cables N(A)KLEY are used in former times for local networks. The aluminium sheath then was applied as a neutral conductor N or PEN [3].

Type D:

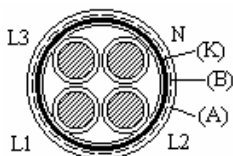

Cable with four (or three and a half) copper or aluminium (A) conductors, a mass-impregnated paper insulation for conductors (and belt), lead sheath (K) with steel tape armouring (B) and an outer serving of fibrous material (A): N(A)KBA

These cables are used in former times in low-voltage distribution networks, if the additional earthing by the lead-sheath was necessary [3].

Calculation of the positive-sequence, the zero-sequence impedance and the reduction factor is possible, when neglecting the steel tape armouring, with Equations (26) to (29) in case of four (or three and a half) conductors respectively Equations (30) to (33) in case of four conductors.

The reduction factor in case of a lead sheath and the armouring with at least two overlapping steel tapes is found by measurement [3]. The results published in [3] are given in the Figures 11 and 12 for information.

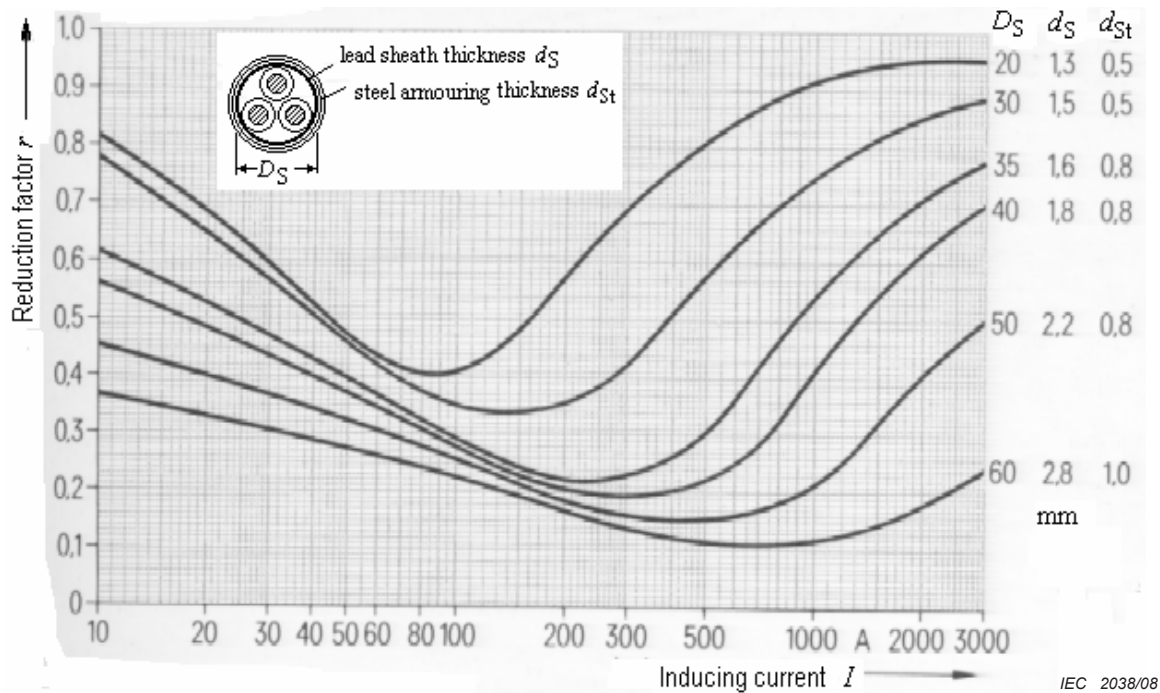

Figure 11 – Reduction factor depending on the inducing current for cables with one lead sheath and two overlapping steel tapes, $f = 50$ Hz [3]

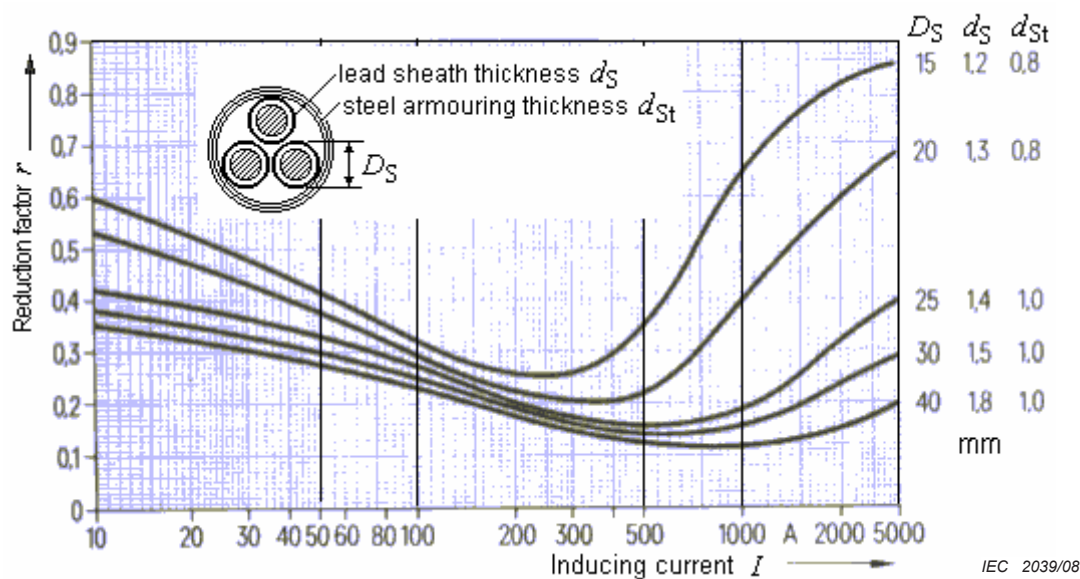

Figure 12 – Reduction factor depending on the inducing current for cables with three lead sheaths and two overlapping steel tapes, $f = 50$ Hz [3]

2.6 Data of typical asynchronous motors

The ratio locked-rotor current to rated current I_{LR}/I_{rM} is different for low- and medium-voltage motors. For low-voltage motors the average value is approximately 6,7 in the range 2 kW to 300 kW per pair of poles. The average value for medium-voltage motors is approximately 5,5 in the range 30 kW to 6 MW per pair of poles.

In Table 16 actual data of asynchronous motors are given.

Table 16 – Actual data of typical asynchronous motors

No.	Rated power	Rated voltage	Rated current	Power factor	Efficiency (rated)	Ratio	Rotation speed	Number of pair of poles	DC Time constant	Country
	P_{rM}	U_{rM}	I_{rM}	$\cos \varphi_{rM}$	η_{rM}	$\frac{I_{LR}}{I_{rM}}$	n_r	p	T_{DC}	
	kW	kV	A	–	–	–	1/min	–	s	
1	45	0,38	80	0,89	0,92	7,14	2950	1	–	Bulgaria
2	200	0,38	370	$\cos \varphi_{rM} \times \eta_{rM} = 0,82$		6,4	–	2	0,013	ex-Czechoslovakia
3	250	6,0	29	0,89	0,94	5,3	2973	1	0,05	Germany
4	500	6,0	62	0,83	0,94283	5,8	741	4	0,053	GRD
5	1 000	6,0	121	0,85	0,985	5,0	590	5	0,031	ex-USSR
6	3 150	6,0	380	$\cos \varphi_{rM} \times \eta_{rM} = 0,80$		5,2	-	6	0,064	ex-Czechoslovakia
7	6 000	6,0	660	0,90	0,972	5,5	1490	2	-	Italy
8	315	6,0	36,5	0,88	0,942	6,2	1794	2	-	Norway, 60 Hz
9	6 000	6,6	595	0,91	0,969	4,5	1776	2	0,055	Japan, 60 Hz
10	9 698	6,6	963	0,917	0,961	6,23	1190	3	0,0968	USA, 60 Hz

In Figure 13 the ratio I_{LR}/I_{rM} and in Figure 14 the product $\cos \varphi_{rM} \times \eta_{rM}$ of power factor and efficiency is plotted as a function of the active power per pair of poles P_{rM}/p .

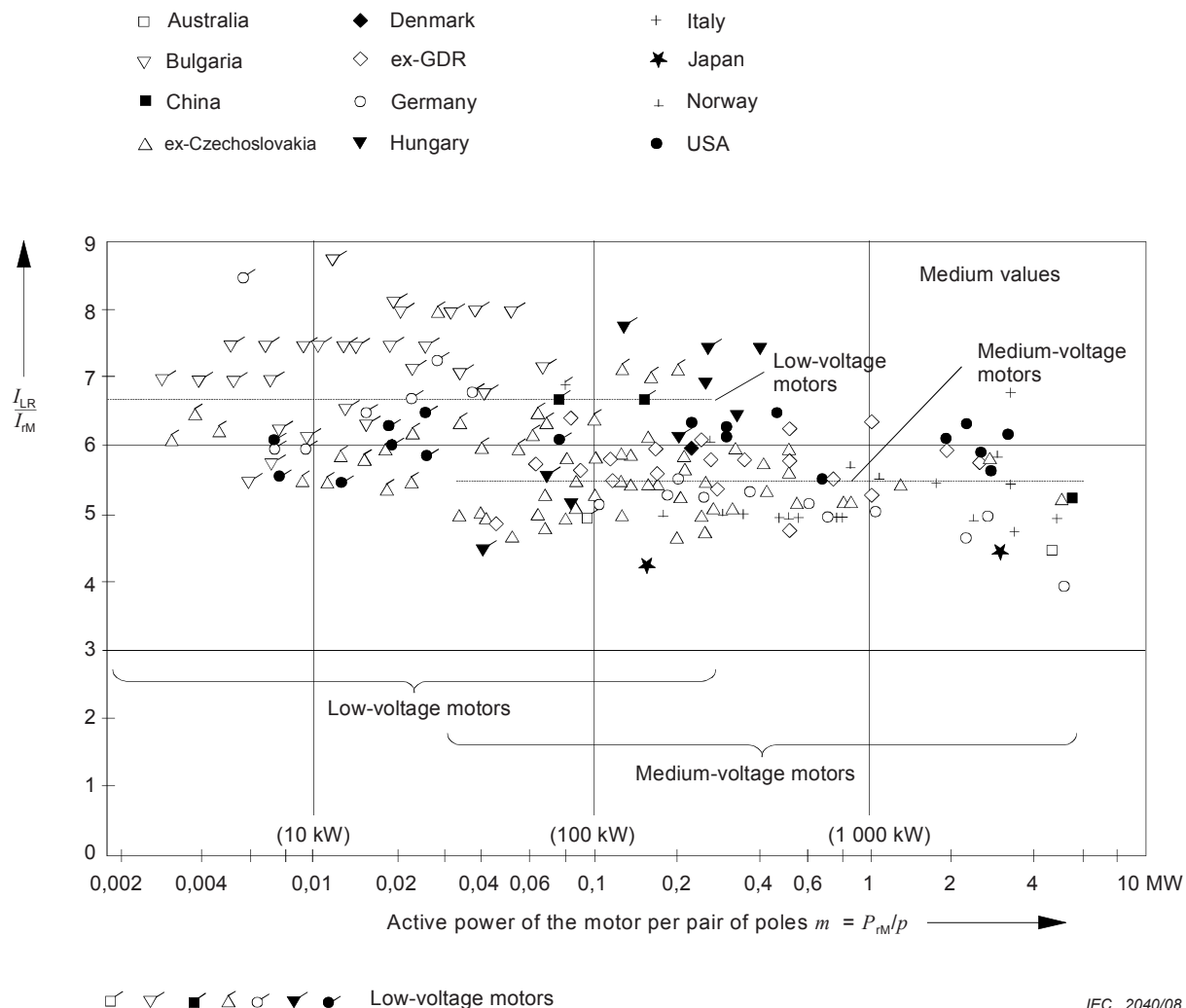

Figure 13 – Ratio I_{LR}/I_{rM} of low-voltage and medium-voltage asynchronous motors, 50 Hz and 60 Hz

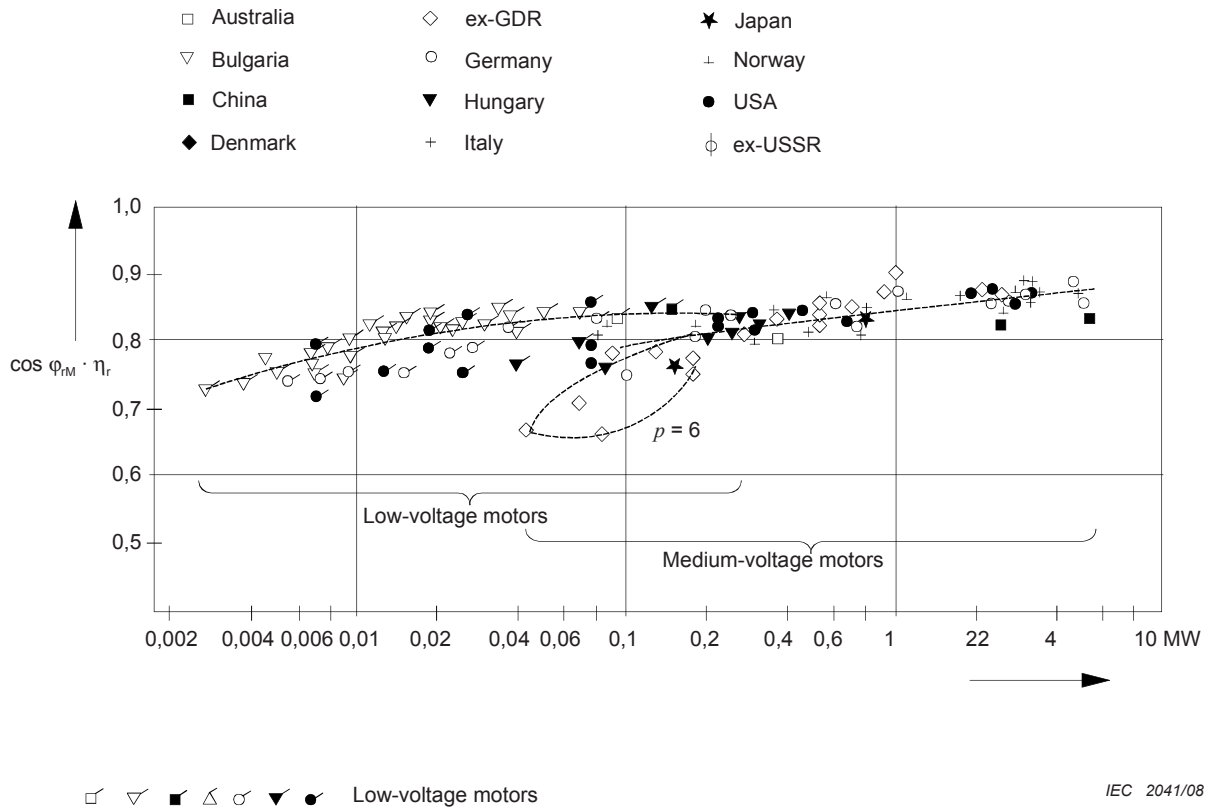

Figure 14 – Product $\cos \varphi_{TM} \times \eta_{rM}$ of low-voltage and medium-voltage motors, 50 Hz and 60 Hz

2.7 Busbars

Collected data of busbars are given in Table 17.

Table 17 – Actual data of distribution busbars

No.	Rated voltage U_r	Rated current I_r	Conductors			Sheath material	Current return b)	Positive-sequence impedance $Z'_{(1)} = R'_{(1)} + jX'_{(1)}$	Zero-sequence impedance $Z'_{(0)} = R'_{(0)} + jX'_{(0)}$	Country
			Number	Material	Cross section					
	kV	A	-	-	mm ²	-		Ω/km	Ω/km	
1	0,38/ 0,66	1 250	3	Al	1 120	Al	S+E	0,0380+j0,0163	0,0882+j0,0689	ex-USSR
2	(0,40/ 0,69)	1 600	3	Al	1 280	Al	S+E	0,0297+j0,0143	0,0672+j0,0555	ex-USSR
3		3 200 a)	3×2	Al	2 650	Al	S+E	0,0101+j0,00495	0,0735+j0,0392	ex-USSR

a) Split bar 2 × 1 600 A.

b) Current return through sheath (S) and earth (E).

A calculation of the medium positive-sequence reactance per unit length of busbars (without sheath or shielding) with one, two or three parallel bars (Cu or Al) per main conductor L1, L2 or L3 is possible with the following equation, using the theory of geometric mean distance [5]:

$$X'_{(1)} = \omega \frac{\mu_0}{2\pi} \ln \frac{\sqrt[3]{g_{L1L2}^2 g_{L1L3}}}{g_{L1L1}} = \omega \frac{\mu_0}{2\pi} \ln \frac{\sqrt[3]{(\alpha d_{L1L2})^2 (\beta d_{L1L3})}}{g_{L1L1}} \quad (34)$$

Approximations for the geometric mean distance g_{L1L1} are given in Figure 15.

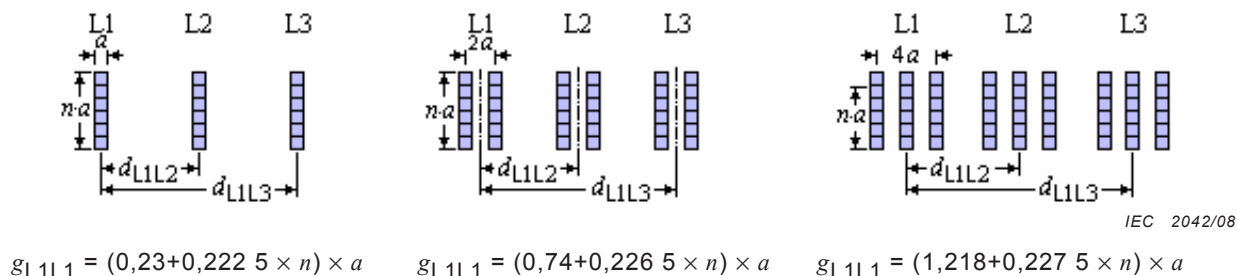
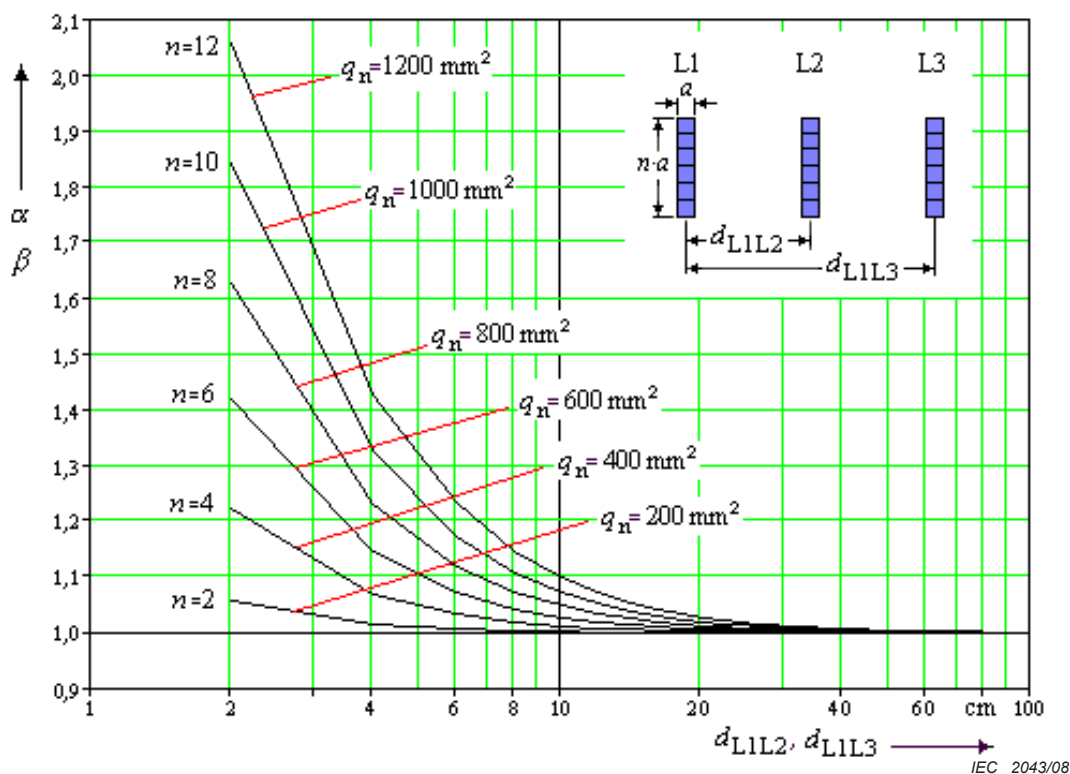
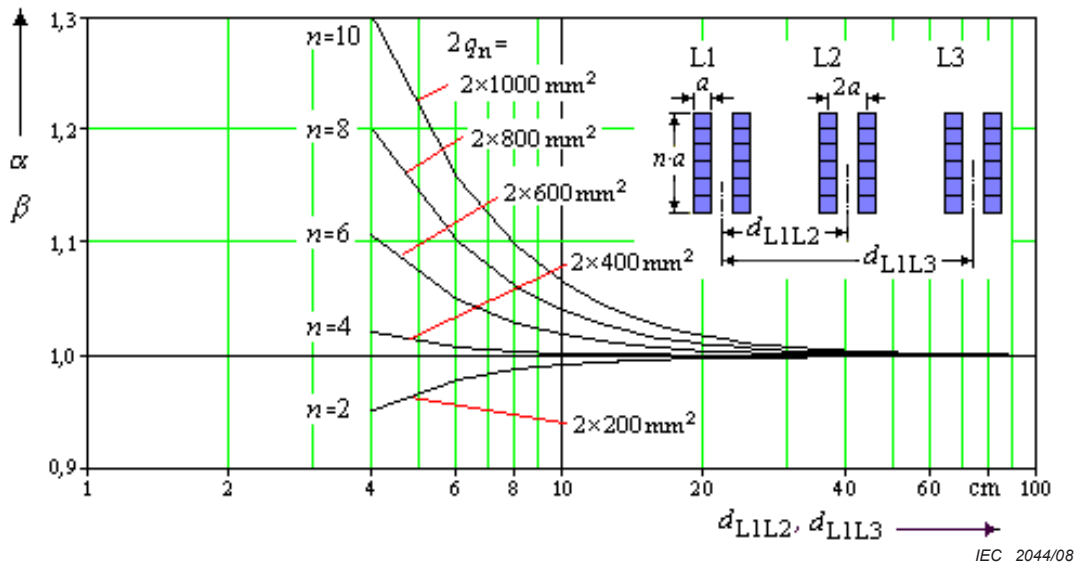

Figure 15 – Geometric mean distance $g_{L1L1} = g_{L2L2} = g_{L3L3}$ of the main conductors

The factors $\alpha = g_{L1L2} / d_{L1L2}$ and $\beta = g_{L1L3} / d_{L1L3}$ are given in the Figures 16a, 16b, 16c for one, two or three bars per main conductor (Figure 15), depending on the distance d_{L1L2} ($d_{L1L3} = 2 \cdot d_{L1L2}$) and the factor $n = 2, 4, 6, \dots$ (see Figure 15).



a) For one bar per main conductor; $a = 10$ mm



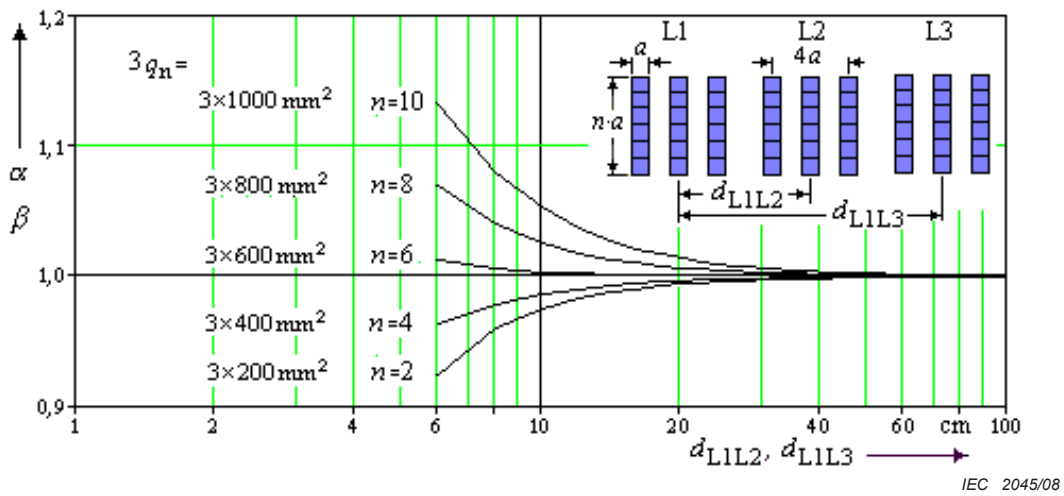

b) For two bars per main conductor; $a = 10 \text{ mm}$



c) For three bars per main conductor; $a = 10 \text{ mm}$

Figure 16 – Factor α and β for the calculation of $X'_{(1)}$ given in Equation (34)

Table 18 – Example for the calculation of $X'_{(1)}$ for busbars using Figures 15 and 16

Three-phase a.c. busbar, Cu, 50 Hz, L1, L2, L3				
$a \times n \times a$ (Fig 15)	mm	60×10	2×60×10	3×60×10
q_n	mm ²	600	1 200	1 800
g_{L1L1} (Figure 15)	cm	1,565	2,099	2,583
$g_{L1L2} = \alpha \times d_{L1L2}$ (Figure 16)	cm	1,071 × 6 = 6,426	1,050 × 6 = 6,300	1,013 × 6 = 6,078
$g_{L1L3} = \beta \times d_{L1L3}$ (Figure 16)	cm	1,022 × 12 = 12,264	1,013 × 12 = 12,156	1,002 × 12 = 12,024
$X'_{(1)}$ (Equation 34)	Ω/km	0,102	0,083	0,068

Annex A (informative)

Information from National Committees

Data given in the Tables 1, 2, 3, 4, 5, 6, 16 and 17 of this publication are collected from different countries. In all, 15 National Committees provided information for the first edition of IEC/TR 60909-2: 1992. Information received at that time is listed in the following Table A.1 (see Table 1 of IEC/TR 60909-2: 1992).

Table A.1 – Information received from National Committees

National Committee	Number of answers to questionnaire tables						
	1	2	3	4	5	6	7
Australia	3	3	3	3	3	3	3
Austria	10	11	4	1	8	7	-
Bulgaria	4	15	6	6	14	11	28
China	3	3	3	3	3	3	3
ex-Czechoslovakia	8	5	-	3	9	5	68
Denmark	8	18	1	2	8	15	-
ex-GDR	23	28	9	6	8	-	20
Germany	21	26	2	2	5	13	19
Hungary	7	16	3	5	9	8	9
Italy	25	16	4	6	26	9	11
Japan	12	10	7	7	7	9	3
Norway	9	10	4	3	9	8	10
UK	-	11	1	5	-	-	-
USA	110	10	1	-	-	10	20
ex-USSR	12	6	3	5	4	-	10
Total	255	188	51	57	113	101	204

Bibliography

- [1] Balzer, G., *Impedanzmessungen in Niederspannungsnetzen zur Bestimmung der Kurzschlußströme* (Measurement of impedances in low-voltage networks for the determination of short-circuit currents) Diss. TH Darmstadt 1977.
 - [2] Meyer, E. P., *Stromrückleitung über das Erdreich, Impedanzen und induktive Beeinflussung bei Leitern endlicher Länge* (Current return through the earth, impedances and inductive interference in the case of conductors with limited length) Diss. TH Darmstadt 1982.
 - [3] Heinhold, L., *Kabel und Leitungen für Starkstrom*, Part 1:1987, Part 2:1989. Siemens Aktiengesellschaft.
 - [4] NEXANS, *Energy Networks Germany. Insulated Cables for High and Extra High Voltage*. Nexans Deutschland Industries AG & Co. KG, 2000.
 - [5] Oeding, D., Oswald, B. R., *Elektrische Kraftwerke und Netze*, 6. Edition: Springer 2004.
 - [6] IEC 60038: 2002, *IEC standard voltages*
 - [7] IEC/TR 60909-1:2002, *Short-circuit currents in three-phase a.c. systems – Part 1: Factors for the calculation of short-circuit currents according to IEC 60909-0*
 - [8] IEC/TR 60909-4:2000, *Short-circuit currents in three-phase a.c. systems – Part 4: Examples for the calculation of short-circuit currents*
-

British Standards Institution (BSI)

BSI is the national body responsible for preparing British Standards and other standards-related publications, information and services.

BSI is incorporated by Royal Charter. British Standards and other standardization products are published by BSI Standards Limited.

About us

We bring together business, industry, government, consumers, innovators and others to shape their combined experience and expertise into standards-based solutions.

The knowledge embodied in our standards has been carefully assembled in a dependable format and refined through our open consultation process. Organizations of all sizes and across all sectors choose standards to help them achieve their goals.

Information on standards

We can provide you with the knowledge that your organization needs to succeed. Find out more about British Standards by visiting our website at bsigroup.com/standards or contacting our Customer Services team or Knowledge Centre.

Buying standards

You can buy and download PDF versions of BSI publications, including British and adopted European and international standards, through our website at bsigroup.com/shop, where hard copies can also be purchased.

If you need international and foreign standards from other Standards Development Organizations, hard copies can be ordered from our Customer Services team.

Subscriptions

Our range of subscription services are designed to make using standards easier for you. For further information on our subscription products go to bsigroup.com/subscriptions.

With **British Standards Online (BSOL)** you'll have instant access to over 55,000 British and adopted European and international standards from your desktop. It's available 24/7 and is refreshed daily so you'll always be up to date.

You can keep in touch with standards developments and receive substantial discounts on the purchase price of standards, both in single copy and subscription format, by becoming a **BSI Subscribing Member**.

PLUS is an updating service exclusive to BSI Subscribing Members. You will automatically receive the latest hard copy of your standards when they're revised or replaced.

To find out more about becoming a BSI Subscribing Member and the benefits of membership, please visit bsigroup.com/shop.

With a **Multi-User Network Licence (MUNL)** you are able to host standards publications on your intranet. Licences can cover as few or as many users as you wish. With updates supplied as soon as they're available, you can be sure your documentation is current. For further information, email bsmusales@bsigroup.com.

BSI Group Headquarters

389 Chiswick High Road London W4 4AL UK

Revisions

Our British Standards and other publications are updated by amendment or revision.

We continually improve the quality of our products and services to benefit your business. If you find an inaccuracy or ambiguity within a British Standard or other BSI publication please inform the Knowledge Centre.

Copyright

All the data, software and documentation set out in all British Standards and other BSI publications are the property of and copyrighted by BSI, or some person or entity that owns copyright in the information used (such as the international standardization bodies) and has formally licensed such information to BSI for commercial publication and use. Except as permitted under the Copyright, Designs and Patents Act 1988 no extract may be reproduced, stored in a retrieval system or transmitted in any form or by any means – electronic, photocopying, recording or otherwise – without prior written permission from BSI. Details and advice can be obtained from the Copyright & Licensing Department.

Useful Contacts:

Customer Services

Tel: +44 845 086 9001

Email (orders): orders@bsigroup.com

Email (enquiries): cservices@bsigroup.com

Subscriptions

Tel: +44 845 086 9001

Email: subscriptions@bsigroup.com

Knowledge Centre

Tel: +44 20 8996 7004

Email: knowledgecentre@bsigroup.com

Copyright & Licensing

Tel: +44 20 8996 7070

Email: copyright@bsigroup.com