

PD ISO/IEC PAS 60127-8:2014



BSI Standards Publication

Miniature fuses

Part 8: Fuse resistors with particular overcurrent protection

bsi.

...making excellence a habit.™

National foreword

This Published Document is the UK implementation of ISO/IEC PAS 60127-8:2014.

The UK participation in its preparation was entrusted to Technical Committee PEL/32, Fuses.

A list of organizations represented on this committee can be obtained on request to its secretary.

This publication does not purport to include all the necessary provisions of a contract. Users are responsible for its correct application.

© The British Standards Institution 2015
Published by BSI Standards Limited 2015.

ISBN 978 0 580 87887 9

ICS 29.120.50

Compliance with a British Standard cannot confer immunity from legal obligations.

This Published Document was published under the authority of the Standards Policy and Strategy Committee on 31 January 2015.

Amendments/corrigenda issued since publication

Date	Text affected
-------------	----------------------



IEC PAS 60127-8

Edition 1.0 2014-12

PUBLICLY AVAILABLE SPECIFICATION

PRE-STANDARD

**Miniature fuses –
Part 8: Fuse resistors with particular overcurrent protection**

INTERNATIONAL
ELECTROTECHNICAL
COMMISSION

PRICE CODE

T

ICS 29.120.50

ISBN 978-2-8322-1982-9

Warning! Make sure that you obtained this publication from an authorized distributor.

CONTENTS

FOREWORD.....	4
INTRODUCTION.....	6
1 Scope.....	7
2 Normative references	7
3 Terms and definitions	8
4 General requirements	10
5 Standard ratings	10
6 Marking	10
7 General notes on tests	11
7.1 Atmospheric conditions for testing	11
7.2 Type tests.....	11
7.3 Fuse-bases for tests	12
7.3.1 General requirements	12
7.3.2 Through-hole mounting of fuse resistors with particular overcurrent protection	12
7.3.3 Surface mounting of fuse resistors with particular overcurrent protection	12
7.4 Nature of supply	12
8 Dimensions and construction	12
8.1 Dimensions	12
8.1.1 Creepage distances and clearances	13
8.2 Construction	13
8.3 Terminations.....	14
8.3.1 Through-hole mount fuse resistors with particular overcurrent protection	14
8.3.2 Surface mount fuse resistors with particular overcurrent protection	14
8.4 Alignment and configuration of terminations.....	14
8.5 Soldered joints.....	15
8.6 Solderability of terminations.....	15
8.7 Resistance to soldering heat.....	15
9 Electrical requirements	15
9.1 Resistance value	15
9.2 Functioning characteristic at the minimum breaking dissipation.....	15
9.2.1 Functioning characteristic at an ambient temperature of 70 °C	15
9.2.2 Test at elevated temperature	16
9.2.3 Test procedure	16
9.2.4 Presentation of results.....	16
9.3 Rated breaking capacity.....	16
9.3.2 Criteria for satisfactory performance	17
9.3.3 Insulation resistance.....	17
9.4 Endurance tests	17
9.5 Maximum sustained dissipation.....	18
9.6 Pulse tests.....	18
9.7 Temperature of fuse resistors with particular overcurrent protection.....	18
9.8 Operating overvoltage.....	18
Bibliography.....	25

Figure 1 – Test board for through-hole mount fuse resistors with particular overcurrent protection 20

Figure 2 – Test board for surface mount fuse resistors with particular overcurrent protection 21

Figure 3 – Test fuse-base 22

Figure 4 – Bending jig for surface mount fuse resistors with particular overcurrent protection 23

Figure 5 – Test circuit for the tests according to 9.3..... 24

Table 1 – Creepage distances and clearances (absolute minimum values) 13

Table 2 – Test voltages for dielectric strength..... 17

Table 3 – Testing schedule for individual dissipation ratings 19

INTERNATIONAL ELECTROTECHNICAL COMMISSION

MINIATURE FUSES –

Part 8: Fuse resistors with particular overcurrent protection

FOREWORD

- 1) The International Electrotechnical Commission (IEC) is a worldwide organization for standardization comprising all national electrotechnical committees (IEC National Committees). The object of IEC is to promote international co-operation on all questions concerning standardization in the electrical and electronic fields. To this end and in addition to other activities, IEC publishes International Standards, Technical Specifications, Technical Reports, Publicly Available Specifications (PAS) and Guides (hereafter referred to as "IEC Publication(s)"). Their preparation is entrusted to technical committees; any IEC National Committee interested in the subject dealt with may participate in this preparatory work. International, governmental and non-governmental organizations liaising with the IEC also participate in this preparation. IEC collaborates closely with the International Organization for Standardization (ISO) in accordance with conditions determined by agreement between the two organizations.
- 2) The formal decisions or agreements of IEC on technical matters express, as nearly as possible, an international consensus of opinion on the relevant subjects since each technical committee has representation from all interested IEC National Committees.
- 3) IEC Publications have the form of recommendations for international use and are accepted by IEC National Committees in that sense. While all reasonable efforts are made to ensure that the technical content of IEC Publications is accurate, IEC cannot be held responsible for the way in which they are used or for any misinterpretation by any end user.
- 4) In order to promote international uniformity, IEC National Committees undertake to apply IEC Publications transparently to the maximum extent possible in their national and regional publications. Any divergence between any IEC Publication and the corresponding national or regional publication shall be clearly indicated in the latter.
- 5) IEC itself does not provide any attestation of conformity. Independent certification bodies provide conformity assessment services and, in some areas, access to IEC marks of conformity. IEC is not responsible for any services carried out by independent certification bodies.
- 6) All users should ensure that they have the latest edition of this publication.
- 7) No liability shall attach to IEC or its directors, employees, servants or agents including individual experts and members of its technical committees and IEC National Committees for any personal injury, property damage or other damage of any nature whatsoever, whether direct or indirect, or for costs (including legal fees) and expenses arising out of the publication, use of, or reliance upon, this IEC Publication or any other IEC Publications.
- 8) Attention is drawn to the Normative references cited in this publication. Use of the referenced publications is indispensable for the correct application of this publication.
- 9) Attention is drawn to the possibility that some of the elements of this IEC Publication may be the subject of patent rights. IEC shall not be held responsible for identifying any or all such patent rights.

A PAS is a technical specification not fulfilling the requirements for a standard, but made available to the public.

IEC PAS 60127-8 has been processed by subcommittee 32C: Miniature fuses, of IEC technical committee 32: Fuses.

The text of this PAS is based on the following document:

This PAS was approved for publication by the P-members of the committee concerned as indicated in the following document

Draft PAS	Report on voting
32C/500/PAS	32C/503/RVD

Following publication of this PAS, which is a pre-standard publication, the technical committee or subcommittee concerned may transform it into an International Standard.

A list of all parts in the IEC 60127, published under the general title *Miniature fuses*, can be found on the IEC website.

This PAS shall remain valid for an initial maximum period of 3 years starting from the publication date. The validity may be extended for a single period up to a maximum of 3 years, at the end of which it shall be published as another type of normative document, or shall be withdrawn.

INTRODUCTION

In recent years, so-called “fuse resistors” have increasingly been used in electrical and electronic applications. The term “fuse resistor”, however, which has become established in the market, is misleading. The actual function of a fuse resistor is that of a resistor in an electrical or electronic circuit. Only when an overload of multiple times the rated dissipation occurs can fuse resistors interrupt an electric current. In a wide range between the rated dissipation and the manufacturer’s specified breaking dissipation, fuse resistors provide poor or no overcurrent protection. So if they are incorrectly rated and improperly used in an application, this may result in potential risk of fire.

Fuse resistors perform the function of a fuse only within a particular overcurrent range, and, from a technical point of view, must therefore be referred to as “fuse resistors with particular overcurrent protection”.

Fuse resistors with particular overcurrent protection can safely interrupt high short-circuit currents, but are not capable of interrupting overload currents.

For safety reasons, they shall therefore only be used in combination with an accompanying overload current protection device, i.e. a true fuse, if overload currents cannot be excluded to occur in the respective application.

MINIATURE FUSES –

Part 8: Fuse resistors with particular overcurrent protection

1 Scope

This part of IEC 60127 relates to fuse resistors with particular overcurrent protection rated up to 500 V a.c. and/or 500 V d.c. for printed circuits and other substrate systems, used for the protection of electric appliances, electronic equipment and component parts thereof, normally intended to be used indoors.

It does not apply to fuse resistors with particular overcurrent protection for appliances intended to be used under special conditions, such as in a corrosive or explosive atmosphere.

The object of this PAS is

- a) to establish uniform requirements for fuse resistors with particular overcurrent protection so as to protect appliances or parts of appliances in the most suitable way;
- b) to define the performance of the fuse resistors with particular overcurrent protection, so as to give guidance to manufacturers of electrical appliances and electronic equipment and to ensure replacement of fuse resistors with particular overcurrent protection by those of similar dimensions and characteristics;
- c) to define methods of testing.

This PAS applies in addition to the requirements of IEC 60127-1.

NOTE Manufacturers of fuse resistors with particular overcurrent protection must ensure on their own responsibility that their products comply with the requirements of the resistor-related standards IEC 60115-1, IEC 60115-4-101 and IEC 60115-4-102 (withdrawn).

The object of this PAS is to establish uniform test methods for fuse resistors with particular overcurrent protection, so as to allow verification of the values (for example rated dissipation, functioning characteristic and rated breaking capacity values) specified by the manufacturer.

2 Normative references

The following documents, in whole or in part, are normatively referenced in this document and are indispensable for its application. For dated references, only the edition cited applies. For undated references, the latest edition of the referenced document (including any amendments) applies.

IEC 60063:1963, *Preferred number series for resistors and capacitors*
Amendment 1:1967
Amendment 2:1977

IEC 60068-2-21:2006, *Environmental testing – Part 2-21: Tests – Test U: Robustness of terminations and integral mounting devices*

IEC 60127-1:2006, *Miniature fuses – Part 1: Definitions for miniature fuses and general requirements for miniature fuse-links*

IEC 60194:2006, *Printed board design, manufacture and assembly – Terms and definitions*

IEC 60695-2-12:2010, *Fire hazard testing – Part 2-12: Glowing/hot-wire based test methods – Glow-wire flammability index (GWFI) test method for materials*

IEC 60695-2-13:2010, *Fire hazard testing – Part 2-13: Glowing/hot-wire based test methods – Glow-wire ignition temperature (GWIT) test method for materials*

IEC 60695-4:2012, *Fire hazard testing – Part 4: Terminology concerning fire tests for electrotechnical products*

IEC 61249-2-7:2002, *Materials for printed boards and other interconnecting structures – Part 2-7: Reinforced base materials clad and unclad – Epoxide woven E-glass laminated sheet of defined flammability (vertical burning test), copper-clad*

3 Terms and definitions

For the purposes of this document, the terms and definitions given in Clause 3 of IEC 60127-1:2006, as well as the following apply.

3.28

fuse resistor with particular overcurrent protection

fuse resistor capable of continuously carrying currents up to at least the rated power dissipation and of interrupting currents above a defined multiple of the rated dissipation up to its rated breaking capacity

Note 1 to entry: Fuse resistors with particular overcurrent protection can safely interrupt high short-circuit currents, but are not capable of interrupting overload currents. They are therefore allowed to be used only in combination with an accompanying overload current protection device such as a miniature fuse, if overload currents cannot be excluded to occur in the respective application.

3.29

fuse resistor with particular overcurrent protection for through-hole mounting

fuse resistor with particular overcurrent protection designed for soldering directly into a printed wiring board, with insertion of its leads in suitably designed holes

3.30

fuse resistor with particular overcurrent protection for surface mounting

fuse resistor with particular overcurrent protection designed for direct conductive attachment by solder or other means onto the surface of a substrate, without insertion of its leads in suitably designed holes or sockets

3.31

land

portion of a conductive pattern usually but not exclusively used for the connection and/or attachment of components (see IEC 60194)

Note 1 to entry: Further definitions which may be useful in the application of surface-mount fuse resistors with particular overcurrent protection may be found in IEC 60115-1 and IEC 60115-8.

3.32

critical resistance

resistance value at which the rated voltage is equal to the limiting element voltage

Note 1 to entry: At an ambient temperature of 70 °C, the maximum voltage which may be applied across the terminations of a fuse resistor with particular overcurrent protection is either the calculated rated voltage, if the resistance is less than the critical resistance, or the limiting element voltage, if the resistance is equal to or greater than the critical resistance. At temperatures other than 70 °C, it is important that account be taken of the derating curve and of the limiting element voltage in the calculation of any voltage to be applied.

Note 2 to entry: Related terminology: Rated voltage, limiting element voltage.

3.33**limiting element voltage** U_{\max}

maximum d.c. or a.c. r.m.s. voltage that may be continuously applied to the terminations of a fuse resistor with particular overcurrent protection (generally dependent upon size and manufacturing technology of the fuse resistor with particular overcurrent protection)

Note 1 to entry: Where the term "a.c. r.m.s. voltage" is used in this standard, the peak voltage should not exceed 1,42 times the r.m.s. value.

Note 2 to entry: This voltage can only be applied to fuse resistors with particular overcurrent protection when the resistance value is equal to or higher than the critical resistance value.

Note 3 to entry: Related terminology: rated voltage, critical resistance.

3.34**rated resistance**

resistance value for which the fuse resistor with particular overcurrent protection has been designed, and which is generally used for denomination of the fuse resistor with particular overcurrent protection

3.35**rated dissipation** P_{70}

maximum permissible dissipation at an ambient temperature of 70 °C under the conditions of the respective acceptance criteria

Note 1 to entry: If the rated dissipation depends on special means supporting the abduction of the dissipation to the environment, for example, special circuit board material, special conductor dimensions, heat-sink, such means have to be identified whenever the rated dissipation is mentioned.

Note 2 to entry: Related terminology: rated temperature, rated voltage.

3.36**rated temperature**

maximum ambient temperature at which the rated dissipation may be applied continuously

Note 1 to entry: The rated temperature has a value of 70 °C, unless otherwise prescribed in the relevant sectional specification.

Note 2 to entry: Related terminology: rated dissipation.

3.37**rated voltage of the fuse resistor with particular overcurrent protection** U_r

d.c. or a.c. r.m.s. voltage calculated from the square root of the product of the rated resistance and the rated dissipation

Note 1 to entry: At high values of resistance, the rated voltage may not be applicable because of the size and the construction of the fuse resistor with particular overcurrent protection.

Note 2 to entry: Related terminology: rated dissipation, limiting element voltage.

3.38**minimum breaking dissipation**

minimum value of the breaking dissipation which is equal to a multiple of the rated dissipation and at which the fuse resistor with particular overcurrent protection can still safely interrupt the circuit

Note 1 to entry: In this standard the minimum breaking dissipation is specified to be 16 times the rated dissipation. This value corresponds to the values given by most of the manufacturers.

4 General requirements

The requirements of IEC 60127-1:2006, Clause 4, are replaced as follows:

Fuse resistors with particular overcurrent protection shall be so constructed that their fuse function is reliable and safe and they are consistent in performance at the minimum breaking dissipation up to and including the breaking capacity rating and at any voltage up to the rated voltage, when used within the limits of this standard.

During normal use of the fuse resistor with particular overcurrent protection and within the conditions given in this standard, no permanent arc, nor external arcing, nor any flame that can endanger the surroundings, shall be produced. During testing and after operation, the fuse resistor with particular overcurrent protection shall not have suffered damage and the surroundings shall be unimpaired. Marking shall still be legible.

In general, compliance is checked by carrying out all the tests specified.

5 Standard ratings

The values of rated resistance shall be selected from the E12 or E24 series as given in IEC 60063.

6 Marking

The requirements of IEC 60127-1:2006, Clause 6, are replaced as follows:

6.1 Each fuse resistor with particular overcurrent protection shall be marked as follows:

- a) Rated resistance in ohm (abbreviation Ω or $m\Omega$).
- b) The marking of the tolerance on rated resistance shall follow and be adjacent to the marking of the rated resistance.
- c) Rated dissipation in watt (abbreviation W).
- d) Manufacturer's name or trade mark.
- e) The symbol "F" shall precede and be adjacent to the marking of the rated resistance.

6.2 Marking shall be indelible and easily legible.

In the case of screen or pad printing, compliance is checked by inspection and by rubbing the marking by hand for 15 s with a piece of cloth soaked in water and again for 15 s with a piece of cloth soaked in petroleum spirit.

NOTE 1 For petroleum spirit the use of an aliphatic solvent hexane, with an aromatics content of maximum 0,1 % volume, a kauri-butanol value of 29, initial boiling point approximately 65 °C, dry-point approximately 69 °C and specific gravity of approximately 0,68 is recommended.

NOTE 2 For all other printing techniques, the above test is not applicable.

6.3 The marking according to 6.1 shall also be printed on the packing together with a reference to this standard. The marking of the rated resistance on the packing shall include the abbreviation Ω or $m\Omega$. In addition, the marking of the rated dissipation P_{70} shall be printed on the packing.

Compliance is checked by inspection.

6.4 For colour coding, no test or requirement is specified.

6.5 Where marking is impracticable due to space limitations, the relevant information should appear on the smallest packing unit and in the manufacturer's technical literature.

7 General notes on tests

7.1 Atmospheric conditions for testing

See IEC 60127-1:2006, 7.1.

7.2 Type tests

The requirements of IEC 60127-1:2006, 7.2, are replaced as follows:

7.2.1 For fuse resistors with particular overcurrent protection designed and rated both for a.c. and d.c., the number of fuse resistors with particular overcurrent protection required is 36.

For fuse resistors with particular overcurrent protection designed only for a.c. or d.c., the number of fuse resistors with particular overcurrent protection required is 27.

18 fuse resistors with particular overcurrent protection are kept as spares.

The fuse resistors with particular overcurrent protection shall be tested or inspected in accordance with the following subclauses:

- a) Marking (see 6.1);
- b) Dimensions (see 8.1);
- c) Construction (see 8.2);
- d) Resistance (see 9.1);

with such additional tests as are specified in the following clauses of this standard.

7.2.2 Testing of the minimum and maximum rated resistance of the fuse resistors with particular overcurrent protection shall then be performed according to the testing schedule shown in Table 3.

In addition, any one rated resistance value per resistance decade shall be tested.

7.2.3

- a) No failure is allowed in any of the tests covered by 8.1.1, 9.1, 9.2 and 9.3.
- b) If in the test covered by Clause 6 and those tests described in 8.1 and 8.3, two failures occur at any one test breaking dissipation, the fuse resistors with particular overcurrent protection are deemed not to comply with this standard. If, however, one failure occurs, the test shall be repeated on twice the number of fuse resistors with particular overcurrent protection, at the same breaking dissipation and a second failure shall be a cause for rejection.

If two failures occur, but not both in the same test, the fuse resistors with particular overcurrent protection shall be deemed to comply provided that there are no further failures in repeat tests with twice the number of test samples.

If more than two failures occur, the fuse resistors with particular overcurrent protection shall be deemed not to comply with this standard.

7.3 Fuse-bases for tests

The requirements of IEC 60127-1:2006, 7.3, are replaced as follows:

7.3.1 General requirements

The fuse resistors with particular overcurrent protection shall be mounted upon the appropriate test board (see 7.3.2 or 7.3.3 as appropriate) by soldering.

This test board shall then be mounted on the test fuse-base (Figure 3). The test board shall be made of epoxide woven glass fabric copper-clad laminated sheet, as defined in IEC 61249-2-7.

- The nominal sheet thickness shall be 1,6 mm.
- The nominal thickness of copper layer shall be 0,035 mm or 0,070 mm for rated dissipation values above 5 W.

Metal parts of the fuse-base shall be made of brass with a copper content between 58 % and 70 %. Contact parts shall be silver-plated.

When two or more fuse resistors with particular overcurrent protection are tested in series, the test fuse-bases shall be located so that there will be a spacing of not less than 50 mm between any two fuse resistors with particular overcurrent protection. The conductor connecting the test fuse-bases together, and connecting the test fuse-bases to the ammeter and the source of supply shall be insulated copper wire. The length of each conductor shall be 250 mm, and the cross-sectional area of the wire shall be approximately 1 mm².

7.3.2 Through-hole mounting of fuse resistors with particular overcurrent protection

For electrical tests, the fuse resistors with particular overcurrent protection shall be mounted on the test board as shown in Figure 1 in the pair of holes appropriate to the spacing of the terminations.

7.3.3 Surface mounting of fuse resistors with particular overcurrent protection

For electrical tests, the fuse resistors with particular overcurrent protection shall be mounted on the test board as shown in Figure 2.

7.4 Nature of supply

See IEC 60127-1:2006, 7.4.

8 Dimensions and construction

8.1 Dimensions

The requirements of IEC 60127-1:2006, 8.1, are replaced as follows:

- The dimensions of the fuse resistors with particular overcurrent protection shall be as specified by the manufacturer.
- Compliance is checked by measurement of length, width and height.

For through-hole mount fuse resistors with particular overcurrent protection the termination spacing is checked. In addition, the following applies:

- The termination shall also pass through a 1 mm hole.
- The length of the termination is not specified as this is subject to the method of packaging.

8.1.1 Creepage distances and clearances

The creepage distances and clearances between current-carrying parts (contacts together with their terminals) and the outside of the enclosure of the fuse resistor with particular overcurrent protection including insulated metal parts thereof, shall be not less than the values given in Table 1. The values indicated are absolute minimum values and inclusive of manufacturing tolerances.

These distances do not apply across the disconnection (between the open contacts) of the fuse resistors with particular overcurrent protection.

Compliance is checked by measuring the distances concerned.

**Table 1 – Creepage distances and clearances
(absolute minimum values)**

Rated voltage, U_r V	Clearance mm	Creepage distance mm
0 to 32	0,2	0,53
33 to 50	0,2	1,2
51 to 125	0,5	1,5
126 to 250	1,5	2,5
251 to 400	3,0	4,0
401 to 500	4,0	6,9

NOTE 1 The clearances/creepage distances are specified according to IEC 60664-1.

NOTE 2 The values specified are for typical applications of fuse resistors with particular overcurrent protection assuming:

- a) continuous voltage stress;
- b) altitude of 2 000 m;
- c) basic insulation;
- d) inhomogeneous field;
- e) overvoltage category II;
- f) pollution degree 2;
- g) material group III.

NOTE 3 If conditions are different from those specified in Note 2, adjustments in clearances/creepage distances will be necessary as per IEC 60664-1.

8.2 Construction

The requirements of IEC 60127-1:2006, 8.2, are replaced as follows:

The resistor shall be completely enclosed.

8.2.1 The fuse resistor with particular overcurrent protection shall withstand the heat and chemical exposure of a printed circuit board or other substrate assembly operations with its performance unimpaired.

8.2.2 The fuse resistor with particular overcurrent protection shall be resistant to fire according to IEC 60695-2-12 and IEC 60695-2-13.

Compliance is checked by inspection. This is not applicable for fuse resistors with particular overcurrent protection which represent small parts according to IEC 60695-4:2012, 3.78.

For fuse resistor bodies made of plastic material or of material containing organic substances, the following minimum requirements apply:

- Glow-wire ignition temperature (GWIT) = 775 °C
- Glow-wire flammability index (GWFI) = 850 °C

NOTE 1 For the glow wire tests it is necessary to use material plates with dimensions according to IEC 60695-2-12:2010, 4.2 and/or IEC 60695-2-13:2010, 4.2.

NOTE 2 For materials such as glass and ceramic whose GWIT and GWFI are thought to be higher than 775 °C and respectively 850 °C the glow-wire tests do not apply.

8.3 Terminations

The requirements of IEC 60127-1:2006, 8.3, are replaced as follows:

8.3.1 Through-hole mount fuse resistors with particular overcurrent protection

The terminations shall be firmly attached so that it is not possible to remove them without damaging the fuse resistor with particular overcurrent protection.

Compliance is checked by carrying out the following test.

The tests are carried out in accordance with IEC 60068-2-21.

The following tests shall be applied:

- tensile test U_{a1} , applied force 10 N;
- thrust test U_{a2} , applied force 2 N;
- bending test U_b , applied force 5 N, number of bends: 1.

The sample size is two fuse resistors with particular overcurrent protection for each test. After testing, the terminations shall remain firmly attached. The resistance shall be measured in accordance with 9.1, and the change in resistance shall not exceed the value specified by the manufacturer. Bending test U_b is omitted, if the terminations are less than 5 mm.

The samples are then mounted on the test board as shown in Figure 1.

8.3.2 Surface mount fuse resistors with particular overcurrent protection

The fuse resistors with particular overcurrent protection shall be mounted on the test board as shown in Figure 2. The test board, with the fuse resistors with particular overcurrent protection on the underside, shall be placed in the bending jig as shown in Figure 4. The test board shall then be bent by 1 mm at a rate of 1 mm/s. The test board shall be allowed to recover from the bent position, and then be removed from the test jig.

After testing, the terminations shall remain firmly attached. The resistance shall be measured in accordance with 9.1, and the change in resistance shall not exceed the value specified by the manufacturer.

8.4 Alignment and configuration of terminations

The termination configuration and spacing shall be as specified by the manufacturer.

NOTE 1 Through-hole mounting of fuse resistors with particular overcurrent protection.

For through-hole mounting of fuse resistors with particular overcurrent protection, the dimensions specified by the manufacturer should be such as to permit installation on printed circuit boards having a grid system of holes located on centres of distance $e = 2,5$ mm. Attention is drawn to the fact that in some parts of the world the value $e = 2,54$ mm is still in use by printed circuit designers.

Electrical and electronic circuit designers are advised to apply the requirements of IEC 60326-3 (withdrawn).

NOTE 2 Surface mounting of fuse resistors with particular overcurrent protection

For surface mounting of fuse resistors with particular overcurrent protection, electrical and electronic circuit designers are advised to design substrate land areas to receive the fuse resistor with particular overcurrent protection with due consideration for achieving the maximum area of contact in the application, taking into account the tolerance applied to mechanical placing of the component and the dimensions and tolerances for terminals in this standard.

8.5 Soldered joints

No test specified.

8.6 Solderability of terminations

No test specified.

8.7 Resistance to soldering heat

No test specified.

9 Electrical requirements

The requirements of IEC 60127-1:2006, Clause 9, are replaced as follows:

9.1 Resistance value

The samples are drawn at random and numbered consecutively (without being sorted in descending order of resistance value). The resistance value shall be measured at the points marked U in Figure 1 for through-hole mount fuse resistors with particular overcurrent protection and in Figure 2 for surface mount fuse resistors with particular overcurrent protection, using the test fuse-base shown in Figure 3 (see 7.3).

Resistance values including tolerances as specified by the manufacturer apply.

9.2 Functioning characteristic at the minimum breaking dissipation

9.2.1 Functioning characteristic at an ambient temperature of 70 °C

The breaking dissipation across the fuse resistor with particular overcurrent protection shall be adjusted to within $\pm 1\%$ of the value required in this standard. The breaking dissipation stability during the test shall be maintained within $\pm 1\%$ of the adjusted value.

The accuracy of the measurement of time shall be within a tolerance of $\pm 5\%$ for times of less than 10 s and $\pm 2\%$ for times of 10 s or more.

Compliance is checked as follows:

- a) The samples are exposed in the test oven to a temperature of 70_{-5}^{+0} until the temperature has stabilized, shown when two consecutive readings are equal within 1 K.
- b) After stabilization of the test oven at 70 °C, an initial load of 16 times the rated dissipation is applied across the sample.
- c) The temperature rise, as measured on the terminations where they enter the test board, shall not exceed 180 °C or 135 K taking into account the standard use of SnAgCu or SnCu based solders.
- d) In addition, the measured operating times shall not exceed the maximum values specified by the manufacturer and shall be not more than 60 s.

e) Subsequent assessment according to 9.3.2 and testing according to 9.3.3 and 9.3.3.1.

9.2.2 Test at elevated temperature

None specified.

9.2.3 Test procedure

The requirements of IEC 60127-1:2006, 9.2.3, are replaced as follows:

Direct current shall be used for these tests.

NOTE Direct current is used because it is easier to control and eliminates the variation inherent with alternating current caused by the point on the voltage wave that switching occurs.

9.2.4 Presentation of results

Not applicable.

9.3 Rated breaking capacity

The requirements of IEC 60127-1:2006, 9.3, are replaced as follows:

Fuse resistors with particular overcurrent protection shall operate satisfactorily without endangering the surroundings when breaking a rated current of 35 A.

The recovery voltage shall be between 1,05 and 1,05¹ times the rated voltage of the fuse resistor with particular overcurrent protection and shall be maintained for 30 s after operation.

For the breaking capacity test, the current shall be adjusted by changing the series resistance.

The impedance of the a.c. source shall be less than 10 % of the adjusted value of the total impedance of the applicable circuit.

Compliance is checked as follows:

- a) The samples are exposed in the test oven to a temperature of 70⁺⁰₋₅ until the temperature has stabilized, shown when two consecutive readings are equal within 1 K.
- b) Then the breaking capacity of 35 A is tested with a.c. and/or d.c. and with random closing angle.

NOTE The breaking capacity may be lower with d.c. than with a.c. It is influenced by the circuit inductance and, with a.c., additionally by the instant of closing the circuit.

9.3.1 In the case of fuse resistors with particular overcurrent protection in which any component is organic (such as with a moulded body), the recovery voltage shall be maintained for 5 min after operation.

Typical test circuits for a.c. and d.c. are given in Figure 5.

For fuse resistors with particular overcurrent protection, the power factor of the a.c. test circuit shall be greater than 0,95. To obtain this result, the circuit current shall be adjusted by the use of resistors of negligible inductance.

¹ This tolerance may be exceeded with the manufacturer's consent.

The time constant of the d.c. test circuit shall be less than 1 ms. To obtain this result, the circuit current shall be adjusted by the use of resistors of negligible inductance. Additionally, the total inductance of the test circuit and source of supply shall be less than 1 mH.

Where difficulties in testing arise, these limits may be exceeded with the permission of the manufacturer. For tests at lower prospective currents, the inductance of the circuit shall remain constant and the current shall be adjusted by changing the resistance only.

9.3.2 Criteria for satisfactory performance

The requirements of IEC 60127-1:2006, 9.3.2, are replaced as follows:

The fuse resistor with particular overcurrent protection shall operate satisfactorily without any of the following phenomena:

- permanent arcing;
- ignition;
- bursting of the fuse resistor with particular overcurrent protection;
- illegibility of marking after test.

The following phenomena are neglected:

- black spots or other marks on the terminations or the body of the fuse resistor with particular overcurrent protection;
- arcing times of less than 1 ms.

9.3.3 Insulation resistance

The requirements of IEC 60127-1:2006, 9.3.3, are replaced as follows:

After the breaking capacity test, the insulation resistance shall be measured with a d.c. voltage equal to twice the rated voltage of the fuse resistor with particular overcurrent protection, but not less than 500 V d.c.

The samples are deemed to comply with the requirements, if the insulation resistance measured for 1 min across the disconnection is not less than 0,1 MΩ and, if applicable, between the current path and the enclosure is not less than 2 MΩ.

9.3.3.1 Dielectric strength

Immediately after the test of 9.3.3, a test voltage according to Table 2 is applied for 1 min across the disconnection and, if applicable, between the current path and the enclosure wrapped in metal foil.

The test samples are deemed to comply with the requirements, if no flashover or breakdown occurs.

Table 2 – Test voltages for dielectric strength

Between	Test voltage
Live parts and enclosure	$2 U_r + 1\,000\text{ V}$
Disconnection (between open contacts)	$2 U_r$

9.4 Endurance tests

None specified.

9.5 Maximum sustained dissipation

No test specified.

9.6 Pulse tests

None specified.

9.7 Temperature of fuse resistors with particular overcurrent protection

No test specified.

9.8 Operating overvoltage

During the breaking capacity test, the voltage across the fuse resistor with particular overcurrent protection shall be monitored by a suitable oscilloscope and probe system, operated in such a way as to indicate and record the voltage for a time which includes the interval from the moment of closure of the contactor until current through the fuse resistor with particular overcurrent protection is extinguished to a value of less than 10 mA (a suitable oscilloscope should be capable of recording any overvoltage that persists for 5 μ s or longer).

The maximum voltage in the interval shall be recorded. In no case shall it be higher than the maximum continuous voltage given on the manufacturer's data sheet.

NOTE Voltage peaks with a duration of $\leq 20 \mu$ s are neglected.

Dimensions in millimetres

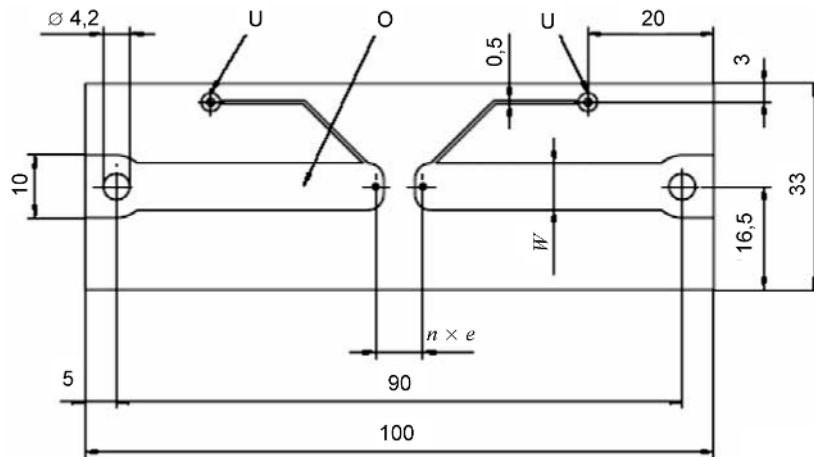

Key

O copper layer, thickness 0,035 mm (0,070 mm for rated dissipation equal to or above 5 W)

U connection for resistance measurement

n 1, 2, 3, 4 or 5

e 2,50 mm

W 5,0 mm for rated dissipation up to 5 W

7,5 mm for rated dissipation equal to or above 5 W

NOTE A mechanical device may be used as long as it is demonstrated that the results are the same.

Figure 1 – Test board for through-hole mount fuse resistors with particular overcurrent protection

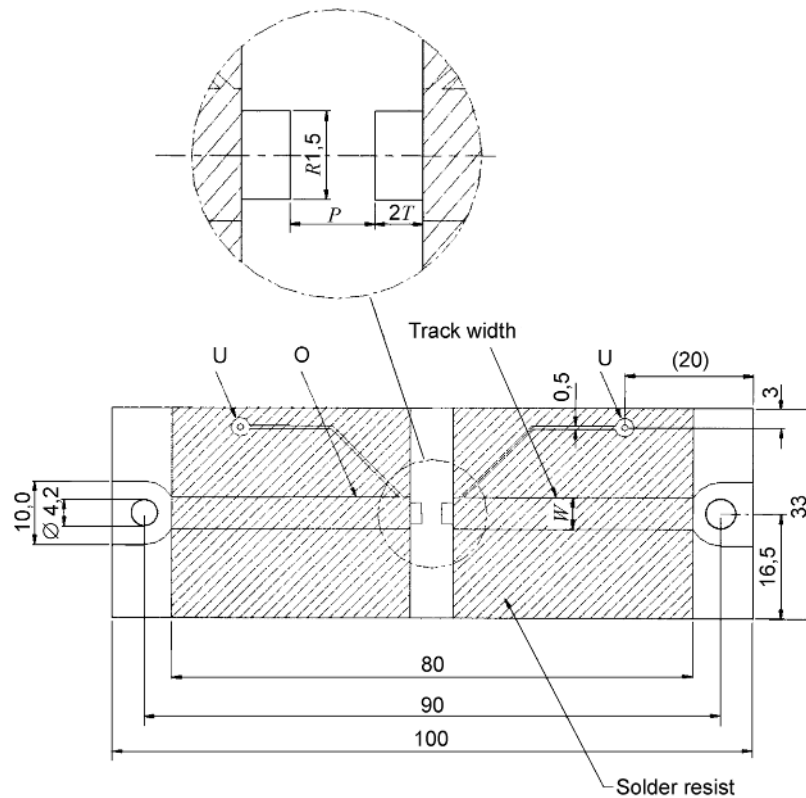
**Key**

O copper layer, thickness 0,035 mm (0,070 mm for rated dissipation equal to or above 5 W)

U connection for resistance measurement

W 5,0 mm (7,5 mm for rated dissipation equal to or above 5 W). For small fuse resistors with particular overcurrent protection, it may be necessary to use reduced track width, representing normal use of these devices. This should be recorded in the test report and in the manufacturer's literature.

P terminal spacing

R as specified by the manufacturer

T as specified by the manufacturer

NOTE 1 Solder resist to be applied in hatched areas.

NOTE 2 The land areas should be suitably prepared for soldering.

NOTE 3 A mechanical device may be used as long as it is demonstrated that the results are the same.

Figure 2 – Test board for surface mount fuse resistors with particular overcurrent protection

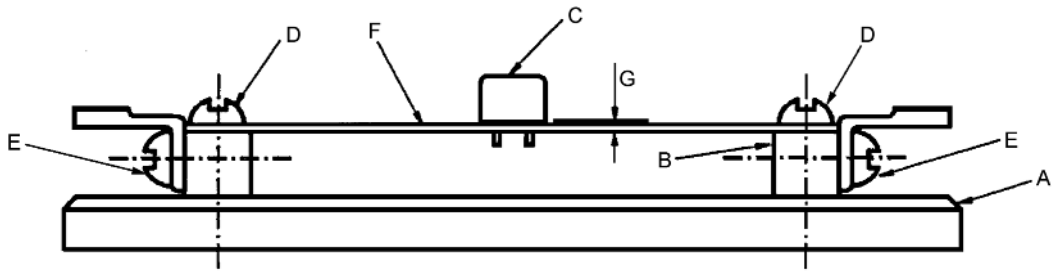

Figure 3a – Through-hole mount fuse resistor with particular overcurrent protection (printed circuit track underneath)

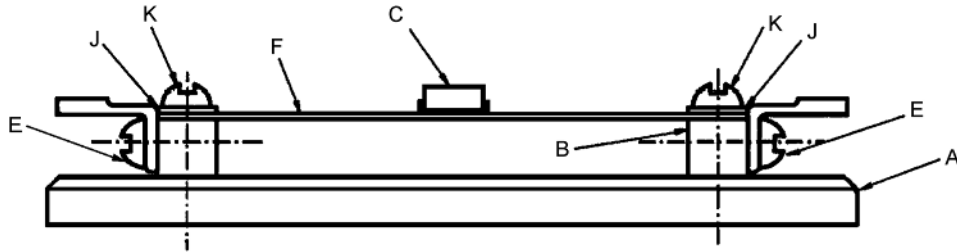
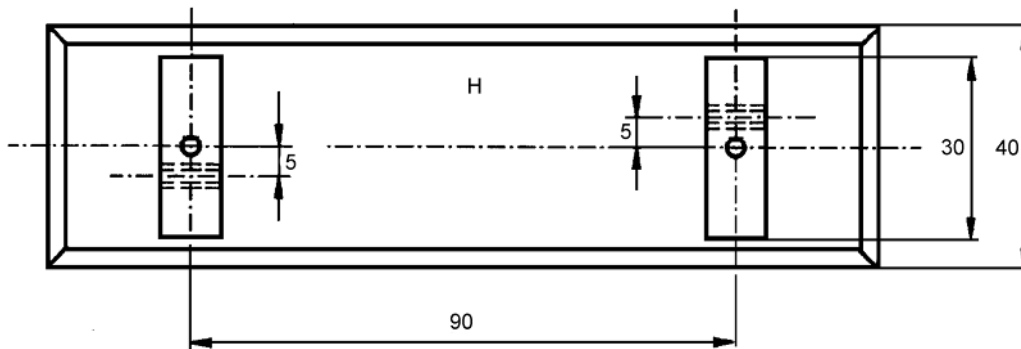

Figure 3b – Surface mount fuse resistor with particular overcurrent protection (printed circuit track on top)

Dimensions in millimetres



Key

- | | |
|--|--|
| A base of low heat conducting material, thickness 10 mm | G space between enclosure of the fuse resistor with particular overcurrent protection and circuit board as specified by the manufacturer |
| B brass electrodes, 10 mm × 10 mm | H top view of base with brass electrodes |
| C fuse resistor with particular overcurrent protection soldered in place | J silver-plated brass washer (two places) |
| D fixing screws | K silver-plated brass screw to make contact with the conducting surface on top of the printed circuit board (two places) |
| E contact screws holding solder terminal | |
| F printed circuit board (see Figure 1 and Figure 2) | |

Figure 3 – Test fuse-base

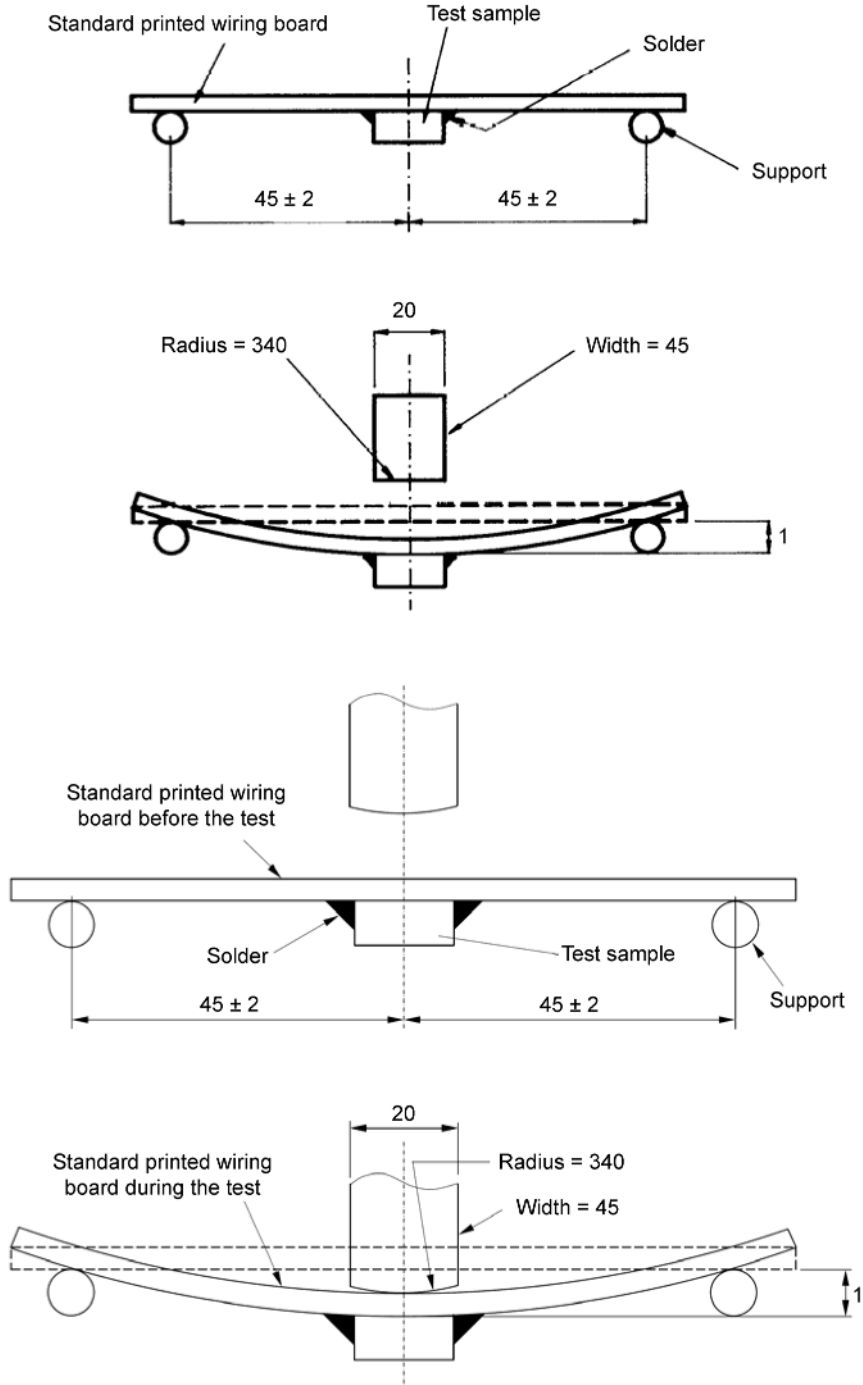
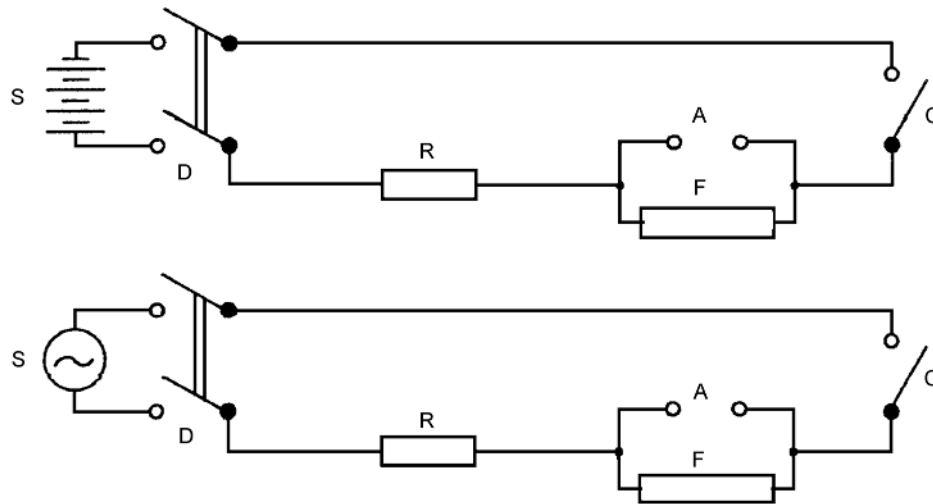

Figure 4 – Bending jig for surface mount fuse resistors with particular overcurrent protection



Components

- A removable link used for calibration
- C contactor that makes the circuit
- D switch to disconnect the source of supply
- F fuse resistor with particular overcurrent protection under test
- S source of supply, impedance less than 10 % of the total impedance of the circuit
- R series resistor, adjusted to obtain correct prospective current

Figure 5 – Test circuit for the tests according to 9.3

Bibliography

IEC 60068-2-58:2004, *Environmental testing – Part 2-58: Tests – Test Td: Test methods for solderability, resistance to dissolution of metallization and to soldering heat of surface mounting devices (SMD)*

IEC 60115-1:2008, *Fixed resistors for use in electronic equipment – Part 1: Generic specification*

IEC 60115-4-101:1995, *Fixed resistors for use in electronic equipment – Part 4: Detail specification: Fixed power wirewound resistors with solderable axial wire leads – Stability class 5%. Assessment level E*

IEC 60115-4-102:1995, *Fixed resistors for use in electronic equipment – Part 4: Detail specification: Fixed power wirewound resistors with solderable axial wire leads – Stability class 1 % – Assessment level E²*

IEC 60115-4:1982, *Fixed resistors for use in electronic equipment. Part 4: Sectional specification: Fixed power resistors*

IEC 60664-1:2007, *Insulation coordination for equipment within low-voltage systems – Part 1: Principles, requirements and tests*

IEC 61190-1-2, *Attachment materials for electronic assembly – Part 1-2: Requirements for soldering pastes for high-quality interconnects in electronics assembly*

NOTE Harmonized as EN 61190-1-2:2007 (not modified).

IEC 61191-2:2013, *Printed board assemblies – Part 2: Sectional specification – Requirements for surface mount soldered assemblies*

NOTE Harmonized as EN 61191-2:2013 (not modified).

IEC 60326-3:1991, *Printed boards – Part 3: Design and use of printed boards²*

ISO 3:1973, *Preferred numbers – Series of preferred numbers*

ISO 9453:1990, *Soft solder alloys – Chemical composition and forms*

NOTE Harmonized as EN 29453:1993 (not modified).

DIN EN 60115-8, *Festwiderstände zur Verwendung in Geräten der Elektronik – Teil 8: Rahmenspezifikation – Oberflächenmontierbare (SMD) Festwiderstände*

DIN IEC 60115-2:2009, *Festwiderstände zur Verwendung in Geräten der Elektronik – Teil 2: Rahmenspezifikation – Niedrig belastbare nichtdrahtgewickelte Festwiderstände*

² This standard has been withdrawn and not replaced.

British Standards Institution (BSI)

BSI is the national body responsible for preparing British Standards and other standards-related publications, information and services.

BSI is incorporated by Royal Charter. British Standards and other standardization products are published by BSI Standards Limited.

About us

We bring together business, industry, government, consumers, innovators and others to shape their combined experience and expertise into standards-based solutions.

The knowledge embodied in our standards has been carefully assembled in a dependable format and refined through our open consultation process. Organizations of all sizes and across all sectors choose standards to help them achieve their goals.

Information on standards

We can provide you with the knowledge that your organization needs to succeed. Find out more about British Standards by visiting our website at bsigroup.com/standards or contacting our Customer Services team or Knowledge Centre.

Buying standards

You can buy and download PDF versions of BSI publications, including British and adopted European and international standards, through our website at bsigroup.com/shop, where hard copies can also be purchased.

If you need international and foreign standards from other Standards Development Organizations, hard copies can be ordered from our Customer Services team.

Subscriptions

Our range of subscription services are designed to make using standards easier for you. For further information on our subscription products go to bsigroup.com/subscriptions.

With **British Standards Online (BSOL)** you'll have instant access to over 55,000 British and adopted European and international standards from your desktop. It's available 24/7 and is refreshed daily so you'll always be up to date.

You can keep in touch with standards developments and receive substantial discounts on the purchase price of standards, both in single copy and subscription format, by becoming a **BSI Subscribing Member**.

PLUS is an updating service exclusive to BSI Subscribing Members. You will automatically receive the latest hard copy of your standards when they're revised or replaced.

To find out more about becoming a BSI Subscribing Member and the benefits of membership, please visit bsigroup.com/shop.

With a **Multi-User Network Licence (MUNL)** you are able to host standards publications on your intranet. Licences can cover as few or as many users as you wish. With updates supplied as soon as they're available, you can be sure your documentation is current. For further information, email bsmusales@bsigroup.com.

BSI Group Headquarters

389 Chiswick High Road London W4 4AL UK

Revisions

Our British Standards and other publications are updated by amendment or revision.

We continually improve the quality of our products and services to benefit your business. If you find an inaccuracy or ambiguity within a British Standard or other BSI publication please inform the Knowledge Centre.

Copyright

All the data, software and documentation set out in all British Standards and other BSI publications are the property of and copyrighted by BSI, or some person or entity that owns copyright in the information used (such as the international standardization bodies) and has formally licensed such information to BSI for commercial publication and use. Except as permitted under the Copyright, Designs and Patents Act 1988 no extract may be reproduced, stored in a retrieval system or transmitted in any form or by any means – electronic, photocopying, recording or otherwise – without prior written permission from BSI. Details and advice can be obtained from the Copyright & Licensing Department.

Useful Contacts:

Customer Services

Tel: +44 845 086 9001

Email (orders): orders@bsigroup.com

Email (enquiries): cservices@bsigroup.com

Subscriptions

Tel: +44 845 086 9001

Email: subscriptions@bsigroup.com

Knowledge Centre

Tel: +44 20 8996 7004

Email: knowledgecentre@bsigroup.com

Copyright & Licensing

Tel: +44 20 8996 7070

Email: copyright@bsigroup.com



...making excellence a habit.™