

PD CEN ISO/TS 9241-411:2014



BSI Standards Publication

Ergonomics of human-system interaction

Part 411: Evaluation methods for the
design of physical input devices

bsi.

...making excellence a habit.™

National foreword

This Published Document is the UK implementation of CEN ISO/TS 9241-411:2014. It is identical to ISO/TS 9241-411:2012. It supersedes PD ISO/TS 9241:411:2012, which is withdrawn. Together with BS EN ISO 9241-400:2007, BS EN ISO 9241-410:2008+A1:2012, and BS EN ISO 9241-420:2011, it supersedes BS EN ISO 9241-4:1998 and BS EN ISO 9241-9:2000, which are withdrawn.

The UK participation in its preparation was entrusted to Technical Committee PH/9, Applied ergonomics.

A list of organizations represented on this committee can be obtained on request to its secretary.

This publication does not purport to include all the necessary provisions of a contract. Users are responsible for its correct application.

© The British Standards Institution 2014.
Published by BSI Standards Limited 2014

ISBN 978 0 580 86093 5

ICS 13.180; 35.180

Compliance with a British Standard cannot confer immunity from legal obligations.

This Published Document was published under the authority of the Standards Policy and Strategy Committee on 31 July 2012.

Amendments/corrigenda issued since publication

Date	Text affected
30 September 2014	This corrigendum renumbers PD ISO/TS 9241-411:2012 as PD CEN ISO/TS 9241-411:2014. Supersession information in national foreword also updated

ICS 35.180; 13.180

English Version

**Ergonomics of human-system interaction - Part 411: Evaluation
methods for the design of physical input devices (ISO/TS 9241-
411:2012)**

Ergonomie de l'interaction homme-système - Partie 411:
Méthodes d'évaluation de la conception des dispositifs
d'entrée physiques (ISO/TS 9241-411:2012)

Ergonomie der Mensch-System-Interaktion - Teil 411:
Bewertungsverfahren für die Gestaltung von physikalischen
Eingabegeräten (ISO/TS 9241-411:2012)

This Technical Specification (CEN/TS) was approved by CEN on 28 June 2014 for provisional application.

The period of validity of this CEN/TS is limited initially to three years. After two years the members of CEN will be requested to submit their comments, particularly on the question whether the CEN/TS can be converted into a European Standard.

CEN members are required to announce the existence of this CEN/TS in the same way as for an EN and to make the CEN/TS available promptly at national level in an appropriate form. It is permissible to keep conflicting national standards in force (in parallel to the CEN/TS) until the final decision about the possible conversion of the CEN/TS into an EN is reached.

CEN members are the national standards bodies of Austria, Belgium, Bulgaria, Croatia, Cyprus, Czech Republic, Denmark, Estonia, Finland, Former Yugoslav Republic of Macedonia, France, Germany, Greece, Hungary, Iceland, Ireland, Italy, Latvia, Lithuania, Luxembourg, Malta, Netherlands, Norway, Poland, Portugal, Romania, Slovakia, Slovenia, Spain, Sweden, Switzerland, Turkey and United Kingdom.



EUROPEAN COMMITTEE FOR STANDARDIZATION
COMITÉ EUROPÉEN DE NORMALISATION
EUROPÄISCHES KOMITEE FÜR NORMUNG

CEN-CENELEC Management Centre: Avenue Marnix 17, B-1000 Brussels

Foreword

The text of ISO/TS 9241-411:2012 has been prepared by Technical Committee ISO/TC 159 “Ergonomics” of the International Organization for Standardization (ISO) and has been taken over as CEN ISO/TS 9241-411:2014 by Technical Committee CEN/TC 122 “Ergonomics” the secretariat of which is held by DIN.

Attention is drawn to the possibility that some of the elements of this document may be the subject of patent rights. CEN [and/or CENELEC] shall not be held responsible for identifying any or all such patent rights.

According to the CEN-CENELEC Internal Regulations, the national standards organizations of the following countries are bound to announce this Technical Specification: Austria, Belgium, Bulgaria, Croatia, Cyprus, Czech Republic, Denmark, Estonia, Finland, Former Yugoslav Republic of Macedonia, France, Germany, Greece, Hungary, Iceland, Ireland, Italy, Latvia, Lithuania, Luxembourg, Malta, Netherlands, Norway, Poland, Portugal, Romania, Slovakia, Slovenia, Spain, Sweden, Switzerland, Turkey and the United Kingdom.

Endorsement notice

The text of ISO/TS 9241-411:2012 has been approved by CEN as CEN ISO/TS 9241-411:2014 without any modification.

Contents

Page

Foreword	v
Introduction.....	viii
1 Scope	1
2 Normative references	1
3 Terms and definitions	2
4 Guiding principles	7
5 Evaluation methods	7
5.1 Physical input devices in general.....	7
5.2 Keyboards	10
5.3 Mice.....	22
5.4 Pucks	25
5.5 Joysticks	28
5.6 Trackballs	31
5.7 Touchpads	34
5.8 Tablets and overlays	37
5.9 Styli and light-pens	40
5.10 Touch-sensitive screens.....	42
6 Conformance	42
Annex A (informative) Overview of the ISO 9241 series	43
Annex B (informative) Testing of efficiency and effectiveness.....	44
Annex C (informative) Assessment of comfort.....	51
Annex D (informative) Usability test for keyboards	56
Bibliography.....	62
Figures	
Figure 1 — Side view of example joystick	3
Figure 2 — Example of light-pen against display	4
Figure 3 — Top view of example of tablet with graphic overlay.....	4
Figure 4 — Top view examples of two types of puck	5
Figure 5 — Side view of example of stylus over graphics tablet	5
Figure 6 — Example of top view of trackball device with buttons	6
Figure 7 — Illustration of flat, concave and convex keytops.....	14
Figure 8 — Measurement of keytop width and depth	14
Figure 9 — Measurement of key displacement	14
Figure 10 — Relationship between key displacement and key force (ISO 9241-410:2008, Figure B.3) ..	15
Figure 11 — Measurement of character height	15
Figure 12 — Measurement of vertical and horizontal distance between two adjacent keys.....	17
Figure 13 — Measurement of slope of keyboard	18
Figure 14 — Numeric keypad layout	18
Figure B.1 — Relationship of index of difficulty to time	47
Figure B.2 — One-direction tapping task.....	48

Figure B.3 — Multi-directional pointing task 49
Figure B.4 — Tracing task 50

Tables

Table 1 — Measuring methods on physical input devices in general..... 7
Table 2 — Requirements on the generic operability of keyboards 10
Table 3 — Requirements for functional properties of full-size keyboards 10
Table 4 — Requirements for sections and zones of full-size keyboards..... 16
Table 5 — Requirements for the mechanical design of full-size keyboards 17
Table 6 — Requirements for maintainability of full-size keyboards..... 18
Table 7 — Requirements for documentation of full-size keyboards 19
Table 8 — Requirements for design of keys of compact keyboards 19
Table 9 — Requirements for sections and zones of compact keyboards 20
Table 10 — Requirements for mechanical design of compact keyboards 20
Table 11 — Requirements for maintainability of compact keyboards 21
Table 12 — Requirements for documentation of compact keyboards..... 22
Table 13 — Mouse design requirements 22
Table 14 — Design requirements for pucks..... 25
Table 15 — Design requirements for joysticks..... 28
Table 16 — Design requirements for trackballs 31
Table 17 — Design requirements for touchpads..... 34
Table 18 — Design requirements for tablets and overlays 37
Table 19 — Design requirements for styli and light-pens 40
Table 20 — Design requirements for touch-sensitive screens..... 42
Table A.1 — Structure of ISO 9241 — Ergonomics of human–system interaction..... 43
Table B.1 — Task and condition variations 45
Table C.1 — Independent rating scale..... 52
Table C.2 — Dependent rating scale..... 53
Table C.3 — Borg scale..... 54
Table C.4 — Borg scale for arm, shoulder, and neck effort 54
Table D.1 — Reflectance of surfaces 58
Table D.2 — Independent rating scale..... 60
Table D.3 — Example of material for data entry (English language)..... 61

Foreword

ISO (the International Organization for Standardization) is a worldwide federation of national standards bodies (ISO member bodies). The work of preparing International Standards is normally carried out through ISO technical committees. Each member body interested in a subject for which a technical committee has been established has the right to be represented on that committee. International organizations, governmental and non-governmental, in liaison with ISO, also take part in the work. ISO collaborates closely with the International Electrotechnical Commission (IEC) on all matters of electrotechnical standardization.

International Standards are drafted in accordance with the rules given in the ISO/IEC Directives, Part 2.

The main task of technical committees is to prepare International Standards. Draft International Standards adopted by the technical committees are circulated to the member bodies for voting. Publication as an International Standard requires approval by at least 75 % of the member bodies casting a vote.

In other circumstances, particularly when there is an urgent market requirement for such documents, a technical committee may decide to publish other types of document:

- an ISO Publicly Available Specification (ISO/PAS) represents an agreement between technical experts in an ISO working group and is accepted for publication if it is approved by more than 50 % of the members of the parent committee casting a vote;
- an ISO Technical Specification (ISO/TS) represents an agreement between the members of a technical committee and is accepted for publication if it is approved by 2/3 of the members of the committee casting a vote.

An ISO/PAS or ISO/TS is reviewed after three years in order to decide whether it will be confirmed for a further three years, revised to become an International Standard, or withdrawn. If the ISO/PAS or ISO/TS is confirmed, it is reviewed again after a further three years, at which time it must either be transformed into an International Standard or be withdrawn.

Attention is drawn to the possibility that some of the elements of this document may be the subject of patent rights. ISO shall not be held responsible for identifying any or all such patent rights.

ISO/TS 9241-411 was prepared by Technical Committee ISO/TC 159, *Ergonomics*, Subcommittee SC 4, *Ergonomics of human-system interaction*.

This first edition of ISO/TS 9241-411, together with ISO 9241-400, ISO 9241-410 and ISO 9241-420, cancels and replaces ISO 9241-4 and ISO 9241-9, technically revised as follows:

- terms and definitions from ISO 9241-4 and ISO 9241-9 have been transferred to ISO 9241-400;
- guiding principles, collected in ISO 9241-400, have been incorporated and unified so that they correspond to the scope of the new ISO 9241 series;
- test methods taken from ISO 9241-4 and ISO 9241-9 have been reviewed and amended and new test methods introduced and collected in annexes for greater convenience.

ISO/TS 9241 consists of the following parts, under the general title *Ergonomic requirements for office work with visual display terminals (VDTs)*:

- *Part 1: General introduction*
- *Part 2: Guidance on task requirements*

- *Part 5: Workstation layout and postural requirements*
- *Part 6: Guidance on the work environment*
- *Part 11: Guidance on usability*
- *Part 12: Presentation of information*
- *Part 13: User guidance*
- *Part 14: Menu dialogues*
- *Part 15: Command dialogues*
- *Part 16: Direct manipulation dialogues*
- *Part 17: Form filling dialogues*

ISO 9241 also consists of the following parts, under the general title *Ergonomics of human-system interaction*:

- *Part 20: Accessibility guidelines for information/communication technology (ICT) equipment and services*
- *Part 100: Introduction to standards related to software ergonomics [Technical Report]*
- *Part 110: Dialogue principles*
- *Part 129: Guidance on software individualization*
- *Part 143: Forms*
- *Part 151: Guidance on World Wide Web user interfaces*
- *Part 154: Interactive voice response (IVR) applications*
- *Part 171: Guidance on software accessibility*
- *Part 210: Human-centred design for interactive systems*
- *Part 300: Introduction to electronic visual display requirements*
- *Part 302: Terminology for electronic visual displays*
- *Part 303: Requirements for electronic visual displays*
- *Part 304: User performance test methods for electronic visual displays*
- *Part 305: Optical laboratory test methods for electronic visual displays*
- *Part 306: Field assessment methods for electronic visual displays*
- *Part 307: Analysis and compliance test methods for electronic visual displays*
- *Part 308: Surface-conduction electron-emitter displays (SED) [Technical Report]*
- *Part 309: Organic light-emitting diode (OLED) displays [Technical Report]*
- *Part 310: Visibility, aesthetics and ergonomics of pixel defects [Technical Report]*
- *Part 331: Optical characteristics of autostereoscopic displays [Technical Report]*
- *Part 400: Principles and requirements for physical input devices*
- *Part 410: Design criteria for physical input devices*

- *Part 411: Evaluation methods for the design of physical input devices* [Technical Specification]
- *Part 420: Selection of physical input devices*
- *Part 910: Framework for tactile and haptic interaction*
- *Part 920: Guidance on tactile and haptic interactions*

The following parts are under preparation:

- *Part 391: Requirements, analysis and compliance test methods for the reduction of photosensitive seizures*

User-interface elements, ergonomic requirements for the reduction of visual fatigue from stereoscopic images, and the evaluation of tactile and haptic interactions are to form the subjects of future parts 161, 392 and 940.

Introduction

Input devices are a means for users to enter data into interactive systems. Generally speaking, an input device is a sensor that can detect changes in user behaviour (gestures, moving fingers, etc.) and transform them into signals to be interpreted by the interactive system.

This part of ISO 9241 presents methods for the laboratory analysis and comparison of input devices for interactive systems. It does not contain requirements for input devices, but provides the means for evaluating conformance with the requirements of ISO 9241-410 for input devices such as keyboards, mice, pucks, joysticks, trackballs, touch pads, tablets/overlays, touch-sensitive screens, and styli/light pens.

The target users of this part of ISO 9241 are manufacturers, product designers and test organizations concerned with commercial input devices such as the physical input devices listed above.

Ergonomics of human-system interaction —

Part 411:

Evaluation methods for the design of physical input devices

1 Scope

This part of ISO 9241 specifies evaluation methods for the design of physical input devices for interactive systems. It provides guidance for the laboratory assessment of conformance with ISO 9241-410 for keyboards, mice, pucks, joysticks, trackballs, touch pads, tablets/overlays, touch-sensitive screens, and styli/light pens. Its provisions apply only to keyboards identified as “full-size” or “compact” by the manufacturer, but nevertheless could provide useful guidance in the design of other keyboards. It is not applicable to those of the requirements of ISO 9241-410 that relate to gesture- and voice-input systems.

2 Normative references

The following referenced documents are indispensable for the application of this document. For dated references, only the edition cited applies. For undated references, the latest edition of the referenced document (including any amendments) applies.

ISO 7000, *Graphical symbols for use on equipment — Index and synopsis*¹⁾

ISO 9241-5, *Ergonomic requirements for office work with visual display terminals (VDTs) — Part 5: Workstation layout and postural requirements*

ISO 9241-307, *Ergonomics of human-system interaction — Part 307: Analysis and compliance test methods for electronic visual displays*

ISO 9241-410:2008, *Ergonomics of human-system interaction — Part 410: Design criteria for physical input devices*

ISO/IEC 9995-1, *Information technology — Keyboard layouts for text and office systems — Part 1: General principles governing keyboard layouts*

IEC 60417, *Graphical symbols for use on equipment*¹⁾

1) The database on Graphical Symbols for Use on Equipment contains the complete set of graphical symbols included in ISO 7000 and IEC 60417: <http://www.graphical-symbols.info/>

3 Terms and definitions

For the purposes of this document, the terms and definitions given in ISO 9241-400 and ISO 9241-410 and the following apply.

3.1

category

part of a system into which properties of entities can be arranged

[SOURCE: ISO 9241-410:2008; 3.2]

3.2

class

category of a property of a product with rank order

NOTE 1 Class 1 is the *most*, and class *n* the *least*, favourable category of a specific property of a product, where *n* is the number of classes.

NOTE 2 An example of a property is *durability of the legends* of a key. If a key belongs to the highest class, it will fulfil all requirements for the lower categories.

[SOURCE: ISO 9241-410:2008; 3.3]

3.3

compact keyboard

keyboard that features most properties of a full-size keyboard, with the editing section integrated into the alphanumeric section

NOTE 1 A compact keyboard has no numeric section separate from the alpha keys.

NOTE 2 Compact is a term used to describe a keyboard that allows a mouse or other pointing device to be positioned closer to the user as described in 9241-410, B.2.1.1. Some keyboards, for example keyboards with small dimensions as used on portable devices, are neither full-size nor compact keyboards.

[SOURCE: ISO 9241-410:2008, 3.4, modified — Note 1 has been changed and Note 2 added.]

3.4

full-size keyboard

keyboard that comprises all sections and zones as described in ISO/IEC 9995-1

[SOURCE: ISO 9241-410:2008, 3.6]

3.5

housing

protective cover designed to contain or support a mechanical component

NOTE An input device is either integrated into its own housing or into another unit that comprises other functional units (e.g. control desk, control panel, telephone).

[SOURCE: ISO 9241-410:2008, 3.11]

3.6

index of difficulty

I_D

measure of the user precision required in a task

NOTE The index of difficulty, I_D , is measured in bits, and is calculated for selection, pointing, or dragging tasks by

$$I_D = \log_2 \frac{d + w}{w}$$

and, for tracing tasks, by

$$I_D = \frac{d}{w}$$

where

d is the distance of movement to the target;

w is the target width of the displayed target along the approach axis for selection, pointing or dragging tasks, and perpendicular for tracing tasks.

[SOURCE: ISO 9241-410:2008; 3.12]

3.7 input device

user controlled device that transmits information to a system

[SOURCE: ISO 9241-400:2007; 3.6.3]

3.8 joystick

lever mounted in a fixed base used to control the movement of objects displayed on a screen

SEE: Figure 1.

[SOURCE: ISO 9241-400:2007; 3.6.4]

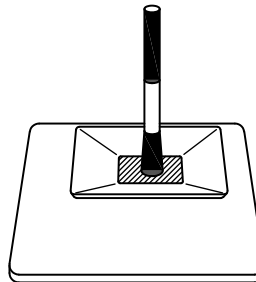

Figure 1 — Side view of example joystick

3.9 keypad

functional unit that comprises at least a group of keys dedicated and arranged for a given functionality and possibly additional keys supporting related functionality

EXAMPLE Numeric keys, “Enter” key of keypad.

[SOURCE: ISO 9241-410:2008; 3.14]

3.10 light-pen

light sensitive input device that, when pointed onto a specific location on a display, identifies its position to the system

SEE: Figure 2.

[SOURCE: ISO 9241-400:2007; 3.6.10]

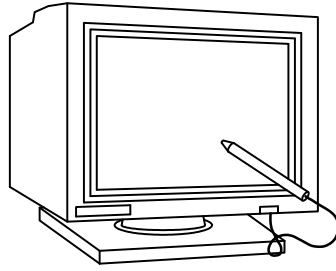

Figure 2 — Example of light-pen against display

3.11
mouse

computer input device having one or more buttons and capable of two dimensional rolling motion which can drive a cursor on the display and performs a variety of selection options or commands

[SOURCE: ISO 9241-400:2007; 3.6.11]

3.12
neutral posture

posture which avoids the extremes of a joint's range of motion or that is not near the end of the range of motion for the particular joint

3.13
overlay

thin template on the surface of a tablet used to indicate the graphic functions available to the user

SEE: Figure 3.

[SOURCE: ISO 9241-400:2007; 3.6.13]

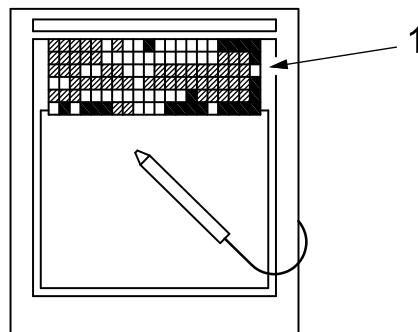

Key

1 graphic overlay

Figure 3 — Top view of example of tablet with graphic overlay

3.14
puck

hand-held device similar to a mouse but with a reticle view port and that is typically used with a digitizing tablet

SEE: Figure 4.

[SOURCE: ISO 9241-400:2007; 3.6.16]

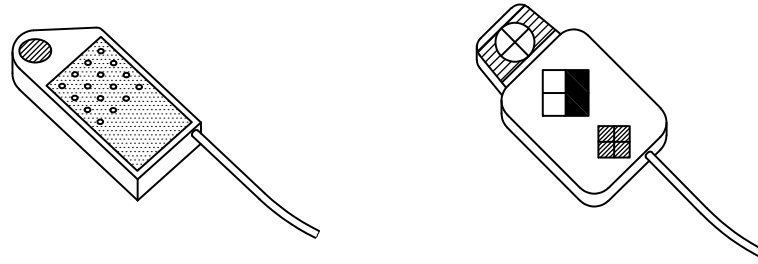

Figure 4 — Top view examples of two types of puck

**3.15
section**

<keyboard> functional groups within computer keyboards for which different rules for layouts can apply

NOTE Some sections of existing keyboards are arranged according to more-than-century-old conventions.

[SOURCE: ISO 9241-410:2008; 3.16]

**3.16
stylus**

pen-shaped pointing device which, when touched to a display or graphics tablet, can be used to draw images on a display or select displayed objects, typically by depressing the stylus tip or actuating a button located along the side of the stylus

SEE: See Figure 5.

[SOURCE: ISO 9241-400:2007; 3.6.23]

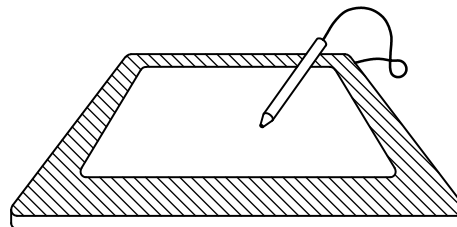

Figure 5 — Side view of example of stylus over graphics tablet

**3.17
tablet
graphics tablet**

special flat surface with an input device (such as a stylus or puck) for selection, drawing, or indicating the position, of images to be displayed

[SOURCE: ISO 9241-400:2007; 3.6.24]

**3.18
task precision**

measure of the accuracy required for a pointing, selecting or dragging task primitive, quantified by the index of difficulty

[SOURCE: ISO 9241-410:2008; 3.17]

3.19
throughput

<input devices> rate of information transfer when a user is operating an input device to control a pointer on a display

NOTE The throughput is expressed in bits per second.

[SOURCE: ISO 9241-400:2007; 3.7.13]

3.20
touch sensitive screen
TSS

input device that produces a position and selection input signal from a finger touching, lifting off or moving across a display

[SOURCE: ISO 9241-400:2007; 3.6.27]

3.21
touchpad

touch-sensitive pad that senses the position of a finger on its surface

[SOURCE: ISO 9241-410:2008; 3.18]

3.22
trackball

input device consisting of a ball in a fixed housing that can be rolled in any direction by the fingers to control pointer movement

NOTE See Figure 6.

[SOURCE: ISO 9241-400:2007; 3.6.26]

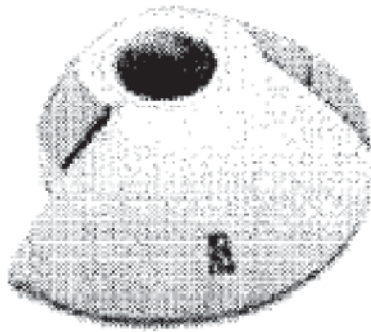

Figure 6 — Example of top view of trackball device with buttons

3.23
zone

<keyboard> smaller unit within a section of a keyboard representing different functionality

EXAMPLE The layout of the alphanumeric keys for entering graphic characters (alphanumeric zone) grouped with function and modifier keys such as "Ctrl", "Alt", "Tab" or "Backspace".

[SOURCE: ISO 9241-410:2008; 3.20]

4 Guiding principles

A structure is needed form compliance procedures and evaluation methods for physical input devices. The aim of this structure is to clarify what requirements and classes (specified in ISO 9241-410) are relevant for each intended application.

For this purpose the evaluation methods are outlined in the Tables 1 to 20. Each table addresses different evaluation methods with three columns stating

- the clauses or subclauses referred to in ISO 9241-410, with the specific requirement being addressed,
- the pass/fail criterion based on the requirements reproduced from ISO 9241-410, and
- the recommended measuring methods to verify whether the requirement has been fulfilled.

Reporting should be done using the summarizing table shown in ISO 9241-410: 2008, Figure 1.

5 Evaluation methods

5.1 Physical input devices in general

Table 1 shows the measuring methods for physical input devices in general.

Table 1 — Measuring methods for physical input devices in general

Attribute in ISO 9241-410: 2008	Pass/Fail criterion based on requirements and intended context of use	Measuring method
Clause 5 Usable for designated purpose	The input device shall be usable for its designated purpose.	Verify the conformance with the normative design requirements in the relevant annex (ISO 9241-410:2008, Annexes B to J).
Clause 5 Satisfactory level of performance	The input device shall be usable for its designated purpose. It is considered usable if users can achieve a satisfactory level of performance on a given task and maintain an acceptable level of effort and satisfaction.	Verify the level of effort and satisfaction by measuring and demonstrating comfort using the methods in Annex C.
7.1 Specification of intended use	The intended use for a physical input device shall be specified unless it is obvious or the device is designed for general purpose use. [Modified from ISO 9241-410]	State: <ul style="list-style-type: none"> — that the intended use is specified; or — that the intended use is for general purposes; or — that the intended use is obvious.
7.1 Technical conditions for use	The specification shall include technical conditions for the context of use to be realized for a satisfactory use of the device (e.g. operating system, driver, support surface, etc.).	Verify that the specification of the intended use of the device states the required technical conditions for the context of use.

Table 1 (continued)

Attribute in ISO 9241-410:2008	Pass/Fail criterion based on requirements and intended context of use	Measuring method
7.1 Specification of category	The user of this standard shall specify to which category a device belongs to.	Verify that a declaration has been made as to which category or categories (ISO 9241-410:2008, Annexes A to I) the device belongs.
7.1 Specification of category	The user of this standard shall specify to which category a device belongs to.	Verify that a declaration has been made as to which category or categories (ISO 9241-410:2008, Annexes A to I) the device belongs.
7.2.2 Anthropometric dimensions	The dimensioning of an input device and its parts shall be compatible with the relevant anthropometric dimensions of the part of the body for the intended user population to a degree that relevant design objectives can be met (intended level of effectiveness, intended level of efficiency). [Modified from ISO 9241-410]	Verify the dimensions of the device are appropriate for the intended user population. Verify the intended level of effectiveness, efficiency and satisfaction using the test methods described in Annexes B, C or D, as appropriate.
7.2.2 Appropriate-ness	If achieving the intended level of appropriateness requires enhancing by software or by additional use of another device other than delivered with the device under consideration the additional equipment shall be specified.	Specify if additional software or additional equipment is necessary.
7.2.3.6 Feedback	An input device shall provide effective feedback, i.e. the user is given immediately perceptible and understandable indication that the device is responding to the user's actuation.	Verify that the user: — can determine the current state of the device; — can determine the outcome of the latest action; — can determine any action that is required as a consequence of the previous action(s).
7.2.4.1 Adequate and reliable access	The design of the device shall give the user adequate and reliable access;	Verify that: — the input device provides adequate and reliable access can be used without undue biomechanical loading; — the input device can be used without inadvertent activation.
7.2.4.2 Device responsive-ness	The device shall be responsive, and its use shall not interfere with its functionality; [Modified from ISO 9241-410]	Verify that: — every operation performed with the input device generates the appropriate feedback; — the use of the input device does not necessarily interfere with its own function, e.g., a mouse that is entangled by its own tail.
7.2.4.1 Loss of control	The design shall prevent unintended loss of control during intended use, e.g. slipping by hand operated devices.	Verify that the input device can be used without unintended slipping when being held, pushed or activated.
7.2.4.3 Self-interference	An input device shall not interfere with its own use.	Verify that the user can access all functional elements of the input device without degrading the usability of the device.

Table 1 (continued)

Attribute in ISO 9241-410: 2008	Pass/Fail criterion based on requirements and intended context of use	Measuring method
7.2.4.3 Cable interference	Functional elements needed to transport data from the device to the system and vice versa (cables, infrared beams) shall not influence throughput and accuracy.	Verify that functional elements do not necessarily inhibit input actuation, thereby negatively influencing throughput and accuracy.
7.2.4.5 Readily usable design	The design of an input device shall enable the user to quickly and easily access it (e.g. grasp, position and manipulate) during intended use without adversely affecting performance.	Verify that the user can access the device without adversely affecting performance.
7.2.4.6 Readily usable controls	Controls of an input device shall be located and actuated quickly and easily without interfering with the overall use of the device.	Verify that accessing and activating an input device does not change the intended consequence, e.g. inadvertent movement of the hot spot resultant from pressing a button on a mouse.
7.2.5.2 Avoidance of extreme postures	An input device shall be operable without undue deviation from a neutral posture.	Verify that the design of the input device does not constrain the user's joints in positions at the extremes of the joint's range of motion while using the input device in the intended operation.
7.2.5.3 Avoidance of excessive effort	An input device designed for efficient use shall be operable without excessive effort.	Verify that the design of the input device does not force the user to make excessive exertions for the intended operation. Acceptable levels of effort may be documented by use of a survey similar to the example shown in Table C.1.
9 Description and operating instructions	The documentation of a product shall comprise the product description and the operating instructions.	Verify that the product documentation includes the product description and operating instructions.
9 Information for selection of appropriate device	The product description shall specify all relevant and usability related information for selecting the appropriate device.	Verify that the product documentation provides the information necessary for selecting the appropriate device.

5.2 Keyboards

Tables 2 to 12 give the requirements common to all keyboards, as well as those specific to a particular type of keyboard — for example, full-size or compact keyboards.

Table 2 — Requirements on the generic operability of keyboards

Attribute in ISO 9241-410: 2008	Pass/Fail criterion based on requirements and intended context of use	Conformance method
B.2.1.2.1 Obviousness of use	A keyboard shall either belong to class C1 for obviousness (known or visible without additional instructions and information) or the required level of instructions shall be specified.	Verify either: — that the keyboard is identified as C1; or — that the required level of instructions is provided in the documentation.

Table 3 — Requirements for functional properties of full-size keyboards

Attribute in ISO 9241-410: 2008	Pass/Fail criterion based on requirements and intended context of use	Measuring method
B.2.2.1.1 a) Keypop shape	The keytops of normal-size keys in the alphanumeric, cursor and numeric zones shall have either concave or flat strike surfaces.	Determine if the keytops in the alphanumeric, numeric and cursor zones are flat or concave (see Figure 7).
B.2.2.1.1 b) Strike surface	The strike surface of the keytops of alphanumeric keys shall be at least 110 mm ² in area, the width of the strike surface shall be between 12 mm and 15 mm.	Evaluate the area of the strike surface by measuring the width and depth of the top surface of the key and calculating the area (see Figure 8).
B.2.2.1.1 c) Displacement	The key displacement shall be between 1,5 mm and 6,0 mm.	The key displacement is measured by activating the key at its centre, in the direction of key motion, with an applied force of 1,5 N. The distance between height of the non-actuated key (before it is depressed) and the completely depressed key is the key displacement (see Figure 9). NOTE The force and displacement characteristics described herein do not apply to virtual keyboards, for example, those formed on a display or projected onto a surface.
B.2.1.2.2 Predictability of operation of keyboards	The class to which a keyboard belongs with regard to predictability shall be specified.	Verify either that: the keyboard is identified as C1 (i.e. capable of n-key roll-over where $n > 2$); or the restricted level of predictability C2 to C4 and is specified in the documentation. The following classes are categorized: — C1: n-key roll-over where $n > 2$; or equivalent — C2: two-key roll-over or equivalent; — C3: no roll-over, i.e. first activated key must be released before the subsequent key can be detected; — C4: delayed input required, i.e. after release of the first activated key, a defined waiting period is needed before a subsequent key can be detected.

Table 3 (continued)

Attribute in ISO 9241-410:2008	Pass/Fail criterion based on requirements and intended context of use	Measuring method
B.2.7.1 Documentation	<p>The documentation of a keyboard shall indicate whether:</p> <ul style="list-style-type: none"> — special training; — additional physical tools; — specific software is needed to achieve the intended level of usability (effectiveness, efficiency and satisfaction). 	<p>If special training, tools or software is necessary to provide the intended level of usability of the keyboard, verify that this information is provided in the keyboard documentation.</p> <p>NOTE Some examples of special training might include one-hand-keyboards, chording keyboards, special design keyboards. Normal training for typing on keyboards is not regarded as special training.</p>
B.2.2.1.1 d) Force	<p>The force at the character generation point or at the snap point should be between 0,5 N and 0,8 N and shall be between 0,25 N and 1,5 N.</p>	<p>Measure the key force and displacement relationship as illustrated in Figure 10.</p> <p>Determine the force (resistance) at the snap point (illustrated at 2 in Figure 10).</p> <p>NOTE The force and displacement characteristics described herein do not apply to virtual keyboards, for example, those formed on a display or projected onto a surface.</p>
B.2.2.1.1 e) Force/ displacement characteristics	<p>For displacement keyboards (see ISO 9241-410:2008, Figure B.3), the initial resistance (starting force or preload) shall be between 25 % and 75 % of the force at the character generation point (for ramp activation) or at the snap point (for snap action).</p>	<p>Measure the key force and displacement relationship as illustrated in Figure 10.</p> <p>Determine the force at which initial displacement of the key occurs (before the snap point, as illustrated at 6 in Figure 10).</p> <p>NOTE The force and displacement characteristics described herein do not apply to virtual keyboards, for example, those formed on a display or projected onto a surface.</p>
B.2.2.1.1 e) Force/ displacement characteristics	<p>The switch-make action in the snap action shall occur after the snap point but before the key force has returned to the snap point.</p>	<p>Verify (e.g. via a description of the key force and displacement as shown in Figure 10) that the switch make action occurs after the snap point but before the key force returns to the same level as at the snap point.</p>
B.2.2.1.1 f) Feedback	<p>Actuation of a key shall be accompanied by feedback.</p> <p>If the principle means (of feedback) is auditory, the auditory signal shall be perceptible in the use environment.</p>	<p>If auditory feedback is the principal means of feedback, verify that auditory feedback from the operation of the key(s) is perceptible from a background sound level of the intended use environment, generally 10 dB A-weighted above.</p>
B.2.2.1.1 f) Feedback	<p>Supplementary auditory feedback shall be suppressible (i.e. a volume control position that represents "off").</p>	<p>Verify that the auditory feedback from the key(s) can be suppressed or turned off.</p>
B.2.2.1.1 f) Feedback	<p>The feedback shall occur within 100 ms after the key activation.</p>	<p>Verify that auditory feedback occurs within 100 ms of key activation.</p>

Table 3 (continued)

Attribute in ISO 9241-410: 2008	Pass/Fail criterion based on requirements and intended context of use	Measuring method
B.2.2.1.1 g) Bounce	In order to prevent unintended multiple event signalling from a single key actuation, the keyboard shall be provided with either bounce-free switches or a means of ensuring that bounce will not cause unintended activation.	Take a random sample of five alphanumeric or numeric keys, and, with a mechanical device, actuate each key at a rate of 5 times per second using a force of 1,5 N for 60 s. Count the number of characters produced and determine if it is the same as the number of inputs (1 500 total, or 300 per key).
B.2.2.1.1 h) Key repeat function	Where a repeat function is provided, the fixed repeat rate shall be 10 activations per second to 20 activations per second after an initial delay between 500 ms and 750 ms after the key is actuated.	Actuate an alphanumeric key by holding it down for 15 s. Note the delay until the second character appears; this is the initial delay period. Determine the number of characters produced after the initial delay, and then divide this by the time that the key remains activated after the initial delay period to obtain the characters per second.
B.2.2.1.1 i) Key roll-over	C1 keyboards shall be equipped with n -key roll-over according to C1 (B.2.1.2.2). [Modified from ISO 9241-410] NOTE n -key roll-over is defined as follows: When a keyboard has n -key roll-over, if some number (n) of keys is pressed at the same time, then the input from each key is interpreted correctly. Keyboards where $n > 2$ are classed as C1. Touch-typing generally requires 3-key roll-over. For some limited keyboard uses, such as music, gaming and Braille input, n -key roll-over where $n > 3$ is utilized. In order to avoid confusion, it is recommended that a manufacturer of a C1 keyboard choose to specify the value of n for n -key roll-over when the value of $n > 3$.	Simultaneously press and hold three alphanumeric or numeric keys. If the keyboard is equipped with 3-key roll-over, the appropriate characters corresponding to the combination of the 3 keys will be produced. For C1 keyboards where $n > 3$, the appropriate characters corresponding to the combination of the n keys is produced when the n keys are pressed at the same time. NOTE n -key roll-over is defined as follows: When a keyboard has n -key roll-over, if some number (n) of keys is pressed at the same time, then the input from each key is interpreted correctly. Keyboards where $n > 2$ are classed as C1. Touch-typing generally requires 3-key roll-over. For some limited keyboard uses, such as music, gaming and Braille input, n -key roll-over where $n > 3$ is utilized. In order to avoid confusion, it is recommended that a manufacturer of a C1 keyboard choose to specify the value of n for n -key roll-over when the value of $n > 3$.
B.2.2.1.1 j) Geometric design of key legends	All legends on keys shall be legible from the design reference posture (see ISO 9241-5).	Measure the height of the characters in the key legends; the height of a capital letter such as "H" or "M" divided by the viewing distance shall be at least 0,006 (sine of 21' of arc).
B.2.2.1.1 j) Geometric design of key legends	The height of primary legends on an alphanumeric key shall not be $< 2,6$ mm. NOTE Assumes a viewing distance of 40 cm. [Modified from ISO 9241-410]	Character height is measured from the top line to the bottom edge of the bottom line of capitals "H" and "M" (see Figure 11).

Table 3 (continued)

Attribute in ISO 9241-410: 2008	Pass/Fail criterion based on requirements and intended context of use	Measuring method
B.2.2.1.1 j) Geometric design of key legends	The width of the capital letters (except I and W) shall be between 50 % and 100 % of the height.	Character width is measured from the left edge of the leftmost line to the right edge of the rightmost line without serifs. Divide the character width by the character height; acceptable values for the character width to height ratio are decimal fractions $\geq 0,5$ and $\leq 1,0$.
B.2.2.1.1 j) Luminance contrast	For primary legends on all keys, the luminance contrast between luminance level of the background and legends shall be a minimum of 3:1.	Use a microphotometer to measure the luminance level of the background and the legend. The ratio of the higher luminance level to the lower should be at least 3:1.
B.2.2.1.1 k) Graphical symbols	Where graphical symbols are used, these shall be in accordance with ISO/IEC 9995-7 and with ISO 7000 and IEC 60417 as applicable.	Verify that graphical symbols are designed according to ISO/IEC 9995-7, ISO 7000 and IEC 60417.
B.2.2.1.1 l) Placement of legends	The positioning of the legends shall be in accordance with ISO/IEC 9995-1.	Verify conformance with ISO/IEC 9995-1.
B.2.2.1.1 l) Overlays	If reference cards or overlays are used to provide legends, the overlays and reference cards shall have a matt finish. [Modified from ISO 9241-410]	Measure the gloss level of the reference cards or overlays using a glossmeter (60°). Acceptable results are 45 gloss units or less.
B.2.2.1.1 m) Durability of legends	The legends shall be legible throughout the intended life of the product.	Determine the total number of keystrokes expected during the life of the keyboard. Multiply the total number of keystrokes by the expected percentage of keystrokes that are expected to be "E", e.g. approximately 12 % in English. Verify that the legend remains legible after a number of actuations corresponding to the expected number of "E" keystrokes.
B.2.2.1.1 m) Durability of legends	The legends shall be robust and durable so that they are able to withstand normal wear and tear including regular cleaning. NOTE Currently the intended life of desktop keyboards is calculated for continuous typing on the type "E" over the workday during the full life-span of the product assuming the approximate occurrence of the character "E" in European languages.	Determine the total number of keystrokes expected during the life of the keyboard. Multiply the total number of keystrokes by the expected percentage of keystrokes that are expected to be "E", e.g. approximately 12 % in English. Verify that the legend remains legible after a number of actuations corresponding to the expected number of "E" keystrokes.

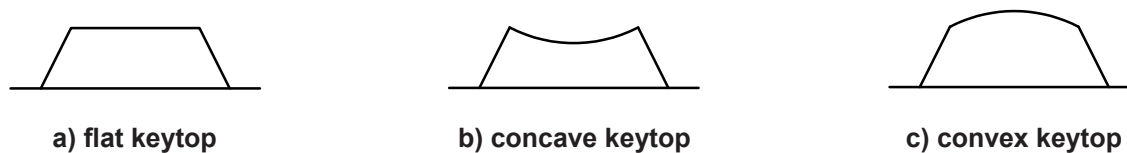
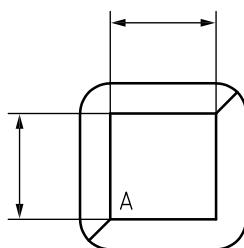
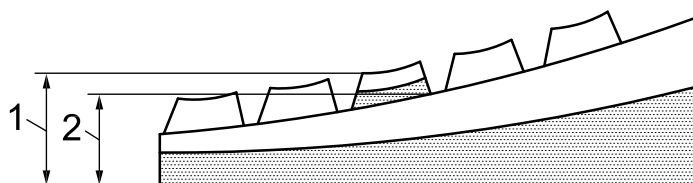

Figure 7 — Illustration of flat, concave and convex keytops



Key
A depth/width

Figure 8 — Measurement of keytop width and depth



Key
1 undepressed key
2 depressed key

Figure 9 — Measurement of key displacement

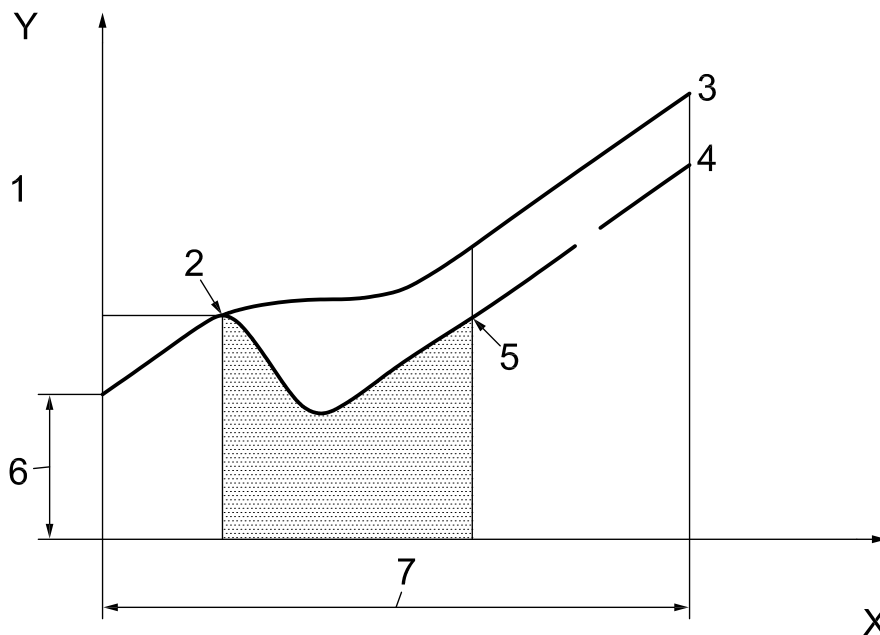

Key

- | | |
|--|---|
| 1 force at snap point between 0,5 N and 0,8 N (preferred) 0,25 N and 1,5 N (permitted) | 5 switch make point occurs – after the snap point – at force equal to or less than snap point |
| 2 snap point | 6 initial resistance between 25 % and 75 % of force at snap point |
| 3 ramp action | 7 full travel 2 mm–4 mm (preferred), 1,5 mm–6 mm (permitted) |
| 4 snap action | |

Figure 10 — Relationship between key displacement and key force (ISO 9241-410:2008, Figure B.3)

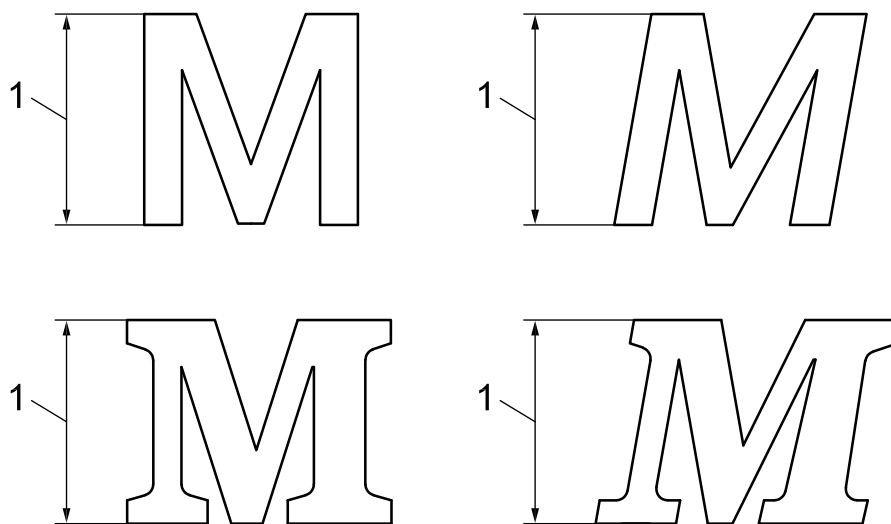

Key

- 1 character height

Figure 11 — Measurement of character height

Table 4 — Requirements for sections and zones of full-size keyboards

Attribute in ISO 9241-410: 2008	Pass/Fail criterion based on requirements and intended context of use	Measuring method
B.2.2.2.1 Sections and zones	A full-size desktop keyboard shall comprise all sections and zones as defined in ISO/IEC 9995-1. These are: — alphanumeric section; — numeric section; — editing section; — function section.	Verify that the keyboard includes at least the required sections (as defined in ISO/IEC 9995-1).
B.2.2.2.1 Differentiation of keyboard sections	The principle sections of a keyboard as defined in ISO/IEC 9995-1 shall be perceptually differentiated.	Verify that the required zones (as defined in ISO/IEC 9995-1) are perceptually differentiated by: — spatial separation by at least half a key pitch; or — otherwise visually differentiated.
B.2.3.1 a) Centre line spacing Layout	The layout of the keys shall conform to ISO/IEC 9995-1.	Verify that the layout conforms to ISO/IEC 9995-1. Keys in the alphanumeric and numeric zone are (19 mm ± 1 mm) centre-to-centre.
B.2.3.1 a) Vertical and horizontal separation of keys	The horizontal and vertical distances between two adjacent keys in the alphanumeric and the numeric zones measured centre-to-centre shall be (19 mm ± 1 mm).	Verify that the vertical and horizontal distance between any two keys in the alphanumeric or numeric zones is (19 mm ± 1 mm). Figure 12 illustrates the measurement of vertical and horizontal spacing of keys.
B.2.3.1 b) Keyboard height	The home row height of the keyboard shall not exceed 35 mm. [Modified from ISO 9241-410]	Select a key in the home row (C-row) of the keyboard. Without activating or depressing the key, measure, from the centre of the keytop, the height of the keytop above the supporting surface.
B.2.3.1 b) Height adjustment	If an adjustment mechanism is provided, there shall be at least one adjustment that allows it to comply with the height specification.	Verify that the height or slope adjustment feature of the keyboard allows at least one adjustment position that complies with the height specification.
B.2.3.1 d) Slope of keyboard	The slope of the unadjusted keyboard shall be between 0° and 15° positive.	Verify that the value of the slope of the keyboard is somewhere in the range between 0° and 15° positive (relative to horizontal). The slope of the keyboard is calculated from the difference in height between rows B and E (or B and D if the keyboard has no row E), measured at the top surface of the key and the horizontal distance between the points on the keys at which the height was measured. See Figure 13.
B.2.3.1 f) Keyboard surfaces	The visible surfaces of the keyboard shall be matt-finish. NOTE This is defined as not exceeding 45 gloss units at 60° or to a 60° reflectometer value < 20) [Modified from ISO 9241-410]	Verify that the surface does not exceed 45 gloss units at 60° or that it has a 60° reflectometer value < 20.

Table 4 (continued)

Attribute in ISO 9241-410: 2008	Pass/Fail criterion based on requirements and intended context of use	Measuring method
B.2.3.1 g) Numeric keypad	The ten digits zero to nine shall be allocated to keys in the numeric section in one of two ways: either in the form of the 1-2-3 (telephone) layout or the 7-8-9 (calculator) layout.	Verify that the numeric section layout matches either the telephone or calculator layout as illustrated in Figure 14.
B.2.3.1 h) Cursor control keys	Keys for the control of the cursor movement shall be provided.	Verify that cursor control keys are provided.

Table 5 — Requirements for the mechanical design of full-size keyboards

Attribute in ISO 9241-410: 2008	Pass/Fail criterion based on requirements and intended context of use	Measuring method
B.2.3.1 l) Slope adjustability and stability	Any keyboard slope adjustability shall not compromise the requirements for stability and placement. [Modified from ISO 9241-410]	Verify that: <ul style="list-style-type: none"> — for the range of slope adjustment, there is no motion of the keyboard on the supporting surface during use; — for the range of slope adjustment, the keyboard does not move vertically during use more than 0,25 mm (e.g. rock or tilt during use). <p>NOTE This does not apply to the displacement of the keys.</p>
B.2.3.1 l) Unintentional change of slope	Slope adjustments shall not change unintentionally. [Modified from ISO 9241-410]	Verify that the slope adjustment does not change unintentionally.
B.2.3.1 l) No tools necessary for slope adjustment	Tools shall not be required for slope adjustment purposes.	Verify that tools are not required for slope adjustment.

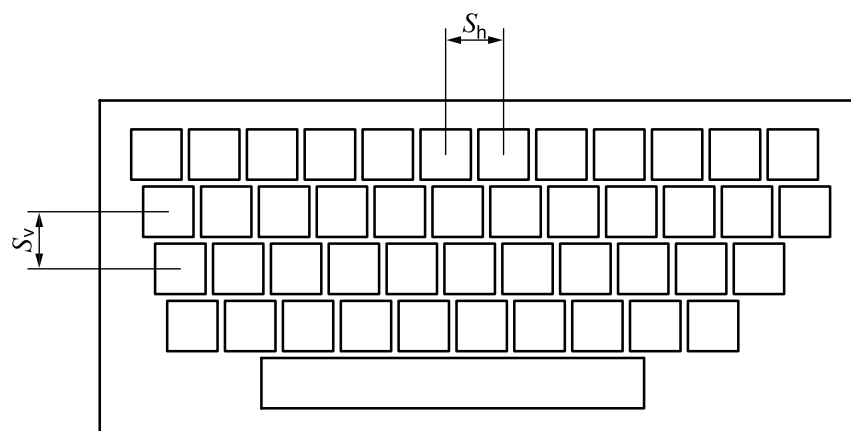

Key

S_v vertical distance between two adjacent keys

S_h horizontal distance between two adjacent keys

Figure 12 — Measurement of vertical and horizontal distance between two adjacent keys

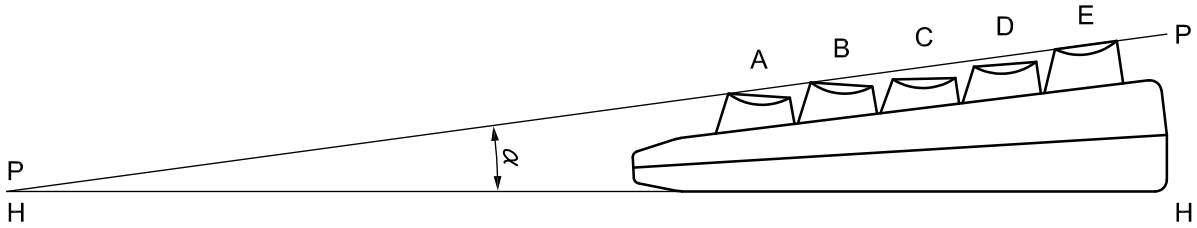

Key
 α keyboard slope
 P-P plane of the key top surface
 H-H plane of the horizontal surface

NOTE The keyboard slope α is measured across row A–E between the plane of the key top surfaces and the horizontal surface, using the notation of ISO/IEC 9995-1.

Figure 13 — Measurement of slope of keyboard

1	2	3
4	5	6
7	8	9
	0	

a) telephone (1-2-3)

7	8	9
4	5	6
1	2	3
	0	

b) calculator (7-8-9)

Figure 14 — Numeric keypad layout

Table 6 — Requirements for maintainability of full-size keyboards

Attribute in ISO 9241-410: 2008	Pass/Fail criterion based on requirements and intended context of use	Measuring method
B.2.5.1 Battery status indicator	For keyboards with independent battery power, there shall be an easily detectable indication of battery power status (e.g. indicator lamp, alarm sound or a mechanical indicator) provided either by a software-based or hardware-based device. [Modified from ISO 9241-410]	Verify that keyboards with independent battery power have either a hardware- or software-based battery power status indicator.
B.2.5.1 Functioning of device after low battery warning	The durability of the batteries and their electrical characteristics shall ensure that the user can complete the last actions after being warned or alerted by the indicator without high time pressure.	Verify that either a hardware- or software-based indicator can be provided. The device should continue to function for 5 min after the user is alerted by the indicator.

Table 7 — Requirements for documentation of full-size keyboards

Attribute in ISO 9241-410: 2008	Pass/Fail criterion based on requirements and intended context of use	Measuring method
B.2.7.2 Documentation of required software	The documentation shall indicate the need for specific software support if needed to achieve the intended level of effectiveness and efficiency.	If specific support software is required to achieve the desired level of effectiveness and efficiency of the keyboard, verify that the documentation indicates this.
B.2.9.1 Noise emitted from input devices	<p>The noise emission can be categorized in consideration of the intended application area and its typical ambient noise levels (see ISO 9241-6). The classes can be determined by the noise exposure data of ISO 11690-1:</p> <p>C1 suitable for meeting rooms or tasks involving concentration (35 dB to 45 dB A-weighted);</p> <p>C2 suitable for routine office work (45 dB to 55 dB A-weighted);</p> <p>C3 suitable for industrial workplaces (75 dB to 80 dB A-weighted).</p>	<p>Verify the reported noise emission. Measure the sound power level of the keyboard and state report the class:</p> <ul style="list-style-type: none"> — C1 suitable for meeting rooms or tasks involving concentration (< 45 dB A-weighted sound power level); — C2 suitable for routine office work (< 55 dB A-weighted sound power level); — C3 suitable for industrial workplaces (< 80 dB A-weighted sound power level).

Table 8 — Requirements for design of keys of compact keyboards

Attribute in ISO 9241-410: 2008	Pass/Fail criterion based on requirements and intended context of use	Measuring method
B.2.2.1.2 Durability of legends	<p>Legends shall be legible throughout the intended life of the product. The legends shall be robust and durable so that they are able to withstand normal wear and usage, including regular cleaning.</p> <p>[Modified from ISO 9241-410]</p> <p>If the device is designed to be used as an equivalent replacement for a full-size keyboard the intended life for the product is to be the same as for a full-size keyboard. For devices designed for integration into portable units (e.g. laptop computers) a less intensive use for keying may be assumed.</p> <p>NOTE Currently the intended life of desktop keyboards is calculated for continuous typing on "E" over the workday during the full life-span of the product, assuming the approximate occurrence of the character "E" in European languages.</p>	<p>Measure the luminance contrast after completion of the abrasion test. Perform the abrasion test according to IEC 68-2-70 with</p> <ul style="list-style-type: none"> — artificial sweat or comparable test fluid, — load severity of 1,5 N, number of activations according to the intended lifetime related to the context of use.

Table 8 (continued)

Attribute in ISO 9241-410: 2008	Pass/Fail criterion based on requirements and intended context of use	Measuring method
B.2.3.1 Contact with edges during use	Edges on a computer shall not have a radius < 2 mm; corners shall not have a radius < 3 mm. NOTE While not required, edges with a radius of 2 mm and corners with a radius of 3 mm are considered satisfactory.	Verify that the edges with which the user is likely to come into contact for prolonged periods of time do not cause discomfort or injury.

Table 9 — Requirements for sections and zones of compact keyboards

Attribute in ISO 9241-410: 2008	Pass/Fail criterion based on requirements and intended context of use	Measuring method
B.2.2.2.2 Sections and zones	A compact keyboard shall comprise the following sections and zones as defined in ISO/IEC 9995-1: — alphanumeric section; — editing section; — function section.	Verify that the keyboard includes at minimum the required sections (as defined in ISO/IEC 9995-1).

Table 10 — Requirements for mechanical design of compact keyboards

Attribute in ISO 9241-410: 2008	Pass/Fail criterion based on requirements and intended context of use	Measuring method
B.2.3.2 Cursor control keys	Keys for the control of cursor movement shall be provided.	Verify that cursor movement control keys are provided.
B.2.3.2 a) Centre line spacing:	The horizontal and vertical distances between two adjacent keys in the alphanumeric zone, and, if present, the numeric zones measured centre-to-centre shall be (19 mm ± 1 mm).	Verify that the vertical and horizontal distance between any two keys in the alphanumeric or numeric zones is (19 mm ± 1 mm). Figure 12 illustrates the measurement of vertical and horizontal spacing of keys.
B.2.3.2 b) Keyboard height	The home row height of the keyboard shall not exceed 35 mm.	Select a key in the home row (C-row) of the keyboard. Without activating or depressing the key, measure, from the centre of the keytop, the height of the keytop above the supporting surface.
B.2.3.2 c) Keyboard width	To achieve efficiency for the use of the keyboard, the overall size of a device shall be determined in consideration of the number of keys needed and their adequate grouping in sections and zones.	Verify that the overall size of a device is determined in consideration of the number of keys needed and their adequate grouping in sections and zones.
B.2.3.2 d) Keyboard slope	The slope of the unadjusted keyboard shall be between 0° and 15° positive. [Refers to B.2.3.1 d)]	Verify that the value of the slope of the keyboard is somewhere in the range between 0° and 15° positive (relative to horizontal). The slope of the keyboard is calculated from the difference in height between rows B and E (or B and D if the keyboard has no row E) (see ISO/IEC 9995-1:2009, Figure 3), measured at the top surface of the key and the horizontal distance between the points on the keys at which the height was measured. See Figure 13.

Table 10 (continued)

Attribute in ISO 9241-410: 2008	Pass/Fail criterion based on requirements and intended context of use	Measuring method
B.2.3.2 f) [refers to B.2.3.1 f)] Keyboard surface	The visible surfaces of the keyboard shall be matt-finish. NOTE This is defined as not exceeding 45 gloss units at 60° or to a 60° reflectometer value < 20). [Modified from ISO 9241-410]	Verify that the surface does not exceed 45 gloss units at 60° or that it has a 60° reflectometer value < 20.
B.2.3.2 k) [refers to B.2.3.1 l)] Stability	Any keyboard slope adjustability shall not compromise the requirements for stability and placement. [Modified from ISO 9241-410]	Verify that: — for the range of slope adjustment, there is no motion of the keyboard on the supporting surface during use; — for the range of slope adjustment, the keyboard does not move vertically during use more than 0,25 mm (e.g. rock or tilt during use). NOTE This does not apply to the displacement of the keys.
B.2.3.2 k) [refers to B.2.3.1 l)] Unintentional changes in slope	Slope adjustments shall not change unintentionally.	Verify that the slope adjustment does not change unintentionally.
B.2.3.2 k) [refers to B.2.3.1 l)] No tools necessary to adjust slope	Tools shall not be required for slope adjustment purposes.	Verify that tools are not required for slope adjustment.

Table 11 — Requirements for maintainability of compact keyboards

Attribute in ISO 9241-410: 2008	Pass/Fail criterion based on requirements and intended context of use	Measuring method
B.2.5.2 Battery status indicator	For keyboards with independent battery power, there shall be an easily detectable indication of battery power status (e.g. indicator lamp, alarm sound or a mechanical indicator). [Modified from ISO 9241-410]	Verify that keyboards with independent battery power have a battery power status indicator.
B.2.5.2 Functioning of device after low battery warning	The durability of the batteries and their electrical characteristics shall ensure that the user can complete the last actions after being warned without high time pressure. NOTE e.g. continues to function for 5 min.	Verify that the battery power indicator provides an alert at least 5 min of normal operation prior to shutting down.

Table 12 — Requirements for documentation of compact keyboards

Attribute in ISO 9241-410: 2008	Pass/Fail criterion based on requirements and intended context of use	Measuring method
B.2.7.3 Documentation of required software	The documentation shall indicate the need for specific software support if needed to achieve the intended level of effectiveness and efficiency	If specific support software is required to achieve the desired level of effectiveness and efficiency of the keyboard, verify that the documentation indicates this.
B.2.9.1 Noise emissions from input device	The noise emission can be categorized in consideration of the intended application area and its typical ambient noise levels (see ISO 9241-6). The classes can be determined by the noise exposure data of ISO 11690-1: C1 suitable for meeting rooms or tasks involving concentration (35 dB to 45 dB A-weighted); C2 suitable for routine office work (45 dB to 55 dB A-weighted); C3 suitable for industrial workplaces (75 dB to 80 dB A-weighted).	Measure the sound pressure level at operator position of the keyboard and state the class: — C1 suitable for meeting rooms or tasks involving concentration (< 45 dB A-weighted sound pressure level at operator position); — C2 suitable for routine office work (< 55 dB A-weighted sound pressure level at operator position); — C3 suitable for industrial workplaces (< 80 dB A-weighted sound pressure level at operator position).

5.3 Mice

Table 13 gives the design requirements for mice.

Table 13 — Mouse design requirements

Attribute in ISO 9241-410: 2008	Pass/Fail criterion based on requirements and intended context of use	Measuring method
C.2.1.2 Documentation of necessary training or necessary instructions	A mouse whose obviousness of operation is classed as C3 or C4 shall include the relevant information in its documentation; e.g. instructions or training. [Modified from ISO 9241-410]	Verify that the appropriate information is present in the documentation. NOTE The obviousness of the mouse operation can be realized in four classes: — C1 known or visible without additional instructions and information; — C2 detectable by the user by trial and error; — C3 learnable by simple instructions; — C4 learnable by special training.
C.2.2.4.6 Button displacement	The maximum button displacement on a mouse shall be ≤ 6 mm.	Verify that the maximum button displacement is ≤ 6 mm.
C.2.1.5.1 Controllability	The design of the mouse shall enable the user to sense the orientation of the device without visual access.	Verify that the orientation of the mouse may be determined without visual access for example by tactile marking or form.

Table 13 (continued)

Attribute in ISO 9241-410: 2008	Pass/Fail criterion based on requirements and intended context of use	Measuring method
C.2.1.5.3 Stability of pointer focus	The design of the device shall ensure that actuation of any button or button combination will not move the pointer focus.	Verify that actuation of any button does not move the focus of the pointer.
C.2.2.1 Anchoring	It shall be possible to anchor support for some part of the fingers, hand, wrist, or arm on either the input device or the work surface to create a stable relationship between the hand and the point of action.	Verify that some part of the fingers, hand, wrist or arm can be supported on either the input device or the work surface.
C.2.2.2 Task precision	<p>The task precision required for a mouse can be categorized into the following classes:</p> <ul style="list-style-type: none"> — C1 high: $I_D > 6$; — C2 medium: $4 < I_D \leq 6$; — C3 low: $3 < I_D \leq 4$; — C4 very low: $I_D \leq 3$. <p>The method by which the task precision level was determined shall be indicated (pointing test, dragging test or tracing test); the mouse manufacturer shall indicate how the precision level was determined (pointing test, dragging test or tracing test).</p>	<p>I_D is defined in 3.6.</p> <p>Any method of measuring task precision may be used. Some examples are provided in Annex B:</p> <ul style="list-style-type: none"> — B.6.2.1 “One direction tapping test”; — B.6.2.2 “Multi-direction tapping test”; — B.6.3 “Dragging test”; — B.6.5 “Tracing test”.
C.2.2.2 Determination of task precision	<p>The task precision of a mouse used with a graphical user interface (GUI)-based operating system shall be determined under the following conditions:</p> <ul style="list-style-type: none"> — full-size keyboard (over-all length ≥ 420 mm) located with alphanumeric zone centred in front of the user; — mouse positioned as closely as possible to the shoulder width of 5th percentile female of the intended user population. <p>[Modified from ISO 9241-410]</p>	<p>Any method of measuring task precision may be used. Some examples are provided in Annex B:</p> <ul style="list-style-type: none"> — B.6.2.1 “One direction tapping test”; — B.6.2.2 “Multi-direction tapping test”; — B.6.3 “Dragging test”; — B.6.5 “Tracing test”.
C.2.2.4.8 Button lock	<p>The mouse shall be so designed that a hardware or software lock can be provided for buttons which need to be continuously depressed for the duration of a task primitive such as dragging, tracing, or free-hand input.</p> <p>[Modified from ISO 9241-410]</p>	Verify that the mouse is designed so that a hardware or software lock can be provided for buttons that need to be continuously depressed.

Table 13 (continued)

Attribute in ISO 9241-410: 2008	Pass/Fail criterion based on requirements and intended context of use	Measuring method
C.2.2.6 Mouse resolution	The resolution of a mouse shall be independent of both the position of the device relative to the work surface and position of pointer on the display.	Verify that the resolution is independent of the input device position relative to the work surface and the position of the cursor on the display.
C.2.5 Maintainability	The design of the mouse shall allow the user to gain access to maintainable parts (e.g. the mouse-ball housing of the motion sensing device) and the surface of the mouse for cleaning without the use of tools. [Modified from ISO 9241-410]	Verify that tools are not required.
C.2.6 Contact with edges during use	Edges on a computer mouse shall not cause discomfort or injury. NOTE A radius of at least 2 mm on edges with which the user comes into contact and a radius of at least 3 mm on corners with which the user comes into contact will satisfy this requirement. [Modified from ISO 9241-410]	Verify that the edges with which the user is likely to come into contact for prolonged periods of time do not cause discomfort or injury.
C.2.7 Documentation of special setup procedures	If no dedicated software, e.g. a driver, is provided with the mouse, the documentation shall specify how the mouse is to be set up and to be operated in order to achieve the intended level of effectiveness and efficiency. [Modified from ISO 9241-410]	In that absence of dedicated software, verify that the recommended set up and operation procedures are described for the mouse.
C.3 Documentation	The user information shall include the following: — optimum location of the mouse for best effectiveness, efficiency and postural comfort; — best location of the device for concurrent use with a keyboard; — adjustment of gain for limited space for the operation. [Modified from ISO 9241-410]	Verify that the manufacturer provides information regarding placement of the input device and for adjusting the gain of the device.
C.3 Documentation	If a mouse requires specific surface characteristics for optimum effectiveness and efficiency, the manufacturer shall provide that information.	Verify that the relevant information is provided.

5.4 Pucks

Table 14 gives the design requirements for pucks.

Table 14 — Design requirements for pucks

Attribute in ISO 9241-410: 2008	Pass/Fail criterion based on requirements and intended context of use	Measuring method
D.2.1.2 Operability of the puck	A puck whose obviousness of operation is classed as C3 or C4 shall include the relevant information in its documentation, e.g. instructions or training. [Modified from ISO 9241-410]	Verify that the appropriate information is present in the documentation. The obviousness of the puck operation can be realized in four classes: — C1 known or visible without additional instructions and information; — C2 detectable by the user by trial and error; — C3 learnable by simple instructions; — C4 learnable by special training.
D.2.2.3.6 Button displacement	The maximum button displacement on a puck shall be ≤ 6 mm.	Verify that the maximum button displacement is ≤ 6 mm.
D.2.1.5.3 Stability of focus	The design of the device shall ensure that actuation of any button or combination of buttons will not move the focus of the pointer.	Verify that actuation of any button does not move the focus of the pointer.
D.2.2.1 Anchoring	It shall be possible to anchor some part of the fingers, hand, wrist, or arm on either the input device or the work surface to create a stable relationship between the hand and the point of action.	Verify that some part of the fingers, hand, wrist or arm can be anchored on either the input device or the work surface.
D.2.2.2 Task precision	The task precision required for a puck can be categorized into the following classes: — C1 high: $I_D > 6$; — C2 medium: $4 < I_D \leq 6$; — C3 low: $3 < I_D \leq 4$; — C4 very low: $I_D \leq 3$. The method by which the level of task precision has been determined shall be indicated (pointing test, dragging test or tracing test). The manufacturer of a puck shall indicate how the level of task precision was determined (pointing test, dragging test or tracing test).	I_D is defined in 3.6. Any method of measuring task precision may be used. Some examples are provided in Annex B: — B.6.2.1 “One direction tapping test”; — B.6.2.2 “Multi-direction tapping test”; — B.6.3 “Dragging test”; — B.6.5 “Tracing test”.

Table 14 (continued)

Attribute in ISO 9241-410: 2008	Pass/Fail criterion based on requirements and intended context of use	Measuring method
D.2.2.2 Procedure for determining task precision	<p>A puck used with a graphical user interface (GUI)-based operating system shall be determined under the following conditions:</p> <ul style="list-style-type: none"> — full-size keyboard (over-all length \geq 420 mm) located with alphanumeric zone centred in front of the user; — puck positioned as closely as possible to the shoulder width of 5th percentile female of the intended user population. <p>[Modified from ISO 9241-410]</p>	<p>Any method of measuring task precision may be used. Some examples are provided in Annex B:</p> <ul style="list-style-type: none"> — B.6.2.1 “One direction tapping test”; — B.6.2.2 “Multi-direction tapping test”; — B.6.3 “Dragging test”; — B.6.5 “Tracing test”.
D.2.2.3.8 Button lock	<p>The puck shall be so designed that a hardware or software lock can be provided for buttons which need to be continuously depressed for the duration of a task primitive such as dragging, tracing, or free-hand input.</p>	<p>Verify that the puck is designed so that a hardware or software lock can be provided for buttons that need to be continuously depressed.</p>
D.2.2.5 Resolution	<p>The resolution of a puck shall be independent of both the position of the device relative to the work surface and the position of the pointer on the display.</p>	<p>Verify that the resolution is independent of the input device position relative to the work surface and the position of the cursor on the display.</p>
D.2.5 Maintainability	<p>If cleaning requires any precautionary measures, they shall be described in the documentation.</p>	<p>Verify that tools any precautions regarding cleaning are described.</p>
	<p>Battery durability, if batteries are required for operation of the puck, shall warn the user when they are nearly exhausted so as to ensure that the user can complete the last action after the warning without high time pressure.</p> <p>[Modified from ISO 9241-410]</p>	<p>For battery powered pucks only:</p> <p>Verify that a warning is provided about 5 min of normal operation before the battery is exhausted.</p>

Table 14 (continued)

Attribute in ISO 9241-410: 2008	Pass/Fail criterion based on requirements and intended context of use	Measuring method
D.2.6 Contact with edges	<p>Edges on a computer puck shall not cause discomfort or injury.</p> <p>NOTE A radius of at least 2 mm on edges with which the user comes into contact and a radius of at least 3 mm on corners with which the user comes into contact will satisfy this requirement.</p> <p>[Modified from ISO 9241-410]</p>	Verify that the edges with which the user is likely to come into contact for prolonged periods of time do not cause discomfort or injury.
D.2.7 Documentation of special setup procedures	If no dedicated software, e.g. a driver, is provided with the input device, the documentation shall specify how the device is to be set up and to be operated in order to achieve the intended level of effectiveness and efficiency.	In that absence of dedicated software, verify that the recommended set up and operation procedures are described for the input device.
D.3 Documentation	<p>The user information shall include the following. The manufacturer of a puck shall provide the following information:</p> <ul style="list-style-type: none"> — optimum location of the puck for best effectiveness, efficiency and postural comfort; <p>[Modified from ISO 9241-410]</p> <ul style="list-style-type: none"> — best location of the device for concurrent use with a keyboard; — adjustment of gain for limited space for the operation. 	Verify that the manufacturer provides information regarding placement of the input device and for adjusting the gain of the device.
D.3 Documentation	If a puck requires specific surface characteristics for optimum effectiveness and efficiency, the relevant requirement shall be specified in the documentation. The manufacturer shall provide that information.	Verify that the relevant information is provided.

5.5 Joysticks

Table 15 gives the design requirements for joysticks.

NOTE A joystick is a device that provides input in up to three dimensions.

Table 15 — Design requirements for joysticks

Attribute in ISO 9241-410: 2008	Pass/Fail criterion based on requirements and intended context of use	Measuring method
E.2.1.2 Operability of the joystick	<p>A joystick whose obviousness of operation is classed as C3 or C4 shall include the relevant information in its documentation; e.g. instructions or training.</p> <p>The obviousness of the joystick operation can be realized in four classes:</p> <ul style="list-style-type: none"> — C1 known or visible without additional instructions and information; — C2 detectable by the user by trial and error; — C3 learnable by simple instructions; — C4 learnable by special training. <p>[Modified from ISO 9241-410]</p>	Verify that the appropriate information is present in the documentation.
E.2.1.5.3 Stability of focus	The design of the device shall ensure that actuation of any button or combination of buttons will not move the focus of the pointer.	Verify that actuation of any button does not move the focus of the pointer.
E.2.2.1 Anchoring	It shall be possible to anchor some part of the fingers, hand, wrist, or arm on either the input device or the work surface to create a stable relationship between the hand and the point of action.	Verify that some part of the fingers, hand, wrist or arm can be anchored on either the input device or the work surface.

Table 15 (continued)

Attribute in ISO 9241-410: 2008	Pass/Fail criterion based on requirements and intended context of use	Measuring method
E.2.2.2 Task precision	<p>The task precision required for a joystick can be categorized into the following classes:</p> <ul style="list-style-type: none"> — C1 high: $I_D > 6$; — C2 medium: $4 < I_D \leq 6$; — C3 low: $3 < I_D \leq 4$; — C4 very low: $I_D \leq 3$. <p>The method by which the level of task precision has been determined shall be indicated (pointing test, dragging test or tracing test).</p>	<p>I_D is defined in 3.6.</p> <p>Any method of measuring task precision may be used. Some examples are provided in Annex B:</p> <ul style="list-style-type: none"> — B.6.2.1 “One direction tapping test”; — B.6.2.2 “Multi-direction tapping test”; — B.6.3 “Dragging test”.
E.2.2.2 Procedure for demonstrating task precision	<p>A joystick used with a graphical user interface (GUI)-based operating system shall be determined under the following conditions:</p> <ul style="list-style-type: none"> — full-size keyboard (overall length ≥ 420 mm) located with alphanumeric zone centred in front of the user; — joystick positioned as closely as possible to the shoulder width of 5th percentile female of the intended user population. <p>[Modified from ISO 9241-410]</p>	<p>Any method of measuring task precision may be used. Some examples are provided in Annex B:</p> <ul style="list-style-type: none"> — B.6.2.1 “One direction tapping test”; — B.6.2.2 “Multi-direction tapping test”; — B.6.3 “Dragging test”; — B.6.5 “Tracing test”.
E.2.2.3.8 Button lock	<p>The joystick shall be so designed that a hardware or software lock can be provided for buttons which need to be continuously depressed for the duration of a task primitive such as dragging, tracing, or free-hand input.</p>	<p>Verify that the joystick provides a suitable hardware or software lock.</p>
E.2.2.5 Resolution	<p>The resolution of a joystick shall be independent of both the position of the device relative to the work surface and the position of the pointer on the display.</p>	<p>Verify that the resolution is independent of the input device position relative to the work surface and the position of the pointer on the display.</p>

Table 15 (continued)

Attribute in ISO 9241-410: 2008	Pass/Fail criterion based on requirements and intended context of use	Measuring method
E.2.3.1 Stability	<p>The base of the device shall not be moved unintentionally during intended use.</p> <p>NOTE The base of a joystick may require greater resistance to movement than that of a keyboard, as the type of intended action involves horizontal forces in addition to vertical forces.</p>	Verify that the input device does not unintentionally move during use.
E.2.6 Contact with edges during use	<p>Edges on a computer joystick shall not cause discomfort or injury.</p> <p>NOTE A radius of at least 2 mm on edges with which the user comes into contact and a radius of at least 3 mm on corners with which the user comes into contact will satisfy this requirement.</p> <p>[Modified from ISO 9241-410]</p>	Verify that the edges with which the user is likely to come into contact for prolonged periods of time do not cause discomfort or injury.
E.2.7 Documentation of setup requirements	If no dedicated software, e.g. a driver, is provided with the input device, the documentation shall specify how the device is to be set up and to be operated in order to achieve the intended level of effectiveness and efficiency.	In the absence of dedicated software, verify that the recommended set up and operation procedures are described for the input device.
E.3. Documentation	<p>The user information shall include the following:</p> <ul style="list-style-type: none"> — optimum location of the joystick for best effectiveness, efficiency and postural comfort; — best location of the device for concurrent use with a keyboard; — adjustment of gain for limited space for the operation. <p>[Modified from ISO 9241-410]</p>	Verify that the manufacturer provides information regarding placement of the input device and for adjusting the gain of the device.

5.6 Trackballs

Table 16 gives the design requirement for trackballs.

Table 16 — Design requirements for trackballs

Attribute in ISO 9241-410: 2008	Pass/Fail criterion based on requirements and intended context of use	Measuring method
<p>F.2.1.2</p> <p>Operability of the trackball</p>	<p>A trackball whose obviousness of operation is classed as C3 or C4 shall include the relevant information in its documentation, e.g. instructions or training.</p> <p>The obviousness of the trackball operation can be realized in four classes:</p> <ul style="list-style-type: none"> — C1 known or visible without additional instructions and information; — C2 detectable by the user by trial and error; — C3 learnable by simple instructions; — C4 learnable by special training. <p>[Modified from ISO 9241-410]</p>	<p>Verify that the appropriate information is present in the documentation.</p>
<p>F.2.1.5</p> <p>Stability of focus during operation</p>	<p>The design of the device shall ensure that actuation of any button or combination of buttons will not move the focus of the pointer.</p>	<p>Verify that actuation of any button does not move the focus of the pointer.</p>
<p>F.2.2.1</p> <p>Anchoring</p>	<p>It shall be possible to anchor some part of the fingers, hand, wrist, or arm on either the input device or the work surface to create a stable relationship between the hand and the point of action.</p>	<p>Verify that some part of the fingers, hand, wrist or arm can be anchored on either the input device or the work surface.</p>

Table 16 (continued)

Attribute in ISO 9241-410: 2008	Pass/Fail criterion based on requirements and intended context of use	Measuring method
F.2.2.2 Task precision	<p>The task precision required for a trackball can be categorized into the following classes:</p> <ul style="list-style-type: none"> — C1 high: $I_D > 6$; — C2 medium: $4 < I_D \leq 6$; — C3 low: $3 < I_D \leq 4$; — C4 very low: $I_D \leq 3$. <p>The method by which the level of task precision has been determined shall be indicated (pointing test, dragging test or tracing test).</p>	<p>I_D is given defined in 3.6.</p> <p>Any method of measuring task precision may be used. Some examples are provided in Annex B:</p> <ul style="list-style-type: none"> — B.6.2.1 “One direction tapping test”; — B.6.2.2 “Multi-direction tapping test”; — B.6.3 “Dragging test”; — B.6.5 “Tracing test”.
F.2.2.2 Demonstration of task precision	<p>A trackball used with a Graphical User Interface (GUI)-based operating system shall be determined under the following conditions:</p> <ul style="list-style-type: none"> — full-size keyboard (overall length ≥ 420 mm) located with alphanumeric zone centred in front of the user; — trackball positioned as closely as possible to the shoulder width of 5th percentile female of the intended user population. <p>[Modified from ISO 9241-410]</p>	<p>Any method of measuring task precision may be used. Some examples are provided in Annex B.</p> <ul style="list-style-type: none"> — B.6.2.1 “One direction tapping test”; — B.6.2.2 “Multi-direction tapping test”; — B.6.3 “Dragging test”; — B.6.5 “Tracing test”.
F.2.2.3.8 Button lock	<p>The trackball shall be so designed that a hardware or software lock can be provided for buttons which need to be continuously depressed for the duration of a task primitive such as dragging, tracing, or free-hand input.</p>	<p>Verify that the trackball is designed so that a hardware or software lock can be provided for buttons that need to be continuously depressed.</p>
F.2.2.5 Resolution	<p>The resolution of a trackball shall be independent of both the position of the device relative to the work surface and the position of the pointer on the display.</p>	<p>Verify that the resolution is independent of the input device position relative to the work surface and the position of the pointer on the display.</p>

Table 16 (continued)

Attribute in ISO 9241-410: 2008	Pass/Fail criterion based on requirements and intended context of use	Measuring method
F.2.3.2 Stability	<p>The base of the device shall not move unintentionally during intended use.</p> <p>NOTE The base of a trackball may require greater resistance to movement than that of a keyboard, as the type of intended action involves horizontal forces in addition to vertical forces.</p>	Verify that the input device does not move unintentionally during use.
F.2.3.5 Non-interference of button operation	The buttons shall be located such that their use does not interfere with the use of the device.	Verify that operating the buttons does not interfere with the use of the device.
F.2.5 Cleaning	The ball shall be easily removable for cleaning.	When identified by the manufacturer that the ball of a trackball is removable for cleaning, verify that it can be removed.
F.3. Documentation	<p>The user information shall include the following:</p> <ul style="list-style-type: none"> — optimum location of the trackball for best effectiveness, efficiency and postural comfort; — best location of the device for concurrent use with a keyboard; — adjustment of gain for limited space for the operation. <p>[Modified from ISO 9241-410]</p>	Verify that the manufacturer provides information regarding placement of the input device and for adjusting the gain of the device.

5.7 Touchpads

Table 17 gives the design requirements for touchpads.

Table 17 — Design requirements for touchpads

Attribute in ISO 9241-410: 2008	Pass/Fail criterion based on requirements and intended context of use	Measuring method
<p>G.2.1.2</p> <p>Operability of the touchpad</p>	<p>A touchpad whose obviousness of operation is classed as C3 or C4 shall include the relevant information in its documentation, e.g. instructions or training.</p> <p>The obviousness of the touchpad operation can be realized in four classes:</p> <ul style="list-style-type: none"> — C1 known or visible without additional instructions and information; — C2 detectable by the user by trial and error; — C3 learnable by simple instructions; — C4 learnable by special training. 	<p>Verify that the appropriate information is present in the documentation.</p>
<p>G.2.1.5.3</p> <p>Stability of focus</p>	<p>The design of the device shall ensure that actuation of any button or combination of buttons will not move the focus of the pointer.</p>	<p>Verify that actuation of any button does not move the focus of the pointer.</p>
<p>G.2.2.1</p> <p>Anchoring</p>	<p>It shall be possible to anchor some part of the fingers, hand, wrist, or arm on either the input device or the work surface to create a stable relationship between the hand and the point of action.</p> <p>[Modified from ISO 9241-410]</p>	<p>Verify that some part of the fingers, hand, wrist or arm can be anchored on either the input device or the work surface.</p>
<p>G.2.2.2</p> <p>Task precision</p>	<p>The task precision required for a touchpad can be categorized into the following classes:</p> <ul style="list-style-type: none"> — C1 high: $I_D > 6$; — C2 medium: $4 < I_D \leq 6$; — C3 low: $3 < I_D \leq 4$; — C4 very low: $I_D \leq 3$. <p>The method by which the level of task precision has been determined shall be indicated (pointing test, dragging test or tracing test).</p>	<p>I_D is defined in 3.6.</p> <p>Any method of measuring task precision may be used. Some examples are provided in Annex B:</p> <ul style="list-style-type: none"> — B.6.2.1 “One direction tapping test”; — B.6.2.2 “Multi-direction tapping test”; — B.6.3 “Dragging test”; — B.6.5 “Tracing test”.

Table 17 (continued)

Attribute in ISO 9241-410: 2008	Pass/Fail criterion based on requirements and intended context of use	Measuring method
G.2.2.2 Task precision	<p>The task precision required for a touchpad can be categorized into the following classes:</p> <ul style="list-style-type: none"> — C1 high: $I_D > 6$; — C2 medium: $4 < I_D \leq 6$; — C3 low: $3 < I_D \leq 4$; — C4 very low: $I_D \leq 3$. <p>The method by which the level of task precision has been determined shall be indicated (i.e. pointing test, dragging test or tracing test).</p>	<p>I_D is defined in 3.6.</p> <p>Any method of measuring task precision may be used. Some examples are provided in Annex B:</p> <ul style="list-style-type: none"> — B.6.2.1 “One direction tapping test”; — B.6.2.2 “Multi-direction tapping test”; — B.6.3 “Dragging test”; — B.6.5 “Tracing test”.
G.2.2.2 Demonstration of task precision	<p>A touchpad used with a graphical user interface (GUI)-based operating system shall be determined under the following conditions:</p> <ul style="list-style-type: none"> — full-size keyboard (overall length ≥ 420 mm) located with alphanumeric zone centred in front of the user; — touchpad positioned as closely as possible to the shoulder width of 5th percentile female of the intended user population. <p>[Modified from ISO 9241-410]</p>	<p>Any method of measuring task precision may be used. Some examples are provided in Annex B:</p> <ul style="list-style-type: none"> — B.6.2.1 “One direction tapping test”; — B.6.2.2 “Multi-direction tapping test”; — B.6.3 “Dragging test”; — B.6.5 “Tracing test”.
G.2.2.3.8 Button lock	<p>The touchpad shall be so designed that a hardware or software lock can be provided for buttons which need to be continuously depressed for the duration of a task primitive such as dragging, tracing, or free-hand input.</p>	<p>Verify that the touchpad is designed so that a hardware or software lock can be provided for buttons that need to be continuously depressed.</p>
G.2.2.5 Resolution	<p>The resolution of a touchpad shall be independent of both the position of the device relative to the work surface and the position of the pointer on the display.</p>	<p>Verify that the resolution is independent of the input device position relative to the work surface and the position of the pointer on the display.</p>

Table 17 (continued)

Attribute in ISO 9241-410: 2008	Pass/Fail criterion based on requirements and intended context of use	Measuring method
G.2.3.5 Non-interference of buttons with operation	The buttons shall be located such that their use does not interfere with the operation of the touchpad.	Verify that the buttons can be used without interfering with the operation of the touchpad.
G.2.6 Contact with edges during use	Edges on a computer touchpad shall not cause discomfort or injury. NOTE A radius of at least 2 mm on edges with which the user comes into contact and a radius of at least 3 mm on corners with which the user comes into contact will satisfy this requirement. [Modified from ISO 9241-410]	Verify that the edges with which the user is likely to come into contact for prolonged periods of time do not cause discomfort or injury.
G.2.7 Documentation of special setup requirements	If no dedicated software, e.g. a driver, is provided with the touchpad, the documentation shall specify how the touchpad is to be set up and to be operated in order to achieve the intended level of effectiveness and efficiency.	In that absence of dedicated software, verify that the recommended set up and operation procedures are described for the touchpad.
G.3. Documentation	The user information shall include the following: — optimum location of the touchpad for best effectiveness, efficiency and postural comfort; — best location of the device for concurrent use with a keyboard; — features of the hardware/software that may improve postural comfort or reduce biomechanical load. NOTE The optimum location for the touchpad can be irrelevant when the location is fixed, e.g. incorporated into the keyboard.	Verify that the information is provided.

5.8 Tablets and overlays

Table 18 gives the design requirements for tablets and overlays.

Table 18 — Design requirements for tablets and overlays

Attribute in ISO 9241-410: 2008	Pass/Fail criterion based on requirements and intended context of use	Measuring method
<p>H.2.1.2 Operability of the tablet</p>	<p>A tablet whose obviousness of operation is classed as C3 or C4 shall include the relevant information in its documentation; e.g. instructions or training.</p> <p>The obviousness of the tablet operation can be realized in four classes:</p> <ul style="list-style-type: none"> — C1 known or visible without additional instructions and information; — C2 detectable by the user by trial and error; — C3 learnable by simple instructions; — C4 learnable by special training. <p>[Modified from ISO 9241-410]</p>	<p>Verify that the appropriate information is present in the documentation.</p>
<p>H.2.1.5.3 Stability of focus</p>	<p>The design of the device shall ensure that actuation of any button or combination of buttons will not move the focus of the pointer.</p>	<p>Verify that actuation of any button does not move the focus of the pointer.</p>
<p>H.2.2.2 Task precision</p>	<p>The task precision required for a tablet can be categorized into the following classes:</p> <ul style="list-style-type: none"> — C1 high: $I_D > 6$; — C2 medium: $4 < I_D \leq 6$; — C3 low: $3 < I_D \leq 4$; — C4 very low: $I_D \leq 3$. <p>The method by which the level of task precision has been determined shall be indicated (pointing test, dragging test or tracing test).</p>	<p>I_D is defined in 3.6.</p> <p>Any method of measuring task precision may be used. Some examples are provided in Annex B:</p> <ul style="list-style-type: none"> — B.6.2.1 “One direction tapping test”; — B.6.2.2 “Multi-direction tapping test”; — B.6.3 “Dragging test”; — B.6.5 “Tracing test”.

Table 18 (continued)

Attribute in ISO 9241-410: 2008	Pass/Fail criterion based on requirements and intended context of use	Measuring method
H.2.2.2 Demonstration of task precision	<p>A tablet used with a graphical user interface (GUI)-based operating system shall be determined under the following conditions:</p> <ul style="list-style-type: none"> — full-size keyboard (overall length ≥ 420 mm) located with alphanumeric zone centred in front of the user; — tablet positioned as closely as possible to the shoulder width of 5th percentile female of the intended user population. <p>[Modified from ISO 9241-410]</p>	<p>Any method of measuring task precision may be used. Some examples are provided in Annex B:</p> <ul style="list-style-type: none"> — B.6.2.1 “One direction tapping test”; — B.6.2.2 “Multi-direction tapping test”; — B.6.3 “Dragging test”; — B.6.5 “Tracing test”.
H.2.2.3.9 Button lock	<p>The tablet shall be so designed that a hardware or software lock can be provided for buttons which need to be continuously depressed for the duration of a task primitive such as dragging, tracing, or free-hand input.</p>	<p>Verify that the tablet is designed so that a hardware or software lock can be provided for buttons that need to be continuously depressed.</p>
H.2.2.5 Resolution	<p>The resolution of a tablet shall be independent of both the position of the device relative to the work surface and the position of the pointer on the display.</p>	<p>Verify that the resolution is independent of the input device position relative to the work surface and the position of the pointer on the display.</p>
H.2.3.4 Stability	<p>The base of the device shall not move unintentionally during intended use.</p>	<p>Verify that the input device does not unintentionally move during use.</p>
H.2.3.7 Non-interference of buttons with use	<p>The buttons shall be located such that their use does not interfere with the operation of the tablet.</p>	<p>Verify that the buttons can be used without interfering with the operation of the tablet.</p>
H.2.4.1 Legibility of legends	<p>All legends on tablets and overlays shall be legible from the design viewing distance.</p>	<p>Verify that the legends are legible at the design viewing distance.</p>
H.2.4.2 Minimum viewing angle	<p>The height of symbols, capital letters, and numbers on a tablet or overlay shall subtend, at minimum, 16' of visual arc at the design viewing distance.</p>	<p>Verify that the height subtends a visual angle of at least 16' of arc at the intended viewing distance.</p>
H.2.4.3 Width to height ratio	<p>The ratio of the width of a capital letter (except capital i : l) to the height of the letter shall be between 0,5 and 1,0.</p>	<p>Verify that the width to height ratio is within the specified limits.</p>

Table 18 (continued)

Attribute in ISO 9241-410: 2008	Pass/Fail criterion based on requirements and intended context of use	Measuring method
H.2.4.4 Height to stroke width ratio	The ratio of the height of a capital letter to its stroke width shall be between 5 : 1 and 14 : 1.	Verify that the height to stroke width ratios are within the specified limits.
H.2.4.5 Luminance contrast ratio	Primary legends and symbols shall have a minimum luminance contrast ratio of at least 3:1.	Verify that the contrast ratio is at least 3:1.
H.2.7 Contact with edges during use	Edges on a computer tablet shall not cause discomfort or injury. NOTE A radius of at least 2 mm on edges with which the user comes into contact and a radius of at least 3 mm on corners with which the user comes into contact will satisfy this requirement. [Modified from ISO 9241-410]	Verify that the edges with which the user is likely to come into contact for prolonged periods of time do not cause discomfort or injury.
H.2.8 Documentation of special setup requirements	If no dedicated software, e.g. a driver, is provided with the tablet, the documentation shall specify how the tablet is to be set up and to be operated in order to achieve the intended level of effectiveness and efficiency.	In that absence of dedicated software, verify that the recommended set up and operation procedures are described for the tablet.
H.3 Documentation	The user information shall include the following: — optimum location of the tablet for best effectiveness, efficiency and postural comfort; — best location of the device for concurrent use with a keyboard; — features of the hardware/software that may improve postural comfort or reduce biomechanical load. [Modified from ISO 9241-410]	Verify that the information is provided.

5.9 Styli and light-pens

Table 19 gives the design requirements for styli and light-pens.

Table 19 — Design requirements for styli and light-pens

Attribute in ISO 9241-410: 2008	Pass/Fail criterion based on requirements and intended context of use	Measuring method
<p>I.2.1.2</p> <p>Operability of the stylus/light pen</p>	<p>A stylus/light pen whose obviousness of operation is classed as C3 or C4 shall include the relevant information in its documentation; e.g. instructions or training.</p> <p>The obviousness of the stylus/light pen operation can be realized in four classes:</p> <ul style="list-style-type: none"> — C1 known or visible without additional instructions and information; — C2 detectable by the user by trial and error; — C3 learnable by simple instructions; — C4 learnable by special training. <p>[Modified from ISO 9241-410]</p>	<p>Verify that the appropriate information is present in the documentation.</p> <p>The obviousness of the stylus/light pen operation can be realized in four classes:</p> <ul style="list-style-type: none"> — C1 known or visible without additional instructions and information; — C2 detectable by the user by trial and error; — C3 learnable by simple instructions; — C4 learnable by special training.
<p>I.2.2.3.8</p> <p>Stability of the focus</p>	<p>The input device should be designed such that inadvertent button actuation does not cause unintended movement of the pointer.</p> <p>The design of the device shall ensure that actuation of any button or combination of buttons will not move the focus of the pointer.</p>	<p>Verify that actuation of any button does not move the focus of the pointer.</p>
<p>I.2.2.3.7</p> <p>Maximum button displacement</p>	<p>The maximum button displacement shall be 6 mm.</p>	<p>Verify that the maximum button displacement is ≤ 6 mm.</p>
<p>I.2.2.3.9</p> <p>Button lock</p>	<p>The stylus/light pen shall be so designed that a hardware or software lock can be provided for buttons which need to be continuously depressed for the duration of a task primitive such as dragging, tracing, or free-hand input.</p>	<p>Verify that the stylus/light pen is designed so that a hardware or software lock can be provided for buttons that need to be continuously depressed.</p>

Table 19 (continued)

Attribute in ISO 9241-410: 2008	Pass/Fail criterion based on requirements and intended context of use	Measuring method
I.2.6 Contact with edges during use	<p>Edges on a computer stylus/light pen shall not cause discomfort or injury.</p> <p>NOTE A radius of at least 2 mm on edges with which the user comes into contact and a radius of at least 3 mm on corners with which the user comes into contact will satisfy this requirement.</p> <p>[Modified from ISO 9241-410]</p>	Verify that the edges with which the user is likely to come into contact for prolonged periods of time do not cause discomfort or injury.
I.2.7 Setup requirements	If no dedicated software, e.g. a driver, is provided with the stylus/light pen, the documentation shall specify how the stylus/light pen is to be set up and to be operated in order to achieve the intended level of effectiveness and efficiency.	In that absence of dedicated software, verify that the recommended set up and operation procedures are described for the stylus/light pen.
I.3 Documentation	<p>The user information shall include the following: The manufacturer of a stylus/light pen shall provide the following information:</p> <ul style="list-style-type: none"> — optimum location of the stylus/light pen for best effectiveness, efficiency and postural comfort; — best location of the device for concurrent use with a keyboard; — features of the hardware/software that may improve postural comfort or reduce biomechanical load. <p>[Modified from ISO 9241-410]</p>	Verify that the information is provided.

5.10 Touch-sensitive screens

Table 20 gives the design requirements for touch-sensitive screens.

Table 20 — Design requirements for touch-sensitive screens

Attribute in ISO 9241-410: 2008	Pass/Fail criterion based on requirements and intended context of use	Measuring method
J.2.2.4 Glare and image quality	The area of the touch screen that includes the touch-sensitive location shall be designed to enable users to easily recognize graphic symbols, their captions, and to read alphanumeric information correctly.	Verify that the screen conforms to ISO 9241-307 with regard to glare and image quality.
J.2.3.2 Target location	Vertically oriented touch screens shall allow the touch targets to be placed below shoulder height.	Verify that the touch screen targets can be placed below the height of the user's shoulder.
J.3 Documentation	The user information shall include the following: — features of the hardware/software that may improve postural comfort or reduce biomechanical load; — instructions for cleaning.	Verify that the information is provided.

6 Conformance

The test methods specified in this part of ISO 9241 shall be used to assess conformance with the requirements of ISO 9241-410.

Annex A (informative)

Overview of the ISO 9241 series

The annex presents an overview of the structure of ISO 9241. For an up-to-date overview of its structure, subject areas and the current status of both published and projected parts, please refer to:

[ISO 9241 series](#)

The structure reflects the numbering of the original ISO 9241 standard; for example, displays were originally Part 3 and are now the 300 series. In each section, the “hundred” is an introduction to the section; for example, Part 100 gives an introduction to the software-ergonomics parts.

Table A.1 — Structure of ISO 9241 — Ergonomics of human–system interaction

Part	Title
1	Introduction
2	Job design
11	Hardware and software usability
20	Accessibility and human–system interaction
21-99	Reserved numbers
100	Software ergonomics
200	Human–system interaction processes
300	Displays and display-related hardware
400	Physical input devices — Ergonomics principles
500	Workplace ergonomics
600	Environment ergonomics
700	Control rooms
900	Tactile and haptic interactions

Annex B (informative)

Testing of efficiency and effectiveness

B.1 General

The purpose of this annex is to describe a performance test method for evaluating the efficiency and effectiveness of existing or new input devices. It is included to provide information on potential methods of testing input devices and to encourage institutions or individuals to conduct research on these methods such that further validation can be supplied.

The tests provide a measure of throughput. Because it is not possible to define a single performance test procedure that will encompass all input devices and situations of input device use, several test procedures are included in this annex.

B.2 Procedure overview

Input devices should be tested for the tasks for which they are intended to be used. The tests included in this annex are designed to evaluate the following task primitives:

- pointing;
- selecting;
- dragging;
- tracing;
- free-hand input.

It is not necessary for an input device to be tested on all task primitives unless they are all considered essential components of the job. However, valid comparisons between two or more different input devices can only be achieved if the same test method is used on each device.

No software used in the test system should interfere with a subject's performance. For example, if the system is connected to a network, notification of incoming mail should be disabled.

B.3 Special training

Due to the potential lack of familiarity with a novel input device design, subjects may require training before performance testing can be reliably conducted. In cases where training is needed, each subject should be allowed to learn the use of the input device until speed and accuracy do not show any significant improvements. Subjects should be given sufficient practice sessions to ensure that learning effects are stabilised. Thus, this should be verified by a procedure such as the Duncan's Range test.

A standard set of instructions should be given to each subject prior to starting the test. The instructions should inform subjects to work as quickly and accurately as possible and to leave errors uncorrected.

B.4 Task primitive identification and selection

Appropriate task primitive(s) (see B.2) should be identified for the intended use of the input device(s) being tested. Task-primitive variations and conditions should then be selected (see Table B.1).

Table B.1 — Task and condition variations

Task	Condition
Movement	1) One direction (<i>x</i> or <i>y</i> direction only) 2) Two directions (<i>x</i> or <i>y</i> directions only) 3) Any direction (all angles)
Feedback and prompting	1) Presence/absence of positional visual feedback 2) Presence/absence of visual prompting 3) Presence/absence of feedback for target acquisition
Target acquisition	1) Manual when the user signals acquisition to the system 2) Automatic when the user's pointing is within a present range

B.5 Calculations for input device throughput

B.5.1 Target widths

The target width (*w*) is the width of a target presented on a display.

NOTE For a selection, pointing or dragging task, the target width is measured along the direction of movement. For a tracing task, the target width is measured perpendicular to the direction of movement.

B.5.1.1 Effective target width

The effective target width (*w_e*) is the width of the distribution of selection coordinates made by a subject during a pointing/tapping test.

It is calculated as

$$w_e = 4,133 \cdot s_x \quad (\text{B.1})$$

where *s_x* is the standard deviation of the selection coordinates in the direction where movement proceeds (*x*-axis in a horizontal tapping test).

B.5.1.2 Index of difficulty

I_D is the measure, in bits, of the user precision required in a task, see 3.6.

B.5.1.3 Effective index of difficulty

The effective index of difficulty (*I_{De}*) is the measure, in bits, of the user precision achieved in accomplishing a task expressed as one of the following.

For selection, pointing or dragging tasks:

$$I_{De} = \log_2 \frac{d + w_e}{w_e} \quad (\text{B.2})$$

and for tracing tasks:

$$I_D = \frac{d}{w_e} \quad (\text{B.3})$$

where

d is the distance of movement to the target;

w_e is the target width of the displayed target.

NOTE For selection, pointing or dragging tasks, I_{De} is logarithmically related to d and w_e . For tracing tasks, I_{De} is linearly related to d and w_e .

B.5.1.4 Task precision

Task precision is the measure of the accuracy required for a pointing, selecting or dragging task primitive and quantified by I_D .

NOTE 1 Task precision can be classified into four precision levels based on the I_D :

- a) C1 high: $I_D > 6$;
- b) C2 medium: $4 < I_D \leq 6$;
- c) C3 low: $3 < I_D \leq 4$;
- d) C4 very low: $I_D \leq 3$.

A range of I_D values from 2 to 8 should be used when testing task precision.

B.5.2 Throughput calculations

The following calculations are for input throughput for selecting, pointing, dragging and tracing.

$$\text{Throughput} = \frac{\text{Effective index of difficulty}}{\text{Movement time}} = \frac{I_{De}}{t_m} \quad (\text{B.4})$$

where

I_{De} is the effective index of difficulty;

t_m is the movement time, calculated from the initiation of movement of the input device to target selection.

A graph of movement time is plotted against I_{De} and a linear relationship is obtained (see Figure B.1). The slope of the line represents the throughput of the device, in bits per second.

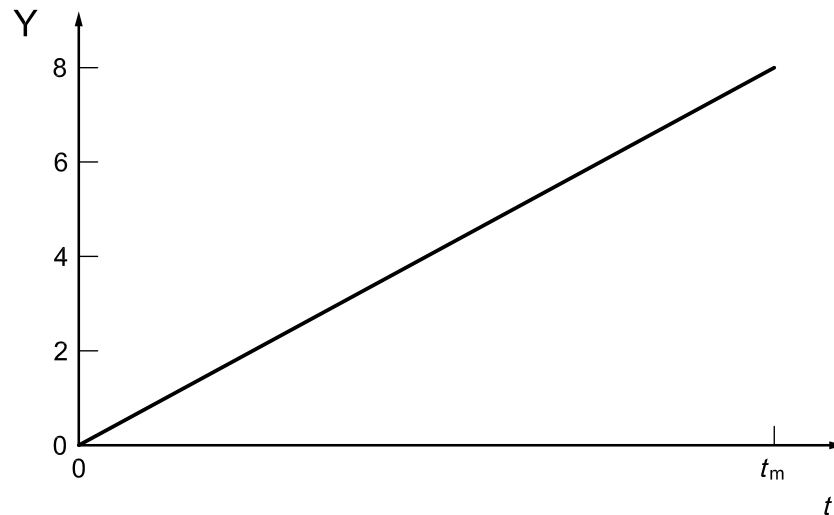

Key

t_m movement time

Figure B.1 — Relationship of index of difficulty to time

B.6 Tests

B.6.1 General

The use of the tests presented in this clause will depend on the task(s) for which the input device(s) is(are) intended to be used. In addition, the test selected will depend on the movement direction for the task, feedback and prompting, and the method of target acquisition. The test should include a range of difficulty that matches the expected use of the input device.

B.6.2 Tapping tests

B.6.2.1 One-direction tapping test

This test can be used to evaluate a pointing movement along one axis.

Its applications include

- a) a horizontal or vertical rubber-banding,
- b) an insert cursor at points along a character string, and
- c) selecting information in columns or rows.

Test procedure: Two rectangles of width w and with a centre-to-centre distance d are presented to the user (see Figure B.2). The task is to point and click, along one axis, within each rectangle 25 times. Each test session starts when the user first moves the cursor into a rectangle and actuates a button²⁾

2) Target acquisition may be either manual (for example, depression of a button) or automatic (for example, system sensing the presence of the cursor within the target area).

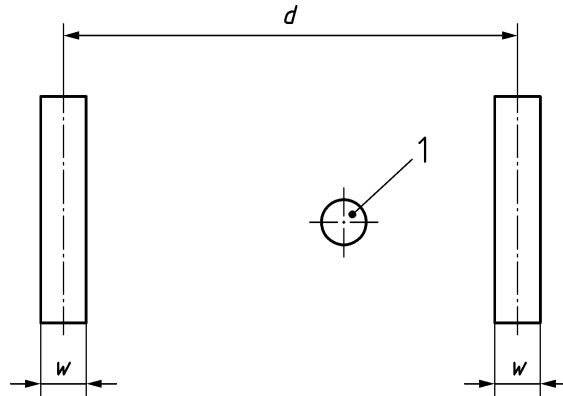

Key

- 1 pointer object
- d target distance
- w target width

Figure B.2 — One-direction tapping task

This test should be conducted with a range of difficulties, varying both the target distance (d) and the target width (w). These should be varied in equal proportions so that the effective I_D ranges from about 1 bit to 6 bits. The results should be calculated according to the equations in B.5.

NOTE I_{De} for this test is defined in B.5.1.3.

B.6.2.2 Multi-directional tapping test

This test can be used to evaluate: pointing movements in many different directions.

Its applications include

- a) repositioning a cursor at different areas on the screen,
- b) cell selection in a spreadsheet, and
- c) selecting randomly located icons.

Test procedure: The subject is required to move the cursor across a circle to sequentially numbered targets (see Figure B.3). The targets (for example: squares) should be equally spaced around the circumference of the circle.

The targets should be arranged so that the movements are nearly equal to the diameter of the circle. The targets to which the subject should advance should be highlighted. Each test session starts after the subject points to the topmost target and ends when the sequence is completed (at the topmost target).

This test should be conducted with a range of difficulties. That is, the size of the circle and thus the distance between the target squares should be varied between trials, as long as all subjects have the same test conditions.

The results should be calculated according to Equations (B.2) and (B.4).

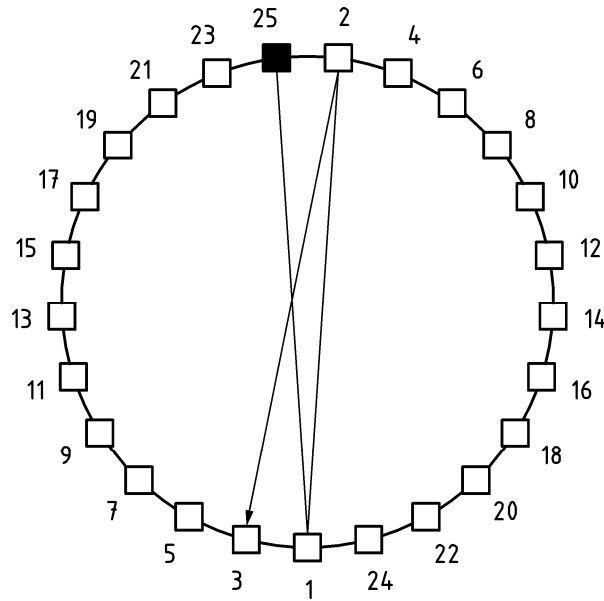

Key

1/2 start/finish

Figure B.3 — Multi-directional pointing task

B.6.3 Dragging test

This test can be used to evaluate clicking and dragging objects to specific locations.

Its applications include

- a) clicking and dragging the cursor down a pull-down menu, and
- b) selecting and dragging an object from one window to another.

Test procedure: Either the one-direction tapping test or the multi-direction tapping test can be used to calculate I_{De} . The tests are modified so that the subject is required to click on and drag the initial target to the second target. I_{De} shall be calculated using Equation (B.3).

B.6.4 Tracing test (any direction)

This test can be used to evaluate clicking and dragging objects to specific locations or to duplicate shapes.

Its applications include

- a) tracing an image (like a printed circuit board layout) on a tablet,
- b) line or picture duplication, and
- c) solid filling of objects.

Test procedure: Two concentric circles of radii r and $(r + k)$ are presented to the subject (see Figure B.5). The task is to move an object of width b within the track of width k around the circle without touching the boundary line.

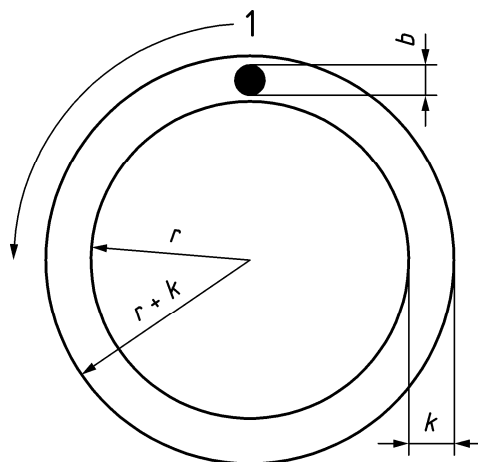

Key

- 1 start/finish
- k width of track
- b width of object
- r radius of circle

Figure B.4 — Tracing task

This test should be conducted with a range of difficulties. That is, the width of the object, width of the track and radius of the circles should be varied between trials, as long as all subjects have the same test conditions.

I_D for this test is given by:

$$I_D = \frac{d}{w} \tag{B.5}$$

where

$$w = k - b \tag{B.6}$$

The effective I_{De} for this test is given by:

$$I_{De} = d \tag{B.7}$$

where d is the mean deviation from the centre-line.

Annex C (informative)

Assessment of comfort

IMPORTANT — Tables C.1 to C.4 do not fall within the copyright of this part of ISO 9241 and may be reproduced freely.

C.1 General

Use the comfort-rating scales described in this annex to assess comfort. Providing such information on potential methods for testing input devices is aimed at encouraging institutions or individuals to conduct research on these methods such that further validation can be supplied.

This annex includes rating scales that assess comfort and usability by asking subjects to rate input devices independently and comparatively. These scales are designed so that the devices with the highest scores represent those preferred. Whichever scales are chosen for use, they should be formatted in a positive direction, with the highest values being associated with the most positive impressions.

C.2 Independent ratings

The independent rating scales (see Table C.1) can be used to assess impressions of each input device being tested. This is done after the subject completes a series of tasks with an input device. The subject draws a circle around the number that best describes his or her impression of each characteristic for the input device used. Comparative evaluations are made by comparing significant differences between devices for each item rated.

C.3 Comparative ratings

The comparative scales (see Tables C.2 and C.3) are used to determine which input device is preferred. Although designed to comparatively assess two devices, they can be expanded to be used for more than two input devices.

The response sheet is given to each subject after completing the tasks on one device (for example, device A) and again after completing the tasks on the other device (for example, device B). Subjects complete the Phase 1 rating after using the first input device. Subjects check the letter associated with the input device they are rating (“A” or “B”) and then place a mark under the column that best represents their feeling about the input device.

Subjects complete the Phase 2 rating after using the second input device, checking the letter associated with the input device being rated (“A” or “B”) and then placing a mark under the column that best represents their feelings about the second input device in comparison with the first.

Table C.1 — Independent rating scale

1. Force required for actuation:						
1	2	3	4	5	6	7
Very uncomfortable				Very comfortable		
2. Smoothness during operation:						
1	2	3	4	5	6	7
Very rough				Very smooth		
3. Effort required for operation:						
1	2	3	4	5	6	7
Very high				Very low		
4. Accuracy:						
1	2	3	4	5	6	7
Very inaccurate				Very accurate		
5. Operation speed:						
1	2	3	4	5	6	7
Unacceptable				Acceptable		
6. General comfort:						
1	2	3	4	5	6	7
Very uncomfortable				Very comfortable		
7. Overall operation of input device:						
1	2	3	4	5	6	7
Very difficult (to use)				Very easy (to use)		
8. Finger fatigue:						
1	2	3	4	5	6	7
Very high				None		
9. Wrist fatigue:						
1	2	3	4	5	6	7
Very high				None		
10. Arm fatigue:						
1	2	3	4	5	6	7
Very high				None		
11. Shoulder fatigue:						
1	2	3	4	5	6	7
Very high				None		
12. Neck fatigue:						
1	2	3	4	5	6	7
Very high				None		

Table C.2 — Dependent rating scale

General indices	Phase 1: First input device □A or □B					Phase 2: Second input device □A or □B		
	Most negative		Most positive			Worse	Same	Better
	1	2	3	4	5	-1	0	+1
1. Actuation force								
2. Operation smoothness								
3. Operation effort								
4. Accuracy								
5. Operation speed								
6. General comfort								
7. Overall operation								
Fatigue indices	First input device □A or □B					Second input device □A or □B		
	Extreme		None			Worse	Same	Better
	1	2	3	4	5	-1	0	+1
8. Finger fatigue								
9. Wrist fatigue								
10. Arm fatigue								
11. Shoulder fatigue								
12. Neck fatigue								

C.4 Assessment of effort

Rating scales of perceived effort can be used to quantify subjective opinions about the level of effort a given input device (or task) requires. One example is the Borg scale, which was designed for use in collecting opinion data about the level of whole-body effort and effort in large muscle groups such as the arm, shoulder and neck and which thus may not be appropriate for small muscles used in fine precision movements.

The Borg scale has 12 points (see Table C.3). The points represent the percentage of maximum muscular strength — the maximum voluntary muscle contraction (MVC) as a percentage — that a given effort requires. The descriptors in the scale relate to muscle work; whole-body-effort descriptors are included in parentheses.

Table C.3 — Borg scale

Points	Effort representation
() 10	Very, very strong (almost max.)
() 9	
() 8	
() 7	Very strong
() 6	
() 5	Strong (heavy)
() 4	Somewhat strong
() 3	Moderate
() 2	Weak (light)
() 1	Very weak
() 0,5	Very, very weak (just noticeable)
() 0	Nothing at all

For the purposes of this annex, the Borg scale can be formatted as in Table C.4.

Table C.4 — Borg scale for arm, shoulder, and neck effort

Effort			Effort
Arm	Shoulder	Neck	
() 10	() 10	() 10	Very, very strong (almost max.)
() 9	() 9	() 9	
() 8	() 8	() 8	
() 7	() 7	() 7	Very strong
() 6	() 6	() 6	
() 5	() 5	() 5	Strong (heavy)
() 4	() 4	() 4	Somewhat strong
() 3	() 3	() 3	Moderate
() 2	() 2	() 2	Weak (light)
() 1	() 1	() 1	Very weak
() 0,5	() 0,5	() 0,5	Very, very weak (just noticeable)
() 0	() 0	() 0	Nothing at all

C.5 Statistical analysis

The rating assessments described in C.1 and C.2 employ rating scales that yield interval-scale data. Given that the proper underlying assumptions are met, standard analysis of variance statistical techniques can be used to analyse this data. However, in instances where the necessary assumptions are not met (i.e. with small sample sizes or non-normal distributions), non-parametric techniques of hypothesis testing should be used and tend to be computationally less complex.

Annex D (informative)

Usability test for keyboards

D.1 Alternative test method for determining compliance

D.1.1 General

This test method may be used as an alternative for evaluating the performance and comfort of keyboards which do not meet all of the requirements given in Tables 1 to 12 of this part of ISO 9241. It is primarily intended to help designers and/or manufacturers of innovative keyboards to assess the usability of their designs, thus encouraging the exploration of new keyboard concepts. The test methodology described may also be used by test agencies and user organizations who need to determine whether a particular keyboard meets the performance criteria of this part of ISO 9241.

NOTE Testing organizations are requested to indicate their experience with this technique together with supporting documentation, in particular the statistical methods employed.

D.1.2 Statement of usability

Usability is a consideration in the design of keyboards concerned with the extent to which users of keyboards are able to work effectively, efficiently and with satisfaction. For the purpose of this part of ISO 9241, effectiveness and efficiency are addressed by the performance measures (e.g. keying rate or error rate) and satisfaction by the assessment of comfort.

D.1.3 Overview of the test procedure

The test procedure includes two tasks: text entry and data entry. The keyboard should be tested with the task which represents its intended use. It is not necessary for a keyboard to be tested on both tasks; however, a general purpose keyboard that will be used for both text and data entry is required to pass both tests.

In addition to the keyboard being tested (hereafter referred to as the “test keyboard”), a “reference keyboard” that meets all of the requirements in Clause 6, using the direct measurement approach, should be used for comparison.

For both text and data entry, the test procedure involves setting up the keyboard and a monitor so that typed characters are displayed on the monitor. Test subjects perform specified text or data entry tasks while performance measures are obtained. Upon completion of the text or data entry task, subjects complete a questionnaire designed to assess subjective measures of comfort. This basic procedure is performed twice, once for the test keyboard and once for the reference keyboard.

The test keyboard meets the performance criteria of this part of ISO 9241 if performance and subjective measures of comfort are equivalent to those obtained from the reference keyboard.

D.1.4 Subjects

Test subjects should be representative of the anticipated user population(s). User variables such as gender, age range, visual characteristics (use of corrective lenses), handedness, should be considered when selecting the subject sample. In addition, the keying proficiency of the sample should match that of intended users. The subjects should be fluent in the language for which the keyboard is intended.

Perform a strength of association test to determine the appropriate sample size necessary to achieve the desired minimum detectable difference or statistical level of significance and report the result.

D.1.5 Apparatus

The test system should be capable of

- a) displaying typed characters on a monitor,
- b) displaying typed information consecutively (no page breaks),
- c) capturing and storing keystrokes,
- d) timing sessions,
- e) printing or displaying typed information so that keystrokes and errors can be counted.

The monitor(s) used for the test should meet all of the requirements in the ISO 9241-300 series. Preferably, the same monitor should be used for displaying the keyed characters for both the test and reference keyboards. If different monitors are used, both should have the same polarity. The appearance of the fonts should match.

Any software used in the test should not interfere with the subjects' performance. For example, if the system is connected to a network, notification of incoming mail should be disabled.

D.1.6 Test materials

D.1.6.1 General

All test materials should be presented as dark text or numbers on white paper. The format of the test materials should match the capabilities of the monitor as closely as possible, i.e. printed text or data should match displayed text or data in terms of font, spacing, line width, line justification, etc.

D.1.6.2 Text entry

D.1.6.2.1 Content

Text should consist of continuous complete sentences. The level of difficulty of the vocabulary should not be beyond the reading ability of the subjects. A practical method is to use material written for 12 year olds. The text should be neutral in content (not political or religious) and should not be too technical or scientific. The text should be free of spelling and grammatical errors and should be correctly punctuated.

The text should be in the usual language of the target user population.

D.1.6.2.2 Format

The format of the test material should be double-spaced lines of continuous text. The text should not contain indentations or special representation of the characters such as italicized, bold or underlined.

D.1.6.3 Data entry

D.1.6.3.1 Content

Data should consist of sets of randomly chosen letters or digits.

D.1.6.3.2 Format

The material should be arranged in five groups per page. A group should consist of five lines, each consisting of groups made up of seven letters or seven digits.

D.1.7 Pretesting

Prior to the test, each subject should be tested to verify his/her typing or data entry speed. This test should be performed using the reference keyboard. In addition, all subjects should be given a vision test to ensure that they can see adequately to participate in the test.

D.1.8 Special training

Due to the potential lack of familiarity with the test keyboard, subjects may require an extended period of training before performance and subjective ratings of comfort can be reliably obtained. Each subject should be allowed to train on the test keyboard until his/her typing speed and accuracy are asymptotic, or show no significant improvements.

D.1.9 Test environment

D.1.9.1 General

The test area should be quiet and free from distractions. Ideally it should be located in a dedicated test area such as a usability laboratory.

D.1.9.2 Noise

Ambient noise, measured at the subject's seated position, should be below 55 dB A-weighted.

D.1.9.3 Thermal environment

Ambient air temperature should be between 19 °C and 26 °C. The relative humidity should be between 40 % and 60 %. Air velocity should be < 0,15 m/s.

D.1.9.4 Lighting

Ambient illuminance incident upon the horizontal plane should be a minimum of 250 lx

The character or background luminance (whichever is higher) of the display should be at least 35 cd/m² while maintaining a contrast of at least 3:1. Any glare on the display from lighting fixtures or windows should be minimized.

Recommended values for surface reflectance are given in Table D.1.

Table D.1 — Reflectance of surfaces

Surface	Reflectance
Ceiling	0,6 to 0,8
Walls	0,3 to 0,5
Floor	0,2 to 0,3
Furniture	0,2 to 0,5

Test subjects should be adapted to the test environment (or an equivalent one) for at least 15 min prior to the test.

D.1.10 Test workstation

The workstation should meet all the requirements of ISO 9241-5, including the following:

- a) chair with adjustable seat height and a stable base;
- b) adjustable height desk.

An adjustable height work surface is not required but the work surface in test procedures should fit the user as recommended in ISO 9241-5.

- c) adjustable monitor such that the input lines are situated between 20° and 45° below the test subject's horizontal line of sight;
- d) document holder;
- e) foot rest.

If the test keyboard requires specialized furniture, that furniture should be used.

D.1.11 Test procedure

D.1.11.1 Order of presentation

Each test subject should be tested using each keyboard, once using the test keyboard and once using the reference keyboard. The keyboards should be labelled anonymously (for example, "A" and "B"). The order of presentation should be counterbalanced to eliminate any effects due to test order.

D.1.11.2 Length of sessions

The test should consist of subjects keying on each keyboard for six 5 min sessions with a 5 min break between sessions. The first two are practice sessions.

D.1.11.3 Test material

There should be sufficient test material, so that test subjects do not repeat the entry of any text or data throughout the entire test.

NOTE 1 The test material should be representative of the language used.

NOTE 2 Test subjects' typing skills are discussed in D.1.3.

D.1.11.4 Instructions

A standard set of instructions should be given to each subject prior to starting the test. The instructions should inform subjects to work as quickly and accurately as possible and to leave errors uncorrected.

D.1.11.5 Confidentiality

Confidentiality of an individual's performance should be assured. Performance scores which reveal an individual subject's identity should not be released by the testing organization. Rules governing the ethical conduct of human experimentation should be followed.

D.1.12 Assessment of keyboard performance and comfort

D.1.12.1 Performance measures

Using data obtained from sessions 3, 4, 5, and 6, the following measures should be analysed.

- a) Keying rate. This is the total number of words or characters typed per minute during each 20 min session. For text entry, word count is calculated by counting the number of characters typed and dividing by 5. Words-per-minute are calculated by the word count divided by 20. For data entry, characters-per-minute are calculated by dividing the number of characters by 20.
- b) Error rate. For text entry, calculate the number of words containing one or more errors by counting the number of absolute errors. For both text and data entry, errors should include omissions, insertions and commissions (wrong character).

Each of these measures should be statistically analysed. All statistical procedures should use an alpha level of $\geq 0,05$.

D.1.12.2 Subjective assessment of comfort

Immediately following the last entry session for each keyboard, subjects should be given a questionnaire designed to elicit subjective ratings of comfort for that keyboard. The questionnaire provided in this annex should be used.

Questionnaire responses should be statistically analysed. All statistical procedures should use an alpha level of $\geq 0,05$.

D.2 Assessment of comfort questionnaire

For each rating in Table D.2, circle one number in each rating line that best describes your impression of the characteristic of the keyboard you have just used.

Table D.2 — Independent rating scale

1. Force required to activate the keys:						
1	2	3	4	5	6	7
Excessive				Acceptable		
2. Keying rhythm:						
1	2	3	4	5	6	7
unacceptable				Acceptable		
3. Fatigue in hands or wrists:						
1	2	3	4	5	6	7
Very high				Very low		
4. Fatigue in arms:						
1	2	3	4	5	6	7
Very high				Very low		
5. Fatigue in shoulders:						
1	2	3	4	5	6	7
Very high				Very low		

Table D.2 (continued)

6. Posture required for keying:						
1	2	3	4	5	6	7
Very uncomfortable				Very comfortable		
7. Overall use:						
1	2	3	4	5	6	7
Very difficult (to use)				Very easy (to use)		

Operator comments:

D.3 Examples of material for data entry (English language)

See Table D.3.

Table D.3 — Example of material for data entry (English language)

Alpha data	Numeric data
SOENFIL	2017947
OAPICAI	9329450
TOZNBHT	1623337
MTODSRI	1361489
EIFRESG	2756490
TESBLTO	4905087
KYORSWT	2586728
RSWETOE	0104652
FRBGECE	7498501
OSQETYH	6417180
USIPROZ	7925381
TSNKLXE	0891273
TYAPAU	4209317
DTIAOMI	1876504
ECVRNBT	7580893
GHWQANT	2735018
DSGBEFR	5873642
BHIFRWN	6098971
CSAYLUS	1240354
ADHTCNI	4769016
LEURMNM	5187638
TICNOWL	1754520
XBIAJDM	9357216
HSNCIEV	6489571
POASCRT	2758096

Bibliography

- [1] ISO 9241-6, *Ergonomic requirements for office work with visual display terminals (VDTs) — Part 6: Guidance on the work environment*
- [2] ISO 9995-7, *Information technology — Keyboard layouts for text and office systems — Part 7: Symbols used to represent functions*
- [3] ISO 11690-1, *Acoustics — Recommended practice for the design of low-noise workplaces containing machinery — Part 1: Noise control strategies*
- [4] IEC 68-2-70, *Environmental testing — Part 2: Tests — Test Xb: Abrasion of markings and letterings caused by rubbing of fingers and hands*

British Standards Institution (BSI)

BSI is the national body responsible for preparing British Standards and other standards-related publications, information and services.

BSI is incorporated by Royal Charter. British Standards and other standardization products are published by BSI Standards Limited.

About us

We bring together business, industry, government, consumers, innovators and others to shape their combined experience and expertise into standards-based solutions.

The knowledge embodied in our standards has been carefully assembled in a dependable format and refined through our open consultation process. Organizations of all sizes and across all sectors choose standards to help them achieve their goals.

Information on standards

We can provide you with the knowledge that your organization needs to succeed. Find out more about British Standards by visiting our website at bsigroup.com/standards or contacting our Customer Services team or Knowledge Centre.

Buying standards

You can buy and download PDF versions of BSI publications, including British and adopted European and international standards, through our website at bsigroup.com/shop, where hard copies can also be purchased.

If you need international and foreign standards from other Standards Development Organizations, hard copies can be ordered from our Customer Services team.

Subscriptions

Our range of subscription services are designed to make using standards easier for you. For further information on our subscription products go to bsigroup.com/subscriptions.

With **British Standards Online (BSOL)** you'll have instant access to over 55,000 British and adopted European and international standards from your desktop. It's available 24/7 and is refreshed daily so you'll always be up to date.

You can keep in touch with standards developments and receive substantial discounts on the purchase price of standards, both in single copy and subscription format, by becoming a **BSI Subscribing Member**.

PLUS is an updating service exclusive to BSI Subscribing Members. You will automatically receive the latest hard copy of your standards when they're revised or replaced.

To find out more about becoming a BSI Subscribing Member and the benefits of membership, please visit bsigroup.com/shop.

With a **Multi-User Network Licence (MUNL)** you are able to host standards publications on your intranet. Licences can cover as few or as many users as you wish. With updates supplied as soon as they're available, you can be sure your documentation is current. For further information, email bsmusales@bsigroup.com.

BSI Group Headquarters

389 Chiswick High Road London W4 4AL UK

Revisions

Our British Standards and other publications are updated by amendment or revision.

We continually improve the quality of our products and services to benefit your business. If you find an inaccuracy or ambiguity within a British Standard or other BSI publication please inform the Knowledge Centre.

Copyright

All the data, software and documentation set out in all British Standards and other BSI publications are the property of and copyrighted by BSI, or some person or entity that owns copyright in the information used (such as the international standardization bodies) and has formally licensed such information to BSI for commercial publication and use. Except as permitted under the Copyright, Designs and Patents Act 1988 no extract may be reproduced, stored in a retrieval system or transmitted in any form or by any means – electronic, photocopying, recording or otherwise – without prior written permission from BSI. Details and advice can be obtained from the Copyright & Licensing Department.

Useful Contacts:

Customer Services

Tel: +44 845 086 9001

Email (orders): orders@bsigroup.com

Email (enquiries): cservices@bsigroup.com

Subscriptions

Tel: +44 845 086 9001

Email: subscriptions@bsigroup.com

Knowledge Centre

Tel: +44 20 8996 7004

Email: knowledgecentre@bsigroup.com

Copyright & Licensing

Tel: +44 20 8996 7070

Email: copyright@bsigroup.com



...making excellence a habit.™