

PAS 3621:2011



BSI Standards Publication

Multipoint locking assemblies – Keyed egress – Performance requirements and test methods



NO COPYING WITHOUT BSI PERMISSION EXCEPT AS PERMITTED BY COPYRIGHT LAW

raising standards worldwide™



Publishing and copyright information

The BSI copyright notice displayed in this document indicates when the document was last issued.

© BSI 2011

ISBN 978 0 580 64592 1

ICS 13.310; 91.190

The following BSI reference relates to the work on this standard:
Committee reference ZZ/1

Publication history

First published June 2011

Amendments issued since publication

Date	Text affected
------	---------------

Contents

Foreword *iii*

Introduction 1

1	Scope	1
2	Normative references	2
3	Terms and definitions	2
4	Classification of locking assembly characteristics	4
5	Requirements	6
6	Test conditions	13
7	Test methods	17
8	Marking	31

Annexes

Annex A (normative) General vulnerability assessment 33

Annex B (normative) Product Information 37

Annex C (normative) Test sampling and sequencing 40

List of figures

Figure 1 – Typical load test rig 10

Figure 2 – Example clenching side seal load 14

Figure 3 – Typical load test rig 15

Figure 4 – Example configuration for Test Door 16

Figure 5 – Typical load test rig (5a) with detail of application tool (5b) 18

Figure 6 – Section through test door 19

Figure 7 – Typical sliding door test rig 19

Figure 8 – Application of side load for latch durability tests 22

Figure 9 – Typical load test rig (9a) with detail showing application of tool (9b). 23

Figure 10 – Typical drilling apparatus 24

Figure 11 – Typical load test jig 25

Figure 12 – Typical arrangement for testing the security of the locking plate 26

Figure 13 – Typical test rig for anti-separation 29

Figure 14 – Typical test jig for 'Disengaging Force' test 30

Figure 15 – Typical test rig for pulling on locking plates 30

Figure 16 – Typical test rig for lifting locking plates 31

Figure B.1 – Example of the illustration required under j) above 39

List of tables

Table 1 – Required lock assembly characteristics and relevant clauses 5

Table 2 – Durability requirements 8

Table 3 – Security Requirements 9

Table A.1 – List of tools permitted for use in the general vulnerability assessment 35

Table C.1 – Testing sampling and sequencing 40

Summary of pages

This document comprises a front cover, an inside front cover, pages i to iv, pages 1 to 40, an inside back cover and a back cover.

Foreword

Publishing Information

This Publicly Available Specification (PAS) has been prepared by BSI to specify performance requirements and test methods for multipoint locking assemblies with keyed egress and came into effect in June 2011. The development of this PAS was sponsored by the Door and Hardware Federation (DHF).

Relationship with other Standards

This PAS refers to BS EN 1303:2005, BS EN 12209:2003, BS 3621:2007 and prEN 15685

Attention is drawn to the fact that BS EN 12209: 2003 takes fully into account the regulatory requirements of the EU Construction Products Directive (89/106/EEC) which is implemented in the UK as the Construction Products Regulations 1991.

This PAS is complemented by PAS 8621: 2011, *Multipoint locking assemblies – Keyless egress*, and by PAS 10621: 2011 *Multipoint locking assemblies – Dual mode operation*, published simultaneously.

Information about this PAS

This PAS provides for lock assemblies that may incorporate a cylinder, with the intention of providing a good standard of attack resistance, particularly in respect of emergent criminal techniques.

For security purposes, there is a need to maintain confidentiality about some characteristics of a thief resistant lock assembly. Moreover, in order to assess a lock's capability of withstanding a criminal attack, it is necessary for it to be exposed to skilled manual testing that simulates such an attack. Such a simulation cannot, by its very nature, be codified so as to be fully reproducible in all circumstances, and for these reasons a formal test method is not published in this PAS.

Instead, the PAS requires that lock cylinders and lock assemblies, for which conformity to this PAS is claimed, be submitted to a panel of expert assessors to be examined and assessed for their general vulnerability. Details of this examination vary according to the design and type of lock assembly.

These details appear in the Annex A which should be regarded as Normative for the purpose of designing and constructing products in conformity with this PAS.

This PAS is drafted in a manner that enables manufacturers to undertake their own assessments and make declarations of conformity, accordingly. Requirements concerning the necessary qualifications for personnel undertaking such assessments are specified in Annex A.

Acknowledgement is given to the organizations who were involved in the development of this specification as members of the Steering Group.

The Door and Hardware Federation (DHF)

The ASSA ABLOY Group

Grouphomesafe Ltd

Secured by Design

Acknowledgement is also given to the members of the wider Review Panel consulted in the development of this specification.

BSI retains ownership and copyright of this PAS and reserves the right to withdraw or amend it on receipt of authoritative advice that it is appropriate to do so.

The PAS process enables a specification to be developed rapidly in order to fulfill an immediate need in industry or in the wider community. The methodology includes a commitment to review the published PAS at intervals not exceeding two years in order to ensure its continued relevance and accuracy and because of this the PAS will be found to have particular benefit in relation to subjects where concepts and technology are as yet untried. This review may lead to confirmation, revision or withdrawal in accordance with perceived need. Any amendments arising from the review will be published as an amended PAS and publicized in *Update Standards*.

Alternatively, a PAS may be considered for further development as a British Standard, or constitute part of the UK input to the development of a European or International Standard.

This PAS is not to be regarded as a British Standard. It will be withdrawn upon publication of its content in, or as, a British Standard or if an equivalent European standard is published.

Use of this document

It has been assumed in the preparation of this PAS that the execution of its provisions will be entrusted to appropriately qualified and experienced people, for whose use it has been produced.

Presentational conventions

The provisions of this PAS are presented in roman (i.e. upright) type. Its requirements are expressed in sentences in which the principal auxiliary verb is "shall".

Commentary, explanation and general informative material is presented in smaller italic type, and does not constitute a normative element.

Contractual and legal considerations

This publication does not purport to include all the necessary provisions of a contract. Users are responsible for its correct application.

Compliance with this PAS cannot in itself confer immunity from legal obligations.

Introduction

Experiences relating to security and environmental conditions encountered in residential, commercial and public buildings have indicated a need to provide, in some applications, additional locking points to locks installed on doors, window doors and entrance doors.

These additional locking points, anti-separation points and/or clenching points are designed to ensure sufficient performance, weather tightness and/or attack resistance of doors.

In developing PAS 3621, the objectives were:

- To provide specification for a Multipoint Locking Assembly with keyed egress that is broadly equivalent in terms of security to the single point lock (BS 3621) already in place, where the door design is no part of the lock performance standard.
- To have the strength of the Multipoint Locking Assembly manufactured to PAS 3621: 2011 to be broadly comparable to that of the single point lock defined by BS 3621 but making provision for multiple locking/ security points.
- To establish a standard that will not conflict with the European Standard (EN 15685) currently being developed by CEN that will therefore be able to co-exist with that standard, when it is published. The current draft of the European Standard prEN 15685 provides a series of attribute options from which selection can be made to deliver several different grades of multipoint locking assembly all meeting the requirements of the standard. PAS 3621 identifies a set of specific attributes from the options provided for in the draft European Standard to deliver a single specification for a particular level of security. To do this it draws upon the relevant requirements and test methods currently included in prEN 15685 in order to ensure as far as may be practicable that alignment with the eventual European Standard is achieved.
- It should be noted however that as is the case with BS 3621, PAS 3621 includes requirements relating to cylinders, security furniture and general vulnerability assessment, which are outside the scope of the European Standard.

1 Scope

This PAS specifies performance requirements and test methods for mechanically operated multipoint lock assemblies with keyed egress including locking plates, fitting instructions, cylinders and protective furniture, where supplied as part of the lock assembly, used in doors, window doors and entrance doors of buildings.

This PAS is not applicable to lock assemblies that provide:

- keyless egress i.e. that can always be opened from the inside without the need for a key (PAS 8621: 2011)
- a secure (no egress) mode in addition to keyless egress (PAS 10621: 2011).

2 Normative references

The following referenced documents are indispensable for the application of this document. For these dated references, only the edition cited applies.

BS EN 1670: 2007 Building hardware – Corrosion resistance – Requirements and test methods.

ISO 10899 1996: High-speed steel two-flute drills – Technical specifications.

BS 3621: 2007 + A1 2009 Thief resistant lock assembly – Key egress.

BS EN 1303: 2005 Building hardware – Cylinders for locks – Requirements and test methods.

BS EN 12209: 2003 Building hardware. Locks and latches. Mechanically operated locks, latches and locking plates. Requirements and test methods

PAS 24:2007+A2:2011 Enhanced security performance requirements for door assemblies – Single and double leaf, hinged external door assemblies to dwellings.

3 Terms and definitions

To facilitate uniformity of application and understanding, a common set of terms and definitions is included in this standard, in PAS 8621 and in PAS 10621. The following terms and definitions are relevant to the understanding of all three standards although an individual term may not appear in all three documents.

3.1 anti-separation point

arrangement of components to prevent the separation of a door leaf from its frame or adjacent door leaf in the plane of the door

3.2 centrally controlled

having operation of all of its locking and/or clenching and/or anti-separation points, effected, enabled or prevented from a single lock case

3.3 clenching point

arrangement of components to draw together a door and its frame in the door closing direction to reduce distortion of the door and/or compress seal (not necessarily a locking point)

3.4 case

part of a lock or latch in which the lock mechanism and/or latch action is housed

3.5 cylinder

device, usually separate from, but engaging with, its associated lock or latch, that contains the parts operated by the key

3.6 cylinder lock

lock in which the lock mechanism is operated by one or more cylinders

3.7 deadbolt

moveable part of a lock that usually engages a component fixed to a frame, and withdraws into a lock case that is operated at least in one direction by a key, handle and/or thumb turn

- 3.8 deadlocking**
action of moving a deadbolt to a thrown position where pushing back of the deadbolt is positively prevented
- 3.9 manual deadlocking**
deadlocking where movement of the deadbolt is by key or handle/thumb turn
- 3.10 secure manual deadlocking (n):**
manual deadlocking in which continuous light pressure is applied to the deadbolt in the direction of deadbolt withdrawal
- 3.11 automatic deadlocking**
deadlocking where deadbolt or deadlocked latch movement is self propelled, and is triggered by the proximity of the locking plate
- 3.12 detaining element**
part of a moveable member which is moved by the key into a pre-determined position in order for the deadbolt or deadlocked latch to be able to move into an open position
- 3.13 differ**
variation between lock mechanisms of similar design, achieved by the detaining elements, which allows each lock to be operated by its own key
- 3.14 effective differ**
difference between lock or key recognition systems of similar design achieved only by the detaining elements which allows each lock or key recognition systems to be operated only by its own key. The number of effective differs is equal to the number of theoretical differs after deduction of the differs suppressed by the manufacturer due to technical constraints
- 3.15 door leaf**
part of a door that is hinged and opens to allow entry/egress of an enclosed space
- 3.16 face plate (also known as face bar)**
part of a lock through which the lock and/or locking points are fixed to the door and through which the latch and/or deadbolt pass
- 3.17 follower**
part of a lock that operates the latch bolt and/or deadbolt(s) and/or clenching and/or anti-separation points when turned by a spindle
- 3.18 interlinked**
connected for the purpose of operation
- 3.19 key**
device that is removable and portable and used to operate the lock or latch
- 3.20 latch**
self engaging fastener which secures a moveable component (eg door) in a closed position and which can be released by hand
- 3.21 latch action**
arrangement and performance of the constituent parts that operate a latch bolt

- 3.22 latch bolt**
spring-loaded moveable part of a lock that usually engages a component fixed to a frame, and withdraws into a lock case, automatically engaging a locking plate to keep the door in its closed position
- 3.23 lock**
fastener which secures a door leaf in its closed position and which is operated by a key or other device
- 3.24 lock case**
part of a lock in which the lock mechanism is housed
- 3.25 locking plate**
lock component, which is normally fixed to a door frame to engage at least a deadbolt or latch bolt or an anti-separation point or a clenching point
NOTE Alternative terms for this are strike plate or keep or staple
- 3.26 locking point**
arrangement of lock components interactant between a deadbolt or anti-separation point and locking plate for security purposes
- 3.27 lock mechanism**
constituent parts of a lock that operate at least a deadbolt or latch bolt or an anti-separation point or a clenching point and, where required, provide the differs
- 3.28 locking snib**
device, usually in the form of a small lever or knob, which can be operated to prevent the deadbolt or latch bolt from being thrown or withdrawn, or to change the function of a lock or latch
- 3.29 slave Lock**
lock assembly that is installed in the slave leaf of a double leaf door (i.e. french door)
- 3.30 multipoint lock**
lock comprising two or more points of interaction (security, anti-separation or clenching) interlinked and centrally controlled, where at least two points are more than 200 mm apart in locked or thrown position
- 3.31 night latch action**
latch action in which withdrawal of the latch bolt from the outside is only by means of a key, and from the inside only by means of a handle or knob
- 3.32 rim lock**
lock for fixing on the surface or a door leaf
- 3.33 shared latch action**
latch action in which withdrawal of the latch bolt is by means of a handle and key

4 Classification of locking assembly characteristics

4.1 General

Mechanically operated multipoint locks and their locking plates for which conformance to this standard is claimed, shall be classified in accordance with the nine-digit system specified in Table 1.

4.2 Definition of lock characteristics identified in Table 1

4.2.1 Mechanical operation (first digit)

Operational characteristics for closures intended for use by people with some incentive to exercise care but where there is some chance of misuse, e.g. office doors.

4.2.2 Durability (second digit)

Classification criteria: 200 000 test cycles; 25 N load on latch bolt.

NOTE The above information relates to latch action only. Corresponding durability requirements based on number of cycles, apply to the locking point(s), anti-separation point(s), clenching point(s) and snib mechanisms as shown in Table 2.

4.2.3 Door mass and closing force (third digit)

Classification criteria: Up to 100 kg door mass; 25 N maximum closing force.

Table 1 Required lock assembly characteristics and relevant clauses

	Characteristics grade identification sequence								
	1	2	3	4	5	6	7	8	9
Relevant Clauses	4.2.1 5.2 6 & 7.1	4.2.2 5.3 6 & 7.2	4.2.3 5.4 6 & 7.3	4.2.4 None	4.2.5 5.7 6 & 7.6	4.2.6 5.5 6 & 7.4	4.2.7 5.6 6 & 7.5	4.2.8 5.8 6 & 7.10	4.2.9 5.9 6 & 7.2.4
Characteristics	Mechanical operation	Durability	Door mass & closing force	Suitability for use on fire/smoke doors	Key identification of lever locks (see also Note 2)	Corrosion & temperature resistance	Security of locking points	Security and Anti-separation	Clenching
Lever lock Classification Code (EN 15685)	2	M	4	O	B	G	5	5	2

NOTES to Table 1

NOTE 1 Relationship with prEN 15685. The particular characteristics identified for this PAS are derived from the grade range provided for in prEN 15685 and define the minimum performance required of a lock claimed to conform to this PAS. A lock meeting the requirements of this PAS will therefore also meet the same combination of requirements of prEN 15685.

NOTE 2 Cylinders. For a cylinder lock the classification grade is 0. For cylinder requirements for cylinder locks see 5.1.7

NOTE 3 Fire & smoke (Classification digit 4, prEN 15685) Lock assemblies for which conformance to this PAS is claimed are not intended for use in smoke fire door assemblies, **consequently there are no supporting clauses for column 4 in this PAS.**

NOTE 4 Safety Lock assemblies for which conformance to this PAS is claimed are not intended for use in emergency exits. See BS EN 179 and BS EN 1125 for requirements for multipoint locks and locking plates suitable for application as part of exit devices for use on emergency or panic exit doors.

4.2.4 Suitability for use on fire/smoke doors (fourth digit)

See note 3 to Table 1

4.2.5 Key identification of lever locks (fifth digit)

Minimum five detaining elements.

4.2.6 Corrosion and temperature resistance (sixth digit)

Classification criteria: Very high corrosion resistance; temperature requirement: from -25 ° to + 70 °C.

4.2.7 Security of Locking Points (seventh digit)

Classification criteria: High security with drill resistance.

4.2.8 Anti-separation (eighth digit)

Classification criteria: High performance with drill resistance.

NOTE Anti-separation requirements and drill resistance are identified in accordance with 5.8 The classification includes anti-separation performance integrated in the locking point or as a separate anti-separation point.

4.2.9 Clenching (ninth digit)

Classification criterion: Clenching force = 25 N.

5 Requirements

5.1 General

5.1.1 Essential characteristics

Mechanically operated multipoint locks and their locking plates for which conformance to this standard is claimed shall embody the characteristics identified in **Table 1**, and specified in **Clauses 4** and **5** and be accompanied by the information specified in **Annex B**.

5.1.2 Key Operation

The lock shall be lockable with a single turn of the key of not more than 360°.

5.1.3 Strength of key (other than cylinder keys meeting the requirements of EN 1303)

When tested in accordance with **7.8.1**, the key shall resist a torque of: 2,5 Nm. The key shall operate in the lock correctly after this test in accordance with **5.2.4**.

5.1.4 Minimum locking points for door types

- A multipoint lock assembly complying with this PAS, including those intended for use with sliding type doors shall have a minimum of 3 locking points each of which shall incorporate anti-separation

characteristics. Where a lock assembly has more than 3 locking points the additional points may be without anti-separation.

- A multipoint slave lock assembly shall have a minimum of 2 locking points.

5.1.5 Dangerous substances

Materials in multipoint locks and their locking plates shall not release any dangerous substances in excess of the maximum levels specified in any relevant European Standard for the material.

NOTE The manufacturer may exercise control by monitoring raw materials/components used to verify compliance.

5.1.6 Product Information

Locking assemblies claimed to be in conformance with this PAS shall be accompanied by product information (**Annex B**).

5.1.7 Cylinders

Cylinders for multipoint cylinder locks shall be as specified in BS 8621:2007+A1:2009 (Clause 5).

5.2 Mechanical operation

5.2.1 Strength of bolt action

When tested in accordance with 7.1.1 the locking point and clenching point components shall resist a torque of 30 Nm and the latch bolt components shall resist a torque of 20 Nm. The lock shall operate correctly after this test and conform to 5.2.4.

5.2.2 Return force of latch bolts

When tested in accordance with 7.1.2 the return force of the latch bolt shall not be less than 2.5 N.

5.2.3 Resistance to side load on latch bolt

When tested in accordance with 7.1.3 each latch bolt shall resist a side load of 3 kN.

5.2.4 Lock operation torques

5.2.4.1 The lock shall conform to 5.2.4.2 to 5.2.4.5 inclusive, when tested in accordance with 7.1.4.

5.2.4.2 The torque on the follower to operate the latch bolt, locking point(s) or anti-separation point(s) shall not exceed 7 Nm.

5.2.4.3 The torque on the follower to operate the clenching point shall not exceed 7 Nm with the clenching force applied.

5.2.4.4 The torque on the key to operate the latch bolt, locking point(s) or anti-separation point(s) shall not exceed 1.0 Nm.

5.2.4.5 The torque on the key to operate the clenching point shall not exceed 1.0 Nm with the clenching force applied.

5.2.4.6 When tested in accordance with 7.1.6 the locked follower shall resist a torque of 60 Nm. The lock shall be operable after this test.

5.2.4.7 When tested in accordance with 7.5.1 with between 61 and 150 Nm of torque it shall not be possible to force the lock open. The lock does not need to be operable after this test.

5.2.4.8 When tested in accordance with 7.1.1.4 the restoring torque on the follower shall be: >0.8 Nm.

5.2.5 Strength of follower stops

When tested in accordance with 7.1.5, the latch components and follower stops shall resist a torque of 40 Nm. The latch action shall function correctly after this test, fulfilling the requirement of 5.2.4.

5.3 Durability requirements

5.3.1 Durability of latch action

When tested in accordance with 7.2.1 the latch action shall complete the minimum number of 200,000 cycles with a load of 25 N applied. The latch action shall function correctly after this test fulfilling the requirements 5.2.4 and 5.4.2.

5.3.2 Durability of locking action

When tested in accordance with 7.2.2 the locking point mechanism (and if applicable anti-separation point) shall complete the minimum number of cycles in accordance with Table 2. The locking point mechanism shall function correctly after this test, fulfilling the requirements 5.2.4.

5.3.3 Durability of locking snib mechanism

When tested in accordance with 7.2.3 the locking snib shall complete the minimum number of cycles specified in Table 2. The function shall operate after the test.

5.3.4 Durability of clenching

When tested in accordance with 7.2.4 the clenching shall complete the minimum number of cycles in accordance with Table 2 with a force on the two extreme clenching points of 25 N. The lock shall operate after the test within the specified maximum operating torque.

Table 2 Durability requirements

Latch Action	Shared Latch Action		Locking points(s), anti-separation point(s) and/or clenching point(s) manually locking	Locking point(s), anti-separation point(s) and/or clenching point(s), automatically Locking	Snib Mechanism
	Key	Handle			
200 000	50 000	150 000	50 000	200 000	25 000

5.4 Door mass and closing force

5.4.1 Door mass

The dimensions and mass of the test door that shall be used are described in clause 4.2.3 and 6.1.3

5.4.2 Door closing force

When tested in accordance with 7.3.2 a closing force of 25 N shall be sufficient to enable the latch bolt to correctly engage the locking plate every time.

5.5 Corrosion resistance and temperature

5.5.1 Corrosion resistance

When tested in accordance with 7.4.1 the torques on the key, or follower, to operate the locking point(s) or anti-separation or clenching function or latch bolt(s) shall not exceed those specified in 5.2.4 by more than 20%.

NOTE For the purpose of this PAS, the ability to operate after the test is the only criterion; appearance is irrelevant.

5.5.2 Operation at extremes of temperature

When tested in accordance with 7.4.2 the torque to operate the locking point(s) and/or anti-separation function and/or clenching function and/or latch bolt shall not exceed requirements in clause 5.2.4 as appropriate, by more than 20% (-25/+70 °C)

5.6 Security of locking points

5.6.1 General security requirements

The lock and keep plates shall meet the requirements identified in Table 3.

Table 3 Security Requirements

Requirement	Value	Unit
Side load on locking point	7	kN
Net drilling time at each locking point for side load test	3	Minutes
Total drilling time at each locking point for side load test	5	Minutes
Minimum deadbolt projection	20	mm
Minimum resulting projection after load applied	17	mm
Net drilling time at each locking point for end load test	3	Minutes
total drilling time at each locking point for end load test	5	Minutes
Resistance to end load without boxed locking plates	5	kN
Resistance to end load with boxed locking plate	2	kN
Minimum resulting projection after load applied	19	mm
Resistance to side load on locking plate	7	kN

5.6.2 Requirements for side load

To determine resistance to drilling and side load on locking points and anti separation points, when tested in accordance with 7.5.2 each locking points shall be subjected to drilling for the specified time, and afterwards each shall resist a side load of 7k N when tested in accordance with Figure 1. For this test, performance criteria B shall apply.

Figure 1 Typical load test rig

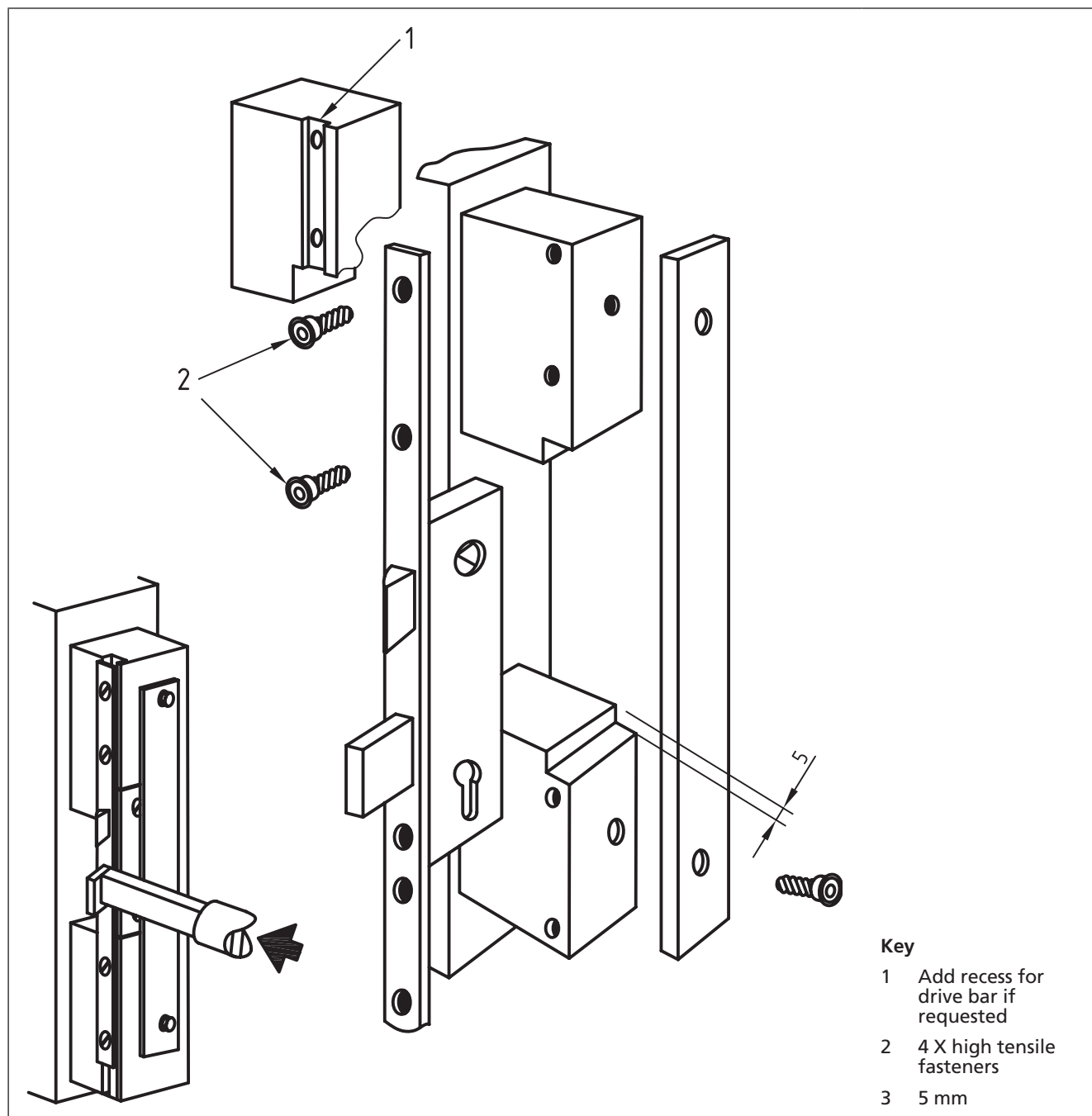

5.6.3 Locking point bolt projection

When measured in accordance with 7.5.3, the locking mechanism (bolt, hook or other) at each locking point when fully thrown in the locking direction and detained, shall have a minimum projection of 20 mm measured from the facebar.

5.6.4 Requirements for end load

To determine resistance to end load after drilling on locking point, when tested in accordance with 7.5.4 the locking assembly shall resist the end load of 5 kN applied as specified in 7.5.4.6 after drilling. At no time during or after the test shall the locking point projection be less than 17.0 mm.

Performance criteria B shall apply.

Where the locking point is protected by a box locking plate, the end load shall be a minimum of 2 kN.

5.6.5 Security requirements of the locking plate

5.6.5.1 When tested in accordance with 7.5.5.1, the box protected locking plate shall resist a load of 5 kN, when held for 60 seconds in X-, Y-, and Z- direction and shall not be deflected more than 3 mm in X and Y directions and the resulting internal depth in the X direction shall not be less than 19.0 mm.

After the test the box shall remain fixed to the locking plate.

The product shall remain fully functional both during and after the test.

NOTE This requirement can be waived if the associated lock deadbolt/anti-separation device resists the 5kN endload/disengaging load or the box does not have a security purpose (e.g. adjustment or decorative boxes).

5.6.5.2 To determine resistance to side load on locking plate, when tested in accordance with 7.5.6 each locking point shall resist a side load of 7 kN. Performance criteria B shall apply.

5.6.6 Protection against removal from the door

Resistance to removal from door shall be determined by testing in accordance with 7.7 to establish that those parts which contribute to its attack resistance cannot be removed:

- a) from the outside of the door when door is closed and locked;
- b) other than for locking assemblies with keyless egress, from the inside of the door when door is closed and locked, except by special tools.

5.7 Key operation and locking

5.7.1 Deadlocking

5.7.1.1 When manual locking is tested in accordance with 7.8.2.1 it shall not be possible to remove the key from the lock unless the locking point is in its unlocked or fully thrown and deadlocked position.

5.7.1.2 To test manual handle operation with separate deadlocking by key, if the locking points are not fully thrown it shall not be possible to turn and withdraw the key except when the locking points are in their fully withdrawn position.

5.7.1.3 When a lock with automatically locking points is tested in accordance with **7.8.2.3**, it shall conform to the following requirements:

- a) the locking points shall engage automatically, when the distance between facebar and locking plate is less than 5 mm;
- b) when releasing the locking points of a lock by key or handle operation, the bolt of each locking point shall reach its held back position before the door can be opened when the distance between facebar and locking plate is less than 5 mm;
- c) it shall not be possible to release the dead locking function by manipulation of the elements which are accessible between the facebar and the locking plate when the door is closed.

5.7.2 Differs

5.7.2.1 When tested in accordance with **7.9.2** locks shall have the minimum of 1 000 effective differs.

5.7.2.2 When tested in accordance with **7.9.3** keys shall have a minimum of 3 different step heights.

5.7.2.3 When tested in accordance with **7.9.4** it shall not be possible to open the lock with the closest key up and down (as defined by the manufacturer's coding system).

5.7.3 Key identification requirements of lever locks

When examined under the conditions specified in **7.9.1** a minimum of five detaining elements that form part of the lock mechanism (or latch action where there is direct operation by the key) shall be visible.

5.7.4 Coding protection

Keys shall not be marked with details of the locking assembly coding (**7.9.5**).

5.8 Anti-separation requirements

5.8.1 General

When the anti-separation point also functions as a locking point it shall also fulfil the requirements of locking points.

5.8.2 Resistance to drilling and pulling of anti-separation device

When tested in accordance with **7.10.1** the locking assembly shall be subjected to a total drilling time of: 5 minutes, not more than three minutes of which shall be applied to any one anti-separation point, after which each anti-separation point shall resist a pull force of 7 kN. Performance criteria B shall apply.

5.8.3 Resistance to drilling and disengaging force on anti-separation device

When tested in accordance with **7.10.2** the product shall be subjected to a total drilling time of 5 min, not more than 3 minutes of which shall be applied to any one anti-separation point, after which the

test device shall not force the anti-separation point to open with a disengaging force of 5 kN

Performance criteria B shall apply.

5.8.4 Resistance to pulling on locking plate for the anti-separation device

When tested in accordance with 7.10.3 the locking plate shall resist a pull load of 7 kN.

Performance criteria B shall apply.

5.8.5 Resistance to lifting of locking plate for the anti-separation device

When tested in accordance with 7.10.4 the locking plate shall resist an upward force of 7 kN.

Performance criteria B shall apply.

5.9 Clenching

5.9.1 General

The purpose of this test is to determine the maximum torque on the lock handle spindle and the key operation when the door seal pressure is fully applied (clenching).

Under this clause performance for the clenching points are described. The clenching point consists of a bolt and clenching plate that forces the door to its frame. For those clenching points that have anti-separation function they shall also be graded as described in 5.8. If the clenching point also has locking performance it shall be graded as in 5.6.

5.9.2 Determination of maximum torque on lock handle spindle and key operation

When tested in accordance with 7.2.4 (Figure 2) the 25 N clenching force shall be applied on each of the two (if applicable) extreme clenching points.

6 Test conditions

6.1 General

6.1.1 Testing status

Locks shall be tested with the locking plates supplied as intended for sale into the market.

6.1.2 Tolerances

Throughout this Standard the following tolerances shall apply, unless otherwise stated:

Mass (kilogram or gram) \pm 2%

Length (millimetres) \pm 2%

Force (Newton) $\pm 2\%$

Torque (Newton metre) $\pm 2\%$

Time (seconds) $\pm 5\%$

Temperature (degrees Celsius) $\pm 2\text{ }^{\circ}\text{C}$

Unless otherwise stated, forces shall be applied and raised to the required level within 1 min \pm 10 seconds and shall be held there for 1 minute + 5 s.

Figure 2 Example clenching side seal load

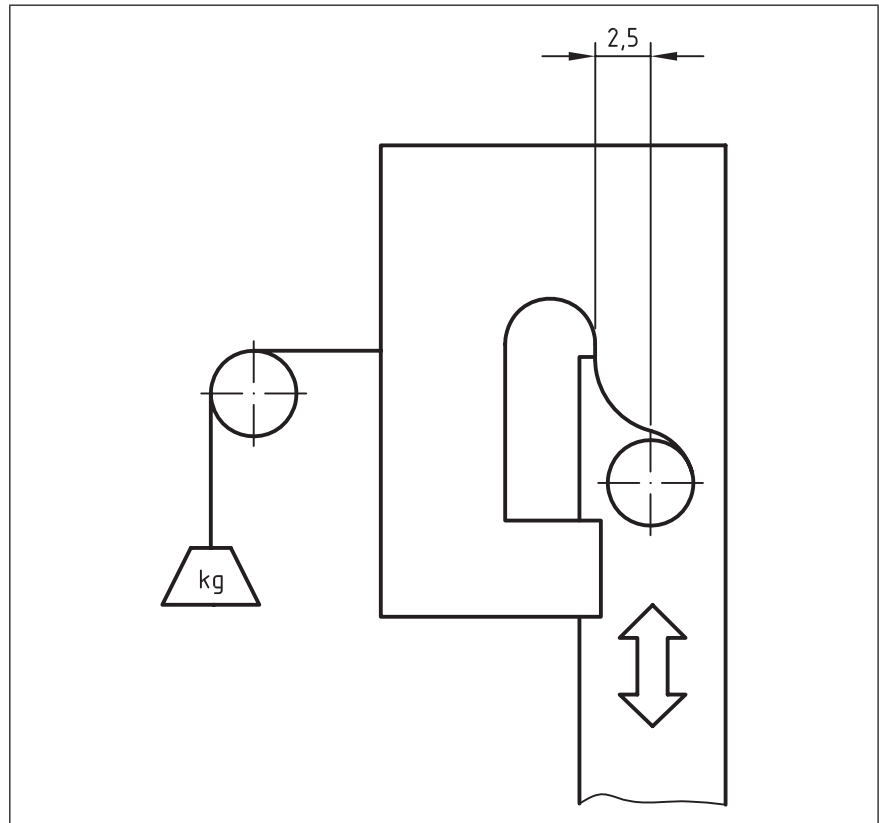

6.1.3 Mounting of the sample for testing

6.1.3.1 The sample locking assembly to be tested shall be installed in a test door purpose built to the requirements of 6.1.3.2 The test door shall be made to accept the test lock as supplied for durability testing, in its entirety. If the Test Door is to be used to perform strength testing (security/anti-separation/clenching) each locking point shall be mounted in an unsupported test rig. See example mounting in **Figure 3 and Figure 6** and Test Door (**Figure 4**).

6.1.3.2 The test door shall be constructed in steel or an alternative material of similar rigidity. The dimensions of the test door shall be such that the mass and the test forces specified in this PAS, can be applied safely (see note to this clause) and hinge points shall be incorporated in a manner that enables the specified durability tests to be carried out reliably.

NOTE An appropriate size and configuration would be a door 2100 mm high by 1100 mm wide, with rigidity such that any distortion perpendicular to the plane of the test door, taking place during the test

sequence, will be not more than 5 mm at any position. The centre of gravity of such a door should be at the centre of the door leaf.

6.1.3.3 The test sample shall be installed in the test door/rig using fasteners as strong as those specified in the manufacturer's instructions. If this is not possible, the fasteners used shall be machine screws to BS 4168. Where keep plates are supplied, the plates shall be mounted as specified in the manufacturer's instructions.

Figure 3 Typical load test rig

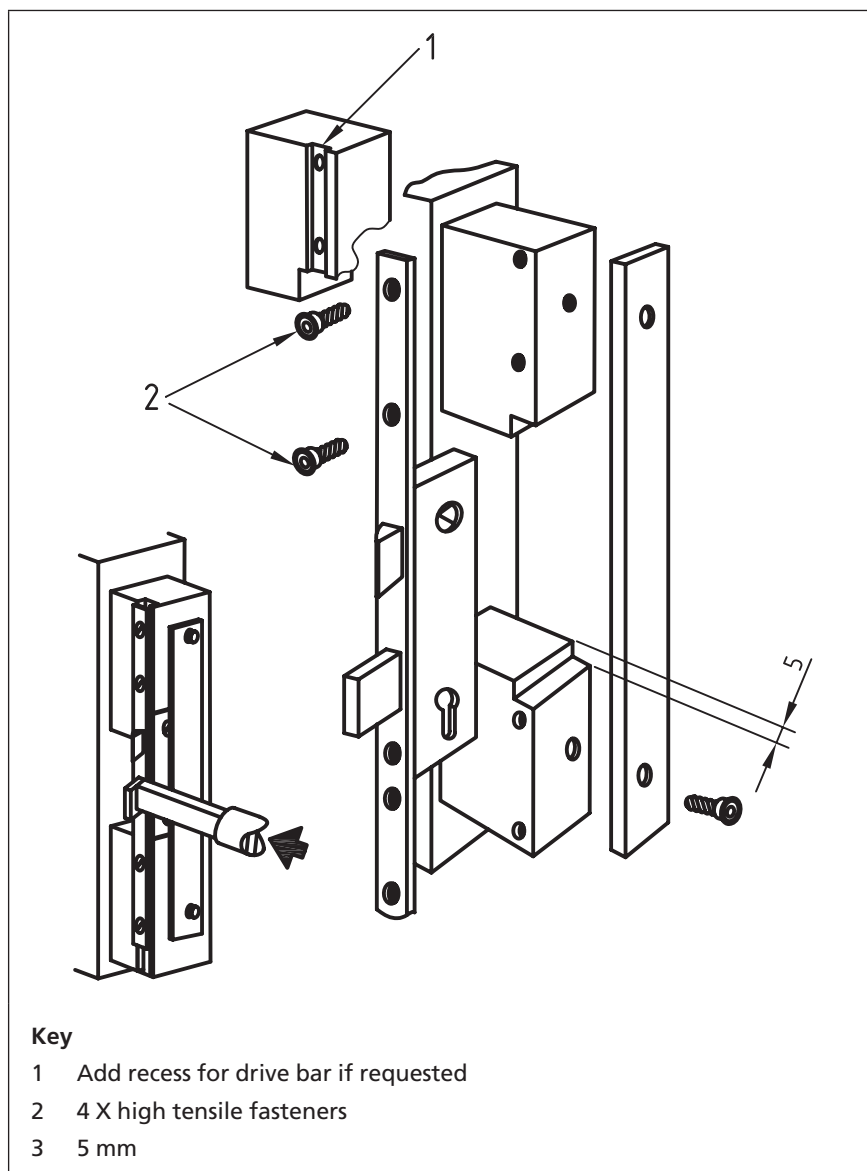

6.1.4 Number of samples to be tested

The number of samples required for type testing to this PAS, and the test sequences, shall be as shown in Annex C.

6.1.5 Sample maintenance

The sample shall be maintained during test if specified in the manufacturer's instructions, otherwise, the components may be cleaned and lubricated without dismantling the lock at the start of the test and after each 5000 cycles.

Figure 4 Example configuration for Test Door

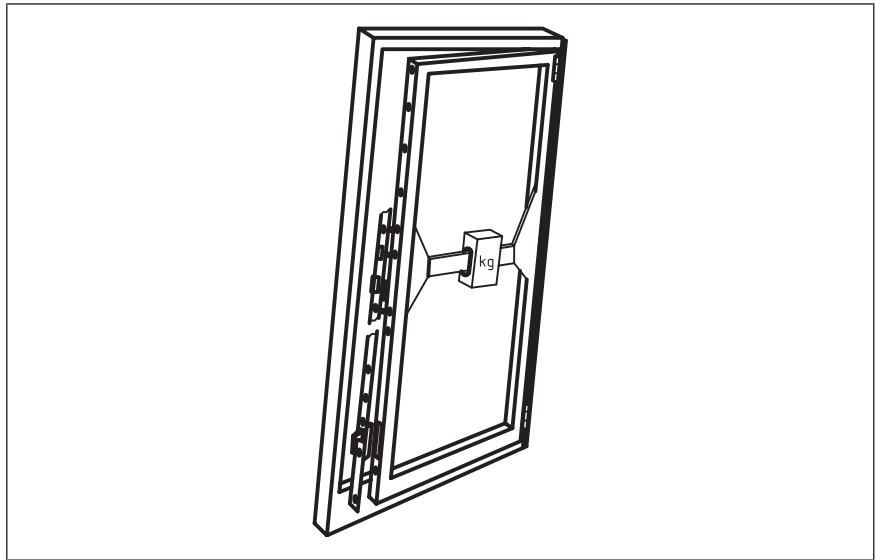

6.2 Performance criteria

6.2.1 Performance criteria "A"

During the application and holding time of a force or torque, the product and/or its components shall be allowed to deflect to an extent consistent with local tolerances/clearances, without any plastic deformation outside the tolerances taking place. The product shall remain fully functional both during and after the test.

6.2.2 Performance criteria "B"

During the application and holding time of a force or torque, the product and/or its components shall be allowed to deflect an amount consistent with local tolerances/clearances, but with some plastic deformation taking place providing that the security function is not significantly compromised, either during or after the test. The product does not need to be operable after the test. All products shall be tested in accordance with the manufacturer's instructions for use.

6.2.3 Performance criteria "C"

During the application and holding of a force or torque, the product and/or its components shall be allowed to deflect an amount consistent with local tolerances/clearances, but with some plastic deformation taking place, providing that the security function is not significantly compromised, either during or after the test. Additionally, it shall not be possible to manipulate the locked bolt to an unlocked position, during or after the test, using any tool other than the correct key with a maximum torque of 5 Nm. The product does not need to be operable after the test.

7 Test methods

7.1 Mechanical operation

7.1.1 Strength of bolt action

7.1.1.1 Install the test sample in a suitable test apparatus with means for preventing each bolt from moving more than 3 mm \pm 1 mm from its withdrawn position.

7.1.1.2 To test locking and clenching action apply a torque of 30 Nm, without shock, to the follower in the bolt throwing direction, applying the torque over a period of 5 \pm 2 s (5.2.4).

7.1.1.3 To test latch bolt action apply a torque of 20 Nm, without shock, to the follower in the bolt withdrawing direction, applying the torque over a period of 5 \pm 2 s.

7.1.1.4 To test minimum restoring torque, using a suitable torque gauge and adapter(s), fully withdraw the latch bolt via the follower before releasing the latch bolt and allowing it to return under its own spring force (where applicable) until the follower is within 5° of its back stop position.

7.1.2 Return force of latch bolt

7.1.2.1 Install the test sample in a vice or similar device, with the face plate vertical.

7.1.2.2 Using a suitable force gauge operating in the same plane of movement as the latch bolt, push each latch bolt fully in with the force gauge before allowing it to withdraw until the leading edge of the bolt head is 2 mm \pm 0.5 mm from the face of the facebar: Read off the return force on the latch bolt, from the force gauge (5.2.2).

7.1.3 Resistance to side load on latch bolt(s)

7.1.3.1 Install the test sample so as to replicate fitting for actual use, as illustrated in **Figure 5** using metal thread screws of equivalent or greater strength to the fixing means supplied/recommended by the manufacturer.

7.1.3.2 Using a tool as illustrated in figure 4b, apply a force of 3 kN to the securing face of each latch bolt at a point 3 mm (\pm 0,2 mm) from the face plate (5.2.3).

7.1.4 Lock operation torques

7.1.4.1 To test the withdrawal of latch bolts, Install the test sample in a vice or similar device with the face plate vertical.

7.1.4.2 Using a torque gauge with suitable adaptors, withdraw latch bolt(s) (or operate the locking or anti-separation point(s)) until each bolt head is fully retracted.

7.1.4.3 Record the torque required to effect the withdrawal of the latch bolt via the key or the follower.

Figure 5 Typical load test rig (5a) with detail of application tool (5b)

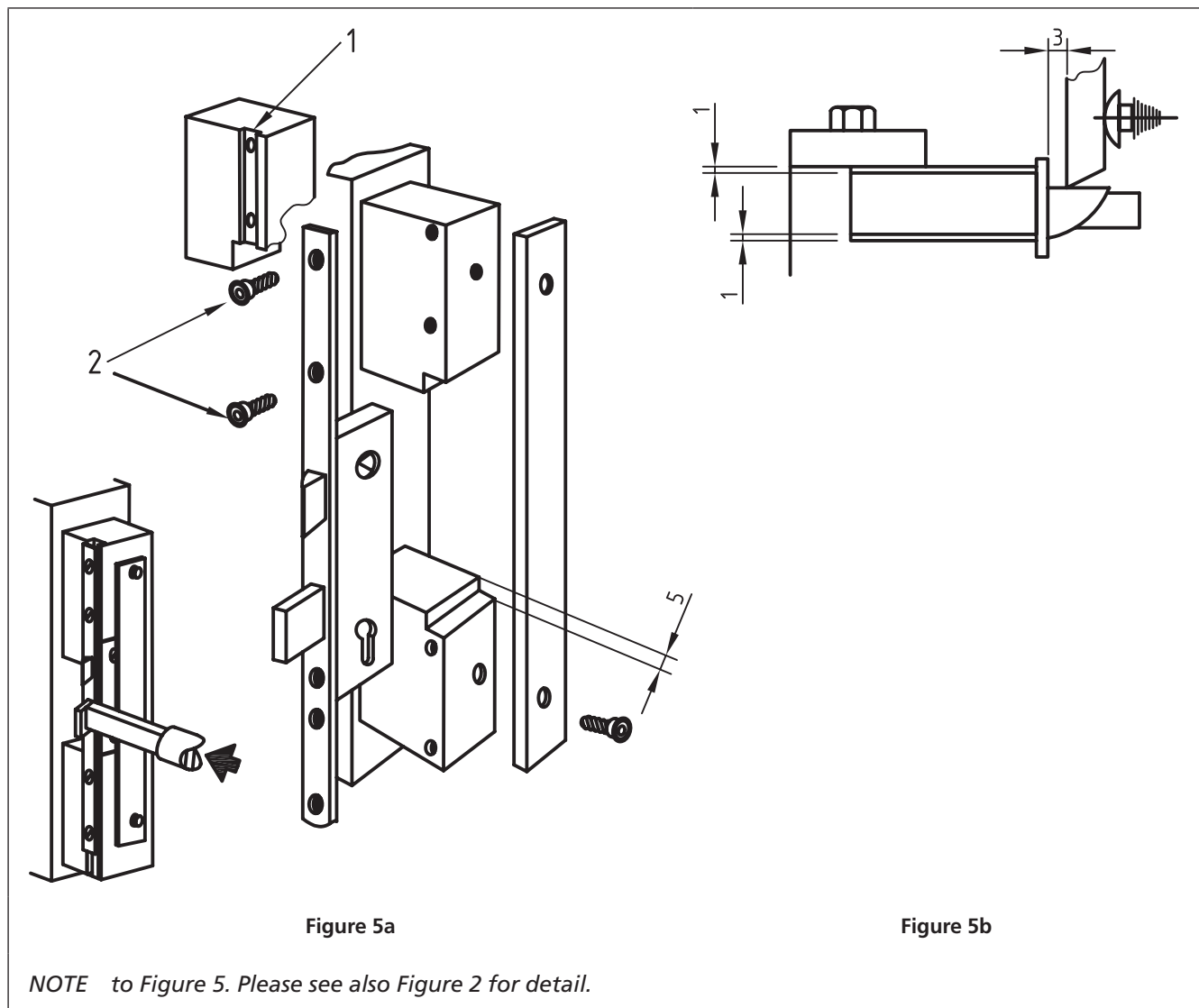

7.1.5 Strength of follower stops

7.1.5.1 Securely grip the lock in a vice, or similar fixture, then apply a torque of 40 Nm without shock to the follower, in both clockwise and anticlockwise directions; the torque shall be applied gradually in a time of 5s +/- 2 s.

7.1.5.2 Record the torque applied to the follower and check the functioning of the lock (5.2.4).

7.1.6 Torque resistance of lockable follower

Install the lock in accordance with 6.1.2 and apply a torque of 60 Nm without shock, to the locked handle/ follower.

7.2 Durability tests

7.2.1 Durability of latch action with force applied

7.2.1.1 Install the lock or latch and its correct locking plate on a test door and frame in accordance with 6.1.3 with a gap of 3 +/- 1 mm,

together with a representative set of lever handle furniture as shown in Figure 6. There shall be provision for applying a side load of 25 N, as shown in Figure 6 and Figure 7.

Figure 6 Section through test door

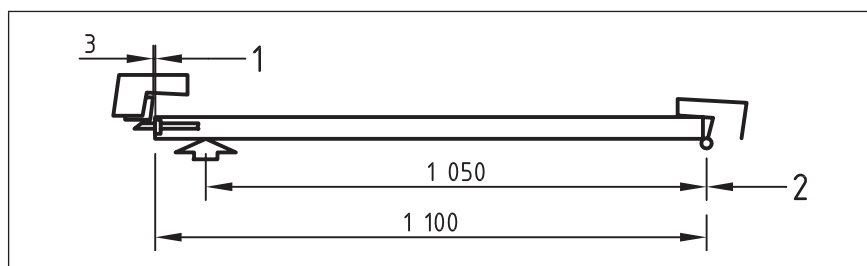
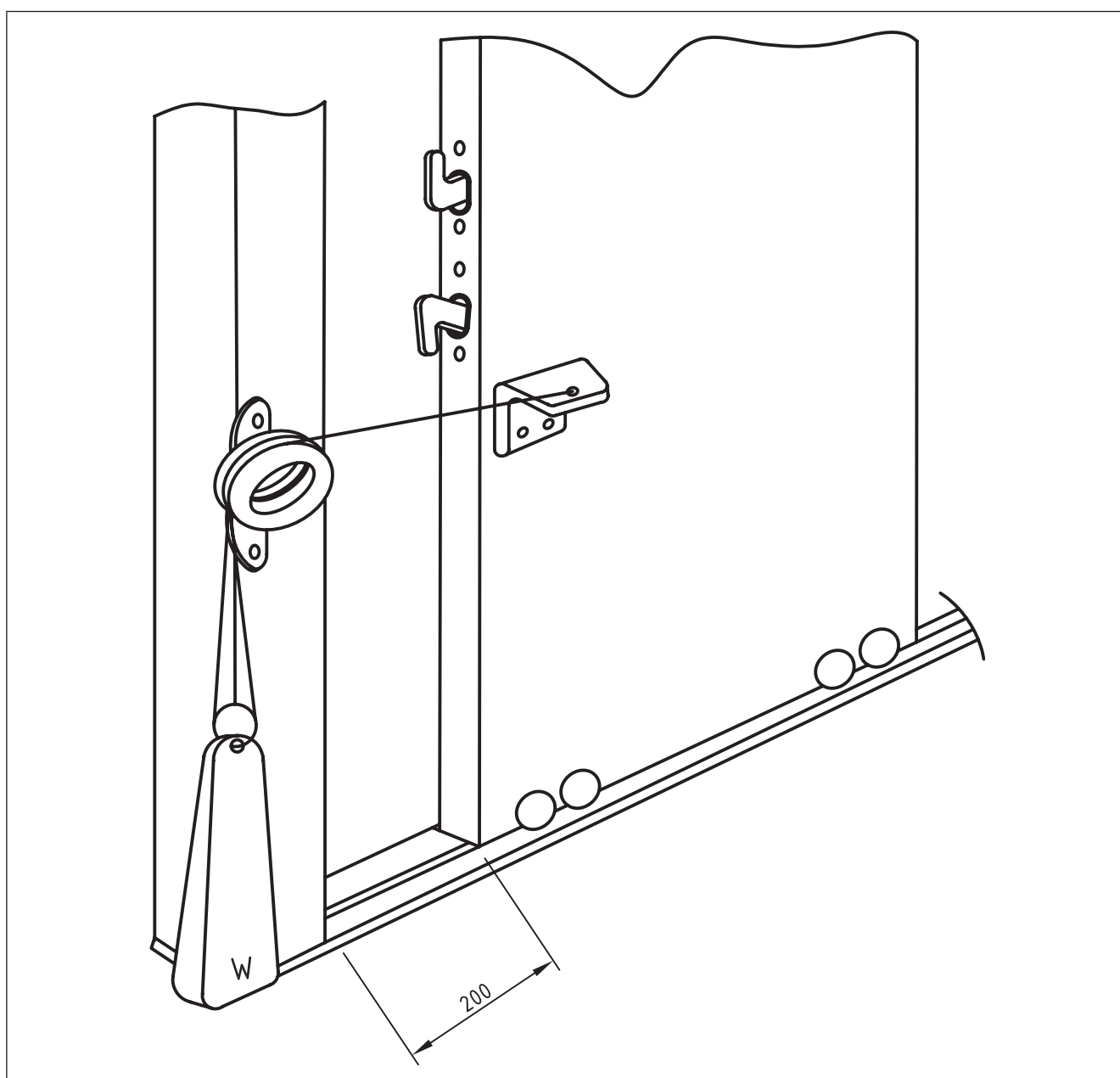

Figure 7 Typical sliding door test rig



7.2.1.2 If the latch is reversible, reverse it twice before testing. Submit the latch to 200,000 cycles by handle or 150,000 cycles via the handle and 50,000 cycles by key for a shared latch action, at a maximum rate of 10 cycles per minute, as follows:

- i) apply a force of 25 N to the test door, in the opening direction;
- ii) rotate lever handle or key to fully withdraw latch bolt with a maximum torque of 7 Nm by handle and 1.0 Nm by key;
- iii) open door a distance of 200 mm +/- 5 mm;
- iv) allow handle to return or bring the key to the 'at rest' position;
- v) remove force of 25 N;
- vi) allow door to close under influence of 25 N closing force, causing the latch bolt to strike and fully engage in the locking plate.

7.2.2 Durability of locking action

7.2.2.1 Install the test piece in the test door as shown in **Figure 4**, with its face plate vertical and with the test apparatus configured so as to permit key rotation, and of insertion and withdrawal of the key from the lock.

7.2.2.2 Insert the key from the outward facing side of the lock or where the outward face is not determinable, from either side.

7.2.2.3 Submit the lock to the number of complete test cycle specified below and at a maximum rate of 15 cycles per minute. Each cycle should be not less than 2 s.

- i) insert key in lock;
- ii) rotate key sufficiently to fully engage deadlocking function, and where applicable, throw and detain bolts and /or anti-separation devices;
- iii) remove key from lock;
- iv) re-insert key into lock to fully disengage deadlocking function, and where applicable, withdraw bolts and/or anti-separation devices;
- v) remove key from lock.

7.2.2.4 Where the locking points are in the form of automatically engaging bolts, use a modified test cycle as follows:

- i) insert key into lock;
- ii) rotate key sufficiently to fully withdraw bolts;
- iii) rotate key in reverse direction, allowing bolts to return to an 'at rest' position;
- iv) withdraw key from lock.

7.2.2.5 If the key operates both bolts and/or anti-separation devices and latch bolt action, the test cycle shall include the complete key throwing action.

7.2.2.6 In the withdrawn position, the key can remain in the keyway, provided that it is not in contact with the detaining elements (levers, pins, etc.).

7.2.2.7 Where the product is designed to be used in conjunction with a cylinder, configure the test to operate the cylinder key directly, but without the necessity to insert and withdraw the key.

7.2.2.8 For locks where bolts are operated by a lever handle and the key operation is needed only for the deadlocking function, conduct the durability test accordingly.

7.2.2.9 Observe and record whether or not the mechanism functions after completion of the test.

7.2.3 Durability of locking snib mechanism

7.2.3.1 Mount the test piece on a fixture providing either a sliding or partial rotary action depending upon the design of the snib mechanism.

7.2.3.2 Submit the latch to a test cycle consisting of moving the snib from an unlocked, to a locked position and back to an unlocked position for the number of complete test cycle specified in **5.3.3** at a rate of not more than 60 cycles per min.

7.2.3.3 Observe and record whether or not the snib functions after completion of the test.

7.2.4 Durability of clenching action

7.2.4.1 When performing the durability test for locking points with clenching action, install the test piece in a manner that permits the bolt(s) to be displaced laterally 2.5 mm by the locking plate(s) and the clenching force of 25 N at maximum displacement (measured perpendicular to the movement of the bolt(s) to be applied (**figure 2**).

7.2.4.2 If the clenching bolts are reversible, reverse them twice before testing.

7.2.4.3 Before commencing the durability cycle test, measure and record the operating force of the clenching and confirm that the maximum operating torque does not exceed the operating torques of **5.2.4**.

7.2.4.4 Submit the test piece to the durability test in **5.2.9**.

7.2.4.5 After the completion of the durability test, measure and record the torque required to operate the clenching action.

7.3 Door mass and closing force

7.3.1 Door mass

Load door mass of 100 kg on test door as recommended in **Figure 4**.

7.3.2 Door closing force

7.3.2.1 Install the lock or latch and its correct locking plate as defined by the manufacturer onto a test door and frame as shown in **Figure 8** ensuring that the distance between the lock and the locking plate is 3 mm +/- 1 mm.

7.3.2.2 Clean the latch and the locking plate before each test.

7.3.2.3 To test, open the test door such that the latch bolt is fully thrown and in contact with the locking plate before bringing it to close under influence of 25 N (see **4.2.3**). Repeat the test three times, with the latch bolt correctly engaging the locking plate each time.

7.3.2.4 After the completion of the test, record the result.

Figure 8 Application of side load for latch durability tests

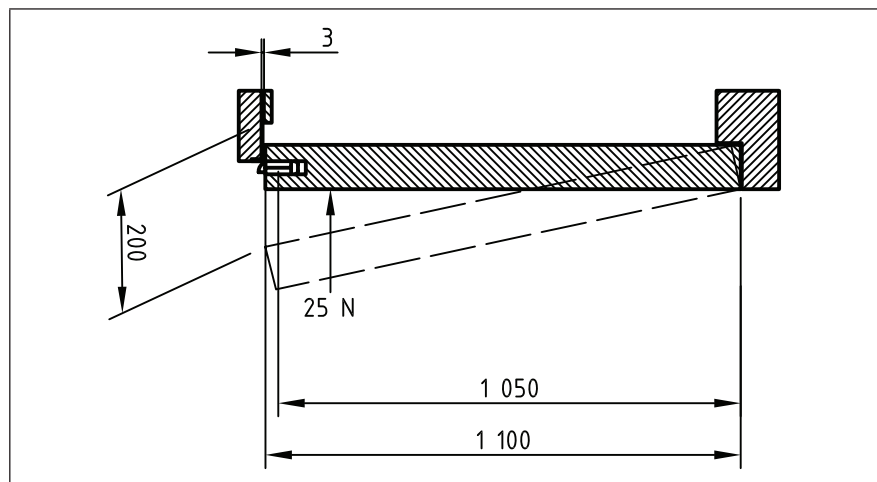

7.4 Corrosion resistance and temperature

7.4.1 Corrosion resistance

7.4.1.1 Install the lock in a fixture similar to a door application and subject to a neutral salt spray, as specified in clauses 5.1 and 5.6 of **BS EN 1670: 2007** (class 3 or class 4, as appropriate) for a period not exceeding 240 h.

7.4.1.2 During the test period, operate the lock once during each 24 hours.

7.4.1.3 Immediately following the neutral salt spray test, clean the lock and test in accordance with 7.2 operating the lock or latch, 20 times.

7.4.1.4 Measure and record the force required to open the lock during the final three opening operations.

NOTE This test can be scaled (e.g. using a sales sample).

7.4.2 Operation at extremes of temperature

7.4.2.1 Stabilize the lock before the test by subjecting it to constant temperature of 20 ± 5 °C and a relative humidity of 60 ± 5 % for a period of at least 1 h. Keep the key separately at normal room temperature during the tests.

7.4.2.2 Heat the locks at the minimum rate of 10 degrees ± 10 % per hour until the required temperature of $+70$ °C is reached and allow to dwell at this temperature for a minimum of 2 h.

7.4.2.3 During the final 20m of this dwell time, operate and check each lock as described below:

- i) using its correct key to fully withdraw and where applicable to throw the bolts, anti-separation and/ or clenching points measure and record the torque required and compare with the value provided in 5.2.4
- ii) using its follower to operate the latch bolt, ensuring that it is fully withdrawn and check and record whether or not the latch bolt still extends to its fully thrown position
- iii) where applicable, manually operate any anti-thrust slide and check and record whether or not the anti-thrust slide is still free to operate.

7.4.2.4 Cool the locks at the minimum rate of 10 degrees +/- 10% per hour until the required temperature of -25°C is reached and allow to dwell at this temperature for a minimum of 2 h. During the final 20 m of this dwell time, repeat the checks given in 7.4.2.3.

NOTE This test can be scaled (e.g. using a sales sample).

7.5 Security tests

7.5.1 Torque resistance of lockable follower

7.5.1.1 Install the lock on a fixture and by means of a suitable adapter apply a torque of 150 Nm to the locked follower, in both directions.

7.5.1.2 Check and record whether or not the lock was forced open.

7.5.2 Requirement for side load

7.5.2.1 To determine resistance to drilling and side load, install the test piece in a test apparatus, in the manner shown in **Figure 9** using a tool or the correct locking plates provided with the lock. Where the application allows, locks shall be mounted to allow testing from both sides.

Figure 9 Typical load test rig (9a) with detail showing application of tool (9b).

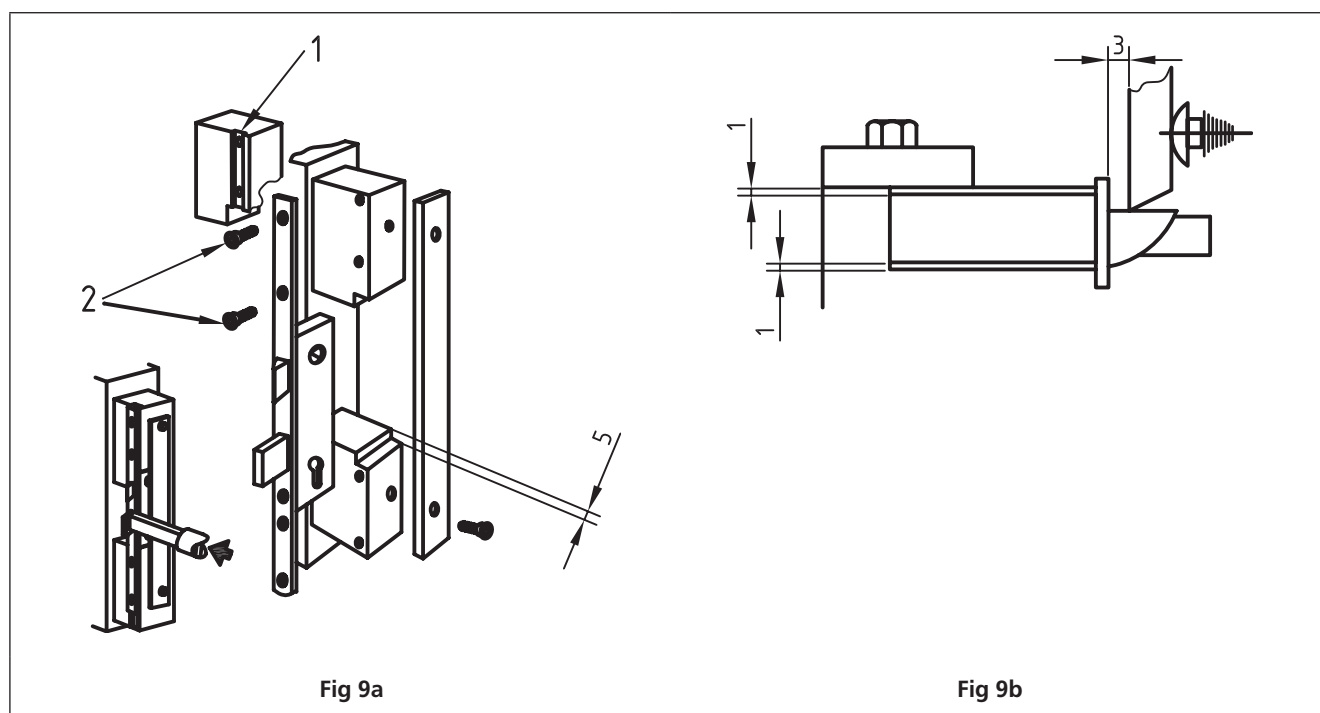

7.5.2.2 Test equipment: drilling machine (power not less than 500 W and not more than 700 W and speed of not less than 500 rpm and not more than 800 rpm.) fitted with a high speed steel drill of maximum diameter 5mm, to ISO 10899 or equivalent (**Figure 10**).

7.5.2.3 Drill continuously on each locking point, applying a force of 300+/- 25 N axially to the drill, for a maximum drilling time of three minutes. Coolant or lubrication may not be applied to the drill during the test.

Figure 10 Typical drilling apparatus

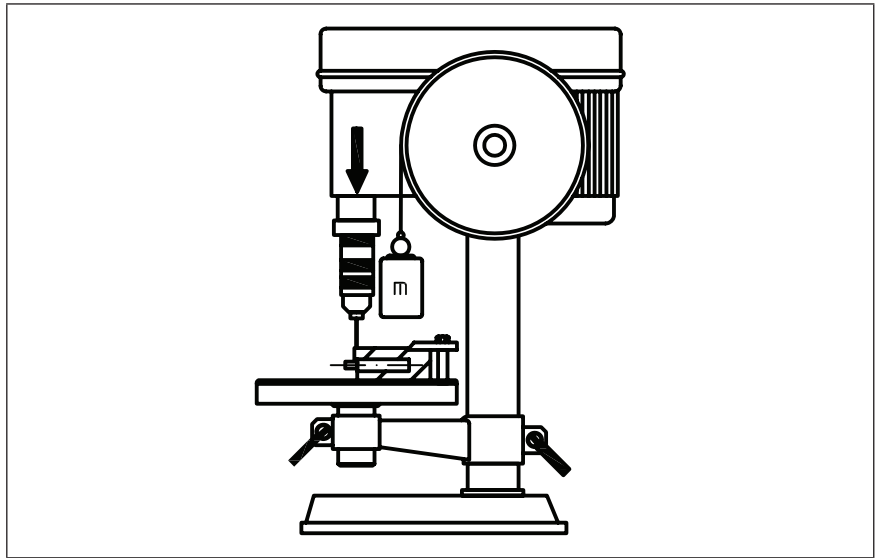

7.5.2.4 Drill away as much as possible of the exposed bolt adjacent to the face plate, in the time allowed.

7.5.2.5 Apply a side load of 7 kN to each locking point in turn, either by using a tool in accordance with **Figure 9** at a distance of 3 mm from the facebar or using the manufacturer's specified locking plate for a period of $60^{+10/-0}$ s.

NOTE There is no requirement for the lock to be operable after the test.

7.5.3 Locking point bolt projection

7.5.3.1 at each locking point, throw the bolt to the fullest extent in the locking direction and detain.

7.5.3.2 perpendicular to the face plate, measure and record the length of unloaded bolt projecting at each locking point.

7.5.4 Requirements for end load on locking point

7.5.4.1 To determine resistance to drilling and end load, install the test lock in a 44 mm wooden block which in turn is mounted in a test apparatus for use with drilling machine.

7.5.4.2 Test equipment: drilling machine (power not less than 500 W and not more than 700 W and speed of not less than 500 rpm and not more than 800 rpm.) fitted with a high speed steel drill of maximum diameter 5mm, to ISO 10899 or equivalent.

7.5.4.3 Drill continuously on each locking point, applying a force of 300 ± 25 N axially to the drill, for a maximum drilling time of three minutes. Coolant or lubrication may not be applied to the drill during the test.

7.5.4.4 Drill away as much as possible of any vulnerable elements in the lock with the objective of enabling the deadbolt to be withdrawn.

7.5.4.5 Transfer the test piece to another test apparatus configured so as to permit the deflection of the deadbolt to be measured (**Figure 11**).

Figure 11 Typical load test jig

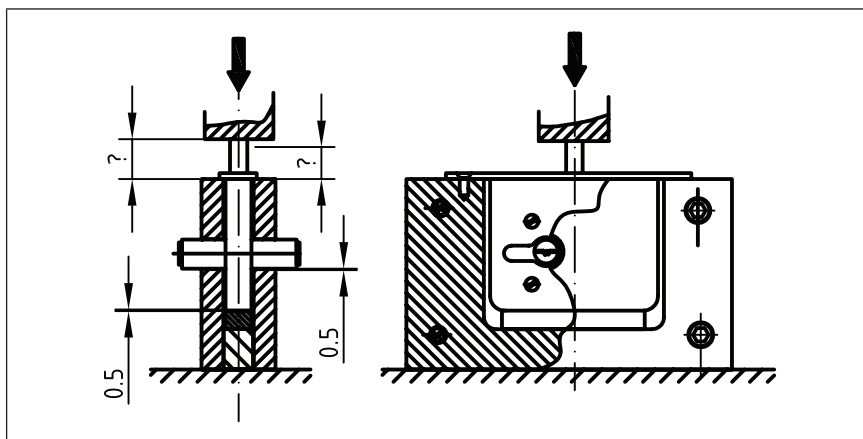

7.5.4.6 Apply end loads of: 5 kN to each locked deadbolt for a period of $60^{+10/-0}$ s.

7.5.4.7 Measure and record the extent of projecting deadbolt.

NOTE 1 It is not necessary for the lock to be operable by key after this test.

NOTE 2 Where deadbolts are protected by a box locking plate conforming to 5.8.5 the end load requirement need not exceed 2 kN.

NOTE 3 Where vulnerable elements are protected by furniture conforming to BS EN 1906, the drilling test can be omitted for that particular area. Such omissions shall be recorded in the test report.

7.5.5 Testing for security requirements of the locking plate

7.5.5.1 The locking plate shall be mounted in a test apparatus in which the internal depth can be measured as shown in figure 12 or as defined by the manufacturer and in which a 5 kN end load can be applied centrally to the surface of the box or where the deadbolt/anti-separation device works (if known), in three directions X, Y and Z for a period of 60 s^{0+10}

Initial internal depth in the X direction is recorded before applying the load.

The deflection under test is to be measured in the area where the deadbolt/anti-separation device is located.

Loading in Z direction is to test the fixing of the box (deflection not to be measured).

A 5 kN force is applied with a tool having a surface of 5 mm × 20 mm.

NOTE Separate locking plates for each tested direction.

7.5.6 Resistance to side load on locking plate

7.5.6.1 Install the locking plate in a test apparatus using metal thread screws of equivalent strength to the fixings supplied/recommended by the manufacturer or as specified by the manufacturer (5.9).

7.5.6.2 Apply a side load of 7 kN to each bolt aperture for a period of $60^{+10/-0}$ s, using a tool which simulates the bolt of an appropriate locking point.

7.5.6.3 Measure and record deformation or failure of the plate.

Figure 12 Typical arrangement for testing the security of the locking plate

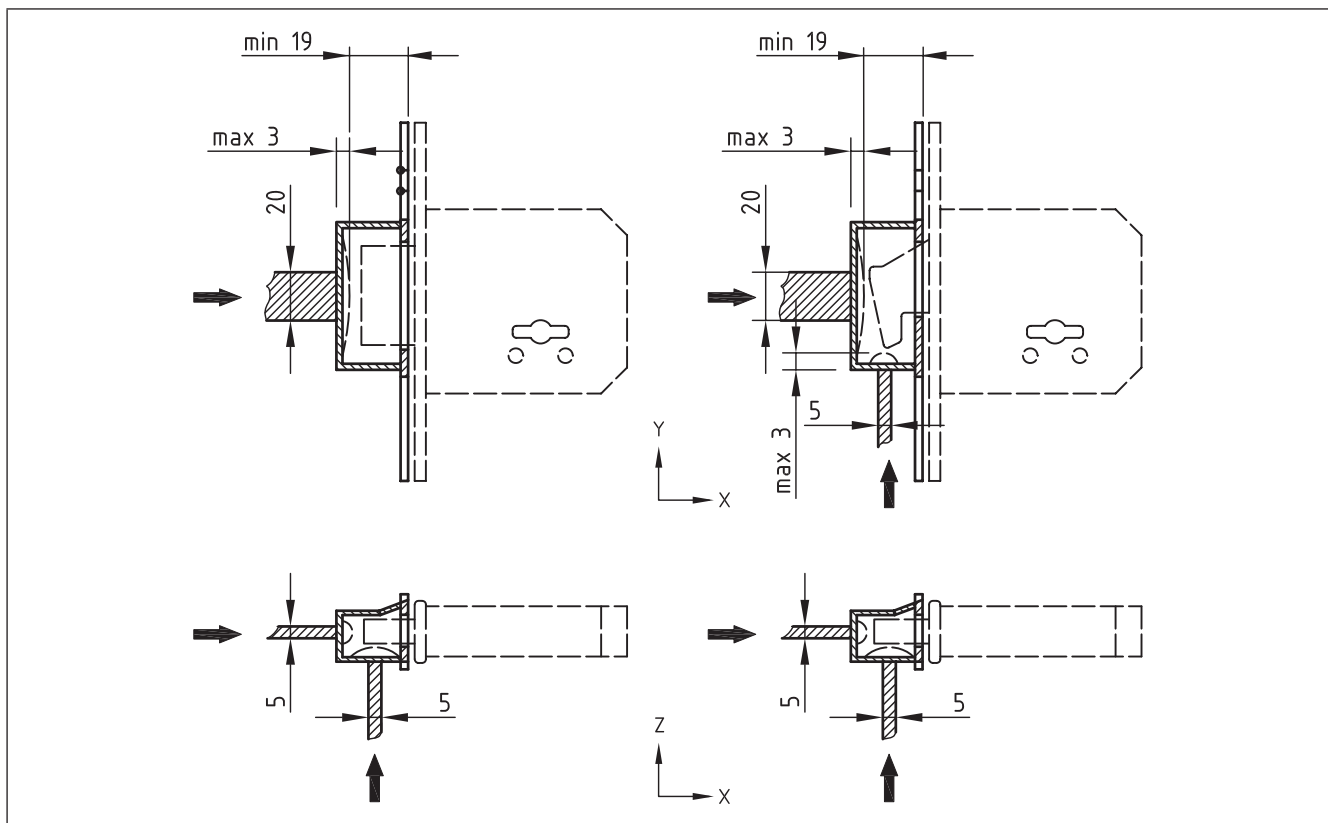

7.6 General vulnerability assessment

7.6.1 All locks

A thief resistant lock assembly shall be submitted for test in accordance with Annex A. In order to conform to the requirements of this standard, each lock assembly shall pass the panel's examination for general vulnerability.

7.6.2 Cylinders for locks (integral or separate)

Cylinders shall be submitted in accordance with Annex A. In order to conform to the requirements of this standard, each cylinder type shall pass the panel's examination for additional vulnerability for cylinders.

7.6.3 Lock assemblies incorporating a cylinder

7.6.3.1 Where a lock assembly incorporates a cylinder, its vulnerability to manual attack shall be tested in accordance with PAS 24:2007+A2:2011 with the following modifications.

- A test sample shall be either a new lock assembly or one that has been used as "Sample B and J" in BS EN 12209:2003, Table C.1.
- A test sample shall be mounted in a wooden block (in place of a test door), with a thickness that equates to the minimum door thickness for which the lock is intended to be used. It shall be mounted in such a way that it does not move by more than 5 mm in any direction during the test and that the lock forend is vertical. It shall be at a height of $(1\ 000 \pm 100)$ mm.

- c) The side on which any protective furniture is fitted shall be treated as the attack face.

7.6.3.2 Any protective furniture incorporated into the lock assembly shall be included as part of the test sample.

7.6.3.3 The lock shall have failed if it can be opened as a result of testing.

7.7 Protection against removal from door

7.7.1 From the outside with door closed

7.7.1.1 Install the lock and keep plates to the manufacturers instructions.

7.7.1.2 Inspect all fixings supplied for use with the lock under test to identify any that are accessible when the door is closed.

7.7.1.3 Record any fixings that are visible.

7.7.2 From the inside with door closed

7.7.2.1 With the lock and keep plates installed as for **7.7.1.1** and with the use of any of the tools listed in BS 3621:2007, attempt to remove any fixings that are exposed.

7.7.2.2 Record any fixings that proved to be removable under the conditions specified in **6.9.1.3**.

7.8 Type of key operation and locking

7.8.1 Strength of key

7.8.1.1 Install the lock in a test apparatus provided with the means of preventing the deadbolt from moving more than 3 mm +/- 1 mm from its withdrawn position.

7.8.1.2 Over a period of 5 +/- 2s progressively apply a torque of not more than 2.5 Nm, in the bolt throwing direction and without shock, to the correctly inserted key.

7.8.1.3 Measure and record any failure of the key construction.

NOTE This test is not applicable to cylinder keys in accordance with BS EN 1303.

7.8.2 Deadlocking

7.8.2.1 To test manual locking, install the lock in the Test Door in accordance with the Manufacturers instructions and operate the locking points from the fully unlocked to fully thrown and deadlocked position applying a live end load of 15 N on each locking point in turn.

NOTE The above test determines if the deadlocking feature is effective.

7.8.2.2 To test manual handle operation with separate deadlocking by key, with the lock installed as **7.8.2.1**.

- i) operate the locking points using the handle, from the fully unlocked to fully thrown and deadlocked position applying a live end load of 15 N to each locking point in turn.
- ii) Check and record whether or not it is possible to turn and withdraw the key in any intermediate positions.

7.8.2.3 To test automatically locking points, install the lock and its locking plate on the test door in accordance with the manufacturer's instruction ensuring a gap of 5 mm between faceplate and locking plate.

- i) With the test door open at 5°, apply a closing force of 50 N at right angles to the face of the test door, at a position of 1 000 mm from the centre line of the hinges of the test door and at between 800 mm and 1 200 mm from the bottom of the test door to re-engage the lock in the secured position.
- ii) Verify that the deadbolt has reached its fully thrown and deadlocked position.
- iii) At the manufacturer's specified 'point of maximum gap between the test door and the frame', attempt to manipulate the deadlocking function and record whether or not this is possible
- iv) Disengage the locking point by key or handle operation observe and record whether or not the bolt of each locking point has reached its held back/fully withdrawn, position before the door can be opened.

7.9 Key Identification requirements of lever locks

7.9.1 Detaining elements

Examine the key under ambient lighting conditions, wearing sight correction if usually worn.

7.9.2 Effective differs

Observe and record, whether or not the number of effective differs is in accordance with the manufacturer's differ charts and /or supporting documentation demonstrating the principle of calculation.

7.9.3 Differing step heights on key

Observe and record, whether or not the differing step heights on key the are in accordance with the manufacturer's differ charts and/or to supporting documentation demonstrating the principle of calculation.

7.9.4 Non-interpassing of keys with just one interval differ

7.9.4.1 The test shall be conducted after the durability test 5.3.2.

7.9.4.2 Attempt to operate the test lock with keys differing from the correct key by one interval up and down in any one step position.

7.9.4.3 Apply torque of 1,5 Nm, on the key bow and observe whether or not, inter passing occurs.

7.9.4.4 Observe and record whether or not inter-passing or operation occurs.

7.9.5 Coding protection

7.9.5.1 Check coding protection in accordance with 5.7.4, based on manufacturer's information.

7.9.5.2 Record whether or not the requirements of 5.7.4 have been met.

7.10 Test of anti-separation provision

7.10.1 Resistance to drilling and pulling of anti-separation device

7.10.1.1 Install the test piece in a suitable test apparatus for use with drilling machine as shown in **Figure 13**.

7.10.1.2 Test equipment: drilling machine (power not less than 500 W and not more than 700 W and speed of not less than 500 rpm and not more than 800 rpm) fitted with a high speed steel drill of maximum diameter 5mm, to ISO 10899 or equivalent.

7.10.1.3 Drill continuously on each locking point, applying a force of 300+/- 25 N axially to the drill, for a maximum drilling time of three minutes. Coolant or lubrication may not be applied to the drill during the test.

Figure 13 Typical test rig for anti-separation

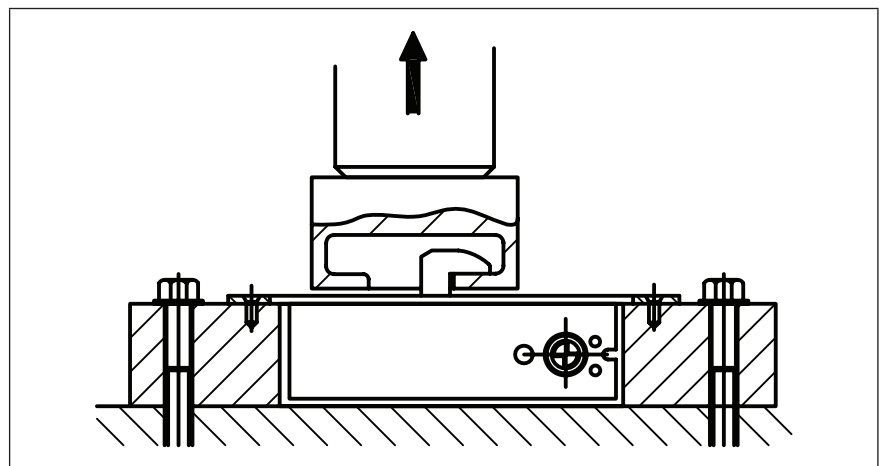

7.10.1.4 Drill away as much as possible of the anti-separation devices adjacent to the forend. The accumulated time for drilling all anti-separation points shall not exceed a total time five minutes (excluding time taken to change to the next anti-separation point).

7.10.1.5 Mount the product in a suitable fixture as shown in **Figure 13** using metal thread screws of equivalent strength to the fixing means supplied/recommended by the manufacturer, and the pull force of 7 kN applied to each anti-separation point and receiver plate in turn, for a period of 1 min + 10 s.

7.10.2 Resistance to drilling and disengaging force on anti-separation device

7.10.2.1 Mount the test piece in a suitable test apparatus for use with drilling machine as shown in **Figure 13**.

7.10.2.2 Test equipment: drilling machine (power not less than 500 W and not more than 700 W and speed of not less than 500 rpm and not more than 800 rpm) fitted with a high speed steel drill of maximum diameter 5mm, to ISO 10899 or equivalent.

7.10.2.3 Drill continuously on each locking point, applying a force of 300+/- 25 N axially to the drill, for a maximum drilling time of three minutes. Coolant or lubrication may not be applied to the drill during the test.

7.10.2.4 Transfer the test piece to another suitable fixture as shown in **Figure 14** using metal thread screws of equivalent strength to the fixing means supplied/recommended by the manufacturer and the disengaging force of 5 kN applied to each anti-separation point and receiver plate in turn, for a period of 1 min + 10 s.

Figure 14 Typical test jig for 'Disengaging Force' test

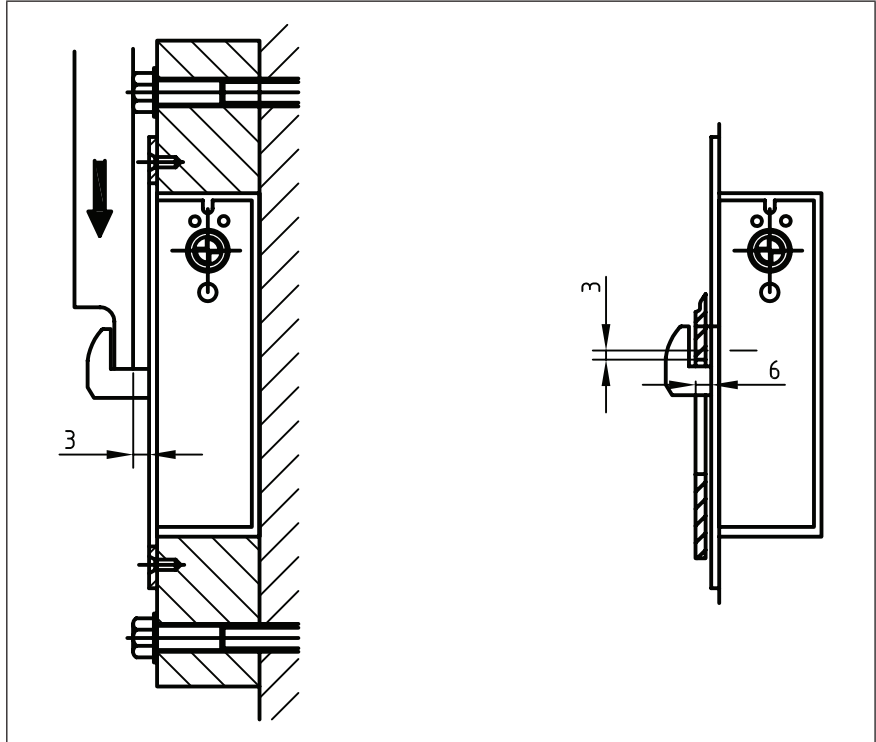

7.10.3 Resistance to pulling on locking plate for the anti-separation device

7.10.3.1 Mount the locking plate in a suitable test apparatus (example **figure 15**) using metal thread screws of equivalent strength to the fixings supplied/recommended by the manufacturer.

7.10.3.2 Apply a pull load of: 7 kN to the bolt aperture for a period of $60^{+10/-0}$ s, using a tool representing the anti-separation element of an appropriate lock.

7.10.3.3 Measure and record any distortion to the locking plate.

Figure 15 Typical test rig for pulling on locking plates

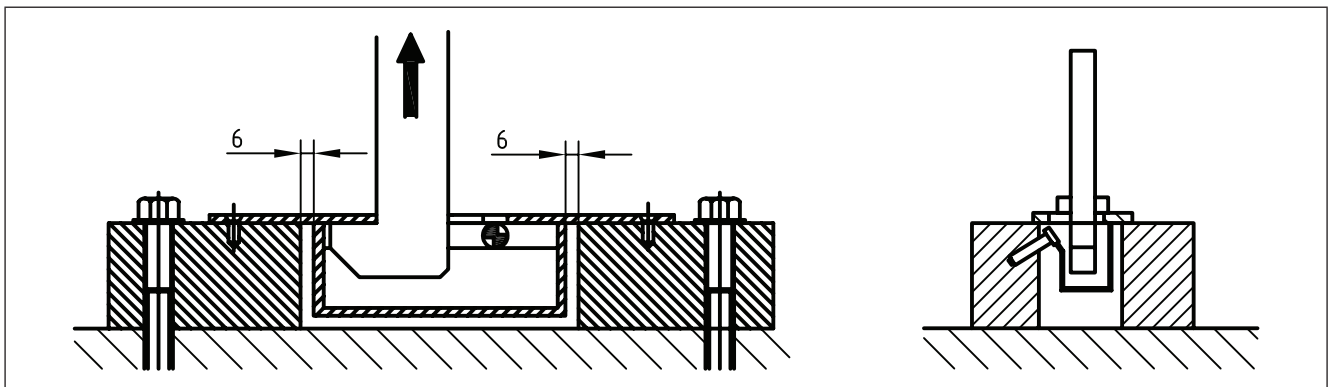

7.10.4 Resistance to lifting of locking plate for the anti-separation device

The locking plate shall be mounted in a metal fixture to a suitable test apparatus using machine screws of equivalent strength to the fixing screws supplied/ recommended by the manufacturer as shown in **Figure 16** and a lifting force of 7 kN is applied to the locating device aperture in the locking plate for a period of $60^{+10/-0}$ s, using a tool representing the locating device of an appropriate lock. If the locking plate has several apertures for locating devices, each of them is tested separately on separate samples. If the locking plate breaks or bends, so that the force cannot be reached or the loading tool slips away from the aperture, the force reached is recorded.

The product does not need to be operable after the test.

8 Marking

8.1 Packaging

The packaging for each multipoint locking assembly shall carry information presented in a manner that will be easily readable when the product is stocked on shelves, that includes:

- manufacturer's name, trademark or other means of positive identification
- clear identification of multipoint locking assembly enclosed
- the month and year of final assembly by the manufacturer
e.g. 0190 = January 1990
- number and date of this publicly available specification (PAS) i.e. PAS 3621: 2011

Figure 16 Typical test rig for lifting locking plates

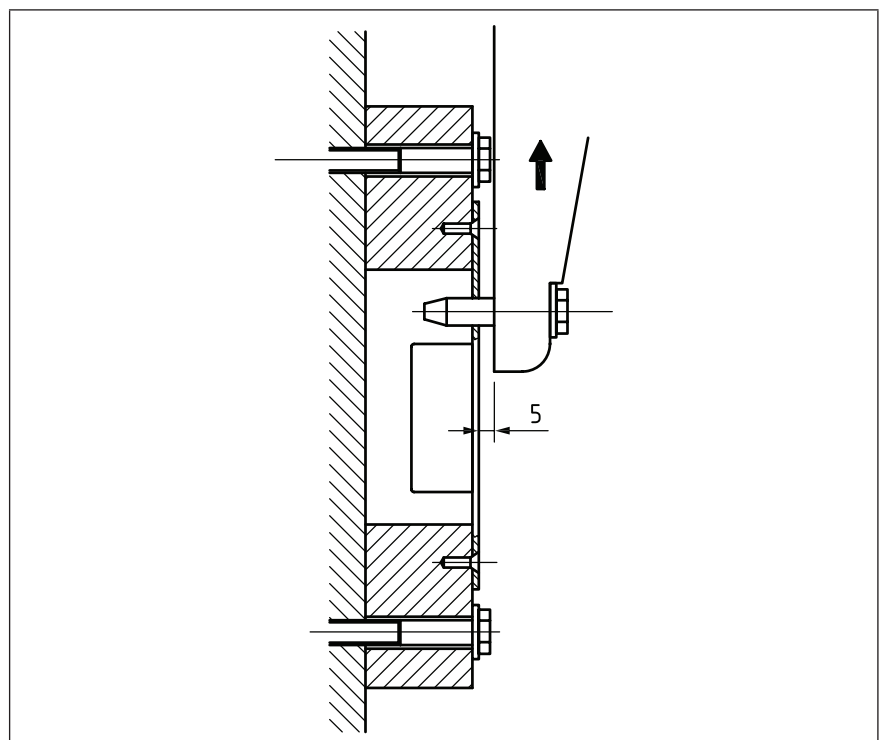

8.2 Product

A multipoint locking assembly for which conformance to this PAS is claimed, shall be marked with

- a) manufacturer's name, trademark or other means of positive identification
- b) number and date of this publicly available specification (PAS) i.e. PAS 3621: 2011

in a position where it will be clearly visible after the product has been installed.

*NOTE Requirement for provision of **installation instruction** is included in Clause 5.1.6 with reference to Annex B.*

8.3 Operating instructions

The Manufacturer shall provide clear instructions for operation of the multipoint lock in a form that can be left at the property in which each lock is installed.

NOTE It is recommended that such instructions be printed on a medium that is robust and reasonably durable and presented in a form that permits its being kept in proximity to the lock, For example, printed on card with a wipe clean surface in the form of a tag or label that could be suspended from or temporarily attached to the handle or key of a newly installed multipoint lock and that after removal, could be easily retained by the user in a safe, readily accessible location.

Annex A (normative) **General vulnerability assessment**

A.1 Principles of assessment

The assessment shall be undertaken by a panel of three expert assessors qualified in accordance with **A.8**. Each expert shall undertake an individual assessment and report back independently. In order for conformity to this British Standard to be claimed, each member of the panel shall report the test sample as having satisfactorily withstood the test, or where a suitable test key cannot be manufactured due to the design of the product, each expert shall confirm that the product is not vulnerable to the attack method described in this annex". The test is intended to assess the general vulnerability of a lock to an attack using knowledge, skill and professional ability. It is not intended to assess the lock's ability to resist attack involving significant force or by the use of tools only available to locksmiths.

Where an individual lock has more than one locking mechanism, all mechanisms accessible and operable from the outside face of the door shall be subject to assessment.

A.2 Submission of samples

A total of six complete lock/cylinder assemblies shall be submitted. These shall be representative of normal production and shall contain the most vulnerable combination of differs as determined by the panel. Two samples shall be supplied to each assessor, one for examination and one for assessment purposes. Where a range of products is assessed, the panel shall agree with the manufacturer which samples are required for assessment, and the decision shall be based on the examination of detailed drawings, specimens and discussions with the interested parties. If, during the assessment process an assessor identifies a particular vulnerability and believes that further tests are required, a maximum of two further samples shall be requested.

A.3 Preparation of the test sample

The test sample shall be mounted in accordance with the manufacturer's instructions in a wooden block or similar and the sample shall be verified as fully functional. For the majority of lock designs a block nominally 380 mm × 150 mm × 44 mm is suitable. Where the lock design is not compatible with this size block, the width and/or height may be increased with the agreement of the panel. The thickness of the block shall not be changed. During the test the lock shall be mounted in a rigid fixture at a working height similar to the intended location when installed in a door; nominally 1 000 mm from floor level.

A.4 Assessment procedure

NOTE Testing specified in BS EN 12209 and BS EN 1303 does not form part of this procedure.

Each assessor shall dismantle and examine the first sample prior to testing and assessing the second sample. There is no overall limit to the time required to dismantle and examine the first sample.

For the second sample, the overall duration of the assessment detailed in **A.5** shall not exceed 15 minutes and no one test technique shall be used for more than 3 minutes.

The maximum duration of the assessment detailed in **A.6** shall be 3 minutes, with a further 4 minutes allowed to conduct any modification deemed necessary in accordance with **A.6 iv**).

A technique is considered to be a combination of tools and location; any change in either shall constitute a new technique. All types of lock are deemed to have failed if it is possible for any of the assessors to withdraw the dead bolt such that its projection is less than 5 mm, or if any part of the lock can be removed from its mountings in such a manner that it would render a door insecure. A cylinder lock is deemed to have failed if it becomes possible to fully rotate the cam from the front face of the lock using the specified tools.

A.5 Assessment of all lock types (lever, cylinder, etc.)

- i) The assessors shall be familiar with the lock construction.
- ii) Using the tools specified in **A.7**, the assessors shall attempt to open the lock using manual dexterity and manipulative skills, rather than excessive force.

*NOTE Should the assessor believe that it is possible to open the lock using a tool that is not listed in **A7** but which is of similar availability and aggressiveness, this shall not, at that point, be recorded as a failure, but shall be reported to the BSI Project Manager responsible for this BSI PAS.*

- iii) Normally locks shall be assessed for resistance to attack from both sides. Locks that have an obvious "attack" side (e.g. rim night latches and mortise locks with protective furniture on one side only) shall be assessed from the attack side only.
- iv) The principal objective when assessing a range of locks is to identify the most vulnerable lock within the range. This may require more than one lock within a range to be assessed.

A.6 Additional procedure for the assessment of lock cylinders (integral or separate)

Cylinders used in a lock design shall additionally be assessed in accordance with the following procedure, for which a further time allowance is made (see **A.5**).

- i) Sample cylinders shall have combinations in which all step heights are in the mid-range, and are as close together as possible, but which also conform to manufacturer's specification and the requirements of EN 1303.
- ii) During assessment, cylinders shall be installed in a lock, which in turn shall be mounted as detailed in **A.3**.
- iii) The test key used for this assessment shall be machine cut by the manufacturer and shall comprise all bottom steps. A test key shall be rejected if the assessor does not consider it to be representative of a machine cut key, or is of the opinion that the steps are cut in such a way that it would reduce the likelihood of defeating the cylinder.
- iv) The length of the test key and its shoulder shall not be modified by the manufacturer; this may be done by the assessor.

- v) Where cylinders using a side bar code are supplied, the test key shall exhibit that side bar code
- vi) In the case of double sided cylinders, where one side only is intended for use on the outside of the door, only this side shall be subjected to test and the higher security side shall be clearly marked accordingly.

A.7 Permissible tools

Only the tools listed in Table A.1 may be used in undertaking the general vulnerability assessment.

NOTE This list is intended to give a general description of the tools allowed. It is not intended to give precise dimensions, or to fully detail the type of tool. A general tolerance of $\pm 10\%$ is acceptable on all dimensions and values.

Table A.1 List of tools permitted for use in the general vulnerability assessment

Item	Additional details
Screwdriver 0.10 m with slotted tip (may be used as a lever)	100 mm chrome vanadium screwdriver
Screwdriver 0.15 m with slotted tip (may be used as a lever)	150 mm chrome vanadium screwdriver
Screwdriver 0.20 m with slotted tip (may be used as a lever)	200 mm chrome vanadium screwdriver
0.5 kg (nom.) ball peen hammer	
Miniature hand hacksaw frame in accordance with BS 7398:1991, Type A, with integral tension	Junior blades
0.5 kg (nom.) claw hammer	
Mild steel tube 0.3 m long with 32 mm diameter, wall thickness 2 mm	
Pair of pliers	Combination pliers 200 mm
Allen key set – 1.5, 2.0, 2.5, 3.0, 4.0, 5.0, 6.0, 8.0, 10.0 mm	
Craft knife	Precision knife set
Tweezers	6 piece tweezer set
Wire	Various diameter to 4 mm – any length
Wedges	Various plastic/timber wedges as required
Multiple slip joint pliers (240 mm)	Slip joint utility pliers
6 mm wood chisel	
25 mm wood chisel	
Additional screw/nuts drivers suitable for the head forms shown in EN 12209, Figure B.7	
Parallel punch set (100/150 mm) 3.2, 4.0, 4.8, 5.5, 6.4 mm	

Table A.1 List of tools permitted for use in the general vulnerability assessment (continued)

Item	Additional details
20 piece screwdriver set, variety of sizes including slotted tip 3 – 12 mm, Phillips No. 0 – 3, Pozidrive No. 0 – 3	<ol style="list-style-type: none"> 1. Instrument 75 × 3 2. Instrument 150 × 3 3. Parallel tip 100 × 4 4. Parallel tip 150 × 5.5 5. Flared tip 40 × 6.5 stubby 6. Flared tip 150 × 6.5 7. Parallel tip 250 × 6.5 8. Flared tip 200 × 8 9. Flared tip 250 × 10 10. Flared tip 300 × 12 11. Pozidrive 60 × 0 12. Pozidrive 75 × 1 13. Pozidrive 30 × 2 stubby 14. Pozidrive 100 × 2 15. Pozidrive 150 × 3 16. Phillips 60 × 0 17. Phillips 30 × 1 stubby 18. Phillips 75 × 1 19. Phillips 100 × 2 20. Phillips 150 × 3
Drill bits HSS (1 – 13 mm)	<ol style="list-style-type: none"> 1.0 HSS drill bit 2.0 HSS drill bit 3.0 HSS drill bit 4.0 HSS drill bit 5.0 HSS drill bit 6.0 HSS drill bit 7.0 HSS drill bit 8.0 HSS drill bit 9.0 HSS drill bit 10.0 HSS drill bit 12.0 HSS drill bit 13.0 HSS drill bit
Vice grip set (125 mm & 250 mm, parallel jaws)	<p>125 mm</p> <p>250 mm</p>
Cordless drill (10 – 24 V, max 3 Ah)	
Pad saw & HSS blades	
Picking tools – cylinders	<p>Rake pick – HPC novice pick set</p> <p>Tensioner</p>

Table A.1 List of tools permitted for use in the general vulnerability assessment (*continued*)

Item	Additional details
Picking tools – lever	2 in 1 pick Overlift
Self tapping screws	Assorted – including purpose-designed traction screws or equivalent
Test key	[see Clause A.6, iii) and iv)]
Impactor	Any proprietary impactor appropriate to the manipulation techniques considered in Clause A.6 <i>NOTE Other tools in this list may also be used as impactors, e.g. the handle of a screwdriver</i>
Resilient device for attaching to the test key	
Petroleum based water displacement lubricant spray	

A.8 Assessment panel

The assessment shall in all cases be undertaken by a panel of three locksmiths each of whom can demonstrate expertise and experience such as to be able to form a reliable and disinterested judgement as simulated by the procedures specified in A.4 to A.7.

NOTE 1 Such expertise and experience could be demonstrated by the following criteria:

- a recognized qualification in locksmithing, achieved by examination (e.g BLI; ALOA)
- ten years experience as a practising locksmith; and
- current full membership in good standing, of not less than five years' continuous duration, of a professional locksmithing body.

NOTE 2 For assessments undertaken by a lock manufacturer, the experts may be directly employed or may be contracted for the purpose. A register containing details of some of those known to be appropriately qualified within the UK can be accessed by application to the BSI Knowledge Centre.

Annex B (normative) Product Information

Products submitted for testing or Sale claiming conformity to this PAS shall include:

- i) A product Information sheet displaying the following information, as a minimum:
 - Manufacturer name, address and contact details.
 - An illustration of the product showing all the locking, anti-separation and clenching points (see **figure B1**).
 - Against each locking and/or anti-separation, and/or clenching point the performance claimed.
 - Where a cylinder is used, the Grade of cylinder used to meet the GVA aspects of this PAS (Annex A).

- Where additional products are required to meet the criteria of this PAS, the exact specification of the products shall be defined.
- ii) Unambiguous, comprehensive instructions for the installation and maintenance of the locking assembly. These instructions shall contain, as a minimum:
- a) The limitation of the products intended use, the limitation of the door mass and door dimension, and the unsupported installation of the latch bolt or locking points and anti separation points.
 - b) Installation and fixing instructions to ensure that the product can achieve the performance requirements of this document, including any restriction in use, for example conditions under which the product could be rendered inoperable. In particular it shall be clearly stated which locking plates are suitable in combination with the lock and vice versa.
 - c) Maintenance instructions to ensure that the product continues to achieve the performance requirements in this document for reasonable economic working life.
 - d) Declaration of the maximum side load (25 N).

NOTE 1 The supplier may add additional information, for example the corrosion resistance, operating temperature range.

NOTE 2 For illustration purposes only, see the example provided as Figure B1.

Figure B.1 Example of the illustration required under j) above

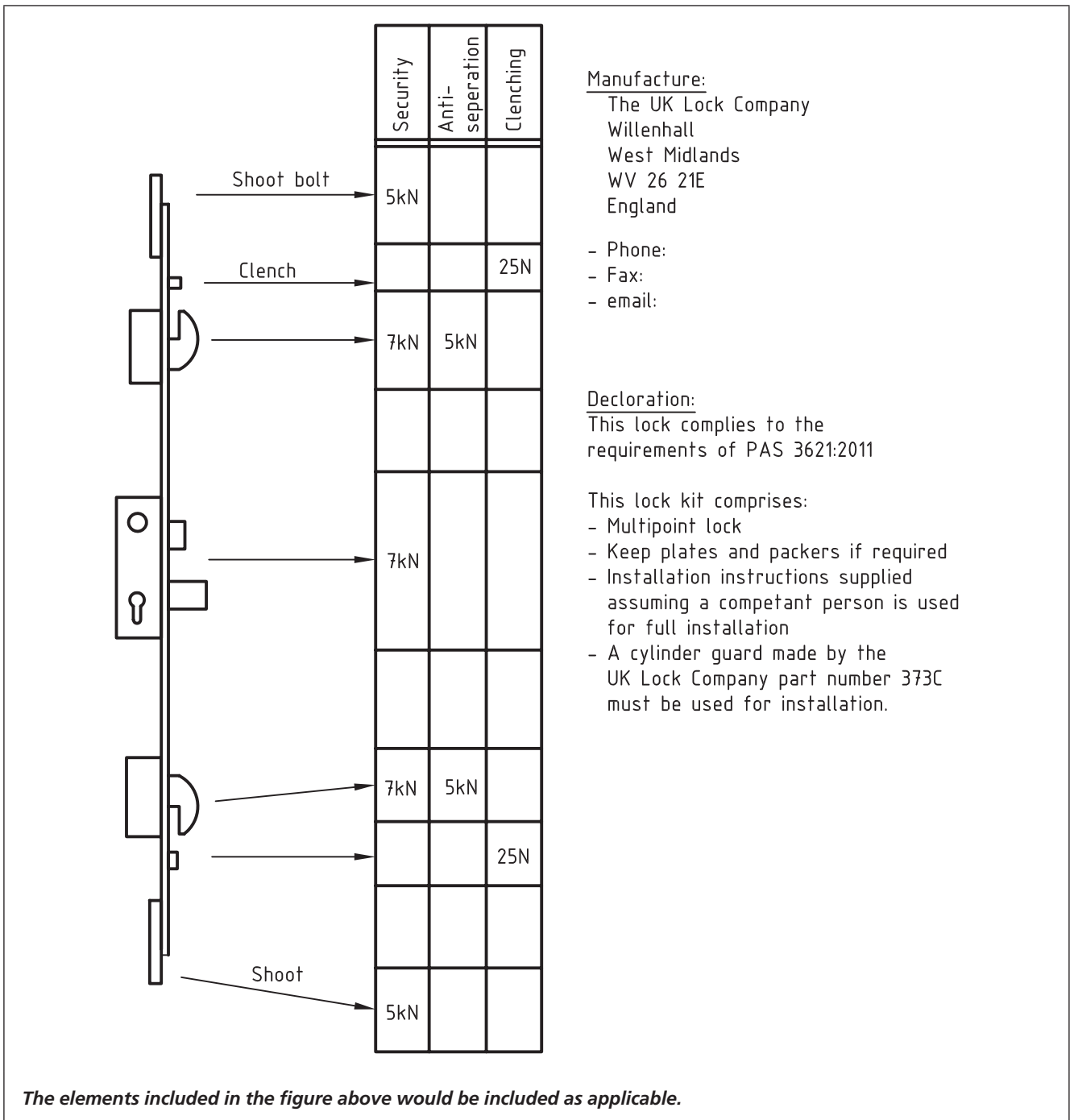

Annex C (normative) Test sampling and sequencing

Between six and twelve test samples, depending on type, shall be subjected to a sequence of test as shown in Table C.1:

Table C.1 Testing sampling and sequencing

Test for all locks (where applicable)						
Samples A and J	Samples B and K	Samples C and L	Samples D and M	Samples E and N	Samples F and O	Samples G and P
Coding protection (1,5) 7.9.5	Protection against removal from door (1) 7.7	Locking point projection (1) 7.5.3	Durability of locking snib mechanism (6) 7.2.3	Return force of latch bolt (2) 7.1.2	Durability of clenching action (6) 7.2.4	Torque resistance of lockable follower (2,4) 7.1.6/7.5.1
Differing step heights on key (1,5) 7.9.3	Minimum restoring torque (2) 7.1.1.4	Deadlocking (1) 7.8.2	Resistance to drilling and disengaging of anti-separation device (4) 7.10.2	Torque to operate lock (2) 7.1.4	Resistance to drilling and pulling of anti-separation device (4) 7.10.1	Corrosion resistance (2,4) 7.4.1
Operation at extremes of temperature (2) 7.4.2	Strength of key (2,5) 7.8.1	Detaining elements (1,5) 7.9.1	Resistance to pulling on locking plate for the anti-separation device (2,4) 7.10.3	Door closing force (2,3) 7.3.2	Resistance to end load on box protected locking plate (2,4) 7.5.5.	Resistance to side load on locking plate (2,4) 7.5.6
Durability of locking action (with/without force) (6) 7.2.2	Strength of follower stops (2) 7.1.5	Effective Differers (1,5) 7.9.2		Durability of latch action (with/without force) (3,6) 7.2.1		
Non interpassing of keys with just one interval differ (1,5) 7.9.4	Resistance to side load on locking point (2,4) 6.8.2.1			Strength of bolt action (2) 7.1		
Resistance to drilling and side load (2,4) 7.5.2		Resistance to drilling and end load on locking point (2,4) 7.5.4		Resistance to side load on latch bolts (2,4) 7.1.3		

British Standards Institution (BSI)

BSI is the independent national body responsible for preparing British Standards and other standards-related publications, information and services.

It presents the UK view on standards in Europe and at the international level.

It is incorporated by Royal Charter.

Revisions

British Standards are updated by amendment or revision. Users of British Standards should make sure that they possess the latest amendments or editions.

It is the constant aim of BSI to improve the quality of our products and services. We would be grateful if anyone finding an inaccuracy or ambiguity while using this British Standard would inform the Secretary of the technical committee responsible, the identity of which can be found on the inside front cover.

Tel: +44 (0)20 8996 9001 Fax: +44 (0)20 8996 7001

BSI offers Members an individual updating service called PLUS which ensures that subscribers automatically receive the latest editions of standards.

Tel: +44 (0)20 8996 7669 Fax: +44 (0)20 8996 7001

Email: plus@bsigroup.com

Buying standards

You may buy PDF and hard copy versions of standards directly using a credit card from the BSI Shop on the website www.bsigroup.com/shop. In addition all orders for BSI, international and foreign standards publications can be addressed to BSI Customer Services.

Tel: +44 (0)20 8996 9001 Fax: +44 (0)20 8996 7001

Email: orders@bsigroup.com

In response to orders for international standards, it is BSI policy to supply the BSI implementation of those that have been published as British Standards, unless otherwise requested.

Information on standards

BSI provides a wide range of information on national, European and international standards through its Knowledge Centre.

Tel: +44 (0)20 8996 7004 Fax: +44 (0)20 8996 7005

Email: knowledgecentre@bsigroup.com

Various BSI electronic information services are also available which give details on all its products and services.

Tel: +44 (0)20 8996 7111 Fax: +44 (0)20 8996 7048

Email: info@bsigroup.com

BSI Subscribing Members are kept up to date with standards developments and receive substantial discounts on the purchase price of standards. For details of these and other benefits contact Membership Administration.

Tel: +44 (0)20 8996 7002 Fax: +44 (0)20 8996 7001

Email: membership@bsigroup.com

Information regarding online access to British Standards via British Standards Online can be found at www.bsigroup.com/BSOL

Further information about BSI is available on the BSI website at www.bsigroup.com/standards

Copyright

Copyright subsists in all BSI publications. BSI also holds the copyright, in the UK, of the publications of the international standardization bodies. Except as permitted under the Copyright, Designs and Patents Act 1988 no extract may be reproduced, stored in a retrieval system or transmitted in any form or by any means – electronic, photocopying, recording or otherwise – without prior written permission from BSI. This does not preclude the free use, in the course of implementing the standard of necessary details such as symbols, and size, type or grade designations. If these details are to be used for any other purpose than implementation then the prior written permission of BSI must be obtained. Details and advice can be obtained from the Copyright & Licensing Manager.

Tel: +44 (0)20 8996 7070

Email: copyright@bsigroup.com

BSI Group Headquarters

389 Chiswick High Road London W4 4AL UK

Tel +44 (0)20 8996 9001

Fax +44 (0)20 8996 7001

www.bsigroup.com/standards