

# Particulate air filters for general ventilation — Determination of filtration performance

ICS 13.040.20

## National foreword

This Draft for Development is the UK implementation of ISO/TS 21220:2009.

**This publication is not to be regarded as a British Standard.**

It is being issued in the Draft for Development series of publications and is of a provisional nature. It should be applied on this provisional basis, so that information and experience of its practical application can be obtained.

Comments arising from the use of this Draft for Development are requested so that UK experience can be reported to the international organization responsible for its conversion to an international standard. A review of this publication will be initiated not later than 3 years after its publication by the international organization so that a decision can be taken on its status. Notification of the start of the review period will be made in an announcement in the appropriate issue of Update Standards.

According to the replies received by the end of the review period, the responsible BSI Committee will decide whether to support the conversion into an international Standard, to extend the life of the Technical Specification or to withdraw it. Comments should be sent to the Secretary of the responsible BSI Technical Committee at British Standards House, 389 Chiswick High Road, London W4 4AL.

The UK participation in its preparation was entrusted to Technical Committee MCE/21, Filters for gases and liquids.

A list of organizations represented on this committee can be obtained on request to its secretary.

This publication does not purport to include all the necessary provisions of a contract. Users are responsible for its correct application.

**Compliance with a British Standard cannot confer immunity from legal obligations.**

This Draft for Development was published under the authority of the Standards Policy and Strategy Committee on 30 November 2009.

© BSI 2009

ISBN 978 0 580 67483 9

### Amendments/corrigenda issued since publication

| Date | Comments |
|------|----------|
|      |          |
|      |          |
|      |          |
|      |          |

# TECHNICAL SPECIFICATION

# ISO/TS 21220

First edition  
2009-10-01

---

---

## Particulate air filters for general ventilation — Determination of filtration performance

*Filtres à air particulaires pour ventilation générale — Détermination  
des performances de filtration*



Reference number  
ISO/TS 21220:2009(E)

© ISO 2009

**PDF disclaimer**

This PDF file may contain embedded typefaces. In accordance with Adobe's licensing policy, this file may be printed or viewed but shall not be edited unless the typefaces which are embedded are licensed to and installed on the computer performing the editing. In downloading this file, parties accept therein the responsibility of not infringing Adobe's licensing policy. The ISO Central Secretariat accepts no liability in this area.

Adobe is a trademark of Adobe Systems Incorporated.

Details of the software products used to create this PDF file can be found in the General Info relative to the file; the PDF-creation parameters were optimized for printing. Every care has been taken to ensure that the file is suitable for use by ISO member bodies. In the unlikely event that a problem relating to it is found, please inform the Central Secretariat at the address given below.



**COPYRIGHT PROTECTED DOCUMENT**

© ISO 2009

All rights reserved. Unless otherwise specified, no part of this publication may be reproduced or utilized in any form or by any means, electronic or mechanical, including photocopying and microfilm, without permission in writing from either ISO at the address below or ISO's member body in the country of the requester.

ISO copyright office  
Case postale 56 • CH-1211 Geneva 20  
Tel. + 41 22 749 01 11  
Fax + 41 22 749 09 47  
E-mail [copyright@iso.org](mailto:copyright@iso.org)  
Web [www.iso.org](http://www.iso.org)

Published in Switzerland

# Contents

Page

|  |    |
|--|----|
| Foreword.....  | v  |
| Introduction .....                                       | vi |
| 1 Scope .....  | 1  |
| 2 Normative references .....                             | 1  |
| 3 Terms, definitions, symbols and abbreviated terms..... | 2  |
| 4 Filter .....   | 6  |
| 5 Classification/rating.....                             | 6  |
| 6 Test rig and equipment .....                           | 6  |
| 6.1 Test conditions .....                                | 6  |
| 6.2 Test rig .....                                       | 6  |
| 6.3 DEHS test aerosol generation .....                   | 7  |
| 6.4 KCI test aerosol generation .....                    | 10 |
| 6.5 Aerosol sampling system .....                        | 12 |
| 6.6 Flow measurement .....                               | 13 |
| 6.7 Particle counter.....                                | 13 |
| 6.8 Differential pressure-measuring equipment .....      | 13 |
| 6.9 Dust feeder .....                                    | 13 |
| 7 Qualification of test rig and apparatus .....          | 17 |
| 7.1 General.....   | 17 |
| 7.2 Air velocity uniformity in the test duct .....       | 17 |
| 7.3 Aerosol uniformity in the test duct .....            | 18 |
| 7.4 Particle counter sizing accuracy.....                | 18 |
| 7.5 Particle counter zero test.....                      | 19 |
| 7.6 Particle counter overload test .....                 | 19 |
| 7.7 100 % efficiency test.....                           | 19 |
| 7.8 Zero % efficiency test.....                          | 19 |
| 7.9 Aerosol generator response time .....                | 20 |
| 7.10 Correlation ratio .....                             | 20 |
| 7.11 Pressure drop checking .....                        | 20 |
| 7.12 Dust feeder air flow rate .....                     | 21 |
| 7.13 Reference filter check.....                         | 22 |
| 7.14 Activity of the aerosol neutralizer.....            | 23 |
| 7.15 Summary of qualification requirements .....         | 23 |
| 7.16 Apparatus maintenance .....                         | 24 |
| 8 Test materials .....                                   | 24 |
| 8.1 Test air .....                                       | 24 |
| 8.2 Test aerosol.....                                    | 24 |
| 8.3 Loading dust .....                                   | 25 |
| 8.4 Final filter .....                                   | 26 |
| 9 Test procedure .....                                   | 26 |
| 9.1 General.....   | 26 |
| 9.2 Preparation of filter to be tested .....             | 27 |
| 9.3 Initial pressure drop .....                          | 27 |
| 9.4 Initial efficiency measurement .....                 | 27 |
| 9.5 Conditioning test .....                              | 29 |
| 9.6 Dust loading .....                                   | 29 |
| 10 Uncertainty calculation of the test results .....     | 31 |

|  |  |           |
|--|--|-----------|
| <b>11</b>  | <b>Test report</b> .....                     | <b>32</b> |
| <b>11.1</b>  | <b>General</b> .....                         | <b>32</b> |
| <b>11.2</b>  | <b>Interpretation of test reports</b> .....  | <b>32</b> |
| <b>11.3</b>  | <b>Summary</b> .....                         | <b>33</b> |
| <b>11.4</b>  | <b>Efficiency</b> .....                      | <b>35</b> |
| <b>11.5</b>  | <b>Pressure drop and air flow rate</b> ..... | <b>35</b> |
| <b>11.6</b>  | <b>Marking</b> .....                         | <b>35</b> |
| <b>Annex A (normative) Conditioning test</b> .....         |  | <b>42</b> |
| <b>Annex B (informative) Shedding from filters</b> .....   |  | <b>45</b> |
| <b>Annex C (informative) Commentary</b> .....              |  | <b>47</b> |
| <b>Annex D (normative) Pressure drop calculation</b> ..... |  | <b>51</b> |
| <b>Bibliography</b> .....                                  |  | <b>53</b> |

## Foreword

ISO (the International Organization for Standardization) is a worldwide federation of national standards bodies (ISO member bodies). The work of preparing International Standards is normally carried out through ISO technical committees. Each member body interested in a subject for which a technical committee has been established has the right to be represented on that committee. International organizations, governmental and non-governmental, in liaison with ISO, also take part in the work. ISO collaborates closely with the International Electrotechnical Commission (IEC) on all matters of electrotechnical standardization.

International Standards are drafted in accordance with the rules given in the ISO/IEC Directives, Part 2.

The main task of technical committees is to prepare International Standards. Draft International Standards adopted by the technical committees are circulated to the member bodies for voting. Publication as an International Standard requires approval by at least 75 % of the member bodies casting a vote.

In other circumstances, particularly when there is an urgent market requirement for such documents, a technical committee may decide to publish other types of document:

- an ISO Publicly Available Specification (ISO/PAS) represents an agreement between technical experts in an ISO working group and is accepted for publication if it is approved by more than 50 % of the members of the parent committee casting a vote;
- an ISO Technical Specification (ISO/TS) represents an agreement between the members of a technical committee and is accepted for publication if it is approved by 2/3 of the members of the committee casting a vote.

An ISO/PAS or ISO/TS is reviewed after three years in order to decide whether it will be confirmed for a further three years, revised to become an International Standard, or withdrawn. If the ISO/PAS or ISO/TS is confirmed, it is reviewed again after a further three years, at which time it must either be transformed into an International Standard or be withdrawn.

Attention is drawn to the possibility that some of the elements of this document may be the subject of patent rights. ISO shall not be held responsible for identifying any or all such patent rights.

ISO/TS 21220 was prepared by Technical Committee ISO/TC 142, *Cleaning equipment for air and other gases*.

## Introduction

This Technical Specification is based on EN 779<sup>[5]</sup> and ANSI/ASHRAE 52.2<sup>[1]</sup>, and covers the testing of the performance of air filters mainly used in general ventilation applications. During its preparation, it was perceived that the document was not sufficiently mature for publication as an International Standard, and so its publication as a Technical Specification was decided as an intermediate step. Moreover, with such a document covering the needs of the air filtration industry and of the end users, it is envisaged that a future revision in the form of an International Standard could also include a classification system.

The classification or rating of air filters is determined by national bodies or other associations and is not within the scope of this Technical Specification

In the method set out in this Technical Specification, representative samples of particles upstream and downstream of the filters are analysed by an optical particle counter (OPC) to provide filter particle size efficiency data.

Initiatives to address the potential problems of particle re-entrainment, shedding and the in-service charge neutralization characteristics of certain types of media are presented.

Certain types of filter media rely on electrostatic effects to achieve high efficiencies at low resistance to air flow. Exposure to some types of challenge, such as combustion particles or other fine particles, can inhibit such charges, with the result that filter performance suffers. The conditioning test procedure given in Annex A provides techniques for identifying this type of behaviour and can be used both to determine whether the filter efficiency is dependent on the electrostatic removal mechanism and to provide quantitative information about the importance of the electrostatic removal. This procedure was selected because it is well established, reproducible, simple to perform and relatively quick and ultimately because an acceptable alternative procedure was not available.

In an ideal filtration process, each particle would be permanently arrested at the first contact with a filter fibre, but incoming particles can impact on a captured particle and dislodge it into the air stream. Fibres or particles from the filter itself could also be released, due to mechanical forces. From the user's point of view it might be important to know this, and a description is given in Annex B.

A brief overview of the test method and its principles is given in Annex C.

A means for calculating pressure drop is set out in Annex D.



# Particulate air filters for general ventilation — Determination of filtration performance

## 1 Scope

This Technical Specification presents test methods and specifies a test rig for measuring the filter performance of particulate air filters used for general ventilation. The test rig is designed for an air flow rate of between 0,25 m<sup>3</sup>/s [900 m<sup>3</sup>/h (530 ft<sup>3</sup>/min)] and 1,5 m<sup>3</sup>/s [5 400 m<sup>3</sup>/h (3 178 ft<sup>3</sup>/min)].

This Technical Specification is applicable to air filters having an initial efficiency of less than 99 % with respect to 0,4 µm particles. Filters in the higher end and those with an above 99 % initial efficiency are tested and classified according to other standards.

It combines two test methods: a “fine” method for air filters in the higher efficiency range and a “coarse” method for filters of lower efficiency. In either case, a flat-sheet media sample or media pack sample from an identical filter is conditioned (discharged) to provide information about the intensity of the electrostatic removal mechanism. After determination of its initial efficiency, the untreated filter is loaded with synthetic dust in a single step until its final test pressure drop is reached. Information on the loaded performance of the filter is then obtained.

The performance results thus obtained cannot alone be quantitatively applied to predict in-service performance with regard to efficiency and lifetime, so other factors influencing performance are presented in Annexes A and B.

## 2 Normative references

The following referenced documents are indispensable for the application of this document. For dated references, only the edition cited applies. For undated references, the latest edition of the referenced document (including any amendments) applies.

ISO 2854, *Statistical interpretation of data — Techniques of estimation and tests relating to means and variances*

ISO 5167-1:2003, *Measurement of fluid flow by means of pressure differential devices inserted in circular cross-section conduits running full — Part 1: General principles and requirements*

ISO 12103-1:1997, *Road vehicles — Test dust for filter evaluation — Part 1: Arizona test dust*

ISO 21501-1, *Determination of particle size distribution — Single particle light interaction methods — Part 1: Light scattering aerosol spectrometer*

ISO 21501-4, *Determination of particle size distribution — Single particle light interaction methods — Part 4: Light scattering airborne particle counter for clean spaces*

JIS Z 8901:1995, *Test powders and test particles*<sup>1)</sup>

---

1) Japanese Industrial Standard.

### 3 Terms, definitions, symbols and abbreviated terms

For the purposes of this document, the following terms, definitions, symbols and abbreviated terms apply.

#### 3.1 arrestance

$A$   
weighted (mass) removal of loading dust by a filter

NOTE It is expressed as the percentage of the dust captured by the filter in terms of the mass of the total dust fed into it.

#### 3.2 average arrestance

$A_m$   
ratio of the total amount of loading dust retained by the filter to the total amount of dust fed up to the final test pressure drop

#### 3.3 charged filter

filter in which the filter media is electrostatically charged or polarized

#### 3.4 conditioned efficiency

efficiency of the conditioned filter media operating at an average media velocity corresponding to the test air flow rate in the filter

#### 3.5 counting rate

number of counting events per unit of time

#### 3.6 correlation ratio

ratio of downstream to upstream particle counts without the test filter in the test duct

#### 3.7 DEHS DiEthylHexylSebacate

liquid used for generating the DEHS test aerosol

#### 3.8 dust loaded efficiency

efficiency of the filter operating at test flow rate and after dust loadings up to the final test pressure drops

#### 3.9 effective filtering area

area of filter medium in the filter which collects dust

#### 3.10 filter face area

frontal face area of the filter including the header frame

NOTE Nominal values: 0,61 m × 0,61 m (24 in × 24 in).

#### 3.11 filter face velocity

air flow rate divided by the filter face area

**3.12**

**final filter**

air filter used to collect the loading dust passing through or shedding from the filter under test

**3.13**

**final test pressure drop**

pressure drop of the filter up to which the filtration performance is measured

**3.14**

**initial efficiency**

efficiency of the clean untreated filter operating at the test air flow rate

**3.15**

**initial pressure drop**

pressure drop of the clean filter operating at the test air flow rate

**3.16**

**isokinetic sampling**

sampling of the air within a duct such that the probe inlet air velocity is the same as the velocity in the duct at the sampling point

**3.17**

**KCl**

solid potassium chloride (KCl) particles generated from an aqueous solution and used as a test aerosol

**3.18**

**loading dust**

**synthetic test dust**

test dust specifically formulated for loading of the filter

NOTE Two types of loading dusts are used: ISO 12103-A fine test dust is used for the loading of filters according to the fine dust method and ASHRAE dust is used for the filters tested according to the coarse method.

**3.19**

**mean diameter**

geometric mean of the upper and lower border diameters in a size range

**3.20**

**media velocity**

air flow rate divided by the effective filtering area

NOTE It is expressed to an accuracy of three significant figures.

**3.21**

**minimum efficiency**

lowest efficiency of initial, conditioned or dust loaded efficiencies

**3.22**

**neutralization**

process by which the aerosol is brought to a Boltzmann charge equilibrium distribution with bipolar ions

**3.23**

**particle bounce**

behaviour of particles that impinge on the filter without being retained

**3.24**

**particle size**

equivalent optical diameter of a particle

**3.25**

**particle number concentration**

number of particles per unit volume of the test air

**3.26**

**penetration**

ratio of the particle concentration downstream to upstream of the filter

**3.27**

**recommended final pressure drop**

maximum operating pressure drop of the filter as recommended by the manufacturer at rated air flow

**3.28**

**re-entrainment**

release to the air flow of particles previously collected on the filter

**3.29**

**shedding**

release to the air flow of particles due to particle bounce and re-entrainment as well as the release of fibres or particulate matter from the filter or filtering material

**3.30**

**test air flow rate**

volumetric rate of air flow through the filter under test

**3.31**

**test aerosol**

aerosol used for determining the efficiency of the filter

**3.32**

**test dust capacity**

**TDC**

dust holding capacity (deprecated)

DHC (deprecated)

amount of loading dust kept by the filter at the final test pressure drop

|                     |   |
|---------------------|---|
| $A$                 | Arrestance, %   |
| $A_m$               | Average arrestance during test to final test pressure drop, % |
| CL                  | Concentration limits of particle counter                      |
| $C_V$               | Coefficient of variation                                      |
| $C_{V,i}$           | Coefficient of variation in size range $i$                    |
| $C_{\text{mean},i}$ | Mean of measuring points value for size range $i$             |
| DEHS                | DiEthylHexylSebacate  |
| $d_i$               | Geometric mean of size range $i$ , $\mu\text{m}$              |
| $d_l$               | Lower border diameter in a size range, $\mu\text{m}$          |
| $d_u$               | Upper border diameter in a size range, $\mu\text{m}$          |
| $\overline{E}_i$    | Average efficiency in size range $i$                          |
| $m$                 | Mass passing filter, g  |
| $m_d$               | Mass of dust downstream of the test filter, g                 |
| $m_{\text{tot}}$    | Cumulative mass of dust fed to filter, g                      |
| $m_1$               | Mass of final filter before dust increment, g                 |

|                                       |   |
|---------------------------------------|---|
| $m_2$                                 | Mass of final filter after dust increment, g                            |
| $N$                                   | Number of points  |
| $N_d$                                 | Number of particles downstream of the filter                            |
| $N_{d,i}$                             | Number of particles in size range $i$ downstream of the filter          |
| $\overline{N_d}$                      | Average number of particles downstream of the filter                    |
| $N_u$                                 | Number of particles upstream of the filter                              |
| $N_{u,i}$                             | Number of particles in size range $i$ upstream of the filter            |
| $\overline{N_u}$                      | Average number of particles upstream of the filter                      |
| $n$                                   | Exponent  |
| OPC                                   | Optical particle counter  |
| $p$                                   | Pressure, Pa (in WG) <sup>2)</sup>                                      |
| $p_a$                                 | Absolute air pressure upstream of filter, kPa (in WG)                   |
| $p_{sf}$                              | Air flow meter static pressure, kPa (lb/in <sup>2</sup> )               |
| $q_m$                                 | Mass flow rate at air flow meter, kg/s (lb/s)                           |
| $q_V$                                 | Air flow rate at filter, m <sup>3</sup> /s (ft <sup>3</sup> /min)       |
| $R$                                   | Correlation ratio   |
| $R_i$                                 | Correlation ratio for size range $i$                                    |
| $T$                                   | Temperature upstream of filter, °C (°F)                                 |
| $T_f$                                 | Temperature at air flow meter, °C (°F)                                  |
| TDC                                   | Test dust capacity, g [formerly dust holding capacity (DHC)]            |
| $t_{\left(1-\frac{\alpha}{2}\right)}$ | Distribution variable   |
| $U$                                   | Uncertainty, % units  |
| $v_{\text{mean}}$                     | Mean value of velocity, m/s (ft/min)                                    |
| $\delta$                              | Standard deviation  |
| $\nu$                                 | Number of degrees of freedom  |
| $\rho$                                | Air density, kg/m <sup>3</sup> (lb/ft <sup>3</sup> )                    |
| $\varphi$                             | Relative humidity upstream of filter, %                                 |
| $\Delta m$                            | Dust increment, g   |
| $\Delta m_{\text{ff}}$                | Mass gain of final filter, g  |
| $\Delta p$                            | Filter pressure drop, Pa (in WG)  |
| $\Delta p_f$                          | Air flow meter differential pressure, Pa (in WG)                        |
| $\Delta p_{1,20}$                     | Filter pressure drop at air density 1,20 kg/m <sup>3</sup> , Pa (in WG) |

---

2) Water inch gauge (non-SI unit).

## 4 Filter

The filter shall be designed or marked so as to prevent incorrect mounting. It shall be designed so that when correctly mounted in the ventilation duct, no air/dust leaks occur around the exterior filter frame or duct sealing surfaces.

The complete filter (filter and frame) shall be made of materials suitable for withstanding normal usage and exposure to the range of temperature, humidity and corrosive environments likely to be encountered in service.

The complete filter shall be designed to withstand mechanical constraints that are likely to be encountered during normal use. Dust or fibre released from the filter media by air flow through the filter shall not constitute a hazard or nuisance for people or devices exposed to filtered air.

## 5 Classification/rating

Filters are not classified or rated by this Technical Specification. Many national bodies and associations use 0,944 m<sup>3</sup>/s (2 000 ft<sup>3</sup>/min or 3 400 m<sup>3</sup>/h) as the nominal air flow for classification or rating of air filters that are a nominal 0,61 m × 0,61 m (24 in × 24 in) in face area. It is therefore recommended that filters be tested at 0,944 m<sup>3</sup>/s (if the manufacturer does not specify any other flow for another application). The air flow velocity associated with the volumetric flow is 2,54 m/s (500 ft/min).

## 6 Test rig and equipment

### 6.1 Test conditions

Either room air or outdoor air may be used as the test air source. Relative humidity shall be less than 65 % for the KCl efficiency measurement and less than 75 % in the other tests. The exhaust flow may be discharged outdoors, indoors or recirculated.

NOTE Requirements on certain measuring equipment can impose limits on the temperature of the test air.

Filtration of the exhaust flow is recommended when test aerosol, loading dust or odours from the filter can be present.

### 6.2 Test rig

The test rig (see Figure 1) shall consist of several square duct sections with 610 mm × 610 mm (24 in × 24 in) nominal inner dimensions except for the section where the filter is installed. This section shall have nominal inner dimensions between 616 mm (24,25 in) and 622 mm (24,50 in). The length of this duct section shall be at least 1,1 times the length of the filter, with a minimum length of 1 m (39,4 in).

The duct material shall be electrically conductive and electrically grounded, and shall have a smooth interior finish and be sufficiently rigid to maintain its shape at the operating pressure. Smaller parts of the test duct could be made in glass or plastic in order to make the filter and equipment visible. Provision of windows to allow monitoring of test progress is desirable.

High-efficiency filters shall be placed upstream of section 1, as indicated in Figure 1, in which the aerosol for efficiency testing is dispersed and mixed to create a uniform concentration upstream of the filter.

Section 2 includes in the upstream section the mixing orifice (3) in the centre of which the dust feeder discharge nozzle is located. Downstream of the dust feeder is a perforated plate (11) intended to achieve a uniform dust distribution. In the last third of this duct section is the upstream aerosol sample head. For dust loading tests, this sampling head shall be blanked off or removed.

To avoid turbulence, the mixing orifice and the perforated plate should be removed during the efficiency test. To avoid systematic error, removal of these items during pressure drop measurements is recommended.

Section 5 may be used for both efficiency and dust loading measurements and is fitted with a final filter for the loading test and with the downstream sampling head for the efficiency test. Section 5 could also be duplicated, allowing one part to be used for the loading test and the other for the efficiency test.

The test rig can be operated in either a negative or positive pressure air flow arrangement. In the case of positive pressure operation (i.e. the fan upstream of the test rig), the test aerosol and loading dust could leak into the laboratory, while at negative pressure particles could leak into the test system and affect the number of measured particles. These possible air leaks shall be located and sealed prior to filter testing.

The dimensions of the test rig and the position of the pressure taps are shown in Figure 2. Additional duct details are shown in Figure 3.

The pressure drop of the tested filter shall be measured using static pressure taps located as shown in Figure 3. Pressure taps shall be provided at four points over the periphery of the duct and connected together by a ring line.

The entry plenum and the relative location of high-efficiency filters and aerosol injections are discretionary and a bend in the duct is optional, thereby allowing both straight duct and U-shaped duct configurations. Except for the bend itself, all dimensions and components are the same for straight and U-shaped configurations. A downstream mixing baffle shall be included in the duct after the bend, whose purpose is to straighten out the flow and mix any aerosol that is downstream of the bend.

### 6.3 DEHS test aerosol generation

The test aerosol shall consist of untreated and undiluted DEHS, or other aerosols in accordance with 8.2. A test aerosol of DEHS (DiEthylHexylSebacate) produced by a Laskin nozzle aerosol generator is widely used in the performance testing of high-efficiency filters.

Figure 4 gives an example of a system for generating the aerosol. It consists of a small container with DEHS liquid and a Laskin nozzle. The aerosol is generated by feeding compressed particle-free air through the Laskin nozzle. The atomized droplets are then directly introduced into the test rig. The pressure and air flow to the nozzle are varied according to the test flow and the required aerosol concentration. For a test flow of 0,944 m<sup>3</sup>/s (2 000 ft<sup>3</sup>/min), the pressure is about 17 kPa (2,5 lb/in<sup>2</sup>), corresponding to an air flow of about 0,39 dm<sup>3</sup>/s [1,4 m<sup>3</sup>/h (0,82 ft<sup>3</sup>/min)] through the nozzle.

Any other generator capable of producing droplets in sufficient concentrations in the size range of 0,3 µm to 1,0 µm may be used.

Before testing, regulate the upstream concentration so as to reach steady state and obtain a concentration below the coincidence level of the particle counter.

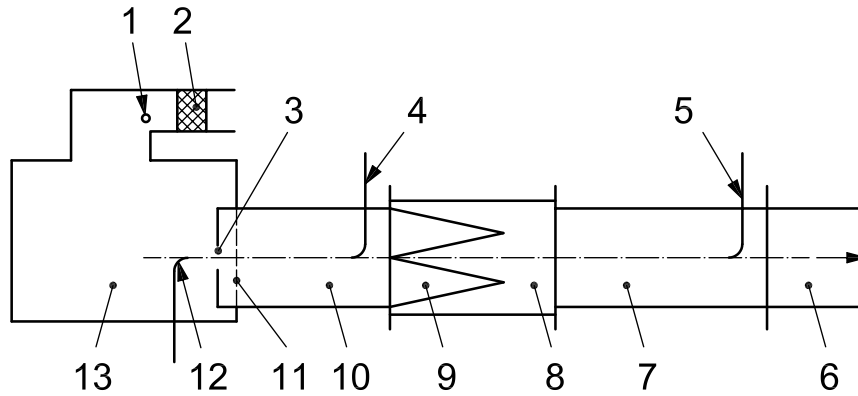

**Key**

- 1 inlet point for DEHS particles
- 2 high-efficiency filter (at least 99,97 % on 0,3  $\mu\text{m}$  particles)
- 3 mixing orifice
- 4 upstream sampling head
- 5 downstream sampling head
- 6 duct section of the test rig
- 7 duct section of the test rig
- 8 duct section including the filter to be tested
- 9 filter to be tested
- 10 duct section of the test rig
- 11 perforated plate
- 12 dust injection nozzle
- 13 duct section of the test rig (entry plenum)

**Figure 1 — Test rig — Schematic diagram**

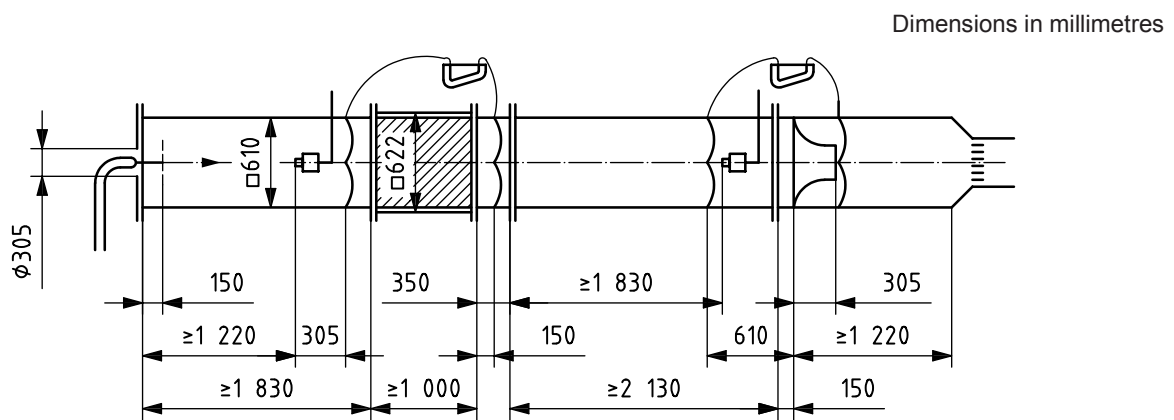

**Figure 2 — Test rig dimensions**



Dimensions in millimetres

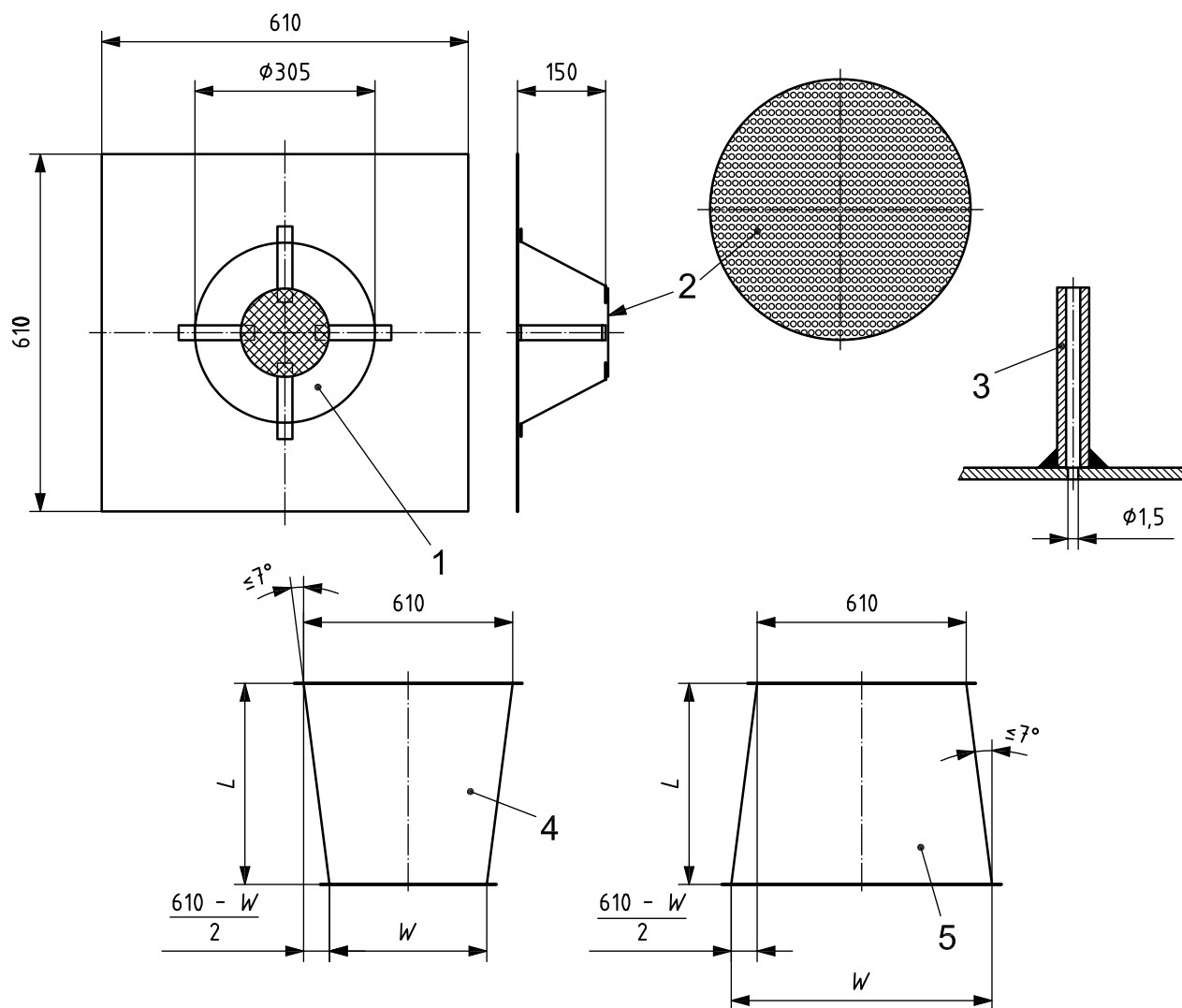

**Key**

- 1 mixing orifice
- 2 perforated plate with  $\varnothing (152 \pm 2)$  mm and 40 % open area
- 3 pressure tap
- 4 transition duct — test filter smaller than duct
- 5 transition duct — test filter larger than duct
- L* length
- W* width

**Figure 3 — Test duct component details**

Dimensions in millimetres

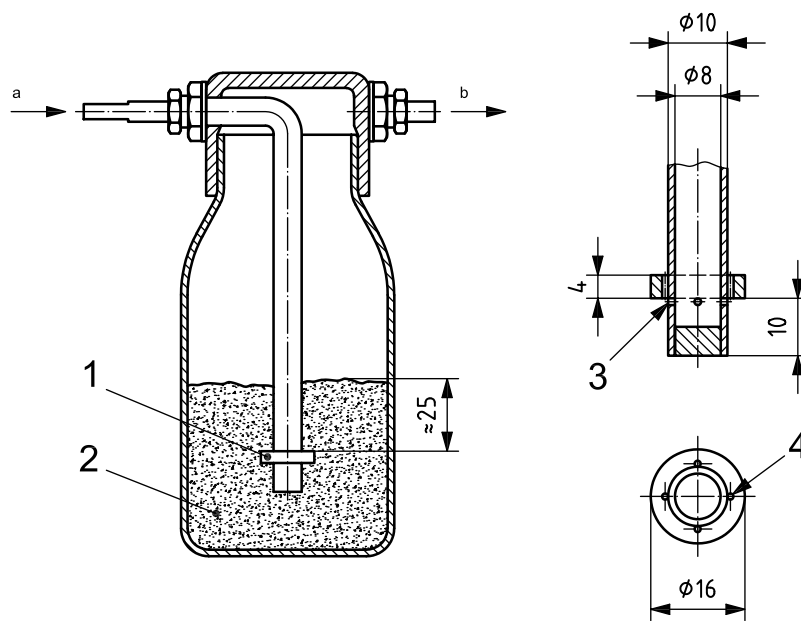

**Key**

- 1 Laskin nozzle
- 2 test aerosol (for instance DEHS)
- 3 hole, four of  $\varnothing$  1,0 mm, 90° apart, vis a vis hole top edge and just touching the bottom of the collar
- 4 hole, four of  $\varnothing$  2,0 mm next to tube, in line with radial holes
- a Particle-free air [pressure aprox. 17 kPa (2,5 lb/in<sup>2</sup>)].
- b Aerosol to test rig.

**Figure 4 — DEHS particle generation system**

**6.4 KCl test aerosol generation**

The test aerosol shall comprise solid-phase dry potassium chloride (KCl) in particulate form, generated from an aqueous solution.

The aerosol is generated by nebulizing an aqueous KCl solution with an external mixing air atomizing nozzle, as shown in Figure 5. Operate the spray nozzle at a relatively low air pressure to keep the particle concentrations in the duct below the coincidence error concentration limit of the particle counter.

Position the nozzle at the top of a 305 mm (12 in) diameter, 1 300 mm (51 in) high transparent acrylic spray tower. This high tower serves two purposes: it allows the salt droplets to dry by providing an approximately 40 s mean residence time and larger-sized particles to fall out of the aerosol.

Use an aerosol neutralizer to reduce the charge level on the aerosol until the level is equivalent to a Boltzmann charge distribution, the average charge found in ambient air. Electrostatic charging is an unavoidable consequence of most aerosol generation methods.

Inject the aerosol in the entry plenum counter to the air flow in order to improve the mixing of the aerosol with the airstream.

Prepare the KCl solution by combining 300 g of KCl with 1 kg of distilled water. Feed the solution to the atomizing nozzle at 1,2 ml/min by a metering pump. Varying the operating air pressure of the generator allows control of the challenge aerosol concentration.

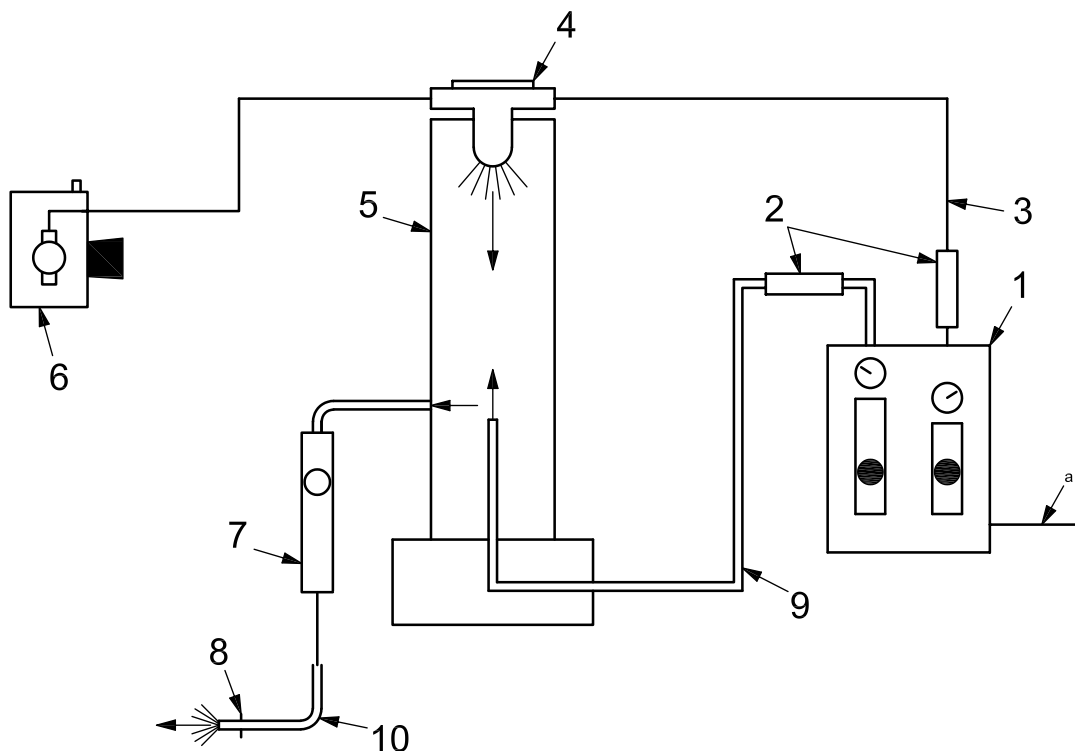

**Key**

- 1 air control panel (rotometers with needle valve and outlet pressure gauge)
- 2 99,97 % efficiency filters (0,3  $\mu\text{m}$ )
- 3 atomizing air — 0,000 5  $\text{m}^3/\text{s}$  (1  $\text{ft}^3/\text{min}$ ) nominal (adjusted speed)
- 4 air atomizing nozzle
- 5 spray tower — 305 mm (12 in) diameter, 1 300 mm (51 in) height
- 6 metering pump 1,2 ml/min, 30 % mass fraction KCl in water (solution)
- 7 aerosol charger neutralizer
- 8 disk — 152 mm (6 in) outer diameter — to create turbulence in airstream and mix aerosol
- 9 drying air — 0,001 9  $\text{m}^3/\text{s}$  (4  $\text{ft}^3/\text{min}$ )
- 10 tube — 38 mm (1,5 in) inner diameter — with outlet towards airstream
- <sup>a</sup> Clean, dry compressed air source.

**Figure 5 — KCl particle generator system — Schematic diagram**

## 6.5 Aerosol sampling system

In the aerosol sampling system, two sample lines of equal length and equivalent geometry (bends and straight lengths) shall connect the upstream and downstream sampling heads to the particle counter. The sample tubes shall be electrically conducting or have a high dielectric constant. The tubing shall have a smooth inside surface (steel, tygon, etc.).

Tapered sampling probes shall be placed in the centre of the upstream and downstream measuring sections. The sampling heads shall be centrally located with the inlet tip facing the inlet of the rig parallel to the air flow. The sampling shall be isokinetic within 10 % at a test flow rate of 0,944 m<sup>3</sup>/s (2 000 ft<sup>3</sup>/min).

Three one-way valves shall be used to make it possible to sample the aerosol upstream or downstream of the filter under test, or to have a “blank” suction through a high-efficiency filter. These valves shall be of a straight-through design. Due to possible particle losses from the sampling system, the first measurement after a valve is switched should be ignored.

The flow rate can be maintained by the pump in the counter in the case of a particle counter with a high flow rate [e.g. 0,47 × 10<sup>-3</sup> m<sup>3</sup>/s (1 ft<sup>3</sup>/min)] or by an auxiliary pump in the case of a counter with smaller sample flow rates. The exhaust line (to the pump) shall then be fitted with an isokinetic sampling nozzle directly connected to the particle counter to achieve isokinetic conditions within a tolerance of ± 10 %.

Particle losses will occur in the test duct, aerosol transport lines and particle counter. Minimization of particle losses is desirable because a smaller number of counted particles will mean larger statistical errors and thus less accurate results. The influence of particle losses on the result is minimized if the upstream and downstream sampling losses are made as nearly equal as possible.

Figure 6 shows an example of an aerosol sampling system.

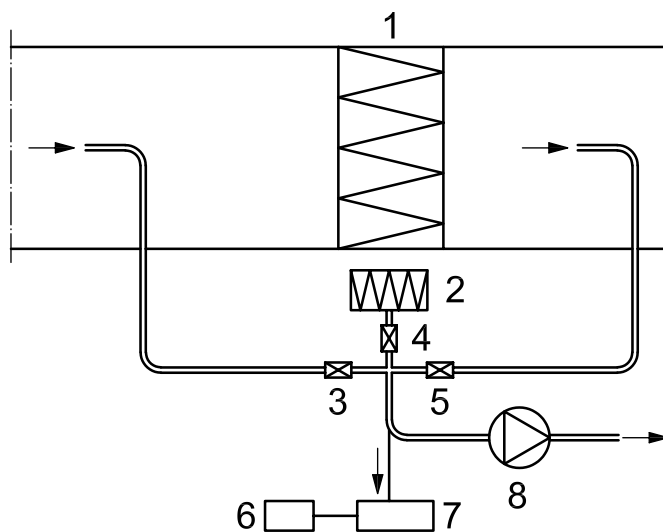

### Key

- 1 filter
- 2 high-efficiency filter (clean air)
- 3 valve, upstream
- 4 valve, clean air
- 5 valve, downstream
- 6 computer
- 7 particle counter
- 8 pump

Figure 6 — Aerosol sampling system — Schematic diagram

## 6.6 Flow measurement

Flow measurement shall be made using standardized flow measuring devices in accordance with ISO 5167-1.

EXAMPLE Orifice plates, nozzles, Venturi tubes.

The uncertainty of measurement shall not exceed 5 % of the measured value at 95 % confidence level.

## 6.7 Particle counter

This method requires the use of an optical particle counter (OPC) having a particle size range of at least 0,3  $\mu\text{m}$  to 5,5  $\mu\text{m}$  or two counters covering the size range 0,3  $\mu\text{m}$  to 1,2  $\mu\text{m}$  and 1  $\mu\text{m}$  to 5,5  $\mu\text{m}$ . The counting efficiency shall be  $(50 \pm 20)$  % for calibration particles with a size close to the minimum detectable size and  $(100 \pm 10)$  % for calibration particles 1,5 to 2 times larger than the minimum detectable particle size. Each size range shall be divided into at least five size classes, the boundaries of which should be approximately equidistant on a logarithmic scale. If a single counter is used to cover the entire size range, a minimum of eight size classes are required.

The number of particle size measurements will enable the user to generate a curve of efficiency vs. particle size data covering at least the 0,3  $\mu\text{m}$  to 5,5  $\mu\text{m}$  particle size range. The efficiency can then be calculated (by interpolation) for any given geometric particle size, for example 0,4  $\mu\text{m}$ , 1  $\mu\text{m}$ , 1,5  $\mu\text{m}$ , 2,5  $\mu\text{m}$  and 5  $\mu\text{m}$ .

The efficiency measurements may be made with one particle counter sampling sequentially upstream and downstream or performed with two particle counters sampling simultaneously. If two particle counters are used, they shall be closely matched in design and sampling flow rate.

Clause 7 contains further information and details about the calibration and operation of an OPC used for this test.

An example of how a single or dual particle counter system might be configured is given by Table 1.

## 6.8 Differential pressure-measuring equipment

Measurements of pressure drop shall be taken between measuring points located in the duct wall as shown in Figure 2. Each measuring point shall comprise four interconnected static taps equally distributed around the periphery of the duct cross-section.

The pressure-measuring equipment used shall be capable of measuring pressure differences with an accuracy of  $\pm 2$  Pa ( $\pm 0,01$  in WG) in the range 0 Pa to 70 Pa (0,28 in WG). Above 70 Pa (0,28 in WG), the accuracy shall be  $\pm 3$  % of the measured value.

## 6.9 Dust feeder

The purpose of the dust feeder is to supply the synthetic dust to the filter under test at a constant rate over the test period. The general design of the dust feeder and its critical dimensions are as shown and given in Figures 7 and 8. Any dust feeder may be chosen as long as it gives the same test result as the described dust feeder.

The angle between the dust pickup tube and dust feed tray is  $90^\circ$  as shown in Figure 7 but could be less in real application. A certain mass of dust previously weighed is loaded into the mobile dust feeder tray. The tray moves at a uniform speed and the dust is taken up by a paddle wheel and carried to the slot of the dust pickup tube of the ejector.

The ejector disperses the dust with compressed air and directs it into the test rig through the dust feed tube. The dust injection nozzle shall be positioned at the entrance of duct section 2 (see Figure 1) and be collinear with the duct centre line.

Backflow of air through the pickup tube from the positive duct pressure shall be prevented when the feeder is not in use.

**Table 1 — Dual/single particle counter system configuration — Examples**

| <b>Dual counter example</b>    |                                 |   |
|--------------------------------|---------------------------------|---|
| <b>Class</b>                   | <b>Channel boundaries</b><br>µm | <b>Geometric mean diameter of range</b><br>µm |
| <b>Counter 1, fine range</b>   |                                 |   |
| Class 1                        | 0,3–0,4                         | 0,35  |
| Class 2                        | 0,4–0,52                        | 0,46  |
| Class 3                        | 0,52–0,7                        | 0,6   |
| Class 4                        | 0,7–0,9                         | 0,8   |
| Class 5                        | 0,9–1,2                         | 1,0   |
| <b>Counter 2, coarse range</b> |                                 |   |
| Class 1                        | 1,0–1,4                         | 1,2   |
| Class 2                        | 1,4–2,0                         | 1,7   |
| Class 3                        | 2,0–2,8                         | 2,4   |
| Class 4                        | 2,8–4,0                         | 3,4   |
| Class 5                        | 4,0–5,5                         | 4,7   |
| <b>Single counter example</b>  |                                 |   |
| <b>Class</b>                   | <b>Channel boundaries</b><br>µm | <b>Geometric mean diameter of range</b><br>µm |
| <b>Complete range</b>          |                                 |   |
| Class 1                        | 0,3–0,45                        | 0,4   |
| Class 2                        | 0,45–0,65                       | 0,5   |
| Class 3                        | 0,65–1,0                        | 0,8   |
| Class 4                        | 1,0–1,5                         | 1,2   |
| Class 5                        | 1,5–2,2                         | 1,8   |
| Class 6                        | 2,2–3,0                         | 2,6   |
| Class 7                        | 3,0–4,0                         | 3,5   |
| Class 8                        | 4,0–5,5                         | 4,7   |

The degree of dust dispersion by the feeder is dependent on the characteristics of the compressed air, the geometry of the aspirator assembly and the rate of air flow through the aspirator. The aspirator Venturi is subject to wear from the aspirated dust and will become enlarged with use. Its dimension shall be monitored periodically to ensure that the tolerances shown in Figure 8 are met.

The gauge pressure on the air line to the Venturi, corresponding to an air flow of the dust-feeder pipe of  $6,8 \times 10^{-3} \text{ m}^3/\text{s} \pm 0,24 \times 10^{-3} \text{ m}^3/\text{s}$  ( $14,5 \text{ ft}^3/\text{min} \pm 0,5 \text{ ft}^3/\text{min}$ ), shall be measured periodically for different static pressures in the duct. See 7.12 for qualification requirements of the dust feeder.

Dimensions in millimetres

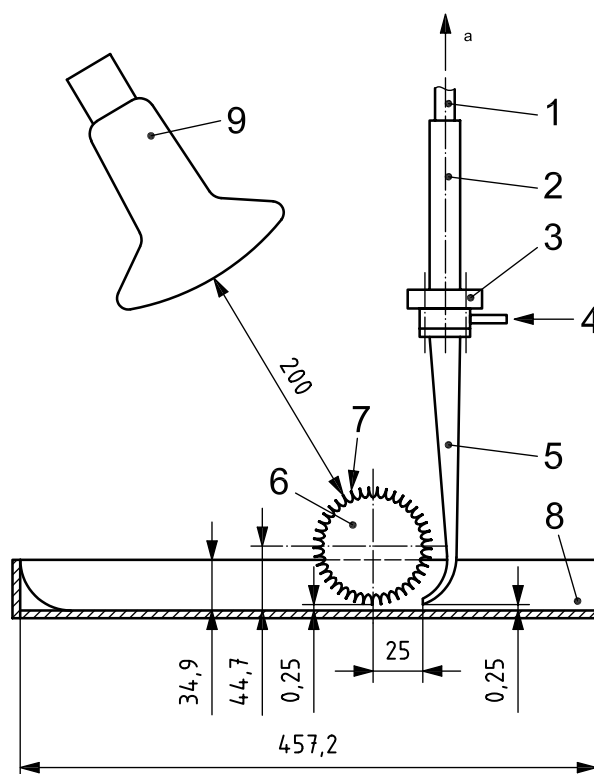

**Key**

- 1 thin-wall galvanised conduit
- 2 Venturi ejector
- 3 ejector
- 4 dry compressed air feed
- 5 dust pickup tube (0,25 mm from dust feed tray)
- 6 dust paddle wheel —  $\varnothing$  88,9 mm (outer dimension), 114,3 mm long with 60 teeth 5 mm deep
- 7 teeth in paddle wheel (60 teeth)
- 8 dust feed tray
- 9 150 W infrared-reflector lamp
- a Dust feed tube to inlet of test duct.

**Figure 7 — Dust feeder assembly — Critical dimensions**

Dimensions in millimetres

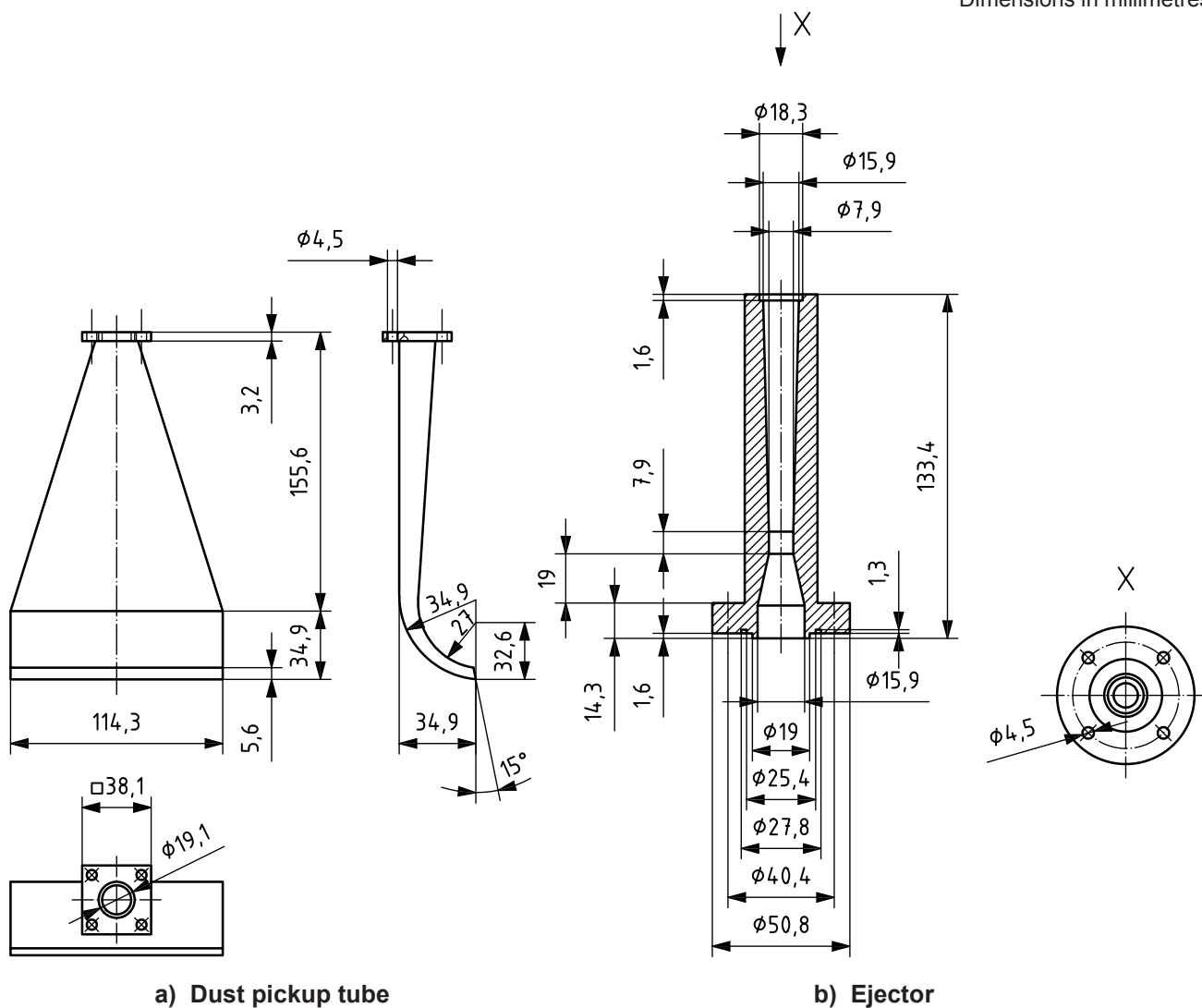

Tolerances: for integers  $\pm 0,8$  mm  
 for decimals  $\pm 0,03$  mm

Figure 8 — Ejector, Venturi ejector and pickup details for the dust feeder



## 7 Qualification of test rig and apparatus

### 7.1 General

A summary of the qualification requirements and frequency of maintenance is given in 7.15 and 7.16.

### 7.2 Air velocity uniformity in the test duct

The uniformity of the air velocity in the test duct shall be determined by measuring the velocity at nine points, located as in Figure 9, immediately upstream of the test filter section, without the test filter and the mixing device. Measurements shall be made using an instrument having an accuracy of  $\pm 10\%$  and a minimum resolution of 0,05 m/s (10 ft/min).

Measurements shall be conducted at 0,25 m<sup>3</sup>/s (530 ft<sup>3</sup>/min), 0,944 m<sup>3</sup>/s (2 000 ft<sup>3</sup>/min) and 1,5 m<sup>3</sup>/s (3 178 ft<sup>3</sup>/min). It is important that no significant disturbance of the air flow occur — from instrument, operator, etc. — when measuring the velocities.

For each measurement, a sample time of at least 15 s shall be used. An average of three measurements shall be calculated for each of the nine points and the mean and the standard deviation calculated from these nine values.

The coefficient of variation,  $C_V$ , shall be calculated as follows:

$$C_V = \frac{\delta}{v_{\text{mean}}} \quad (1)$$

where

$\delta$  is the standard deviation of the nine measuring points;

$v_{\text{mean}}$  is the velocity mean value of the nine measuring points.

$C_V$  shall be less than 10 % at each air flow.

Dimensions in millimetres

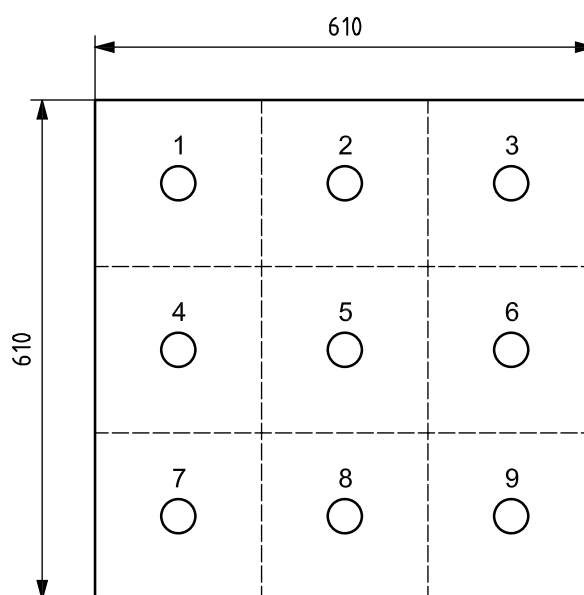

**Figure 9 — Air velocity and aerosol uniformity —  
 Sampling points for measuring uniformity of air velocity and aerosol dispersion**

### 7.3 Aerosol uniformity in the test duct

The uniformity of the challenge aerosol (DEHS and KCl) in the test duct shall be determined by measurements at nine points immediately upstream of the filter (see Figure 9). The mixing device should be removed during qualification testing. The measurement can be carried out using a single probe that can be repositioned. The probe shall be of the same shape as the probe used in the efficiency test and have an appropriate entrance diameter to obtain isokinetic sampling within 10 % at 0,944 m<sup>3</sup>/s (2 000 ft<sup>3</sup>/min). The same probe and sample flow shall be used at test duct flows of 0,25 m<sup>3</sup>/s (530 ft<sup>3</sup>/min), 0,944 m<sup>3</sup>/s (2 000 ft<sup>3</sup>/min) and 1,5 m<sup>3</sup>/s (3 178 ft<sup>3</sup>/min). The sampling line shall be as short as possible so as to minimize sampling losses and shall also be of the same diameter as the one used in the efficiency test.

The aerosol concentration shall be measured with a particle counter meeting the requirements of this Technical Specification. The number of particles counted in all specified size ranges in a single measurement should be greater than 500 in order to reduce the statistical error.

Take a sample successively at each measuring point. Repeat this procedure until five samples from each measuring point are obtained. Average the five values for each point for all size ranges of the particle counter and calculate the coefficient of variation for each for size range  $i$ , as follows:

The coefficient of variation,  $C_{Vi}$ , shall be calculated as follows:

$$C_{Vi} = \frac{\delta_i}{C_{\text{mean},i}} \quad (2)$$

where

$\delta_i$  is the standard deviation of the nine measuring points for size range  $i$ ;

$C_{\text{mean},i}$  is the mean value of the nine measuring points for size range  $i$ .

$C_{Vi}$  shall be less than 15 % for 0,25 m<sup>3</sup>/s (530 ft<sup>3</sup>/min), 0,944 m<sup>3</sup>/s (2 000 ft<sup>3</sup>/min) and 1,5 m<sup>3</sup>/s (3 178 ft<sup>3</sup>/min).

### 7.4 Particle counter sizing accuracy

Optical particle counters (OPCs) measure the particle concentration and the equivalent optical particle size. The indicated particle size is strongly dependent on the calibration of the OPC.

To avoid effects caused by different aerodynamic, optical and electronic systems of various types of OPC, measurements both upstream and downstream of the filter shall be made using either one instrument or two identical instruments.

The OPC shall be calibrated prior to initial system start-up and thereafter at regular intervals of not longer than one year and shall have a valid calibration certificate. The calibration of the OPC shall be carried out by the OPC manufacturer or any similarly qualified organization according to established standardized procedures (see, for example, ISO 21501-4, ISO 21501-1, IEST-RP-CC014, ASTM-F328 or ASTM-F649) with polystyrene microspheres (PSL) in single dispersion, having a refractive index of 1,59. The calibration shall be performed on at least three channels of the OPC in each of the two measuring ranges 0,3 µm to 1,2 µm and 1 µm to 5,5 µm.

The first size range, 0,3 µm to 1,2 µm, shall include the channels containing 0,3 µm and 1 µm, and the second size range, 1 µm to 5,5 µm, shall include the channels containing 1 µm and 5 µm. One counter for each size range can be used or one counter for both size ranges.

It is good practice to check the sizing accuracy of the particle counter on a regular basis, such as at the start of every working day. This quick calibration check will help the operator discover potential measurement problems prior to running the filter test. By generating an aerosol of a known size of polystyrene microspheres and verifying that these particles appear in the corresponding size class(es) of the OPC, the user can quickly verify the accuracy of the sizing capabilities of the equipment. Checks with polystyrene microspheres at the low and high ends of the particle size range(s) are especially meaningful.

The sampling air flow of the OPC shall be calibrated to be within  $\pm 5\%$  of the OPC's rated air flow, in compliance with a single established standardized procedure (e.g. IEST-RP-CC014).

### 7.5 Particle counter zero test

The count rate shall be verified as having less than 10 total counts per minute in the 0,3  $\mu\text{m}$  to 5,5  $\mu\text{m}$  size range when operating using a high-efficiency filter ( $> 99,97\%$  of 0,3  $\mu\text{m}$  particles) directly attached to the sampling nozzle inlet. This also includes the sampling system.

### 7.6 Particle counter overload test

OPC can underestimate particle concentrations if their concentration limit (CL) is exceeded. Therefore, it is necessary to know the CL of the OPC being used. The maximum aerosol concentration used in the tests should then be kept sufficiently below the CL so that the counting error resulting from coincidence does not exceed 5%. The operation of OPC above their CL will cause efficiency results to be lower than in reality.

If the upstream concentration in the test duct cannot be reduced, a dilution system may be used to reduce the aerosol concentrations to below the OPC's CL. It is then necessary to take upstream and downstream samples via the dilution system in order to eliminate errors arising from uncertainty in the dilution factor's value.

Either one or the other of the following two procedures may be used to determine whether the data values are influenced by coincidence errors. Procedure b) is the more reliable of the two options and is therefore the recommended procedure.

- a) The efficiency of a reference filter shall be measured at different concentrations. At a concentration above the OPC's CL, efficiency starts to decrease.
- b) An upstream particle concentration distribution shall be measured. Afterward, the concentration shall be uniformly reduced or diluted (this can be done by a known or an unknown factor) and the measurement of the particle concentration distribution repeated. If the shape of the latter particle size distribution curve shifts towards smaller particles, this is a clear sign that the former concentration was higher than the OPC's CL. If the factor for concentration reduction or dilution is known, this factor should be found in each size class of the OPC, between the two concentration measurements.

Concentration reduction can be achieved by reducing the aerosol generator's output. Concentration dilution can be achieved by a dilution system in the sampling line of the OPC.

### 7.7 100 % efficiency test

The purpose of this test is to ensure that the test duct and sampling system are capable of providing a 100% efficiency measurement. The test shall be made using a high-efficiency filter as the test device, using the normal test procedure for determination of efficiency. The test shall be performed at an air flow of 0,944  $\text{m}^3/\text{s}$  (2 000  $\text{ft}^3/\text{min}$ ). The efficiency shall be greater than 99% for all particle sizes.

### 7.8 Zero % efficiency test

The zero % efficiency test is a test of the accuracy of the overall duct, sampling, measurement and aerosol generation systems. The test shall be performed as a normal efficiency test but without a test filter installed. The test air flow shall be 0,944  $\text{m}^3/\text{s}$  (2 000  $\text{ft}^3/\text{min}$ ). Two tests shall be performed according to standard test procedure and the calculated zero efficiency shall meet the following criteria:

- $(0 \pm 3)\%$  for particle sizes  $\leq 1,0 \mu\text{m}$ ;
- $(0 \pm 7)\%$  for particle sizes  $> 1,0 \mu\text{m}$ .

The total number of counted particles for each size shall be greater than 500 in order to limit the statistical error.

## 7.9 Aerosol generator response time

To ensure that sufficient time is allowed for the concentration to stabilize before performing any tests, measure the time taken for the aerosol concentration to go from background level to steady-state test level.

Start the aerosol generator and record the time interval for the concentration to stabilize to a steady-state condition. The time interval shall be used as a minimum delay time before starting a test sequence according to this Technical Specification.

## 7.10 Correlation ratio

The correlation ratio,  $R$ , shall be used to correct for any bias between the upstream and downstream sampling systems. If the zero % efficiency test fails but the correlation ratio limits are within the requirements set out in 7.15, the correlation ratio correction shall be used to continue the test. If efficiency is outside the limits, the test shall not be allowed.

The correlation ratio shall be established from the ratio of downstream to upstream particle counts without the test device installed in the test duct and before testing an air cleaner. The test shall be performed at the airflow rate of the test filter. The general equation for  $R$  as used in this Technical Specification is

$$R = \frac{N_d}{N_u} \quad (3)$$

where

$N_d$  is the number of particles downstream of the filter;

$N_u$  is the number of particles upstream of the filter.

The particle generator shall be on, but without a test device in place. Upstream and downstream sampling times shall be the same during this test. The aerosol used shall be the same as the aerosol to be used to test the filters (DEHS or KCl). The data from the zero efficiency test may be used for this calculation.

Calculate the average upstream count,  $\overline{N_u}$ , and average downstream count,  $\overline{N_d}$ , for each particle size channel  $i$ :

$$\overline{N_u} = \frac{\sum_{i=1 \rightarrow n} N_{u,i}}{N} \quad (4)$$

$$\overline{N_d} = \frac{\sum_{i=1 \rightarrow n} N_{d,i}}{N}$$

where  $N$  is the number of points. Then calculate the correlation ratio for each particle size channel  $i$ :

$$R_i = \frac{\overline{N_d}}{\overline{N_u}} \quad (5)$$

## 7.11 Pressure drop checking

All equipment for pressure drop readings shall meet the requirements given in 7.15.

This test is used to verify that leaks in the equipment for pressure drop readings, instrument lines, etc. do not significantly affect the accuracy of the measurements of air flow or pressure drop. The test may be made by calibrated devices or by the system specified below.

Seal the pressure sample points in the test duct carefully. Disconnect the pressure drop meter. Pressurize the tubes with a constant negative pressure of 5 000 Pa (20 in WG). Check all sampling lines in this manner (see Figure 10). No changes in pressure are allowed.

Pressurize the pressure drop measuring equipment at the maximum permitted pressure according to the instrument specification. The procedure shall be carried out sequentially on both positive and negative pressure lines. No changes in pressure are permitted on either inlet.

Additionally, a perforated plate (or other reference) having known pressure drops at 0,5 m<sup>3</sup>/s, 0,75 m<sup>3</sup>/s, 0,944 m<sup>3</sup>/s and 1,5 m<sup>3</sup>/s (1 060 ft<sup>3</sup>/min, 1 590 ft<sup>3</sup>/min, 2 000 ft<sup>3</sup>/min and 3 178 ft<sup>3</sup>/min) may be used for periodic checks on the pressure drop measurement system.

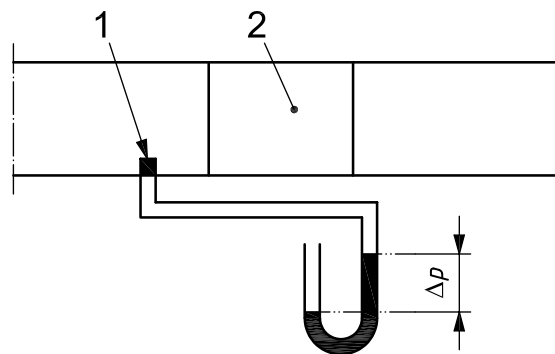

**Key**

- 1 sealed pressure inlet
- 2 test device section
- $\Delta p$  5 000 Pa

**Figure 10 — Pressure line test**

**7.12 Dust feeder air flow rate**

The purpose of this test is to verify that the air flow rate for the dust feeder is correct.

The aspirator Venturi is subject to wear from the dust and compressed air and will thereby become enlarged. It is therefore important periodically to monitor the air flow rate from the dust feeder. The flow shall be  $(6,8 \times 10^{-3}) \text{ m}^3/\text{s} \pm (0,24 \times 10^{-3}) \text{ m}^3/\text{s}$  ( $14,5 \text{ ft}^3/\text{min} \pm 0,5 \text{ ft}^3/\text{min}$ ). This air flow is determined as shown in Figure 11.

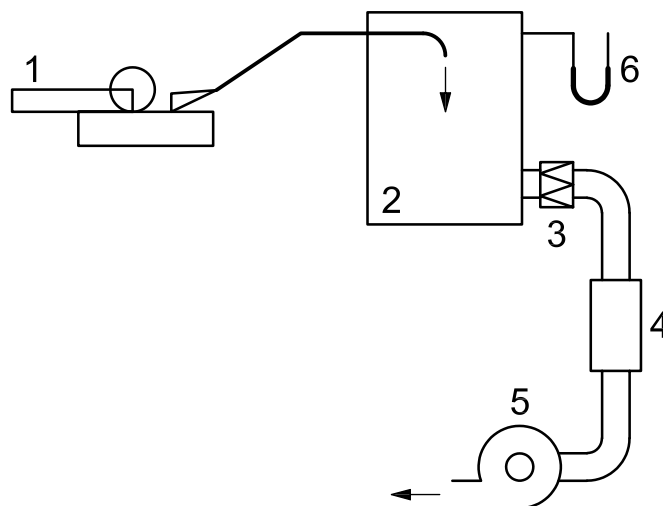

**Key**

- 1 dust feeder
- 2 plenum with minimum volume of 0,25 m<sup>3</sup> (8,8 ft<sup>3</sup>)
- 3 high-efficiency filter (minimum 99,97 % at 0,3 μm)
- 4 flow metering device
- 5 fan
- 6 pressure drop measurement device<sup>a</sup>

<sup>a</sup> The differential pressure should be zero.

**Figure 11 — Dust feeder air flow rate**

### 7.13 Reference filter check

For each test duct a minimum of three identical reference filters shall be maintained by the testing facility solely for initial efficiency testing on a bi-weekly basis; these filters shall not be exposed to dust loading. The three filters shall be labelled “primary”, “secondary” and “reserve”. The primary filter shall be checked every two weeks. If the filtration efficiency values shift by more than five percentage points for any of the particle sizing channels, the secondary filter shall be tested. If both primary and secondary filters show shifts of more than five percentage points for any of the particle sizing channels, the particle counter shall be recalibrated or other system maintenance performed as needed (e.g. clean sample lines) to restore the reference filter efficiency test so that a less than 5 percentage point shift occurs. The reserve filter shall be used if either the primary or secondary filter becomes unusable (e.g. damaged).

The measured pressure drop across the reference filter shall be within 10 % of the reference value. If the pressure drop deviates by more than 10 %, system maintenance shall be performed to restore the pressure drop to be within 10 % of the reference value.

The reference filter tests shall be performed at 0,944 m<sup>3</sup>/s (2 000 ft<sup>3</sup>/min) and the efficiency of the reference filter shall have an approximately 20 %, 50 % and 90 % efficiency for 0,4 μm, 1 μm and 3 μm particles respectively.

Immediately after calibration of the particle counter, retest each of the reference filters (or a new set of filters) to establish new filtration efficiency and pressure drop reference values.

When either the primary or secondary filtration efficiency values shift by more than five percentage points for any of the particle sizing channels, and either the secondary or reserve filter does not, the primary and/or secondary filter shall be replaced with an identical filter or filters; if available, a new set of identical filters shall be obtained.

### 7.14 Activity of the aerosol neutralizer

The activity of the radiation source within the aerosol neutralizer shall be confirmed by use of an appropriate radiation detection device. The measurement may be relative (as opposed to absolute) but shall be adequate to indicate the presence of an active source and shall be capable of being performed in a repeatable manner.

The measurement shall be repeated annually and compared to prior measurements to determine if a decrease in activity has occurred. Replace neutralizers showing a lack of activity in accordance with the manufacturers' recommendations.

The corona discharge level shall be high enough to meet the same neutralizing level as from the radioactive source described in 6.4.

### 7.15 Summary of qualification requirements

See Table 2.

**Table 2 — Summary of qualification requirements**

| Parameter                           | Subclause | Requirement  |
|-------------------------------------|-----------|--|
| Air velocity uniformity             | 7.2       | $C_V$ (coefficient of variation) < 10 %  |
| Aerosol uniformity                  | 7.3       | $C_V$ (coefficient of variation) < 15 %  |
| Particle counter sizing accuracy    | 7.4       | According to manufacturer's valid calibration certificate  |
| Particle counter — overload test    | 7.6       | No overloading   |
| Particle counter zero test          | 7.5       | < 10 counts per minute in size range 0,2 µm to 5 µm  |
| 100 % efficiency test               | 7.7       | > 99 %   |
| Zero % efficiency test              | 7.8       | Sizes: ≤ 1,0 µm: ± 3 %<br>> 1,0 µm: ± 7 %  |
| Correlation ratio                   | 7.10      | Sizes: > 0,3 to 1,0 µm: ± 10 %<br>> 1,0 to 3,0 µm: ± 20 %<br>> 3,0 µm: ± 30 %  |
| Aerosol generator response time     | 7.9       | As measured.   |
| Manometer calibration               | 7.11      | Size range: (0 Pa to 70 Pa) ± 2 Pa<br>[(0 to 0,28 in WG) ± 0,01 in WG]<br>> 70 Pa (0,28 in WG) ± 3 % of measured value                           |
| Pressure drop test                  | 7.11      | No detectable leaks.   |
| Dust feeder air flow rate           | 7.12      | $6,8 \times 10^{-3} \text{ m}^3/\text{s} \pm 0,24 \times 10^{-3} \text{ m}^3/\text{s}$<br>(14,5 ft <sup>3</sup> /min ± 0,5 ft <sup>3</sup> /min) |
| Reference filter check              | 7.13      | < 10 % shift in efficiency in each size channel  |
| Activity of the aerosol neutralizer | 7.14      | As specified by the manufacturer   |

## 7.16 Apparatus maintenance

See Table 3.

Table 3 — Frequency of maintenance

| Maintenance item   | Subclause | Daily          | Monthly         | Bi-annually | Annually | After any change that might alter performance |
|--|-----------|----------------|-----------------|-------------|----------|---|
| <b>Test duct</b>   |           |                |                 |             |          |   |
| Air velocity uniformity  | 7.2       |                |                 |             |          | ×   |
| Aerosol uniformity   | 7.3       |                |                 |             |          | ×   |
| 100 % efficiency test  | 7.7       |                | ×               |             |          | ×   |
| Zero % efficiency test   | 7.8       | ×              |                 |             |          | ×   |
| Pressure drop test   | 7.11      |                |                 | ×           |          | ×   |
| <b>Instrument</b>  |           |                |                 |             |          |   |
| Aerosol generator response time  | 7.9       |                |                 | ×           |          | ×   |
| Manometer calibration  | 7.11      |                |                 |             | ×        | ×   |
| Particle counter — sizing accuracy   | 7.4       | × <sup>a</sup> |                 |             | ×        | ×   |
| Particle counter — overload test   | 7.6       |                |                 |             |          | ×   |
| Particle counter — zero test   | 7.5       | ×              |                 |             |          | ×   |
| Dust feeder air flow rate  | 7.12      |                |                 | ×           |          | ×   |
| Reference filter check   | 7.13      |                | Every two weeks |             |          | ×   |
| Activity of the aerosol neutralizer  | 7.14      |                |                 |             | ×        | ×   |
| Regular cleaning of all equipment should be undertaken to maintain test system performance.  |           |                |                 |             |          |   |
| <sup>a</sup> It is good practice to check the sizing accuracy of the particle counter on a regular basis, such as at the start of every day or a new test. This quick calibration check will help the operator discover potential measurement problems prior to running the filter test. By generating an aerosol of a known size of polystyrene microspheres and verifying that these particles appear in the corresponding size class(es) of the OPC(s) the user can quickly verify the accuracy of the sizing capabilities of the equipment. Checks with polystyrene microspheres at the low and high ends of the particle size range(s) are especially meaningful. |           |                |                 |             |          |   |

## 8 Test materials

### 8.1 Test air

Room air or outdoor air may be used as the test air source. In the efficiency tests the air is filtered with high-efficiency filters to obtain a test air free of background particles. The test conditions shall be in accordance with 6.1. The exhaust flow may be discharged outdoors, indoors or recirculated. Filtration of the exhaust flow is recommended when test aerosol and loading dust could be present.

The compressed air for the dust feeder shall be dry, clean and free from oil.

### 8.2 Test aerosol

Filters with 0,4 µm initial efficiency and/or conditioned efficiency  $\geq 20\%$  on DEHS particles shall be tested against DEHS particles from 0,3 µm to 1,2 µm, while filters with an initial efficiency of less than 20 % shall be tested against KCl particles in the size range 1 µm to 5,5 µm.



## 8.2.1 DEHS test aerosol

### 8.2.1.1 General

Test liquid aerosol of DEHS produced by a Laskin nozzle arrangement is widely used in the testing of high-efficiency filters. DEHS is the same as DES Di(2-ethylhexyl) Sebacate or Bis (2-ethylhexyl) Sebacate.

The DEHS aerosol shall be used untreated and introduced directly into the test rig. The aerodynamic, geometric and light scattering sizes are close to each other when measured with OPC.

### 8.2.1.2 DEHS/DES/DOS — Formula

The chemical formula is the following:



### 8.2.1.3 DEHS properties

The DEHS properties are as follows:

|                                 |   |
|---------------------------------|---|
| Density                         | 912 kg/m <sup>3</sup> (57 lb/ft <sup>3</sup> )                              |
| Melting point                   | 225 K   |
| Boiling point                   | 529 K   |
| Flash point                     | > 473 K   |
| Vapour pressure                 | 1,9 μPa (1,9 × 10 <sup>-6</sup> Pa) (7,6 × 10 <sup>-9</sup> in WG) at 273 K |
| Refractive index                | 1,450 at 600 N·m wavelength   |
| Dynamic viscosity               | 0,022 Pa·s (0,015 lb/ft·s) to 0,024 Pa·s (0,016 lb/ft·s)                    |
| CAS (chemical abstracts) number | 122-62-3  |

The test aerosol of PAO [Polyalphaolefins (CAS number 68649-12-7)] produced by a Laskin nozzle arrangement is also used for testing of high-efficiency filters and can be used as an alternative to DEHS (see ISO 14644-3, JIS Z 8901 or JACA No. 37-2001).

## 8.2.2 KCl test aerosol

The KCl test aerosol shall be solid-phase potassium chloride particles generated from an aqueous solution by air atomizing spray nozzles according to 6.4.

The aerodynamic, geometric and light scattering sizes differ from one another when measured with optical particle counters.

## 8.3 Loading dust

### 8.3.1 General

Two types of loading dust are used: fine test dust according to ISO 12103-1, for loading of filters using the fine dust method (9.6.1), and ASHRAE dust for the filters tested by the coarse method (9.6.2).

### 8.3.2 Fine loading dust (ISO 12103-A2)

The loading test dust classified as *fine* according to ISO 12103-1, identified as ISO 12103-A2, consists mainly of silica particles with the size distribution given in Table 4.

Table 4 — Size distribution of ISO 12103-A2 loading dust

| Size<br>µm | Volume larger than size<br>% |
|------------|------------------------------|
| 1          | 96,5 to 97,5                 |
| 2          | 87,5 to 89,5                 |
| 3          | 78,0 to 81,5                 |
| 4          | 70,5 to 74,5                 |
| 5          | 64 to 69                     |
| 7          | 54 to 59                     |
| 10         | 46 to 50                     |
| 20         | 26 to 30                     |
| 40         | 9 to 12                      |
| 80         | 0 to 0,5                     |

### 8.3.3 ASHRAE loading dust

The ASHRAE 52.2 test dust used as the loading dust for the coarse dust method is of the following composition:

- 72 % by mass test dust, fine, ISO 12103-A2 (see Table 4);
- 23 % by mass carbon black;
- 5 % by mass cotton linters.

## 8.4 Final filter

The final filter, which captures any loading dust that passes through the tested filter during the dust loading procedure, shall have an initial efficiency of > 75 % with respect to 0,4 µm DEHS particles and shall not gain or lose more than one gram as a result, for example, of humidity variations met during a test cycle.

## 9 Test procedure

### 9.1 General

This clause describes the sampling sequence and data analysis procedures for sequential upstream-downstream sampling with one particle counter. The same procedures apply for dual-particle counter systems with simultaneous upstream-downstream sampling. The data quality requirements for both single- and dual-particle counter systems are identical.

Two alternative test procedures are specified. The selection of one or the other depends on the initial efficiency of the filters and the conditioned efficiency of their media, viz.:

- filters for which both the complete filter and the conditioned medium have an efficiency greater than 20 % with respect to 0,4  $\mu\text{m}$  DEHS particles shall be tested using the *fine* method (9.6.1);
- filters failing either of the above criteria shall be tested using the *coarse* method (9.6.2).

See Table 5.

**Table 5 — Overview of test procedure and comparison of methods**

| Test method | Size range<br>$\mu\text{m}$ | Test aerosol    | Conditioning | Loading dust in one step  | Final test pressure drop,<br>Pa (in WG) |
|-------------|-----------------------------|-----------------|--------------|---|---|
| Fine        | 0,3 to 1,2                  | Untreated DEHS  | Yes          | ISO 12103-A2 (140 mg/m <sup>3</sup> )<br>(4,0 g/1 000 ft <sup>3</sup> ) | 375 (1,5)                               |
| Coarse      | 1,0 to 5,5                  | Neutralized KCl | Yes          | ASHRAE (70 mg/m <sup>3</sup> )<br>(2,0 g/1 000 ft <sup>3</sup> )        | 250 (1,0)                               |

## 9.2 Preparation of filter to be tested

The filter shall be mounted in accordance with the manufacturer's recommendations and, after equilibration with the test air, weighed to the nearest gram. Devices requiring external accessories shall be operated during the test with accessories having characteristics equivalent to those used in actual practice. The filter, including any normal mounting frame, shall be sealed into the duct in a manner that prevents leakage. The tightness shall be checked by visual inspection and no visible leaks shall be accepted. If, for any reason, dimensions do not allow testing of a filter under standard test conditions, the assembly of two or more filters of the same type or model is permitted, provided no leaks occur in the resulting filter. The operating conditions of such accessory equipment shall be recorded.

## 9.3 Initial pressure drop

The value of the initial pressure drop shall be recorded at 50 %, 75 %, 100 % and 125 % of the rated air flow to establish a curve of pressure drop as a function of the air flow rate. The air flow is reported as measured under the local conditions. If the air density is not between 1,16 kg/m<sup>3</sup> (0,072 4 lb/ft<sup>3</sup>) and 1,24 kg/m<sup>3</sup> (0,077 4 lb/ft<sup>3</sup>), then the pressure drop readings shall be corrected to an air density of 1,20 kg/m<sup>3</sup> (0,075 lb/ft<sup>3</sup>) in accordance with Annex D. This corresponds to standard air conditions: temperature 20 °C (68 °F), barometric pressure 101,3 kPa (14,6 lbf/in<sup>2</sup>) and relative humidity 50 %.

## 9.4 Initial efficiency measurement

### 9.4.1 General

The initial efficiency of a new untreated filter shall be tested at rated air flow, with the efficiency being measured according to 9.4.2 for DEHS test aerosol in the size range 0,3  $\mu\text{m}$  to 1,2  $\mu\text{m}$ .

Filters with an initial efficiency greater than or equal to 20 % of 0,4  $\mu\text{m}$  DEHS particles shall then be tested using the conditioning test given in 9.5 and dust loaded using the fine method specified in 9.6.1.

Filters that are known to have an initial efficiency of less than 20 % may progress directly to the KCl (1  $\mu\text{m}$  to 5,5  $\mu\text{m}$ ) efficiency and conditioning tests, which shall be performed in accordance with 9.4.2 and 9.5 respectively.

See Table 5 for an overview of the test procedures.

All filters tested using either the fine or the coarse method shall be tested in accordance with 9.5.

### 9.4.2 Efficiency test

The zero % efficiency test according to 7.8 shall be performed daily or before the start of testing.

The method is the same for filters tested against DEHS particles in the size range 0,3 µm to 1,2 µm or KCl aerosol in the size range 1 µm to 5,5 µm.

If the zero % efficiency test fails and the limits are within the requirements given in 7.15, the correlation ratio correction shall be used to continue the test. If the efficiency is outside the limits, the test shall not be accepted.

The efficiency,  $E$ , for a given particle size range (between two particle diameters) shall be calculated as follows:

$$E = 1 - \frac{N_d}{N_u R} \quad (6)$$

where

$R$  is the correlation ratio according to 7.10;

$N_d$  is the number of particles in size range  $i$ , downstream of filter;

$N_u$  is the number of particles in size range  $i$ , upstream of filter.

The initial efficiency data versus the size range diameters shall be presented in a table. A graph may also be added if required, which shall have its  $x$ -axis in logarithmic scale and its  $y$ -axis covering the 0 % to 100% range. The size range diameter or the mean diameter,  $d_i$ , is the geometric average of the lower and upper border diameters in size range  $i$ :

$$d_i = \sqrt{d_l \times d_u} \quad (7)$$

where

$d_l$  is the lower border diameter in the size range;

$d_u$  is the upper border diameter in the size range.

The aerosol generator output is adjusted to generate a stable concentration of aerosol within the OPC coincidence level requirements and so that the downstream count rate is sufficient for a statistically valid result within an acceptable time scale.

The efficiency measurement is made by a series of at least 13 counts of minimum 20 s, conducted successively upstream and downstream of the filter under test and with a purge before each count, or with one intervening sample upstream or downstream without counting, in order to stabilize the concentration of particles in the transfer lines.

The counting cycle for size range  $i$  will then be as in Table 6.

**Table 6 — Counting cycle for size range  $i$**

| Count no.  | 1          | 2          | 3          | 4          | 5          | 6          | 7          | 8          | 9          | 10         | 11         | 12         | 13         |
|------------|------------|------------|------------|------------|------------|------------|------------|------------|------------|------------|------------|------------|------------|
| Upstream   | $N_{u1,i}$ |            | $N_{u2,i}$ |            | $N_{u3,i}$ |            | $N_{u4,i}$ |            | $N_{u5,i}$ |            | $N_{u6,i}$ |            | $N_{u7,i}$ |
| Downstream |            | $N_{d1,i}$ |            | $N_{d2,i}$ |            | $N_{d3,i}$ |            | $N_{d4,i}$ |            | $N_{d5,i}$ |            | $N_{d6,i}$ |            |

The first single efficiency,  $E_{1,i}$ , for size range  $i$  shall be calculated as follows:

$$E_{1,i} = 1 - \frac{N_{d1,i}}{\frac{(N_{u1,i} + N_{u2,i})R_i}{2}} \quad (8)$$

where  $R_i$  is the correlation ratio for size range  $i$  according to 7.10.

The 13 measurements give six single efficiency ( $E_{1,i}, \dots, E_{6,i}$ ) results. The average efficiency,  $\overline{E}_i$ , shall be calculated for the size range  $i$  as follows:

$$\overline{E}_i = \frac{(E_{1,i} + \dots + E_{6,i})}{6} \quad (9)$$

## 9.5 Conditioning test

Separate media (samples) of the same identity as the media in the filter used for the main test shall be tested according to Annex A. Filters found to have an initial 0,4  $\mu\text{m}$  DEHS efficiency of less than 20 % shall be efficiency tested against the KCl test aerosol (1  $\mu\text{m}$  to 5,5  $\mu\text{m}$ ). Filters with an initial efficiency and conditioned efficiency equal to or greater than 20 % with respect to 0,4  $\mu\text{m}$  DEHS particles shall be tested against DEHS in the size range 0,3  $\mu\text{m}$  to 1,2  $\mu\text{m}$ .

## 9.6 Dust loading

### 9.6.1 Fine method

Filters with a 0,4  $\mu\text{m}$  initial efficiency and conditioned efficiency greater than or equal to 20 % of DEHS particles shall be tested using this method.

- Having measured initial DEHS efficiencies from 0,3  $\mu\text{m}$  to 1,2  $\mu\text{m}$  for filters in accordance with 9.4.2, measure the conditioned efficiency in accordance with Annex A using DEHS aerosol in the range 0,3  $\mu\text{m}$  to 1,2  $\mu\text{m}$  for the media.
- Perform one-step loading with ISO 12103-A2 dust (140  $\text{mg}/\text{m}^3$ ) (4,0  $\text{g}/1000 \text{ft}^3$ ) up to a 375 Pa (1,5 in WG) final test pressure drop using the loading procedure specified in 9.6.3 for the filter.
- Retest DEHS efficiency after dust loading (loaded DEHS efficiency) as specified in 9.6.4 for the filter.

### 9.6.2 Coarse method

Filters with 0,4  $\mu\text{m}$  initial DEHS efficiency and/or conditioned DEHS efficiency of less than 20 % shall be tested using this method.

- Having tested the initial KCl efficiency from 1  $\mu\text{m}$  to 5,5  $\mu\text{m}$  in accordance with 9.4.2 for the filter, carry out the conditioning test in accordance with Annex A using KCl aerosol in the range 1  $\mu\text{m}$  to 5,5  $\mu\text{m}$  for the media.
- Perform one-step loading using ASHRAE dust [70  $\text{mg}/\text{m}^3$ ] (2,0  $\text{g}/1000 \text{ft}^3$ ) up to a 250 Pa (1,0 in WG) final test pressure drop using the loading procedure specified in 9.6.3 for the filter.
- Retest KCl efficiency after dust loading (loaded KCl efficiency) as specified in 9.6.4 for the filter.

### 9.6.3 Loading procedure

The test rig shall have a final filter installed that is weighed prior to starting the test. Progressively load the test filter with the standardized test dust (ISO or ASHRAE dust). Weigh dust increments to  $\pm 0,1$  g and place in the dust tray. Feed the ASHRAE dust to the filter at a concentration of  $70 \text{ mg/m}^3$  ( $2,0 \text{ g/1 000 ft}^3$ ) and the ISO 12103-A dust at a concentration of  $140 \text{ mg/m}^3$  ( $4,0 \text{ g/1 000 ft}^3$ ) until a final test pressure drop is attained. Reduce the concentration if the recommended final test pressure drop is exceeded. Necessary stops are allowed (over night, etc.).

Before stopping the dust feeding, brush whatever dust remains in the feeder tray into the dust pickup tube so that it is entrained in the duct air flow. Vibrate or rap the dust feeder tube for 30 s. The dust fed to the filter may also be estimated by weighing the remaining dust in the feeder. With the test air flow on, re-entrain any synthetic dust in the duct upstream of the filter by the use of a compressed air jet directed obliquely away from the tested filter.

After reaching the final test pressure drop, stop the test and reweigh the final filter (to at least 0,5 g accuracy) to determine the amount of synthetic dust collected and calculate the arrestance. Any dust deposited in the duct between the filter and the final filter should be collected with a fine brush and included in the final filter mass. The mass increase indicates the mass of dust that has passed the test filter. Calculate the average arrestance,  $A_m$ , during the dust loading as follows:

$$A_m = \left( \frac{1 - m}{m_{\text{tot}}} \right) 100 \% \quad (10)$$

where

$m$  is the mass of dust passing the filter (the mass gain of the final filter and the dust in the duct between the filter and the final filter) up to the final test pressure drop;

$m_{\text{tot}}$  is the total mass of dust fed during the dust loading.

The TDC for the final test pressure drop is the difference between  $m_{\text{tot}}$  and  $m$ .

### 9.6.4 Loaded efficiency

The loaded efficiency shall be determined after dust loading the test filter to the final test pressure drop:

- DEHS test aerosol in the size range  $0,3 \mu\text{m}$  to  $1,2 \mu\text{m}$  and a 375 Pa (1,5 in WG) final test pressure drop for filters tested according to the fine method;
- KCl test aerosol in the size range  $1 \mu\text{m}$  to  $5,5 \mu\text{m}$  and a 250 Pa (1,0 in WG) final test pressure drop for filters tested according to the coarse method.

Especially after dust loadings there could be a release of particles (shedding of particles) downstream of the filter that will influence efficiency. To adjust for that dust migration, the air flow shall be maintained through the device for 20 min before testing the efficiency, or for less than 20 min if a re-entrainment of no more than 5 % is obtained in each of the particle size ranges.

At a re-entrainment of more than 5 %, adjust the efficiency by subtracting the released particles from the downstream count, noting in the test report that the efficiency has been adjusted for release of particles (high concentrations upstream will reduce the need for this).

Perform the efficiency measurement in accordance with 9.4.2.

## 10 Uncertainty calculation of the test results

The uncertainty on the average efficiency as defined corresponds to a two-sided confidence interval of the average value based on a 95 % confidence level. An upstream sample of no less than 500 particles shall be counted in evaluated size ranges up to 5 µm, in accordance with ISO 2854, as follows:

$$\overline{E}_i - U \leq \overline{E}_i \leq \overline{E}_i + U \quad (11)$$

$$\overline{E}_i = \frac{1}{N} \sum E \quad (12)$$

$$U = t_{\left(1-\frac{\alpha}{\sqrt{2}}\right)} \times \frac{\delta}{\sqrt{n}} \quad (13)$$

$$\nu = N - 1 \quad (14)$$

$$\delta = \sqrt{\frac{\sum (E - \overline{E}_i)^2}{N - 1}} \quad (15)$$

where

$\overline{E}_i$  is the average efficiency in size range  $i$ ;

$U$  is the uncertainty;

$E$  is the calculated single value of the efficiency in size range  $i$  ( $E_1, E_2, \dots$ ; see 9.4.2);

$\nu$  is the number of degrees of freedom;

$t_{\left(1-\frac{\alpha}{\sqrt{2}}\right)}$  is the Student's distribution, depending on the number of degrees of freedom,  $\nu$  (see Table 7);

$N$  is the number of calculated single efficiency values,  $E_i$ ;

$\delta$  is the standard deviation.

The uncertainty is calculated for each size range  $i$ . See Table 7.

**Table 7 — Student's distribution according to ISO 2854**

| Samples                                    | Number of degrees of freedom | Uncertainty  |
|--|------------------------------|--|
| $N$  | $\nu = N - 1$                | $t_{\left(1-\frac{\alpha}{\sqrt{2}}\right)} \times \frac{1}{\sqrt{N}}$ |
| 4  | 3                            | 1,591  |
| 5  | 4                            | 1,242  |
| 6  | 5                            | 1,049  |
| 7  | 6                            | 0,925  |
| 8  | 7                            | 0,836  |
| 95 % confidence level ( $\alpha = 0,05$ ). |                              |  |

## 11 Test report

### 11.1 General

The test report shall include an explanation of the test results and a description of the test method and any deviations from it. The type and identification number of the particle counter used should be reported, as well as the method of air flow rate measurement. The report shall include the following:

- a) the interpretation of test reports, as detailed in 11.2;
- b) a summary of the results;
- c) measured efficiencies and their uncertainties;
- d) data and results of air flow rate and test pressure drop measurements.

The test results shall be reported using the sample report format presented in Figures 12 and 13 and Tables 8 to 12. These comprise the complete test report and are examples of acceptable presentation. The format of the actual test report need not be the same, but the actual report shall include all the items included in the sample test report. The legend of each table and graph should also include the following:

- type of filter;
- the number of this Technical Specification;
- test number;
- test aerosol and loading dust;
- test air flow rate.

### 11.2 Interpretation of test reports

The following brief digest shall be included in the test reports and summary reports, following the issued report and comprising a one-page addition of the text sized to fill the page.

#### ***Interpretation of test reports***

*This brief review of the test procedures, including those for addressing the testing of electrostatically charged filters, is provided for those unfamiliar with ISO/TS 21220 procedures. It is intended to assist in the understanding and interpretation of the results in the test report/summary (for further details, consult ISO/TS 21220).*

*Many types of air filter rely on the effects of passive static electrical charges on the fibres to achieve high efficiencies, particularly in the initial stages of their working life. Environmental factors encountered in service can affect the action of these electric charges so that the initial efficiency could drop substantially after an initial period of service. In many cases this is offset or countered by an increase in efficiency ("mechanical efficiency") as dust deposits build up to form a dust cake. In the later stages of operating life the efficiency can increase to equal or exceed the initial efficiency. The reported, untreated and conditioned (discharged) efficiency shows the extent of the electrical charge effect on initial performance and indicates the level of efficiency reachable when the charge effect is completely removed and there is not a compensating increase of the mechanical efficiency.*

*The reported untreated and conditioned (discharged) efficiencies show the extent of the electrical charge effect on initial performance. It should not be assumed that the measured conditioned (discharged) efficiency represents real life behaviour. It merely indicates the level of efficiency obtainable with the charge effect completely removed and with no compensating increase in mechanical efficiency.*



*For reasons of consistency, filter efficiencies are measured using artificially generated dust clouds of synthetic dusts with closely controlled particle size. The test dust selected for testing a given filter depends on its initial filtration efficiency with respect to 0,4 µm liquid droplets.*

*If this is below (or known to be below) 20 %, the filter will be tested using the “coarse” procedure, in which the efficiency is determined by challenging it with an aerosol of neutralized KCl particles. The efficiency is determined within the particle size range 1,0 µm to 5,5 µm.*

*If the efficiency of medium samples after treatment to remove the electrostatic charges is equal to or exceeds (or is known to exceed) 20 %, the complete filter will be tested using the “fine” procedure, in which the challenge is a liquid aerosol of DEHS droplets. Efficiency measurements are made within the particle size range 0,3 µm to 1,2 µm.*

*Samples of media from filters tested using the coarse method are also treated (conditioned) and their efficiencies before and after treatment determined using the coarser test aerosol (1,0 µm to 5,5 µm).*

*The efficiency measurements are repeated after the filter has been loaded with ASHRAE loading dust until the resistance has risen to a value of 250 Pa (1,0 in WG) in the case of the “coarse” procedure and after it has been loaded with ISO 12103-A dust up to a value of 375 Pa (1,5 in WG) for the fine procedure.*

*Test dust capacities measured in this way should not be assumed to simulate real life operating conditions as the properties of dusts encountered in service conditions vary very widely. Comparative performances and rankings may be established, but it should always be borne in mind that the actual conditions on site will determine the in-service filter performance.*

### 11.3 Summary

As applicable, the one-page summary section of the performance report (Figure 12) shall include the following:

— General:

- 1) testing organization;
- 2) date of test;
- 3) name of test operator;
- 4) report number;
- 5) test requested by;
- 6) name of supplier of device;
- 7) date of receiving the device.

— Manufacturer’s data of the tested device:

- 8) description of the device;
- 9) type, identification and marking;
- 10) name of manufacturer;
- 11) physical description of construction (e.g. pocket filter, number of pockets);
- 12) dimensions (actual width, height and depth);

- 13) type of media with, if possible or available, the
  - i) identification code (e.g. glass fibre type ABC123, inorganic fibre type 123ABC),
  - ii) effective device area,
  - iii) total media area in device, and
  - iv) type and amount of dust adhesive on filter media if feasible;
- 14) photographs of the air entering and air leaving sides of the as-received device;
- 15) additional information as needed for proper filter identification.

— Test data:

- 16) test air flow rate;
- 17) test air temperature, relative humidity and barometric pressure;
- 18) type of loading dust and test aerosol;
- 19) initial pressure drop and final test pressure drop;
- 20) pressure drop curve versus air flow rate for clean filter;
- 21) table of initial efficiency, conditioned efficiency and dust loaded efficiency versus particle size:
  - i) fine method sizes: 0,4 µm, 0,5 µm, 0,7 µm and 1,0 µm
  - ii) coarse method sizes: 1,5 µm, 2,5 µm, 3,0 µm and 5,0 µm

EXAMPLE Efficiency versus DEHS particles

| Efficiency  | Optical particle size, µm |     |     |     |
|-------------|---------------------------|-----|-----|-----|
|             | 0,4                       | 0,5 | 0,7 | 1,0 |
| Filter:     |                           |     |     |     |
| Initial     | ±                         | ±   | ±   | ±   |
| Dust loaded | ±                         | ±   | ±   | ±   |
| Media:      |                           |     |     |     |
| Initial     | ±                         | ±   | ±   | ±   |
| Conditioned | ±                         | ±   | ±   | ±   |

- 22) test dust capacity;
- 23) arrestance.

— Statement:

- 24) the results relate only to the tested item;
- 25) the performance results cannot by themselves be quantitatively applied to predict filter performance in service.

In the summary report, the results shall be rounded to the nearest integer.

## 11.4 Efficiency

In addition to the summary report, when applicable, the results of the efficiency measurements shall be reported in tables and as graphs.

— Tables:

- 1) efficiency and uncertainty at each particle size after dust loading to final test pressure drop (see Table 8);
- 2) pressure drop versus air flow for clean filter (see Table 9);
- 3) pressure drop and arrestance (see Table 10);
- 4) efficiency and pressure drop in the conditioning test according to Annex A (see Tables 11 and 12).

— Graphs: initial and dust-loaded efficiency (final test pressure drop) versus particle size (see Figure 13).

## 11.5 Pressure drop and air flow rate

When applicable, all required data and results of the air flow rate and pressure drop measurements throughout the complete test shall be reported in tabular format. The pressure drop curve for the clean filter is reported in the summary section.

The air flow shall be reported as measured while the pressure drops shall be corrected to an air density of 1,20 kg/m<sup>3</sup> (0,075 lb/ft<sup>3</sup>), if required in accordance with 9.3 and Annex D.

## 11.6 Marking

The filter shall be marked with a type identifying marking. The following details shall be provided:

- name, trade mark or other means of identification of the manufacturer;
- type and reference number of the filter;
- number of this Technical Specification;
- Class/rating of the filter per National or Association bodies for classification or rating of air filter devices;

NOTE Classification or rating is not part of this Technical Specification.

- flow rate at which the filter has been tested.

If the correct mounting cannot be deduced, marking is necessary for correct fitting in the ventilation duct (e.g. “top”, “direction of flow”).

The marking shall be as clearly visible and as durable as possible.

| ISO/TS 21220:2009 — Air filter test results   |                            |                             |                                   | Fine                                  | <del>Coarse</del> |
|---|----------------------------|-----------------------------|-----------------------------------|---------------------------------------|-------------------|
| Testing organization:   |                            |                             | Report no.:                       |                                       |                   |
| <b>General</b>  |                            |                             |                                   |                                       |                   |
| Test no.:   |                            | Date of test: yyyy-mm-dd    |                                   | Supervisor:                           |                   |
| Test requested by:  |                            |                             | Device reception date: yyyy-mm-dd |                                       |                   |
| Device supplied by:   |                            |                             |                                   |                                       |                   |
| <b>Device tested</b>  |                            |                             |                                   |                                       |                   |
| Model:  |                            | Manufacturer:               |                                   | Construction:                         |                   |
| Type of media:  |                            | Effective filtering area:   |                                   | Actual filter dimensions (W × H × D): |                   |
| <b>Test data</b>  |                            |                             |                                   |                                       |                   |
| Test air flow rate:   | Test air temp.:            | Test air relative humidity: | Test aerosol:                     |                                       |                   |
|   |                            | %                           | Loading dust:                     |                                       |                   |
| <b>Results</b>  |                            |                             |                                   |                                       |                   |
| Initial pressure drop:  | Final test pressure drop:  | Arrestance:                 | TDC:                              | Remark:                               |                   |
| <b>Efficiency versus DEHS particles</b>   |                            |                             |                                   |                                       |                   |
| Efficiency  | Particle size <sup>a</sup> |                             |                                   |                                       |                   |
|   | µm                         |                             |                                   |                                       |                   |
|   | 0,4                        | 0,5                         | 0,7                               | 1,0                                   |                   |
| Filter  |                            |                             |                                   |                                       |                   |
| Initial   | ±                          | ±                           | ±                                 | ±                                     |                   |
| Dust loaded   | ±                          | ±                           | ±                                 | ±                                     |                   |
| Media   |                            |                             |                                   |                                       |                   |
| Initial   | ±                          | ±                           | ±                                 | ±                                     |                   |
| Conditioned   | ±                          | ±                           | ±                                 | ±                                     |                   |
| <sup>a</sup> See the attached interpretation of the test report.  |                            |                             |                                   |                                       |                   |
| <b>Pressure versus air flow</b>   |                            |                             |                                   |                                       |                   |
| <div style="margin-left: 400px;"> <p><b>Key</b></p> <p>X air flow</p> <p>Y pressure drop</p> </div>   |                            |                             |                                   |                                       |                   |
| The performance results are only valid for the tested item and cannot by themselves be quantitatively applied to predict filter performance in service. |                            |                             |                                   |                                       |                   |

Figure 12 — Summary section of performance report

**Table 8 — Initial efficiency and loaded efficiency inclusive of uncertainty**

| ISO/TS 21220:2009 — Initial and loaded efficiency including uncertainty |      |                            |                        |           |         |
|---|------|----------------------------|------------------------|-----------|---------|
| Air filter:   |      |                            |                        |           |         |
| Test no.:   |      |                            |                        |           |         |
| Test aerosol:   |      |                            |                        |           |         |
| Air flow rate:  |      |                            |                        |           |         |
| Particle size<br>µm   |      | Efficiency<br>%            |                        |           | Remarks |
|   |      | Pressure drop and dust fed |                        |           |         |
| Interval  | Mean | Initial pressure           | Final                  |           |         |
|   |      | Pa (in WG)<br>for 0 g      | Pressure<br>Pa (in WG) | Dust<br>g |         |
| —   |      | ±                          | ±                      | ±         |         |
| —   |      | ±                          | ±                      | ±         |         |
| —   |      | ±                          | ±                      | ±         |         |
| —   |      | ±                          | ±                      | ±         |         |
| —   |      | ±                          | ±                      | ±         |         |
| —   |      | ±                          | ±                      | ±         |         |
| —   |      | ±                          | ±                      | ±         |         |
| —   |      | ±                          | ±                      | ±         |         |
| —   |      | ±                          | ±                      | ±         |         |
| —   |      | ±                          | ±                      | ±         |         |

The uncertainty of the measured efficiencies is reported on a 95 % confidence level.  
 Report any correction of efficiency based on release of particles from the filter.

**Air filter:**

Initial and dust-loaded efficiency at final pressure drop

ISO/TS 21220:2009

Test no.: .....

Test aerosol:..... Loading dust:.....

Air flow rate: ..... Final test pressure drop: .....

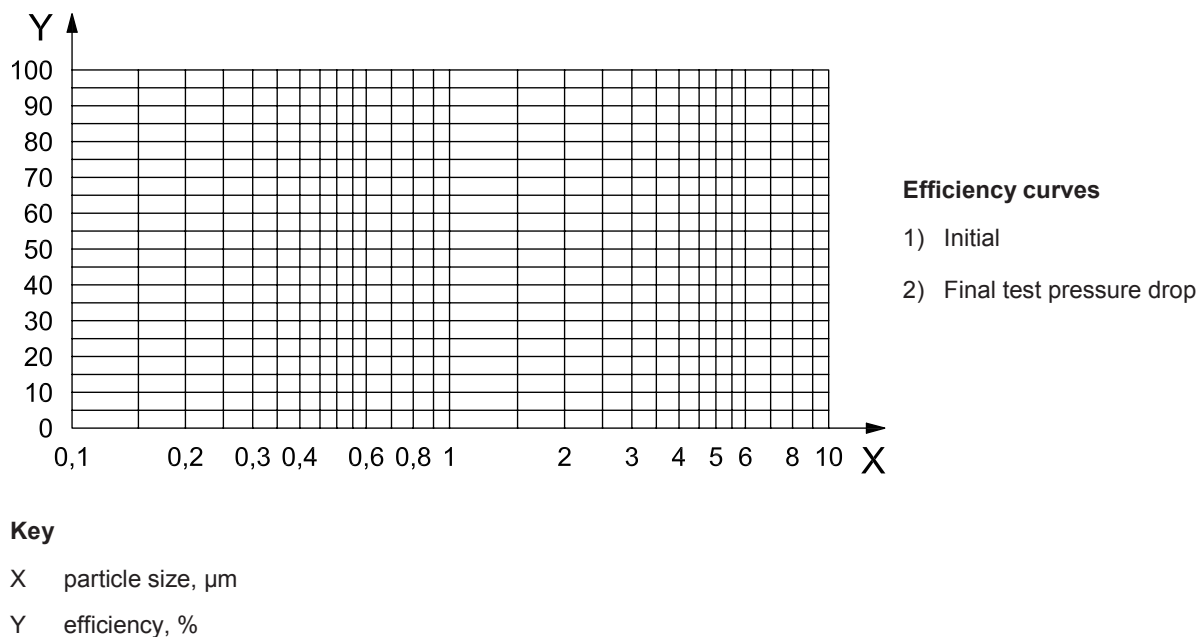

**Figure 13 — Initial and dust-loaded efficiencies**

Table 9 — Air flow rate and pressure drop of clean filter

| ISO/TS 21220:2009 — Air flow rate and pressure drop of clean filter |   |  |   |   |                   |   |                         |  |  |                             |                                    |
|---|---|--|---|---|-------------------|---|-------------------------|--|--|-----------------------------|------------------------------------|
| Air filter:   |   |  |   |   |                   |   |                         |  |  |                             |                                    |
| Test no.:   |   |  |   |   |                   |   |                         |  |  |                             |                                    |
| Air flow rate:  |   |  |   |   |                   |   |                         |  |  |                             |                                    |
| Date  | Air flow meter  |  |   |   | Filter            |   |                         |  |  |                             |                                    |
|   | $T_f$<br>°C<br>(°F)   | $p_{sf}$<br>kPa<br>(lb/in <sup>2</sup> ) | $\Delta p_f$<br>Pa<br>(lb/in <sup>2</sup> ) | $q_m$<br>kg/m <sup>3</sup><br>(lb/ft <sup>3</sup> ) | $T$<br>°C (°F)    | $\varphi$<br>%  | $p_a$<br>kPa<br>(in WG) | $\rho$<br>kg/m <sup>3</sup><br>(lb/ft <sup>3</sup> ) | $q_V$<br>m <sup>3</sup> /s<br>(ft <sup>3</sup> /min) | $\Delta p$<br>Pa<br>(in WG) | $\Delta p_{1,20}$<br>Pa<br>(in WG) |
| yyyy-mm-dd  | Clean filter  |  |   |   |                   |   |                         |  |  |                             |                                    |
|   |   |  |   |   |                   |   |                         |  |  |                             |                                    |
|   |   |  |   |   |                   |   |                         |  |  |                             |                                    |
|   |   |  |   |   |                   |   |                         |  |  |                             |                                    |
|   |   |  |   |   |                   |   |                         |  |  |                             |                                    |
|   |   |  |   |   |                   |   |                         |  |  |                             |                                    |
|   |   |  |   |   |                   |   |                         |  |  |                             |                                    |
|   | Clean filter pressure drop is proportional to $(q_V)^n$ , where $n =$   |  |   |   |                   |   |                         |  |  |                             |                                    |
| $p_a$   | absolute air pressure upstream of filter, kPa (in WG)                   |  |   |   | $q_V$             | air flow rate at filter, m <sup>3</sup> /s (ft <sup>3</sup> /min)   |                         |  |  |                             |                                    |
| $\rho$  | air density upstream of filter, kg/m <sup>3</sup> (lb/ft <sup>3</sup> ) |  |   |   | $\Delta p_f$      | air flow meter differential pressure, Pa (lb/in <sup>2</sup> )  |                         |  |  |                             |                                    |
| $p_{sf}$  | air flow meter static pressure, kPa (lb/in <sup>2</sup> )               |  |   |   | $T$               | temperature upstream of filter, °C (°F)   |                         |  |  |                             |                                    |
| $\varphi$   | relative humidity upstream of filter, %                                 |  |   |   | $\Delta p_{1,20}$ | filter pressure drop at nominal air density of 1,20 kg/m <sup>3</sup> (0,075 lb/ft <sup>3</sup> ), Pa (in WG) |                         |  |  |                             |                                    |
| $q_m$   | mass flow rate, kg/m <sup>3</sup> (lb/ft <sup>3</sup> )                 |  |   |   | $T_f$             | temperature at air flow meter, °C (°F)  |                         |  |  |                             |                                    |
| $\Delta p$  | measured filter pressure drop, Pa (in WG)                               |  |   |   |                   |   |                         |  |  |                             |                                    |

**Table 10 — Pressure drop and arrestance after loading to final test pressure drop**

| ISO/TS 21220:2009 — Pressure drop and arrestance after loading to final test pressure drop  |                            |                 |                |                            |            |            |                      |            |          |
|---|----------------------------|-----------------|----------------|----------------------------|------------|------------|----------------------|------------|----------|
| Air filter:   |                            |                 |                |                            |            |            |                      |            |          |
| Test no.:   |                            |                 |                |                            |            |            |                      |            |          |
| Type of loading dust:   |                            |                 |                |                            |            |            |                      |            |          |
| Air flow rate:  |                            |                 |                |                            |            |            |                      |            |          |
| Date  | $\Delta p_1$<br>Pa (in WG) | $\Delta m$<br>g | $m_{tot}$<br>g | $\Delta p_2$<br>Pa (in WG) | $m_1$<br>g | $m_2$<br>g | $\Delta m_{ff}$<br>g | $m_d$<br>g | $A$<br>% |
| yyyy-mm-dd  |                            |                 |                |                            |            |            |                      |            |          |
| yyyy-mm-dd  |                            |                 |                |                            |            |            |                      |            |          |
| yyyy-mm-dd  |                            |                 |                |                            |            |            |                      |            |          |
| yyyy-mm-dd  |                            |                 |                |                            |            |            |                      |            |          |
| yyyy-mm-dd  |                            |                 |                |                            |            |            |                      |            |          |
| yyyy-mm-dd  |                            |                 |                |                            |            |            |                      |            |          |
| <b>Mass of tested device</b>  |                            |                 |                |                            |            |            |                      |            |          |
| Initial mass of tested device:  |                            |                 | g              |                            |            |            |                      |            |          |
| Final mass of tested device:  |                            |                 | g              |                            |            |            |                      |            |          |
| <p><math>A</math> arrestance, %</p> <p><math>m_d</math> dust in duct after device, g</p> <p><math>m_{tot}</math> cumulative mass of dust fed to filter, g</p> <p><math>m_1</math> mass of final filter before dust increment, g</p> <p><math>m_2</math> mass of final filter after dust increment, g</p> <p><math>\Delta m</math> dust increment, g</p> <p><math>\Delta m_{ff}</math> mass gain of final filter, g</p> <p><math>\Delta p_1</math> pressure drop before dust increment, Pa (in WG)</p> <p><math>\Delta p_2</math> pressure drop after dust increment, Pa (in WG)</p> |                            |                 |                |                            |            |            |                      |            |          |



**Table 11 — Efficiency and pressure drop of untreated filter material**

| ISO/TS 21220:2009 — Efficiency and pressure drop of untreated filter material       |             |                      |          |                 |          |          |         |
|---|-------------|----------------------|----------|-----------------|----------|----------|---------|
| Air filter:   |             |                      |          |                 |          |          |         |
| Test no.:   |             |                      |          | Test aerosol:   |          |          |         |
| Air flow rate:  |             |                      |          | Media velocity: |          |          |         |
| Size of material sample:  |             |                      |          |                 |          |          |         |
| Particle size, $\mu\text{m}$  |             | Sample 1             | Sample 2 | Sample 3        | Sample 4 | Sample 5 | Average |
|   |             | <b>Efficiency, %</b> |          |                 |          |          |         |
|   |             | <b>Pressure drop</b> |          |                 |          |          |         |
| <b>Interval</b>   | <b>Mean</b> | Pa (in WG)           |          |                 |          |          |         |
| —   |             | ±                    | ±        | ±               | ±        | ±        |         |
| —   |             | ±                    | ±        | ±               | ±        | ±        |         |
| —   |             | ±                    | ±        | ±               | ±        | ±        |         |
| —   |             | ±                    | ±        | ±               | ±        | ±        |         |
| —   |             | ±                    | ±        | ±               | ±        | ±        |         |
| The uncertainty of the measured efficiencies is reported on a 95 % confidence level |             |                      |          |                 |          |          |         |

**Table 12 — Efficiency and pressure drop of conditioned filter material**

| ISO/TS 21220:2009 — Efficiency and pressure drop of treated filter material         |             |                      |            |                 |            |            |            |
|---|-------------|----------------------|------------|-----------------|------------|------------|------------|
| Air filter:   |             |                      |            |                 |            |            |            |
| Test no.:   |             |                      |            | Test aerosol:   |            |            |            |
| Air flow rate:  |             |                      |            | Media velocity: |            |            |            |
| Size of material sample:  |             |                      |            |                 |            |            |            |
| Particle size, $\mu\text{m}$  |             | Sample 1             | Sample 2   | Sample 3        | Sample 4   | Sample 5   | Average    |
|   |             | <b>Efficiency, %</b> |            |                 |            |            |            |
|   |             | <b>Pressure drop</b> |            |                 |            |            |            |
| <b>Interval</b>   | <b>Mean</b> | Pa (in WG)           | Pa (in WG) | Pa (in WG)      | Pa (in WG) | Pa (in WG) | Pa (in WG) |
| —   |             | ±                    | ±          | ±               | ±          | ±          |            |
| —   |             | ±                    | ±          | ±               | ±          | ±          |            |
| —   |             | ±                    | ±          | ±               | ±          | ±          |            |
| —   |             | ±                    | ±          | ±               | ±          | ±          |            |
| —   |             | ±                    | ±          | ±               | ±          | ±          |            |
| The uncertainty of the measured efficiencies is reported on a 95 % confidence level |             |                      |            |                 |            |            |            |

## Annex A (normative)

### Conditioning test

#### A.1 General

Certain types of filter media rely on electrostatic effects to achieve high efficiencies at low resistance to air flow. Exposure to some types of challenge, such as combustion particles, fine particles or oil mist, can neutralize such charges and cause filter performance to suffer. It is important for users of filters to be aware of the possibility of performance degradation during operational life.

The filter conditioning test as set out in this annex shall be used to determine whether the filter efficiency is dependent on the electrostatic removal mechanism and to provide quantitative information about the importance of the electrostatic removal. This is accomplished by measuring the removal efficiency of an untreated filter material and the corresponding efficiency after the effect of the electrostatic removal mechanism has been eliminated or inhibited.

#### A.2 Test method

##### A.2.1 Equipment

The test method is based on standardized treatment with isopropanol (IPA) to evaluate electrostatic influence on filter efficiency. First, the efficiency of untreated media samples is measured. Next, the samples are immersed in isopropanol (> 99,5 % technical grade). If IPA is reused, the IPA purity must remain above 99,5 %. After filter samples have been wetted by the isopropanol, they are placed on a flat, inert surface in a fume cupboard for drying for 24 h, following which the efficiency measurements are repeated. To verify that the sample is free from residual IPA, it is purged for 1 h with clean dry air and the efficiency test is repeated.

The principle of the filter material test equipment is shown in Figure A.1. This system consists of a test duct, a flow meter, a flow control valve, a (downstream) sampling tube and a manometer. The filter sample to be tested is fixed to the test tube by means of a flange. The test tube also includes a mixing section, which ensures representative sampling downstream of the filter. The sampling tubes are connected to the sampling system of the particle size analyser. Air and test aerosol could be taken from the main duct system, which means that the normal aerosol generation system can be used.

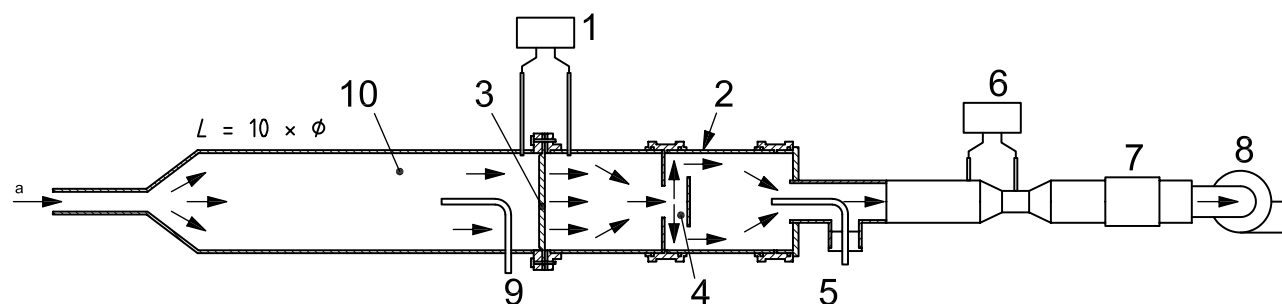

**Key**

- |   |                |   |                     |     |                   |
|---|----------------|---|---------------------|-----|-------------------|
| 1 | manometer      | 5 | downstream sampling | 9   | upstream sampling |
| 2 | test duct      | 6 | flow meter          | 10  | upstream duct     |
| 3 | filter sample  | 7 | flow control        | $L$ | length            |
| 4 | mixing section | 8 | fan                 | $a$ | Aerosol.          |

**Figure A.1 — Filter material test equipment**

The isopropanol treatment is performed using the system shown in Figure A.2. This system includes a vessel for the isopropanol, as well as flat perforated surfaces on which filter samples are placed for drying. The drying of the filter samples should take place in a laboratory fume cupboard.

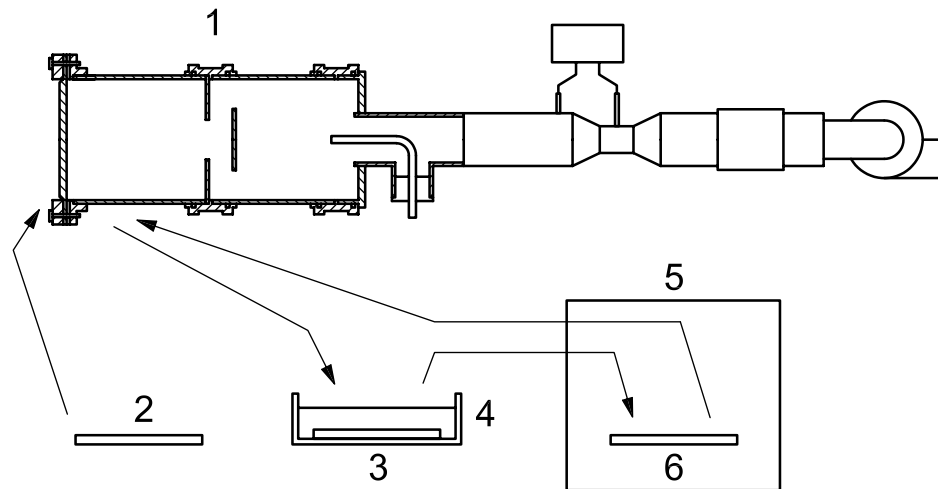

**Key**

- 1 efficiency measurement
- 2 filter sample
- 3 treatment
- 4 isopropanol vessel
- 5 fume cupboard
- 6 drying

**Figure A.2 — Principle of isopropanol test system**

**A.2.2 Preparation of test samples**

A minimum of three media samples shall be tested. Representative samples shall be supplied by the customer or selected from a second filter identical to the filter used in the main test. Samples from the filter shall be selected (e.g. by cutting) such that they represent the complete filter. The locations at which media samples are to be cut shall be randomized. If flat samples cannot be cut from the filter, a small piece from the filter shall be cut out and sealed into a frame fitting into the test system.

The effective media sample area should be  $\geq 200 \text{ cm}^2$  (0,21 5 ft<sup>2</sup>), but the media area samples may be extended to obtain more representative samples of the filter; nevertheless, effective media size shall be a maximum of 0,61 m  $\times$  0,61 m (24 in  $\times$  24 in).

**A.2.3 Measurement of filter medium efficiency**

Start the test by mounting a filter sample in the test equipment. Adjust the velocity through the filter sample so that it is the same as the nominal media velocity used in the filter (using effective filtering area). Measure the filter sample pressure drop.

Determine the particulate filtration efficiency of the sample by measuring the particle concentrations from upstream and downstream of the filter sample. The criteria for test aerosol, size range and efficiency measurement are in accordance with the main body of this Technical Specification.

#### A.2.4 Test procedure

Perform the test as follows.

- a) Measure the initial efficiency and pressure drop values of the filter samples.
- b) Immerse the filter samples for 2 min.
- c) Place the filter samples on a flat, inert surface for drying. This should take place in a laboratory fume cupboard. To allow quick evaporation of the IPA, the samples should be placed on a perforated surface surrounded by air.
- d) After drying for 24 h, repeat the efficiency and pressure drop measurements.
- e) After purging for 1 h with dry, clean air, repeat the test for one of the samples. If the efficiency has changed more than  $\pm 3$  percentage points and/or the pressure drop has changed by more than  $\pm 5$  Pa ( $\pm 0,2$  in WG), purge all the samples for an additional 1 h with clean air and retest.
- f) Calculate the average efficiencies of the untreated and conditioned filter samples. Then compare the average initial efficiency of the samples with the initial efficiency of the filter. If the average efficiency of these samples differs by more than  $\pm 5$  percentage points from the initial efficiency of the filter, then two more samples shall be tested and included in an overall average calculation.

#### A.3 Calculation and expression of results

The average efficiencies of the untreated and conditioned filter samples shall be reported together with the aerosol and size range (DEHS,  $0,3 \mu\text{m}$  to  $1,2 \mu\text{m}$  for the fine method and KCl,  $1 \mu\text{m}$  to  $5,5 \mu\text{m}$  for the coarse method).

## Annex B (informative)

### Shedding from filters

#### B.1 General

*Shedding* comprises three separate aspects of filter behaviour: the re-entrainment of particles, particle bounce and the release of fibres or particulate matter from filter material. One or more or all three of these phenomena are likely to occur to some extent during the life cycle of an installed filter, especially in dry weather conditions.

NOTE For shedding and its effect on filter performances in the literature, see References [14], [16], [17], [18], [19] and [20].

#### B.2 Re-entrainment of particles

As the quantity of the arrested dust on the filter increases, the following effects can lead to re-entrainment of already captured particles into the air stream:

- a) an incoming particle could impact on a captured particle and re-entrain it into the air stream;
- b) the air velocity in the channels through the medium can increase because of the space occupied by captured particles, the filter medium could also become compressed by the increased resistance to airflow, thereby causing even further increase in velocity in the air channels, and the consequent increased fluid drag on deposited particles could re-entrain some of them;
- c) movements of the filter medium during operation can cause re-arrangement of dust in the filter medium structure, leading to an immediate re-entrainment of dust, with such filter media movements being caused by a variety of circumstances, including
  - 1) normal air flow through the filter,
  - 2) periodic (e.g. daily) start/stop operation of the air conditioning plant,
  - 3) varying air flow rates, caused by air flow control, or
  - 4) mechanical vibration, caused by the fan or other equipment.

Re-entrainment of particles can be measured and quantified; see References [4], [10].

This effect is more pronounced for low-efficiency filters than for high-efficiency filters.

#### B.3 Particle bounce

##### B.3.1 General

In an ideal filtration process, each particle would be permanently arrested at the first collision with a filtering surface such as a fibre, or with an already captured particle. For small particles and low air velocities, the energy of adhesion greatly exceeds the kinetic energy of the airborne particle in the air stream and, once captured, such particles are very unlikely to be dislodged from the filter. As particle size and air velocity increase, this is progressively less so; larger particles can “bounce” off a fibre. Thereby, they normally lose enough energy to allow capture in a subsequent collision with a fibre. However, if no contact with a fibre follows, the particle will be shed, i.e. discharged from the filter, which will result in a corresponding reduction of efficiency for particles of this size range [2], [3].

A measurement method for quantifying this type of shedding is defined in ANSI/ASHRAE 52.2 [1], using solid KCl particles of relatively large size ( $> 3 \mu\text{m}$ ). Using liquid aerosol, the particle bounce effect cannot be measured at all.

The particle bounce effect is more pronounced for low-efficiency filters than for high-efficiency filters.

### **B.3.2 Release of fibres or particulate matter from filter material**

Some designs of filter include filter media containing and/or generating loose fibres or particulate matter from the filter's design materials (e.g. binder). During constant volume filter operation, but especially during variable flow or start-stop operation, these materials can be lost into the air stream. The extent of such shedding depends on the integrity of the media fibre structure and its rigidity and stability in the face of varying air velocities, as well as the stability of the filter design materials (e.g. the binder holding fibres together), throughout the operating life of the filter. It should be noted, however, that the quantity of fibres or particulate matter shed in this way is normally negligible in comparison with the total amount of dust penetrating through a filter loaded by typical environmental dust burden [5], [6].

## **B.4 Testing of shedding effects**

Users should be aware of the possibility of filters exhibiting shedding behaviour in practical use. From the user's point of view it would be advantageous to detect any shedding behaviour of a filter. However, such measurements are not easily performed.

The arrestance measurements for low-efficiency filters prescribed in this Technical Specification reflect the above-described shedding effects only partly, if at all. However, any drop in the value of the arrestance or resistance during the course of a filter loading test should be taken as a serious indication that shedding could have occurred.

The efficiency/particle size results for higher-efficiency filters provided in this Technical Specification normally reflect none of the above-described shedding effects, as the aerosol used for these filters is a liquid (DEHS) aerosol.

Membrane sampling downstream of filters and microscopic analyses of the membranes could determine occurrence of this type of shedding, but such a method is not defined here.

## Annex C (informative)

### Commentary

#### C.1 General

The procedures described in this Technical Specification have been developed from those of EN 779 [5] and ANSI/ASHRAE 52.2 [1]. On the one hand, the basic design of the test rig from EN 779 has been retained. On the other hand, classification of filters by efficiencies has been excluded and it is left at the discretion of national or association bodies to develop their own ratings.

This annex gives an overview of the test methods and procedures.

#### C.2 Principle

##### C.2.1 Basic

The test is designed for an airflow from 0,25 m<sup>3</sup>/s to 1,5 m<sup>3</sup>/s (900 m<sup>3</sup>/h to 5400 m<sup>3</sup>/h). Filter classification is not included in this Technical Specification but, for use by other standards, the nominal air test flow rate is to be 0,944 m<sup>3</sup>/s (2000 ft<sup>3</sup>/min or 3400 m<sup>3</sup>/h) if not otherwise specified by the manufacturer for applications other than HVAC.

Two test methods are combined in this Technical Specification. The “fine” method for air filters in the higher efficiency range and the “coarse” method for lower-efficiency filters. In both cases, samples from the filter are conditioned (discharged) to provide information about the intensity of the electrostatic removal mechanism. Two filters of the same quality are needed: one for the main filter test and the other for media samples (or partial/complete filter) for the electrostatic condition (discharge) test.

After the determination of the initial efficiency, the filters are loaded with synthetic dust in one step up to final test pressure drop. This can give information of the shedding behaviour of the filter as well as test dust capacity and filtration efficiency with respect to the loading dust (arrestance). The two methods use different particle size ranges, test aerosols, loading dusts and final test pressure drops. See Table 5.

The criteria for selecting the method to be used in any particular case are based on initial and conditioned efficiencies. Filters with initial efficiency and conditioned efficiency greater than or equal to 20 % on 0,4 µm DEHS particles are tested using the fine method while other filters are tested using the coarse method.

##### C.2.2 Size range

Two size ranges are used: 0,3 µm to 1,2 µm for filters in the higher efficiency range (fine method) and 1 µm to 5,5 µm for filters with lower efficiency (coarse method).

Filters tested according to the fine method have high efficiency above 1 µm and there is not much added value for testing against larger particles; filters with lower efficiency can show quite different performance for larger particles, making it useful to test with such particles.

##### C.2.3 Test aerosol

Two different test aerosols are used: liquid DEHS particles in the fine method and solid KCl particles in the coarse method.

The efficiency of DEHS and KCl cannot be directly compared, owing to differences in density, light scattering, charging and the behaviour of the different test aerosols in the filter media, such as particle bounce.

The KCl aerosol is brought to a Boltzmann electrostatic charge distribution (an equal amount of plus and minus charges in the aerosol). The charged aerosol particles will influence the efficiency of electrostatically charged filter material.

The aerodynamic, geometric and light scattering KCl sizes differ from each other when measured with optical particle counters. The density of KCl is about  $2 \text{ g/cm}^3$ , which means that the geometric size =  $2^{1/2} = 1,4$  times aerodynamic size. The solid KCl aerosol does not wet the filter fibres and reflects shedding performance or reduction in efficiency better than liquid particles, which can be of importance in the lower-efficiency filter range.

Higher-efficiency filters are not noticeably influenced by the type of test aerosol (liquid/solid). The DEHS aerosol is used untreated without any charge on the particles. The aerodynamic, geometric and light scattering sizes are close to each other when measured with optical particle counters. The DEHS (or equivalent) was chosen for the fine test method for the following reasons:

- easy to generate in size range with simple equipment (Laskin nozzle);
- the response time of the DEHS generator is fast and testing can start almost immediately;
- clean to use, no corrosion problem;
- commonly used in testing of high-efficiency filters and *in situ* tests;
- does not need radioactive source (not allowed in some countries) or corona discharge ionizer;
- same geometric and aerodynamic particle size;
- efficiency results close to solid particles in size range  $0,3 \mu\text{m}$  to  $1,2 \mu\text{m}$ ;
- the maintenance cost and work is low with DEHS — no need to rinse the generator, no need to calibrate any neutralizer, etc.;
- DEHS does not affect the pressure drop of the filter.

#### C.2.4 Loading dust

Two types of loading dust are used: ISO 12103-A dust for the fine method and ASHRAE dust for the coarse method. The filters are loaded to final test pressure drop in one step. The loaded efficiency is then measured to indicate any change in performance.

These loading dusts are not representative of the real world, but are used to *simulate* dust loading. The loading could give information of the filter's mechanical and aerodynamic design but there is no general correlation between synthetic dust capacity and real-life capacity and the dust loading capacity is not presented in the summary report. The dust loading tests can, to some extent, indicate shedding problems.

ISO 12103-A (fine) dust is clean and easy to use, its specification is better defined than for the ASHRAE dust and it will indicate shedding performance better. The test dust capacity will increase two to five times with ISO 12103-A dust. To reduce the required test time, the loading concentration has been increased from  $70 \text{ mg/m}^3$  ( $2,0 \text{ g/1 000 ft}^3$ ) to  $140 \text{ mg/m}^3$  ( $4,0 \text{ g/1 000 ft}^3$ ).



The ASHRAE dust is kept for the lower-efficiency filters because of the better experience with using this dust with these filters. These low-efficiency filters can service as the first filter in an ambient air intake filter system or can be used in exhaust systems to protect duct and equipment from coarse dust and fibres. The filters can experience higher concentrations of ambient hydrocarbon compounds and fibres. The carbon content and the lint of the ASHRAE dust affects the efficiency and dust holding of these filters and more closely simulates actual field service performance than the ISO 12103-A test dust. The concentration has been kept to 70 mg/m<sup>3</sup> (2,0 g/1 000 ft<sup>3</sup>) as in the older standards.

### C.2.5 Conditioning test

Certain types of filter media rely on electrostatic effects to achieve high efficiencies at low resistance to air flow. Exposure to some types of challenge, such as combustion particles, fine particles or oil mist can neutralize such charges, with the result that filter efficiency can decrease over time. The exact efficiency is dependant on the media type, the actual particle content of the ambient intake air as well as other environmental factors. It is important for users of filters to be aware of the possibility of performance degradation during operational life.

Conditioning according to the IPA method specified in Annex A was chosen for the following reasons:

- the test indicates the minimum efficiency of the filters that could happen in real applications;
- round robin tests, research work and tests have confirmed the uniformity of the method and its relevance;
- there is no, or a moderate, increase in pressure drop of the media or filters;
- many years of experience with the method;
- existing standardized methods.

The procedure was selected because it is well established, reproducible, simple to perform, relatively quick and because an acceptable alternative procedure is not available. Selection of this approach in this Technical Specification is not intended to slow or preclude the development of aerosol-based conditioning procedures by other organizations; an aerosol-based procedure might better reflect filtration changes that occur in actual use.

## C.3 Interpretation of test results

The interpretation of test results given in 11.2 is included in the test report.

### C.4 Flat-sheet test

The minimum air flow in this Technical Specification is 0,25 m<sup>3</sup>/s (530 ft<sup>3</sup>/min), which means that flat-sheet material cannot be tested directly as a flat sheet using a speed lower than 0,65 m/s (128 ft/min). For testing at lower velocities through the material, mounting has to be with an extended surface. If the material is fixed to a W-shaped frame system, it can be tested as a common filter. There is no correlation between the W-shape and flat sheet, but the method could be used for comparing and evaluating material.

Figure C.1 describes a typical W-form construction which could be used for evaluating filter material. The W-form gives a 1 m<sup>2</sup> (11 ft<sup>2</sup>) effective filtering area and, therefore, the same figures representing the flow rate (in cubic metres per second) and the media velocity (in metres per second); 0,4 m<sup>3</sup>/s (848 ft<sup>3</sup>/min) gives 0,4 m/s (80 ft/min) through the media.

The filter material to be tested is laid on the frame and stretched and fastened to the frame with the help of the counter frames.

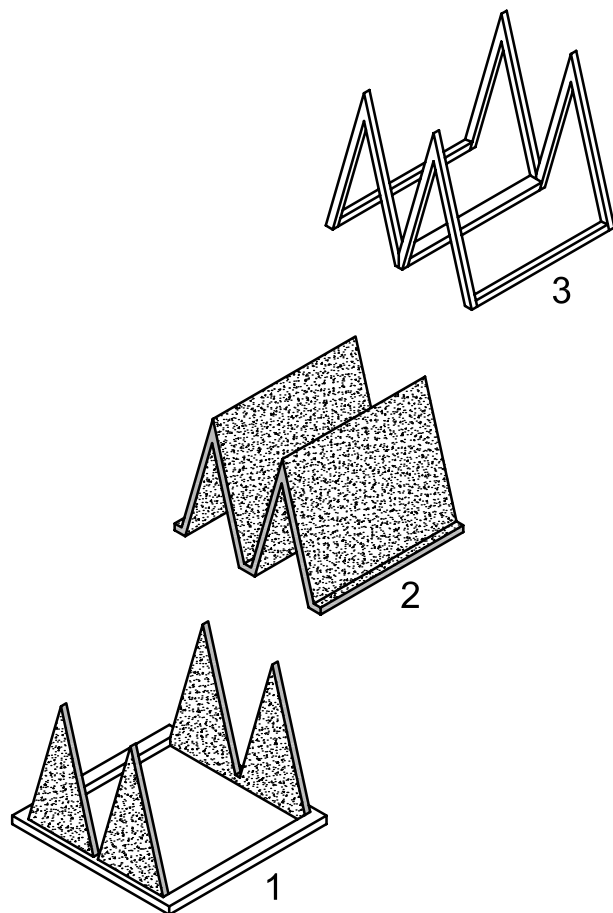

**Key**

- 1 W-form frame
- 2 filter material (1 m<sup>2</sup>)
- 3 W-form counter frame

**Figure C.1 — W-form frame and details for testing filter material — Example**

## Annex D (normative)

### Pressure drop calculation

All pressure losses measured during the test are to be corrected to a reference air density of 1,198 8 kg/m<sup>3</sup> (0,075 lbf/ft<sup>3</sup>), corresponding to standard air conditions: temperature 20 °C (68 °F), barometric pressure 101,325 kPa (14,6 lbf/in<sup>2</sup>), relative humidity 50 %. However, as long as the air density is between 1,16 kg/m<sup>3</sup> (0,072 4 lbf/ft<sup>3</sup>) and 1,24 kg/m<sup>3</sup> (0,077 4 lbf/ft<sup>3</sup>), no corrections need be made.

The pressure loss of a filter is expressed as:

$$\Delta p = c (q_V)^n \quad (\text{D.1})$$

$$c = k \times \mu^{2-n} \times \rho^{n-1} \quad (\text{D.2})$$

where

$\Delta p$  is the pressure loss, in Pa (in WG);

$c, k$  are constants;

$q_V$  is the air flow rate, m<sup>3</sup>/s (ft<sup>3</sup>/min);

$\mu$  is the dynamic viscosity of air, in Pa·s (lbf·s/ft<sup>2</sup>);

$n$  is an exponent;

$\rho$  is the air density, in kg/m<sup>3</sup>(lbf/ft<sup>3</sup>).

The readings of the air flow measuring system shall be converted to the volumetric air flow rate at the conditions prevailing at the inlet of the tested filter. With these air flow rate values and the measured pressure losses, exponent  $n$  from Equation (D.1) can be determined by using a least-squares technique.

With a known value of exponent  $n$ , the measured pressure losses can be corrected to standard air conditions using Equation (D.3):

$$\Delta p_{1,20} = \Delta p \left( \frac{\mu_{1,20}}{\mu} \right)^{2-n} \times \left( \frac{\rho_{1,20}}{\rho} \right)^{n-1} \quad (\text{D.3})$$

where the quantities with subscripts refer to the values at the test conditions and those without to values at the standard air conditions, and where

$$\rho_{1,20} = 1,1988 \text{ kg/m}^3 \text{ (0,075 lbf/ft}^3\text{)},$$

$$\mu_{1,20} = 18,097 \times 10^{-6} \text{ Pa}\cdot\text{s (4,021} \times 10^{-7} \text{ lbf}\cdot\text{s/ft}^2\text{)}$$

Exponent  $n$  is usually determined only for a clean filter. During the dust loading phase,  $n$  can change. As it is undesirable to measure pressure loss curves after each dust loading phase, the initial value of  $n$  may be used during the filter test. Air density  $\rho$  (kg/m<sup>3</sup> or lbf/ft<sup>3</sup>) at temperature  $T$  (°C or °F), barometric pressure  $p$  (Pa, lbf/in<sup>2</sup>) and relative humidity  $\varphi$  (%) can be obtained using Equation (D.4), and the result expressed in metric units, and using (D.5) for a result expressed in imperial units:

$$\rho = \frac{p - 0,378 p_w}{287,06 (T + 273,15)} \quad (\text{D.4})$$

$$\rho = \frac{p - 0,378 p_w}{287,06 (T + 459,67)} \quad (\text{D.5})$$

where  $p_w$  (Pa or lbf/in<sup>2</sup>) is the partial vapour pressure of water in air given by Equation (D.6) for metric or imperial units:

$$p_w = \frac{\varphi}{100} p_{ws} \quad (\text{D.6})$$

and where  $p_{ws}$  (Pa or lbf/in<sup>2</sup>) is the saturation vapour pressure of water in air at temperature  $T$  (°C or °F) obtained from Equation (D.7) for metric units and Equation (D.8) for imperial units:

$$p_{ws} = \exp \left[ 59,484\,085 - \frac{6\,790,498\,5}{T + 273,15} - 5,028\,02 \times \ln(T + 273,15) \right] \quad (\text{D.7})$$

$$p_{ws} = 0,004\,01 \exp \left[ 59,484\,085 - \frac{6\,790,498\,5}{T/1,8 + 255,73} - 5,028\,02 \times \ln(T/1,8 + 255,73) \right] \quad (\text{D.8})$$

Dynamic viscosity  $\mu$  (Pa·s or lbf·s/ft<sup>2</sup>) at temperature  $T$  (°C or °F) can be obtained from Equation (D.9) for metric units and Equation (D.10) for imperial units:

$$\mu = \frac{1,455 \times 10^{-6} (T + 273,15)^{0,5}}{1 + 110,4/T + 273,15} \quad (\text{D.9})$$

$$\mu = 3,62 \times 10^{-7} \left[ (T + 459,67)/518,7 \right]^{1,5} \left[ 717,42/(T + 658,39) \right] \quad (\text{D.10})$$

## Bibliography

- [1] ANSI/ASHRAE 52.2:2007, *Method of Testing General Ventilation Air-Cleaning Devices for Removal Efficiency by Particle Size*<sup>3)</sup>
- [2] ASME Standard MFC-3M-1985, *Measurement of Fluid Flow in Pipes Using Orifice, Nozzle and Venturi*<sup>4)</sup>
- [3] ASTM-F328-98, *Standard Practice for Calibration of an Airborne Particle Counter Using Monodisperse Spherical Particles*<sup>5)</sup>
- [4] ASTM-F649-80, *Standard Practice for Secondary Calibration of Airborne Particle Counter Using Comparison Procedures*
- [5] EN 779:2002, *Particulate air filters for general ventilation — Determination of the filtration performance*
- [6] EN 1822-3, *High efficiency air filters (HEPA and ULPA) — Part 3: Testing flat sheet filter media*
- [7] IEST-RP-CC014:2006, *Calibrating Particle Counters*<sup>6)</sup>
- [8] JACA No. 37-2001, *Guideline of Substitute Materials for DOP*
- [9] JIS Z 8901:2006. *Test powders and test particles: Test particle 2, 8.1 a) poly-alpha olefins with specific gravity between 0,80 to 0,82 and kinematic viscosity between 3,8 to 4,1 mm<sup>2</sup>/s (100 °C)*
- [10] BARON, P., WILLEKE, K. *Aerosol Measurement: Principles, Techniques, and Applications*, 2nd Edition, Wiley-Interscience, 2005
- [11] Eurovent 4/9:1997, *Method of testing air filters used in general ventilation for determination of fractional efficiency*<sup>7)</sup>
- [12] HINDS, W.C. *Aerosol Technology: Properties, Behavior and Measurement of Airborne Particles*, Wiley-Interscience, 1999
- [13] ISO 14644-3: *Clean rooms and associated controlled environments — Part 3: Test Methods*
- [14] KUEHN, T.H., YANG, C.H. and KULP R. H. Effects of Fan Cycling on the Performance of Particulate Air filters used for IAQ Control. Indoor Air '96, *The 7th International Conference on Indoor Air Quality and Climate*, Vol. 4, p 211
- [15] Nordtest NT VVS 117:1998, *Test method for electret filters — Determination of the electrostatic enhancement factor of filter media*
- [16] PHILLIPS, B.A., DAVIS, W.T. and DEVER, M. Investigation of the Effect of a Topically Applied Tackifier in Reducing Particle Bounce in a Melt-Blown Air Filter. *Filtration & Separation*, 1996, p 933

---

3) American National Standards Institute/American Society of Heating, Refrigerating and Air Conditioning Engineers

4) American Society of Mechanical Engineers

5) American Society for Testing and Materials

6) Institute of Environmental Sciences and Technology

7) European Committee of Air Handling and Refrigeration Equipment Manufacturers

- [17] REICHERT, F., OHDE, A. Untersuchung zur Freisetzung von Filterfasern und zur Ablösung von schadstoffbelasteten Partikeln durch Luftfilter in RLT-Anlagen unter besonderer Berücksichtigung der in der Praxis auftretenden Schwingungszustände. Abschlussbericht zum bmb+f Forschungsvorhaben FKZ 1701199, FHTW Berlin 2002
- [18] REICHERT, F., OHDE, A. Untersuchungen des Fasershedding an typgeprüften Feinstaubtaschenfiltern in Raumluftechischen Anlagen. *Colloquium Filtertechnik* 2004, Universität Karlsruhe
- [19] RIVERS, R.D. and MURPHY, D.J. *Determination of Air Filter Performance under Variable Air Volume (VAV) Conditions*. ASHRAE 675-RP:1996
- [20] QIAN, Y., WILLEKE, K., ULEVICIUS, V. and GRINSHPUN, S.A. Particle Re-entrainment from Fibrous Filters. *Aerosol Science and Technology*, 27:3



---

---

**ICS 13.040.20**

Price based on 54 pages





---

## BSI - British Standards Institution

BSI is the independent national body responsible for preparing British Standards. It presents the UK view on standards in Europe and at the international level. It is incorporated by Royal Charter.

### Revisions

British Standards are updated by amendment or revision. Users of British Standards should make sure that they possess the latest amendments or editions.

It is the constant aim of BSI to improve the quality of our products and services. We would be grateful if anyone finding an inaccuracy or ambiguity while using this British Standard would inform the Secretary of the technical committee responsible, the identity of which can be found on the inside front cover. Tel: +44 (0)20 8996 9000. Fax: +44 (0)20 8996 7400.

BSI offers members an individual updating service called PLUS which ensures that subscribers automatically receive the latest editions of standards.

### Buying standards

Orders for all BSI, international and foreign standards publications should be addressed to Customer Services. Tel: +44 (0)20 8996 9001. Fax: +44 (0)20 8996 7001 Email: [orders@bsigroup.com](mailto:orders@bsigroup.com) You may also buy directly using a debit/credit card from the BSI Shop on the Website <http://www.bsigroup.com/shop>

In response to orders for international standards, it is BSI policy to supply the BSI implementation of those that have been published as British Standards, unless otherwise requested.

### Information on standards

BSI provides a wide range of information on national, European and international standards through its Library and its Technical Help to Exporters Service. Various BSI electronic information services are also available which give details on all its products and services. Contact Information Centre. Tel: +44 (0)20 8996 7111 Fax: +44 (0)20 8996 7048 Email: [info@bsigroup.com](mailto:info@bsigroup.com)

Subscribing members of BSI are kept up to date with standards developments and receive substantial discounts on the purchase price of standards. For details of these and other benefits contact Membership Administration. Tel: +44 (0)20 8996 7002 Fax: +44 (0)20 8996 7001 Email: [membership@bsigroup.com](mailto:membership@bsigroup.com)

Information regarding online access to British Standards via British Standards Online can be found at <http://www.bsigroup.com/BSOL>

Further information about BSI is available on the BSI website at <http://www.bsigroup.com>

### Copyright

Copyright subsists in all BSI publications. BSI also holds the copyright, in the UK, of the publications of the international standardization bodies. Except as permitted under the Copyright, Designs and Patents Act 1988 no extract may be reproduced, stored in a retrieval system or transmitted in any form or by any means – electronic, photocopying, recording or otherwise – without prior written permission from BSI.

This does not preclude the free use, in the course of implementing the standard, of necessary details such as symbols, and size, type or grade designations. If these details are to be used for any other purpose than implementation then the prior written permission of BSI must be obtained.

Details and advice can be obtained from the Copyright and Licensing Manager. Tel: +44 (0)20 8996 7070 Email: [copyright@bsigroup.com](mailto:copyright@bsigroup.com)