

Hydrometry — Functional requirements and characteristics of suspended-sediment samplers

ICS 17.120.20

National foreword

This Draft for Development was published by BSI. It is the UK implementation of ISO/TS 3716:2006.

This publication is not to be regarded as a British Standard.

It is being issued in the Draft for Development series of publications and is of a provisional nature. It should be applied on this provisional basis, so that information and experience of its practical application can be obtained.

Comments arising from the use of this Draft for Development are requested so that UK experience can be reported to the international organization responsible for its conversion to an international standard. A review of this publication will be initiated not later than 3 years after its publication by the international organization so that a decision can be taken on its status.

Notification of the start of the review period will be made in an announcement in the appropriate issue of *Update Standards*.

According to the replies received by the end of the review period, the responsible BSI Committee will decide whether to support the conversion into an international Standard, to extend the life of the Technical Specification or to withdraw it. Comments should be sent to the Secretary of the responsible BSI Technical Committee at British Standards House, 389 Chiswick High Road, London W4 4AL.

The UK participation in its preparation was entrusted to Technical Committee CPI/113, Hydrometry.

A list of organizations represented on CPI/113 can be obtained on request to its secretary.

This publication does not purport to include all the necessary provisions of a contract. Users are responsible for its correct application.

This Draft for Development was published under the authority of the Standards Policy and Strategy Committee on 31 October 2006

© BSI 2006

ISBN 0 580 49389 X

Amendments issued since publication

Amd. No.	Date	Comments

TECHNICAL
SPECIFICATION

ISO/TS
3716

First edition
2006-08-15

**Hydrometry — Functional requirements
and characteristics of suspended-
sediment samplers**

*Hydrométrie — Spécifications de fonctionnement et caractéristiques
des appareils d'échantillonnage pour la détermination des charges
sédimentaires en suspension*



Reference number
ISO/TS 3716:2006(E)

Contents

Page

Foreword.....	iv
Introduction	v
1 Scope	1
2 Normative references	1
3 Terms and definitions	1
4 Requirements of samplers	1
5 Characteristics of suspended-sediment samplers	3
6 Types of samplers	3
6.1 Open containers	3
6.2 Vertical and horizontal cylinders	4
6.3 Bottle samplers	4
6.4 Pumping samplers	5
6.5 Single-stage samplers	6
6.6 Point-integrating samplers	7
6.7 Depth-integrating samplers	8
6.8 Clean samplers	8
7 Models of samplers	9
Bibliography	11

Foreword

ISO (the International Organization for Standardization) is a worldwide federation of national standards bodies (ISO member bodies). The work of preparing International Standards is normally carried out through ISO technical committees. Each member body interested in a subject for which a technical committee has been established has the right to be represented on that committee. International organizations, governmental and non-governmental, in liaison with ISO, also take part in the work. ISO collaborates closely with the International Electrotechnical Commission (IEC) on all matters of electrotechnical standardization.

International Standards are drafted in accordance with the rules given in the ISO/IEC Directives, Part 2.

The main task of technical committees is to prepare International Standards. Draft International Standards adopted by the technical committees are circulated to the member bodies for voting. Publication as an International Standard requires approval by at least 75 % of the member bodies casting a vote.

In other circumstances, particularly when there is an urgent market requirement for such documents, a technical committee may decide to publish other types of normative document:

- an ISO Publicly Available Specification (ISO/PAS) represents an agreement between technical experts in an ISO working group and is accepted for publication if it is approved by more than 50 % of the members of the parent committee casting a vote;
- an ISO Technical Specification (ISO/TS) represents an agreement between the members of a technical committee and is accepted for publication if it is approved by 2/3 of the members of the committee casting a vote.

An ISO/PAS or ISO/TS is reviewed after three years in order to decide whether it will be confirmed for a further three years, revised to become an International Standard, or withdrawn. If the ISO/PAS or ISO/TS is confirmed, it is reviewed again after a further three years, at which time it must either be transformed into an International Standard or be withdrawn.

Attention is drawn to the possibility that some of the elements of this document may be the subject of patent rights. ISO shall not be held responsible for identifying any or all such patent rights.

ISO/TS 3716 was prepared by Technical Committee ISO/TC 113, *Hydrometry*, Subcommittee SC 6, *Sediment transport*.

This first edition of ISO/TS 3716 cancels and replaces ISO 3716:1977, which has been technically revised.

Introduction

Suspended-sediment samplers are used to collect a representative sample of the water-sediment mixture of rivers and streams. Ideally, the sampler should be able to collect samples that represent the mean concentration of suspended sediment or define the horizontal and vertical variation of suspended-sediment concentration so that the mean concentration can be determined. Samplers have gradually evolved from those that collect an instantaneous sample at one point in a stream or river to streamlined samplers that collect time and/or depth-integrated samples. There are a number of different types of samplers available for collecting suspended sediment, including open containers, vertical and horizontal cylinders, bottle samplers, pumping samplers, single-stage samplers, point-integrating samplers and depth-integrating samplers. Some samplers have also been adapted to enable the collection of clean (uncontaminated) samples of trace metal and organic compounds that are commonly associated with suspended sediment in streams and rivers.

Hydrometry — Functional requirements and characteristics of suspended-sediment samplers

1 Scope

This Technical Specification specifies the functional requirements and characteristics of the different types of suspended-sediment samplers.

NOTE The units of measurement used in this Technical Specification are SI units.

2 Normative references

The following referenced documents are indispensable for the application of this document. For dated references, only the edition cited applies. For undated references, the latest edition of the referenced document (including any amendments) applies.

ISO 772, *Hydrometric determinations — Vocabulary and symbols*

3 Terms and definitions

For the purposes of this document, the terms and definitions given in ISO 772 and the following apply.

3.1

isokinetic

intake velocity of the suspended-sediment sampler equals the ambient stream velocity

4 Requirements of samplers

In order that the samples taken by a sampler are truly representative of the sediment concentration of a stream at a point of sampling, the ideal sampler should fulfil the following technical requirements.

- a) The sampler shall be streamlined to reduce drag and to minimize disturbances to normal sediment flow.
- b) The velocity of inflow in the mouth of the sampler, nozzle or sampling tube shall be isokinetic or as close as possible to the velocity of the current of water at the sampling point, irrespective of what this velocity may be or irrespective of what the depth of submergence at this point may be. This aspect is most important if large sampling errors are to be avoided.
- c) The mouth/intake of the sampler shall always face into the current at the sampling point.
- d) The mouth/intake of the sampler shall be outside the zone of the disturbances of the flow set up by the body of the sampler and its operating gear, and the flow lines shall be disturbed as little as possible, especially near the mouth.

- e) Filling arrangements shall be smooth so that there is no sudden inrush of water-sediment mixture; the air escaping from the sampler shall not hinder the entry of the sample; this necessitates a separate port for air exhaust.
- f) The sampler shall be able to collect samples at the desired depth without the samples being disturbed or contaminated by the water-sediment mixture at other points while the sampler is being raised or lowered.
- g) It shall be possible to take a sample exactly when and where it is required, in particular when sampling close to the streambed.
- h) The sampler shall be portable, yet sufficiently heavy to minimize deflection of the supporting cable from the vertical due to current drag.
- i) The sampler shall be simple in design and robust in construction and shall require minimum care in maintenance and operation.
- j) The removable-type container within the sampler shall be easily removed, readily capped or sealed and easily transported to a laboratory without loss of contents. Alternatively, if the container forms part of the sampler, it shall be installed so as to secure complete drainage of the contents.
- k) The volume of the sample collected by the sampler shall be sufficient for determining the concentration and size distribution of the sediment. The minimum sample size is generally 0,5 l.
- l) Depth-integrating samplers should be lowered or raised at a uniform and slow speed, a fraction of the current velocity (for example, between 1/15 and 2/5 – see Note).

NOTE Depth integration (with uniform vertical motion – see Figure 1):

$$A \cdot v \cdot t = V, \text{ assuming } v = v_n \quad (1)$$

$$i = k \cdot v, \text{ where } k = v_n/v \quad (2)$$

$$h = i \cdot t \quad (3)$$

where

- A is the area of the mouth or tube;
- v is the current velocity;
- v_n is the velocity in the mouth/intake (nozzle) of the sampler;
- t is the maximum duration of sampling;
- V is the sample volume to be taken;
- i is the uniform rate for sampler movement;
- k is the transit rate ratio;
- h is the maximum vertical distance for sampling.

From Equations (1), (2) and (3):

$$h = k \frac{V}{A} \quad (4)$$

For example, with $A = 28,3 \text{ mm}^2$ ($\Phi 6 \text{ mm}$), $k = 1/10$ and $V = 0,5 \text{ l}$, the maximum depth of sampling is 1,76 m. If the flow depth is greater, sampling should be done with two or more sections in the vertical.

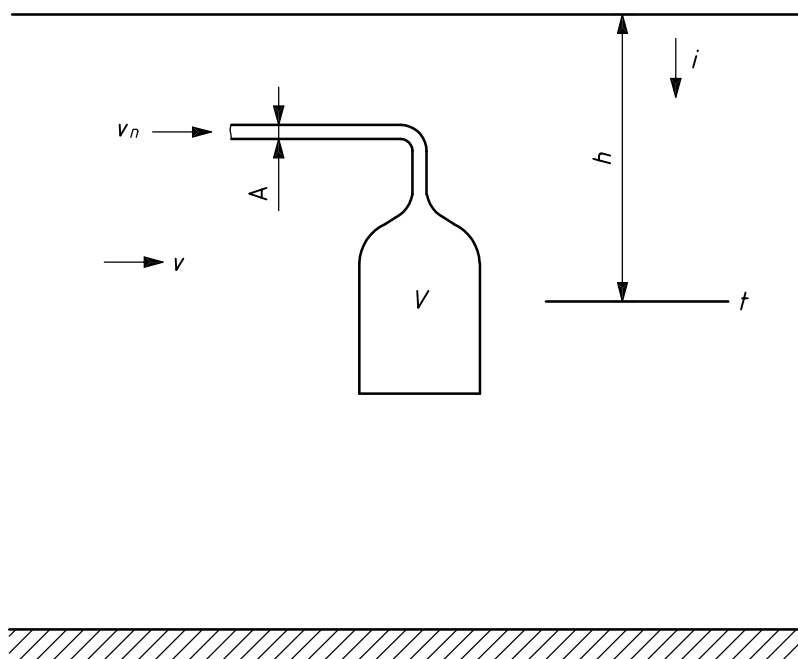
**Key**

- A area of the mouth or tube
- v current velocity
- v_n velocity in the mouth/intake (nozzle) of the sampler
- t maximum duration of sampling
- V sample volume to be taken
- i uniform rate for sampler movement
- h maximum vertical distance for sampling

Figure 1 — Schematic diagram of a suspended-sediment sampler and the factors affecting sample volume

5 Characteristics of suspended-sediment samplers

Since the sampling conditions encountered in streams vary widely, a single sampler for all the conditions cannot be recommended. Factors such as availability, cost and specific requirements of the sampling also influence the choice of the sampler to a great extent. The different types of samplers include open containers, vertical and horizontal cylinders, bottle samplers, pumping samplers, single-stage samplers, point-integrating samplers and depth-integrating samplers. All of these types of samplers can collect a representative sample of the water-sediment mixture in a river or stream under the right conditions, but many of them cannot be used in rivers with swift currents and a non-uniform distribution of sediment concentration. For general use in rivers and streams, point-integrating and depth-integrating samplers are recommended. The use of trade, product or firm names in this document is for descriptive purposes only and does not imply endorsement.

6 Types of samplers

6.1 Open containers

This type of sampler consists of an ordinary pail, can or open bottle. The sample is collected by holding the container under the surface of the water or by lowering it to the water surface with a rope or cable. The filled container can be sealed for transport and subsequent analysis or the sample can be transferred into another container that can be sealed.

The limitation of these samplers is that they can only collect a sample at the water surface. Representative samples will be collected only if the water-sediment mixture is thoroughly mixed and free of silt and sand.

6.2 Vertical and horizontal cylinders

These samplers (see Figure 2) are typically made of steel, brass or plastic. They are made in various diameters and lengths. The cylinder is lowered to the desired sampling point with the valves at each end of the cylinder in the open position. The sample is collected by closing the valves and retrieving the cylinder. The valves are actuated by an electrical impulse or by sending a weight down the suspension cable to trip spring-loaded valves. The sample is typically transferred to another container so the cylinder can be reused.

These samplers, particularly the vertical cylinders, offer considerable resistance to flow and are only stable at very low velocities. Vertical cylinders cannot sample close to the streambed. Horizontal samplers can sample near the streambed.

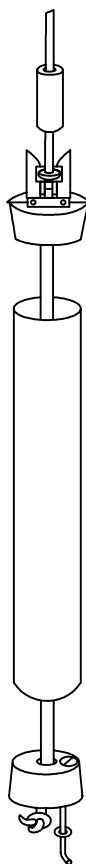

Figure 2 — Kemmerer sampler

6.3 Bottle samplers

There are many different variations of bottle samplers. They generally consist of a weighted container to hold a 0,5 l to 2 l sample bottle. The sampler is lowered to the desired depth by a rope or cable and then the cap is removed from the bottle to collect the sample. Some models have the capability of both opening and closing the bottle cap so the sample is sealed and no intermixing of the sample with the water-sediment mixture in the river occurs while the sampler is being retrieved.

These samplers offer considerable resistance to flow and are only stable at very low velocities. Samples cannot typically be collected close to the streambed. The potential for intermixing of the sample and water-sediment mixture in the river is high for those samplers that cannot be sealed at the sampling point.

6.4 Pumping samplers

6.4.1 General

There are two types of pumping samplers used for collecting suspended-sediment samples: those with a fixed orifice that are operated in automatic mode and those with a moveable orifice that are deployed from a boat, walkway or bridge.

6.4.2 Fixed-orifice samplers

Fixed-orifice samplers (Figure 3) typically are used at sites where personnel are not available to take samples manually, such as ephemeral and flashy streams or streams in isolated locations. The orifice is typically located at or near the stream bank. The samplers are powered with line power or batteries, and samples are pumped from the stream to sample containers. The first phase of sampling is back flushing to prime the pump and flush accumulated sediment from the orifice line. Sampling frequency is controlled on the basis of both time and stage so that samples can be collected at one interval during low flow and more frequently during high flow.

The fixed-orifice samplers are an effective method of collecting samples when personnel are not available for collecting manual samples. However, the samples only represent the suspended-sediment concentration at one point in one vertical of the stream and a correction factor is required to determine the mean suspended-sediment concentration. Samples also are subject to evaporation until they are sealed and removed for analysis.

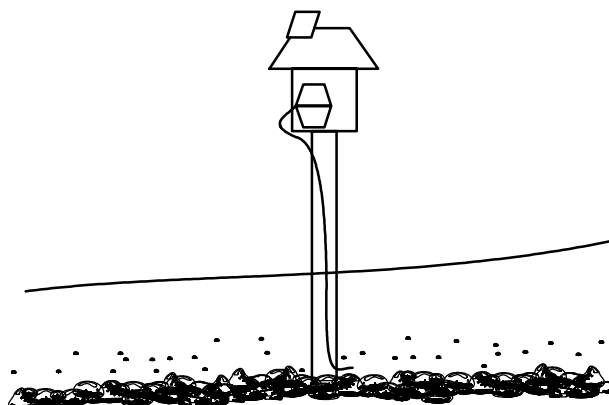

Figure 3 — Diagram of a fixed-orifice pumping sampler

6.4.3 Moveable-orifice samplers

These are usually used to collect large-volume samples for analyses of suspended sediment and other constituents. A pump on a boat or other platform above the water surface is used to create a vacuum to raise the water-sediment mixture to a sample container on the boat or work platform. An orifice line is lowered to the desired sampling depth to obtain the sample. The orifice also can be lowered during sampling to collect a depth-integrated sample. A submersible pump can also be lowered on a cable, and then the sample is pumped to containers on the platform or vessel (Figure 4). Some units are equipped with a velocity sensor to automatically adjust the pump speed to collect an isokinetic sample. Alternatively, it is possible to measure the velocity at the point of sampling by current meter and then manually adjust the rate of pumping to match the velocity of sampling with the stream velocity.

These samplers are good for collecting large-volume samples, but the combination of the orifice line and the weight to hold the orifice in place offer much resistance to flow. The vacuum pump versions of these samplers are limited to collecting samples to a depth of about 7 m because of the efficiency of vacuum pumps.

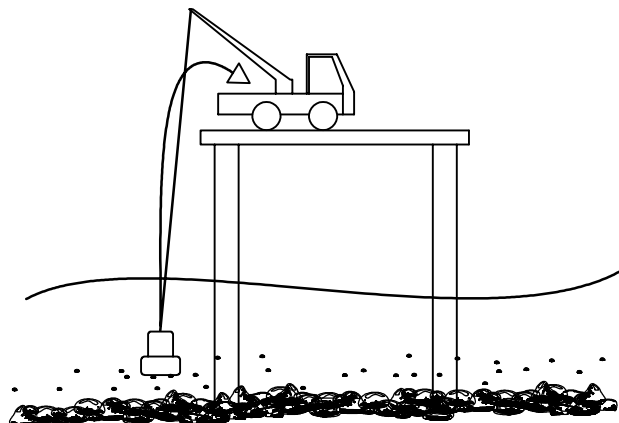

Figure 4 — Diagram of the submersible-pump version of a moveable-orifice pumping sampler

6.5 Single-stage samplers

Single-stage samplers are an inexpensive and effective means of collecting sediment samples on intermittent and flashy streams and at remote locations. The sampling unit consists of a bottle with an intake tube and an exhaust tube (Figure 5). The orifice and inverts of the tubes are positioned to collect a representative sample a few centimetres below the water surface; re-circulation within the bottle is prevented by the air lock that occurs between the inverts of the intake and exhaust tubes. Several units may be mounted at different positions on a vertical support to collect samples as the water level rises during a runoff event. After the peak passes, the bottles are removed and sealed for transport and subsequent analysis.

These samplers can only collect near-surface samples during rising stages. Samplers are generally located near the stream bank for ease of servicing and to avoid heavy debris. Sample concentrations will only be representative of the mean concentration of the sediment in the stream if the water-sediment mixture is very well mixed with most particles finer than 0,062 mm.

Dimensions in millimetres

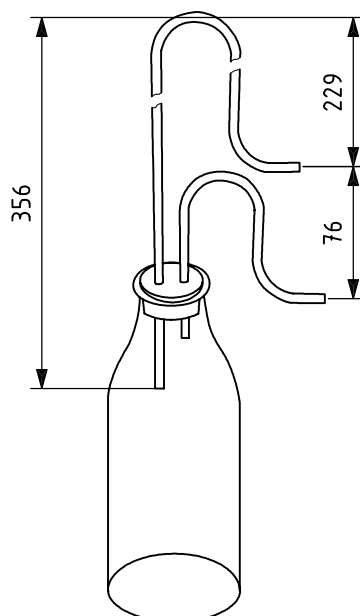

Figure 5 — Schematic diagram of a typical single-stage sediment sampler

6.6 Point-integrating samplers

There are a number of different models and sizes of point-integrating sediment samplers. They generally consist of a bronze or aluminium, streamlined body with tail vanes for stability in high currents (Figure 6). They are raised and lowered in the river with a reel and cable assembly. Water enters through a nozzle at the nose of the sampler body, and the sample is collected in a bottle or other container within the sampler. Some samplers have interchangeable nozzles that are used depending on the flow velocity and river depth. The containers, which are usually 0,5 l or 1 l glass or plastic bottles, are removed from the sampler and sealed for shipment and analysis. The sampler includes an opening and closing mechanism that allows samples to be collected at any depth after equalizing the pressure inside the sampler with the pressure at the depth of sampling to ensure isokinetic sampling.



Figure 6 — US P-61-A1 suspended-sediment sampler developed by the Federal Interagency Sedimentation Project in the United States

These samplers also are used for collecting depth-integrated samples.

- For depths up to 5 m, the sampler can be lowered and raised with the valve open.
- For depths greater than 5 m, the sampler can be lowered and raised at different increments of depth and samples can be combined to obtain a mean suspended-sediment concentration for the vertical.

For example, with a depth of 10 m, a point sampler can be used to collect 2 samples. Lowering and raising the sampler with the valve open to a depth of 5 m would collect the first sample; lowering the sampler to 5 m with the valve closed and then lowering and raising it between 5 m and 10 m with the valve open would collect the second sample.

6.7 Depth-integrating samplers

Depth-integrating samplers are very similar to point-integrating samplers. They have streamlined bodies with a nozzle at the nose and tail vanes for stability. They do not have a valve for opening and closing the nozzle. These samplers include those that are attached to a wading rod, those that are raised and lowered by hand with a rope, and those that are raised and lowered by a reel and cable assembly. There are two types of depth-integrating samplers: those that contain rigid containers and those that contain a plastic or fluoropolymer bag. The samplers that contain rigid containers are limited to a sampling depth of 5 m in order to maintain isokinetic sampling and avoid overfilling of the containers.

A newer type of depth-integrating sampler has a plastic or fluoropolymer bag instead of a bottle for the samples. All the air is evacuated from the bag before the sampler is lowered in the river so the depth of sampling is not restricted by the compression of air in the container. The US D-96 (Figure 7) sampler developed by the Federal Interagency Sedimentation Project in the United States can be used for collecting depth-integrated samples to a depth of 15 m to 30 m depending on the size of nozzle used. When the sampler is retrieved, either the sample is transferred from the bag to another container or the bag is sealed and placed in another container for shipment to the laboratory.



Figure 7 — US D-96 bag sampler developed by the Federal Interagency Sedimentation Project

The depth-integrating and point-integrating samplers are the only samplers that will collect a representative sample of the water-sediment mixture in deep, swift rivers.

6.8 Clean samplers

Variations of depth-integrating sediment samplers are special samplers for collecting water-sediment mixtures for chemical analyses. These samplers are very similar to the suspended-sediment samplers, except they are equipped with fluoropolymer and plastic components so the samples will not be in contact with any metal. The DH-95 sampler (Figure 8) uses 1 l fluoropolymer or plastic bottles with nozzles that are integral with the bottle caps.

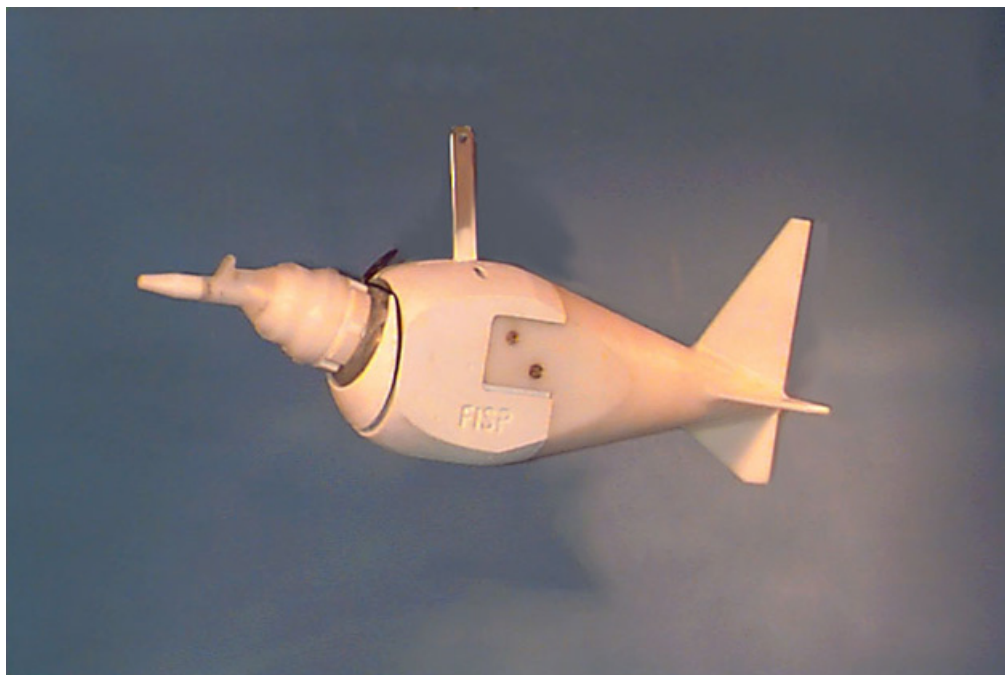

Figure 8 — US DH-95 sampler developed by the Federal Interagency Sedimentation Project

7 Models of samplers

The following table is a summary of the most widely used suspended-sediment samplers today.

Table 1 — Models of samplers in use in different countries

Sampler type	Model name ^a	Countries of use	Mass in kilograms	Method of suspension	Sample size in litres
Open container		Japan, India, USA	Variable	Hand or rope	Variable
Vertical or horizontal cylinder	Kemmerer	USA		Rope or cable	
	Niskin	Netherlands	2,5	Rope	1,7
	Vertical pipe	India, UK		Rope	1
Bottle	Punjab	India		Rope	
	US WBH-96	USA		Rope or cable	1
Pumping	ISCO 1680	Germany, Japan, Netherlands, Switzerland, USA		Streambank shelter	0,5
	Lift pump	Germany, Japan, Netherlands, Switzerland, USA		Cable	Many litres
	Manning PST		11,1	Streambank shelter	1
	Manning VST	USA	11,1	Streambank shelter	1
	Suspended water pump	Germany, Japan, Netherlands, Switzerland		Cable	Many litres

^a The majority of the models listed are examples of suitable products available commercially. This information is given for the convenience of users of this Technical Specification and does not constitute an endorsement by ISO of these products.

Table 1 (continued)

Sampler type	Model name ^a	Countries of use	Mass in kilograms	Method of suspension	Sample size in litres
Single-stage	US U-59	USA	1		0,5
Point-integrating	ASP 2000	Germany, Netherlands, Switzerland			0,5
	ASPEG	Germany, Netherlands, Switzerland			
	AYX Pressure Equalizing Sampler	China	100, 150 and 300	Cable	2,5
	ANX3 Bag Sampler	China	100, 200, 300 and 400	Cable	3
	Delft Bottle	Netherlands		Cable	
	P 50	India		Cable	0,5
	Turbidisonde	France	92	Cable	
	US P-61-A1	USA	48,5	Cable	0,5 or 1
	US P-63	USA	91,6	Cable	0,5 or 1
	US P-72	USA	18,6	Cable	0,5 or 1
Depth-integrating	APX Bottle Sampler	China	100 and 150	Cable	2,5
	Collapsible Bag	Netherlands		Cable	5 to 10
	D 49	India		Cable	0,5
	Horizontal Bottle	Russia		Cable	
	LS Bag Sampler	China	75, 150 and 250	Cable	3 or 5
	PWRI	Japan		Cable	
	SGS M266 D/10	Germany, Netherlands, Switzerland	1,3	Rod	1
	State Hydrological Institute	Russia		Cable	
	TOHOKU	Japan		Cable	
	US DH-48	USA	1,6	Rod	0,5
	US DH-59	USA	10	Rope	0,5
	US DH-76	USA	11,3	Rope	1
	US DH-81	USA	1,0	Hand	1
	US DH-95	USA	13,1	Rope	1
	US D-74	USA	28,1	Cable	2,7
	US D-77	USA	34	Cable	2,7
	US D-95	USA	29	Cable	1
US D-96	USA	61	Cable	3	
1970 SGLN	Germany, Netherlands, Switzerland	8	Cable	1	

^a The majority of the models listed are examples of suitable products available commercially. This information is given for the convenience of users of this Technical Specification and does not constitute an endorsement by ISO of these products.

Bibliography

- [1] ISO 4363, *Measurement of liquid flow in open channels — Methods for measurement of characteristics of suspended sediment*
- [2] ISO 4365, *Liquid flow in open channels — Sediment in streams and canals — Determination of concentration, particle size distribution and relative density*

BSI — British Standards Institution

BSI is the independent national body responsible for preparing British Standards. It presents the UK view on standards in Europe and at the international level. It is incorporated by Royal Charter.

Revisions

British Standards are updated by amendment or revision. Users of British Standards should make sure that they possess the latest amendments or editions.

It is the constant aim of BSI to improve the quality of our products and services. We would be grateful if anyone finding an inaccuracy or ambiguity while using this British Standard would inform the Secretary of the technical committee responsible, the identity of which can be found on the inside front cover.
Tel: +44 (0)20 8996 9000. Fax: +44 (0)20 8996 7400.

BSI offers members an individual updating service called PLUS which ensures that subscribers automatically receive the latest editions of standards.

Buying standards

Orders for all BSI, international and foreign standards publications should be addressed to Customer Services. Tel: +44 (0)20 8996 9001.
Fax: +44 (0)20 8996 7001. Email: orders@bsi-global.com. Standards are also available from the BSI website at <http://www.bsi-global.com>.

In response to orders for international standards, it is BSI policy to supply the BSI implementation of those that have been published as British Standards, unless otherwise requested.

Information on standards

BSI provides a wide range of information on national, European and international standards through its Library and its Technical Help to Exporters Service. Various BSI electronic information services are also available which give details on all its products and services. Contact the Information Centre.
Tel: +44 (0)20 8996 7111. Fax: +44 (0)20 8996 7048. Email: info@bsi-global.com.

Subscribing members of BSI are kept up to date with standards developments and receive substantial discounts on the purchase price of standards. For details of these and other benefits contact Membership Administration.
Tel: +44 (0)20 8996 7002. Fax: +44 (0)20 8996 7001.
Email: membership@bsi-global.com.

Information regarding online access to British Standards via British Standards Online can be found at <http://www.bsi-global.com/bsonline>.

Further information about BSI is available on the BSI website at <http://www.bsi-global.com>.

Copyright

Copyright subsists in all BSI publications. BSI also holds the copyright, in the UK, of the publications of the international standardization bodies. Except as permitted under the Copyright, Designs and Patents Act 1988 no extract may be reproduced, stored in a retrieval system or transmitted in any form or by any means – electronic, photocopying, recording or otherwise – without prior written permission from BSI.

This does not preclude the free use, in the course of implementing the standard, of necessary details such as symbols, and size, type or grade designations. If these details are to be used for any other purpose than implementation then the prior written permission of BSI must be obtained.

Details and advice can be obtained from the Copyright & Licensing Manager.
Tel: +44 (0)20 8996 7070. Fax: +44 (0)20 8996 7553.
Email: copyright@bsi-global.com.