

DD IEC/PAS 62587:2008



BSI Standards Publication

Method for measuring performance of portable household electric room air cleaners

bsi.

...making excellence a habit.™

National foreword

This Draft for Development is the UK implementation of IEC/PAS 62587:2008.

This publication is not to be regarded as a British Standard.

a provisional nature. It should be applied on this provisional basis, so that information and experience of its practical application can be obtained.

A PAS is a Technical Specification not fulfilling the requirements for a standard, but made available to the public and established in an organization operating under a given procedure.

A review of this Draft for Development will be carried out not later than three years after its publication.

Notification of the start of the review period, with a request for the submission of comments from users of this Draft for Development, will be made in an announcement in the appropriate issue of Update Standards. According to the replies received, the responsible BSI Committee will judge whether the validity of the PAS should be extended for a further three years or what other action should be taken and pass their comments on to the relevant international committee.

Observations which it is felt should receive attention before the official call for comments will be welcomed. These should be sent to the Secretary of the responsible BSI Technical Committee at British Standards House, 389 Chiswick High Road, London W4 4AL.

The UK participation in its preparation was entrusted to Technical Committee CPL/59, Performance of household electrical appliances.

A list of organizations represented on this committee can be obtained on request to its secretary.

This publication does not purport to include all the necessary provisions of a contract. Users are responsible for its correct application.

© BSI 2009

ISBN 978 0 580 65622 4

ICS 13.040.20; 97.030

This Draft for Development was published under the authority of the Standards Policy and Strategy Committee on 31 January 2009

Amendments issued since publication

Amd. No.	Date	Text affected
-----------------	-------------	----------------------



PUBLICLY AVAILABLE SPECIFICATION

PRE-STANDARD

**Method for measuring performance of portable household electric room air
cleaners**





THIS PUBLICATION IS COPYRIGHT PROTECTED

Copyright © 2008 IEC, Geneva, Switzerland

All rights reserved. Unless otherwise specified, no part of this publication may be reproduced or utilized in any form or by any means, electronic or mechanical, including photocopying and microfilm, without permission in writing from either IEC or IEC's member National Committee in the country of the requester.

If you have any questions about IEC copyright or have an enquiry about obtaining additional rights to this publication, please contact the address below or your local IEC member National Committee for further information.

IEC Central Office
3, rue de Varembe
CH-1211 Geneva 20
Switzerland
Email: inmail@iec.ch
Web: www.iec.ch

About the IEC

The International Electrotechnical Commission (IEC) is the leading global organization that prepares and publishes International Standards for all electrical, electronic and related technologies.

About IEC publications

The technical content of IEC publications is kept under constant review by the IEC. Please make sure that you have the latest edition, a corrigenda or an amendment might have been published.

- Catalogue of IEC publications: www.iec.ch/searchpub

The IEC on-line Catalogue enables you to search by a variety of criteria (reference number, text, technical committee,...). It also gives information on projects, withdrawn and replaced publications.

- IEC Just Published: www.iec.ch/online_news/justpub

Stay up to date on all new IEC publications. Just Published details twice a month all new publications released. Available on-line and also by email.

- Electropedia: www.electropedia.org

The world's leading online dictionary of electronic and electrical terms containing more than 20 000 terms and definitions in English and French, with equivalent terms in additional languages. Also known as the International Electrotechnical Vocabulary online.

- Customer Service Centre: www.iec.ch/webstore/custserv

If you wish to give us your feedback on this publication or need further assistance, please visit the Customer Service Centre FAQ or contact us:

Email: csc@iec.ch
Tel.: +41 22 919 02 11
Fax: +41 22 919 03 00



PUBLICLY AVAILABLE SPECIFICATION

PRE-STANDARD

**Method for measuring performance of portable household electric room air
cleaners**

INTERNATIONAL
ELECTROTECHNICAL
COMMISSION

PRICE CODE



ICS 13.040.20

ISBN 2-8318-9932-X

CONTENTS

FOREWORD.....	3
INTRODUCTION.....	4
1 Scope.....	5
2 Normative references	6
3 Terms and definitions	6
4 General conditions for measurement	9
5 Test procedure for determining performance on cigarette smoke.....	11
6 Test procedure for determining performance on test dust	13
7 Test procedure for determining performance on paper mulberry pollen.....	14
8 Calculation procedures (see Annex D).....	16
9 Measurement of operating power.....	19
10 Measurement of standby power	19
11 Reporting	20
12 Safety.....	20
Annex A (normative) Details of test chamber construction and equipment.....	21
Annex B (normative) Sources of test materials (equivalent substitutes are acceptable).....	27
Annex C (informative) Standard laboratory operation procedures when testing portable room air cleaners	28
Annex D (informative) Standardization of calculations — Rounding procedures for data and calculations.....	31
Annex E (informative) Derivation of effective room size	32
Annex F (informative) Sample data	34
Annex G (informative) Test stand for wall mount and plug-in type air cleaners.....	40
Annex H (informative) Data acquisition — Sequence of steps and timelines.....	41
Figure A.1 – Air cleaner chamber.....	22
Figure G.1 – Test stand for wall mount and plug-in type air cleaners	40

INTERNATIONAL ELECTROTECHNICAL COMMISSION

**METHOD FOR MEASURING PERFORMANCE OF PORTABLE
HOUSEHOLD ELECTRIC ROOM AIR CLEANERS**

FOREWORD

- 1) The International Electrotechnical Commission (IEC) is a worldwide organization for standardization comprising all national electrotechnical committees (IEC National Committees). The object of IEC is to promote international co-operation on all questions concerning standardization in the electrical and electronic fields. To this end and in addition to other activities, IEC publishes International Standards, Technical Specifications, Technical Reports, Publicly Available Specifications (PAS) and Guides (hereafter referred to as "IEC Publication(s)"). Their preparation is entrusted to technical committees; any IEC National Committee interested in the subject dealt with may participate in this preparatory work. International, governmental and non-governmental organizations liaising with the IEC also participate in this preparation. IEC collaborates closely with the International Organization for Standardization (ISO) in accordance with conditions determined by agreement between the two organizations.
- 2) The formal decisions or agreements of IEC on technical matters express, as nearly as possible, an international consensus of opinion on the relevant subjects since each technical committee has representation from all interested IEC National Committees.
- 3) IEC Publications have the form of recommendations for international use and are accepted by IEC National Committees in that sense. While all reasonable efforts are made to ensure that the technical content of IEC Publications is accurate, IEC cannot be held responsible for the way in which they are used or for any misinterpretation by any end user.
- 4) In order to promote international uniformity, IEC National Committees undertake to apply IEC Publications transparently to the maximum extent possible in their national and regional publications. Any divergence between any IEC Publication and the corresponding national or regional publication shall be clearly indicated in the latter.
- 5) IEC provides no marking procedure to indicate its approval and cannot be rendered responsible for any equipment declared to be in conformity with an IEC Publication.
- 6) All users should ensure that they have the latest edition of this publication.
- 7) No liability shall attach to IEC or its directors, employees, servants or agents including individual experts and members of its technical committees and IEC National Committees for any personal injury, property damage or other damage of any nature whatsoever, whether direct or indirect, or for costs (including legal fees) and expenses arising out of the publication, use of, or reliance upon, this IEC Publication or any other IEC Publications.
- 8) Attention is drawn to the Normative references cited in this publication. Use of the referenced publications is indispensable for the correct application of this publication.
- 9) Attention is drawn to the possibility that some of the elements of this IEC Publication may be the subject of patent rights. IEC shall not be held responsible for identifying any or all such patent rights.

A PAS is a technical specification not fulfilling the requirements for a standard, but made available to the public.

IEC-PAS 62587 has been prepared by the Association of Home Appliance Manufacturers (AHAM) and processed by IEC technical committee 59: Performance of household and similar electrical appliances. It is based on ANSI/AHAM AC-1-2006

The text of this PAS is based on the following document:

This PAS was approved for publication by the P-members of the committee concerned as indicated in the following document

Draft PAS	Report on voting
59/499/PAS	59/506/RVD

Following publication of this PAS, which is a pre-standard publication, the technical committee or subcommittee concerned will transform it into an International Standard.

This PAS shall remain valid for an initial maximum period of 3 years starting from the publication date. The validity may be extended for a single 3-year period, following which it shall be revised to become another type of normative document, or shall be withdrawn.

INTRODUCTION

This Publicly Available Specification (PAS) contains test procedures for measuring the relative reduction by the air cleaner of particulate matter suspended in the air in a specified test chamber. It also prescribes a method for measuring the operating power and standby power of the air cleaner. The test procedures may be applied to any brand or model of portable household electric room air cleaners within the stated confines of the standard's limits of measurability for measuring performance.

The annexes to this PAS are included for informative purposes only unless the annexes are noted as normative.

This PAS may involve hazardous materials, operations, and equipment. This PAS does not purport to address all of the safety problems associated with its use. It is the responsibility of whoever uses this PAS to consult and establish appropriate safety and health practices and determine the applicability of any regulatory limitations prior to use.

METHOD FOR MEASURING PERFORMANCE OF PORTABLE HOUSEHOLD ELECTRIC ROOM AIR CLEANERS

1 Scope and object

This Publicly Available Specification establishes a system of uniform, repeatable procedures and standard methods for measuring specified product characteristics of portable household electric room air cleaners.

The standard methods provide a means to compare and evaluate different brands of portable household electric room air cleaners regarding characteristics significant to product use.

The standard methods of measurement are not intended to inhibit improvement and innovation in product testing, design or performance.

This standard method applies to portable household electric room air cleaners as defined in Clause 3.

This standard method includes definitions and safety characteristics of portable household electric room air cleaners of the types indicated.

This standard method measures the relative reduction by the air cleaner of particulate matter suspended in the air in a specified test chamber. It also prescribes a method for measuring the operating power and standby power of the air cleaner.

This standard method has defined limits of measurability based on the statistical accuracy of the methods. Based on a 95 % confidence limit (2 standard deviations), a clean air delivery rate (CADR) (see 3.5) cannot be distinguished between zero (0) and a CADR rating less than those CADR limits shown below. Therefore, this PAS only applies to air cleaners with minimum CADR ratings of:

Dust	CADR = 10 cfm
Cigarette smoke	CADR = 10 cfm
Pollen	CADR = 25 cfm

The maximum CADR values are determined based on theoretical maximum limits. The theoretical maximum limits are determined by the maximum number of initial available particles, the acceptable minimum number of available particles, an average background natural decay rate (from statistical study), the size of the chamber, and the available minimum experiment time. CADR values greater than those listed will not have the necessary statistical data required by this method. Therefore, the document only applies to air cleaners with maximum CADR ratings of:

Dust	CADR = 400 cfm
Cigarette smoke	CADR = 450 cfm
Pollen	CADR = 450 cfm

The precision of this document as based on a 0 CADR air cleaner expressed as 2 standard deviation limits (95 %) are:

Dust	CADR = ± 10 cfm
Cigarette Smoke	CADR = ± 10 cfm
Pollen	CADR = ± 25 cfm

2 Normative references

The following referenced documents are indispensable for the application of this document. For dated references, only the edition cited applies. For undated references, the latest edition of the referenced document (including any amendments) applies.

ASTM E747, *Standard Test Method for Determining Air Change in a Single Zone by Means of a Tracer Gas Dilution*

3 Terms and definitions

For the purposes of this document, the following terms and definitions apply.

3.1

aerosol spectrometer

device for measuring particle size distribution in room air (see Annex A)

3.2 Air circulating equipment

3.2.1

ceiling mixing fan

high volume ceiling fan used to mix the chamber during contaminant aerosol generation

3.2.2

recirculation fan

fan capable of producing between 300 cfm and 400 cfm and used for the purpose of maintaining a homogeneous environment within the chamber (as specified in Annex A)

3.3

aerodynamic particle size

classification of particle sizes as spheres of unit density based on terminal settling velocities

3.4

cigarette smoke diluter

device for reducing the concentration of cigarette smoke by a known factor to a level suitable for measurement

3.5

Clean Air Delivery Rate

CADR

measure of air cleaner performance by this test procedure.

NOTE Within the scope of this PAS, CADR is defined as the measure of the delivery of contaminant free air by a portable household electric room air cleaner, expressed in cubic feet per minute (cfm). More technically, clean air delivery rates are the rates of contaminant reduction in the test chamber when the unit is turned on, minus the rate of natural decay when the unit is not running, times the volume of the test chamber as measured in cubic feet (see 8.5). CADRs are always the measurement of a unit's performance as a complete system, and they have no linear relationship to air movement *per se* or to the characteristics of any particular particle removal methodology.

3.6 Design characteristics

3.6.1

fan with filter

air cleaners which operate with an electrical source of power and which contain a motor and fan for drawing air through a filter media

3.6.2

fan and electrostatic plates

air cleaners which operate with a fan with electrostatic plate or wires to electrostatically collect particulate matter; may include a filter(s)

3.6.3

fan filter with ion generator

air cleaners which incorporate an ion generator in addition to a fan and filter

3.6.4

ion generator

air cleaners which incorporate an ion generator only

3.6.5

other types

device which has the stated capability to reduce the concentration of particulate matter in a room

NOTE Such devices do not have to contain a fan and can incorporate any of the particle removal methods noted above.

3.7 Generators

3.7.1

aerosol generator

device which produces and disseminates liquid or solid particles that are suspended in air

3.7.2

cigarette smoke generator

aerosol generator which disseminates test cigarette smoke with particle sizes specified in 3.16.1 into the air.

3.7.3

dust generator

aerosol generator which disseminates test dust with particle sizes specified in 3.16.2 into the air

3.7.4

pollen generator

aerosol generator which disseminates test pollen with particle sizes specified in 3.16.3 into the air

3.8

High Efficiency Particulate Air filter

HEPA

air filter with greater than or equal to 99,97 % removal of dioctyl phthalate at 0,3 µm diameter

NOTE The fractional efficiency of such filters can be verified using Mil-Std-282 or IEST-RP-CC007.1.

3.9

natural decay

reduction of particulate matter due to the natural phenomena in the test chamber, principally agglomeration, surface deposition (including sedimentation), and air exchange

3.10

particulate matter removal

reduction of particle number concentration in air due to the operation of the air cleaner

3.11 Portable room air cleaners

3.11.1

portable household electric room air cleaner

electric appliance with the function of removing particulate matter from the air and which may be moved from room to room

3.11.2

floor type room air cleaner

designed to stand alone on the floor of a room and are designated as stand-alone floor models by the manufacturer

NOTE Appliances of this type are tested on the floor as close to the center of the chamber as possible.

3.11.3

table type room air cleaner

designed to set on a table or counter by the manufacturer

NOTE Appliances of this type are tested on the table stand at the center of the chamber.

3.11.4

wall type room air cleaner

designed either to attach to a wall and are designated as wall mountable by the manufacturer or as a plug-in unit

NOTE A wall type unit includes the appropriate wall mounting brackets or specifically designated instructions to mount the room air cleaner integrally to the wall (i.e. not a shelf). Appliances of this type are tested on the wall mount stand placed at the center of the chamber (see Figure G.1).

3.11.5

combination type room air cleaner

designed to operate in one or more orientations/positions (floor, table, wall) as designed by the manufacturer

NOTE A combination type room air cleaner may be tested at the center of the room on either the floor, table, or wall mount stand, according to how it has been designated by the manufacturer (see 3.11.2, 3.11.3, 3.11.4).

3.11.6

ceiling type room air cleaner

designed to be mounted on the ceiling and are considered outside the scope of this method as defined in Clause 3

NOTE Uniform testing practices and statistical examination of such appliances have not been conducted.

3.11.7

plug-in type room air cleaner

fixed location appliance directly connected to an electric receptacle (outlet) by means of direct plug-in (no electric cord)

NOTE Appliances of this type are tested at the lower level electrical receptacle of the plug-in type test stand as shown in Figure G.1.

3.12

particle number concentration

number of particles per cubic centimeter of room air

3.13

room size

maximum suggested room size for an air cleaner

NOTE The room size is determined by mathematical modelling of steady state and is based on the CADR requirement to remove 80 % of cigarette smoke particles between 0,1 micron and 1,0 microns on a continuously steady-state basis. See 8.6 and Annex E.

3.14

terminal settling velocity

maximum velocity achieved by a particle under given conditions

3.15

test chamber

room size chamber for determining performance in removing particulate matter from the air

NOTE The specifications for the chamber are in Annex A.

3.16 Test particulate matter

3.16.1

cigarette smoke

produced by burning cigarette tobacco with air forced through the cigarette's filter having particle sizes detected from 0,10 µm to 1,0 µm diameter

3.16.2

air cleaner fine fraction test dust (Arizona road dust)

commercially available test dust with particle sizes detected from 0,5 µm to 3,0 µm

3.16.3

pollen

particulate matter naturally occurring from plants; pollen used is paper mulberry pollen (non-defatted) with a particle size range of 5 µm to 11 µm, including fragments

4 General conditions for measurement

4.1 Electrical supply

4.1.1 General

Standard frequencies and voltages for the CADR testing and operating power test are listed under 4.1.2 and 4.1.3. Other frequencies and voltages may be used to produce CADR values. The specific electrical supply conditions shall be concurrently reported with the applicable CADR values.

NOTE Refer to Clause 9 for the measurement of operating power test.

4.1.2 Frequencies

Operate air cleaner at one of the following frequencies:

Europe	50 Hertz
North America	60 Hertz
Japan	50/60 Hertz
China	50 Hertz
Australia and New Zealand	50 Hertz

4.1.3 Voltage

Operate air cleaner at one of the following voltages:

Europe	230V
North America	115V
Japan	100 V
China	220 V
Australia and New Zealand	230 V

NOTE See Clause 10 for the voltage requirements for the measurement of standby power test.

4.2 Test chamber ambient temperature

Chamber ambient temperature shall be $21\text{ °C} \pm 3\text{ °C}$ ($70\text{ °F} \pm 5\text{ °F}$) with a relative humidity (RH) of $40\% \pm 5\%$ for CADR and the measurement of operating power tests.

NOTE Refer to Clause 10 for the temperature for the measurement of standby power test.

4.3 Chamber air exchange rate

The chamber air exchange rate shall be less than 0,03 air changes per hour as determined by ASTM E747 or an equivalent method.

4.4 Chamber particulate concentrations

4.4.1 Measurability

The acceptable range of particle concentrations for the initial test condition (time (t) = 2 minutes for cigarette smoke; $t = 0$ minutes for dust and pollen) are:

Cigarette smoke	24 000 particles/cm ³ to 35 000 particles/cm ³ (diluter may be required)
Sampling period	(20 s at 0,06 L/min \pm 5 %)
Dust	200 particles/cm ³ to 400 particles/cm ³
Sampling period	(20 s at 1 L/min \pm 5 %)
Pollen	4 particles/cm ³ to 9 particles/cm ³
Sampling period	(20 s at 1 L/min \pm 5 %)

NOTE Use of a particle counter with different flow rates than the ones specified above is acceptable as long as the particle counter provides equivalent performance characteristics.

The lower limit of instrument measurability is based on a minimum of 10 particle counts and is defined by the practical counting limits of particle measuring instrumentation. These are:

Dust	0,03 particles/cm ³
Cigarette smoke	20 particles/cm ³
Pollen	0,03 particles/cm ³

4.4.2 Test chamber background level

This is the allowable level of particulate matter in the test chamber prior to the introduction of the test material. This level is not to be greater than the lower limit of instrument measurability.

NOTE If the instrument's measurability lower limit cannot readily be achieved, further chamber cleaning procedures should be performed.

4.5 Chamber equipment

The recirculation fan shall be operated throughout all tests in Clause 5, Clause 6, and Clause 7. See Annex A for proper positioning of the recirculation fan.

4.6 Test equipment preparation

4.6.1 General

Check contaminant generating, measuring and recording instruments, and data processing equipment for readiness as specified in the manufacturer's instructions (see Annex C).

4.6.2 Test unit set-up

Test unit is installed in accordance with the manufacturer's instructions, placing the unit (or test fixture containing the unit) in the center of the room, positioned with its air discharge as close as possible to the room center. For test units which discharge air in a specific direction, the air discharge shall not be pointed toward the particle monitors. If manufacturer's instructions do not specify (and unit is not a floor model), place the air cleaner on the table for test. See 3.11 for positioning of specify types of room air cleaners in the chamber.

Room air cleaners with multi-level performance fan settings are typically adjusted to the highest air cleaning mode setting for test. Other performance settings shall be concurrently reported with the applicable CADR values (see Annex C).

5 Test procedure for determining performance on cigarette smoke

5.1 General

To determine the performance on cigarette smoke, perform the test procedures prescribed in 5.2 and 5.3 sequentially during the same day (see C.3.a)). An appropriate cigarette smoke sample diluter (see Annex A) shall be used with the cigarette smoke monitor.

5.2 Natural decay measurement

- a) Place the air cleaner to be tested in the chamber in accordance with 4.6.2 and set the air cleaner controls to the conditions for test. Test for proper operation, then shut off with switch external to test chamber.
- b) Operate the ceiling mixing fan and create a log file for the run.
- c) Using the chamber HEPA filter, allow the test chamber air to clean until the background particulate matter for particles in the size range of 0,1 μm to 1,0 μm reaches a level of less than 20 particles/cm³. Simultaneously operate the environmental control devices until the room conditions (temperature and RH) are as specified in 4.2.
- d) Procedure
 - 1) When an acceptable test chamber background level is achieved (as indicated in 5.2 c)) record the background concentration, turn off the chamber environmental control system (humidifiers, HEPA filter, blowers, supply dampers and return dampers).
 - 2) Immediately light, then place one standard cigarette in the cigarette smoke generator, seal generator, open valve to chamber, and turn on 4-6 scfh air supply to the cigarette generator to provide the required initial concentration (24 000 to 35 000 particles/cm³ as noted in 4.4.1).

NOTE It should take approximately 45 s to reach the required initial concentration.

- 3) Turn off air supply and close chamber valve.

- 4) Mix cigarette smoke for one minute after the initial concentration has been reached, then turn off ceiling mixing fan. The recirculation fan will continue to operate for the duration of the test.
- e) Three minutes after turning off ceiling mixing fan, begin to acquire the cigarette smoke particulate concentration. This test point is the initial chamber concentration ($t = 0$ min). If the cigarette smoke concentration is not within the initial limits (refer to 4.4.1), terminate the run.
- f) Acquire particle concentration data at one-minute intervals for 20 min. A minimum of nine data points having particle concentrations greater than the lower limit of instrument measurability are required.
- g) Record the average RH and temperature of the chamber during the test period. Values outside the limits in 4.2 and 4.3 invalidate the run.
- h) Calculate the decay constant for cigarette smoke as specified in 8.2.
- i) Determine the acceptability of the run by calculating the standard deviation of the natural decay in accordance with 8.3. A standard deviation of less than the 95 % confidence limit of $0,002 \text{ min}^{-1}$ or 10 %, whichever is greater, determines the acceptability of the run.

5.3 Cigarette smoke particulate matter removal measurement with air cleaner operating (includes natural decay)

- a) Operate the ceiling mixing fan and create a log file for the run.
- b) Using the chamber HEPA filter, allow the test chamber air to clean until the background particulate matter or particles in size range of $0,1 \mu\text{m}$ to $1,0 \mu\text{m}$ reaches a level of less than $20 \text{ particles/cm}^3$ and simultaneously operate the environmental control devices until the room conditions (temperature and RH) are as specified in 4.2.
- c) Procedure
 - i) When an acceptable test chamber background level is achieved (as indicated in 5.2 b), record the background concentration, turn off the chamber environmental control system (humidifiers, HEPA filter, blowers, supply dampers and return dampers).
 - ii) Immediately light, then place one standard cigarette in the cigarette smoke generator, seal generator, open valve to chamber, and turn on 4 to 6 scfh (about 45 s) air supply to the cigarette generator to provide the required concentration (as noted in 4.4.1).
 - iii) Turn off air supply and close chamber valve.
 - iv) Mix cigarette smoke for 1 min, then turn off ceiling mixing fan. The recirculation fan will continue to operate for the duration of the test. Wait 1 min for fan to stop. Turn on air cleaner. The time at which the air cleaner is turned on is defined as time (t) = 0 min.
- d) Two minutes after turning on the air cleaner, begin to acquire the cigarette smoke particulate concentration. This test point is the initial chamber concentration. If the cigarette smoke concentration is not within the initial limits (refer to 4.4.1), terminate the run.
- e) Acquire particle concentration data at 1 min intervals for 20 min, beginning at the two minute point ($t = 2$ min). Use all acceptable data points. Refer to 8.1 for elimination of data points to determine acceptability. A minimum of nine acceptable data points are required.

NOTE The operating power test described in Clause 9 can be conducted during this particle concentration data acquisition phase if desired.

- f) Turn off the air cleaner. Record the average RH and temperature of the chamber during the test period. Values outside the limits in 4.2 and 4.3 invalidate the run.
- g) Calculate the decay constant for cigarette smoke as specified in 8.2.
- h) Determine the acceptability of the run by calculating the standard deviation of the particulate matter removal in accordance with 8.3. A standard deviation of less than

the 95 % confidence limit of $0,008 \text{ min}^{-1}$ or 10 %, whichever is greater, determines the acceptability of the run.

- i) Determine the CADR of the air cleaner in accordance with 8.4.
- j) Determine the acceptability of the test by calculating an estimate of the standard deviation for a single test CADR according to 8.5. A two standard deviation estimate of less than CADR of 9 cfm or 10 %, whichever is greater, determine an acceptable test.

6 Test procedure for determining performance on test dust

6.1 General

To determine the performance on test dust, perform the test procedures prescribed in 6.2 and 6.3 sequentially during the same day (see C.3.b))

6.2 Natural decay measurement

- a) Place the air cleaner to be tested in the chamber in accordance with 4.6.2 and set the air cleaner controls to the conditions for test. Test for proper operation, then shut off with switch external to test chamber.
- b) Operate the ceiling mixing fan and create a log file for the run.
- c) Using the chamber HEPA filter, allow the test chamber air to clean until the background particulate matter for particles in the size range of $0,5 \mu\text{m}$ to $3,0 \mu\text{m}$ reaches a level of less than $0,03 \text{ particle/cm}^3$. Simultaneously operate environmental control devices until the room conditions (temperature and RH) are as specified in 4.2.
- d) Procedure
 - 1) When an acceptable test chamber background level is achieved (as indicated in 6.2 c) record the background concentration. Turn off the chamber environmental control system (humidifiers, HEPA filter, blowers, supply dampers and return dampers.)
 - 2) Immediately turn on the air supply to the aerosol generator and then the aerosol generator. Continue to generate test dust until the particle concentration in the chamber reaches the required initial concentration ($200 \text{ particles/cm}^3$ to $400 \text{ particles/cm}^3$ as noted in 4.4.1).
 - 3) When the concentration is within initial test limits, turn off the aerosol generator air supply and aerosol generator.

CAUTION A radioactive source is utilized by the dust generator for charge neutralization.

- 4) Mix dust for 1 min after the initial concentration has been reached, then turn off ceiling mixing fan. Wait one minute for the fan to stop. The recirculation fan will continue to operate for the duration of the test.
- e) Begin to acquire the particle concentration with the dust monitor. This test point is the initial chamber concentration ($t=0 \text{ min}$). If the test dust concentration is not within initial limits, terminate the run.
- f) Acquire particle concentration data at one-minute intervals for 20 min. A minimum of nine data points having particle concentrations greater than the lower limit of instrument measurability are required.
- g) Record the average RH and temperature of the chamber during the test period.
- h) Calculate the decay constant for test dust as specified in 8.2.
- i) Determine the acceptability of the run by calculating the standard deviation of the natural decay in accordance with 8.3. A standard deviation of less than the 95 % confidence limit of $0,001 \text{ min}^{-1}$ or 10 %, whichever is greater, determines the acceptability of the run.

6.3 Dust particulate matter removal measurement with air cleaner operating (includes natural decay)

- a) Operate the ceiling mixing fan and create a log file for the run.
- b) Using the chamber HEPA filter, allow the test chamber air to clean until the background particulate matter for particles is in the size range of 0,5 μm to 3,0 μm reaches a level of less than 0,03 particle/cm³. Simultaneously operate the environmental control devices until the room conditions (temperature and RH) are as specified in 4.2.
- c) Procedure
 - 5) When an acceptable test chamber background level is achieved (as indicated in 6.2 c), record the background concentration, turn off the chamber environmental control system (humidifiers, HEPA filter, blowers, supply dampers and return dampers).
 - 6) Immediately turn on the air supply to the aerosol generator and then the aerosol generator. Continue to generate test dust until the particle concentration in the chamber reaches the required initial concentration (200 particles/cm³ to 400 particles/cm³ as noted in 4.4.1).
 - 7) When the concentration is within initial test limits, turn off the aerosol generator air supply and aerosol generator.

CAUTION A radioactive source is utilized by the dust generator for neutralization.

- 8) Mix dust for one minute, then turn off ceiling mixing fan. Wait one minute for fan to stop. Turn on air cleaner. This is $t=0$ min.
- d) Begin to acquire the particle concentration with the dust monitor at $t = 0$ min. This test point is the initial chamber concentration. If the test dust concentration is not within the initial limits, terminate the run.
- e) Acquire particle concentration data at one-minute intervals for 20 min, beginning at $t = 0$ min. Use all acceptable data points. Refer to 8.1 to determine acceptability. A minimum of nine acceptable data points are required.

NOTE The operating power test described in Clause 9 may be conducted during this particle concentration data acquisition phase if desired.
- f) Turn off the air cleaner. Record the average RH and temperature of the chamber during the test period. Values outside the limits in 4.2 and 4.3 invalidate the run.
- g) Calculate the decay constant for test dust as specified in 8.2.
- h) Determine the acceptability of the run by calculating the standard deviation of the particulate matter removal in accordance with 8.3. A standard deviation of less than the 95 % confidence limit of 0,003 min⁻¹ or 10 %, whichever is greater, determines the acceptability of the run.
- i) Determine the CADR of the air cleaner in accordance with 8.4.
- j) Determine the acceptability of the test by calculating an estimate of the standard deviation for a single test CADR according to 8.5. A two standard deviation estimate of less than a CADR of 10 cfm or 10 %, whichever is greater, determines an acceptable test.

7 Test procedure for determining performance on paper mulberry pollen

7.1 General

To determine the performance on paper mulberry pollen, perform the test procedures prescribed in 7.2 and 7.3 sequentially during the same day (see C.3.c)).

7.2 Natural decay measurement

- a) Place the air cleaner to be tested in the center of the chamber in accordance with 4.6.2 and set the air cleaner controls to the conditions for test. Test for proper operation, then shut off and switch external to test chamber.
- b) Operate the ceiling mixing fan and create a log file for the run.
- c) Using the chamber HEPA filter, allow the test chamber air to clean until the background particulate matter for particles in the size range of 5 µm to 11 µm reaches a level of less than 0,03 particle/cm³. Simultaneously operate the environmental control devices until the room conditions (temperature and RH) are as specified in 4.2.
- d) Procedure
 - 1) When an acceptable test chamber background level is achieved (as indicated in 7.2 c), record the background concentration, turn off the chamber environmental control system (humidifiers, HEPA filter, blowers, supply dampers and return dampers.)
 - 2) Attach one of the pre-weighed paper mulberry pollen sample bottles to the pollen generator (see C.3.c)).
 - 3) Open the chamber valve to the pollen generator and turn on the pollen generator air supply at 1,4 kg/cm² (20 psig) for 10 s. Turn off the air supply and close the chamber valve.
 - 4) Mix pollen for one minute after the initial concentration has been reached, then turn off ceiling mixing fan. Wait one minute for the fan to stop. The recirculation fan will continue operation for the duration of the test.
- e) Begin to acquire the particle concentration with the dust monitor. This test point is the initial chamber concentration ($t = 0$ min). If the pollen concentration is not within the initial limits (4 particles/cm³ to 9 particles/cm³ as noted in 4.4.1), terminate the run.
- f) Acquire particle concentration data at one-minute intervals for 10 min. A minimum of five points having particle concentrations greater than the lower limit of instrument measurability are required.

NOTE The minimum of five points required for pollen is less than the minimum of nine points required for tobacco smoke and dust due to pollen's faster decay rate and due to the shorter data acquisition period specified for pollen.

- g) Record the average RH and temperature of the chamber during the test period.
- h) Calculate the decay constant for pollen as specified in 8.2.
- i) Determine the acceptability of the run by calculating the standard deviation of the natural decay in accordance with 8.3. A standard deviation of less than the 95 % confidence limit of 0,009 min⁻¹ or 10 %, whichever is greater, determines the acceptability of the run.

7.3 Pollen particulate matter removal measurement with air cleaner operating (includes natural decay)

- a) Operate the ceiling mixing fan and create a log file for the run.
- b) Using the chamber HEPA filter allow the test chamber air to clean until the background particulate matter for particles in the size range of 5 µm to 11 µm reaches a level of less than 0,03 particle/cm³. Simultaneously operate the environmental control devices until the room conditions (temperature and RH) are as specified.
- c) Procedure
 - 1) When an acceptable test chamber background level is achieved (as indicated in 7.3 b) record the background concentration, turn off the chamber environmental control system (humidifiers, HEPA filter, blowers, supply dampers and return dampers).
 - 2) Attach one of the pre-weighed paper mulberry pollen sample bottles to the pollen generator (see C.3.c)).

- 3) Open the chamber valve to the pollen generator and turn on the pollen generator air supply at $1,4 \text{ kg/cm}^2$ (20 psig) for 10 s. Turn off the air supply and close the chamber valve.
- 4) Mix pollen for 1 min, then turn off the ceiling mixing fan. Wait 1 min for fan to stop. Turn on air cleaner. This is $t = 0$ min.
- d) Begin to acquire the particle concentration with the dust monitor at $t = 0$ min. This test point is the initial chamber concentration. If the test pollen concentration is not within the initial limits, terminate the run.
- e) Acquire particle concentration data at one-minute intervals for 10 min, beginning at $t = 0$ min. Use all acceptable data points. Refer to 8.1 to determine acceptability. A minimum of five acceptable data points are required.

NOTE The minimum of five points required for pollen is less than the minimum of nine points required for tobacco smoke and dust due to pollen's faster decay rate and due to the shorter data acquisition period specified for pollen.

- f) Turn off the air cleaner. Record the average RH and temperature of the chamber during the test period. Values outside the limits in 4.2 and 4.3 invalidate the run.
- g) Calculate the decay constant for pollen as specified in 8.2.
- h) Determine the acceptability of the run by calculating the standard deviation of the particulate matter removal in accordance with 8.3. A standard deviation of less than the 95 % confidence limit of $0,022 \text{ min}^{-1}$ or 10 %, whichever is greater, determine an acceptable run.
- i) Determine the CADR of the air cleaner in accordance with 8.4.
- j) Determine the acceptability of the test by calculating the standard deviation for a single test CADR according to 8.5. A two standard deviation estimate of less than CADR = 23 cfm or 20 %, whichever is greater, determines an acceptable test.

8 Calculation procedures (see Annex D)

8.1 Criteria for elimination of data points from a run

There are four criteria for eliminating a data point from a run. The first is operator error. The second is equipment error either in the sensing, recording, or reporting of information. The third is the data point is not within the 95 % prediction limit of the regression line. The fourth is decay below the minimum acceptable concentration limits of the instrument.

- **Criterion 1.** Any noted operator error results in the elimination of the data point whether or not the data point (corresponding to the time the error is noted) is found within acceptable or anticipated concentration ranges.
- **Criterion 2.** Any noted equipment error will result in the elimination of the data point (corresponding to the time the error is noted) whether or not the data point is found within acceptable or anticipated concentration ranges.
- **Criterion 3.** Any data points found to be outside the 95 % prediction limits of the regression slope line will result in the elimination of the data point. The cause of the outlier data may or may not be due to chamber instrumentation, air cleaner inconsistency, or other chamber effects.
- **Criterion 4.** Any data point resulting in a reported concentration below the instrument measurability limit will be eliminated along with all subsequent data points in the run. Subsequent data points are eliminated based on the anticipated theoretical reduction of concentration with time. Any data point taken after one rejected for Criterion 4 would be theoretically expected to also be eliminated by Criterion 4.

8.2 Calculating the decay constant

Since the chamber air exchange is negligible (maximum contribution to slope of $0,00051 \text{ min}^{-1}$) the air exchange rate is not included in the calculations.

8.2.1 The decay constant, k , for particulate matter is based on the formula:

$$C_{ti} = C_i e^{-kt_i} \quad (1)$$

where

C_{ti} is the concentration at time t_i , expressed in particles/cm³;

C_i is the concentration at $t = 0$ min;

k is the decay rate constant, expressed in minutes⁻¹;

t_i is time, expressed in minutes.

8.2.2 The decay constant, k , is obtained using the linear regression on the $\ln C_{ti}$ and t_i using the formula:

$$K = \frac{S_{XY}}{S_{XX}} \quad (2)$$

where

$$S_{xy} = \sum_{i=1}^N t_i \ln C_{ti} - (1/n) \left(\sum_{i=1}^n t_i \right) \left(\sum_{i=1}^n \ln C_{ti} \right) \quad (3)$$

$$S_{xx} = \sum_{i=1}^N (t_i)^2 - (1/n) \left(\sum_{i=1}^n t_i \right)^2 \quad (4)$$

When the above calculations are used for natural decay measurements in 5.2, 6.2 and 7.2, the results represent the natural decay rate in the room air. When the above calculations are used for the total particulate matter removal measurements in 5.3, 6.3, and 7.3, the results represent the air cleaner particulate matter removal rate, which also includes natural decay of the particles.

8.3 Computation of the standard deviation estimate for the slope of one regression line

8.3.1 Step 1: Calculation of standard deviation of a regression line

An estimate of the standard deviation about the regression line is calculated as follows:

$$S_{\text{reg}} = \sqrt{\left[\frac{1}{(n-2)} \sum_{i=1}^n (\ln C_{ti} - b - mt_i)^2 \right]} \quad (5)$$

where

S_{reg} is the estimated value of the overall standard deviation;

n is the number of pairs of data points used in the regression;

b is the intercept of the regression line (equivalent to an estimated initial concentration) expressed as \ln (particles/cm³);

m is the slope of the regression line, expressed as min⁻¹;

t_i is the time at the data point, expressed in minutes;

$\ln C_{ti}$ is the natural logarithm of the concentration at time, t_i .

8.3.2 Step 2: Calculation of standard deviation estimate of the regression line slope

The standard deviation estimate of the slope of the regression line is calculated as follows:

$$S_{\text{slope}} = \sqrt{\frac{S_{\text{reg}}^2}{S_{xx}}} \quad (6)$$

8.4 Performance calculation

The performance of a portable household room air cleaner is represented by a clean air delivery rate (CADR). A method for calculating the clean air delivery rate is:

$$\text{CADR} = V(k_e - k_n) \quad (7)$$

where

CADR is the clean air delivery rate, expressed in cubic feet per minute;

V is the volume of test chamber, expressed in cubic feet;

k_e is the total decay rate, expressed in min^{-1} ;

k_n is the natural decay rate, expressed in min^{-1} .

8.5 Calculation of the standard deviation estimate of the CADR for a single test

The standard deviation estimate as described above for each of the natural and total decay lines can be combined using error propagation analysis on the equation used to compute the CADR in 8.4.

The chamber volume is taken as a constant and the following equation is used to estimate the standard deviation for the CADR computed for the pair of regression lines.

$$S_{\text{CADR}} = 1\,008 \sqrt{[S(\text{slope}, k_e)^2 + S(\text{slope}, k_n)^2]} \quad (8)$$

where

S_{CADR} is the estimated standard deviation for CADR, expressed in $\text{cu ft}/\text{min}$;

$S(\text{slope}, k_e)$ is the estimated standard deviation of the total decay rate, expressed in min^{-1} ;

$S(\text{slope}, k_n)$ is the estimated standard deviation of the natural decay rate, expressed in min^{-1} ;

1 008 is the volume of the test chamber, in ft^3 , treated as a constant, which is used to put the estimated standard deviation value in CADR units.

8.6 Calculation of suggested room size

The suggested room size for an air cleaner is based upon the CADR obtained for cigarette smoke as determined in Clause 5. The room size is based upon the ability of the air cleaner's CADR to reduce the concentration of particles in a room at steady-state to a new steady-state concentration 80 % less than the original when the air cleaner is operating. The theoretical assumptions of the room characteristics are based upon a mixing factor equal to 1,0, an air exchange rate of $1,0 \text{ h}^{-1}$, a cigarette smoke particle natural decay equal to the average background natural decay rate (from statistical study), a ceiling height of 2,4 m (8 ft), and a cigarette smoke particle generation or influx rate such that a cigarette smoke particle concentration of unity (1) is maintained at the initial steady-state. A standard first-order differential equation is utilized for the calculation that is derived in Annex E and summarized as:

$$\text{Room size (square feet)} = \text{cigarette smoke CADR} \times 1,55$$

$$\text{Room size (square meters)} = \text{room size (square feet)} \times 0,093$$

where

CADR is the Clean Air Delivery Rate determined from Equation 7.

9 Measurement of operating power¹

9.1 Conditions of measurement

The measurement described in this clause shall be conducted in accordance with the conditions described in Clause 4. For equipment (and its accuracy specification), see to Annex A.

NOTE This measurement may be conducted simultaneously with the tobacco smoke or dust particle matter removal tests noted in either 5.3 e) and 6.3 e), as both of these tests are of sufficient length.

9.2 Conditioning of room air cleaner prior to measurement

Prior to measuring operating power, the air cleaner's motor shall be properly broken in by running the unit, without filters, for 48 h.

9.3 Measurement procedure

9.3.1 After the unit motor has been properly conditioned, in accordance with the equipment manufacturer's instructions, connect the power measuring instrument between the power supply and the air cleaner unit under test.

9.3.2 Turn the air cleaner on with all settings/options set at maximum level and reset the power measuring instrument.

9.3.3 Adjust the power supply indicator to appropriate voltage and frequency (see 4.1.2 and 4.1.3).

9.3.4 Allow the air cleaner to run for 2 min without taking any Watt readings. After this 2 min initial runtime, begin recording Watt readings at 1 min intervals for 13 min. The entire test should take 15 min total.

9.4 Operating power results

To obtain the operating power of the unit in Watts, average the data points. Up to 3 of the 13 readings may be thrown out as anomalous to address potential line surges and other variables.

10 Measurement of standby power²

10.1 Conditions of measurement

10.1.1 Air Speed. The tests shall be carried out in a room that has an air speed close to the air cleaner under test of $\leq 0,5$ m/s.

10.1.2 Ambient Temperature. The ambient temperature shall be maintained at $23\text{ °C} \pm 5\text{ °C}$ throughout the test.

10.1.3 Voltage. Voltage supply shall be as specified in 4.1.3.

For equipment (and its accuracy specification), see Annex A.

NOTE The measured power for some products and modes may be affected by the ambient conditions (e.g. illuminance, temperature).

¹ In accordance with the U.S. Environmental Protection Agency (EPA) Air Cleaner Energy Star Requirements Eligibility Criteria – Energy Consumption Test Protocol.

² In accordance with the U.S. Environmental Protection Agency (EPA) Air Cleaner Energy Star Requirements Eligibility Criteria – Test Procedure for Measuring Standby Power.

10.2 Preparation of room air cleaner model for testing

Tests are to be performed on a single room air cleaner model. The room air cleaner model shall be prepared and set up in accordance with the manufacturer's instructions, except where these conflict with the requirements of this test procedure. If no instructions are given, then factory or "default" settings shall be used, or where there are no indications for such settings, the air cleaner model is tested as supplied.

For portable air cleaners having a rechargeable battery, standby mode is measured on the charger or docking/base station with the air cleaner detached from its regular source of power in the "on" position.

10.3 Test procedure

10.3.1 This test procedure may only be used where the selected mode and measured power are stable. A variation of less than 5 % in the measured power over 5 min is considered stable for the purposes of testing for standby power usage under this specification. Instrument power readings may be used in this case.

10.3.2 Connect the air cleaner model to be tested to the metering equipment in the stable mode.

10.3.3 After the air cleaner model has been allowed to stabilize for at least 5 min, monitor the operating power for not less than an additional 5 min.

10.3.4 If the power level does not drift by more than 5 % (from the maximum value observed) during the latter 5 min, the load can be considered stable and the power can be recorded directly from the instrument at the end of the 5 min.

10.4 Test results

Standby power shall be reported as the average power in Watts rounded to the second decimal place.

11 Reporting

The template test data sheets shown in Annex F identify the parameters that shall be recorded during CADR testing and reported for each test.

12 Safety

It is recommended that household room air cleaners meet the relevant safety requirements of Underwriters Laboratories Inc., such as UL 867, Standard for Electrostatic Air Cleaners, latest edition³, and UL 507, Standard for Fans, latest edition.

³ Copies of UL Standards are available through COMM 2000, 1414 Brook Drive, Downers Grove, IL 60515, 1-888-UL33503, www.comm-2000.com, E-mail: sales@comm-2000.com.

Annex A (normative)

Details of test chamber construction and equipment

A.1 Test chamber construction (equivalent material and equipment substitutes are acceptable)

No silicone caulk shall be used in the test chamber.

Chamber size	Inside dimensions, 3,2 m × 3,7 m × 2,4 m, 28,5 m ³ (10 ½ ft × 12 ft × 8 ft, 1 008 ft ³)
Framework	Standard 5,1 cm × 10,2 cm (2 in × 4 in) construction, sealed at floor line, inside and outside with caulking compound
Walls	1,3 cm (½ in) wallboard over 0,9 cm (3/8 in) plywood
Flooring	Seamless, smooth surface, full width linoleum or vinyl
Filtration	High efficiency particulate air (HEPA) filter 99,97 % efficient for 0,3 µm DOP cigarette smoke (1 000 cfm). Pre-filter 60 % ASHRAE efficiency roughing filter 20 % to 30 % ASHRAE efficiency.
Paint	White, washable latex semi-gloss
Ceiling fan	3 blade, 0,91 m (36 in), ceiling fan 395 RPM Stock No. 4C852 Amps 0,5, Volts 120, Weight 12,7 kg (28 lbs) or equivalent. Available from W.W. Grainger.
Motor and blower for reconditioning loop	21,5 m ³ /m (750 cfm) fan, 10,2 cm (4 in) WG, 3/4 HP motor, 208 Volts, 3 phase
Recirculation fan Position	The recirculation fan is positioned 1,5 m (60 in) from the floor to the center of the motor and 0,4 m (15 in) from the back wall to the fan unit.
Table stand	Height: 0,74 m (29,25 in) from the floor Table top size: 0,36 m × 0,56 m × 0,03 m (14 in × 22 in × 1 in)

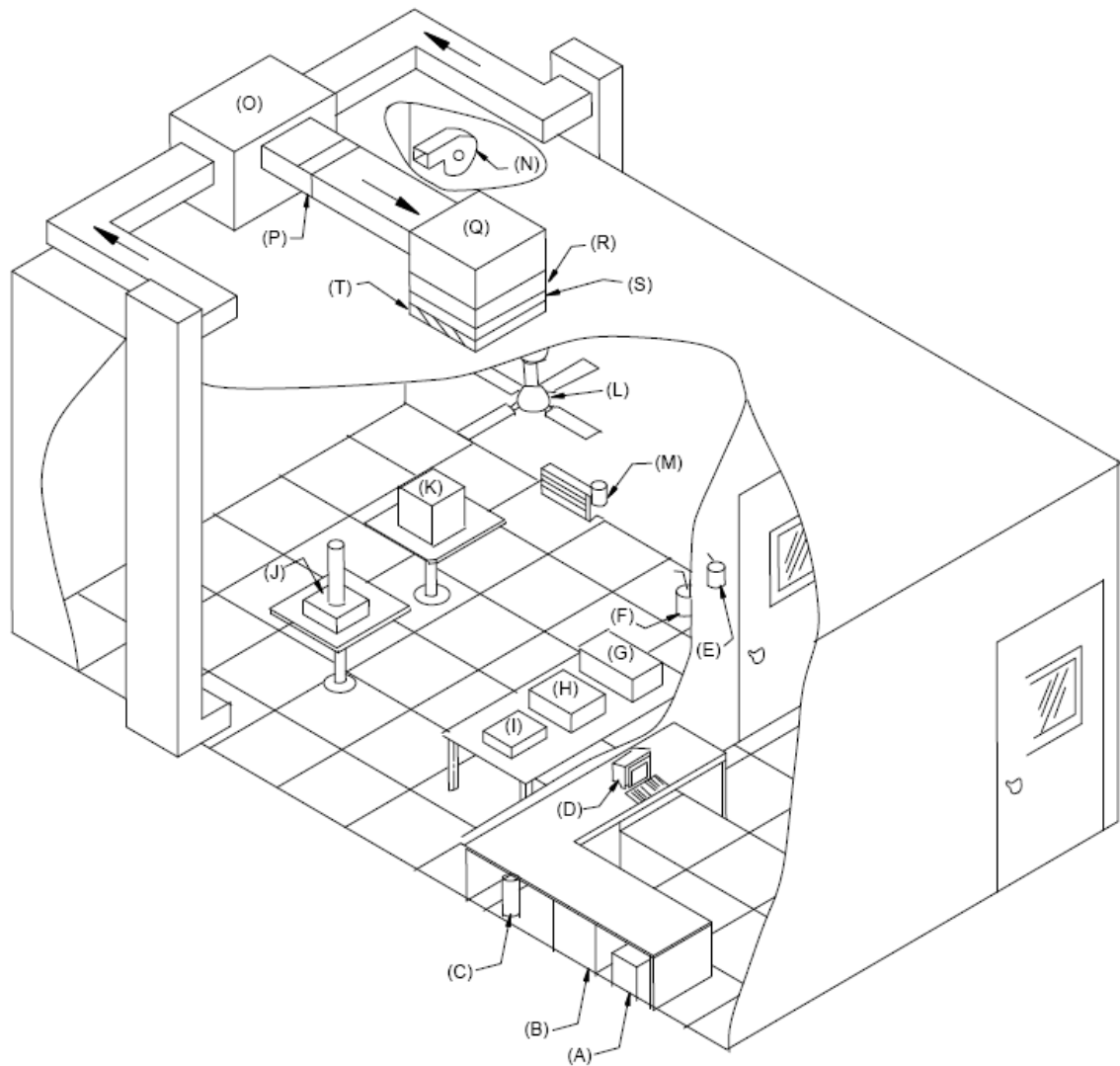

KEY

A	Voltage regulator	K	Test unit
B	Data acquisition and control interface	L	Ceiling mixing fan
C	Air supply (filter/drier)	M	Return air damper (2)
D	Computer terminal	N	Recirculation fan
E	Cigarette smoke pot	O	Humidifier
F	Pollen generator	P	Prefilter
G	Dust and pollen monitor	Q	Blower section
H	Smoke monitor	R	HEPA filter
I	Cigarette smoke diluter	S	Electric heater
J	Dust generator	T	Supply air damper

Figure A.1 – Air cleaner chamber

A.2 Test chamber equipment (equivalent substitutes are acceptable)⁴

A.2.1 Recirculation fan

Available from:

W.W. Grainger, Inc.

6285 E. Molloy Rd.

Syracuse NY 13057

Phone: (800) 323 0620

Web site: www.grainger.com

Model No. 4C448

Shaded Pole Blower

A.2.2 Relative humidity – Temperature sensor

Available from:

Vaisala, Inc.

100 Commerce Way

Woburn, MA 01801

Phone: (781) 933 4500

Web site: www.vaisala.com

Model HMW 3OYB

A.2.3 Temperature – Relative humidity reconditioning loop equipment

Humidifier

Available from:

D.F. Brandt, Inc.

8152 Kirkville Road

Kirkville, N.Y. 13082

Web site: www.dfbrandt.com

Model RESDELUX

Steam Humidifier

A.2.4 Cooling/dehumidifying equipment

Available from:

Trane Co.

LaCrosse, WI 54601

Web site: www.trane.com

Model No. XE900 1 ton condensing unit

Model EAS Evaporator Coil

⁴ This information is given for the convenience of the users of this PAS and does not constitute an endorsement by the IEC.

A.2.5 Reheater

Available from:

INDEECO

425 Hanley Industrial Court

St. Louis MO 63144

Web site: www.indeeco.com

10 kW duct heater

A.2.6 Voltage regulator

Available from:

Newark Electronics

4801 N. Ravenswood Ave.

Chicago, IL 60640

Phone: (312) 784 5100

Web site: www.newark.com

Sola Type 63-23-220-8 2 kVA 60 Hz

Single phase minicomputer regulator

A.2.7 Watt transducer

Available from:

Ohio Semitronics Inc.

4242 Reynolds Drive

Hilliard, OH 43026

Phone: (800) 537 6732

Web site: www.ohiosemi.com

Model AGH-002B 300V, 5A watt transducer

A.2.8 Particulate matter generation and measurement

Dust Generator

Available from:

TSI Inc

500 Cardigan Rd.

Shoreview, MN 55126

Phone: (800) 874 2811

Web site: www.tsi.com

Model 3400 Fluidized Bed Aerosol Generator

A.2.9 Dust neutralizer

Available from:

TSI Inc.

500 Cardigan Rd.

Shoreview, MN 55126

Phone: (800) 874 2811

Web site: www.tsi.com

Model 3012 Aerosol Neutralizer

A.2.10 Dust/pollen particle counter

Available from:

TSI Inc.

500 Cardigan Rd.

Shoreview, MN 55126

Phone: (800) 874 2811

Web site: www.tsi.com

Aerodynamic Particle Sizer® (APS) Spectrometer - Model 3321

A.2.11 Cigarette smoke monitor

Available from:

Particle Measuring Systems, Inc.

5475 Airport Blvd.

Boulder CO 80301

Phone: (800) 238 1801

Web site: www.particlemeasuringsystems.com

High Sensitivity Laser Aerosol Spectrometer Probe

PMS Model HS-LAS 32 Ch 0.0654-1.00

A.2.12 Pollen generator

2 oz screw-top glass laboratory sample jars sealed air tight with nominal 1/4 in brass fittings for air entry, and pollen discharge.

Air Supply

Available from:

TSI Inc.

500 Cardigan Rd.

Shoreview, MN 55126

Phone: (800) 874 2811

Web site: www.tsi.com

Model 3074 - Air Supply System

A.2.13 Isokinetic diluter

Available from:

Stainless Design Concepts

1117 Kings Hwy

Saugerties, NY 12477

Phone: (845) 246 3631

Web site: www.stainlessdesign.com

Custom Aerosol diluter - six to one dilution ratio
at 1 cm³/s total flow rate.

**A.2.14 Operating power and standby power measurement watt meter
(or equivalent instrument)**

Watt Meter or equivalent instrument capable of measuring true RMS watts

Accuracy: $\pm 1\%$ at 120 V, 60 Hz

Resolution: 0,01 W (or better)

Annex B (normative)

Sources of test materials (equivalent substitutes are acceptable)⁵

a) Air cleaner test dust:

Powder Technology Inc. (PTI Inc.)
14331 Ewing Avenue South
Burnsville, MN 55306
Phone: (952) 894 8737
Web site: www.powdertechologyinc.com
Fine Air Cleaner Test Dust

b) Cigarettes:

Kentucky Tobacco Research and Development Center (KTRDC)
University of Kentucky
Lexington KY 40506
Phone: (859) 257 1657
Web site: www.uky.edu/KTRDC

2R4F Research Cigarettes

c) Paper mulberry pollen (non-defatted):

Greer Laboratories Inc.
Box 800
Lenoir, NC 28645
Phone: (800) 378 3906
Web site: www.greerlabs.com

⁵ This information is given for the convenience of the users of this PAS and does not constitute an endorsement by the IEC.

Annex C (informative)

Standard laboratory operation procedures when testing portable room air cleaners

C.1 Receipt of test units

Units received for testing should be inspected upon receipt for shipping damage or other obvious visual defects. The supplier of the units should be notified immediately of defects or damage and provide a disposition.

Units should be logged in and forwarded to the test facility run-in room.

C.2 Test room preparation

Perform startup and cleaning procedures in accordance with C.4 and C.6.

C.3 Contaminant preparation

a) Cigarette smoke:

Store an adequate number of cigarettes from a single pack at room temperature and a relative humidity of 70 % ± 15 % for 24 h to 72 h prior to a test series.

The cigarette smoke generator, including injection tube, should be cleaned weekly.

For long term storage (i.e. more than 30 days) of test standard cigarettes (Annex B), keep at a temperature of 4 °C ± 2 °C (39 °F ± 3,6 °F) and relative humidity of 50 % ± 10 %.

b) Air cleaner test dust:

- 1) Special preparations of contaminant are not necessary.
- 2) Set pressure for dispersing dust at 2,8 kg/cm² to 4,2 kg/cm² (40 psig to 60 psig) and check dryer desiccant.
- 3) For storage of the test dust specified in 3.16.2, store in a desiccating chamber with a maximum RH of 20 %.

c) Paper mulberry pollen:

- 1) 1,2 g of uniformly mixed pollen is divided into 4 approximately equal sections using a razor blade or small fine edged micro-spatula. Pollen shall be divided in an area having no more than 40 % RH.
- 2) Load each 1/4 of the pollen into separate generator jars.
- 3) Store loaded generator jars in desiccators with drying agent for a minimum of 24 h prior to testing.
- 4) When ready to test, adjust air pressure of the pollen generator to 1,4 kg/cm² (20 psig).
- 5) For long term storage of the pollen specified in 3.16.3, store in a desiccating chamber with a maximum RH of 20 %.

C.4 Start-up procedures

NOTE These procedures are specific to the equipment listed in Annex A.

- a) Turn on main power to computer and reconditioning system.

- b) Start reconditioning loop and turn on recirculation fan to get room ambient conditions.
- c) Prior to dust or pollen tests, turn on APS 3321 as follows:
 - Power switch on, wait 10 s.
 - Pump switch on, wait 10 s.
 - Laser switch on.
 - Let the instrument warm up sufficiently.
- d) Prior to cigarette smoke tests, turn on HS-LAS as follows:
 - Power switch on, wait 10 s.
 - Adjust sample flow (1 cm³/s); sheath flow (20 cm³/s).
 - Wait a minimum of 30 s.
 - Check laser reference voltage (shall be above 4,5 V). If low, adjust as specified by manufacturer's instructions.
 - Let the instrument warm up sufficiently.
- e) Clean test room, according to procedures in C.6.
- f) When test room conditions are safely within requirements, start test runs.

C.5 Shutdown procedures

- a) Turn on reconditioning loop to remove residual particulates.
- b) Power down APS 3321 in this order:
 - Laser switch;
 - Pump switch;
 - Power switch.
- c) Power down HS-LAS by turning off power switch.
- d) Turn off recirculation fan.
- e) Perform full daily cleaning procedures (C.6 and C.7).
- f) Turn off main power switch.

C.6 Daily start-up cleaning procedures

NOTE These procedures were written for a specific facility and should be regarded as typical. They have been found to be sufficient to achieve required test chamber background concentrations.

- a) Wash cigarette smoke generator and used pollen jars.
- b) Use damp lint-free wipe to clean inside lids of cigarette smoke generator and pollen generator.
- c) Damp sponge countertops and computer external surfaces.
- d) Damp mop floor and anti-static mat.
- e) Lift instruments and dust generator (carefully) and wipe bottom surface and table tops.

C.7 Test room cleaning procedures (shutdown and as required)

NOTE These procedures were written for a specific facility and should be regarded as typical. They have been found to be sufficient to achieve required test chamber background concentrations.

- a) Prepare anti-static cleaning solution (commercially available formula acceptable) in accordance with manufacturer's instructions. Use only damp sponge and mop (no dripping or sloshing).
- b) Mop ceiling - Damp mop ceiling, including light fixture lenses. Rinse, wring out mop and change water frequently during mopping.

- c) Mop walls - Starting at wall next to door, damp mop walls in sections, working around the room. Rinse, wring out mop and change water frequently during mopping.
- d) Wash window - Wash with anti-static solution. Wipe with lint-free wipes.
- e) Sponge - Start at door, working around the room, using the sponge on all small surfaces. Rinse and wring out sponge frequently. Clean surfaces.
 - Ceiling fan, including braces (perform first).
 - Door, knob, closer and molding.
 - Temperature and RH sensor covers.
 - Small sections of wall.
 - Return air damper, linkage, and motor.
 - Recirculation fan and bracket, including fan blades.
 - Dust generator and pedestal.
 - Second return air damper, linkage, and motor.
 - Instrument and table tops and legs.
- f) Mop floor - Damp mop room floor, starting at corner farthest from the door and working in sections toward the door. Rinse, wring out mop, and change water frequently during mopping.

C.8 Short term maintenance and calibration procedures

- a) Perform tracer gas analysis on test chamber to determine air leakage rate at least within 6-month intervals.

NOTE The frequency of the tracer gas analysis checks should be increased if results during six month checks are not stable.

- b) Check test chamber interior walls, ceiling and joints for damage and repair as necessary.
- c) Blow out APS 3321 chassis every two weeks using 1,4 kg/cm² to 2,8 kg/cm² (20 psig to 40 psig) filtered compressed air.

C.9 Long term maintenance and calibration procedures

- a) Return APS 3321 and HS-LAS particle counters to the manufacturer for cleaning and calibration annually.
- b) Paint interior walls and ceiling of test chamber annually using white, washable latex semi-gloss paint (Annex A).
- c) Calibrate the watt meter used for the operating power test to a standard traceable to the National Institute of Standards and Technology (NIST) on an annual basis.

Annex D (informative)

Standardization of calculations — Rounding procedures for data and calculations

D.1 Raw data

Round raw data to four (4) significant figures.

- Dust: 111,12 = 111,1
- Cigarette: 22 222 = 22 220
- Pollen: 9,666 6 = 9,667

D.2 Slope of decay line

Round the slope of decay line to five (5) decimal places.

- 0,156 743 23 = 0,156 74
- 0,013 267 81 = 0,013 27

D.3 CADR and estimated value of two sigma

Round to one (1) decimal place for tabulation and calculation

- 150,324 5 = 150,3

Round to nearest whole number for certification, verification or other formal reporting.

- 150,3 = 150

The standard deviation of the slope of the regression line will be rounded to four (4) significant figures prior to computing the two sigma estimate.

Annex E (informative)

Derivation of effective room size

NOTE The AHAM Effective Room Size is based on several standard construction criteria for rooms, and a history of the natural decay rate of small particles as determined through ANSI/AHAM AC-1 for cigarette smoke.

E.1 Basic indoor air model for particle concentrations

Concentrations of particles in indoor air are dynamic and result from the competition between various source and removal processes. Steady state can be defined as when neither the source nor the removal processes are rapidly changing and thus the indoor concentration is relatively constant. In this situation:

$$C = \frac{\text{source terms}}{\text{removal terms}} = \frac{\text{indoor sources} + \text{outdoor sources}}{\text{ventilation} + \text{air cleaning} + \text{deposition}} \quad (1)$$

Without air cleaning, particle removal is through ventilation and deposition. Rearranging these terms and substituting decay parameters for words in equation (1):

$$\text{Source terms} = C \times (k_V + k_{dep}) \quad (2)$$

where

k_V is removal rate due to ventilation, expressed in minutes⁻¹;

k_{dep} is the removal rate due to deposition, expressed in minutes⁻¹;

and, when used in equation (3) below,

k_{AC} is the removal rate due to air cleaning, expressed in minutes⁻¹.

Steady-state for cleaning is defined by AHAM Air Cleaner Council as being 20 % or less of the initial particle load in a room, or in other words: at least an 80 % continuous removal of smoke particles. This defines a new steady state particle concentration, now with the air cleaner operating, C_{AC} , which equals $0,2C$. Using the same formula as in equation (2) above:

$$\text{Source terms} = 0,2C \times (k_V + k_{dep} + k_{AC}) \quad (3)$$

Since the source terms do not change – only the use of an air cleaner – the two equations can be combined through the equivalent source terms to give:

$$C \times (k_V + k_{dep}) = 0,2C \times (k_V + k_{dep} + k_{AC}) \quad (4)$$

Cancelling the C 's from both sides, rearranging and solving for the air cleaner removal rate:

$$k_{AC} = 4(k_V + k_{dep}) \quad (5)$$

Recall that CADR is defined as $V \times (k_e - k_n)$, where V is the room volume (ft³) and k_e and k_n are the decay rates with and without air cleaner operation, respectively (as defined in 8.4).

Effectively then:

$$\text{air cleaner operating decay} = k_e = (k_v + k_{\text{dep}} + k_{\text{AC}}) \quad (6)$$

and

$$\text{natural decay} = k_n = (k_v + k_{\text{dep}}) \quad (7)$$

This difference in decay rates is k_{AC} , thus

$$\text{CADR} = V \times k_{\text{AC}} = 4V(k_v + k_{\text{dep}}) \quad (8)$$

The objective is to show what size room results from the minimum air cleaner performance needed to provide an 80 % reduction in steady-state particle concentrations. For simplicity, it is assumed that the ceiling height is 8 ft; this permits recasting of the equation in terms of floor area, A , a more commonly known description of room size than is room volume,

$$A = \frac{\text{CADR}}{32(k_v + k_{\text{dep}})} \quad (9)$$

Commonly accepted values for the two decay parameters are used. Typical air exchange (ventilation) rates for houses in the U.S. is 1 per hour, or $k_v = 0,016\ 67\ \text{min}^{-1}$. For smoke, average deposition rates are $0,003\ 4\ \text{min}^{-1}$, as provide by AHAM through actual measurements by a third party independent laboratory. Substituting these values in equation (9):

$$A(\text{ft})^2 = \text{CADR} / [32(0,016\ 67 + 0,003\ 4)] = 1,557\ \text{CADR (cfm)} \quad (10)$$

In a meeting of the AHAM Air Cleaner Council, the value of 1,557 was rounded to 1,55 for simplicity, thereby providing the standard equation:

$$\text{Square feet} = 1,55\ \text{cfm}$$

CADR. Based on this equation, an air cleaner with a CADR rating of 50 cfm can be used to clean a small room (78 ft²). Likewise a CADR rating of 100 cfm would permit an air cleaner to be used in a 156 ft² room (~10 x 15 ft), and so forth. Conversely, this equation can also be used to determine what the CADR requirement is for a room or indoor space of a given size. For example, for a room size of 100 ft² a CADR rating of at least 64 cfm is needed.

Annex F (informative)

Sample data

F.1 Example data sheet — Cigarette smoke natural

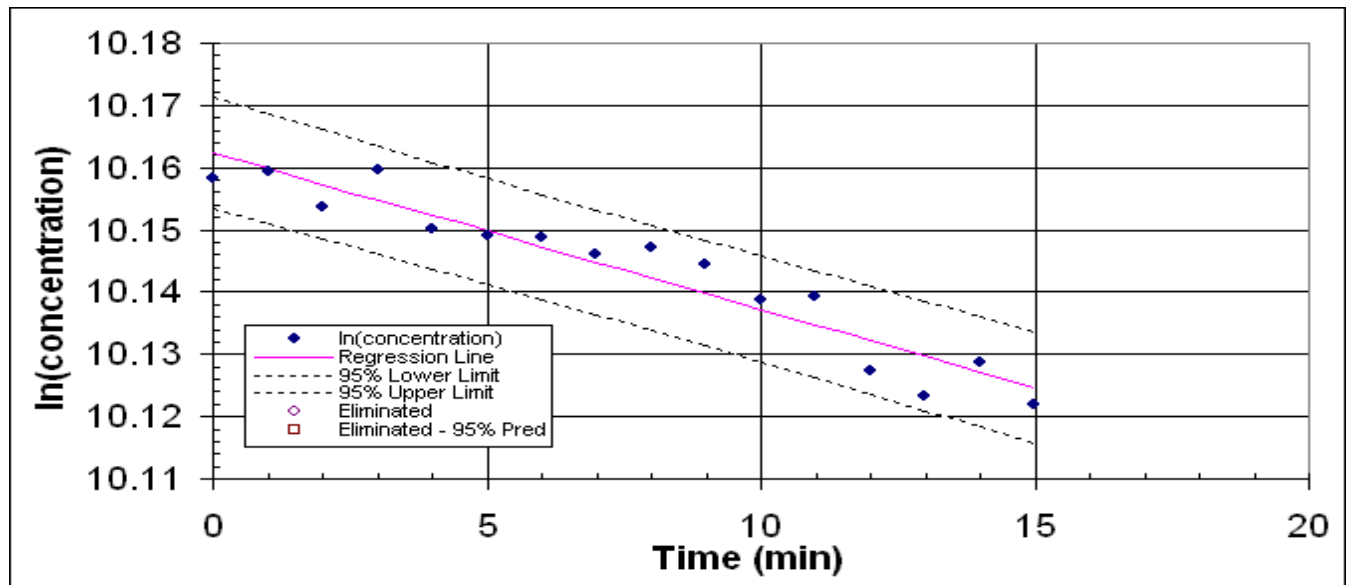

TIME(MIN)	Cti	ln(Cti)	TIME(MIN)	Cti	LN(Cti)
0.00	25,802.39	10.16	11.00	25,320.37	10.14
1.00	25,831.96	10.16	12.00	25,019.76	10.13
2.00	25,682.27	10.15	13.00	24,918.43	10.12
3.00	25,840.89	10.16	14.00	25,051.80	10.13
4.00	25,598.50	10.15	15.00	24,880.55	10.12
5.00	25,568.31	10.15			
6.00	25,559.07	10.15			
7.00	25,492.24	10.15			
8.00	25,515.95	10.15			
9.00	25,448.19	10.14			
10.00	25,305.28	10.14			

Quantity	Measured	Lower Limit	Upper Limit	Acceptable
Decay Constant	0.00251	-	-	
Slope Standard Deviation (min ⁻¹)	0.21	-	2.00	YES
Background at Injection (part/cm ³)	5.236	-	20.00	YES
Initial Concentration (part/cm ³)	25800	24000	35000	YES
Data points used	16	9	-	YES
Average Temperature (°F)	71	65	75	YES
Average Humidity (%RH)	40	35	45	YES
Average Input Voltage (volts)	120.9			
Average Test Unit Power (watts)	0.3			
CADR (cfm)	226.5			
CADR Standard Deviation (cfm)	1.6		22.7	YES

F.2 Example data sheet — Cigarette smoke measured

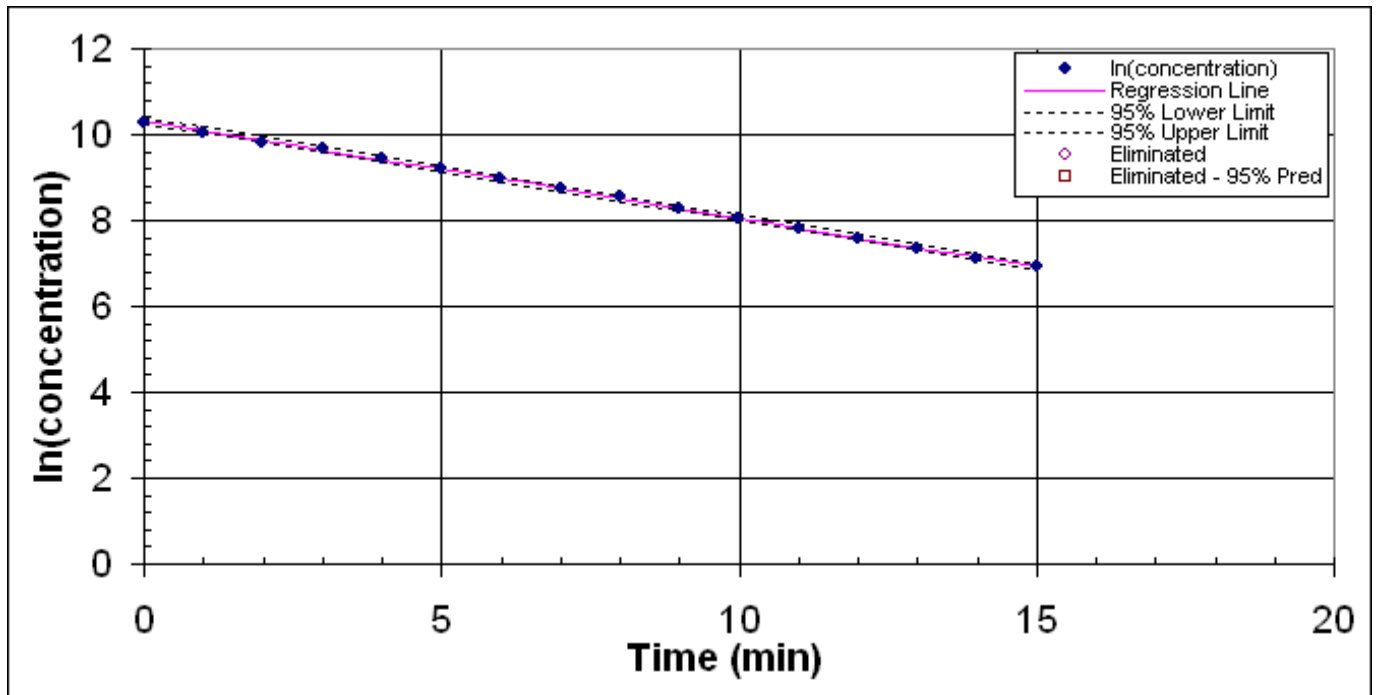

TIME(MIN)	Cti	ln(Cti)	TIME(MIN)	Cti	LN(Cti)
0.00	29,549.52	10.29	11.00	2,458.76	7.81
1.00	23,348.25	10.06	12.00	1,992.14	7.60
2.00	18,686.36	9.84	13.00	1,564.02	7.36
3.00	15,875.55	9.67	14.00	1,245.86	7.13
4.00	12,811.57	9.46	15.00	1,012.09	6.92
5.00	9,949.32	9.21			
6.00	8,030.79	8.99			
7.00	6,396.24	8.76			
8.00	5,189.18	8.55			
9.00	3,886.34	8.27			
10.00	3,052.90	8.02			
Quantity	Measured	Lower Limit	Upper Limit	Acceptable	
Decay Constant	0.22726	-	-		
Slope Standard Deviation (min ⁻¹)	1.63	-	22.91	YES	
Background at Injection (part/cm ³)	8.624	-	20.00	YES	
Initial Concentration (part/cm ³)	29550	24000	35000	YES	
Data points used	16	9	-	YES	
Average Temperature (°F)	71	65	75	YES	
Average Humidity (%RH)	41	35	45	YES	
Average Input Voltage (volts)	120.5				
Average Test Unit Power (watts)	100.8				
CADR (cfm)	226.55				
CADR Standard Deviation (cfm)	1.6		22.7	YES	

F.3 Example data sheet – Dust natural

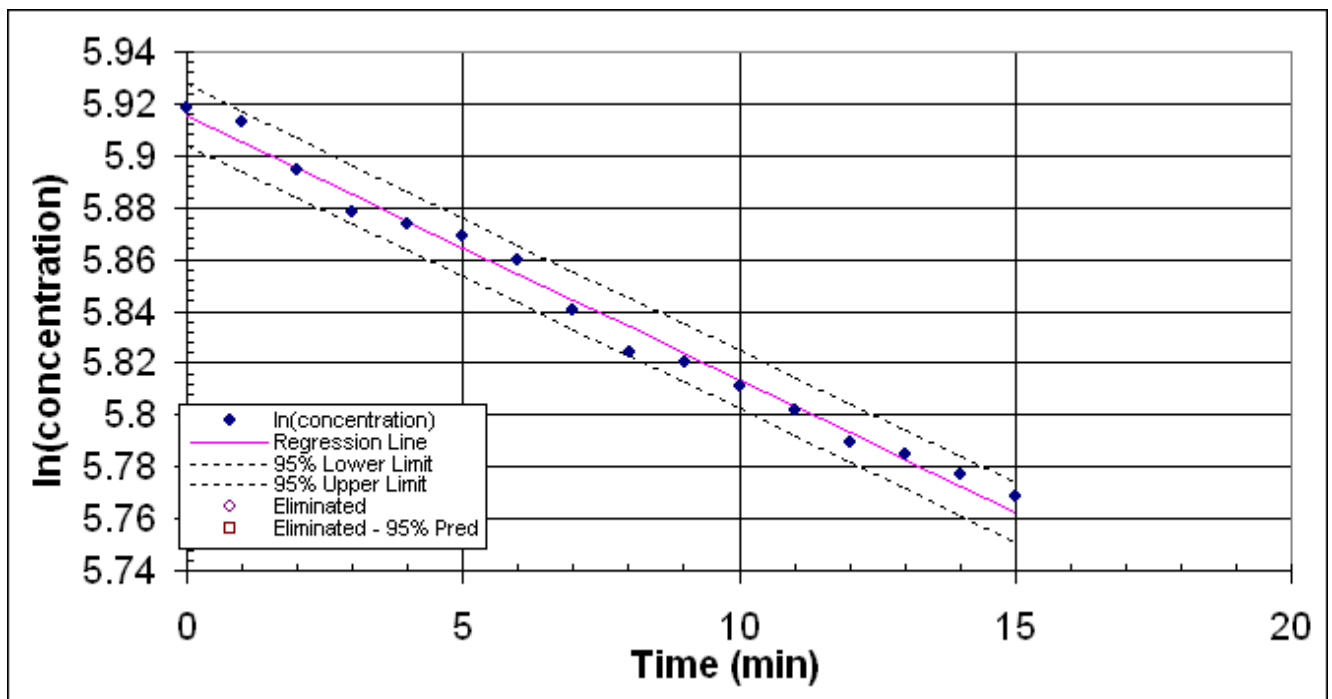

TIME(MIN)	Cti	ln(Cti)	TIME(MIN)	Cti	LN(Cti)
0.00	371.89	5.92	11.00	330.94	5.80
1.00	369.70	5.91	12.00	326.79	5.79
2.00	363.04	5.89	13.00	325.31	5.78
3.00	357.23	5.88	14.00	322.93	5.78
4.00	355.40	5.87	15.00	320.02	5.77
5.00	353.80	5.87			
6.00	350.54	5.86			
7.00	343.87	5.84			
8.00	338.37	5.82			
9.00	337.08	5.82			
10.00	334.01	5.81			

Quantity	Measured	Lower Limit	Upper Limit	Acceptable
Decay Constant	0.01021	-	-	
Slope Standard Deviation (min^{-1})	0.28	-	1.03	YES
Background at Injection (part/cm^3)	0.021	-	0.03	YES
Initial Concentration (part/cm^3)	371.9	200	400	YES
Data points used	16	9	-	YES
Average Temperature ($^{\circ}\text{F}$)	70	65	75	YES
Average Humidity (%RH)	40	35	45	YES
Average Input Voltage (volts)	120.8			
Average Test Unit Power (watts)	0.3			
Coefficient of Determination	0.990	0.980	-	YES
CADR (cfm)	233.51			
CADR Standard Deviation (cfm)	1.3	-	23.4	YES

F.4 Example data sheet — Dust measured

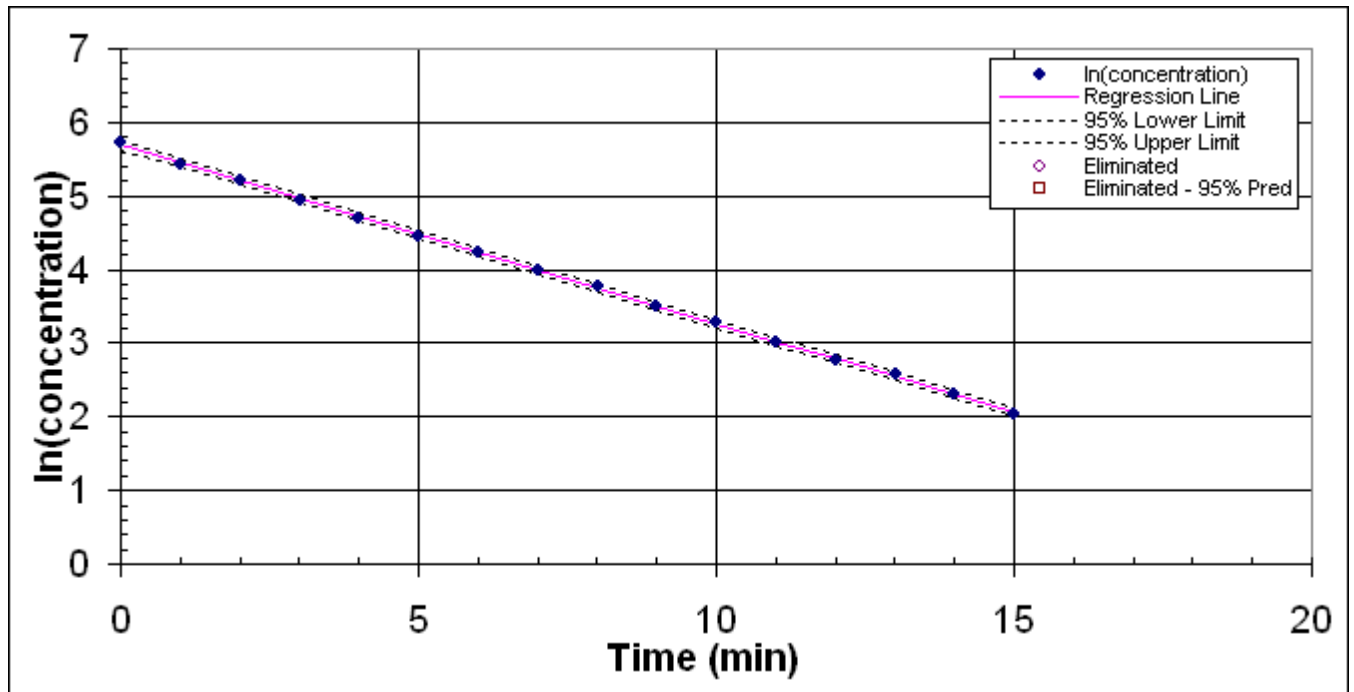

TIME(MIN)	Cti	ln(Cti)	TIME(MIN)	Cti	LN(Cti)
0.00	310.19	5.74	11.00	20.41	3.02
1.00	225.87	5.42	12.00	16.10	2.78
2.00	181.95	5.20	13.00	13.21	2.58
3.00	139.72	4.94	14.00	10.07	2.31
4.00	110.55	4.71	15.00	7.62	2.03
5.00	85.76	4.45			
6.00	69.81	4.25			
7.00	53.35	3.98			
8.00	42.85	3.76			
9.00	32.70	3.49			
10.00	26.68	3.28			

Quantity	Measured	Lower Limit	Upper Limit	Acceptable
Decay Constant	0.24186	-	-	
Slope Standard Deviation (min ⁻¹)	1.3	-	24.38	YES
Background at Injection (part/cm ³)	0.021	-	0.03	YES
Initial Concentration (part/cm ³)	310.2	200	400	YES
Data points used	16	9	-	YES
Average Temperature (°F)	71	65	75	YES
Average Humidity (%RH)	38	35	45	YES
Average Input Voltage (volts)	120.7			
Average Test Unit Power (watts)	97.3			
Coefficient of Determination	1.000	0.980	-	YES
CADR (cfm)	233.51			
CADR Standard Deviation (cfm)	1.3	-	23.4	YES

F.5 Example data sheet — Pollen natural

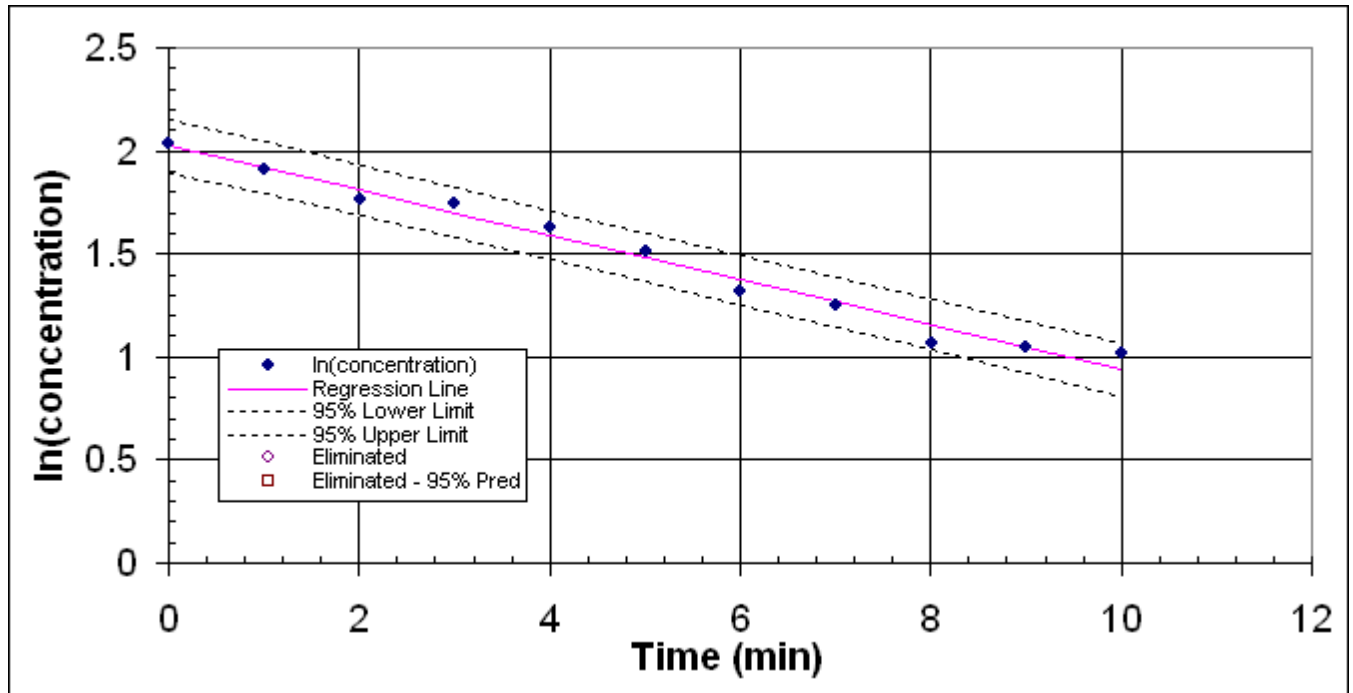

TIME(MIN)	Cti	ln(Cti)	TIME(MIN)	Cti	LN(Cti)
0.00	7.66	2.04			
1.00	6.75	1.91			
2.00	5.84	1.76			
3.00	5.70	1.74			
4.00	5.11	1.63			
5.00	4.54	1.51			
6.00	3.75	1.32			
7.00	3.50	1.25			
8.00	2.90	1.07			
9.00	2.83	1.04			
10.00	2.77	1.02			

Quantity	Measured	Lower Limit	Upper Limit	Acceptable
Decay Constant	0.10849	0.095	0.143	YES
Slope Standard Deviation (min ⁻¹)	4.98	-	10.94	YES
Background at Injection (part/cm ³)	0.021	-	0.03	YES
Initial Concentration (part/cm ³)	7.665	4	9	YES
Data points used	11	5	-	YES
Average Temperature (°F)	70	65	75	YES
Average Humidity (%RH)	39	35	45	YES
Average Input Voltage (volts)	121.0			
Average Test Unit Power (watts)	0.3			
Coefficient of Determination	0.982	0.980	-	YES
CADR (cfm)	197.90			
CADR Standard Deviation (cfm)	9.7	-	39.6	YES

F.6 Example data sheet — Pollen measured

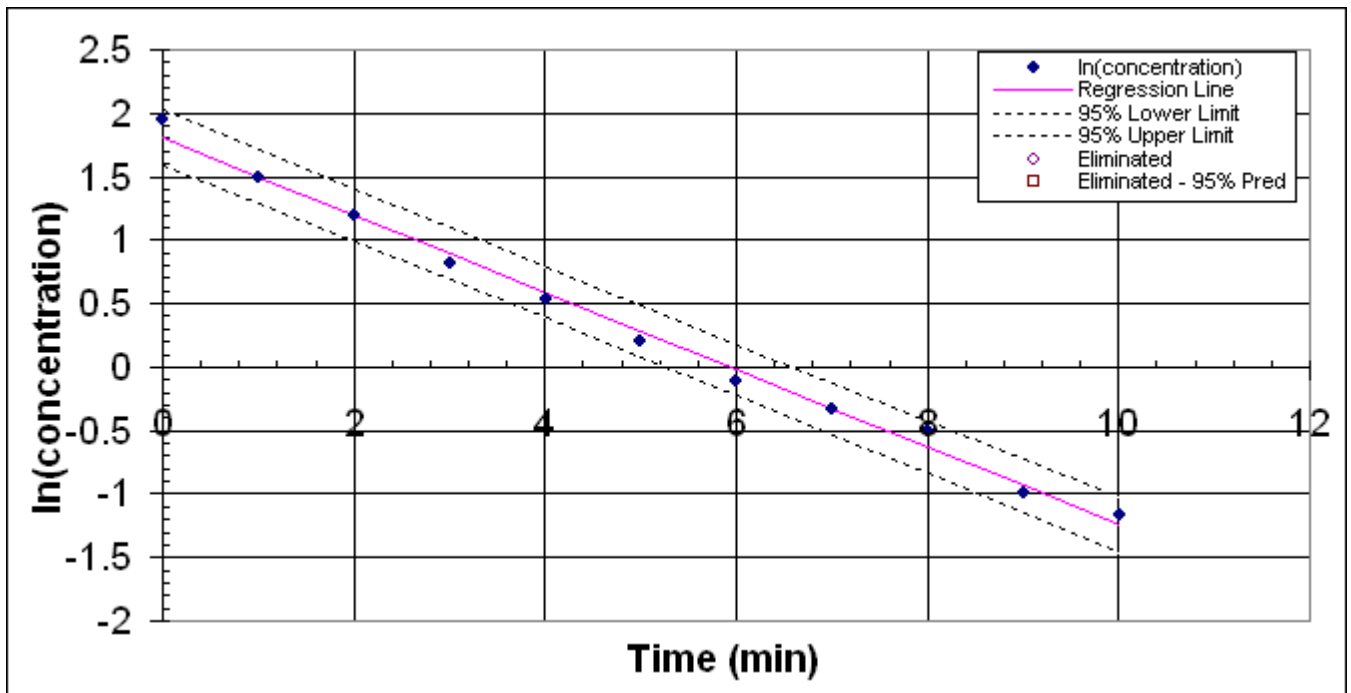

TIME(MIN)	Cti	ln(Cti)	TIME(MIN)	Cti	LN(Cti)
0.00	6.97	1.94			
1.00	4.48	1.50			
2.00	3.32	1.20			
3.00	2.27	0.82			
4.00	1.70	0.53			
5.00	1.22	0.20			
6.00	0.90	-0.11			
7.00	0.72	-0.33			
8.00	0.61	-0.50			
9.00	0.37	-0.99			
10.00	0.31	-1.16			
Quantity	Measured	Lower Limit	Upper Limit	Acceptable	
Decay Constant	0.30482	-	-		
Slope Standard Deviation (min ⁻¹)	8.27	-	30.73	YES	
Background at Injection (part/cm ³)	0.03	-	0.03	YES	
Initial Concentration (part/cm ³)	6.975	4	9	YES	
Data points used	11	5	-	YES	
Average Temperature (°F)	70	65	75	YES	
Average Humidity (%RH)	39	35	45	YES	
Average Input Voltage (volts)	120.7				
Average Test Unit Power (watts)	92.9				
Coefficient of Determination	0.994	0.98	-	YES	
CADR (cfm)	197.90				
CADR Standard Deviation (cfm)	9.7	-	39.6	YES	

Annex G
(informative)

Test stand for wall mount and plug-in type air cleaners

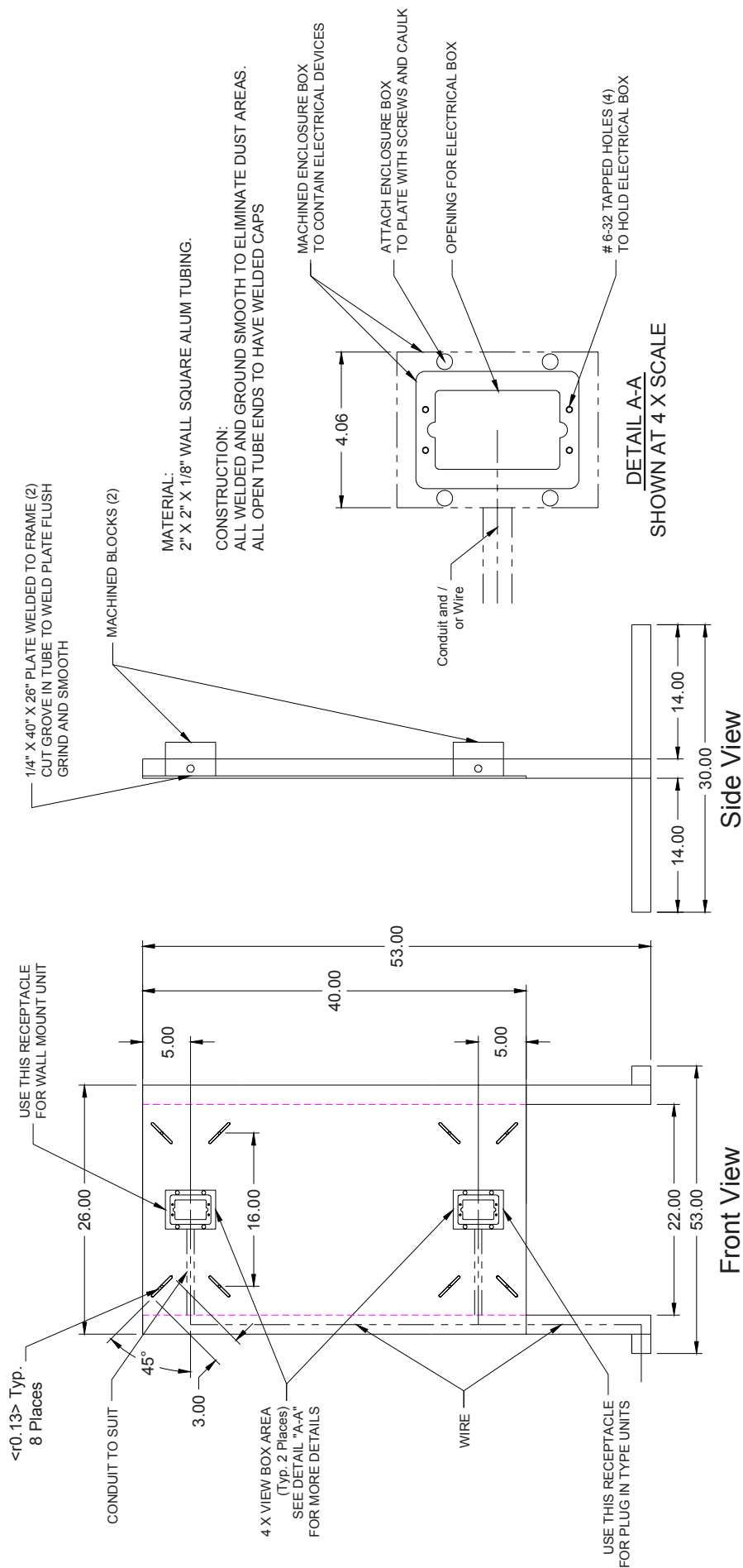

07/01/05

Figure G.1 – Test stand for wall mount and plug-in type air cleaners

Annex H (informative)

Data acquisition — Sequence of steps and timelines

H.1 Sequence of steps

- H.1.1 Clean room thoroughly.
- H.1.2 Set up the air cleaner test sample in the chamber.
- H.1.3 Turn on the test facility lab computer.
- H.1.4 Turn on the chamber environmental control system (humidifiers, HEPA filter, blower, supply dampers and return dampers).
- H.1.5 Turn on the recirculation fan. This fan remains on for the duration of the test.
- H.1.6 Turn on ceiling mixing fan.
- H.1.7 Monitor background concentration level.
- H.1.8 When acceptable background concentration level is obtained, turn off the chamber environmental control system.
- H.1.9 Inject pollutant to specified level.
- H.1.10 Turn off air supply used to inject the pollutant and close pollutant injection valve.
- H.1.11 Allow the pollutant to mix for 1 min (via the mixing fan and recirculation fan).
- H.1.12 Turn off the mixing fan.
- H.1.13 Wait 1 min for the mixing fan to stop.
- H.1.14 Begin particle counter sampling and data acquisition outlined below.
 - d) a) Cigarette smoke
 - i) If this is a measured unit run, turn on test sample now. This is time (t) = 0 min.
 - ii) Wait 2 additional minutes (due to diluter sampling delay) before acquiring data.
 - iii) Begin data acquisition by taking a 20 s (see NOTE) sample at 1 min intervals beginning at $t = 2$ min.
 - iv) Obtain at least 9 data points.
 - b) Dust
 - i) If this is a measured unit run, turn on the test sample now. This is $t = 0$ min.
 - ii) Begin data acquisition by taking 20 s sample at one minute intervals beginning at $t = 0$ min.
 - iii) Obtain at least 9 data points.
 - c) Pollen
 - i) If this is a measured unit run, turn on the test sample now. This is $t = 0$.
 - ii) Begin data acquisition by taking a 20 s (see NOTE) sample at one minute intervals beginning at $t = 0$ min.
 - iii) Obtain at least 5 data points.

NOTE The particle counter sample period is normally 20 s, but will be dependent on the specific instrument used.

H.1.15 Test sequence complete.

H.1.16 Perform data analysis.

H.2 Timeline for cigarette smoke data acquisition

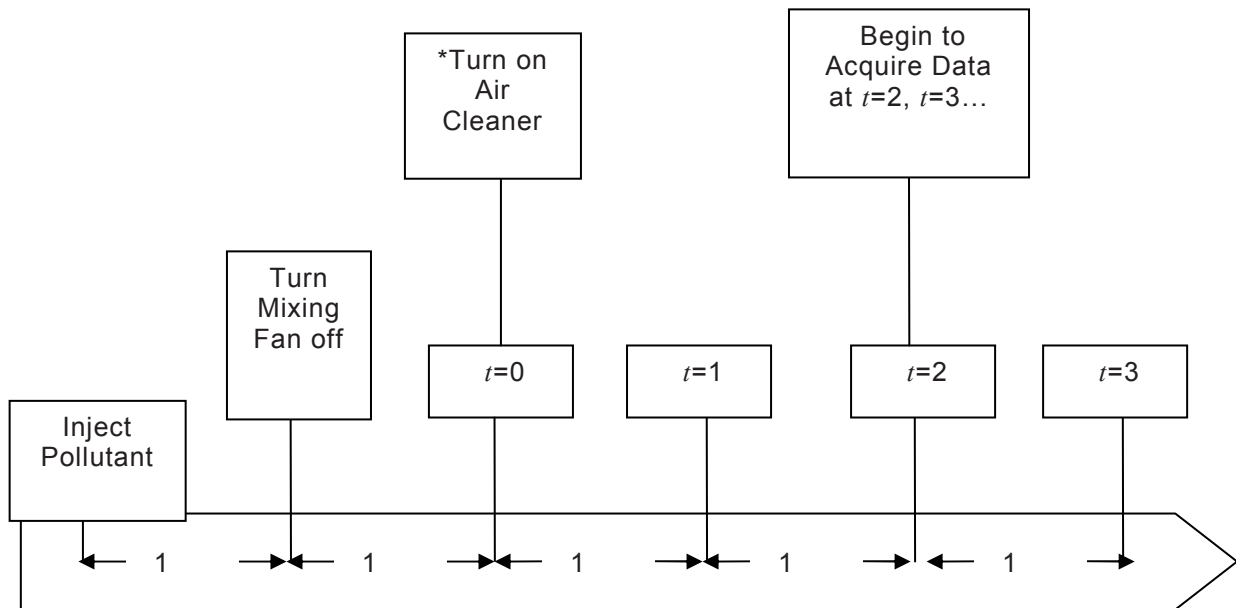

For cigarette smoke, obtain at least 9 data points (over 20 min).
 For natural decay measurements, do not turn on air cleaner*, and begin data acquisition at $t = 2$.

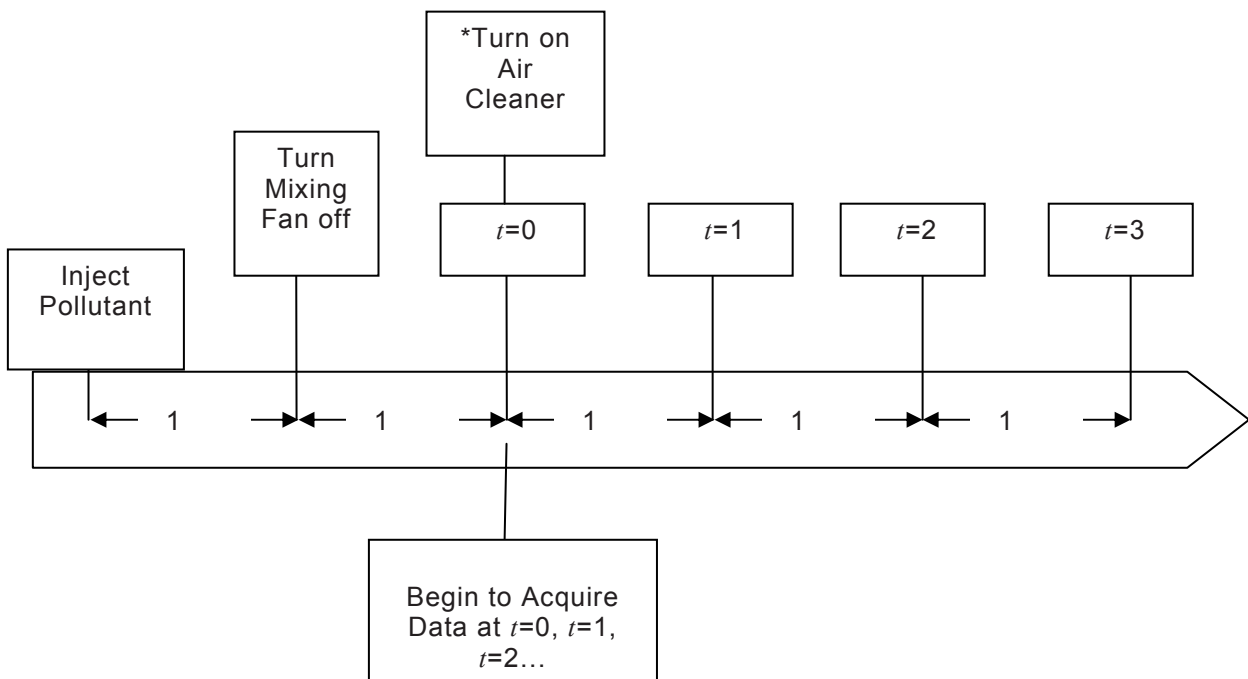

For dust, obtain at least 9 data points (over 20 min).
 For pollen, obtain at least 5 data points (over 10 min).
 For natural decay, do not turn on air cleaner*, and begin data acquisition at $t = 0$.

British Standards Institution (BSI)

BSI is the national body responsible for preparing British Standards and other standards-related publications, information and services.

BSI is incorporated by Royal Charter. British Standards and other standardization products are published by BSI Standards Limited.

About us

We bring together business, industry, government, consumers, innovators and others to shape their combined experience and expertise into standards-based solutions.

The knowledge embodied in our standards has been carefully assembled in a dependable format and refined through our open consultation process. Organizations of all sizes and across all sectors choose standards to help them achieve their goals.

Information on standards

We can provide you with the knowledge that your organization needs to succeed. Find out more about British Standards by visiting our website at bsigroup.com/standards or contacting our Customer Services team or Knowledge Centre.

Buying standards

You can buy and download PDF versions of BSI publications, including British and adopted European and international standards, through our website at bsigroup.com/shop, where hard copies can also be purchased.

If you need international and foreign standards from other Standards Development Organizations, hard copies can be ordered from our Customer Services team.

Subscriptions

Our range of subscription services are designed to make using standards easier for you. For further information on our subscription products go to bsigroup.com/subscriptions.

With **British Standards Online (BSOL)** you'll have instant access to over 55,000 British and adopted European and international standards from your desktop. It's available 24/7 and is refreshed daily so you'll always be up to date.

You can keep in touch with standards developments and receive substantial discounts on the purchase price of standards, both in single copy and subscription format, by becoming a **BSI Subscribing Member**.

PLUS is an updating service exclusive to BSI Subscribing Members. You will automatically receive the latest hard copy of your standards when they're revised or replaced.

To find out more about becoming a BSI Subscribing Member and the benefits of membership, please visit bsigroup.com/shop.

With a **Multi-User Network Licence (MUNL)** you are able to host standards publications on your intranet. Licences can cover as few or as many users as you wish. With updates supplied as soon as they're available, you can be sure your documentation is current. For further information, email bsmusales@bsigroup.com.

BSI Group Headquarters

389 Chiswick High Road London W4 4AL UK

Revisions

Our British Standards and other publications are updated by amendment or revision.

We continually improve the quality of our products and services to benefit your business. If you find an inaccuracy or ambiguity within a British Standard or other BSI publication please inform the Knowledge Centre.

Copyright

All the data, software and documentation set out in all British Standards and other BSI publications are the property of and copyrighted by BSI, or some person or entity that owns copyright in the information used (such as the international standardization bodies) and has formally licensed such information to BSI for commercial publication and use. Except as permitted under the Copyright, Designs and Patents Act 1988 no extract may be reproduced, stored in a retrieval system or transmitted in any form or by any means – electronic, photocopying, recording or otherwise – without prior written permission from BSI. Details and advice can be obtained from the Copyright & Licensing Department.

Useful Contacts:

Customer Services

Tel: +44 845 086 9001

Email (orders): orders@bsigroup.com

Email (enquiries): cservices@bsigroup.com

Subscriptions

Tel: +44 845 086 9001

Email: subscriptions@bsigroup.com

Knowledge Centre

Tel: +44 20 8996 7004

Email: knowledgecentre@bsigroup.com

Copyright & Licensing

Tel: +44 20 8996 7070

Email: copyright@bsigroup.com