

DD CEN/TS 15639:2010



BSI Standards Publication

# Solid recovered fuels — Determination of mechanical durability of pellets

**bsi.**

...making excellence a habit.™

Version correct as of 03/01/2015. (c) The British Standards Institution 2013 Licensed copy: Lee Shau Kee Library, HKUST  
Licensed copy: Lee Shau Kee Library, HKUST, Version correct as of 03/01/2015. (c) The British Standards Institution 2013 Licensed copy: Lee Shau Kee Library, HKUST

### National foreword

This Draft for Development is the UK implementation of CEN/TS 15639:2010. It supersedes DD CEN/TS 15639:2007 which is withdrawn.

#### **This publication is not to be regarded as a British Standard.**

It is being issued in the Draft for Development series of publications and is of a provisional nature. It should be applied on this provisional basis, so that information and experience of its practical application can be obtained.

Comments arising from the use of this Draft for Development are requested so that UK experience can be reported to the international organization responsible for its conversion to an international standard. A review of this publication will be initiated not later than 3 years after its publication by the international organization so that a decision can be taken on its status. Notification of the start of the review period will be made in an announcement in the appropriate issue of *Update Standards*.

According to the replies received by the end of the review period, the responsible BSI Committee will decide whether to support the conversion into an international Standard, to extend the life of the Technical Specification or to withdraw it. Comments should be sent to the Secretary of the responsible BSI Technical Committee at British Standards House, 389 Chiswick High Road, London W4 4AL.

The UK participation in its preparation was entrusted to Technical Committee PTI/17, Solid biofuels.

A list of organizations represented on this committee can be obtained on request to its secretary.

This publication does not purport to include all the necessary provisions of a contract. Users are responsible for its correct application.

© BSI 2010

ISBN 978 0 580 69903 0

ICS 75.160.10

#### **Compliance with a British Standard cannot confer immunity from legal obligations.**

This Draft for Development was published under the authority of the Standards Policy and Strategy Committee on 31 October 2010.

#### **Amendments issued since publication**

Date	Text affected
------	---------------

---

TECHNICAL SPECIFICATION  
SPÉCIFICATION TECHNIQUE  
TECHNISCHE SPEZIFIKATION

**CEN/TS 15639**

September 2010

ICS 75.160.10

Supersedes CEN/TS 15639:2007

English Version

**Solid recovered fuels - Determination of mechanical durability of pellets**

Combustibles solides de récupération - Méthode de détermination de la résistance des granulés

Feste Sekundärbrennstoffe - Bestimmung der mechanischen Festigkeit von Pellets

This Technical Specification (CEN/TS) was approved by CEN on 12 June 2010 for provisional application.

The period of validity of this CEN/TS is limited initially to three years. After two years the members of CEN will be requested to submit their comments, particularly on the question whether the CEN/TS can be converted into a European Standard.

CEN members are required to announce the existence of this CEN/TS in the same way as for an EN and to make the CEN/TS available promptly at national level in an appropriate form. It is permissible to keep conflicting national standards in force (in parallel to the CEN/TS) until the final decision about the possible conversion of the CEN/TS into an EN is reached.

CEN members are the national standards bodies of Austria, Belgium, Bulgaria, Croatia, Cyprus, Czech Republic, Denmark, Estonia, Finland, France, Germany, Greece, Hungary, Iceland, Ireland, Italy, Latvia, Lithuania, Luxembourg, Malta, Netherlands, Norway, Poland, Portugal, Romania, Slovakia, Slovenia, Spain, Sweden, Switzerland and United Kingdom.



EUROPEAN COMMITTEE FOR STANDARDIZATION  
COMITÉ EUROPÉEN DE NORMALISATION  
EUROPÄISCHES KOMITEE FÜR NORMUNG

**Management Centre: Avenue Marnix 17, B-1000 Brussels**

## Contents

	Page
Foreword.....	3
1 Scope .....	4
2 Normative references .....	4
3 Terms and definitions .....	4
4 Principle.....	5
5 Apparatus .....	5
6 Sampling and sample preparation .....	6
7 Procedure .....	7
8 Calculations.....	7
9 Precision.....	7
10 Test report .....	8
Bibliography .....	9

## Foreword

This document (CEN/TS 15639:2010) has been prepared by Technical Committee CEN/TC 343 “Solid recovered fuels”, the secretariat of which is held by SFS.

Attention is drawn to the possibility that some of the elements of this document may be the subject of patent rights. CEN [and/or CENELEC] shall not be held responsible for identifying any or all such patent rights.

This document supersedes CEN/TS 15639:2007.

This document has been prepared under a mandate given to CEN by the European Commission and the European Free Trade Association.

CEN/TS 15639:2007 was not converted into a European Standard as the test method specified in this document was not validated (see [1], [2]).

This document differs from CEN/TS 15639:2007 mainly as follows:

- a) Specifications regarding the sieves to be used changed;
- b) whole document editorially revised.

According to the CEN/CENELEC Internal Regulations, the national standards organizations of the following countries are bound to announce this Technical Specification: Austria, Belgium, Bulgaria, Croatia, Cyprus, Czech Republic, Denmark, Estonia, Finland, France, Germany, Greece, Hungary, Iceland, Ireland, Italy, Latvia, Lithuania, Luxembourg, Malta, Netherlands, Norway, Poland, Portugal, Romania, Slovakia, Slovenia, Spain, Sweden, Switzerland and the United Kingdom.

## 1 Scope

This document specifies a test method for the determination of mechanical durability of pellets. It is intended to be applied by persons and organisations that manufacture, plan, sell, erect or use machinery, equipment, tools and entire plants related to such pellets, and that are involved in producing, purchasing, selling and utilising pellets.

The method specified is not applicable to soft pellets.

## 2 Normative references

The following referenced documents are indispensable for the application of this document. For dated references, only the edition cited applies. For undated references, the latest edition of the referenced document (including any amendments) applies.

prEN 15357:2008, *Solid recovered fuels — Terminology, definitions and descriptions*

prEN 15442, *Solid recovered fuels — Methods for sampling*

prEN 15443, *Solid recovered fuels — Methods for the preparation of the laboratory sample*

CEN/TS 15414-1, *Solid recovered fuels — Determination of moisture content using the oven dry method — Part 1: Determination of total moisture by a reference method*

CEN/TS 15414-2, *Solid recovered fuels — Determination of moisture content using the oven dry method — Part 2: Determination of total moisture by a simplified method*

ISO 3310-2, *Test sieves — Technical requirements and testing — Part 2: Test sieves of perforated metal plate*

## 3 Terms and definitions

For the purposes of this document, the terms and definitions given in prEN 15357:2008 and the following apply.

### 3.1 mechanical durability

measure of resistance of densified fuels towards shocks and/or abrasion as a consequence of handling and transportation processes, characterized by pellets disintegration and fines formation

### 3.2 fines

particles with a diameter less than 1 mm

NOTE Fines characterize the potential of high dust emission.

### 3.3 soft pellet

pellet with a density less than 600 kg/m<sup>3</sup>

## 4 Principle

The test sample is subjected to controlled shocks by collision of pellets against each others and against the walls of a defined rotating test chamber. The mechanical durability is calculated from the mass of sample remaining after separation of abraded and fine broken particles.

## 5 Apparatus

**5.1 Pellet tester**, consisting of a dust tight enclosure, made of rigid material, e.g. a steel plate, aluminium plate or plexiglass, with smooth and flat surfaces, dimensions of 300 mm × 300 mm × 125 mm; capable of rotations of  $(50 \pm 2) \text{ min}^{-1}$  about an axis perpendicular to and centred in the 300 mm sides, with a 230 mm long baffle affixed symmetrically to a diagonal of one 300 mm × 300 mm side of the pellet tester (see Figure 1 and Figure 2).

One leg of this formed angle baffle shall be extended 50 mm into the pellet tester and the other leg securely fastened to the back of the tester. A door may be placed in any side provided that is dustproof. Projections, such as rivets and screws, shall be kept to a minimum and well rounded.

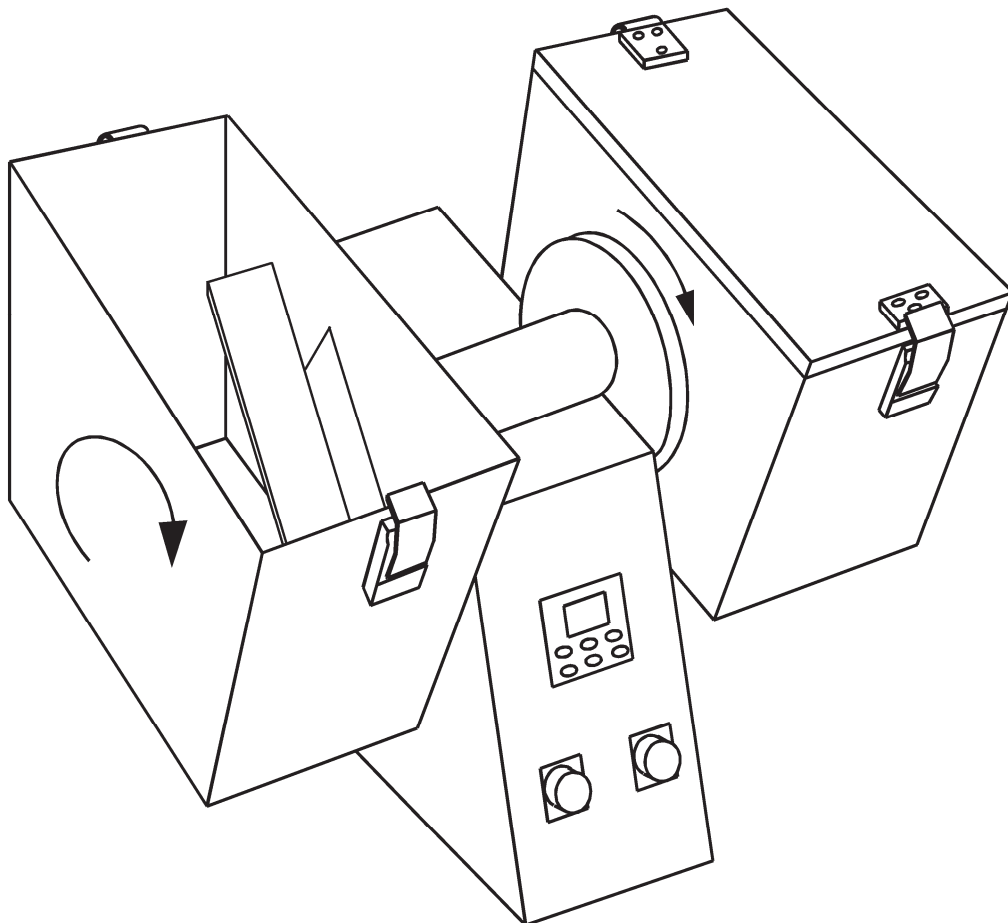
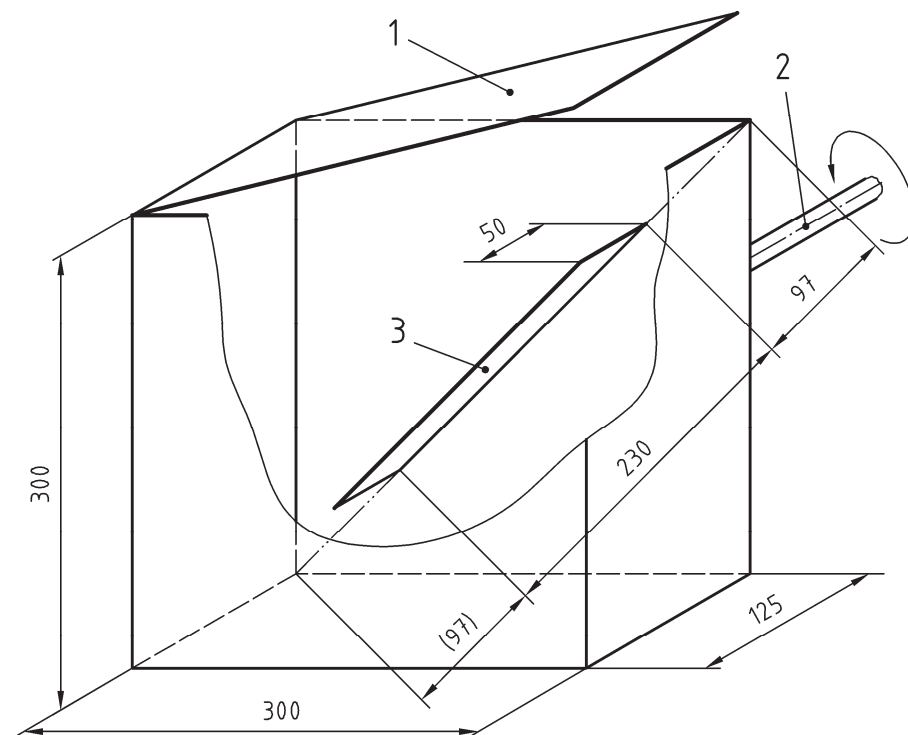

Figure 1 — Example of pellet tester with two boxes

Dimensions in millimetres



#### Key

- 1 filling door
- 2 drive shaft
- 3 baffle

**Figure 2 — Structure of the main parts of the pellet tester**

**5.2 Two sieves**, the first one a round hole sieve with hole sizes of  $\frac{2}{3}$  of the pellets diameter, and the second a 1 mm wire mesh sieve, suitable for manual screening in accordance with ISO 3310-2.

**5.3 Balance**, capable of weighing 2 kg and measuring the mass to the nearest 0,1 g.

## 6 Sampling and sample preparation

The sample shall be taken and prepared in accordance with prEN 15442 and prEN 15443; if necessary, it shall be divided into test portions using the coning and quartering method. The minimum size of the sample shall be 2,5 kg. The sample shall be divided into four equal portions in accordance with prEN 15443. Take one portion for the determination of the total moisture content in accordance with CEN/TS 15414-1 and CEN/TS 15414-2. Weigh two of the remaining sample portions and then separate the pellets carefully by manual sieving using the greater sieve (see 5.2).

**NOTE** Attention should be paid to the fact that rough treatment during sample reduction and screening can influence the result.

Weigh the remaining pellets and determine the initial portion of fines as mass fraction in percent.



## 7 Procedure

A minimum of two determinations shall be carried out on the test sample.

Take a test portion of  $(500 \pm 10)$  g. Place the test portion of the sieved pellets weighed to the nearest 0,1 g in the pellet tester (5.1). Tumble the sample with 500 rotations of  $(50 \pm 2) \text{ min}^{-1}$ . After this number of rotations, the sample shall be removed and passed manually through the sieves (5.2). Weigh the sample remaining on the greater sieve and, if required, the mass of fines less than 1 mm to the nearest 0,1 g.

## 8 Calculations

Calculate the mechanical durability,  $D_p$ , of pellets, expressed as percent, using Equation (1):

$$D_p = \frac{m_{Ap}}{m_{Ep}} \times 100 \quad (1)$$

where

$m_{Ep}$  is the mass of pre-sieved pellets before tumbling treatment, in grams;

$m_{Ap}$  is the mass of sieved pellets after the tumbling treatment, in grams.

The result for each individual determination shall be calculated to two decimal places and the mean value of the individual results shall be calculated and rounded to the nearest 0,1 %. The mean value shall be recorded in the test report.

If required, calculate the mass fraction of fines,  $F_D$ , expressed as percent, using Equation (2):

$$F_D = \frac{m_f}{m_{Ep}} \times 100 \quad (2)$$

where

$m_f$  is the mass of the fraction less than 1 mm.

The individual values of the mass fraction of fines,  $F_D$ , shall be calculated to two decimal places and the mean value of these shall be calculated and rounded to the nearest 0,1 %. The mean value shall be recorded in the test report.

## 9 Precision

The test method specified in this Technical Specification was not validated in the frame of the QUOVADIS project (see [2]).

## **10 Test report**

The test report shall include at least the following information:

- a) Name of the testing laboratory;
- b) Date of the test;
- c) Reference to this document, i.e. "determined in accordance with CEN/TS 15639";
- d) Identification of the product or sample tested;
- e) Number of duplicates tested;
- f) Mean and individual values of the mechanical durability of the tested product or sample as received;
- g) If required, the mass fraction of fines of the tested product or sample as received;
- h) Moisture content of the tested product or sample as received;
- i) Any unusual features observed during the determination which may have affected the test result and details of any operations not included in this document or regarded as optional.

## Bibliography

- [1] CEN Guide 13: *Validation of environmental test methods*, Edition 1, October 2008
- [2] Quality Management, Organisation, Validation of Standards, Developments and Inquiries for SRF (QUOVADIS): *Publishable result-oriented report*, Deliverable D 1.9, December 2007





# British Standards Institution (BSI)

BSI is the national body responsible for preparing British Standards and other standards-related publications, information and services.

BSI is incorporated by Royal Charter. British Standards and other standardization products are published by BSI Standards Limited.

## About us

We bring together business, industry, government, consumers, innovators and others to shape their combined experience and expertise into standards-based solutions.

The knowledge embodied in our standards has been carefully assembled in a dependable format and refined through our open consultation process. Organizations of all sizes and across all sectors choose standards to help them achieve their goals.

## Information on standards

We can provide you with the knowledge that your organization needs to succeed. Find out more about British Standards by visiting our website at [bsigroup.com/standards](http://bsigroup.com/standards) or contacting our Customer Services team or Knowledge Centre.

## Buying standards

You can buy and download PDF versions of BSI publications, including British and adopted European and international standards, through our website at [bsigroup.com/shop](http://bsigroup.com/shop), where hard copies can also be purchased.

If you need international and foreign standards from other Standards Development Organizations, hard copies can be ordered from our Customer Services team.

## Subscriptions

Our range of subscription services are designed to make using standards easier for you. For further information on our subscription products go to [bsigroup.com/subscriptions](http://bsigroup.com/subscriptions).

With **British Standards Online (BSOL)** you'll have instant access to over 55,000 British and adopted European and international standards from your desktop. It's available 24/7 and is refreshed daily so you'll always be up to date.

You can keep in touch with standards developments and receive substantial discounts on the purchase price of standards, both in single copy and subscription format, by becoming a **BSI Subscribing Member**.

**PLUS** is an updating service exclusive to BSI Subscribing Members. You will automatically receive the latest hard copy of your standards when they're revised or replaced.

To find out more about becoming a BSI Subscribing Member and the benefits of membership, please visit [bsigroup.com/shop](http://bsigroup.com/shop).

With a **Multi-User Network Licence (MUNL)** you are able to host standards publications on your intranet. Licences can cover as few or as many users as you wish. With updates supplied as soon as they're available, you can be sure your documentation is current. For further information, email [bsmusales@bsigroup.com](mailto:bsmusales@bsigroup.com).

## BSI Group Headquarters

389 Chiswick High Road London W4 4AL UK



## Revisions

Our British Standards and other publications are updated by amendment or revision.

We continually improve the quality of our products and services to benefit your business. If you find an inaccuracy or ambiguity within a British Standard or other BSI publication please inform the Knowledge Centre.

## Copyright

All the data, software and documentation set out in all British Standards and other BSI publications are the property of and copyrighted by BSI, or some person or entity that owns copyright in the information used (such as the international standardization bodies) and has formally licensed such information to BSI for commercial publication and use. Except as permitted under the Copyright, Designs and Patents Act 1988 no extract may be reproduced, stored in a retrieval system or transmitted in any form or by any means – electronic, photocopying, recording or otherwise – without prior written permission from BSI. Details and advice can be obtained from the Copyright & Licensing Department.

## Useful Contacts:

### Customer Services

**Tel:** +44 845 086 9001

**Email (orders):** [orders@bsigroup.com](mailto:orders@bsigroup.com)

**Email (enquiries):** [cservices@bsigroup.com](mailto:cservices@bsigroup.com)

### Subscriptions

**Tel:** +44 845 086 9001

**Email:** [subscriptions@bsigroup.com](mailto:subscriptions@bsigroup.com)

### Knowledge Centre

**Tel:** +44 20 8996 7004

**Email:** [knowledgecentre@bsigroup.com](mailto:knowledgecentre@bsigroup.com)

### Copyright & Licensing

**Tel:** +44 20 8996 7070

**Email:** [copyright@bsigroup.com](mailto:copyright@bsigroup.com)

...making excellence a habit.™