

# Design of fastenings for use in concrete

## Part 4-5: Post-installed fasteners — Chemical systems

ICS 21.060.99; 91.080.40

## National foreword

This Draft for Development is the UK implementation of CEN/TS 1992-4-5:2009.

**This publication is not to be regarded as a British Standard.**

It is being issued in the Draft for Development series of publications and is of a provisional nature. It should be applied on this provisional basis, so that information and experience of its practical application can be obtained.

Comments arising from the use of this Draft for Development are requested so that UK experience can be reported to the international organization responsible for its conversion to an international standard. A review of this publication will be initiated not later than 3 years after its publication by the international organization so that a decision can be taken on its status. Notification of the start of the review period will be made in an announcement in the appropriate issue of Update Standards.

According to the replies received by the end of the review period, the responsible BSI Committee will decide whether to support the conversion into an international Standard, to extend the life of the Technical Specification or to withdraw it. Comments should be sent to the Secretary of the responsible BSI Technical Committee at British Standards House, 389 Chiswick High Road, London W4 4AL.

The UK participation in its preparation was entrusted to Technical Committee B/525/2, Structural use of concrete.

A list of organizations represented on this committee can be obtained on request to its secretary.

This publication does not purport to include all the necessary provisions of a contract. Users are responsible for its correct application.

**Compliance with a British Standard cannot confer immunity from legal obligations.**

This Draft for Development was published under the authority of the Standards Policy and Strategy Committee on 30 June 2009.

© BSI 2009

ISBN 978 0 580 62639 5

### Amendments/corrigenda issued since publication

Date	Comments

TECHNICAL SPECIFICATION  
SPÉCIFICATION TECHNIQUE  
TECHNISCHE SPEZIFIKATION

**CEN/TS 1992-4-5**

May 2009

ICS 21.060.99; 91.080.40

English Version

**Design of fastenings for use in concrete - Part 4-5: Post-installed  
fasteners - Chemical systems**

Conception-calcul pour les éléments de fixation pour béton  
- Partie 4-5 : Chevilles de fixation - Systèmes chimiques

Bemessung von Befestigungen in Beton - Teil 4-5: Dübel -  
chemische Systeme

This Technical Specification (CEN/TS) was approved by CEN on 20 October 2008 for provisional application.

The period of validity of this CEN/TS is limited initially to three years. After two years the members of CEN will be requested to submit their comments, particularly on the question whether the CEN/TS can be converted into a European Standard.

CEN members are required to announce the existence of this CEN/TS in the same way as for an EN and to make the CEN/TS available promptly at national level in an appropriate form. It is permissible to keep conflicting national standards in force (in parallel to the CEN/TS) until the final decision about the possible conversion of the CEN/TS into an EN is reached.

CEN members are the national standards bodies of Austria, Belgium, Bulgaria, Cyprus, Czech Republic, Denmark, Estonia, Finland, France, Germany, Greece, Hungary, Iceland, Ireland, Italy, Latvia, Lithuania, Luxembourg, Malta, Netherlands, Norway, Poland, Portugal, Romania, Slovakia, Slovenia, Spain, Sweden, Switzerland and United Kingdom.



EUROPEAN COMMITTEE FOR STANDARDIZATION  
COMITÉ EUROPÉEN DE NORMALISATION  
EUROPÄISCHES KOMITEE FÜR NORMUNG

**Management Centre: Avenue Marnix 17, B-1000 Brussels**

## Contents

Page

Foreword.....	3
<b>1</b> <b>Scope .....</b>	<b>4</b>
<b>1.1</b> <b>General.....</b>	<b>4</b>
<b>2</b> <b>Normative references .....</b>	<b>4</b>
<b>3</b> <b>Definitions and symbols .....</b>	<b>4</b>
<b>4</b> <b>Basis of design .....</b>	<b>5</b>
<b>4.1</b> <b>General.....</b>	<b>5</b>
<b>5</b> <b>Determination of action effects .....</b>	<b>5</b>
<b>6</b> <b>Verification of ultimate limit state by elastic analysis .....</b>	<b>5</b>
<b>6.1</b> <b>General.....</b>	<b>5</b>
<b>6.2</b> <b>Tension load.....</b>	<b>6</b>
<b>6.2.1</b> <b>Required verifications .....</b>	<b>6</b>
<b>6.2.2</b> <b>Steel failure.....</b>	<b>6</b>
<b>6.2.3</b> <b>Concrete cone failure .....</b>	<b>8</b>
<b>6.2.4</b> <b>Splitting failure.....</b>	<b>14</b>
<b>6.3</b> <b>Shear load.....</b>	<b>15</b>
<b>6.3.1</b> <b>Required verifications .....</b>	<b>15</b>
<b>6.3.2</b> <b>Steel failure.....</b>	<b>15</b>
<b>6.3.3</b> <b>Concrete pry-out failure .....</b>	<b>16</b>
<b>6.3.4</b> <b>Concrete edge failure .....</b>	<b>17</b>
<b>6.4</b> <b>Combined tension and shear load .....</b>	<b>23</b>
<b>6.4.1</b> <b>Steel failure decisive for tension and shear load .....</b>	<b>23</b>
<b>6.4.2</b> <b>Other modes of failure decisive .....</b>	<b>24</b>
<b>7</b> <b>Fatigue .....</b>	<b>24</b>
<b>8</b> <b>Seismic .....</b>	<b>24</b>

## Foreword

This Technical Specification (CEN/TS 1992-4-5:2009) has been prepared by Technical Committee CEN/TC 250 "Structural Eurocodes", the secretariat of which is held by BSI.

Attention is drawn to the possibility that some of the elements of this document may be the subject of patent rights. CEN [and/or CENELEC] shall not be held responsible for identifying any or all such patent rights.

This Technical Specification CEN/TS 1992-4-5 – Post-installed fasteners – Chemical systems, describes the principles and requirements for safety, serviceability and durability of post-installed fasteners with chemical anchorage systems for use in concrete.

This Technical Specification does not provide information about the use of National Determined Parameters (NDP).

CEN/TS 1992-4-5 is based on the limit state concept used in conjunction with a partial factor method.

CEN/TS 1992-4 'Design of fastenings for use in concrete' is subdivided into the following parts:

- *Part 1: General*
- *Part 2: Headed fasteners*
- *Part 3: Anchor channels*
- *Part 4: Post-installed fasteners – Mechanical systems*
- *Part 5: Post-installed fasteners – Chemical systems*

### Connection to Part 1 of this Technical Specification TS

The principles and requirements of Part 5 of this CEN/TS are additional to those in Part 1, all the clauses and subclauses of which also apply to Part 5 unless varied in this Part. Additional information is presented under the relevant clauses/sub-clauses of Part 1 of the CEN/TS. The numbers for the clauses/sub-clauses of Part 5 continue from the number of the last relevant clauses/sub-clauses of Part 1.

The above principles also apply to Figures and Tables in Part 5.

According to the CEN/CENELEC Internal Regulations, the national standards organizations of the following countries are bound to announce this Technical Specification: Austria, Belgium, Bulgaria, Cyprus, Czech Republic, Denmark, Estonia, Finland, France, Germany, Greece, Hungary, Iceland, Ireland, Italy, Latvia, Lithuania, Luxembourg, Malta, Netherlands, Norway, Poland, Portugal, Romania, Slovakia, Slovenia, Spain, Sweden, Switzerland and the United Kingdom.

## 1 Scope

### 1.1 General

**1.1.6** This document relies on characteristic resistances and distances which are stated in a European Technical Specification. In general the design concept is valid in the product dimensions  $6 \leq h_{ef}/d_{nom} \leq 20$ . The actual range for a particular fastener may be taken from the relevant European Technical Specification. In minimum the following characteristics should be given in the relevant European Technical Specification as base for the design method of this CEN/TS.

- $N_{Rk,s}, V_{Rk,s}$
- $M_{Rk,s}^0$
- $\tau_{Rk}$
- $c_{cr,N}, s_{cr,N}$
- $c_{cr,sp}, s_{cr,sp}$
- $c_{min}, s_{min}$
- $h_{min}$
- limitations on concrete strength classes of base material
- $k_{cr}, k_{ucr}, k_T, k_2, k_3, k_4, k_8$
- $d_{nom}, h_{ef}, l_f$ , limitations on  $h_{ef}/d_{nom}$
- $\gamma_{Mi}$ , recommended partial factors see CEN/TS 1992-4-1:2009, clause 4

## 2 Normative references

This European Standard incorporates by dated or undated reference, provisions from other publications. These normative references are cited at the appropriate places in the text and the publications are listed hereafter. For dated references, subsequent amendments to or revisions of any of these publications apply to this European Standard only when incorporated in it by amendment or revision. For undated references the latest edition of the publication referred to applies.

NOTE The following references to Eurocodes are references to European Standards and European Prestandards. These are the only European documents available at the time of publication of this TS. National documents take precedence until Eurocodes are published as European Standards.

EN 1992-1-1, *Eurocode 2 — Design of concrete structures — Part 1-1: General rules and rules for buildings*

CEN/TS 1992-4-1:2009, *Design of fastenings for use in concrete — Part 4-1: General*

## 3 Definitions and symbols

Definitions and symbols are given in CEN/TS 1992-4-1.

## 4 Basis of design

### 4.1 General

**4.5.4** The following assumptions in respect to installation have been made in this CEN/TS. The installation instructions should reflect them:

- 1) Concrete has been compacted adequately in the area of the fastening. This should be checked prior and during installation via visual check.
- 2) Requirements for drilling operation and bore hole:
  - Holes are drilled perpendicular to the surface of the concrete unless specifically required otherwise by the manufacturer's instructions.
  - Drilling is carried out by method specified by the manufacturer.
  - When hard metal hammer-drill bits are used, they should comply with ISO or National Standards.
  - When diamond core drilling is permitted, the diameter of the segments should comply with the prescribed diameter.
  - Reinforcement in close proximity to the hole position is not damaged during drilling. In prestressed concrete structures it is ensured that the distance between the drilling hole and the prestressed reinforcement is at least 50mm; for determination of the position of the prestressed reinforcement in the structure a suitable device e.g. a reinforcement detector is used.
  - Holes are cleaned according to the instructions given in the European Technical Specification.
  - Aborted drill holes are filled with high strength non-shrinkage mortar.
- 3) Inspection and approval of the correct installation of the fasteners is carried out by appropriately qualified personnel.

NOTE Many drill bits exhibit a mark indicating that they are in accordance with ISO or National Standards. If the drill bits do not bear a conformity mark, evidence of suitability should be provided.

## 5 Determination of action effects

The determination and analysis of the condition of the concrete – cracked or non-cracked - serving as base material for the fastener and of the loads acting on the fastener is given in CEN/TS 1992-4-1:2009, clause 5.

## 6 Verification of ultimate limit state by elastic analysis

### 6.1 General

**6.1.5** This section applies when forces on the fasteners have been calculated using elastic analysis. CEN/TS 1992-4-1:2009, Annex B should be used for plastic analysis.

**6.1.6** The spacing between outer post-installed fasteners of adjoining groups or the distance to single fasteners shall be  $a > s_{cr,N}$ .

**6.1.7** Aborted drill holes filled with high strength non-shrinkage mortar do not have to be considered in the design of the fastenings.

## 6.2 Tension load

### 6.2.1 Required verifications

The required verifications are given in Table 1.

**Table 1 — Verification for post-installed fasteners loaded in tension**

	Single fastener	Fastener group <sup>1)</sup>	
		most loaded fastener	fastener group
<b>1 Steel failure</b>	$N_{Ed} \leq N_{Rd,s} = N_{Rk,s} / \gamma_{Ms}$	$N_{Ed}^h \leq N_{Rd,s} = N_{Rk,s} / \gamma_{Ms,s}$	
<b>2 Combined pull-out and concrete failure</b>	$N_{Ed} \leq N_{Rd,p} = N_{Rk,p} / \gamma_{Mp}$		$N_{Ed}^g \leq N_{Rd,p} = N_{Rk,p} / \gamma_{Mp}$
<b>3 Concrete cone failure</b>	$N_{Ed} \leq N_{Rd,c} = N_{Rk,c} / \gamma_{Mc}$		$N_{Ed}^g \leq N_{Rd,c} = N_{Rk,c} / \gamma_{Mc}$
<b>4 Splitting failure</b>	$N_{Ed} \leq N_{Rd,sp} = N_{Rk,sp} / \gamma_{Msp}$		$N_{Ed}^g \leq N_{Rd,sp} = N_{Rk,sp} / \gamma_{Msp}$

1) Verification is performed only for the fasteners of a group loaded in tension.

### 6.2.2 Steel failure

The characteristic resistance of a fastener in case of steel failure  $N_{Rk,s}$  is given in the relevant European Technical Specification. The strength calculations are based on  $f_{uk}$ .

#### Combined pull-out and concrete failure

The characteristic resistance of a fastener, a group of fasteners and the tensioned fasteners of a group of fasteners in case of combined pull-out and concrete failure may be obtained by Equation (1).

$$N_{Rk,p} = N_{Rk,p}^0 \cdot \frac{A_{p,N}}{A_{p,N}^0} \cdot \psi_{s,Np} \cdot \psi_{g,Np} \cdot \psi_{re,N} \cdot \psi_{ec,Np} \quad [N] \quad (1)$$

The different factors of Equation (1) are given below.

NOTE This verification is necessary only in the case that  $\tau_{Rk} < \tau_{Rk,max} \cdot \tau_{Rk}$ , see Equation (2), and  $\tau_{Rk,max}$ , see Equation (8)

#### 6.2.2.1 Basic resistance of a single fastener

The characteristic resistance of a single bonded fastener  $N_{Rk,p}^0$  not influenced by adjacent bonded fasteners or edges of the concrete member is:

$$N_{Rk,p}^0 = \tau_{Rk} \cdot \pi \cdot d \cdot h_{ef} \quad (2)$$

with



$\tau_{Rk}$  [N/mm<sup>2</sup>] characteristic bond resistance, depending on the concrete strength class, values given for non-cracked ( $\tau_{Rk,ucr}$ ) or cracked concrete ( $\tau_{Rk,cr}$ ) in the corresponding European Technical Specification

$d$  [mm] diameter of the anchor rod or outer diameter of internally threaded sleeves

$h_{ef}$  [mm] embedment depth

### 6.2.2.2 Effect of axial spacing and edge distances

The geometric effect of axial spacing and edge distance on the characteristic resistance is taken into account by the value  $A_{p,N} / A_{p,N}^0$ , where

$$A_{p,N}^0 = s_{cr,Np} \cdot s_{cr,Np}, \text{ reference bond influence area of an individual fastener} \quad (3)$$

$A_{p,N}$  actual bond influence area, limited by overlapping areas of adjacent fasteners ( $s \leq s_{cr,Np}$ ) as well as by edges of the concrete member ( $c \leq c_{cr,Np}$ ).

$$s_{cr,Np} = 7,3 \cdot d \cdot \sqrt{\tau_{Rk}} \leq 3h_{ef} \quad (4)$$

$d$  [mm],  $\tau_{Rk}$  [N/mm<sup>2</sup>], value for non-cracked concrete C20/25

$$c_{cr,Np} = s_{cr,Np}/2 \quad (5)$$

NOTE  $A_{p,N}^0$  and  $A_{p,N}$  are calculated similar to the reference projected area  $A_{c,N}^0$  and the actual projected area  $A_{c,N}$  in case of concrete cone failure (see Figures 1 and 2). However, then the values  $s_{cr,N}$  and  $c_{cr,N}$  are replaced by the values  $s_{cr,Np}$  and  $c_{cr,Np}$ . The value  $s_{cr,Np}$  calculated according Equ. (4) is valid for cracked and uncracked concrete.

### 6.2.2.3 Effect of closely spaced fasteners

The factor  $\psi_{g,Np}$  takes account of a group effect, if the fasteners are closely spaced.

$$\psi_{g,Np} = \psi_{g,Np}^0 - \left(\frac{s}{s_{cr,Np}}\right)^{0,5} \cdot (\psi_{g,Np}^0 - 1) \geq 1 \quad [-] \quad (6)$$

with

$$\psi_{g,Np}^0 = \sqrt{n} - (\sqrt{n} - 1) \cdot \left(\frac{\tau_{Rk}}{\tau_{Rk,max}}\right)^{1,5} \geq 1 \quad (7)$$

$n$  number of bonded anchors of a group [-]

$\tau_{Rk}$  [N/mm<sup>2</sup>] characteristic bond resistance, depending on the concrete strength class, values given for non-cracked ( $\tau_{Rk,ucr}$ ) or cracked concrete ( $\tau_{Rk,cr}$ ) in the corresponding European Technical Specification

$$\tau_{Rk,max} = \frac{k_8}{\pi \cdot d} \sqrt{h_{ef} \cdot f_{ck,cube}} \quad (8)$$

$k_8$  given in the relevant European Technical Specification for cracked and non-cracked concrete [-]

$f_{ck,cube}$  [N/mm<sup>2</sup>] characteristic cube strength of the concrete strength class but noting the limitations given in the relevant European Technical Specification.

$s$  spacing [mm], in case of multiple spacings the mean value of the spacings should be used

$s_{cr,Np}$  characteristic spacing, see Equation (4)

NOTE According to current experience the value for  $k_8$  is 7,2 for applications in cracked concrete and  $k_8 = 10,1$  for applications in non-cracked concrete.

#### 6.2.2.4 Effect of the disturbance of stresses in the concrete

The factor  $\psi_{s,Np}$  takes account of the disturbance of the distribution of stresses in the concrete due to edges of the concrete member. For fastenings with several edge distances (e.g. fastening in a corner of the concrete member or in a narrow member), the smallest edge distance  $c$  shall be inserted in Equation (9).

$$\psi_{s,Np} = 0,7 + 0,3 \cdot \frac{c}{c_{cr,Np}} \leq 1 \quad [-] \quad (9)$$

#### 6.2.2.5 Effect of shell spalling

The shell spalling factor  $\psi_{re,N}$  takes account of the effect of a dense reinforcement for embedment depths  $h_{ef} < 100$  mm:

$$\psi_{re,N} = 0,5 + \frac{h_{ef}}{200} \leq 1 \quad [-] \quad (10)$$

with:  $h_{ef}$  [mm]

Irrespective of the embedment depth of the fastener,  $\psi_{re,N}$  may be taken as 1,0 in the following cases:

- 1) Reinforcement (any diameter) is provided at a spacing  $\geq 150$ mm, or
- 2) Reinforcement with a diameter of 10 mm or less is provided at a spacing  $\geq 100$  mm.

#### 6.2.2.6 Effect of the eccentricity of the load

The factor  $\psi_{ec,Np}$  takes account of a group effect when different tension loads are acting on the individual fasteners of a group.

$$\psi_{ec,Np} = \frac{1}{1 + 2 \cdot e_N / s_{cr,Np}} \leq 1 \quad [-] \quad (11)$$

with:  $e_N$ : eccentricity of the resulting tensile load acting on the tensioned fasteners (see CEN/TC 1992-4-1:2009, 5.2).

Where there is an eccentricity in two directions,  $\psi_{ec,Np}$  shall be determined separately for each direction and the product of both factors shall be inserted in Equation (1).

#### 6.2.3 Concrete cone failure

The characteristic resistance of a single tensioned fastener and a group of tensioned fasteners in case of concrete cone failure may be obtained by Equation (12).

$$N_{Rk,c} = N_{Rk,c}^0 \cdot \frac{A_{c,N}}{A_{c,N}^0} \cdot \psi_{s,N} \cdot \psi_{re,N} \cdot \psi_{ec,N} \quad [N] \quad (12)$$

The different factors of Equation (12) are given below.

### 6.2.3.1 Characteristic resistance of a single fastener

#### — Cracked concrete:

The characteristic resistance of a single fastener placed in cracked concrete and not influenced by adjacent fasteners or edges of the concrete member is obtained by:

$$N_{Rk,c}^0 = k_{cr} \cdot \sqrt{f_{ck,cube}} \cdot h_{ef}^{1,5} \quad [N] \quad (13)$$

where  $k_{cr}$  factor to take into account the influence of load transfer mechanisms for applications in cracked concrete, the actual value is given in the corresponding European Technical Specification.

$f_{ck,cube}$  [N/mm<sup>2</sup>] characteristic cube strength of the concrete strength class but noting the limitations given in the relevant European Technical Specification.

$h_{ef}$  [mm] see CEN/TS 1992-4-1:2009, Figure 5, the actual value is given in the corresponding European Technical Specification.

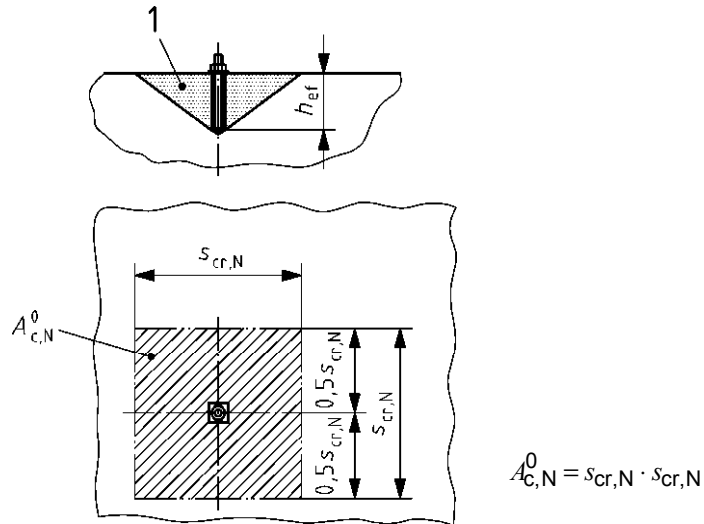
NOTE For fasteners according to current experience the value is 7,2 or 8,5. The actual value for a particular fastener may be taken from the relevant European Technical Specification.

#### — Non-cracked concrete:

The characteristic resistance of a single fastener placed in non-cracked concrete and not influenced by adjacent fasteners or edges of the concrete member is obtained by:

$$N_{Rk,c}^0 = k_{ucr} \cdot \sqrt{f_{ck,cube}} \cdot h_{ef}^{1,5} \quad [N] \quad (14)$$

with  $k_{ucr}$  factor to take into account the influence of load transfer mechanisms for applications in non-cracked concrete, the actual value is given in the corresponding European Technical Specification.



**Key**

1 Idealised concrete break-out body

**Figure 1 — Idealised concrete cone and area  $A_{c,N}^0$  of concrete cone of an individual fastener**

**6.2.3.2 Geometric effect of axial spacing and edge distance**

The geometric effect of axial spacings and edge distances on the characteristic resistance is taken into account by the value  $A_{c,N} / A_{c,N}^0$ , where

$A_{c,N}^0$  : = reference projected area, see Figure 1  
 =  $s_{cr,N} \cdot s_{cr,N}$  (15)

$A_{c,N}$  actual area, limited by overlapping concrete cones of adjacent fasteners ( $s \leq s_{cr,N}$ ) as well as by edges of the concrete member ( $c \leq c_{cr,N}$ ). Examples for the calculation of  $A_{c,N}$  are given in Figure 2.

$s_{cr,N}$ ,  $c_{cr,N}$  given in the corresponding European Technical Specification

NOTE For post-installed fasteners according to current experience  $s_{cr,N} = 2c_{cr,N} = 3h_{ef}$ .

**6.2.3.3 Effect of the disturbance of the distribution of stresses in the concrete due to edges**

The factor  $\psi_{s,N}$  takes account of the disturbance of the distribution of stresses in the concrete due to edges of the concrete member. For fastenings with several edge distances (e.g. fastening in a corner of the concrete member or in a narrow member), the smallest edge distance  $c$  shall be inserted in Equation (16).

$$\psi_{s,N} = 0,7 + 0,3 \cdot \frac{c}{c_{cr,N}} \leq 1 \quad [-] \quad (16)$$

**6.2.3.4 Effect of shell spalling**

The shell spalling factor  $\psi_{re,N}$  takes account of the effect of a dense reinforcement for embedment depths  $h_{ef} < 100$  mm:

$$\psi_{re,N} = 0,3 + \frac{h_{ef}}{200} \leq 1 \quad [-] \quad (17)$$

with:  $h_{ef}$  [mm]

Irrespective of the embedment depth of the fastener,  $\psi_{re,N}$  may be taken as 1,0 in the following cases:

- 1) Reinforcement (any diameter) is provided at a spacing  $\geq 150$ mm, or
- 2) Reinforcement with a diameter of 10 mm or less is provided at a spacing  $\geq 100$  mm.

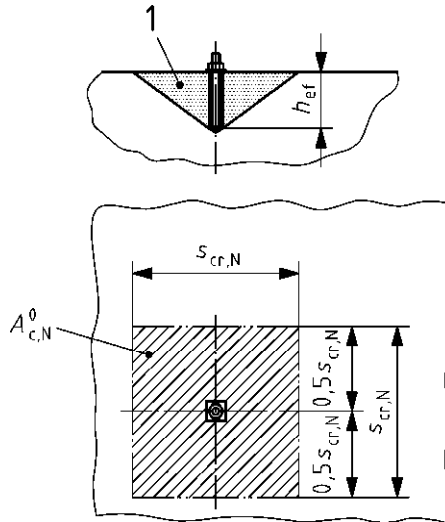
### 6.2.3.5 Effect of the eccentricity of the load

The factor  $\psi_{ec,N}$  takes account of a group effect when different tension loads are acting on the individual fasteners of a group.

$$\psi_{ec,N} = \frac{1}{1 + 2 \cdot e_N / s_{cr,N}} \leq 1 \quad [-] \quad (18)$$

with:  $e_N$ : eccentricity of the resulting tensile load acting on the tensioned fasteners (CEN/TS 1992-4-1:2009, clause 5.2).

Where there is an eccentricity in two directions,  $\psi_{ec,N}$  shall be determined separately for each direction and the product of both factors shall be inserted in Equation (12).

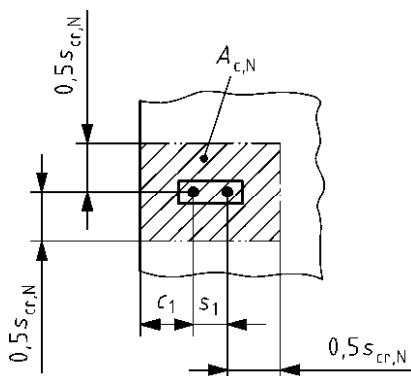


a)

$$A_{c,N} = (c_1 + 0,5 s_{cr,N}) \cdot s_{cr,N}$$

if:  $c_1 \leq c_{cr,N}$

b)

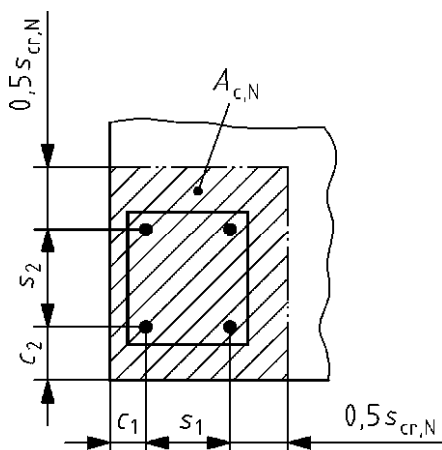


$$A_{c,N} = (c_1 + s_1 + 0,5 s_{cr,N}) \cdot s_{cr,N}$$

if:  $c_1 \leq c_{cr,N}$

$$s_1 \leq s_{cr,N}$$

c)



$$A_{c,N} = (c_1 + s_1 + 0,5 s_{cr,N}) \cdot (c_2 + s_2 + 0,5 s_{cr,N})$$

if:  $c_1; c_2 \leq c_{cr,N}$

$$s_1 ; s_2 \leq s_{cr,N}$$

**Key**

- a) Individual fastener at the edge of a concrete member
- b) Group of two fasteners at the edge of a concrete member
- c) Group of four fasteners at a corner of a concrete member

**Figure 2 — Examples of actual areas  $A_{c,N}$  of the idealised concrete cones for different arrangements of fasteners in case of axial tension load**

**6.2.3.6 Effect of a narrow member**

For the case of fasteners in an application with three or more edges distances less than  $c_{cr,N}$  from the fasteners (see Figure 3) the calculation according to Equation (12) leads to conservative results. More precise results are obtained if in the case of single fasteners the value  $h_{ef}$  is substituted by:

$$h'_{ef} = \frac{c_{max}}{c_{cr,N}} \cdot h_{ef} \quad (19)$$

or in case of groups  $h_{ef}$  is limited to the larger value of

$$h'_{ef} = \frac{c_{max}}{c_{cr,N}} \cdot h_{ef} \quad \text{or} \quad h'_{ef} = \frac{s_{max}}{s_{cr,N}} \cdot h_{ef} \quad (20)$$

where  $c_{max}$  maximum distance from centre of a fastener to the edge of concrete member  $\leq c_{cr,N}$

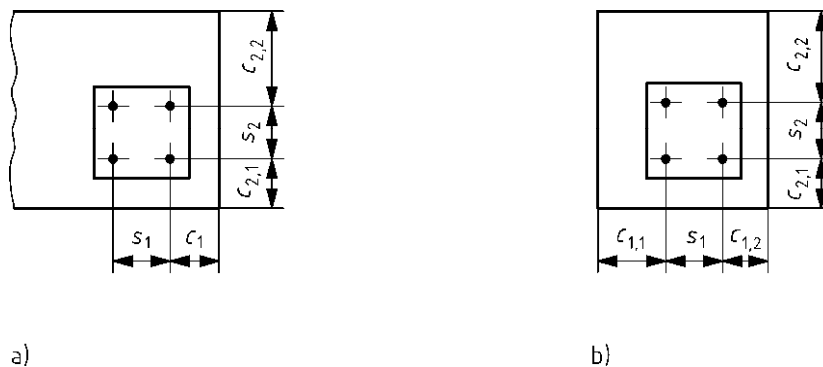
$s_{max}$  maximum centre to centre spacing of fasteners  $\leq s_{cr,N}$

The value  $h'_{ef}$  is inserted in Equation (13) or Equation (14) and used for the determination of  $A_{c,N}^0$  and  $A_{c,N}$  according to Figures 1 and 2 as well as in Equations (15), (16) and (18), where the values

$$s'_{cr,N} = s_{cr,N} \cdot \frac{h'_{ef}}{h_{ef}} \quad (21)$$

$$c'_{cr,N} = c_{cr,N} \cdot \frac{h'_{ef}}{h_{ef}} \quad (22)$$

are inserted for  $s_{cr,N}$  or  $c_{cr,N}$ , respectively.



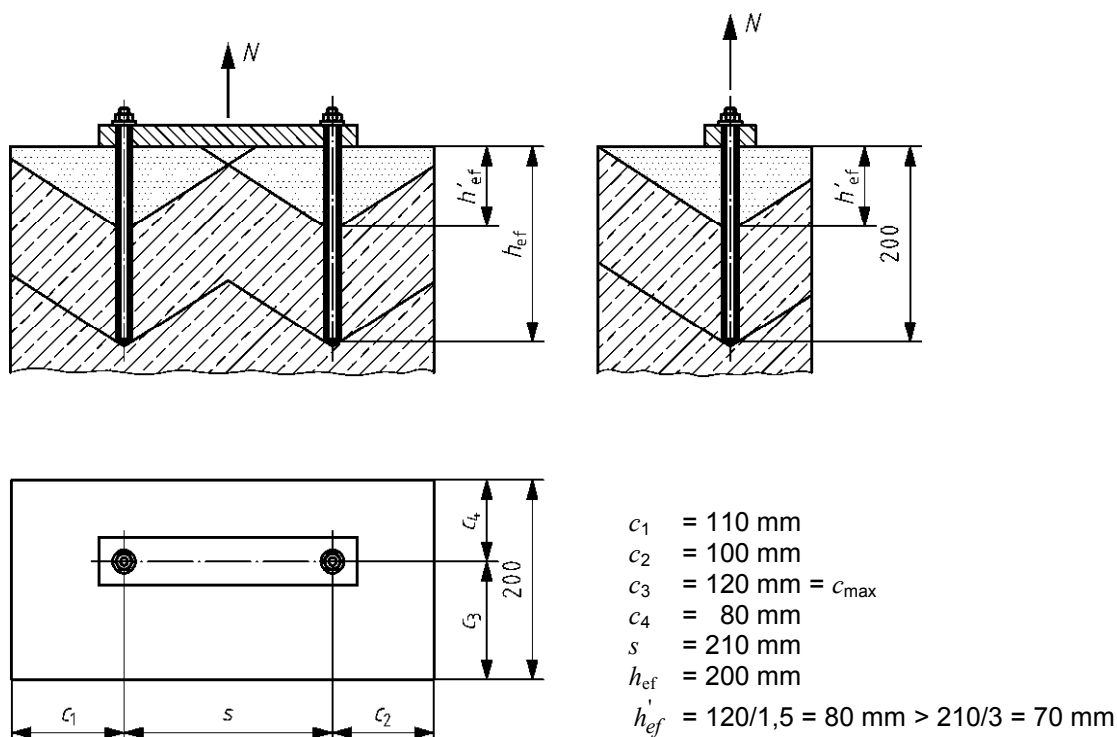
**Key**

a)  $(c_1; c_{2,1}; c_{2,2}) \leq c_{cr,N}$

b)  $(c_{1,1}; c_{1,2}; c_{2,1}; c_{2,2}) \leq c_{cr,N}$

**Figure 3 — Examples for fastenings in concrete members where  $s'_{cr,N}$  and  $c'_{cr,N}$  may be used**

NOTE An example for the calculation of  $h'_{ef}$  is illustrated in Figure 4.



**Figure 4 — Illustration of the calculation of  $h'_{\text{ef}}$  for a double fastening influenced by 4 edges**

## 6.2.4 Splitting failure

### 6.2.4.1 Splitting failure due to fastener installation

Splitting failure is avoided during fastener installation by complying with minimum values for edge distance  $c_{\min}$ , spacing  $s_{\min}$ , member thickness  $h_{\min}$  and requirements on reinforcement as given in the relevant European Technical Specification.

### 6.2.4.2 Splitting failure due to loading

Splitting failure due to loading shall be taken into account according the following rules. The characteristic values of edge distance and spacing in the case of splitting under load,  $c_{\text{cr,sp}}$  and  $s_{\text{cr,sp}}$  are given in the relevant European Technical Specification.

Splitting failure due to loading shall be taken into account according to the following rules:

No verification of splitting failure is required if at least one of the following conditions is fulfilled:

- a) The edge distance in all directions is  $c \geq 1,0 c_{\text{cr,sp}}$  for single fasteners and  $c \geq 1,2 c_{\text{cr,sp}}$  for fastener groups and the member depth is  $h \geq h_{\min}$  in both cases.

The characteristic values of member thickness  $h_{\min}$ , edge distance and spacing in the case of splitting under load,  $c_{\text{cr,sp}}$  and  $s_{\text{cr,sp}}$  are given in the relevant European Technical Specification.

- b) The characteristic resistance for concrete cone failure and pull-out failure is calculated for cracked concrete and reinforcement resists the splitting forces and limits the crack width to  $w_k \leq 0,3 \text{ mm}$ .

If the conditions a) and b) are not fulfilled, then the characteristic resistance of a post-installed fastener or a group of fasteners in case of splitting failure should be calculated according to Equation (23).



$$N_{Rk,sp} = N_{Rk,c}^0 \cdot \frac{A_{c,N}}{A_{c,N}^0} \cdot \psi_{s,N} \cdot \psi_{re,N} \cdot \psi_{ec,N} \cdot \psi_{h,sp} \quad (23)$$

with:

$N_{Rk,c}^0$ ,  $\psi_{s,N}$ ,  $\psi_{re,N}$ ,  $\psi_{ec,N}$  according to 6.2.3, however the values  $c_{cr,N}$  and  $s_{cr,N}$  should be replaced by  $c_{cr,sp}$  and  $s_{cr,sp}$ .  $c_{cr,sp}$  and  $s_{cr,sp}$  are based on a member thickness  $h_{min}$ .

$\psi_{h,sp}$  takes into account the influence of the actual member depth  $h$  on the splitting resistance. For fasteners according to current experience it is given by Equation (24).

$$\psi_{h,sp} = \left( \frac{h}{h_{min}} \right)^{2/3} \leq \left( \frac{2h_{ef}}{h_{min}} \right)^{2/3} \quad (24)$$

NOTE If in the relevant European Technical Specification  $c_{cr,sp}$  for more than one member depth  $h$  is given, then the member depth valid for the used  $c_{cr,sp}$  shall be inserted in Equation (24).

If the edge distance of a fastener is smaller than the value  $c_{cr,sp}$  a longitudinal reinforcement should be provided along the edge of the member.

## 6.3 Shear load

### 6.3.1 Required verifications

The required verifications are given in Table 2:

**Table 2 — Verification for chemical fasteners loaded in shear**

	Single fastener	Fastener groups	
		most loaded fastener	fastener group
<b>Steel failure without lever arm</b>	$V_{Ed} \leq V_{Rd,s} = \frac{V_{Rk,s}}{\gamma_{Ms}}$	$V_{Ed}^h \leq V_{Rd,s} = \frac{V_{Rk,s}}{\gamma_{Ms}}$	
<b>Steel failure with lever arm</b>	$V_{Ed} \leq V_{Rd,s} = \frac{V_{Rk,s}}{\gamma_{Ms}}$	$V_{Ed}^h \leq V_{Rd,s} = \frac{V_{Rk,s}}{\gamma_{Ms}}$	
<b>Concrete edge failure</b>	$V_{Ed} \leq V_{Rd,c} = \frac{V_{Rk,c}}{\gamma_{Mc}}$		$V_{Ed}^g \leq V_{Rd,c} = \frac{V_{Rk,c}}{\gamma_{Mc}}$
<b>Concrete pry-out failure</b>	$V_{Ed} \leq V_{Rd,cp} = \frac{V_{Rk,cp}}{\gamma_{Mc}}$		$V_{Ed}^g \leq V_{Rd,cp} = \frac{V_{Rk,cp}}{\gamma_{Mc}}$

### 6.3.2 Steel failure

#### 6.3.2.1 Shear load without lever arm

For post-installed fasteners the characteristic resistance of a fastener in case of steel failure  $V_{Rk,s}$  is given in the relevant European Technical Specification. The strength calculations are based on  $f_{uk}$ . In case of groups with fasteners with a hole clearance the diameter in the hole of the fixture is not larger than the value  $d_f$  given

in CEN/TS 1992-4-1:2009, Table 1 and made of non-ductile steel, this characteristic shear resistance should be multiplied with the factor  $k_2$ . The factor  $k_2$  is given in the relevant European Technical Specification.

NOTE According to current experience the factor  $k_2$  for non-ductile steel is  $k_2 = 0,8$ .

### 6.3.2.2 Shear load with lever arm

For a fastener not threaded to a steel plate the characteristic resistance in case of steel failure  $V_{Rk,s}$  may be obtained from Equation (25).

$$V_{Rk,s} = \frac{\alpha_M \cdot M_{Rk,s}}{l} \quad [\text{N}] \quad (25)$$

with:  $\alpha_M, l$ : see CEN/TS 1992-4-1:2009, 5.2.3.3

$$M_{Rk,s} = M_{Rk,s}^0 \cdot (1 - N_{Ed} / N_{Rd,s}) \quad (26)$$

$$N_{Rd,s} = N_{Rk,s} / \gamma_{Ms}$$

The characteristic resistance under tension load in case of steel failure,  $N_{Rk,s}$ , the partial safety factor  $\gamma_{Ms}$  and the characteristic bending resistance of a single post-installed fastener,  $M_{Rk,s}^0$ , are given in the relevant European Technical Specification.

### 6.3.3 Concrete pry-out failure

Fastenings may fail due to a concrete pry-out failure at the side opposite to load direction. The corresponding characteristic resistance  $V_{Rk,cp}$  may be calculated from Equation (27). The lowest value of Equation (27) is decisive.

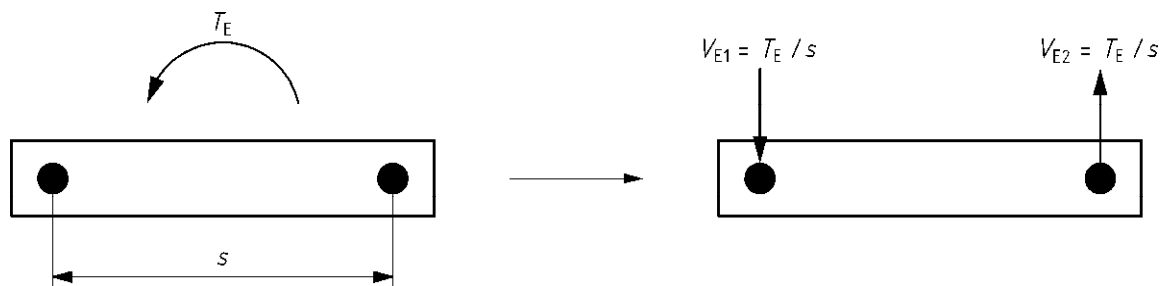
$$V_{Rk,cp} = \min \begin{cases} k_3 \cdot N_{Rk,c} \\ k_3 \cdot N_{Rk,p} \end{cases} \quad (27)$$

with:  $k_3$  factor to be taken from the relevant European Technical Specification

$N_{Rk,p}$  according to 6.2.2 determined for the fasteners loaded in shear

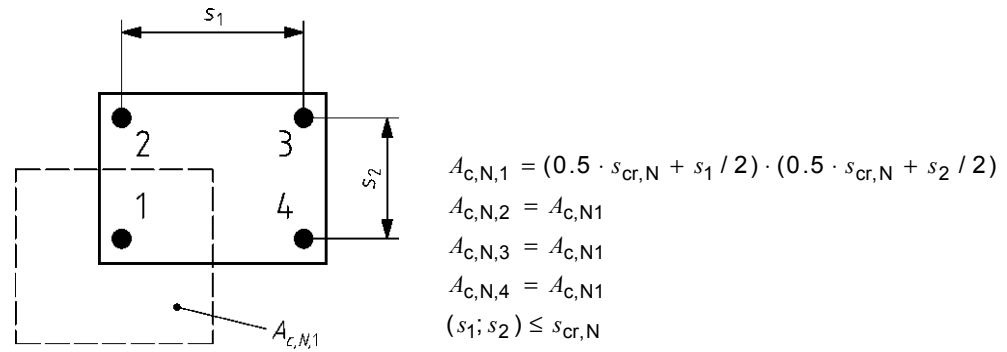
$N_{Rk,c}$  according to 6.2.3 determined for the fasteners loaded in shear

NOTE In cases where a fastener group is loaded by shear loads and/or external torsion moments, the direction of the individual shear loads may alter. In the example of Fig. 5 the shear loads acting on the individual anchors neutralise each other and the shear load acting on the entire group is  $V_{Ed} = 0$ . Then verification of pry-out failure for the entire group according to Equation (27) is substituted by the verification of the most unfavourable anchor.

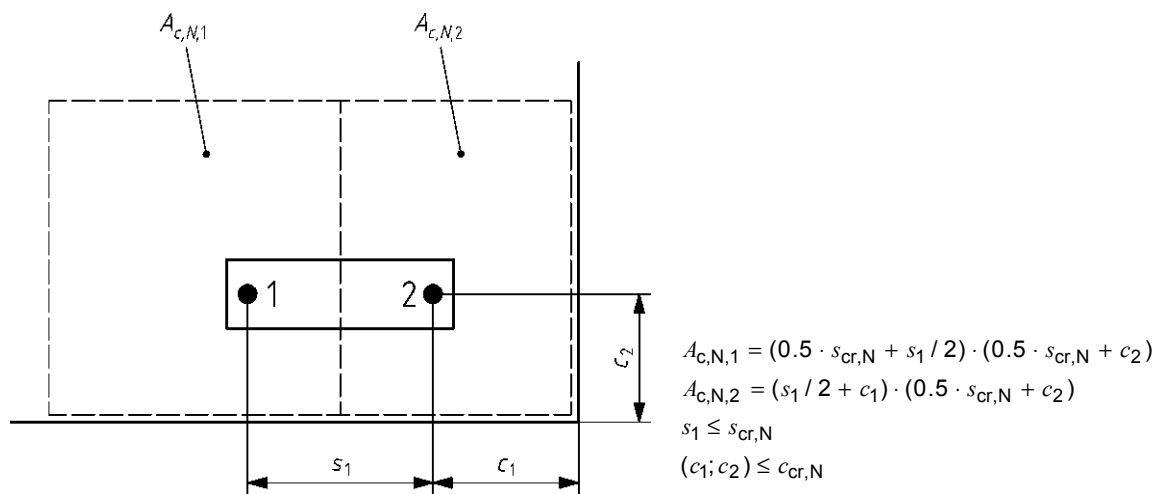


**Figure 5 —Group of two fasteners loaded by a torsion moment; shear loads acting on the individual anchors of the group alter their directions, example**

When calculating the resistance of the most unfavourable anchor the influences of both, edge distances as well as anchor spacing have to be considered. Examples for the calculation of  $A_{c,N}$  are given in Figure 6 and Figure 7.



**Figure 6** —Group of four fasteners without edge influence, if the most unfavourable fastener shall be verified, example for the calculation of the area  $A_{c,N}$



**Figure 7** —Group of two fasteners located in a corner, if the most unfavourable fastener shall be verified, example for the calculation of the area  $A_{c,N}$

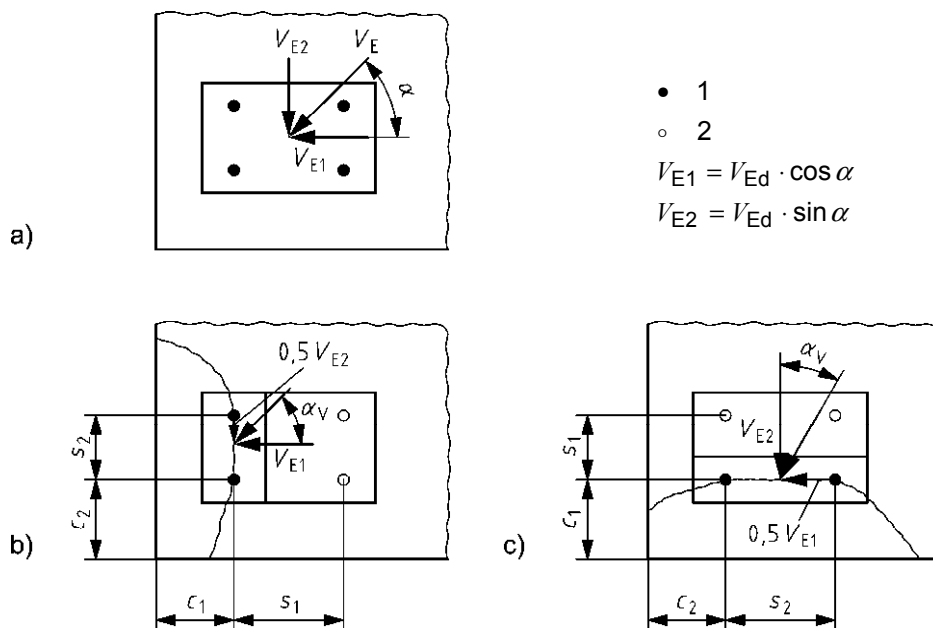
### 6.3.4 Concrete edge failure

#### 6.3.4.1 General

The following conditions shall be observed:

- For single fasteners and groups with not more than 4 fasteners with an edge distance in all directions  $c \geq 10 h_{ef}$  or  $c \geq 60 d$ , a check of the characteristic concrete edge failure resistance may be omitted. The smaller value is decisive.
- For fastenings with more than one edge (see Figure 8), the resistances for all edges shall be calculated. The smallest value is decisive.
- For groups with fasteners arranged perpendicular to the edge and loaded parallel to the edge or by a torsion moment the verification for concrete edge failure is valid for  $s_1 \geq c_1$  or  $c_1 \geq 150$  mm.

**NOTE** In cases of groups with fasteners arranged perpendicular to the edge and loaded parallel to the edge or by a torsion moment where  $s_1 < c_1$  and  $c_1 < 150$  mm the design method for concrete edge failure may yield unconservative results.



**Key**  
 1 loaded fastener  
 2 unloaded fastener  
 a) situation  
 b) verification for the left edge  
 c) verification for the bottom edge

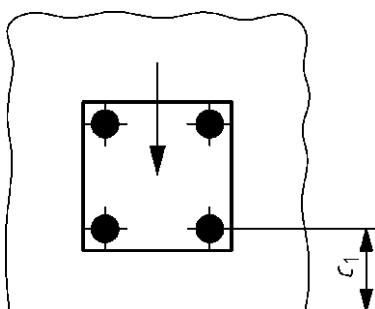
**Figure 8 — Verification for a quadruple fastener with hole clearance at a corner, example**

**6.3.4.2 Characteristic shear resistance  $V_{Rk,c}$**

The characteristic resistance for a fastener or a fastener group (Figure 9) corresponds to:

$$V_{Rk,c} = V_{Rk,c}^0 \cdot \frac{A_{c,V}}{A_{c,V}^0} \cdot \psi_{s,V} \cdot \psi_{h,V} \cdot \psi_{ec,V} \cdot \psi_{\alpha,V} \cdot \psi_{re,V} \quad [N] \quad (28)$$

The different factors of Equation (28) are given below.



**Figure 9 — Fastener group loaded perpendicular to the edge, example**

**6.3.4.2.1 Characteristic resistance of a single fastener**

The initial value of the characteristic resistance of a post-installed fastener loaded perpendicular to the edge in cracked concrete corresponds to:

$$V_{Rk,c}^0 = 1,6 \cdot d_{nom}^\alpha \cdot l_f^\beta \cdot \sqrt{f_{ck,cube}} \cdot c_1^{1,5} \quad [N] \quad (29)$$

with:

$$\alpha = 0,1 \cdot \left( \frac{l_f}{c_1} \right)^{0,5} \quad [-] \quad (30)$$

$$\beta = 0,1 \cdot \left( \frac{d_{nom}}{c_1} \right)^{0,2} \quad [-] \quad (31)$$

$f_{ck,cube}$  characteristic cube strength of the concrete strength class but noting the limitations given in the relevant European Technical Specification, [N/mm<sup>2</sup>]

$c_1$  edge distance in the direction of the shear load, [mm]

$l_f$  =  $h_{ef}$  in case of a uniform diameter of the shank of the headed fastener, [mm]  
 $\leq 8 d_{nom}$

$d_{nom} \leq 60$  mm

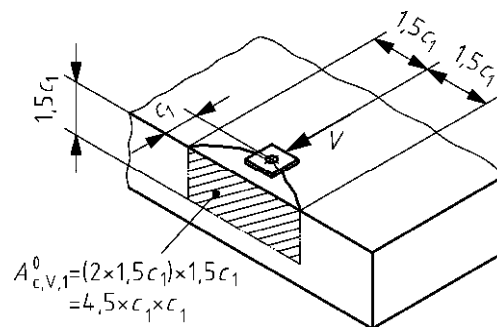
The values  $d_{nom}$  and  $l_f$  are given in the relevant European Technical Specification.

#### 6.3.4.2.2 Geometric effect of axial spacing, edge distance and member thickness

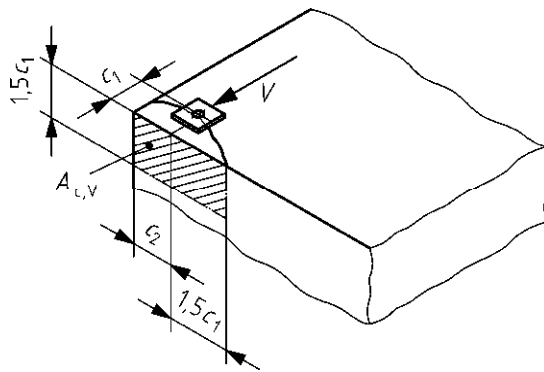
The geometrical effect of spacing as well as of further edge distances and the effect of thickness of the concrete member on the characteristic resistance is taken into account by the ratio  $A_{c,V} / A_{c,V}^0$ , where:

$$\begin{aligned} A_{c,V}^0 &= \text{reference projected area, see Figure 10} \\ &= 4,5 c_1^2 \end{aligned} \quad (32)$$

$A_{c,V}$  area of the idealized concrete break-out, limited by the overlapping concrete cones of adjacent fasteners ( $s \leq 3 c_1$ ) as well as by edges parallel to the assumed loading direction ( $c_2 \leq 1,5 c_1$ ) and by member thickness ( $h \leq 1,5 c_1$ ). Examples for calculation of  $A_{c,V}$  are given in Figure 11.



**Figure 10** — Idealized concrete break-out body and area  $A_{c,V}^0$  for a single fastener

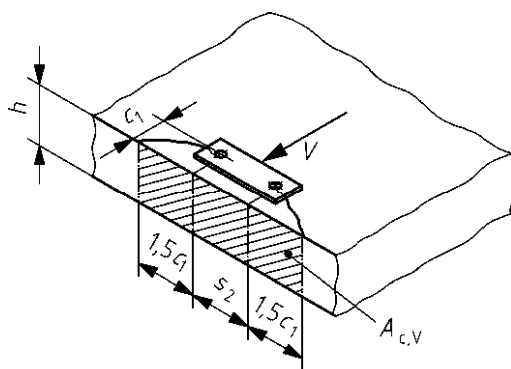


a)

$$A_{c,v} = 1,5 c_1 (1,5 c_1 + c_2)$$

$$h \geq 1,5 c_1$$

$$c_2 \leq 1,5 c_1$$

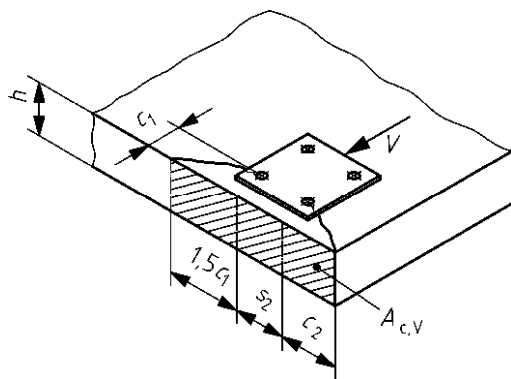


b)

$$A_{c,v} = (2 \cdot 1,5 c_1 + s_2) \cdot h$$

$$h < 1,5 c_1$$

$$s_2 \leq 3 c_1$$



c)

$$A_{c,v} = (1,5 c_1 + s_2 + c_2) \cdot h$$

$$h < 1,5 c_1$$

$$s_2 \leq 3 c_1$$

$$c_2 \leq 1,5 c_1$$

**Key**

- a) single anchor at a corner
- b) group of anchors at an edge in a thin concrete member
- c) group of anchors at a corner in a thin concrete member

**Figure 11 — Examples of actual projected areas  $A_{c,v}$  of the idealized concrete break-out bodies for different fastener arrangements under shear loading**

### 6.3.4.2.3 Effect of the disturbance of the distribution of stresses in the concrete due to further edges

The factor  $\psi_{s,V}$  takes account of the disturbance of the distribution of stresses in the concrete due to further edges of the concrete member on the shear resistance. For fastenings with two edges parallel to the direction of loading (e.g. in a narrow concrete member) the smaller edge distance should be inserted in Equation (33).

$$\psi_{s,V} = 0,7 + 0,3 \cdot \frac{c_2}{1,5 c_1} \leq 1 \quad (33)$$

### 6.3.4.2.4 Effect of the thickness of the structural component

The factor  $\psi_{h,V}$  takes account of the fact that the concrete edge resistance does not decrease proportionally to the member thickness as assumed by the ratio  $A_{c,V}/A_{c,V}^0$  (Figures 11b) and 11c)).

$$\psi_{h,V} = \left( \frac{1,5 c_1}{h} \right)^{0,5} \geq 1 \quad (34)$$

### 6.3.4.2.5 Effect of the eccentricity of the load

The factor  $\psi_{ec,V}$  takes account into a group effect when different shear loads are acting on the individual fasteners of a group (see Figure 12).

$$\psi_{ec,V} = \frac{1}{1 + 2 \cdot e_V / (3 \cdot c_1)} \leq 1 \quad (35)$$

$e_V$  eccentricity of the resulting shear load acting on the fasteners relative to the centre of gravity of the fasteners loaded in shear

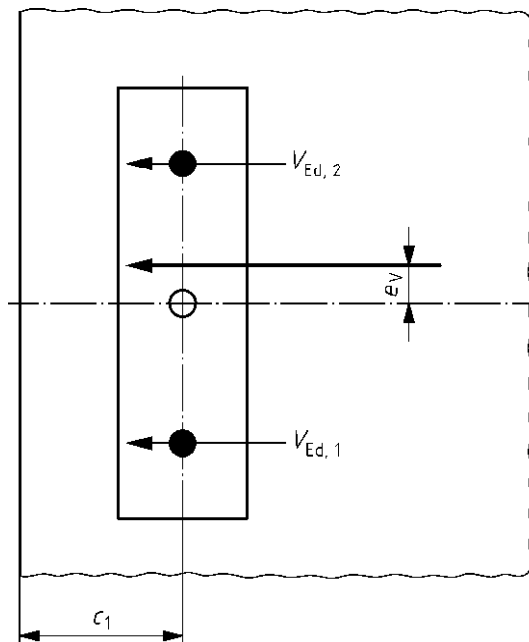


Figure 12 — Resolving unequal shear components into an eccentric shear load resultant, example

#### 6.3.4.2.6 Effect of load direction

The factor  $\psi_{\alpha,V}$  takes into account the angle  $\alpha_V$  between the load applied  $V_{Sd}$  and the direction perpendicular to the free edge under consideration for the calculation of the concrete edge resistance (see Figure 8).

$$\psi_{\alpha,V} = \sqrt{\frac{1}{(\cos \alpha_V)^2 + (0,4 \cdot \sin \alpha_V)^2}} \geq 1 \quad (36)$$

$\alpha_V$  = angle between design shear load  $V_{Sd}$  and a line perpendicular to the edge, see Figure 8.

#### 6.3.4.2.7 Effect of the position of the fastening

The factor  $\psi_{re,V}$  takes account of the effect of the position of the fastening in cracked or non-cracked concrete or of the type of reinforcement on the edge.

$\psi_{re,V} = 1,0$  fastening in cracked concrete without edge reinforcement or stirrups

$\psi_{re,V} = 1,2$  fastening in cracked concrete with straight edge reinforcement ( $\geq \emptyset 12$  mm)

$\psi_{re,V} = 1,4$  fastening in cracked concrete with edge reinforcement and closely spaced stirrups or wire mesh with a spacing  $a \leq 100$  mm and  $a \leq 2 c_1$ , or  
fastening in non-cracked concrete (verification according to Part 1, Section 5)

A factor  $\psi_{re,V} > 1$  for applications in cracked concrete should only be applied, if the embedment depth  $h_{ef}$  of the fastener is  $h_{ef} \geq 2,5$  times the concrete cover of the edge reinforcement.

#### 6.3.4.2.8 Effect of a narrow thin member

For fastenings in a narrow, thin member with  $c_{2,max} \leq 1,5 c_1$  and  $h \leq 1,5 c_1$  (see Figure 13) the calculation according to Equation (28) leads to conservative results. More precise results are achieved if  $c_1$  is limited in case of single fasteners to the larger value of

$$c_1' = \max \begin{cases} c_{2,max} / 1,5 \\ h / 1,5 \end{cases} \quad (37)$$

with

$c_{2,max}$  = largest of the two edge distances parallel to the direction of loading

or in case of groups  $c_1$  is limited to the largest value of

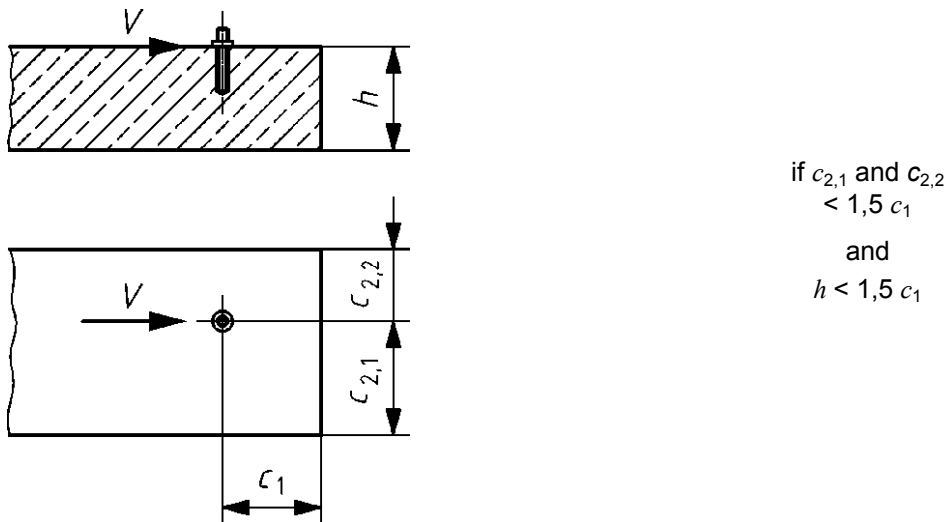
$$c_1' = \max \begin{cases} c_{2,max} / 1,5 \\ h / 1,5 \\ s_{max} / 3 \end{cases} \quad (38)$$

with

$s_{max}$  = maximum spacing between fasteners within the group

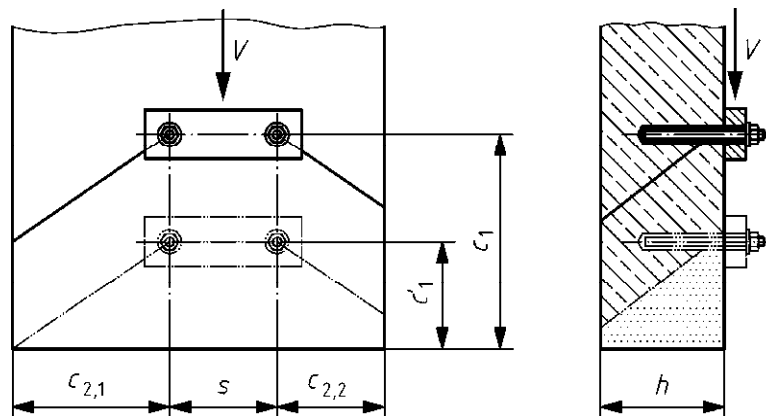
The value  $c_1'$  is inserted in Equations (29) to (35) as well as in the determination of the areas  $A_{c,V}^0$  and  $A_{c,V}$  according to Figures 10 and 11.





**Figure 13 — Example for a fastening in a thin, narrow member where the value  $c_1'$  may be used**

NOTE An example for the calculation of  $c_1'$  is illustrated in Figure 14.



$s = 100 \text{ mm}$   $c_1 = 200 \text{ mm}$ ,  $h = 120 \text{ mm} < 1,5 \cdot 200 \text{ mm}$ ,  
 $c_{2,1} = 150 \text{ mm} \leq 1,5 \cdot 200 \text{ mm}$ ,  $c_{2,2} = 100 \text{ mm} < 1,5 \cdot 200 \text{ mm}$ ,  $c_1' = 150/1,5 = 100 \text{ mm}$

**Figure 14 — Illustration of the calculation of the value  $c_1'$ , example**

## 6.4 Combined tension and shear load

### 6.4.1 Steel failure decisive for tension and shear load

For combined tension and shear loads the following equations should be satisfied:

$$\beta_N^2 + \beta_V^2 \leq 1 \quad (39)$$

where

$$\beta_N = N_{Ed}/N_{Rd} \leq 1 \quad \text{and} \quad \beta_V = V_{Ed}/V_{Rd} \leq 1$$

### 6.4.2 Other modes of failure decisive

For combined tension and shear loads either of the following Equations (40) (see Figure 15) or Equation (41) should be satisfied:

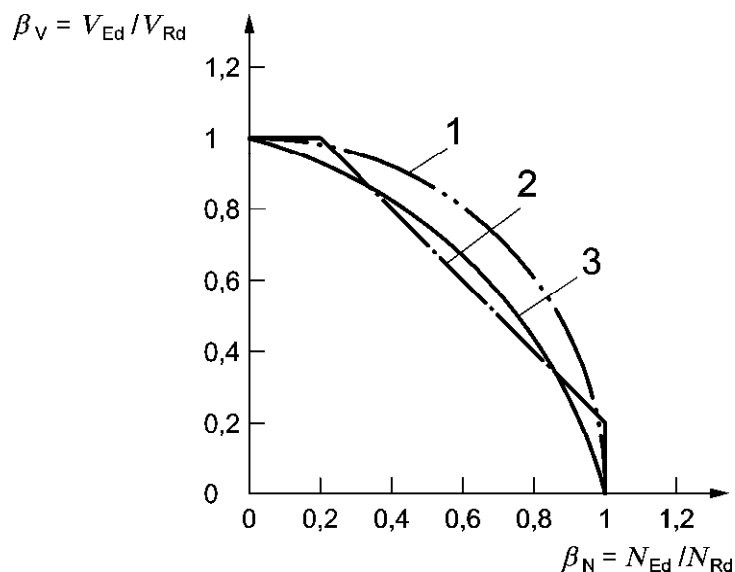
$$\beta_N + \beta_V \leq 1,2 \tag{40}$$

$$\beta_N^{1,5} + \beta_V^{1,5} \leq 1 \tag{41}$$

where

$$\beta_N = N_{Ed}/N_{Rd} \leq 1 \text{ and } \beta_V = V_{Ed}/V_{Rd} \leq 1$$

In Equations (40) and (41) the largest value of  $\beta_N$  and  $\beta_V$  for the different failure modes should be taken.



#### Key

- 1) according to equation (39)
- 2) according to equation (40)
- 3) according to equation (41)

**Figure 15 — Interaction diagram for combined tension and shear loads**

## 7 Fatigue

See CEN/TS 1992-4-1.

## 8 Seismic

See CEN/TS 1992-4-1.



---

## BSI - British Standards Institution

BSI is the independent national body responsible for preparing British Standards. It presents the UK view on standards in Europe and at the international level. It is incorporated by Royal Charter.

### Revisions

British Standards are updated by amendment or revision. Users of British Standards should make sure that they possess the latest amendments or editions.

It is the constant aim of BSI to improve the quality of our products and services. We would be grateful if anyone finding an inaccuracy or ambiguity while using this British Standard would inform the Secretary of the technical committee responsible, the identity of which can be found on the inside front cover. Tel: +44 (0)20 8996 9000. Fax: +44 (0)20 8996 7400.

BSI offers members an individual updating service called PLUS which ensures that subscribers automatically receive the latest editions of standards.

### Buying standards

Orders for all BSI, international and foreign standards publications should be addressed to Customer Services. Tel: +44 (0)20 8996 9001. Fax: +44 (0)20 8996 7001 Email: [orders@bsigroup.com](mailto:orders@bsigroup.com) You may also buy directly using a debit/credit card from the BSI Shop on the Website <http://www.bsigroup.com/shop>

In response to orders for international standards, it is BSI policy to supply the BSI implementation of those that have been published as British Standards, unless otherwise requested.

### Information on standards

BSI provides a wide range of information on national, European and international standards through its Library and its Technical Help to Exporters Service. Various BSI electronic information services are also available which give details on all its products and services. Contact Information Centre. Tel: +44 (0)20 8996 7111 Fax: +44 (0)20 8996 7048 Email: [info@bsigroup.com](mailto:info@bsigroup.com)

Subscribing members of BSI are kept up to date with standards developments and receive substantial discounts on the purchase price of standards. For details of these and other benefits contact Membership Administration. Tel: +44 (0)20 8996 7002 Fax: +44 (0)20 8996 7001 Email: [membership@bsigroup.com](mailto:membership@bsigroup.com)

Information regarding online access to British Standards via British Standards Online can be found at <http://www.bsigroup.com/BSOL>

Further information about BSI is available on the BSI website at <http://www.bsigroup.com>.

### Copyright

Copyright subsists in all BSI publications. BSI also holds the copyright, in the UK, of the publications of the international standardization bodies. Except as permitted under the Copyright, Designs and Patents Act 1988 no extract may be reproduced, stored in a retrieval system or transmitted in any form or by any means – electronic, photocopying, recording or otherwise – without prior written permission from BSI.

This does not preclude the free use, in the course of implementing the standard, of necessary details such as symbols, and size, type or grade designations. If these details are to be used for any other purpose than implementation then the prior written permission of BSI must be obtained.

Details and advice can be obtained from the Copyright and Licensing Manager. Tel: +44 (0)20 8996 7070 Email: [copyright@bsigroup.com](mailto:copyright@bsigroup.com)