

Geotechnical investigation and testing — Field testing —

Part 11: Flat dilatometer test

ICS 93.020

National foreword

This Draft for Development reproduces verbatim CEN ISO/TS 22476-11:2005.

This publication is not to be regarded as a British Standard.

It is being issued in the Draft for Development series of publications and is of a provisional nature because the new edition of the international document has been issued as a Technical Specification. It should be applied on this provisional basis, so that information and experience of its practical application may be obtained.

Comments arising from the use of this Draft for Development are requested so that UK experience can be reported to the international organization responsible for the Technical Specification. A review of this publication will be initiated not later than 3 years after its publication by the international organization so that a decision can be taken on its status at the end of its 3-year life. Notification of the start of the review period will be made in an announcement in the appropriate issue of *Update Standards*.

According to the replies received by the end of the review period, the responsible BSI Committee will decide whether to support the conversion into an international standard, to extend the life of the Technical Specification for another 3 years or to withdraw it. Comments should be sent in writing to the Secretary of BSI Subcommittee B/526/3, Site investigation and ground testing, at British Standards House, 389 Chiswick High Road, London W4 4AL, giving the document reference and clause number and proposing, where possible, an appropriate revision of the text.

A list of organizations represented on this subcommittee can be obtained on request to its secretary.

Cross-references

The British Standards which implement international publications referred to in this document may be found in the *BSI Catalogue* under the section entitled "International Standards Correspondence Index", or by using the "Search" facility of the *BSI Electronic Catalogue* or of British Standards Online.

This publication does not purport to include all the necessary provisions of a contract. Users are responsible for its correct application.

Summary of pages

This document comprises a front cover, an inside front cover, the CEN ISO/TS title page, the CEN ISO/TS foreword page, the ISO/TS title page, pages ii to vi, pages 1 to 9 and a back cover.

The BSI copyright notice displayed in this document indicates when the document was last issued.

Amendments issued since publication

Amd. No.	Date	Comments

This Draft for Development was published under the authority of the Standards Policy and Strategy Committee on 31 May 2006

© BSI 2006

ISBN 0 580 48402 5

ICS 93.020

English version

**Geotechnical investigation and testing - Field testing - Part 11:
Flat dilatometer test (ISO 22476-11:2005)**

Reconnaissance et essais géotechniques - Essais en place
- Partie 11: Essai au dilatomètre plat (ISO 22476-11:2005)

Geotechnische Erkundung und Untersuchung -
Felduntersuchungen - Teil 11: Flachdilatometerversuch
(ISO 22476-11:2005)

This Technical Specification (CEN/TS) was approved by CEN on 23 August 2004 for provisional application.

The period of validity of this CEN/TS is limited initially to three years. After two years the members of CEN will be requested to submit their comments, particularly on the question whether the CEN/TS can be converted into a European Standard.

CEN members are required to announce the existence of this CEN/TS in the same way as for an EN and to make the CEN/TS available promptly at national level in an appropriate form. It is permissible to keep conflicting national standards in force (in parallel to the CEN/TS) until the final decision about the possible conversion of the CEN/TS into an EN is reached.

CEN members are the national standards bodies of Austria, Belgium, Cyprus, Czech Republic, Denmark, Estonia, Finland, France, Germany, Greece, Hungary, Iceland, Ireland, Italy, Latvia, Lithuania, Luxembourg, Malta, Netherlands, Norway, Poland, Portugal, Slovakia, Slovenia, Spain, Sweden, Switzerland and United Kingdom.



EUROPEAN COMMITTEE FOR STANDARDIZATION
COMITÉ EUROPÉEN DE NORMALISATION
EUROPÄISCHES KOMITEE FÜR NORMUNG

Management Centre: rue de Stassart, 36 B-1050 Brussels

Foreword

This document (CEN ISO/TS 22476-11:2005) has been prepared by Technical Committee CEN/TC 341 "Geotechnical Investigation and Testing", the secretariat of which is held by DIN, in collaboration with Technical Committee ISO/TC 182 "Geotechnics".

According to the CEN/CENELEC Internal Regulations, the national standards organizations of the following countries are bound to announce this CEN Technical Specification: Austria, Belgium, Cyprus, Czech Republic, Denmark, Estonia, Finland, France, Germany, Greece, Hungary, Iceland, Ireland, Italy, Latvia, Lithuania, Luxembourg, Malta, Netherlands, Norway, Poland, Portugal, Slovakia, Slovenia, Spain, Sweden, Switzerland and United Kingdom.

TECHNICAL
SPECIFICATION

ISO/TS
22476-11

First edition
2005-05-15

**Geotechnical investigation and testing —
Field testing —**

**Part 11:
Flat dilatometer test**

*Reconnaissance et essais géotechniques — Essais en place —
Partie 11: Essai au dilatomètre plat*



Reference number
ISO/TS 22476-11:2005(E)

Foreword

ISO (the International Organization for Standardization) is a worldwide federation of national standards bodies (ISO member bodies). The work of preparing International Standards is normally carried out through ISO technical committees. Each member body interested in a subject for which a technical committee has been established has the right to be represented on that committee. International organizations, governmental and non-governmental, in liaison with ISO, also take part in the work. ISO collaborates closely with the International Electrotechnical Commission (IEC) on all matters of electrotechnical standardization.

International Standards are drafted in accordance with the rules given in the ISO/IEC Directives, Part 2.

The main task of technical committees is to prepare International Standards. Draft International Standards adopted by the technical committees are circulated to the member bodies for voting. Publication as an International Standard requires approval by at least 75 % of the member bodies casting a vote.

In other circumstances, particularly when there is an urgent market requirement for such documents, a technical committee may decide to publish other types of normative document:

- an ISO Publicly Available Specification (ISO/PAS) represents an agreement between technical experts in an ISO working group and is accepted for publication if it is approved by more than 50 % of the members of the parent committee casting a vote;
- an ISO Technical Specification (ISO/TS) represents an agreement between the members of a technical committee and is accepted for publication if it is approved by 2/3 of the members of the committee casting a vote.

An ISO/PAS or ISO/TS is reviewed after three years in order to decide whether it will be confirmed for a further three years, revised to become an International Standard, or withdrawn. If the ISO/PAS or ISO/TS is confirmed, it is reviewed again after a further three years, at which time it must either be transformed into an International Standard or be withdrawn.

Attention is drawn to the possibility that some of the elements of this document may be the subject of patent rights. ISO shall not be held responsible for identifying any or all such patent rights.

ISO/TS 22476-11 was prepared by Technical Committee ISO/TC 182, *Geotechnics*, Subcommittee SC 1, *Geotechnical investigation and testing*.

ISO/TS 22476 consists of the following parts, under the general title *Geotechnical investigation and testing* — *Field testing*:

- *Part 1: Electrical cone and piezocone penetration tests*
- *Part 2: Dynamic probing*
- *Part 3: Standard penetration test*
- *Part 4: Ménard pressuremeter test*
- *Part 5: Flexible dilatometer test*
- *Part 6: Self-boring pressuremeter test*
- *Part 7: Borehole jack test*
- *Part 8: Full displacement pressuremeter test*
- *Part 9: Field vane test*
- *Part 10: Weight sounding test*
- *Part 11: Flat dilatometer test*
- *Part 12: Mechanical cone penetration test*
- *Part 13: Plate loading test*

Contents	Page
Foreword	v
Introduction.....	vi
1 Scope	1
2 Normative references.....	1
3 Terms and definitions	1
4 Equipment	3
4.1 Dilatometer equipment	3
4.2 Insertion apparatus	5
5 Test procedure.....	5
5.1 Calibration and checks	5
5.2 Membrane calibration procedure.....	6
5.3 Performing the test.....	6
6 Test results	7
7 Report	7
7.1 Field report.....	7
7.2 Test report.....	7
Bibliography.....	9

Foreword

This document CEN ISO/TS 22476-11:2004 has been prepared by Technical Committee CEN/TC 341 "Geotechnical investigation and testing", the secretariat of which is held by DIN, in collaboration with Technical Committee ISO/TC 182 "Geotechnics".

According to the CEN/CENELEC Internal Regulations, the national standards organizations of the following countries are bound to announce this Technical Specification: Austria, Belgium, Czech Republic, Denmark, Finland, France, Germany, Greece, Hungary Iceland, Ireland, Italy, Luxembourg, Malta, Netherlands, Norway, Portugal, Slovakia, Spain, Sweden, Switzerland and the United Kingdom.

EN ISO 22476 *Geotechnical investigation and testing - Field testing* has the following parts:

- Part 1: Electrical cone and piezocone penetration tests
- Part 2: Dynamic probing
- Part 3: Standard penetration test
- Part 4: Ménard pressuremeter test
- Part 5: Flexible dilatometer test
- Part 6: Self-boring pressuremeter test (TS)¹⁾
- Part 7: Borehole jack test
- Part 8: Full displacement pressuremeter test (TS)¹⁾
- Part 9: Field vane test
- Part 10: Weight sounding test (TS)¹⁾
- Part 11: Flat dilatometer test (TS)¹⁾
- Part 12: Mechanical cone penetration test
- Part 13: Plate loading test.

1) TS Technical Specification.

Introduction

The flat dilatometer test covers the determination of the in situ strength and deformation properties of fine grained soils using a blade shaped probe having a thin circular steel membrane mounted flush on one face.

Results of flat dilatometer tests are mostly to obtain information on soil stratigraphy, in situ state of stress, deformation properties and shear strength.

The basis of the test consists of inserting vertically into the soil a blade-shaped steel probe with a thin expandable circular steel membrane mounted flush on one face and determining, at selected depths or in a semi-continuous manner, the contact pressure exerted by the soil against the membrane when the membrane is flush with the blade and subsequently the pressure exerted when the central displacement of the membrane reaches 1,10 mm.

The flat dilatometer test is most appropriate in clays, silts and sands where particles are small compared to the size of the membrane.

1 Scope

This Technical Specification comprises requirements for ground investigations by means of the flat dilatometer test (DMT) as part of the geotechnical investigation services according to prEN 1997-1 and prEN 1997-2.

2 Normative references

Not applicable.

3 Terms and definitions

For the purposes of this Technical Specification, the following terms and definitions apply

3.1

dilatometer blade (dilatometer probe)

blade –shaped steel probe that is inserted into the soil to run a flat dilatometer test

3.2

membrane

circular steel membrane that is mounted flush on one face of the blade and is expanded when applying a gas pressure at its back

3.3

switch mechanism

apparatus housed inside the blade, behind the membrane, capable of activating and disconnecting an electric contact which in turn sets on and off an audio and/or visual signal when the membrane expands and reaches two preset deflections equal to 0,05 mm and 1,10 mm respectively

3.4

pneumatic-electric cable

cable that connects the control unit to the blade, delivers gas pressure at the back of the membrane, and provides electric continuity between the control unit and the switch mechanism

3.5

control and calibration unit

set of suitable devices capable of supplying gas pressure to the back of the membrane and measuring the pressure when the switch mechanism activates and disconnects the electric contact behind the membrane

3.6

earth wire

wire connecting the control unit to the earth

3.7

pressure source

pressurized gas tank filled with any dry nonflammable and noncorrosive gas

3.8

membrane calibration

procedure to determine the membrane calibration pressure equal to the suction and the pressure that is applied in air to the back of the membrane to retract its centre to 0,05 mm expansion or to expand it to 1,10 mm respectively

**3.9
dilatometer profiling**
execution of a sequence of dilatometer tests from the same station at ground level along a vertical direction at closely spaced intervals with depth increments ranging between 150 mm and 300 mm

**3.10
A-pressure**
pressure (P_A) that is applied to the back of the membrane to expand its centre 0,05 mm in soil

**3.11
B-pressure**
pressure (P_B) that is applied to the back of the membrane to expand its centre 1,10 mm in soil

**3.12
A-membrane-calibration-pressure**
suction, (Δp_A) recorded as a positive value, that must be applied to the back of the membrane to retract its centre to the 0,05 mm deflection in air

**3.13
B-membrane-calibration-pressure**
pressure (Δp_B) that must be applied to the back of the membrane to expand its centre to the 1,10 mm deflection in air

**3.14
 $\Delta p_{A; avg}$ and $\Delta p_{B; avg}$**
averaged values of the membrane calibration pressure obtained from the respective values of ΔP_A and ΔP_B measured before and after each dilatometer profiling or single dilatometer test

**3.15
 Z_m - pressure**
gauge pressure deviation from zero when venting the blade to atmospheric pressure

**3.16
soil pressure**
 p_0
soil pressure against the membrane when it is flush with the blade (e.g. at zero expansion), see Figure 1

NOTE The term "contact pressure" is also used.

**3.17
soil pressure**
 p_1
soil pressure against the membrane when its centre is expanded 1,10 mm (see Figure 1)

**3.18
in situ pore water pressure prior to blade insertion**
 u_0
in situ pore water pressure prior to blade insertion at the elevation of the centre of the membrane

**3.19
in situ effective vertical stress**
 σ'_{v0}
vertical stress prior to blade insertion at the elevation of the centre of the membrane

**3.20
dilatometer material index**
 I_{DMT}
index related to the type of soil

3.21**dilatometer horizontal stress index** K_{DMT}

index related to the situ horizontal stress

3.22**dilatometer modulus** E_{DMT}

parameter related from theory to the modulus of elasticity of the soil

4 Equipment**4.1 Dilatometer equipment**

The equipment shall comprise of the following items:

- dilatometer blade with suitable threader adaptor to connect to push rods;
- pneumatic-electrical cable;
- earth wire;
- control and calibration unit;
- pressure source.

The dimensions of the blade, of the apex angle of the penetrating edge and of the membrane shall be within the limits shown in Figure 1.

Dimensions in millimetres

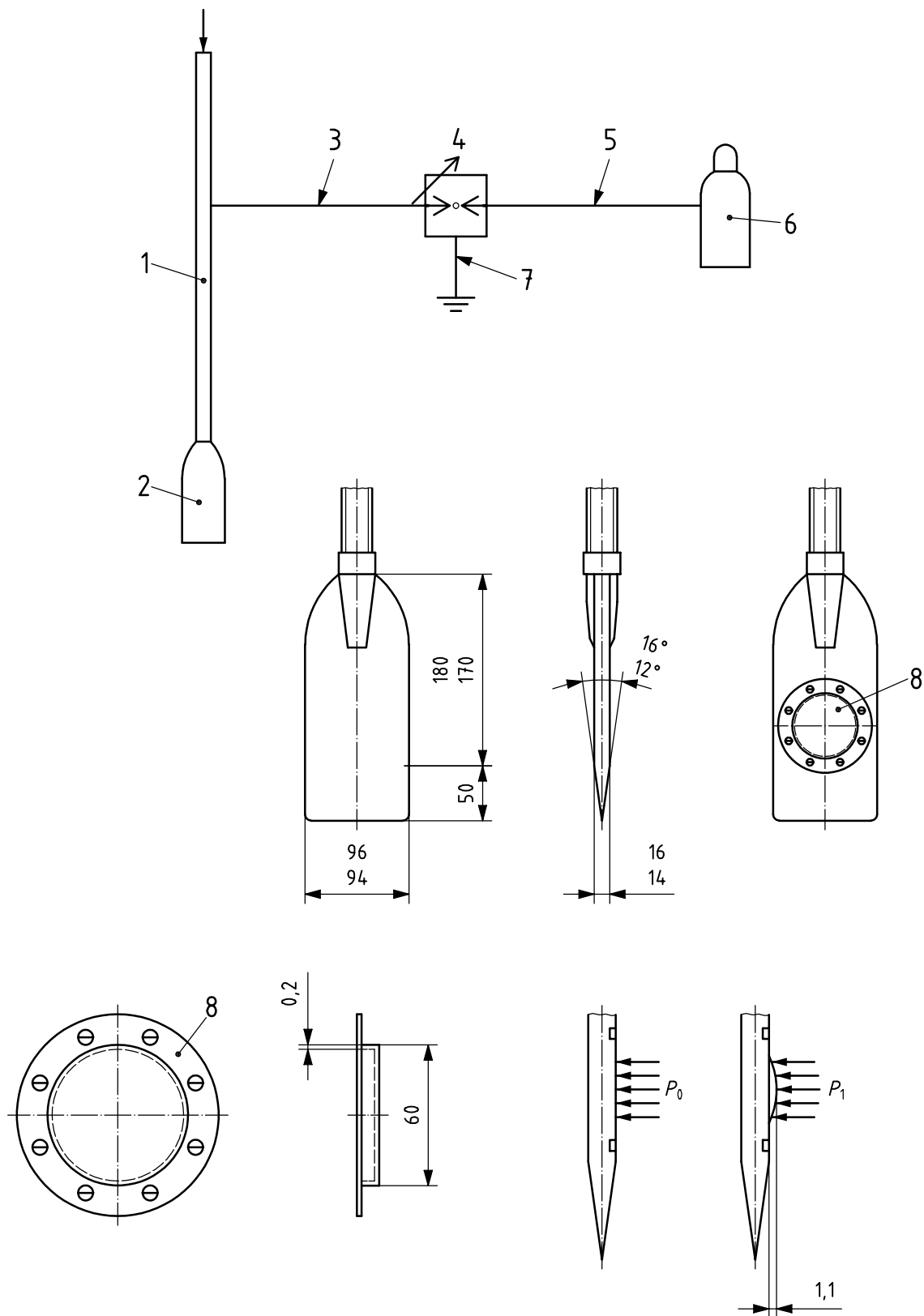

Key

- | | | |
|----------------------------|--------------------------------------|----------------|
| 1 push rods | 4 control and calibration cable unit | 7 ground cable |
| 2 blade | 5 pressure tube | 8 membrane |
| 3 pneumatic electric cable | 6 pressure source | |

Figure 1 — Dilatometer equipment and definition of calculated in situ soil pressure (all measures in mm)

The pneumatic-electrical cable, which provides pneumatic and electrical continuity between the control unit and the dilatometer blade, shall have stainless steel connectors with wire insulators to prevent short circuit and washers to prevent gas leakage.

The control and calibration unit shall accomplish the following:

- it shall be earthed;
- it shall control the rate of gas flow while monitoring and measuring the pressure of gas transmitted from the control unit to the blade and the membrane;
- it shall signal the instants when the electric switch changes from on to off and vice versa.

The pressure measurement devices of the control and calibration unit shall allow to determine the pressure applied to the membrane with intervals of 10 kPa and a reproducibility of 2,5 kPa at least for pressures lower than 500 kPa.

The pressure source shall be provided with a suitable regulator, valves and pressure tubing to connect to the control unit.

4.2 Insertion apparatus

The equipment for inserting the dilatometer blade shall comprise:

- thrust machine to insert and advance the dilatometer blade into the soil;
- push rods with suitable adaptor to connect to the blade;
- hollow slotted adaptors for lateral exit of the pneumatic-electrical cable.

The thrust machine shall be capable of advancing the blade vertically with no significant horizontal or torsional forces.

Penetration rates in the range of 10 mm/s to 30 mm/s should be applied. Driving should be avoided except when advancing the blade through stiff or strongly cemented layers which cannot be penetrated by static push.

Push rods shall be straight and resistant against buckling.

5 Test procedure

5.1 Calibration and checks

All the control, connecting and measuring devices shall be periodically checked and calibrated against a suitable reference instrument to assure that they provide reliable and accurate measurements.

The dilatometer blade and membrane shall be checked before penetrating in the soil. The blade shall be mounted axially with the rods. It shall be planar and coaxial and have a sharp penetration edge. The membrane shall be clean of soil particles, free of any deep scratches, wrinkles or dimples and expand smoothly in air upon pressurization.

The maximum out of plane deviation of the blade, defined as the maximum clearance under a 150 mm long straight edge placed along the blade parallel to its axis, shall not exceed 0,5 mm; the maximum coaxiality error of the blade, defined as the deviation of the penetration edge from the axis of the rods to which the blade is attached, shall not exceed 1,5 mm.

The control unit and the tubing shall be checked for leaks before starting a sequence of dilatometer profilings by plugging the blade end of the pneumatic-electrical cable and checking for any pressure drop in the system. Leakage in excess of 100 kPa/min shall be considered unacceptable and shall be repaired before testing begins.

With the dilatometer equipment assembled and ready for testing the switch mechanisms should be checked by hand pushing the membrane flush with the blade to check that the audio and/or visual signals on the control unit are activated.

5.2 Membrane calibration procedure

The membrane shall be calibrated to measure the values of the ΔP_A -suction and ΔP_B -pressure with the dilatometer equipment assembled and ready for testing immediately before inserting the blade into the soil and upon retrieval to the ground surface, both when running a dilatometer profiling or even a single test.

If the values of the membrane calibration pressures ΔP_A and ΔP_B , obtained before penetrating the blade into the soil, fall outside the limits $\Delta P_A = 5$ kPa to 30 kPa and $\Delta P_B = 5$ kPa to 80 kPa respectively, the membrane shall be replaced before testing commences.

After a membrane has been replaced, the new one shall be exercised to improve the stability of the ΔP_A and ΔP_B values. Such exercising may consist in pressurizing the membrane in air to 500 kPa for a few seconds. Care should be taken to avoid overexpansion and permanent deformations of the membrane.

After any membrane calibration the values of ΔP_A and ΔP_B shall be promptly recorded. All the obtained values of ΔP_A and ΔP_B shall be available on site.

During calibration the audio and/or visual signal activated by the electric switch shall stop and return sharply and unambiguously while sensing the 0,05 mm and 1,10 mm expansions respectively.

When testing soft soils the membrane calibration procedure shall be performed more than once to assure that stable values of ΔP_A and ΔP_B , falling within the prescribed limits, are constantly determined.

5.3 Performing the test

After the blade has been inserted into the soil and advanced to the selected test depth, the load applied to the push rods shall be released and the blade pressurized without delay to expand the membrane.

The rate of gas flow to pressurize the membrane shall be such that the P_A - reading is obtained within 20 s from reaching the test depth and the P_B - reading is obtained within 20 s after the P_A - reading.

Once P_B - has been determined the membrane shall be depressurized immediately, in order to prevent further expansion and permanent deformations, and the blade advanced to the next test depth or retrieved to the ground surface.

Depending on the system used to advance the blade, the pneumatic-electric cable connected to the blade shall be pre-threaded through the push rods for protection or left outside, using a slotted adaptor to egress it, and taped to the rod every 1 m.

If a friction reducer is used to limit the thrust needed to advance the blade, it shall be located at least 200 mm above the centre of the membrane.

After the blade has been retrieved to the ground surface and the membrane calibration procedure performed the values of ΔP_A and ΔP_B shall be recorded and compared with those measured previously. If the values of ΔP_A and ΔP_B measured before inserting the blade into the soil and after retrieval to the ground surface differ by more than 25 kPa then the test performed between the two successive calibration procedures shall be discarded.

6 Test results

Results of flat dilatometer tests can be interpreted using well established correlations to determine the subsoil stratigraphy, the deformation properties of cohesionless and cohesive soils, the in situ state of stress and the undrained shear strength of cohesive soils.

The interpretation of the results of flat dilatometer tests requires a knowledge of the in situ pore water pressure u_0 and the effective vertical stress σ'_{v0} prior to blade insertion. The value of u_0 at any test depth shall be determined from reliable pore water pressure measurements. The value of σ'_{v0} at any test depth shall be estimated from the unit weight of the soil layers above that depth and the in-situ pore pressure at the test depth.

When interpreting the results of flat dilatometer tests the values of p_0 , p_1 , u_0 and σ'_{v0} shall correspond consistently to the same test location and membrane depth.

The soil pressure p_1 against the flat dilatometer membrane when its centre is expanded 1,10 mm shall be determined using the following relationship:

$$p_1 = p_B - \Delta P_{B,avg} - Z_m.$$

The soil pressure p_0 against the flat dilatometer membrane when its centre is flush with the blade shall be determined with a linear back extrapolation from the soil pressure against the membrane at the two preset deflections, 0,05 mm and 1,10 mm, hence using the following relationship:

$$p_0 = 1,05 (P_A + \Delta P_{A,avg} - Z_m) - 0,05 p_1.$$

The material index I_{DMT} , the horizontal stress index K_{DMT} and the dilatometer modulus E_{DMT} shall be calculated using the following relationships:

$$— I_{DMT} = (p_1 - p_0) / (p_0 - u_0)$$

$$— K_{DMT} = (p_0 - u_0) / \sigma'_{v0}$$

$$— E_{DMT} = 34,7 (p_1 - p_0)$$

7 Report

7.1 Field report

The field report, signed by the operator in charge, shall contain the field logs and relevant observations made during the tests (weather conditions, interruption of operations, unusual events etc.).

7.2 Test report

In the test report, all DMT field investigations shall be reported about (field report, presentation of results etc.).

In addition the test report shall include the following information for identification and quality assurance purposes:

- a) rig and rod types;
- b) characteristics of systems used to advance the blade;
- c) predrilling depth and system to support the borehole if any;
- d) diameter and location of friction reducer if used;

CEN ISO/TS 22476-11:2005

- e) thrust applied to the push rods and at the top of the blade if measured;
- f) elevation of the groundwater table;
- g) procedures to calculate the pore pressure against the membrane at each test elevation;
- h) characteristics of the measuring system to obtain the in situ pore pressure when relevant;
- i) zero readings of pressure measurement devices;
- j) values of the ΔP_A - and ΔP_B -calibration-pressures measured before and after each dilatometer profiling or single test and corresponding average values;
- k) tabulated output of values of P_A - and P_B -pressure-readings;
- l) tabulated output of the calculated values of p_0 - and p_1 -pressure;
- m) any relevant observation such as incidents, equipment damage during testing, repairs and replacements, details not included in the above list which may affect the interpretation of test results;
- n) name and signature of the field manager.

Bibliography

EN 1997-1, *Eurocode 7: Geotechnical design — Part 1: General Rules*.

EN 1997-2, *Eurocode 7: Geotechnical design — Part 2: Ground investigation and testing*.

BSI — British Standards Institution

BSI is the independent national body responsible for preparing British Standards. It presents the UK view on standards in Europe and at the international level. It is incorporated by Royal Charter.

Revisions

British Standards are updated by amendment or revision. Users of British Standards should make sure that they possess the latest amendments or editions.

It is the constant aim of BSI to improve the quality of our products and services. We would be grateful if anyone finding an inaccuracy or ambiguity while using this British Standard would inform the Secretary of the technical committee responsible, the identity of which can be found on the inside front cover.
Tel: +44 (0)20 8996 9000. Fax: +44 (0)20 8996 7400.

BSI offers members an individual updating service called PLUS which ensures that subscribers automatically receive the latest editions of standards.

Buying standards

Orders for all BSI, international and foreign standards publications should be addressed to Customer Services. Tel: +44 (0)20 8996 9001.
Fax: +44 (0)20 8996 7001. Email: orders@bsi-global.com. Standards are also available from the BSI website at <http://www.bsi-global.com>.

In response to orders for international standards, it is BSI policy to supply the BSI implementation of those that have been published as British Standards, unless otherwise requested.

Information on standards

BSI provides a wide range of information on national, European and international standards through its Library and its Technical Help to Exporters Service. Various BSI electronic information services are also available which give details on all its products and services. Contact the Information Centre.
Tel: +44 (0)20 8996 7111. Fax: +44 (0)20 8996 7048. Email: info@bsi-global.com.

Subscribing members of BSI are kept up to date with standards developments and receive substantial discounts on the purchase price of standards. For details of these and other benefits contact Membership Administration.
Tel: +44 (0)20 8996 7002. Fax: +44 (0)20 8996 7001.
Email: membership@bsi-global.com.

Information regarding online access to British Standards via British Standards Online can be found at <http://www.bsi-global.com/bsonline>.

Further information about BSI is available on the BSI website at <http://www.bsi-global.com>.

Copyright

Copyright subsists in all BSI publications. BSI also holds the copyright, in the UK, of the publications of the international standardization bodies. Except as permitted under the Copyright, Designs and Patents Act 1988 no extract may be reproduced, stored in a retrieval system or transmitted in any form or by any means – electronic, photocopying, recording or otherwise – without prior written permission from BSI.

This does not preclude the free use, in the course of implementing the standard, of necessary details such as symbols, and size, type or grade designations. If these details are to be used for any other purpose than implementation then the prior written permission of BSI must be obtained.

Details and advice can be obtained from the Copyright & Licensing Manager.
Tel: +44 (0)20 8996 7070. Fax: +44 (0)20 8996 7553.
Email: copyright@bsi-global.com.