

BS 9991:2015



BSI Standards Publication

Fire safety in the design, management and use of residential buildings – Code of practice

bsi.

...making excellence a habit.™

Publishing and copyright information

The BSI copyright notice displayed in this document indicates when the document was last issued.

© The British Standards Institution 2015

Published by BSI Standards Limited 2015

ISBN 978 0 580 86739 2

ICS 13.220.01; 91.040.30

The following BSI references relate to the work on this document:

Committee reference FSH/14

Draft for comment 15/30301829 DC

Publication history

First published December 2011

Second (present) edition, October 2015

Amendments issued since publication

Date	Text affected
------	---------------

Contents

Foreword *vii*

Section 1: General 1

0 Introduction 1

1 Scope 9

2 Normative references 9

3 Terms and definitions 12

4 General recommendations 18

4.1 Basis of design 18

4.2 Variation of recommendations 19

4.3 Property protection and business continuity 19

4.4 Environment 20

4.5 Atria 20

4.6 Inclusive design 21

Section 2: Designing means of escape 22

5 General 22

5.1 Escape by way of doors and windows 22

5.2 Escape from basements 23

6 Means of escape and provision for rescue from houses 24

6.1 Single and two-storey houses 24

6.2 Inner rooms in houses 24

6.3 Houses with one floor more than 4.5 m above ground level 24

6.4 Houses with more than one floor higher than 4.5 m above ground level 25

6.5 Loft conversions 25

7 Means of escape from flats and maisonettes 26

7.1 General 26

7.2 Alternative exits from flats and maisonettes 27

7.3 Escape routes from flats and maisonettes with balcony approach or deck approach 27

7.4 Escape routes from flats and maisonettes with corridor or lobby approach 33

7.5 Small buildings 33

8 Means of escape from specialized housing 37

8.1 General 37

8.2 Travel distances 37

8.3 Protected stairways and corridor zones 37

8.4 Vertical transportation 37

8.5 Furnished areas in corridors 38

8.6 Doors 38

8.7 Electric wheelchairs and mobility scooters 38

9 Internal planning of flats and maisonettes 39

9.1 General 39

9.2 Basement flats 39

9.3 Flats or maisonettes situated not more than 4.5 m above ground or access level 39

9.4 Flats situated more than 4.5 m above ground or access level 40

9.5 Internal planning of maisonettes 43

9.6 Flats with galleries 47

9.7 Open-plan flat design 47

9.8 Cluster accommodation 48

Section 3: Active fire protection	50
10 Fire detection and fire alarm systems	50
10.1 General	50
10.2 Automatic fire detection and fire alarm systems for mixed-use buildings	50
11 Automatic fire suppression systems	51
11.1 General	51
11.2 Permitted variations	51
12 Manual fire-fighting equipment	54
13 Special risk protection	54
14 Smoke control	55
14.1 Smoke control for means of escape	55
14.2 Heat and smoke control for fire-fighting	57
14.3 Design, installation, commissioning and maintenance	62
15 Power supplies, cabling and installation	62
Section 4: Design for construction	64
16 Fire resistance	64
16.1 General	64
16.2 Minimum levels of fire resistance for elements of structure	64
17 Compartmentation	72
18 External fire spread and building separation	73
18.1 General	73
18.2 External fire spread over the external faces of buildings	74
18.3 Boundaries	74
18.4 Unprotected area	78
18.5 Degree of separation	79
18.6 Roofs	81
19 Concealed spaces	84
19.1 Provision of cavity barriers	84
19.2 Construction and fixings for cavity barriers	88
20 Materials	89
20.1 Internal linings	89
20.2 Suspended or stretched-skin ceilings	89
20.3 Non-combustible materials	89
20.4 Special roof coverings	90
21 Service ducts, pipes and shafts	90
21.1 Service shafts	90
21.2 Installation of ductwork systems	90
21.3 Flues	91
21.4 Protection of pipe openings	91
22 Glazed fire-resisting elements	93
22.1 General	94
22.2 Limitations of non-insulating fire-resisting glazing	95
22.3 Glazed screen separating protected shaft from lobby or corridor	96
22.4 Glazing and the effects of sprinklers	96
23 Active fire curtain/barrier assemblies	97
24 Openings	98
24.1 Fire doors	98
24.2 Shutter assemblies	105
24.3 Access panels	105
24.4 Fire-stopping	105

25	Floors and ramps on escape routes	106
26	Design and construction of common stairs	106
Section 5: Stairs and final exits 107		
27	Number and siting of common stairs	107
28	Width of common stairs	107
29	Enclosure of common stairs	107
30	Basement stairs	109
30.1	Multiple stair buildings	109
30.2	Single stair buildings	109
31	Stairs within mixed-use developments	110
32	Access lobbies and corridors to protected stairways	110
33	External stairs	111
34	Discharge from common stairs and final exits	112
Section 6: Mechanical systems for ducted heating, ventilation and air conditioning (HVAC) 114		
35	HVAC systems within individual dwellings	114
36	HVAC systems serving the whole building or interconnecting dwellings and other residential units	114
Section 7: Ancillary accommodation to flats and maisonettes 117		
37	General recommendations for ancillary accommodation	117
38	Places of special fire hazard	119
39	Installation of engineering services	119
40	Engineering service installation rooms	119
41	Gas services, installation and service pipes	120
42	Electrical services	120
42.1	Electrical service installations	120
42.2	Transformer, battery and switchgear rooms	120
42.3	Fire-fighter's emergency switches for discharge lighting installations	121
43	Gas and electricity meters	121
44	Lighting	122
44.1	Types of luminaire	122
44.2	Lighting of common escape routes in buildings containing flats or maisonettes	122
44.3	Protected circuits	123
45	Lift machine rooms and machinery spaces	123
46	Communal heating, ventilation and air conditioning systems	123
47	Refuse storage, disposal and incineration	124
48	Car parks and domestic garages	124
48.1	Car parks within or adjoining buildings	124
48.2	Domestic garages adjoining buildings	125
Section 8: Access and facilities for fire-fighting 126		
49	General recommendations for fire-fighting facilities	126
50	Fire-fighting access	127
50.1	Access for fire appliances	127
50.2	Access for fire-fighters	128

50.3	Construction of fire-fighting shafts	129
51	Water supplies for fire and rescue service fire-fighting use	130
51.1	Fire mains	130
51.2	Location and access to external water supply	131
52	Information for fire and rescue service use	132
Section 9: Management 133		
53	Management of specialized housing	133
54	Evacuation of disabled occupants or occupants that require assistance to escape	133
55	Residents	134
56	Caretakers	134
57	Maintenance of fire protection measures	134
58	Maintenance of building plant and equipment	135
59	Ensuring that systems respond properly in an emergency	135
59.1	Escape routes	135
59.2	Maintenance of fire safety equipment and provisions	136
59.3	Fire-fighting access and equipment	137
59.4	Contingency planning	137
Section 10: Building works: Material alterations, extensions, refurbishment, change of use, disuse, decommissioning and demolition 138		
60	Design of works	138
61	Change of use	138
62	Refurbishments	138
63	Dwellings in disuse and areas decommissioned	138
64	Managing building work and material alterations	139
65	Building works to occupied or partly occupied buildings	139
Annexes		
Annex A (informative) Methods of smoke ventilation		140
Annex B (normative) Additional recommendations for property protection and business continuity		142
Annex C (normative) Atria		147
Annex D (normative) Private balconies (open or enclosed) and communal roof gardens		161
Annex E (informative) Management of additional needs and disabilities		163
Annex F (informative) Advice to occupiers of dwellings in residential buildings		165
Bibliography		171
List of figures		
Figure 1 – Alternative arrangements for escape via the ground storey in houses exceeding 4.5 m in height		25
Figure 2 – Maisonette with alternative exits from each room not on the floor of entrance		28
Figure 3 – Maisonette with protected entrance hall and protected landing		29
Figure 4 – Open-plan maisonette		30
Figure 5 – Common escape routes in balcony/deck approach buildings		31
Figure 6 – Common escape routes in single stair buildings with a floor level more than 11 m above ground		34
Figure 7 – Common escape routes in multi stair buildings		35
Figure 8 – Common escape routes in small single stair buildings		36

Figure 9 – Furnished areas in specialized housing corridors	38
Figure 10 – Flat with restricted travel distance	40
Figure 11 – Flat with a protected entrance hall and restricted travel distance	41
Figure 12 – Flat with an alternative exit	42
Figure 13 – Flat (entered from below) with a restricted travel distance	44
Figure 14 – Flat (entered from below) with a protected entrance hall and restricted travel distance	45
Figure 15 – Flat (entered from above or below) with an alternative exit	46
Figure 16 – Typical cluster accommodation layout	48
Figure 17 – Provisions for external surfaces of walls	75
Figure 18 – Relevant boundaries	76
Figure 19 – Notional boundaries	77
Figure 20 – Combustible surface material as unprotected area	78
Figure 21 – Exclusions from unprotected area calculations	79
Figure 22 – Roof covering adjoining line of compartmentation	81
Figure 23 – Limitations on spacing and size of plastic roof lights having a Class 3 or TP(b) lower surface	83
Figure 24 – Provisions for cavity barriers	85
Figure 25 – Cavity wall excluded from provisions for cavity barriers	86
Figure 26 – Fire-resisting ceiling below concealed space	87
Figure 27 – Provisions for cavity barriers in double skinned insulated roof sheeting	87
Figure 28 – Flues and compartment walls and floors	92
Figure 29 – Enclosure for drainage or water supply pipes	93
Figure 30 – Pipes penetrating structure	93
Figure 31 – Protected routes forming an internal angle	108
Figure 32 – Staircase separating basement and upper storeys in single stair residential buildings	109
Figure 33 – Fire resistance of areas adjacent to external stairs	111
Figure 34 – Lobby protection to final exit from stairway	113
Figure 35 – Components of a residential fire-fighting shaft	131
Figure C.1 – Occupancy category decision process	148
Figure C.2 – Exemplar 1: Atrium base: no control required	149
Figure C.3 – Exemplar 2: Atrium base: no control required	150
Figure C.4 – Exemplar 3a: Atrium base: controlled fire load	151
Figure C.5 – Exemplar 3b: Atrium base: controlled fire load	152
Figure C.6 – Exemplar 3c: Atrium base: controlled fire load	153
Figure C.7 – Exemplar 4: Atrium base: controlled fire load	154
Figure F.1 – General fire safety advice for occupiers of dwellings in residential buildings	167
Figure F.2 – Example of a fire instruction notice for use in flats	169
Figure F.3 – Example of a fire instruction notice for use in other residential buildings	170

List of tables

Table 1 – Housing typology	6
Table 2 – AWFSS and categories for use with permitted variations	52
Table 3 – Minimum fire resistance performance	67
Table 4 – Fire resistance periods for elements of structure (independent of ventilation conditions)	71
Table 5 – Fire resistance periods for elements of structure (based on ventilation conditions)	71
Table 6 – Provisions for fire-protecting suspended ceilings	72
Table 7 – Small residential unprotected area limits and boundary distances	81

Table 8 – Separation distances for roof coverings	82
Table 9 – Separation distance for plastic roof lights	83
Table 10 – Maximum nominal interior diameter of pipes passing through a compartment wall/floor	92
Table 11 – Limitations on non-insulating fire-resisting glazed elements installed in buildings containing flats or maisonettes	96
Table 12 – Provisions for fire doors	100
Table 13 – Lobby ventilation	109
Table 14 – Maximum travel distances in areas of ancillary accommodation	118
Table 15 – Structural fire protection of areas of ancillary accommodation	118

Summary of pages

This document comprises a front cover, an inside front cover, pages i to viii, pages 1 to 174, an inside back cover and a back cover.

Foreword

Publishing information

This British Standard is published by BSI Standards Limited, under licence from The British Standards Institution, and came into effect on 31 October 2015. It was prepared by Technical Committee FSH/14, *Fire precautions in buildings*. A list of organizations represented on this committee can be obtained on request to its secretary.

Supersession

This British Standard supersedes BS 9991:2011, which is withdrawn.

Relationship with other publications

This standard complements BS 9999, which excludes individual dwelling houses, certain residential buildings and specialized housing from its scope. BS 9991 provides guidance on all of these building types.

Information about this document

This is a full revision of the standard, and introduces the following principal changes:

- change from “sheltered or extra care housing” to “specialized housing” and expansion of related recommendations;
- expanded recommendations for escape from basements;
- updating of recommendations relating to lifts;
- inclusion of new recommendations for power supplies;
- inclusion of new recommendations for cluster accommodation;
- inclusion of new guidance on the management of additional needs and disabilities;
- general update to take into account new and revised standards published since 2011.

Use of this document

There might be circumstances where it is necessary to use one publication to supplement another, but care needs to be taken when using a “pick-and-mix” approach as it is essential to ensure that an integrated approach is used in any one building.

As a code of practice, this British Standard takes the form of guidance and recommendations. It should not be quoted as if it were a specification and particular care should be taken to ensure that claims of compliance are not misleading.

Any user claiming compliance with this British Standard is expected to be able to justify any course of action that deviates from its recommendations.

It has been assumed in the preparation of this British Standard that the execution of its provisions will be entrusted to appropriately qualified and experienced people, for whose use it has been produced.

Presentational conventions

The provisions in this standard are presented in roman (i.e. upright) type. Its recommendations are expressed in sentences in which the principal auxiliary verb is “should”.

Commentary, explanation and general informative material is presented in smaller italic type, and does not constitute a normative element.

Where words have alternative spellings, the preferred spelling of the Shorter Oxford English Dictionary is used (e.g. “organization” rather than “organisation”).

Contractual and legal considerations

NOTE References are made throughout this British Standard to legislation and guidance applicable in the UK. It is recognized, however, that the standard might be used outside the UK, and in such circumstances, readers of the standard need to be aware of the legislative requirements and sources of further information applicable in their own countries.

Broadly speaking, fire safety legislation in the UK sets out fire safety objectives for various types of premises and their associated activities, and specifies who is responsible for ensuring that they are met. Individual items of legislation generally refer to, and give legal force to, named sets of regulations that are more detailed than the parent legislation. They either specify how certain activities are to be performed, and duties discharged, or they state functional requirements, i.e. they describe the outcome(s) required. When functional requirements are given, the regulations usually refer to other technical guidance and/or standards, including British Standards. Reference is made throughout the text to legislative material of which users of this British Standard need to be aware.

Attention is drawn to regulatory requirements in respect of the following principal stages in the lifetime of a building:

- a) planning – type, size, use, appearance, access and location of a proposed building;
- b) construction – materials, methods, nature and extent of both structural and installed fire safety features, internal and external arrangements for access, and proximity to other buildings;
- c) use – occupants’ activities, including storage and use of materials, provision of first aid fire-fighting equipment and fire safety training for occupants, and maintaining means of escape;
- d) maintenance – maintenance of fire safety systems and equipment in occupied and unoccupied buildings;
- e) material alterations and extensions – changes in fire risk or fire safety provisions; fire safety arrangements during construction work;
- f) change of use – changes in fire risk or fire safety provisions;
- g) demolition – fire safety arrangements during demolition work;
- h) when empty – empty buildings are particularly vulnerable to arson.

Attention is drawn to the Building Regulations 2010 [1], the Regulatory Reform (Fire Safety) Order 2005 [2], and the equivalent regulations in Wales, Scotland and Northern Ireland ([3] to [7]). Particular attention is drawn to the legal requirement under Regulation 38 of the Building Regulations 2010 [1] for relevant fire safety information to be provided to the responsible person on completion of the building, and to the requirements of the Construction Products Regulations 2013 [8].

This publication does not purport to include all the necessary provisions of a contract. Users are responsible for its correct application.

Compliance with a British Standard cannot confer immunity from legal obligations.

Section 1: General

0 Introduction

0.1 General principles

The design of buildings for fire safety relies upon an understanding of the sources of fire, materials and systems likely to be involved in fire, how people use buildings, and the likely spread of fire.

The recommendations and guidance given in this British Standard are based on the assumption that under normal circumstances (i.e. except in the case of arson) a fire is unlikely to start in two different places in a building.

All fire safety measures, procedures, etc. need to take into account the particular circumstances of the individual building or complex concerned. The same recommendations generally apply to both existing and new buildings, but existing buildings, especially historic buildings, often pose problems which are unlikely to arise in new buildings. In assessing the fire safety management needs of an existing building which is being modified, it is essential to have a full understanding of the existing structure and any fire safety provisions incorporated, and to take into account all of the following:

- a) any change in use of the premises which could affect the fire risk profile (e.g. increased fire load and process risks, changes to sleeping risk, seasonal changes);
- b) how the necessary fire safety levels can be practicably achieved in the existing premises and whether they are appropriate;
- c) historic and environmental aspects of the premises and to what extent they need to be disturbed;
- d) legislation and guidance introduced since the premises were originally constructed, or last altered, or since their fire safety was last assessed;
- e) the interrelationship between life safety and measures to protect property/contents;
- f) business continuity.

Historic buildings present particular challenges, as many are listed and permitted material alterations are therefore limited without the agreement of the appropriate authorities. For such buildings, it is advisable to seek the advice of consultative bodies, such as Historic England, Historic Scotland and the Northern Ireland Environment Agency, in the early stages of design. The appropriate authorities sometimes agree to limited modifications to improve life safety where, in turn, there will be added long-term protection and preservation of the original building fabric.

NOTE *Historic Scotland Guides for Practitioners 6 [9] and 7 [10] contain guidance on, respectively, conversion and fire safety management of traditional buildings.*

Specific issues relating to historic buildings can be divided into four areas:

- 1) the preservation of the ambience and important features of the building such as timber linings to accommodation stairs and slender cast iron structure, both of which can sometimes conflict with the desired fire safety construction but can be accommodated with suitable compensating features;
- 2) the existing construction of the building, including hidden features such as the extent of cavities through which fire could spread and the quality of walls, partitions and floors (the fire resistance of which might be unknown

or questionable). Life safety can often be addressed by the use of suitable compensating features, but these do not always cover property protection and business interests;

- 3) the fire performance of the building structure. Although modern construction standards seldom apply to historic buildings, action to improve the level of fire and life safety might be necessary based on change of use or due to the need to reduce the fire risk and potential for loss of the structure and/or interior in any other context;
- 4) the sensitivity of historic structures and interiors (finishes and contents) to fire and smoke damage.

In both new construction and upgrading existing buildings, the various aspects of fire precautions are interrelated and weaknesses in some areas can be compensated for by strengths in others. A higher standard under one of the areas might be of benefit in respect of one or more of the other areas. BS 9991 provides a level of flexibility that allows the fire protection measures and the risks to be assessed to enable reasonable practical solutions to be designed.

Fire precautions in all premises – however old – need to be seen as a whole, a package aimed at achieving an acceptable standard of fire safety. In modifying existing structures, if the new work can be shown not to have a negative impact on the remainder, it is likely that no work will be needed on the remainder, although it might be possible to offer improvement as good practice.

The principles and recommendations in this British Standard apply straightforwardly where premises have a single main use and are contained in a single, separate building. Complications might arise, however, where a building comprises two or more different main uses. In such cases it is important to consider the effect of one risk on another. A fire in a shop or unattended office could have serious consequences on, for example, a residential use in the same building. Similarly, a high fire risk in one part of a building could seriously affect other areas in another part of that building.

Amongst the factors that need to be taken into account in establishing a minimum package of fire protection measures are:

- i) the potential users of the building;
- ii) the hazard posed by one occupancy to another;
- iii) provision for giving warning in case of fire, including any automatic fire detection;
- iv) the provision of automatic fire suppression systems and smoke control arrangements;
- v) the overall management and control of the building or development, from a fire safety point of view;
- vi) structural fire protection and compartmentation;
- vii) the security of and access to the building.

BS 9991 provides recommendations and guidance on the provision of measures to control or mitigate the effects of fire. The primary objective is to ensure that an adequate standard of life safety can be achieved in the event of fire in the building. A secondary objective is to provide a level of protection for property and businesses against the impact of fire, e.g. in close proximity to residential buildings or as part of the same building or building complex. These can also have the effect of assisting the fire and rescue service and/or of providing environmental protection. There are references throughout this British Standard to occupant safety, fire-fighter safety and property protection, to draw attention to the different issues these could raise. It is, however, important to be aware

that provisions solely for life safety are unlikely to provide the full level of protection for buildings and property in a fully developed fire scenario.

0.2 Flats and maisonettes

0.2.1 General principles

The means of escape from a flat or a maisonette of limited height is relatively simple. With increasing height more complex provisions are needed because emergency egress through upper windows becomes increasingly hazardous.

The provisions for means of escape for flats or maisonettes are based on the assumptions that:

- a) provided that the building is well managed and corridors/stairways are kept clear, fire is more likely to occur within the flat or maisonette than in the common parts (e.g. not in a stairwell);
- b) there can be no reliance on external rescue (e.g. a portable ladder);
- c) the flat or maisonette will have a high degree of compartmentation and therefore there will be a low probability of fire spread beyond the flat or maisonette of origin, so in most fires simultaneous evacuation of the building is unlikely to be necessary; and
- d) where fires do occur in the common parts of the building, the materials and construction used in such areas will prevent the fire from spreading beyond the immediate vicinity (although in some cases communal facilities exist which require additional measures to be taken).

In purpose-built blocks of flats, special provisions are made to ensure that a fire is contained within the flat of origin and that common escape routes and stairways remain relatively free from smoke and heat in the event of a fire within a dwelling. For this reason, the general fire strategy is a stay put strategy (see 3.58 and A.1).

NOTE It is important that information is given to residents regarding the meaning of the stay put strategy and the arrangements for means of escape available to them if a fire affects their flat.

Whilst a simultaneous evacuation is normally unnecessary (see A.1 regarding stay put strategy), there will be some occasions where operational conditions are such that the fire and rescue service decide to evacuate the building. In these situations the occupants of the building will need to use the common stair, sometimes whilst fire-fighting is in progress. As such, the measures in this British Standard for the protection of common stairs are designed to ensure that they remain available for use over an extended period.

0.2.2 Protection of common escape routes

When making provision for the protection of common escape routes, i.e. from the exit of an individual dwelling to the final exit, it is essential to have a full understanding of the existing structure and any fire safety provisions incorporated, and to take into account the factors listed in 0.1a) to 0.1f).

Recommendations for compartmentation and common escape routes are given in Clause 17 and Section 2.

0.2.3 Smoke control in common parts

It is probable that some smoke from a fire in a flat or maisonette will enter the common parts of the building, i.e. the common corridor and/or lobby, for example as a result of occupants escaping or through the operational procedures of fire-fighters. It is therefore necessary to provide some means of controlling smoke in the common corridors/lobbies to provide protection to the stairways and other common areas.

Smoke can be controlled in the common areas through fitted ventilation systems which are either natural or mechanical. These ventilation systems have two main purposes: to provide some protection to the stair core, and to aid fire-fighters when tackling a fire. Ventilation systems can also be used to compensate for extended travel distances within the common corridor leading to the stairs and thereby help occupants to escape safely. Where smoke control is used to provide compensation for extended travel distances, it is the responsibility of the designers to demonstrate that the ventilation system can provide tenable conditions (see Annex A) for the occupants using the route with extended travel distances.

0.2.4 Protection of common stairs

Routes to common stairs need to meet the applicable travel distance recommendations and provide alternative directions of travel from any dwelling leading to common stairs, other than accepted dead ends, to enable occupants to exit the building safely. All common stairs need to have a level of fire protection involving fire-resisting construction and a smoke control system which enables them to provide occupants of the building with a safe means of escape.

The fire-resisting enclosure of a common stair is provided to prevent smoke and heat from entering the stairway, rendering it impassable for escape purposes, and to prevent fire spreading from one storey to another.

Once inside a protected stairway, a person can be considered to be in a place of relative safety from the immediate danger of flame and smoke. They can then proceed to a place of ultimate safety at their own pace. While unprotected stairways are acceptable for daily human traffic around buildings, their vulnerability to fire and smoke means that it is vital that they are not used primarily as a means of escape from fire.

Particular care needs to be taken in the design of basement stairs, as it is more probable that the stairs at this level will become filled with smoke and heat, than ground or upper storeys if a fire occurs at basement level.

0.2.5 Fire alarm and fire detection system

In most flats, the installation of smoke alarms or fire detection and alarm systems can significantly increase the level of safety by automatically giving an early warning of fire. Generally a common fire alarm and/or fire detection system would not be provided for the evacuation of the occupants. This is to ensure that during the initial stages of a fire in a flat or maisonette, only those persons in the immediate area of the fire are alerted. Recommendations for fire alarm and fire detection systems are given in Section 3.

0.2.6 Automatic water fire suppression system (AWFSS)

The installation of an AWFSS can offer designers considerable flexibility. An AWFSS controls a fire to a small size, reducing the production of smoke and toxic gases and preventing the fire from spreading beyond the room or dwelling of origin. This means that there can be flexibility achieved in the design of the building. An AWFSS would also provide a good standard of protection for property.

NOTE Attention is drawn to legislative requirements in respect of the need for AWFSS in certain buildings.

0.3 Houses in multiple occupation (HMOs)

HMOs, because of their likely occupational uses, can vary in risk between not much more than a single family dwelling to greater than a hotel. As such, the recommendations given in this British Standard are not always entirely relevant. More detailed guidance can be found in the LACORS publication *Housing – Fire safety* [11].

Further advice and information can be obtained from the environmental health department of the local council, who administer safety and licensing, where necessary, of such premises, and might have specific requirements in their administrative area.

Guidance concerning the licensing of HMOs can be found at www.gov.uk/house-in-multiple-occupation-licence¹⁾.

NOTE Attention is drawn to Sections 254 to 259 of the Housing Act 2004 [12] in respect of HMOs.

0.4 Housing typology

A broad spectrum of housing options is available which fall into three separate categories:

- mainstream housing;
- specialized housing; and
- residential care (also known as care homes).

The categories each contain a number of sub-categories as shown in Table 1. The number of sub-categories is due to developers seeking to define the intended residents' differing levels of need (due to their level of physical ability and mental cognisance) and consequently their care and support requirements. The fire safety provisions between and within each housing category will vary as a result of the anticipated residents' vulnerabilities.

0.5 Accessible and adaptable housing

Where mainstream housing is at an early design stage, consideration needs to be given to the proposed design and internal layout to ensure that they are sufficiently robust to accommodate the increasing needs of occupants over time, whether that is a change to physical ability or mental cognisance. This is because the installation of additional or adaptable fire safety measures is easier if features are incorporated at design stage and can assist in future-proofing a building. For example, the provision of an AWFSS at design stage can raise the standard of fire safety in a dwelling to such an extent that future adaptation of the building might require fewer additional fire precautionary measures.

BS 9266 gives recommendations for the design of accessible and adaptable general needs housing.

¹⁾ Last accessed 27 October 2015.

Table 1 Housing typology

Category ^{A)}	Sub-categories ^{B)}	Descriptor
Mainstream housing		<i>Housing which ranges from premises with no special features to those which facilitate adaptation at design stage or post-build stage to support residents' additional needs</i>
	General needs	Housing with no special features
	Lifetime homes	Housing designed to meet access and adaptability standards for everyone including older people
	Adapted homes	Housing which has been changed to meet the needs of its residents
Specialized housing		<i>Housing specifically for people with a level of need who require support and care services</i>
	Sheltered/retirement	Independent living (own front door) Can include 24 h alarm system, warden, lounge, programme of activities
	Very sheltered/assisted living	Independent living with managed on-site care and support services Features as above; can also include meals, domestic help, assisted bathing
	Extra care	Independent living with managed on-site care and support service Features as above; can also include hairdressing service, 24 h staff
	Close care housing	Independent living with on-site care and support linked to a care home
	Retirement villages	Large developments (often 100+) with a range of housing types and levels of care and support (sheltered, very sheltered/extra care, close care and nursing care) on one site
Residential care (also known as care homes)		<i>Residential care or care homes offer institutional accommodation (suites of bedrooms) and personal care for people who might not be able to live independently</i> <i>Some homes also offer care from qualified nurses or specialize in caring for particular groups such as younger adults with learning disabilities</i>
	Residential homes	Institutional accommodation (suites of bedrooms) with meals, personal care (physical and emotional) with staff on call
	Nursing homes	Institutional accommodation (suites of bedrooms) with 24 h nursing care
	Specialized care homes	Institutional accommodation for specific needs including dementia

^{A)} Shaded categories fall outside the scope of BS 9991.

^{B)} This list is not exhaustive. A new development will be specialized housing if it does not fall within the mainstream housing or the residential care category.

0.6 Specialized housing

Specialized housing contains a diverse range of accommodation where the residents are likely to be less mobile, have other impairments or are otherwise vulnerable to emergency situations. This category can include housing for the elderly, children and people with a physical or mental impairment. Designers need to consider the characteristics of the residents of the building and incorporate an appropriate range of fire precautionary measures to secure a suitable level of fire safety within the building. Consideration also needs to be given to the residents' changing level of need over time in order to ensure that the building is future-proofed for an ageing population. This may include the provision of an AWFSS.

0.7 Tall and very tall buildings

The recommendations in this British Standard can be applied to residential buildings of any height.

Experience and research has shown that the inherent principles supporting a stay put strategy, in particular those requiring increased fire resistance as the height of a building increases, coupled with the installation of AWFSS, ensure that the level of risk from fire remains equivalent across the height range of residential buildings from low rise to tall buildings.

However, the increased design demands on structural integrity, services, fire safety systems, means of fire-fighting and evacuation generated by buildings in excess of 50 m high might mean that specific evaluation of all fire safety provisions is needed using a qualitative design review in accordance with BS 7974. This is to determine whether the recommendations in BS 9991 are appropriate, or whether a full fire engineered solution is required.

Enhanced measures of protection might be needed compared with single occupancy or lower risk building types. Those enhanced measures could be, for example, higher levels of fire resistance (either in terms of time or insulation) together with stronger measures in detection and alarm and a stronger emphasis on escape plans and directions to residents.

0.8 Management of fire safety

It is a fundamental assumption that features described in this British Standard will require management and maintenance throughout the life of the building.

Managing fire safety is the whole process throughout the life of a building, starting with the initial design, which is intended both to minimize the incidence of fire and to ensure that, when a fire does occur, appropriate fire safety systems (including active, passive, and procedural systems) are in place and are fully functional. Fire safety procedures and maintenance schedules are developed at the design stage and included in the fire safety manual, which is handed over to the person responsible for fire safety of the building in order to enable a suitable and sufficient fire risk assessment to be carried out.

NOTE Attention is drawn to Regulation 38 of the Building Regulations 2010 [1]. Attention is also drawn to the Regulatory Reform (Fire Safety) Order 2005 [2] and to the equivalent regulations in Scotland [6] and Northern Ireland [7].

The management of fire safety is thus an essential element in averting the loss of life in the event of a fire. Although many buildings will never have a serious life-threatening fire, it is essential for fire safety procedures to be planned for every building. There are usually numerous elements which contribute to multi-fatality fires, one being that, when fire is discovered or when the alarm is raised, the occupants of premises, be they staff or members of the public, react and respond in ways which are different from those assumed or expected by the building designer. There are a number of stages by which people react to a fire alarm. Initially they tend to seek information regarding the validity of the warning. They then gather belongings or seek associates or family. Only then do they seek to travel to a place of ultimate safety. The management of fire safety is intended to increase awareness and increase the probability of appropriate behaviour, to minimize the threat from the fire.

There have been numerous fire incidents, both large and small, where there have been lives lost or put at risk as a result of the safety systems provided being inappropriate or not being used effectively.

It is now widely acknowledged that the design and engineering put into a building for life safety can only do its job properly if it can be managed, maintained and tested over the whole life of the building, and if any staff (which will be determined by the management strategy of the building) who might be present are trained to handle incidents and operate effective and tested emergency plans.

Once the designer or engineer has handed over the building, then good management of fire safety becomes the key element to fire safety for the life of the building.

Effective management of fire safety can contribute to the protection of the building occupants in many ways:

- a) by working to prevent fires occurring in the first place;
- b) by carrying out effective risk assessments of fire safety precautions and built-in measures, including compartmentation and essential elements such as fire doors and fire-resistant walls and screens;
- c) by monitoring the fire risks on an ongoing basis and taking appropriate action to eliminate or reduce the risk;
- d) by being aware of the types of people in the building (such as disabled people, elderly people, children, pregnant women, etc.) and any special risks or needs;
- e) by ensuring that all of the fire safety measures in the building are kept in working order, and in particular that the means of escape are always available;
- f) by training any staff in the appropriate action to be taken in the event of a fire.

These tasks differ in detail depending on the occupancy of the building.

1 Scope

This British Standard gives recommendations and guidance on the design, management and use of the following building types, to achieve reasonable standards of fire safety for all people in and around:

- a) dwellings (single-family dwelling houses, self-contained flats or maisonettes);
- b) residential accommodation blocks (e.g. for students or hospital staff), with individual bedrooms and the provision of kitchen/sanitary facilities constructed within a fire compartment;
- c) specialized housing.

NOTE 1 Recommendations for fire safety in the design, management and use of buildings other than residential buildings are given in BS 9999.

It is not applicable to hotels, caravans/mobile homes, hospitals, residential care homes, places of lawful detention or hostels.

NOTE 2 Requirements for means of escape from caravans and mobile homes are given in BS 3632.

This British Standard is applicable to the design of new buildings, and to material alterations, extensions and material change of use of an existing building.

NOTE 3 Attention is drawn to the Building Regulations 2010 [1] and equivalent regional variations [3] to [5] in respect of the definition of material alterations, extensions and material change of use.

It also provides recommendations and guidance on the ongoing management of fire safety in a building throughout the entire life cycle of the building, including measures for designers to ensure that the overall design of a building assists and enhances the management of fire safety. It can be used as a tool for assessing existing buildings, although fundamental change in line with its recommendations might be limited or not practicable.

The recommendations and guidance given in this British Standard are intended to safeguard the lives of building occupants and fire-fighters. Whilst some of the recommendations and guidance might also assist in the achievement of other fire safety objectives – such as protection of property, the environment, communities and business/service viability – additional measures might be necessary which are outside the scope of this British Standard.

This British Standard does not cover fire safety design strategies for extreme events such as terrorist actions.

2 Normative references

Standards publications

The following documents, in whole or in part, are normatively referenced in this document and are indispensable for its application. For dated references, only the edition cited applies. For undated references, the latest edition of the referenced document (including any amendments) applies.

BS 476 (all parts), *Fire tests on building materials and structures*

BS 799-5, *Oil burning equipment – Part 5: Carbon steel oil storage tanks – Specification*

BS 3251, *Specification – Indicator plates for fire hydrants and emergency water supplies*

- BS 4514, *Unplasticized PVC soil and ventilating pipes of 82.4 mm minimum mean outside diameter, and fittings and accessories of 82.4 mm and of other sizes – Specification*
- BS 5234 (both parts), *Partitions (including matching linings)*
- BS 5255, *Specification for thermoplastics waste pipe and fittings*
- BS 5266-1, *Emergency lighting – Part 1: Code of practice for the emergency lighting of premises*
- BS 5306-0, *Fire protection installations and equipment on premises – Part 0: Guide for selection of installed systems and other fire equipment*
- BS 5306-3, *Fire extinguishing installations and equipment on premises – Part 3: Commissioning and maintenance of portable fire extinguishers – Code of practice*
- BS 5306-8, *Fire extinguishing installations and equipment on premises – Part 8: Selection and installation of portable fire extinguishers – Code of practice*
- BS 5395-1, *Stairs – Part 1: Code of practice for the design of stairs with straight stairs and winders*
- BS 5410-1, *Code of practice for oil firing – Part 1: Installations up to 45 kW output capacity for space heating and hot water supply purposes*
- BS 5410-2, *Code of practice for oil firing – Part 2: Installations of 45 kW and above output capacity for space heating, hot water and steam supply services*
- BS 5839 (all parts), *Fire detection and fire alarm systems for buildings*²⁾
- BS 5852, *Methods of test for assessment of the ignitability of upholstered seating by smouldering and flaming ignition sources*
- BS 5867-2:2008, *Fabrics for curtains, drapes and window blinds – Part 2: Flammability requirements – Specification*
- BS 5906, *Waste management in buildings – Code of practice*
- BS 6180, *Barriers in and about buildings – Code of practice*
- BS 6262-4, *Glazing for buildings – Part 4: Code of practice for safety related to human impact*
- BS 6263-2, *Care and maintenance of floor surfaces – Part 2: Code of practice for resilient sheet and tile flooring*
- BS 6400 (all parts), *Specification for installation, exchange, relocation and removal of gas meters with a maximum capacity not exceeding 6 m*
- BS 6644, *Specification for installation of gas-fired hot water boilers of rated inputs between 70 kW (net) and 1.8 MW (net) (2nd and 3rd family gases)*
- BS 6798, *Specification for selection, installation, inspection, commissioning, servicing and maintenance of gas-fired boilers of rated input not exceeding 70 kW net*
- BS 7157:1989, *Method of test for ignitability of fabrics used in the construction of large tented structures*
- BS 7176, *Specification for resistance to ignition of upholstered furniture for non-domestic seating by testing composites*
- BS 7273-4, *Code of practice for the operation of fire protection measures – Part 4: Actuation of release mechanisms for doors*

²⁾ This standard gives dated references to BS 5839-1:2013 and BS 5839-6:2013.

BS 7346-7, *Components for smoke and heat control systems – Part 7: Code of practice on functional recommendations and calculation methods for smoke and heat control systems for covered car parks*³⁾

BS 7346-8, *Components for smoke control systems – Part 8: Code of practice for planning, design, installation, commissioning and maintenance*³⁾

BS 7671, *Requirements for electrical installations – IET Wiring Regulations – Seventeenth edition*

BS 8214, *Code of practice for fire door assemblies*

BS 8313, *Code of practice for accommodation of building services in ducts*

BS 8414-1, *Fire performance of external cladding systems – Part 1: Test methods for non-loadbearing external cladding systems applied to the face of a building*

BS 8414-2, *Fire performance of external cladding systems – Part 2: Test method for non-loadbearing external cladding systems fixed to and supported by a structural steel frame*

BS 8519:2010, *Selection and installation of fire-resistant power and control cable systems for life safety and fire-fighting applications – Code of practice*

BS 8524 (both parts), *Active fire curtain barrier assemblies*

BS 9251:2014, *Sprinkler systems for residential and domestic occupancies – Code of practice*

BS 9990, *Non-automatic fire-fighting systems in buildings – Code of practice*⁴⁾

BS 9999, *Code of practice for fire safety in the design, management and use of buildings*

BS EN 3 (all parts), *Portable fire extinguishers*

BS EN 81 (all parts), *Safety rules for the construction and installation of lifts*

BS EN 1154, *Building hardware – Controlled door closing devices – Requirements and test methods*

BS EN 1363 (all parts), *Fire resistance tests*

BS EN 1364 (all parts), *Fire resistance tests for non-loadbearing elements*

BS EN 1365 (all parts), *Fire resistance tests for loadbearing elements*

BS EN 1366 (all parts), *Fire resistance tests for service installations*

BS EN 1634-1, *Fire resistance tests for door and shutter assemblies – Part 1: Fire resistance test for door and shutter assemblies and openable windows*

BS EN 1634-3:2004, *Fire resistance tests for door and shutter assemblies – Part 3: Smoke control test for door and shutter assemblies*

BS EN 12101 (all parts), *Smoke and heat control systems*

BS EN 12845, *Fixed firefighting systems – Automatic sprinkler systems – Design, installation and maintenance*

BS EN 13501 (all parts), *Fire classification of construction products and building elements*

BS EN 13823, *Reaction to fire tests for building products – Building products excluding floorings exposed to the thermal attack by a single burning item*

BS EN 60947 (all parts), *Low-voltage switchgear and controlgear*

³⁾ This standard also gives an informative reference to the entire BS 7346 series.

⁴⁾ This standard also gives an informative reference to BS 9990:2015.

BS EN ISO 1182, *Reaction to fire tests for building products – Non combustibility test*

BS EN ISO 1716, *Reaction to fire tests for products – Determination of the gross heat of combustion (calorific value)*

BS ISO 3864-1, *Graphical symbols – Safety colours and safety signs – Part 1: Design principles for safety signs and safety markings*

DD 8458-1, *Fixed fire protection systems – Residential and domestic watermist systems – Part 1: Code of practice for design and installation*⁵⁾

Other publications

[N1]COLWELL, S. and BAKER, T. *Fire performance of external thermal insulation for walls of multistorey buildings*. BR 135. Third edition. Watford: Building Research Establishment, 2013.

[N2]UKLPG. *Code of practice 1-2 – Bulk LPG storage at fixed installations for domestic purposes*. Incorporating amendment 2. UKLPG, 2000.

[N3]HEALTH AND SAFETY EXECUTIVE. *The keeping of LPG in cylinders and other containers*. Guidance note CS4. HSE, 1986.

3 Terms and definitions

For the purposes of this British Standard the following terms and definitions apply.

3.1 access level

level used for normal access to the building that either incorporates, or leads directly to, a place of ultimate safety

3.2 access room

room that forms the only escape route from an inner room (3.40)

3.3 accessible and adaptable housing

housing that is sufficiently flexible and convenient to meet the existing and changing requirements of most households, and in which the interior fabric rather than the structure can be easily adapted to accommodate aids and equipment

NOTE Such households might include older people, families with children, physically disabled people or those with sensory impairments. Aids and equipment might include stairlifts, hoists and grab rails that make it easier for older people and some disabled people to stay in their home when their access needs change.

3.4 alternative escape route (from a house)

route from any point within a room of a house that gives easy access to a second stair, a balcony or a flat roof by means of which a person can reach a place of ultimate safety

3.5 alternative exit (from a flat or maisonette)

one of two or more exits from within a flat or maisonette, each of which is separate from the other giving access to a route leading to a place of ultimate safety

⁵⁾ At the time of publication of BS 9991, DD 8458-1 is undergoing conversion to a full British Standard as BS 8458.

- 3.6 ancillary accommodation**
all parts of a building that are ancillary to the dwellings, such as rooms associated with engineering services, common amenity areas (3.12), refuse rooms and covered car parks
- 3.7 atrium (plural: atria)**
space within a building, not necessarily vertically aligned, passing through one or more compartment floor(s)
NOTE Enclosed lift wells, enclosed escalator structural openings, building services ducts and stairways are not classified as atria.
- 3.8 automatic water fire suppression system (AWFSS)**
system designed to control or extinguish fires without human intervention
NOTE This can be a sprinkler system or a watermist system depending upon the application. Details are given in 11.2, Table 2.
- 3.9 balcony approach**
design in which each dwelling is approached externally via an open common walkway, the amount of opening being uniformly distributed throughout its length between 1 100 mm and the soffit above to allow ventilation
- 3.10 basement**
storey with a floor which at some point is more than 1.2 m below the highest level of ground adjacent to the outside walls
- 3.11 Class 0 (material or surface)**
material or surface that is either:
a) of limited combustibility throughout; or
b) classified as Class 1 when tested in accordance with BS 476-7, which has a fire propagation index of not more than 12, and a subindex i_1 of not more than 6, when tested in accordance with BS 476-6
NOTE Class 0 is not identified in any British Standard test. European Classification B-s3, d2 is the general equivalent of Class 0. The European classifications are described in BS EN 13501-1. They are based on a combination of four European test methods, namely: BS EN ISO 1182; BS EN ISO 1716; BS EN 13823; and BS EN ISO 11925-2. The national classifications do not automatically equate with the equivalent classification in Europe; therefore, products cannot typically assume a European class, unless they have been tested accordingly.
- 3.12 common amenity area**
area containing household facilities that are remote from individual dwellings
NOTE Examples of common amenity areas include kitchens, laundries, drying areas and occupiers' stores.
- 3.13 common corridor**
protected corridor serving more than one flat or occupancy
- 3.14 common stair**
stairway serving more than one flat or occupancy
- 3.15 competent person**
person, suitably trained and qualified by knowledge and practical experience, and provided with the necessary instructions, to enable the required task(s) to be carried out correctly

- 3.16 corridor access**
design in which each dwelling is approached via a common horizontal internal access or circulation space
NOTE 1 Corridor access can include a common entrance hall.
NOTE 2 Corridor access is also referred to as a corridor approach.
- 3.17 dead end**
area from which escape is possible in one direction only
- 3.18 deck approach**
design in which each dwelling is approached externally via a wide approach common (external) walkway that has guarding only at the edges and otherwise is completely open to the atmosphere
NOTE This is also known as deck access.
- 3.19 depressurization**
method of smoke control in which the air pressure within the area of the fire or its adjacent areas is decreased so that it is lower than the air pressure within the protected area
- 3.20 dwelling**
unit of residential accommodation, occupied (whether or not as a sole or main residence):
- by a single person or by people living together as a family; or
 - by not more than six residents living together as a single household, including a household where care is provided for residents
- 3.21 dwelling of origin**
dwelling in which the initial ignition of a fire has occurred
- 3.22 emergency escape lighting**
lighting provided for use when the normal lighting fails, to ensure illumination of escape route(s) at all times
- 3.23 escape route**
route forming part of the means of escape from any point in a building to a final exit
- 3.24 final exit**
termination of a designated escape route, from which there is direct access to a place of ultimate safety (3.49)
- 3.25 fire doors**
- 3.25.1 fire door**
door assembly which, as installed in a building, is intended when closed to resist the passage of fire and is capable of meeting specified performance criteria
- 3.25.2 self-closing fire door**
fire door fitted with a device which fully closes the door, overriding the resistance of any latch
- 3.26 fire-fighting lift switch**
switch located at the fire service access level, outside the lift well, used to initiate fire-fighters' service

- 3.27 fire-fighting lobby**
protected lobby providing access from a fire-fighting stair to the accommodation area and to any associated fire-fighting lift
- 3.28 fire-fighting shaft**
protected enclosure containing a fire-fighting stair, fire-fighting lobbies, a fire main and, if provided, a fire-fighting lift together with any machinery space
- 3.29 fire-fighting stair**
protected stairway communicating with the accommodation area only through a fire-fighting lobby
- 3.30 fire resistance**
ability of an item to fulfil for a stated period of time the required fire stability and/or integrity and/or thermal insulation, and/or other expected duty specified in a standard fire resistance test
- 3.31 flat**
separate and self-contained premises, constructed or adapted for use for residential purposes and forming part of a building from some other part of which it is divided horizontally, having all its rooms on one level or not more than half a storey height apart
- 3.32 free area**
total unobstructed cross-sectional area of an opening, vent, etc., measured in the plane where the area is at a minimum and at right angles to the direction of air flow
NOTE The free areas of openings, vents, etc. refer to the geometric free area.
- 3.33 gallery**
floor or balcony which does not extend across the full extent of a building's footprint and is open to the floor below
- 3.34 ground storey**
storey, the floor of which is situated at such a level or levels that any given point on its perimeter is not more than 1.2 m below the level of the finished surface of the ground adjoining the building in the vicinity of that point
- 3.35 habitable room**
any room in a dwelling with the exception of any kitchen, utility room, bathroom or WC
- 3.36 higher fire risk area**
area with a fire risk higher than that of a dwelling
- 3.37 house**
unit of residential accommodation occupied (whether or not as a sole or main residence):
- a) by a single person or by people living together as a family; or
 - b) by not more than six residents living together as a single household, including a household where care is provided for residents
- NOTE This does not include a flat or a building containing a flat.*

3.38 house in multiple occupation (HMO)

building or part of a building:

- a) in which more than one household shares an amenity or the building lacks an amenity; or
- b) which is a converted building that does not entirely comprise self-contained flats (whether or not there is also a sharing, or lack, of amenities); or
- c) which is comprised entirely of converted self-contained flats and where the standard of conversion does not meet a specified minimum, and more than one third of the flats are occupied under short tenancies

NOTE 1 Examples of amenities are bathrooms, toilets and cooking facilities.

NOTE 2 Attention is drawn to the Building Regulations 2010 [1] and equivalent regional variations ([3] to [5]) in respect of the specified minimum standard of conversion.

3.39 independent alternative escape route

one of two or more escape routes from a dwelling, with its own separate exit from the dwelling and which follows a route that is separate from the other(s)

3.40 inner room

room from which escape is possible only by passing through another room

3.41 level of need

degree of vulnerability to fire based on:

- a) propensity to contribute to the starting of fire or to the development of fire;
- b) capacity to respond appropriately to signs of fire or other cues; and
- c) ability to escape in the event of fire

3.42 lifts**3.42.1 lift**

lifting device within the scope of BS EN 81-20, with completely enclosed car and rated speed greater than 0.15 m/s, permanently serving a building and intended for the transport of persons or persons and goods

3.42.2 evacuation lift

lift used as part of the evacuation sequence for persons with disability and persons requiring assistance, which has appropriate structural, electrical and fire protection and is capable of being taken under control by a trained and authorized person

3.42.3 fire-fighting lift

lift with protection measures, controls and signals that enable it to be used under the direct control of the fire and rescue service in fighting a fire

3.43 maisonette

dwelling, forming part of a larger building, having rooms divided between two or more levels which are more than half a storey height apart

3.44 mainstream housing

housing which ranges from premises with no special features to those which facilitate adaptation at design stage or post-build stage to support residents' additional needs

NOTE Further guidance on housing definitions can be found in Table 1.

3.45 material of limited combustibility

either:

- a) a non-combustible material; or
- b) any material of density 300 kg/m³ or more which, when tested in accordance with BS 476-11, does not flame and the rise in temperature on the furnace thermocouple is not more than 20 °C; or
- c) any material with a non-combustible core of 8 mm thick or more, having combustible facings (on one or both sides) not more than 0.5 mm thick; or
- d) a material classified as class A2-s3, d2 in accordance with BS EN 13501-1, when tested in accordance with BS EN ISO 1182 or BS EN ISO 1716 and BS EN 13823

3.46 means of escape

structural means whereby a safe route (or routes) is (or are) provided for persons to travel from any point in a building to a place of ultimate safety

3.47 mixed-use building

building containing dwellings together with other types of occupancy and where the dwellings are not ancillary to the other use

3.48 open-plan arrangement

arrangement with open spatial planning, where the main living space is not separated from the dwelling entrance door

NOTE 1 The main living space refers to the lounge or living rooms.

NOTE 2 Bedrooms might or might not be separated from the main living space.

3.49 place of ultimate safety

place in which there is no immediate or future danger from fire

3.50 pressurization

method of protecting spaces against the ingress of smoke by maintaining a positive air pressure difference between the protected spaces and adjoining accommodation

3.51 protected circuit

electrical circuit protected against fire

3.52 protected corridor/lobby

circulation area consisting of a lobby or corridor enclosed with fire-resisting construction (other than any part that is any external wall of a building)

3.53 protected entrance hall/protected landing

circulation area consisting of a hall or space within the dwelling that is enclosed with fire-resisting construction

NOTE The protected entrance hall/protected landing does not include any external walls of a building.

3.54 protected stairway

stair discharging through a final exit to a place of ultimate safety (including any exit passageway between the foot of the stair and the final exit) that is adequately protected from fire elsewhere in the building by fire-resisting construction

- 3.55 residential care**
premises that offer institutional accommodation (suites of bedrooms) and personal care for people who might not be able to live independently
NOTE 1 Residential care is also known as care homes.
NOTE 2 Further guidance on housing definitions can be found in Table 1.
- 3.56 single stair**
common stair which is the only one to which dwellings in a block of flats or maisonettes have access
- 3.57 specialized housing**
accommodation that provides independent living for occupants who are wholly or mainly limited to a specific section of population and who are likely to require additional measures to secure their safety in the event of fire, including but not limited to accommodation provided for the elderly, children and people with a physical or mental impairment
NOTE Further guidance on housing definitions can be found in Table 1.
- 3.58 stay put strategy**
strategy normally adopted in blocks of flats and maisonettes whereby, when a fire occurs in a flat or maisonette, the occupants of that dwelling evacuate, but occupants of all other dwellings can safely remain in their dwellings unless directly affected by heat and smoke or directed to leave by the fire and rescue service
- 3.59 storey**
part of a building comprising all the rooms that are on the same level including any gallery having an area of more than half that of the space into which it projects, unless it is accessible only for maintenance or repair
- 3.60 storey exit**
final exit, or a doorway, giving direct access to a protected stairway or external escape route
- 3.61 travel distance**
actual distance a person needs to travel between two points within a building, having regard to the layout of walls, partitions and fittings

4 General recommendations

4.1 Basis of design

All fires generally start off small and can remain localized to the area around the point of ignition. Provided with sufficient fuel and ventilation, however, the potential exists for the fire to grow, and smoke and flames can spread to involve areas outside the immediate vicinity.

The recommendations and guidance given in this British Standard are based on the assumption that under normal circumstances (i.e. except in the case of arson) a fire is unlikely to start in two different places in a building at the same time (see 0.1) and, in the case of flats and maisonettes, a fire is most likely to start within the living space rather than in the common access routes or stairwells (see 0.8 regarding the importance of good fire safety management).

Initially the aim of these recommended fire precautions is to protect the occupants close to the origin of the fire, enabling them to reach a place of relative safety outside of the dwelling of fire origin and reducing their exposure to fire and smoke by raising the alarm and limiting travel distances. Where the fire safety measures that have been installed achieve their intended purpose, there is little risk to the other occupants of the building and simultaneous evacuation of the entire building is usually unnecessary.

Although unlikely, if:

- a) a dwelling entrance door fails to close; or
- b) a fire goes unreported (e.g. in an unoccupied dwelling) and increases to the point where containment to the dwelling of origin is threatened; or
- c) ignition does occur in the common parts; or
- d) there is a higher risk element associated with use of the building (e.g. ancillary accommodation or mixed-use buildings);

then it cannot be guaranteed that the common areas used for escape will remain completely unaffected, and further fire precautions are recommended for dealing with escape of occupants not immediately at risk but who might be required to escape at a later stage of fire development.

Measures are also provided where the primary user might have additional requirements to safely evacuate a building, such as in specialized housing, and to assist persons called upon to provide search and rescue operations and/or fire-fighting.

4.2 Variation of recommendations

The recommendations for means of escape in Section 2 permit variations to be made to travel distances on the basis that the level of risk can be reduced by the provision of additional fire protection measures. Such measures include the provision of:

- an additional level of automatic fire detection;
- a sprinkler system;
- an enhanced smoke management system.

Equally, the recommendations for designing the building structure in Section 4 and on fire-fighting in Section 8 permit certain variations when such measures as an automatic water sprinkler system (see Clause 11) are provided.

Designers and approving authorities are thus able to allow a degree of flexibility in the provision of fire safety measures as part of the overall design package, although there are set limits on the extent of variation permitted within the scope of this British Standard.

4.3 Property protection and business continuity

The recommendations and guidance in this British Standard are primarily concerned with the protection of life. The provision of fire safety systems for life safety does not necessarily give adequate protection to property (including personal possessions) or to business continuity.

Property protection and business continuity is equally important within the housing sector as in any other business activity. Businesses that provide housing should assess their business continuity arrangements and provide appropriate measures to mitigate the effects of fire. This could also include the potential societal loss of people's homes and the need for re-housing and care following a fire. This should be an integral part of the design stage of a building and should also include an assessment of the ongoing maintenance requirements of the building as well as an assessment of the fire protection needs during construction.

The potential for property and business loss should therefore be assessed so that such risks are understood and addressed. Such an assessment should be carried out in accordance with Annex B.

4.4 Environment

Many fires or emissions from combustion processes damage the environment. The contents of, and activities within, any building catching fire are likely to cause pollution to a greater extent than products used in the fabric of the building itself.

This British Standard is concerned largely with accidental fires, and the main area for consideration of the environmental impact of such fires is the loss of control of pollutants as a consequence.

Appropriate steps at the design stage of any building can minimize the impact of accidental fire on the environment and, whilst the emphasis is likely to be on the potential contents of the building, it would be responsible to consider the effects of using combustible materials in the building specification.

NOTE Fires that have been deliberately set might require additional measures to be taken which are outside the scope of this British Standard.

4.5 Atria

The primary objective with atria is to ensure that the incorporation of an atrium into a new or existing building does not present an increased risk to life as a result of fire and smoke spread.

This British Standard is concerned only with those additional measures that might be required to compensate for any increased risk resulting from the inclusion of an atrium within a building. It is not intended to provide a fire engineered solution for any particular design.

In atria, several storeys are contained in one volume. Atria are created by, for example:

- a) split-level floors;
- b) floors arranged as a spiral throughout the height of the building;
- c) balconies or gallery floors overlooking a central well or courtyard.

Atria can result in smoke and heat travelling readily throughout all levels of the building.

Atria should be designed in accordance with Annex C, using the occupancy category decision process given in Figure C.1 to determine whether the atrium building falls within the scope of this British Standard and, if it does, to determine a design solution.

NOTE The wide range of designs possible in atrium buildings makes it impossible for this British Standard to cover every conceivable scheme and its associated fire risk, therefore it deals only with atria up to a height of 18 m. A fire engineered approach is needed for atria in residential buildings over 18 m in height, and such designs are therefore outside the scope of BS 9991.

4.6 Inclusive design

Accessible means of escape, and the associated fire safety strategy, should be treated as an integral part of the design process, and not as a separate issue. Where a building is designed and managed inclusively to provide access for all users, the facilities provided should, where appropriate, be used to improve egress arrangements.

Special management procedures might be required where it is reasonably foreseeable that the proportion of disabled persons in a building will be relatively high. Recommendations for building management are given in Section 9.

NOTE Attention is drawn to the Equality Act 2010 [13] which places a duty on all employers and service providers not to discriminate against disabled people. It is vital to ensure that when making plans for the fire safety and management of buildings, the requirements of disabled people are properly taken into account at all times. It is important to note that the recommendations given in this British Standard are for escape not access. For example, certain dimensions might not provide suitable access for all people with impairments. Recommendations for access are given in BS 8300 and BS 9266, which explain how the built environment can be designed to anticipate, and overcome, restrictions that prevent people making full use of premises and their surroundings. BS 8300 gives recommendations for the design of buildings and their approaches to meet the needs of disabled people; BS 9266 gives recommendations for the design of accessible and adaptable housing.

Section 2: Designing means of escape

NOTE 1 Section 2 gives recommendations for means of escape in houses, flats and maisonettes. Some recommendations are common to all three and are given first. The recommendations that follow are specific, first for houses and then for flats and maisonettes.

NOTE 2 Recommendations for fire detection and fire alarm systems are given in Clause 10.

NOTE 3 Means of escape for atria are covered in Annex C.

NOTE 4 Methods of measurements such as floor heights, heights of buildings and fire and rescue service access are given in the Building Regulations 2010, Approved Document B [14]⁶⁾.

NOTE 5 Guidance on fire and safety signage is given in the Building Regulations 2010, Approved Document B [14].

5 General

5.1 Escape by way of doors and windows

Doors and windows that are to be used for means of escape or rescue should meet the following recommendations.

- a) Escape windows should have an unobstructed openable area that is a minimum of 0.33 m², having the minimum dimensions of 450 mm in height and 450 mm in width.

NOTE The route through the window may be at an angle rather than on a horizontal plane.

- b) The bottom of any openable area should be not more than 1 100 mm above the floor of the room in which it is situated.
- c) Doors and windows that are provided for escape or rescue purposes from a room above ground level should meet the following recommendations.
 - 1) If a window is a dormer window or a roof light, the distance from the eaves of the roof to the sill or vertical plane of the window or sill of the roof light should not exceed 1.5 m when measured along the roof.
 - 2) Any doors (including a French window or a patio window) should be guarded with a protective barrier in accordance with BS 6180.
 - 3) The ground beneath the window or balcony should be clear of any obstructions (such as iron railings or horizontally hung windows) and should be of a size and material that is suitable and safe for supporting a ladder.
 - 4) For security purposes many windows are kept locked with a key. Occupants should be advised to keep the key close to the escape window where it can be easily located.

A door or window should not face onto an internal shaft or enclosure unless escape to a place of ultimate safety is possible without re-entering the building.

⁶⁾ This British Standard contains multiple references to Building Regulations 2010, Approved Document B [14]. Guidance can also be found in the equivalent documents for use in Scotland [15] and Northern Ireland [16].

5.2 Escape from basements

COMMENTARY ON 5.2

In terms of means of escape, basements are similar to the upper levels of a house, where the further away they are from the entrance level, the greater the risk. Although the recommendations within this British Standard are not designed for external rescue from basements, it is recognized that buildings are safer where rescue might be possible. Basements are unlikely to have windows to facilitate rescue like the upper floors of a house. The measures applied can therefore be treated like the upper floors of a multi-storey dwelling.

Attention is drawn to the recommendations for fire-fighting access (50.1.2 and 50.1.3) and smoke clearance (14.2.1.3).

5.2.1 Houses

5.2.1.1 Single basement storeys

The basement storey of a dwelling provided with a single floor level below ground floor level should be provided with:

- a) an alternative escape route; or
- b) a protected stairway route via the ground floor leading to a final exit.

In either case the layout should be in accordance with one of the following options:

- 1) the total travel distance from any point of the basement to the foot of the stair should be limited to 9 m. Cooking facilities should be sited away from the internal escape route; or
- 2) a protected internal hallway from which all habitable rooms can be accessed should be provided, having a travel distance not exceeding 9 m from the foot of the protected stair to the door of any habitable room; or
- 3) all habitable rooms should be accessible from an internal hallway and an alternative exit should be provided from the basement; or
- 4) a line of fire separation, comprising 30 min fire-resisting construction, should be provided between the living and sleeping areas of the basement, and the basement should have an alternative exit from the bedroom area.

5.2.1.2 Multi-basement storeys

For dwellings with multiple floor levels below ground floor level, at least one of the following should be provided:

- a) an alternative exit from every level below ground. A line of fire separation, comprising 30 min fire-resisting construction, should be provided between the living and sleeping areas of the basement, and the basement should have an alternative exit from the bedroom area; or
- b) a protected stairway enclosure serving all habitable rooms and one alternative exit from each basement level; or
- c) a protected stairway and an LD1 fire detection and fire alarm system in accordance with BS 5839-6:2013. The maximum depth of the basement should be not more than 7.5 m below the entrance to the dwelling; or
- d) a protected stairway enclosure and an AWFSS (see 11.2, Table 2). The travel distance should not exceed 9 m from the foot of the protected stair to the door of any habitable room.

5.2.2 Flats

A basement flat that is not provided with its own external entrance at the level of the basement should be provided with an alternative exit (see 7.2).

NOTE General recommendations for flats are given in Clause 7 and Clause 9.

5.2.3 Other uses

Means of escape from basements that are designed to be ancillary to the dwelling use (e.g. parking garages) should be in accordance with BS 9999.

6 Means of escape and provision for rescue from houses

6.1 Single and two-storey houses

In single and two-storey houses the means of escape may be through the main entrance via the hall or alternatively through the window. Consequently, unless a protected escape route is provided, each bedroom should have a window in accordance with 5.1.

6.2 Inner rooms in houses

For houses, a habitable room should not be an inner room unless it is on the ground level or one floor above or below ground level and is provided with a door or window in accordance with 5.1 for escape or rescue purposes.

6.3 Houses with one floor more than 4.5 m above ground level

Houses with one floor more than 4.5 m above ground level should meet one of the following recommendations:

- a) the top storey or level of the house should be separated from the lower storeys by fire-resisting construction and should be provided with an alternative escape route leading to its own final exit; or
- b) the internal stairway should be constructed as a protected stairway, connecting the ground and all upper storeys; and either deliver directly to a final exit [see Figure 1a)] or allow access to at least two independent escape routes leading to alternative final exits [see Figure 1b)]; or
- c) where an open-plan arrangement exists at ground level, in order to separate the ground floor from the upper storeys, either:
 - 1) a protected stairway should be provided; or
 - 2) the house should be fitted throughout with an AWFSS (see 11.2, Table 2), together with a fire-resisting partition and door to separate the ground floor from the upper storeys. The fire-resisting door should be arranged such that occupants on the upper floors can access an escape window at first floor level, in accordance with 5.1, in the event of a fire in the open-plan area.

Figure 1 Alternative arrangements for escape via the ground storey in houses exceeding 4.5 m in height

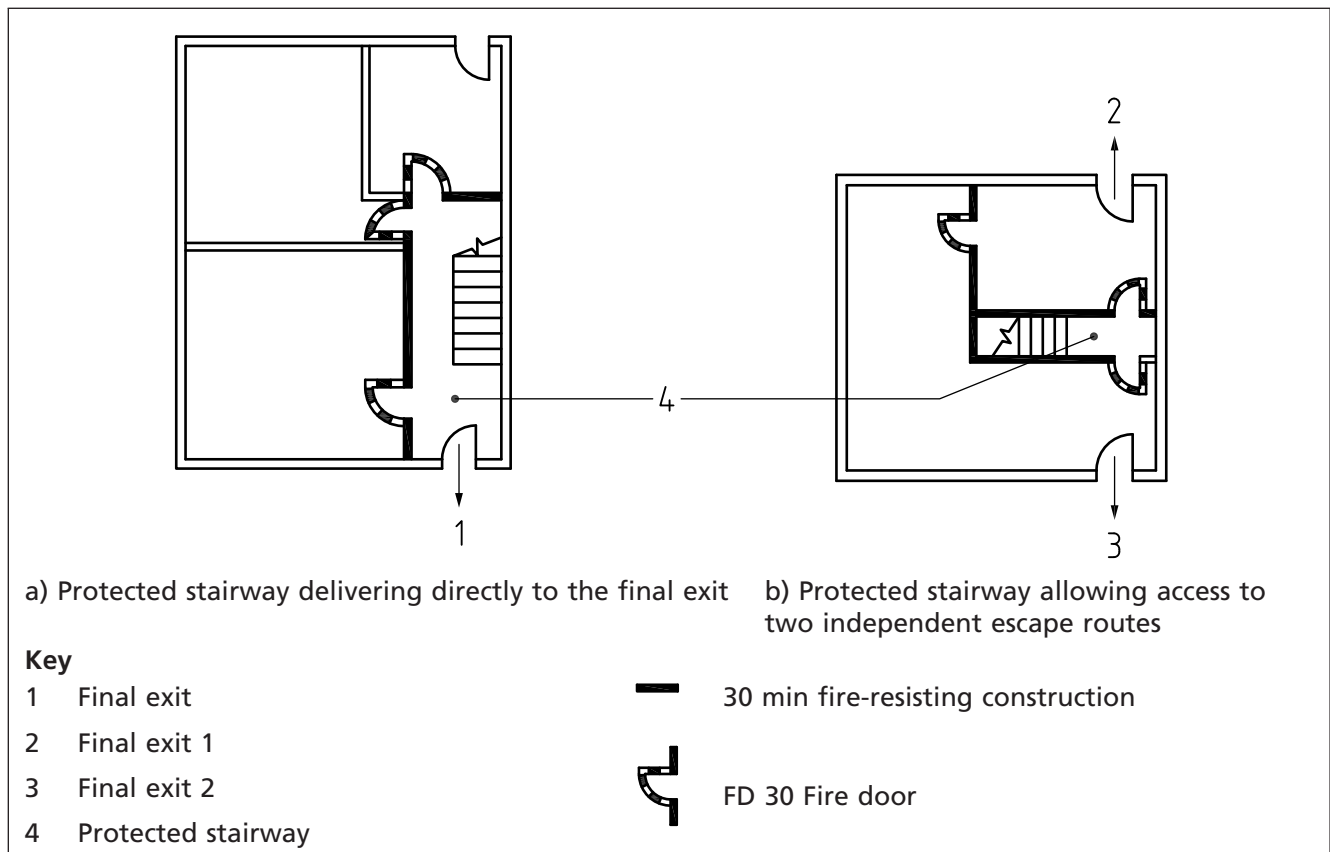

6.4 Houses with more than one floor higher than 4.5 m above ground level

Houses with more than one floor over 4.5 m above ground level should be in accordance with 6.3 and the following.

Each storey or level situated 7.5 m or more above ground level should have either:

- an alternative escape route; or
- a protected stairway and an AWFSS (see 11.2, Table 2) fitted throughout the house.

6.5 Loft conversions

Where a new storey is added by converting an existing roof space, provisions for escape should be protected throughout the full extent of the escape route.

A loft conversion to a two-storey house should have fire-resisting construction in the form of fire-resisting doors and fire-resisting partitions to protect the stairway.

This stairway should be protected at all levels and either:

- extend to the final exit; or
- allow access to at least two escape routes at ground level that are separated from each other by fire-resisting construction and fire doors.

Where an open-plan arrangement exists at ground level, one of the following should be provided:

- 1) a fire-resisting partition to enclose the escape route in accordance with 6.5a) or 6.5b); or
- 2) an AWFSS (see 11.2, Table 2) to the open-plan area, together with a fire-resisting partition and door to separate the ground floor from the upper storeys. This door should be arranged such that the occupants of the loft room are able to access an escape window in accordance with 5.1 at first floor level in the event of a fire in the open-plan area.

Houses having a floor level or a loft conversion higher than 4.5 m above ground level should be in accordance with 6.3 or 6.4, as applicable.

7 Means of escape from flats and maisonettes

COMMENTARY ON CLAUSE 7

The aim is to ensure that a fire which starts in any one dwelling does not obstruct the escape route of the occupants of any other dwelling. The planning of this part of the escape route depends on the number of common stairs serving the storey, the arrangement of the dwellings within the building and, in particular, the normal method of approach to dwellings having a common access (i.e. by an internal corridor or lobby or an external balcony or deck).

The provisions for means of escape for flats and maisonettes are based on the assumptions that:

- a) *the fire is likely to occur within a flat or maisonette rather than in the common areas;*
- b) *there is no reliance on external rescue (e.g. by portable ladder);*
- c) *the building is provided with a high degree of compartmentation and therefore a low probability of fire spread beyond the dwelling of origin, so that simultaneous evacuation of the building is unlikely to be necessary;*
- d) *although fires might occur in the common parts of the building, the materials and construction in those parts will prevent the fabric from being involved beyond the immediate vicinity; and*
- e) *escape routes enable a person confronted by an outbreak of fire to make a safe escape without outside assistance.*

To facilitate escape it might be necessary that common escape routes are safeguarded by some form of smoke control (see Clause 14).

The reliance of fire safety on manipulative apparatus, e.g. lowering lines or throw-out ladders, for means of escape, or on external rescue from the lower storeys of a building by the fire and rescue service using mobile ladders, is not advisable.

Recommendations for private and communal balconies are given in Annex D.

Guidance on live-work units is given in the Building Regulations 2010, Approved Document B [14].

7.1 General

Flats or maisonettes that are entered directly from outside the building at ground or access level should be treated as houses and should be in accordance with Clause 6 for the purposes of means of escape, instead of Clause 7.

Means of escape from small buildings should be in accordance with 7.5.

Enclosed private balconies serving a single dwelling should be treated as inner rooms and should be in accordance with Annex D.

Lifts should not be used for escape from fire unless an assessment shows that evacuation lifts are required. If evacuation lifts are to be installed, they should be in accordance with 8.4.

NOTE The misuse or malfunctioning of lifts can cause deaths, attributed amongst other things to failure of the power supply or from lifts being called to or held at the fire floor.

Where a fire alarm system covers the common areas and has a suitable electrical output signal, lifts other than fire-fighting and evacuation lifts should be recalled to an exit floor and then taken out of service in accordance with BS EN 81-73. Where there is no suitable fire alarm system, the lift should be recalled from a manual recall device in accordance with BS EN 81-73.

7.2 Alternative exits from flats and maisonettes

Alternative exits from flats and maisonettes should:

- a) be in accordance with the relevant recommendations of Clause 9 as appropriate to the type of building;
- b) be sited away from the main entrance door to the dwelling such that it can still be used as an escape route;
- c) be in accordance with the approaches illustrated in Figure 2, Figure 3, Figure 4, Figure 12 (see 9.4.2) or Figure 15 (see 9.4.3 and 9.4.4);
- d) lead to a final exit or common stair:
 - 1) via a door leading onto an access corridor, common balcony or deck at the same or another level; or
 - 2) via a protected stairway leading to an access corridor, common balcony or deck at another level; or
 - 3) via a door leading onto an external stair or a protected stairway; or
 - 4) via a door leading onto an escape route across a flat roof leading to the head of a common or external stair.

The internal arrangement of any dwelling having an alternative exit should be such that access is possible from all habitable rooms either to the main entrance or to the alternative exit. Fire-resisting separation should be provided, to safeguard the occupants who need to use the alternative exit.

NOTE It is not normally advisable to link balconies or install doors between dwellings to provide escape via a flat roof into an adjoining building.

7.3 Escape routes from flats and maisonettes with balcony approach or deck approach

In general there is little risk of a balcony or deck becoming smoke-logged and there is thus no need to impose a limitation on the travel distance from the dwelling entrance to the stairway, although account should be taken of the needs of the fire and rescue service, such as the distance between the nearest connection to a fire main and the flat or maisonette (see 50.1.3 and 51.1).

NOTE 1 Where an approach is via a balcony or deck having a width of more than 2 m, or via a balcony that is adjoined to the building wall only where there is an entrance to a flat or maisonette, there is a risk that the balconies might become smoke-logged both laterally along the balcony and upon levels above.

Where there is only a single direction of escape, provision should be made for the safety of persons who might have to escape past the flat or maisonette on fire (see Figure 5).

NOTE 2 In order to avoid impediment to means of escape, it is inadvisable to allow storage of any kind on the balcony or deck approach.

Escape routes should be in accordance with Figure 5.

Figure 2 Maisonette with alternative exits from each room not on the floor of entrance

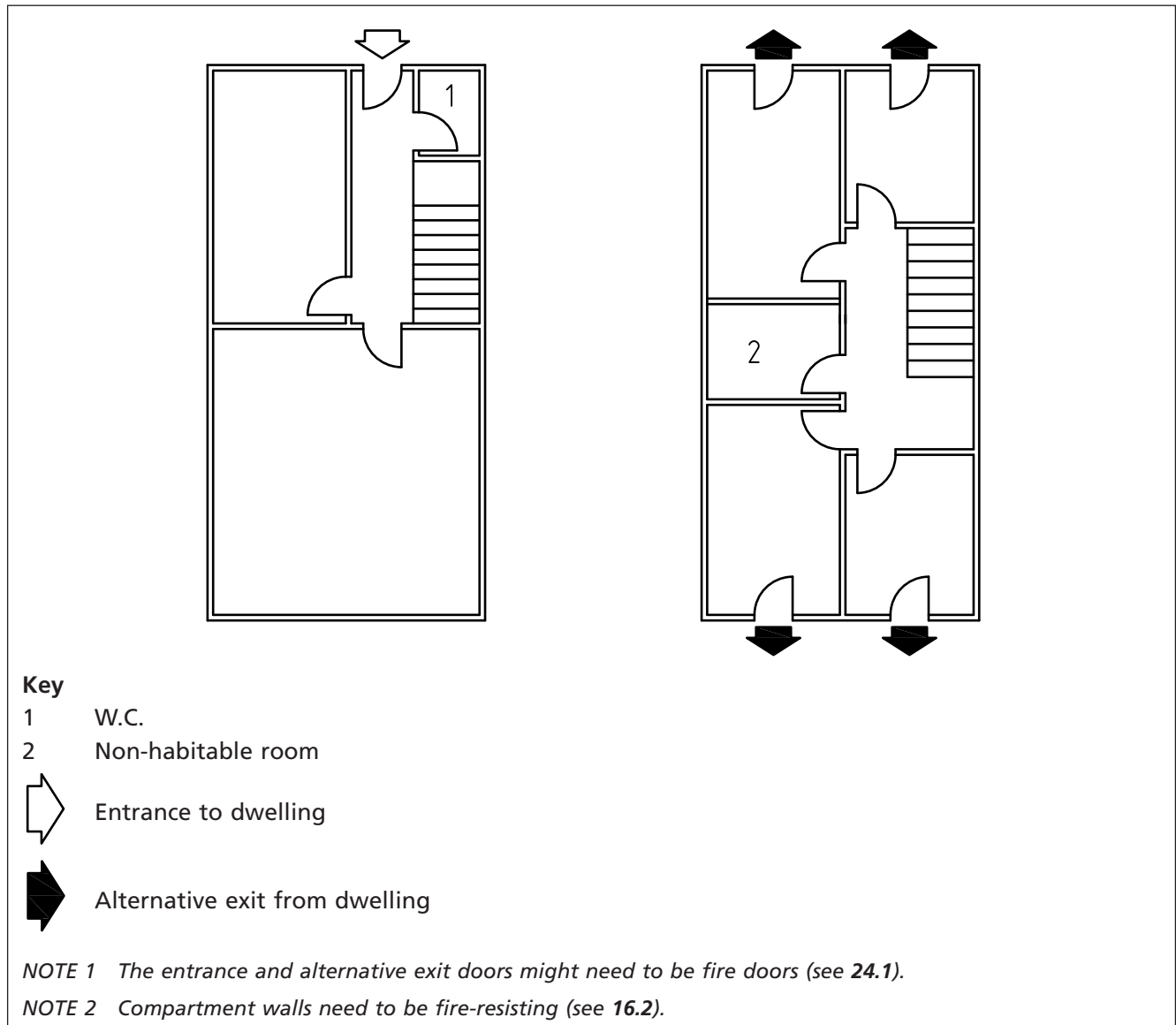

Figure 3 Maisonette with protected entrance hall and protected landing

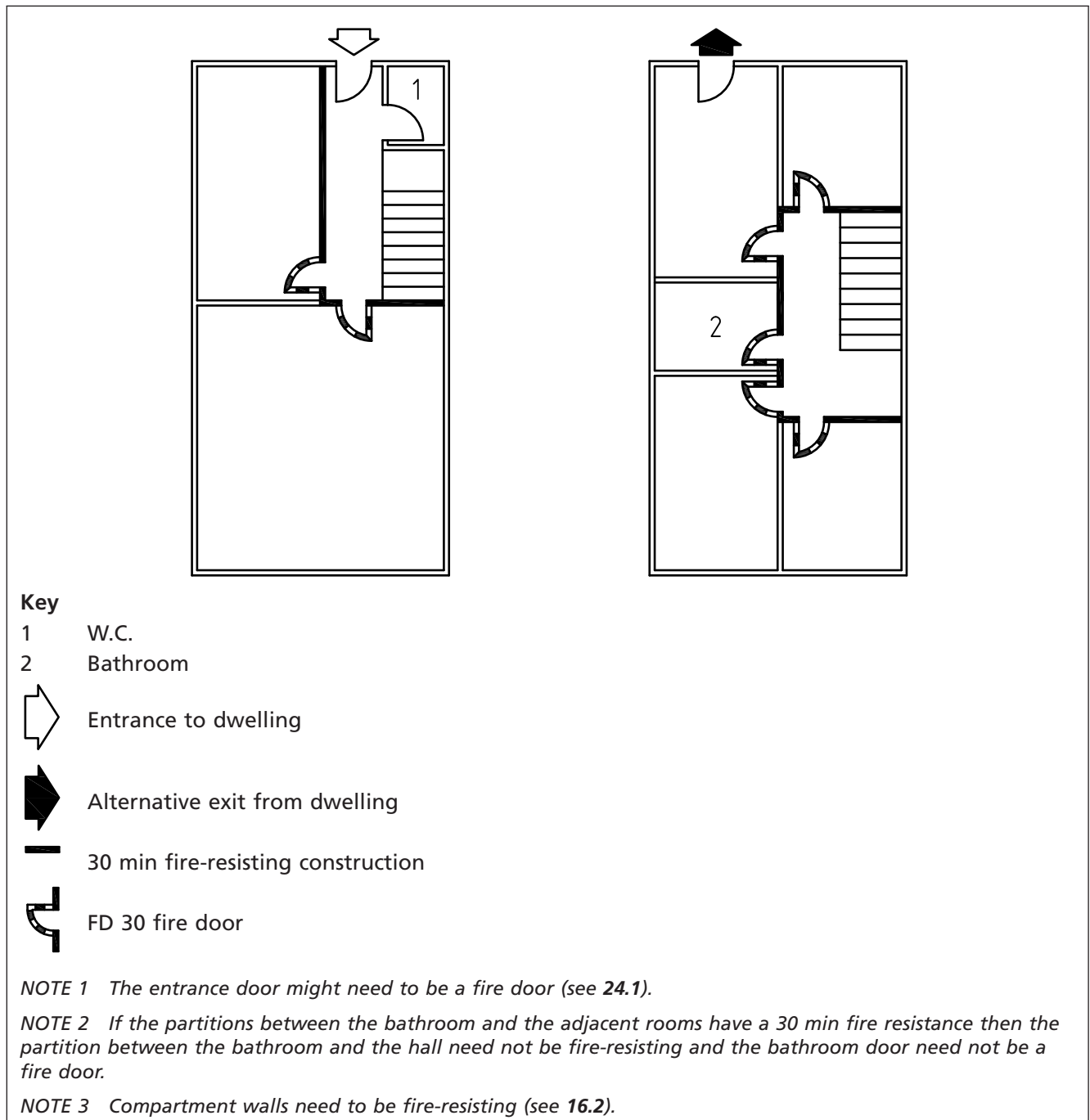

Figure 4 Open-plan maisonette

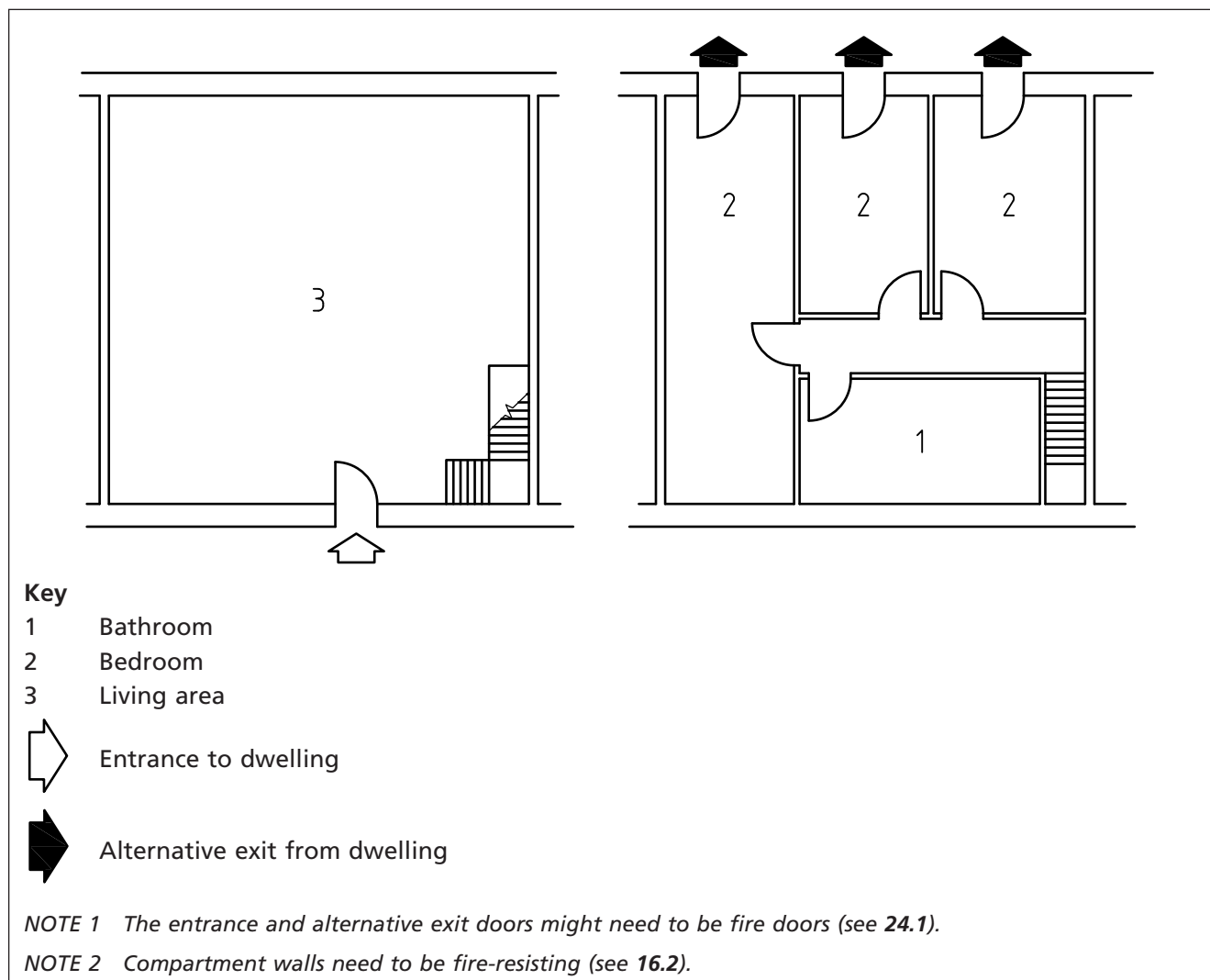
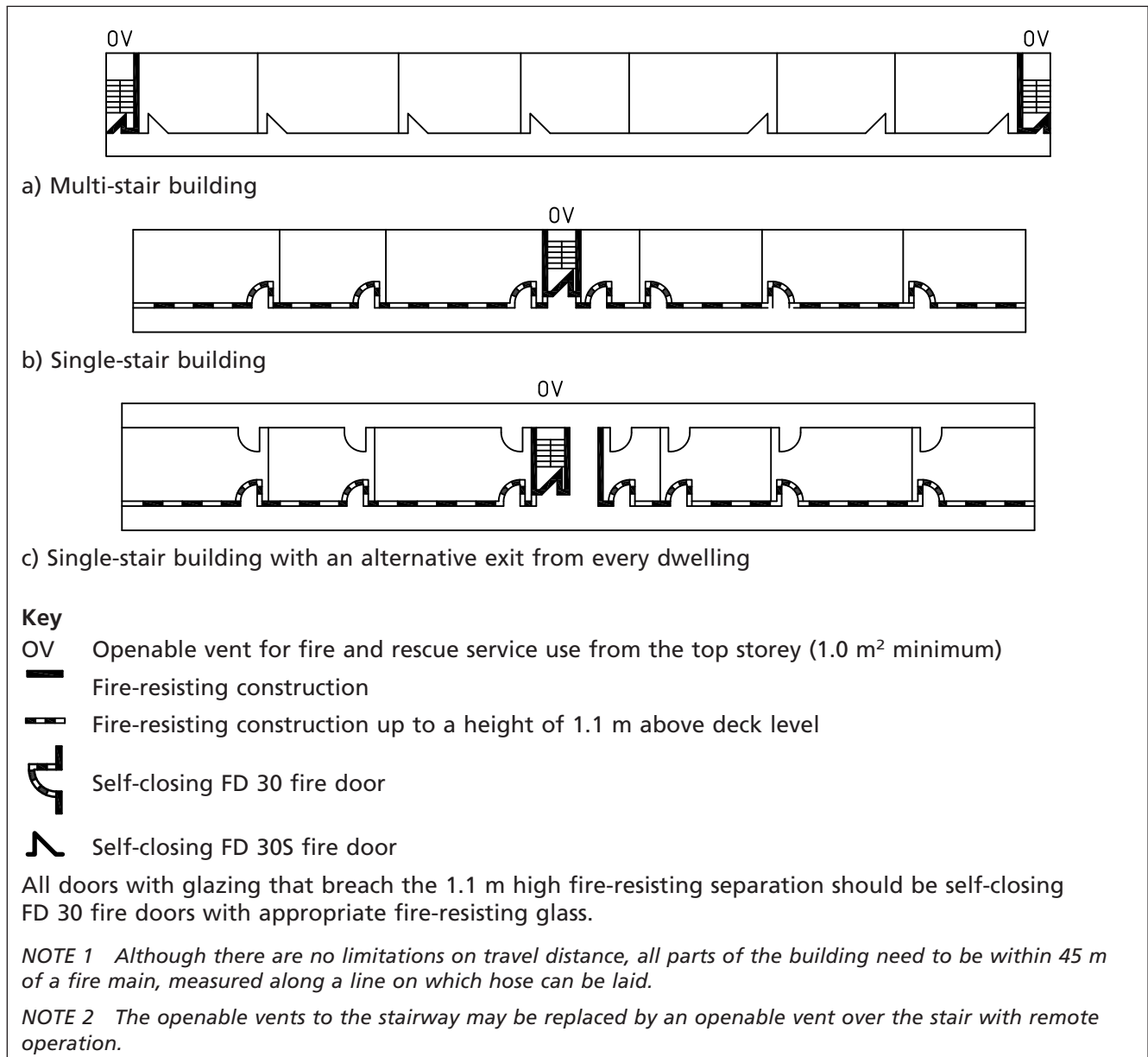

Figure 5 Common escape routes in balcony/deck approach buildings



Balconies and decks should meet the following recommendations.

- a) The structure, including the floor, should be protected by 30 min fire-resisting construction (integrity and insulation).
- b) The walking surface should be imperforate (i.e. there should be no holes or perforations in the structure so that users are protected from the effects of heat or smoke from below).
- c) The sectional profile should be such that any fire plume breaking out of a flat or maisonette is directed outwards and upwards, and should be arranged such that smoke does not leak laterally along the soffit. Balconies should be as open as possible to allow for the dispersal of smoke originating in a flat. At least 50% of the vertical section should be open and the area of opening should be uniformly spread around the surface. The opening for ventilation should be at least between the top of the balustrade at 1.1 m and the soffit to the balcony above.
- d) The soffit above a balcony or deck having a width of more than 2 m should be designed with down-stands placed at 90° to the face of the building (on the line of separation between individual flats or maisonettes). Down-stands should project 0.3 m to 0.6 m below any other beam or down-stand parallel to the face of the building, or should be determined by calculation.

NOTE 3 Suitable calculations are given in the BS 7346 series and BRE Report 368 [17].

- e) Where the balcony or deck is adjoined to the building wall only at the place where there is an entrance to a flat or maisonette, unless it is a minimum of 1.8 m away from the face of the building, it should, in the case of single direction escape routes, be proven by calculation that the escape route is not subjected to hazardous exposure levels or smoke-logging.

NOTE 4 Suitable calculations are given in the BS 7346 series and BRE Report 368 [17].

- f) Balconies providing a single direction of escape should be further safeguarded by the following provisions.
 - 1) The face of the building (excluding window openings) should provide at least 30 min fire resistance.
 - 2) Doors opening onto the balcony should be FD 30 self-closing doors.
 - 3) Window openings should not extend below a height of 1.1 m above the deck level.
 - 4) The external balustrade should be imperforate.
 - 5) Surface materials of the facing wall, balcony soffit and balustrade should be of a Class 0 rating.
- g) The length of balconies should be such that no point in any flat or maisonette is more than 45 m from a rising main landing valve or the approach position of a fire appliance (measured along the fire-fighting route of access).

7.4 Escape routes from flats and maisonettes with corridor or lobby approach

To prevent exposure of escaping occupants to smoke and heat in the internal corridor or lobby, either:

- a) the travel distance between the exit doors from the dwellings and a smoke-free area should be limited, and the amount of smoke and other combustion products in the internal corridor or lobby kept to a minimum by providing either cross-corridor fire doors and ventilation, or a mechanical smoke ventilation system; or

NOTE 1 Smoke control is covered in Clause 14.

- b) an independent alternative escape route should be provided from each dwelling either by way of a corridor at another level or through an external common balcony in accordance with 7.3.

NOTE 2 The options given in a) and b) allow designers of flats and maisonettes with corridor or lobby approaches some flexibility.

Where travel distances from the furthest dwelling entrance door to the means of escape staircase cannot be met then a mechanical smoke ventilation system and/or sprinkler and smoke ventilation system (see Clause 11, Table 2, 14.1.3 and Annex A) may be used to extend the travel distances.

For buildings not provided with a mechanical smoke ventilation system, escape routes should be provided in accordance with Figure 6 and Figure 7.

For buildings provided with a mechanical smoke ventilation system, escape routes should also be provided in accordance with Figure 6 and Figure 7, with the exception that cross-corridor fire doors and openable or automatically opening vents (AOVs) may be omitted.

7.5 Small buildings

Where a building does not have a storey at a height greater than 11 m and has no more than three storeys above ground storey and has a single stair, the following recommendations should be met.

- a) Escape routes should be provided in accordance with Figure 8.
- b) The stair should connect to a covered car park at ground level or above only if the car park is provided with permanent natural ventilation equivalent to 5% of the floor area of the car park, or is mechanically ventilated in accordance with BS 7346-7, and is separated by a protected, ventilated lobby (see 14.1.6).
- c) The stair should not serve ancillary accommodation unless the ancillary accommodation is separated from the stair by a protected lobby or corridor that is provided with permanent ventilation of not less than 0.4 m² for the control of smoke (see 14.1.6) or protected by a mechanical smoke ventilation system.
- d) Either:
 - 1) a high level openable vent should be provided at each floor level within the staircase enclosure with a minimum free area of 1 m²; or
 - 2) a single openable vent which can be remotely operated from fire and rescue service access level should be provided at the head of the stair; or
 - 3) an AOV should be provided at the head of the stair.

NOTE For connection to basement levels, see 30.2.

Figure 6 Common escape routes in single stair buildings with a floor level more than 11 m above ground

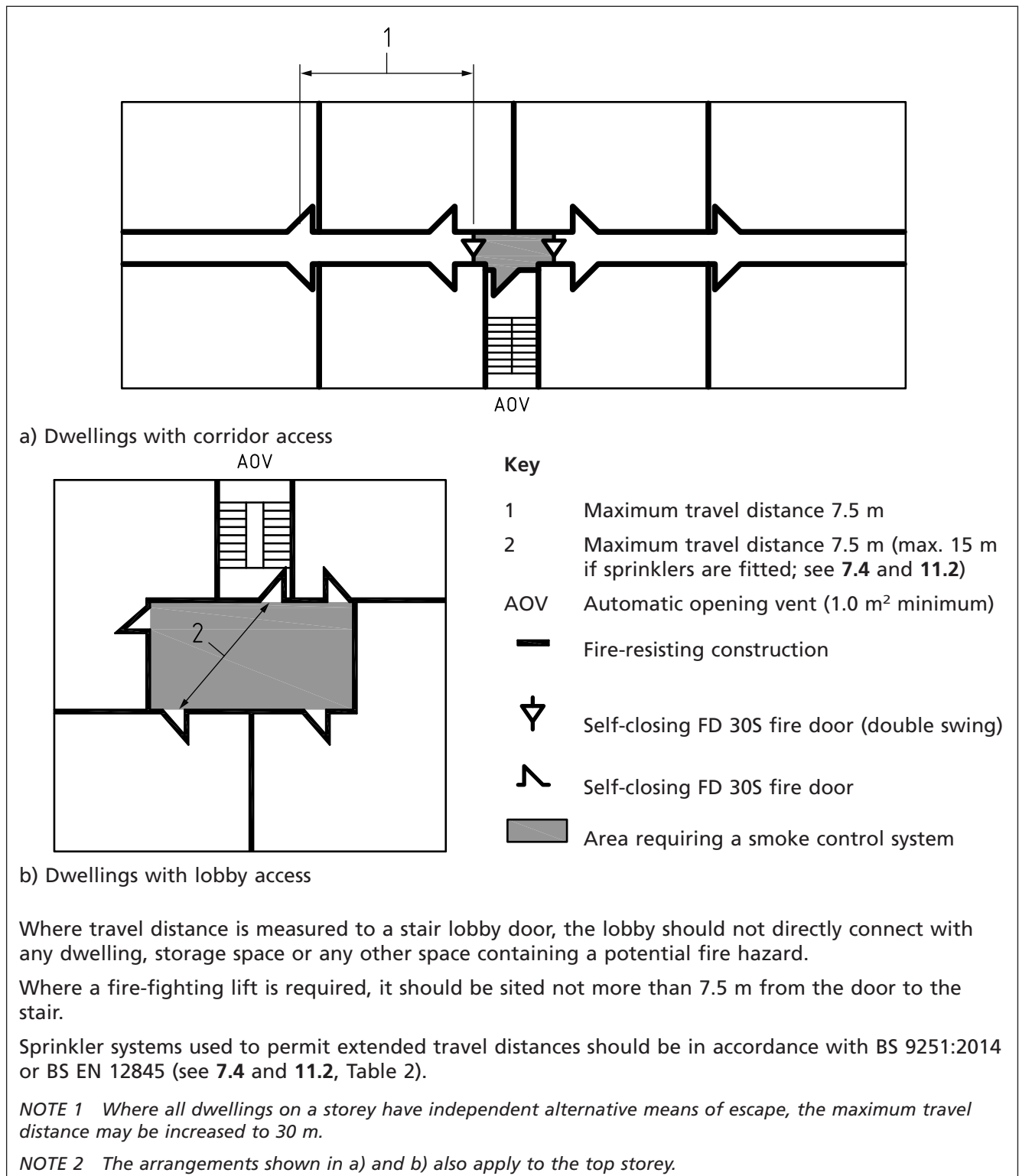
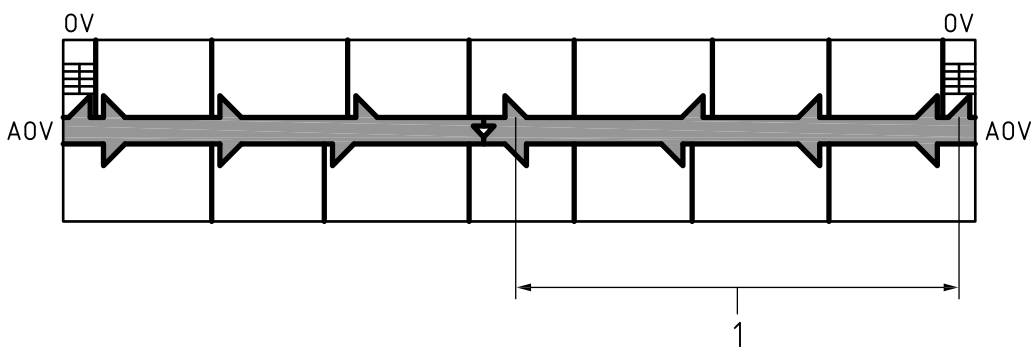
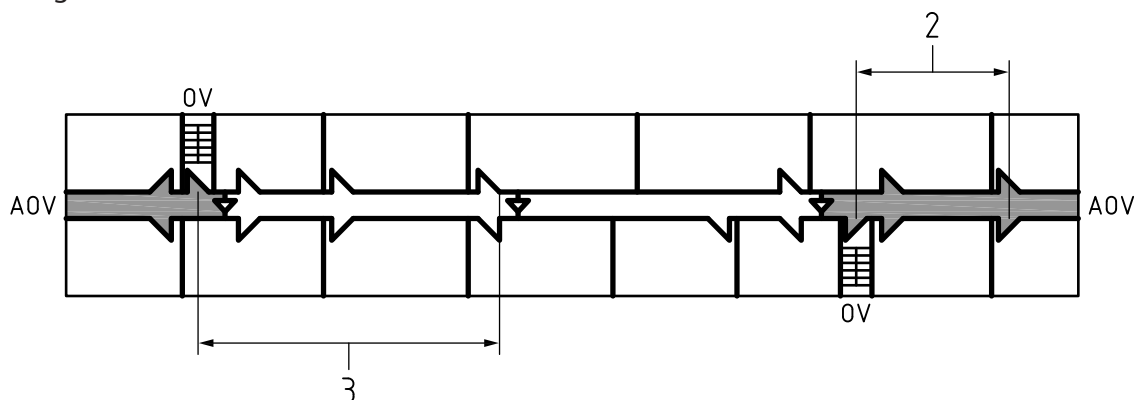

Figure 7 Common escape routes in multi stair buildings



a) Dwellings with corridor access and without dead ends



b) Dwellings with corridor access and with dead ends (see Note 1)

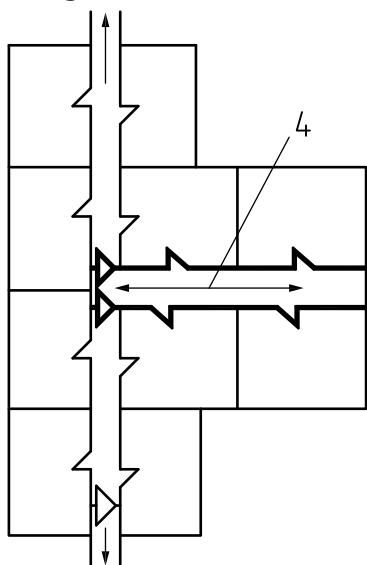

c) T junction with main corridor

Key

- 1 Maximum travel distance 30 m (max. 60 m if sprinklers are fitted; see 7.4 and 11.2)
- 2 Maximum travel distance 7.5 m (max. 15 m if sprinklers are fitted; see 7.4 and 11.2)
- 3 Maximum travel distance 30 m
- 4 Maximum travel distance 7.5 m
- AOV Automatic opening vent (1.5 m² minimum)
- OV Openable vent for fire and rescue service use (1.0 m² minimum)
- Self-closing FD 305 fire door (double swing)
- Self-closing FD 305 fire door
- Area requiring a smoke control system

Sprinkler systems used to permit extended travel distances should be in accordance with BS 9251:2014 or BS EN 12845 (see 7.4 and 11.2, Table 2).

NOTE 1 The central fire door may be omitted where the maximum travel distance does not exceed 15 m.

NOTE 2 Where all dwellings on a storey have independent alternative means of escape, there are no limitations on travel distance. All parts of the building, however, need to be within 45 m of a fire main, measured along a line on which hose can be laid.

NOTE 3 The openable vents to the stairway may be replaced by an openable vent over the stair.

NOTE 4 The arrangements shown also apply to the top storey.

Figure 8 Common escape routes in small single stair buildings

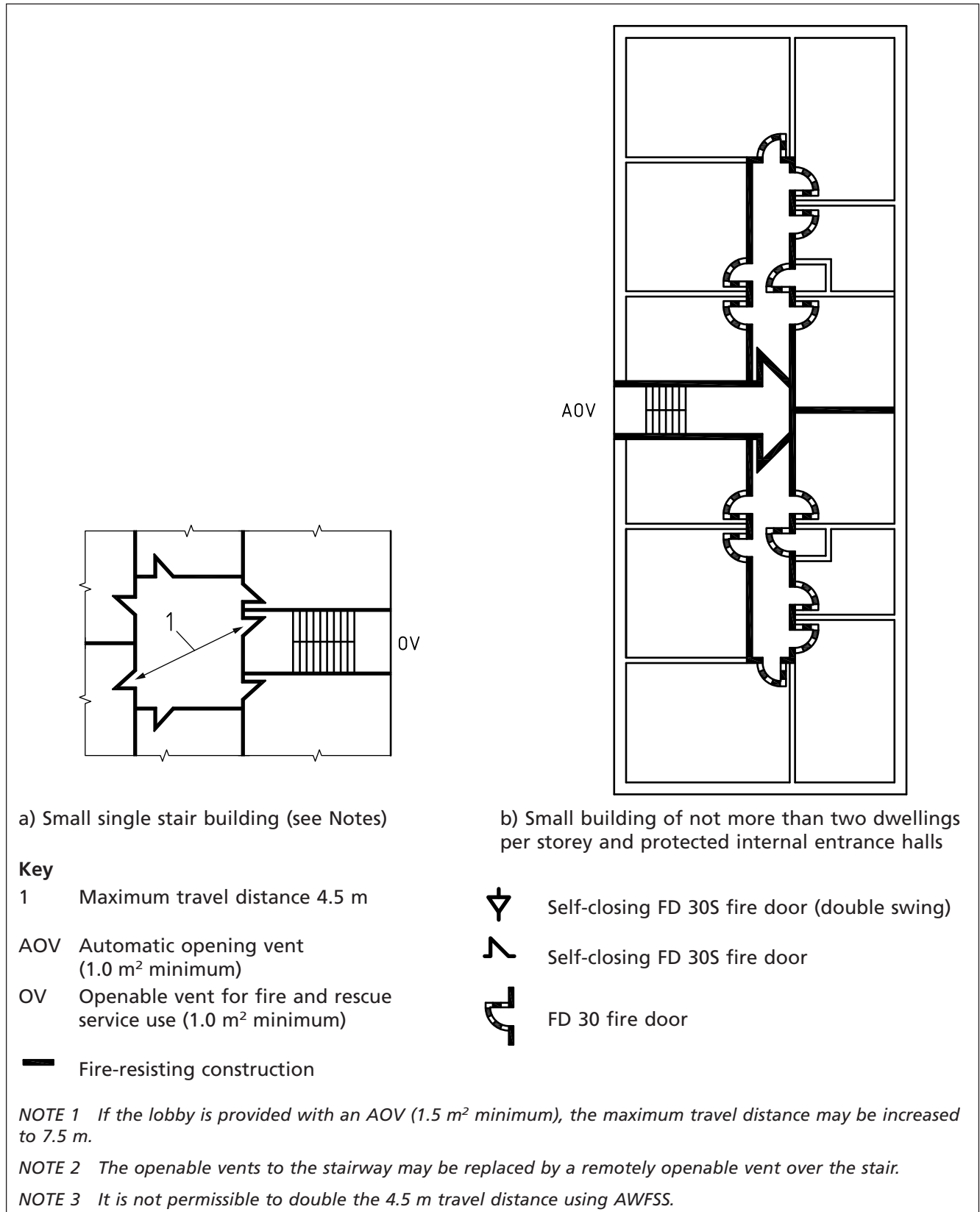

8 Means of escape from specialized housing

8.1 General

Accommodation that does not need an onsite manager service should be designed as self-contained flats in accordance with all the appropriate recommendations given in this British Standard.

For accommodation with a warden/scheme manager service or with specialist support, the recommendations given in 8.2 to 8.7 should be met in addition to the applicable general recommendations for self-contained flats given in this British Standard.

The level of fire precautions provided within specialized housing should be determined following an assessment of both the level of need of the intended residents and the design features of the building, including its size, height, and the internal layout of flats.

8.2 Travel distances

Where occupants are not capable of independent evacuation from their flat without external assistance, the protected stairway enclosures and protected corridor layouts, incorporating fire subdivisions as necessary, should be planned and constructed such that no person would have to travel more than 7.5 m from the flat entrance door along a corridor or lobby before reaching a fire door accessing either a protected stairway enclosure or another protected corridor zone.

Internal travel distances within accommodation, where occupants are not capable of independent evacuation from their flat, should be limited to 9 m, or an alternative exit should be provided that is suitable for the abilities of the occupants.

NOTE See also Clause 10 and Clause 11 for recommendations on fire detection and automatic fire suppression systems.

8.3 Protected stairways and corridor zones

For all specialized housing accommodation types, when deciding on the dimensions of protected stairways and corridor zones, provision should be made for adequate refuge space for occupants to await further progressive evacuation in managed buildings.

NOTE 1 This may include the provision of refuges in accordance with BS 9999.

NOTE 2 This might have to include space for more than one wheelchair, which is dependent on the building occupancy.

8.4 Vertical transportation

Account should be taken of the numbers of residents who would need assistance to evacuate vertically. Where it is deemed necessary to assist vertical evacuation, sufficient evacuation lifts should be provided to meet travel distance and vertical escape recommendations. The lift should be in accordance with the relevant provisions for evacuation lifts given in BS 9999.

Where an ordinary passenger lift is to be used for the evacuation of disabled people, the appropriate recommendations given in BS 9999 should be carried out to assess the suitability of a particular lift.

Where evacuation lifts are installed, these should be clearly signed at the final exit storey and relevant information should be available detailing the locations of the main switch, rescue controls and machinery spaces.

8.5 Furnished areas in corridors

Furniture may be provided within common corridors in accordance with Figure 9 where there is on-site management control. Furniture should not be provided anywhere in dead-end corridors.

Where furniture is provided in communal areas, it should conform to the medium hazard resistance to ignition classification specified in BS 7176. Curtains in communal areas should meet the performance requirements for classification as Type B or Type C when tested in accordance with BS 5867-2:2008.

Figure 9 Furnished areas in specialized housing corridors

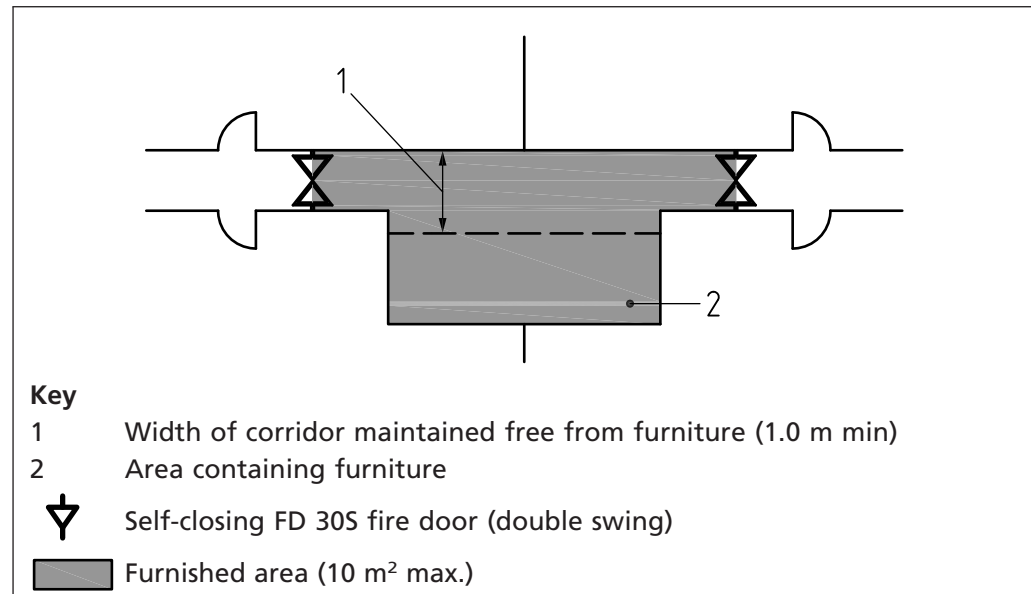

8.6 Doors

The needs of the occupants should be assessed, and the appropriate door closing devices and other door hardware should be selected and installed.

NOTE Where self-closing doors might present an obstacle to the occupants of the building, then free swing door closers and hold-open devices within circulation spaces conforming to BS EN 1155 might be appropriate.

8.7 Electric wheelchairs and mobility scooters

Provision should be made for the storage and charging points associated with electric wheelchairs and scooters.

Where an area has been designated for storage of electric wheelchairs and scooters within the building, this area should be separated from the means of escape by fire-resisting construction of not less than 30 min. Electric charging points could introduce a fire risk into areas through which occupants might need to make their escape and as such should not be located in common access corridors or protected stairways.

9 Internal planning of flats and maisonettes

COMMENTARY ON CLAUSE 9

Clause 9 is concerned with the safety of occupants within their dwellings. The aim is to ensure that a fire that starts in a dwelling will not prejudice the escape of the occupants of that dwelling. The recommendations for the internal planning of a dwelling depend on whether it is a flat or maisonette, its size, whether it is situated at or close to ground level and whether it has an independent final exit.

There are several ways of providing safe escape routes: through the provision of an alternative exit (see 7.2); by ensuring that the escape route from any habitable room is by way of a protected entrance hall within which no likely source of fire exists, and within which the travel distance is limited; or by the limitation of the travel distance from any point in the flat to the flat entrance door.

These constraints are unnecessary in the case of ground floor flats entered from outside the building and for flats situated above the ground floor provided with their own external entrance at ground level. Similar considerations apply to flats entered from a podium deck.

9.1 General

Cooking facilities in open-plan flats or maisonettes should be located in such a way that they do not prevent escape if they are involved in a fire.

Flats or maisonettes having an independent external entrance at ground or access level should be treated in the same way as those having corridor or lobby access.

Flats or maisonettes having more than one storey and not having an independent external entrance at ground or access level should:

- a) have an alternative exit from each habitable room that is not on the entrance floor of the dwelling; or
- b) have one alternative exit from each floor (other than the entrance floor), with a protected landing entered directly from all the habitable rooms on that floor; or
- c) where the vertical distance between the floor of the entrance storey and the floor above and the floor below it does not exceed 7.5 m, provide a protected stairway and a Grade D LD1 fire detection and fire alarm system in accordance with BS 5839-6:2013; or
- d) have a protected stairway and an AWFSS (see 11.2, Table 2).

9.2 Basement flats

Any habitable room in a basement flat should not be an inner room, unless the room is provided with a door or window conforming to 5.1 for escape purposes.

NOTE Basement flats can be open-plan flats (see 9.7).

9.3 Flats or maisonettes situated not more than 4.5 m above ground or access level

Any habitable room should not be an inner room unless the room is provided with:

- a) a door or window conforming to 5.1 for escape purposes; or
- b) a Grade D LD1 fire detection and fire alarm system in accordance with BS 5839-6:2013 and an AWFSS (see 11.2, Table 2) installed throughout the building (see also 9.7).

9.4 Flats situated more than 4.5 m above ground or access level

9.4.1 General

Flats that are situated more than 4.5 m above the ground or access level should be in accordance with 9.4.2, 9.4.3 or 9.4.4, as applicable.

9.4.2 Flats entered on the same level as the flat

Flats having an entrance on the same level as the flat should meet one of the following recommendations:

- the total travel distance from any point of the flat to the entrance door of the flat should be limited to 9 m. This limit may be extended to 20 m if an AWFSS (see 11.2, Table 2) and an LD1 fire detection and fire alarm system in accordance with BS 5839-6:2013 are installed. Cooking facilities should be sited away from the flat entrance door and the internal escape route (see Figure 10); or
- a protected internal hallway should be provided that leads off to all habitable rooms having a travel distance not exceeding 9 m from the flat entrance door to the door of any habitable room (see Figure 11); or
- all habitable rooms should be accessible from an internal hallway and have an alternative exit from the flat [see Figure 12a)]; or
- a 30 min fire-resisting construction should be provided between the living and sleeping areas of the flat and an alternative exit from the bedroom area should also be provided [see Figure 12b)].

Figure 10 Flat with restricted travel distance

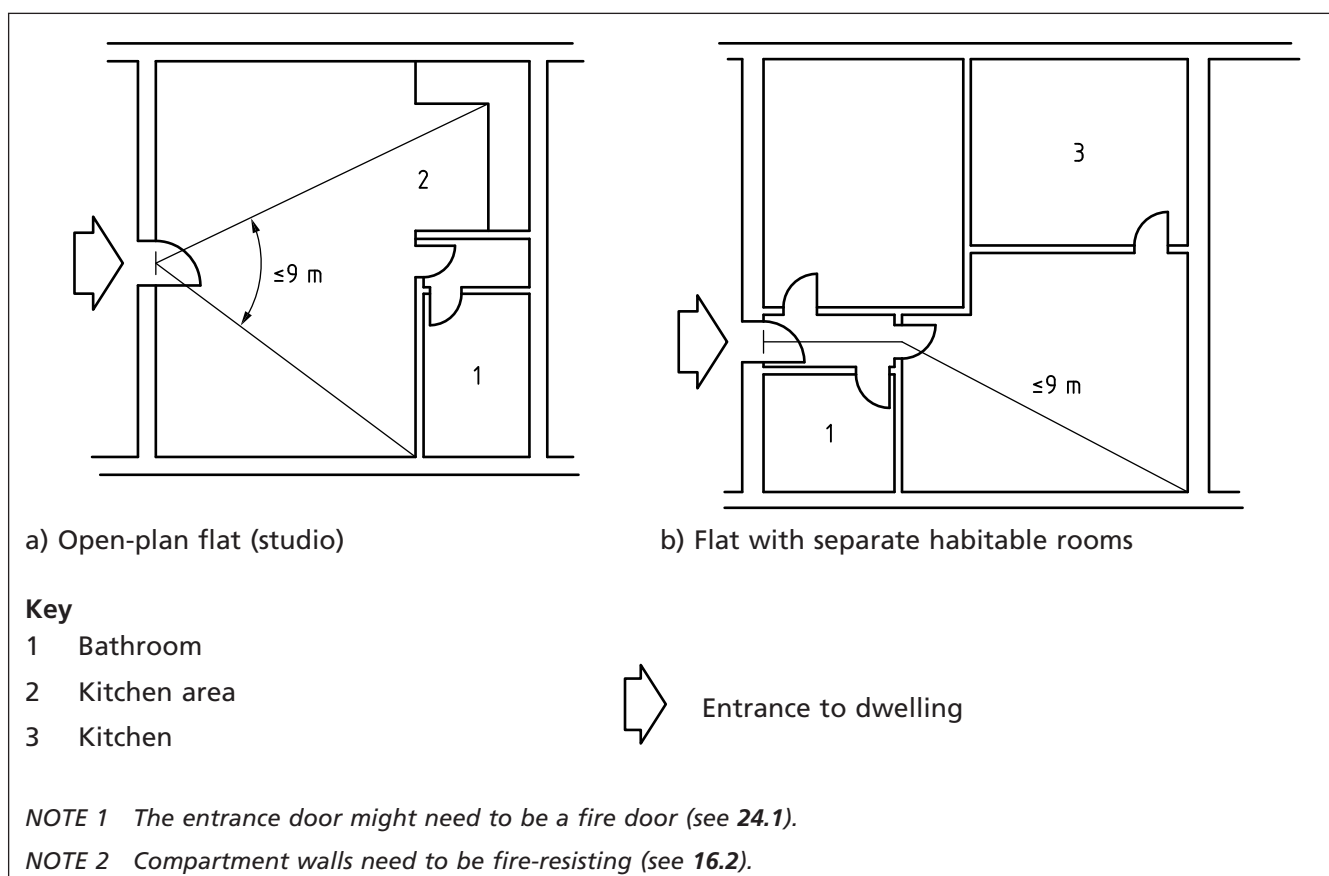

Figure 11 Flat with a protected entrance hall and restricted travel distance

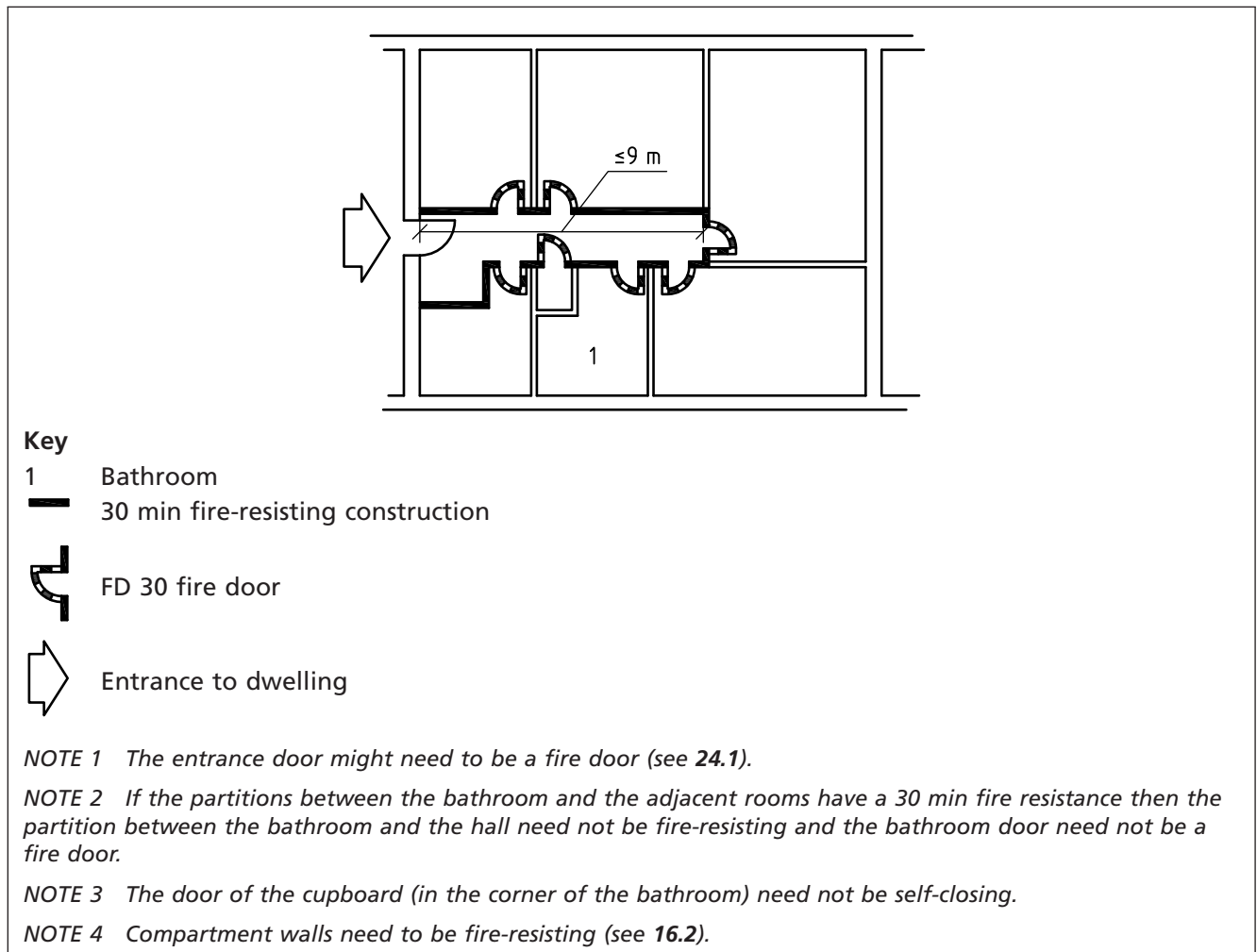
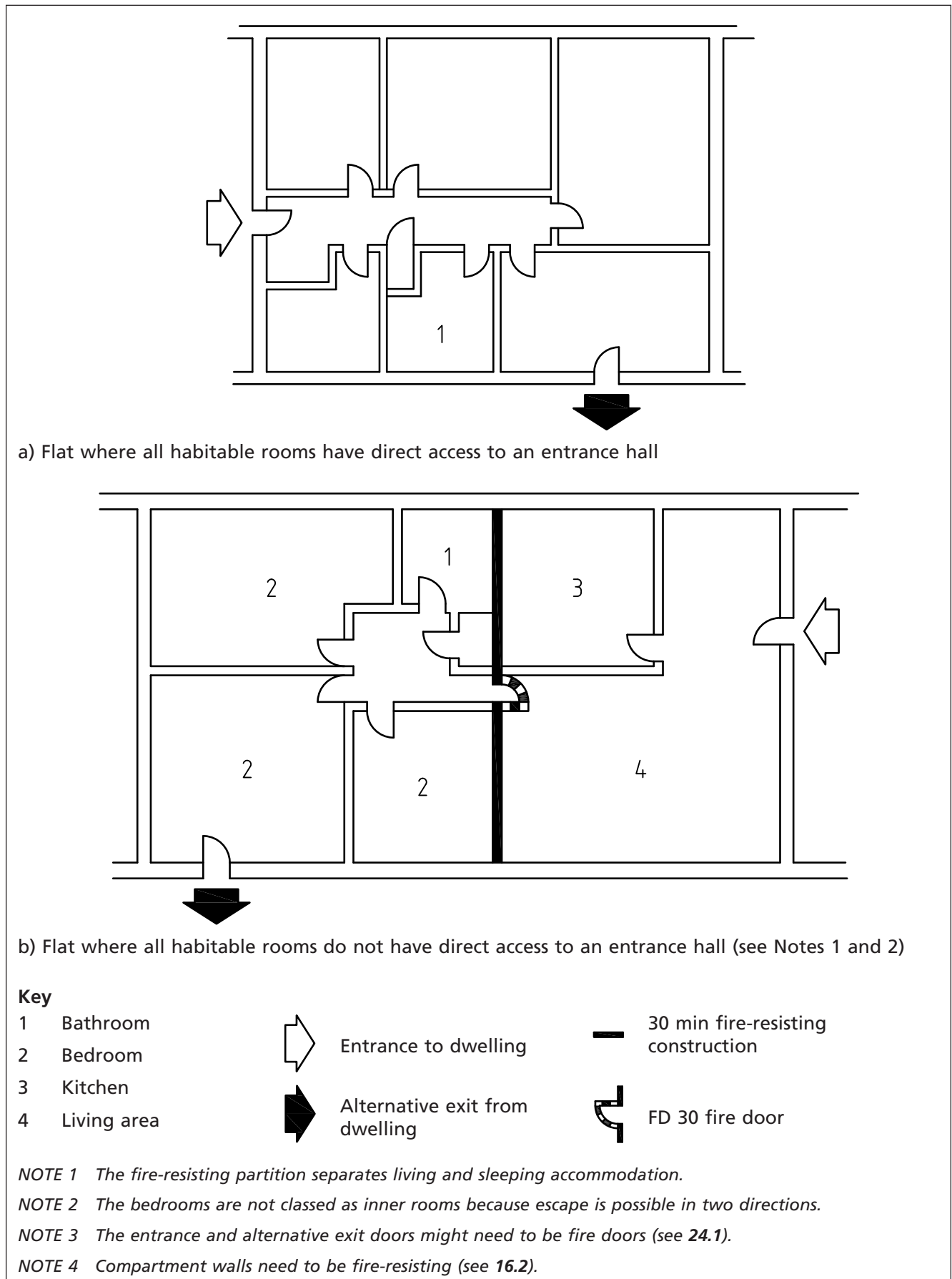

Figure 12 Flat with an alternative exit



9.4.3 Flats entered from a floor below the flat

Flats with the entrance on a floor below the flat should meet one of the following recommendations:

- a) the total travel distance from any point of the flat to the head of the stair should be limited to 9 m. This limit may be extended to 20 m if an AWFSS (see 11.2, Table 2) and an LD1 fire detection and fire alarm system in accordance with BS 5839-6:2013 are installed. Cooking facilities should be sited away from the flat entrance door and the internal escape route (see Figure 13); or
- b) a protected internal hallway from which all habitable rooms can be accessed should be provided, having a travel distance not exceeding 9 m from the top of the stair to the door of any habitable room (see Figure 14); or
- c) all habitable rooms should be accessible from an internal hallway and an alternative exit should be provided from the upper floor of the flat [see Figure 15a)]; or
- d) a line of fire separation should be provided between the living and sleeping areas of the flat and there should be an alternative exit from the bedroom area [see Figure 15b)].

9.4.4 Flats entered from a floor above the flat

Flats with the entrance on a floor above the flat should meet one of the following recommendations:

- a) an alternative exit should be provided from the bedroom area of the lower floor level. Where habitable rooms do not have direct access to an enclosed hallway or landing, fire-resisting construction and fire-resisting doors should separate the living and sleeping areas (see Figure 15); or
- b) a protected internal stairway and hallway or landing should be provided together with a Grade D LD1 fire detection and fire alarm system in accordance with BS 5839-6:2013.

9.5 Internal planning of maisonettes

9.5.1 Maisonettes having no floor level higher than 4.5 m above ground or access level

Maisonettes that do not have a floor level that is situated higher than 4.5 m above the ground level or the access level may be treated as houses for internal planning purposes (see 6.1 and 6.2).

9.5.2 Maisonettes having a floor level higher than 4.5 m above ground or access level

Maisonettes that have a floor level that is situated higher than 4.5 m above the ground level or the access level should have at least one of the following:

- a) an alternative exit from any habitable room that is not on the entrance level of the maisonette (see Figure 2); or
- b) a protected stairway enclosure serving all habitable rooms and one alternative exit from every floor level other than the entrance level (see Figure 3); or
- c) a protected stairway enclosure and an LD1 fire detection and fire alarm system in accordance with BS 5839-6:2013, if no floor is more than 7.5 m above or below the level of the entrance of the maisonette; or
- d) a protected stairway enclosure and an AWFSS (see 11.2, Table 2).

Figure 13 Flat (entered from below) with a restricted travel distance

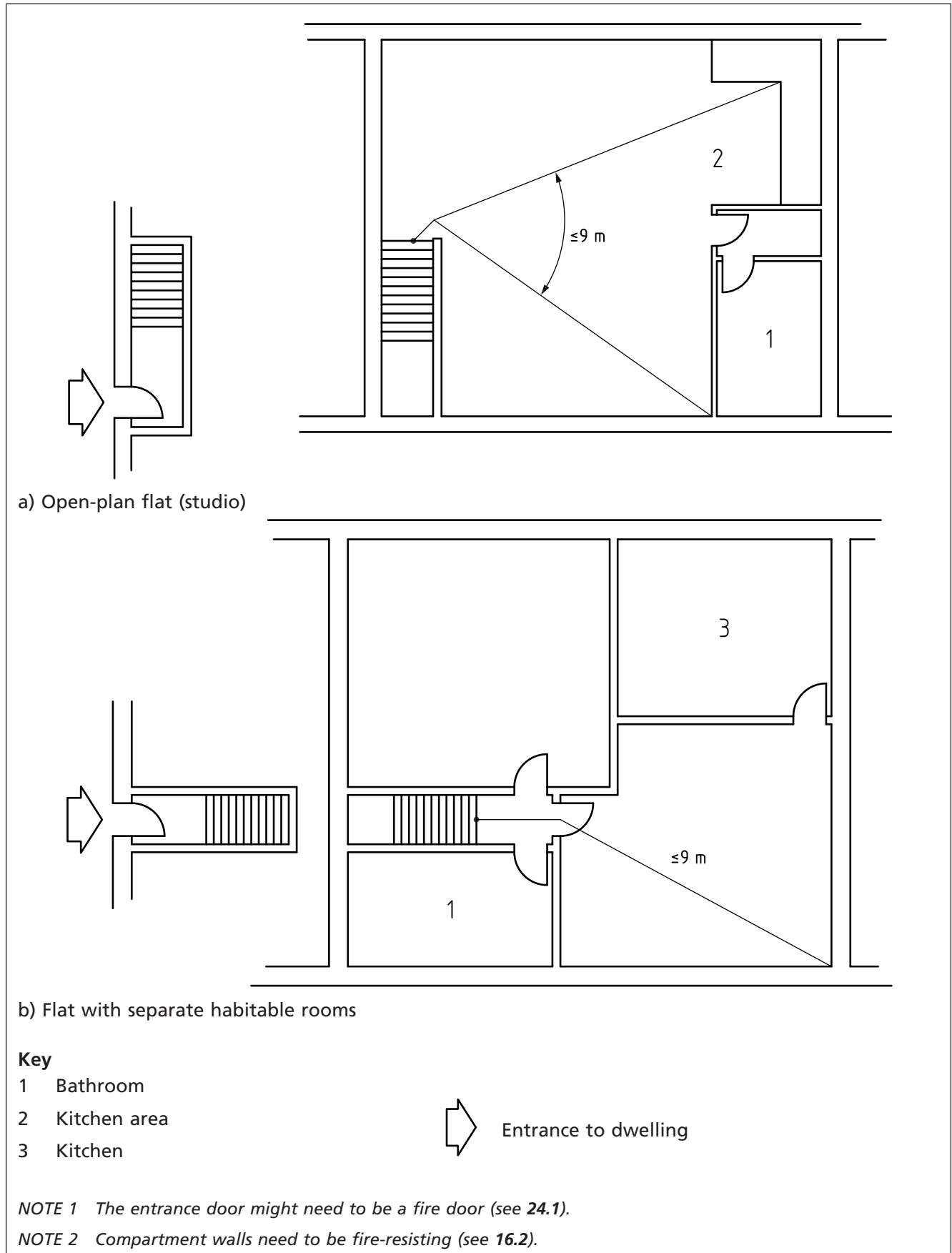

Figure 14 Flat (entered from below) with a protected entrance hall and restricted travel distance

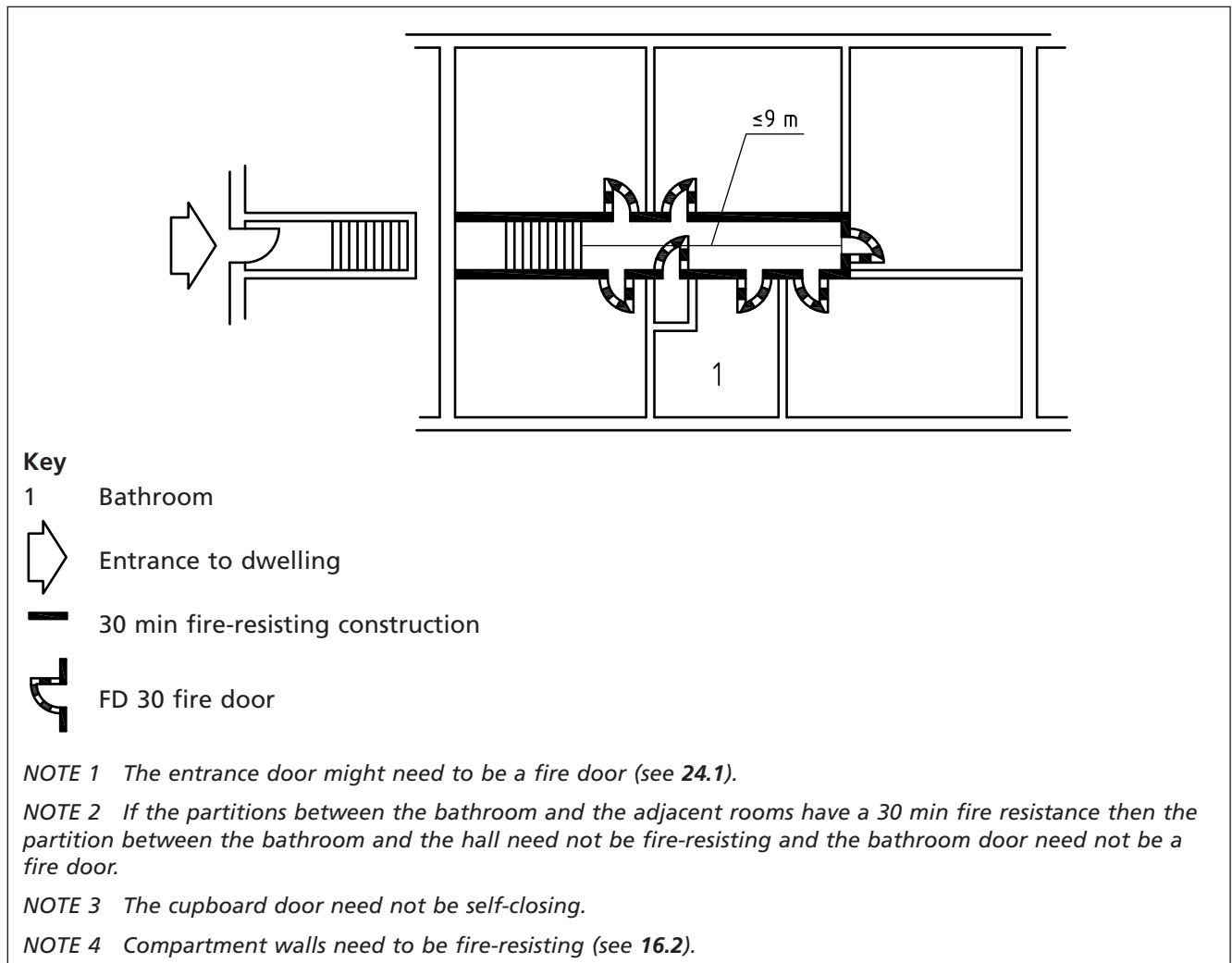
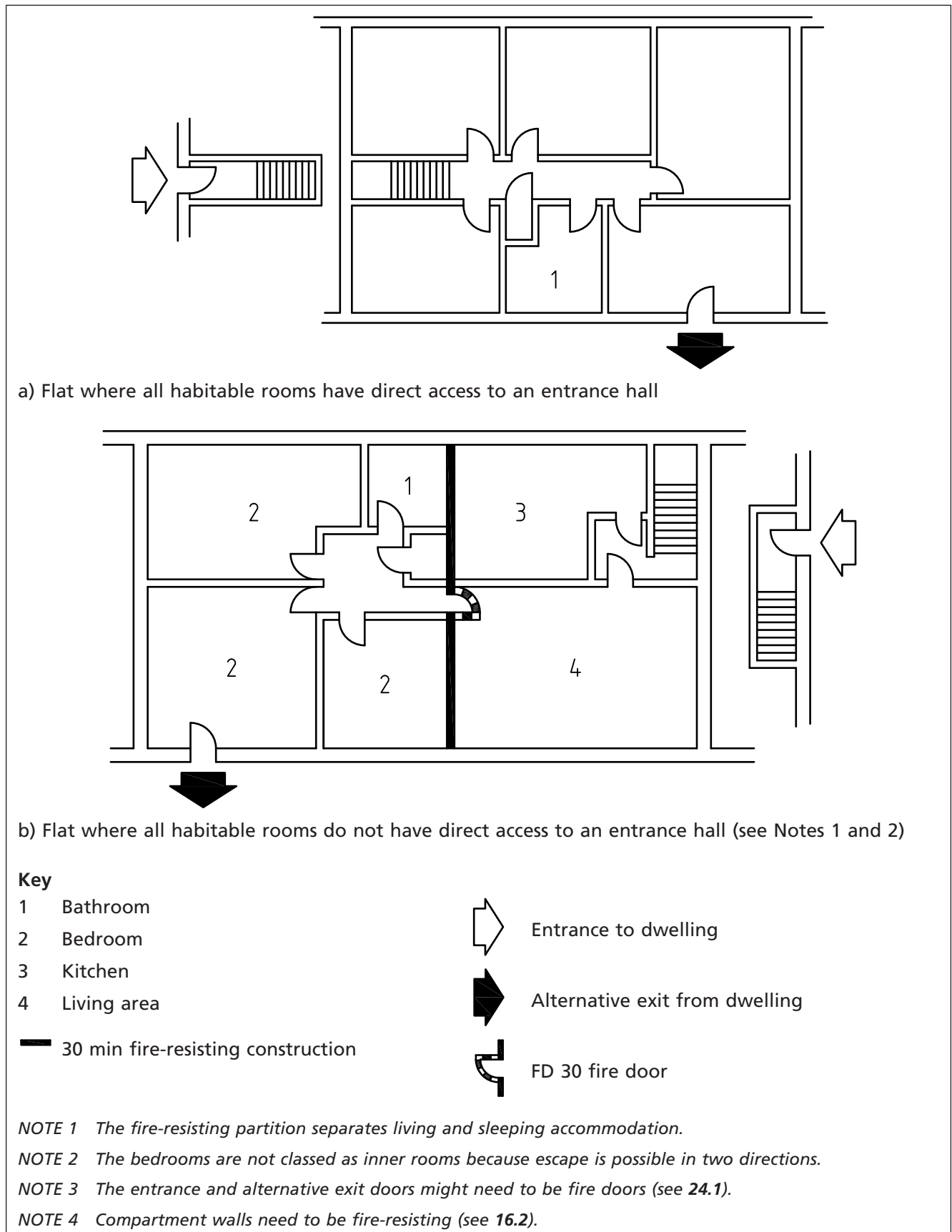

Figure 15 Flat (entered from above or below) with an alternative exit



9.6 Flats with galleries

Flats with galleries should meet the following recommendations.

- a) To be classed as a gallery, the gallery should overlook at least 50% of the area of the room below.
- b) The main level of the flat should be planned and constructed in accordance with Figure 11 or Figure 12, as applicable.
- c) Any cooking facilities within a room containing a gallery should, where practicable, be enclosed with fire-resisting construction. Where cooking facilities are not enclosed with fire-resisting construction, they should be sited away from the escape route from the gallery or from the flat.
- d) The distance from the foot of the access stair to the gallery and the entrance door of the flat or a door leading to a protected entrance hall should not exceed 3 m.
- e) Where the travel distance from the head of the access stair to the gallery to any point in the gallery exceeds 7.5 m, an alternative exit should be provided from the gallery.
- f) Where the gallery exceeds 50% of the area of the floor below, the gallery should be treated as an inner room.

9.7 Open-plan flat design

Open-plan flat layouts should not be provided for accommodation where the occupants are not capable of independent evacuation.

Open-plan flats that do not have protected corridors or hallways but have bedrooms that are inner rooms without having an alternative means of escape, and that are accessed directly from a lounge or similar type accommodation, should be fitted throughout with a Grade D LD1 fire alarm and fire detection system in accordance with BS 5839-6:2013, and an AWFSS (see 11.2, Table 2).

Open-plan flats should meet the following specific recommendations.

- a) The size of the open-plan flat should not exceed 16 m × 12 m.
- b) Open-plan flats should be situated on a single level only.
NOTE 1 Single level flats exclude flats with galleries.
- c) The ceilings within the open-plan flat should have a minimum height of 2.25 m.
- d) The kitchen should be enclosed in open-plan flats having an area exceeding 8 m × 4 m. Cooking appliances in open-plan flats having an area smaller than 8 m × 4 m should not be adjacent to the entrance of the flat.

NOTE 2 An open-plan flat design is not compatible with small, single staircase buildings reliant upon internal protected entrance halls for lobby protection to the staircase enclosure.

9.8 Cluster accommodation

COMMENTARY ON 9.8

Clusters of flats are a common arrangement found in purpose-built modern student accommodation. They are similar in layout to flats but often have more bedrooms and no living spaces apart from a shared kitchen. A typical cluster accommodation layout is shown in Figure 16. Studio flats are not considered to be suitable for cluster accommodation and are to be treated as flats (see 9.4.2). For HMOs, refer to 0.3 for guidance.

Figure 16 Typical cluster accommodation layout

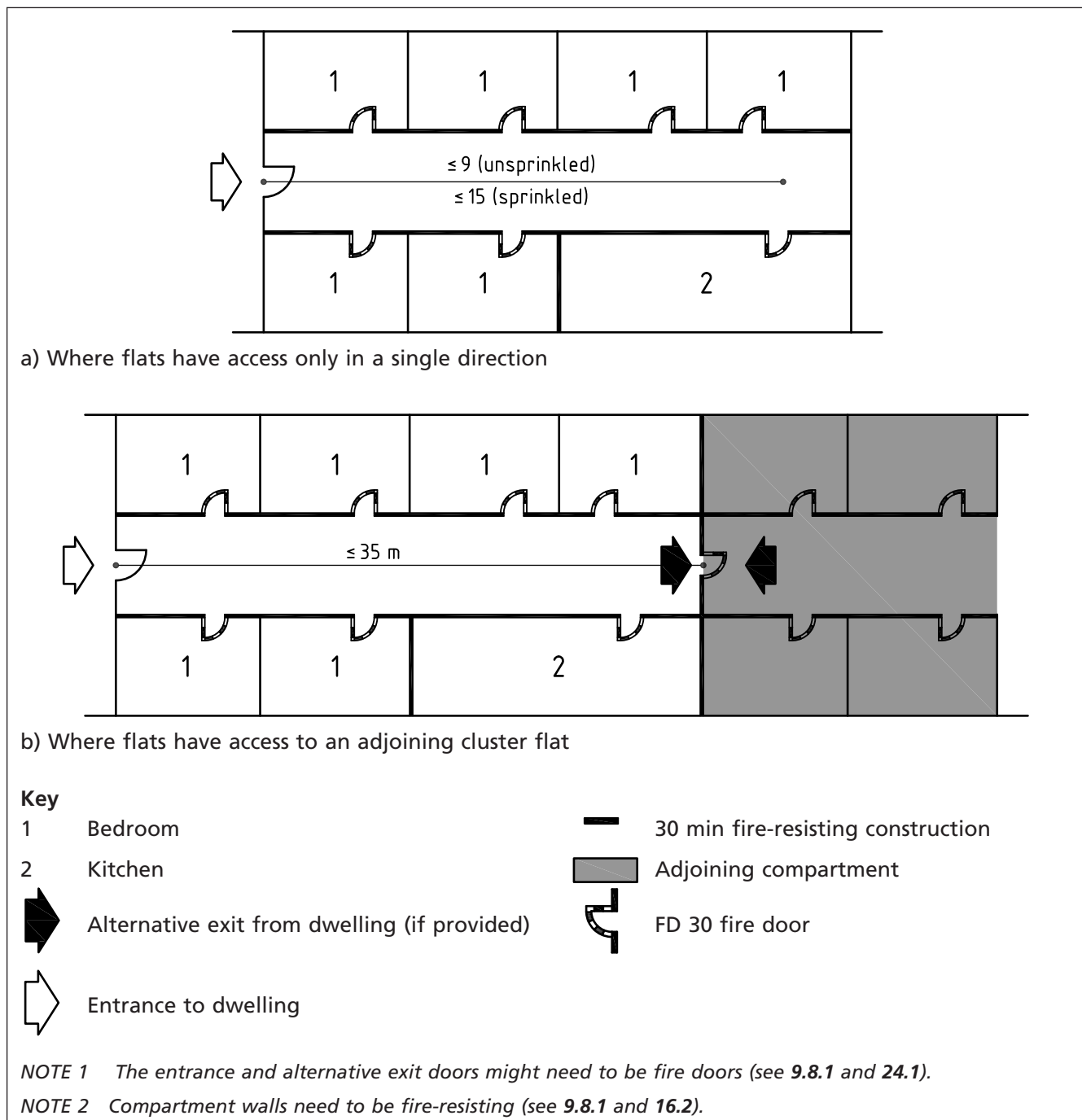

9.8.1 General

The common areas of cluster accommodation should be in accordance with the general recommendations for flats given in this British Standard.

A cluster should be separated from the remainder of the building by construction having at least 60 min fire resistance and an FD 30S fire door. The internal corridor serving the rooms of the cluster should have at least 30 min fire resistance to each room off the corridor.

The doors to the bedrooms and living spaces accessed from the protected corridor should be FD 30S and self-closing. Cupboard and service duct access from the corridor should be separated by FD 30S fire doors.

There is no limit to the number of bedrooms within a cluster, as long as the travel distances within the internal corridor of each individual cluster are no more than 9 m in a single direction and no more than 35 m where escape is possible in more than one direction. The 9 m travel distance may be increased to 15 m in a single direction where sprinklers in accordance with BS 9251:2014 or BS EN 12845 (see 11.2, Table 2) are installed throughout the cluster.

Cross-corridor doors should be provided at around the midpoint of a corridor where two escape routes are proposed and the internal corridor length exceeds 15 m.

The cluster should be lobbied from any staircases serving the building (i.e. a protected lobby should be formed between the cluster front entrance door and the stair door).

A fire detection and fire alarm system should be provided in accordance with BS 5839-6:2013, LD1 or BS 5839-1:2013, L1, as applicable, for simultaneous evacuation of the cluster of fire origin.

A smoke detector should be provided in each habitable room and a heat detector should be provided in the kitchen.

A link to the fire alarm and detection system should be provided to the management responsible for the building if it is staffed 24 h per day, or to a remote monitoring centre.

9.8.2 Kitchens in cluster accommodation

Kitchens in clusters should be separated from any bedrooms by construction having at least 30 min fire resistance.

Kitchen doors should be provided with self-closing devices, which may be held open by an electromagnetic door holder linked to the detection system.

Kitchens should be located at the remote end of the corridor away from the final exit to the cluster.

Section 3: Active fire protection

10 Fire detection and fire alarm systems

10.1 General

A fire detection and fire alarm system designed and installed in accordance with BS 5839-6:2013 should be provided in all dwellings, in order to warn occupants of fire within the dwelling and to provide them with time to evacuate the premises and to call the fire and rescue service.

It might be appropriate for some common areas, e.g. lounges or communal roof gardens, to be provided with a fire detection and/or fire alarm system. This should be determined based on the extent and use of these common areas, the fire risk and the management response available. Where a fire detection and/or fire alarm system is required, it should be provided in accordance with BS 5839-1:2013.

Where rapid summoning of the fire and rescue service is considered critical to the safety of occupants (e.g. on the basis of a fire risk assessment), facilities should be provided for the automatic transmission of alarm signals to an alarm receiving centre, unless there are reliable arrangements for summoning the fire and rescue service by persons in the building. Automatic transmission should also be provided if occupants are mobility impaired to a degree that would cause them to be at high risk in the event of fire, or if there is any reason to suspect that occupants would be unlikely or unable to alert the fire and rescue service.

Where fire detection systems are required in areas other than individual dwellings, e.g. to activate smoke control systems, a system conforming to BS 5839-1:2013 should be installed.

Where warning devices are installed in specialized housing, they should cater for the applicable sensory conditions and therefore should be compatible with specialist devices such as vibrating alerters, visual alarm devices, etc. Warning devices should also allow for supplementation where personal emergency evacuation plans (PEEPs) dictate a particular need.

10.2 Automatic fire detection and fire alarm systems for mixed-use buildings

Where any part of a mixed-use building is expected to have non-residential occupancy groups, the occupancy groups should be separated by fire-resisting construction and have independent escape routes, with the exception of certain small buildings (see Clause 31). Each type of occupancy should be provided with the appropriate fire detection and fire alarm system in accordance with the relevant part of BS 5839.

Where flats are part of a building containing different occupancy groups, the fire detection and fire alarm system should be designed in accordance with the relevant part of BS 5839 to facilitate the evacuation and management strategy appropriate for that building. In small mixed-use buildings (see Clause 31) which share a common escape route, the flats should have individual fire detection and fire alarm systems in accordance with BS 5839-6:2013, and the other occupancy (or occupancies) should have a fire detection and fire alarm system in accordance with BS 5839-1:2013. These alarms do not need to be interlinked.

11 Automatic fire suppression systems

COMMENTARY ON CLAUSE 11

Automatic fire suppression systems are designed to detect a fire and automatically release an extinguishing agent to extinguish the fire or prevent its spread.

Water is the most common extinguishing agent, as used in sprinkler systems and watermist systems. Individual sprinkler and watermist components react to heat to release water onto the fire below.

11.1 General

All buildings with a floor higher than 30 m above ground should be fitted with sprinklers in accordance with BS 9251:2014 or BS EN 12845 (see 11.2, Table 2).

Where the proposed use of the building requires accommodation to be provided for occupants who are not capable of independent evacuation, the relevant flats and common areas (excluding common corridors and staircases) used by such occupants should be provided with an AWFSS (see 11.2, Table 2).

11.2 Permitted variations

With the exception of accommodation provided for occupants who are not capable of independent evacuation from their flat (see 11.1), where a block of flats is fitted with a sprinkler system in accordance with BS 9251:2014 or BS EN 12845 (see Table 2), the maximum travel distance for escape in the ventilated section of common corridors in one direction only may be increased from 7.5 m to 15 m, and for escape in more than one direction it may be increased from 30 m to 60 m.

NOTE 1 The extension of travel distances is not permitted in the unventilated sections of common corridors.

Where it is permissible within this British Standard to vary the fire safety provisions by installation of an AWFSS, the specific systems and categories given in Table 2 should be used. Where the building has several requirements for the provision of AWFSS, the most onerous category or hazard classification given in Table 2 should be applied.

NOTE 2 The hazard categories for sprinkler systems are based on the risks: Category 1 is typically provided where the risks are present solely to the occupants of the dwelling of fire origin, rather than adjoining occupants, and Category 2 is provided where the occupants of more than one dwelling or the fire service could be affected. Table 2 gives recommendations, additional to the guidance given in BS 9251:2014, in relation to the duration of water supplies where a longer duration is considered to be appropriate. It also indicates whether watermist systems may be used for the permitted variation.

Table 2 AWFSS and categories for use with permitted variations

Provision of AWFSS	Subclause in BS 9991:2015	Sprinkler system conforming to BS 9251:2014	Sprinkler system conforming to BS EN 12845	Watermist system conforming to DD 8458-1 ^{A)}
Multi-basement buildings	5.2.1.2d)	Category 1 using the density in Table 2, Footnote A)a)	OH1 hazard classification or higher	Applicable
Houses with one floor more than 4.5 m above ground floor level	6.3c)2)	Category 1 using the density in Table 2, Footnote A)a)	OH1 hazard classification or higher	Applicable
Houses with more than one floor above 4.5 m	6.4b)	Category 1 using the density in Table 2, Footnote A)a)	OH1 hazard classification or higher	Applicable
Loft conversions	6.5,2)	Category 1 using the density in Table 2, Footnote A)a)	OH1 hazard classification or higher	Applicable
Extended travel distances in common corridors	7.4/11.2	Category 2 using the density in Table 2, Footnote B)	OH1 hazard classification or higher	Not applicable
Internal planning of flats and maisonettes	9.1d)	Category 1 using the density in Table 2, Footnote A)a)	OH1 hazard classification or higher	Applicable
Provision of inner rooms in flats not more than 4.5 m in height	9.3b)	Category 1 using the density in Table 2, Footnote A)a)	OH1 hazard classification or higher	Applicable
Extended travel distances within an open-plan flat	9.4.2a)	Category 1 using the density in Table 2, Footnote A)a)	OH1 hazard classification or higher	Applicable
Extended travel distances within a flat entered from a floor below the flat	9.4.3a)	Category 1 using the density in Table 2, Footnote A)a)	OH1 hazard classification or higher	Applicable
Maisonettes having a floor level higher than 4.5 m above access level	9.5.2d)	Category 1 using the density in Table 2, Footnote A)a)	OH1 hazard classification or higher	Applicable
Open-plan flats	9.7	Category 1 using the density in Table 2, Footnote A)a)	OH1 hazard classification or higher	Applicable
Increased travel distance within cluster flats	9.8.1	Category 2 using the density in Table 2, Footnote B)	OH1 hazard classification or higher	Not applicable

Table 2 AWFSS and categories for use with permitted variations

Provision of AWFSS	Subclause in BS 9991:2015	Sprinkler system conforming to BS 9251:2014	Sprinkler system conforming to BS EN 12845	Watermist system conforming to DD 8458-1 ^{A)}
Flats where occupants are not capable of independent evacuation	11.1	Category 1 using the density in Table 2, Footnote A)a)	OH1 hazard classification or higher	Applicable
Common areas (excluding common corridors and staircases) where occupants are not capable of independent evacuation	11.1	Category 2 using the density in Table 2, Footnote B)	OH1 hazard classification or higher	Applicable
Buildings over 30 m	11.1/16.2.2	Category 2 (it is not necessary to increase the density in accordance with Table 2, Footnote B)	OH1 hazard classification or higher	Not applicable
Reduction in periods of fire resistance	Table 4	Category 2 using the density in Table 2, Footnote B) with a water duration of a minimum of 60 min	OH1 hazard classification or higher	Not applicable
External fire spread and doubling unprotected areas	18.4e)	Category 2 using the density in Table 2, Footnote B)	OH1 hazard classification or higher	Not applicable
Where buildings are not provided with fire mains	50.1.2	Category 2 using the density in Table 2, Footnote B)	OH1 hazard classification or higher	Not applicable
Increased hose distances from a fire-fighting shaft	50.2.2	Category 2 using the density in Table 2, Footnote B)	OH1 hazard classification or higher	Not applicable
Flats in atria buildings	Figure C.1	Category 2 using the density in Table 2, Footnote B)	OH1 hazard classification or higher	Not applicable
Protecting the base of an atrium or ancillary accommodation	Figure C.1	Not applicable	OH1 hazard classification or higher	Not applicable

Table 2 AWFSS and categories for use with permitted variations

Provision of AWFSS	Subclause in BS 9991:2015	Sprinkler system conforming to BS 9251:2014	Sprinkler system conforming to BS EN 12845	Watermist system conforming to DD 8458-1 ^{A)}
Balcony escape where smoke-retarding construction is provided to an atrium	C.2.1, Option 3	Category 2 using the density in Table 2, Footnote B)	OH1 hazard classification or higher	Not applicable
Balcony escape where no construction is provided between a balcony and an atrium	C.2.1	Category 2 using the density in Table 2, Footnote B)	OH1 hazard classification or higher	Not applicable

^{A)} At the time of publication of BS 9991, DD 8458-1 is undergoing conversion to a full British Standard as BS 8458.

12 Manual fire-fighting equipment

A fire risk assessment should be undertaken to determine the need for manual fire-fighting equipment in common access corridors and in other areas of the premises.

NOTE 1 In common access corridors, manual fire-fighting equipment is not normally required.

Where provided, portable fire extinguishers should conform to BS EN 3 (all parts) and should be selected, installed and maintained in accordance with BS 5306-3 and BS 5306-8.

As the residents of specialized housing might not be expected to use manual fire-fighting equipment, its provision should be restricted to higher fire risk areas such as communal lounges, communal kitchens, and wardens' accommodation.

NOTE 2 Where manual fire-fighting equipment is provided, it is important that there are persons on the premises who are familiar with the use of the equipment.

13 Special risk protection

Automatic fire suppression systems and equipment on premises should be selected in accordance with BS 5306-0.

NOTE 1 Special risks, such as oil storage tank chambers and oil-fired boiler rooms, might require the installation of an automatic fire suppression system associated with the risk alone.

Where a building is otherwise provided with sprinkler protection, any enclosed car park accessed from within the building should also be provided with sprinklers in accordance with BS EN 12845.

Car stackers should be protected with an appropriately designed sprinkler system, to ensure that water reaches every vehicle and to contain fire spread.

NOTE 2 Car stackers pose an increased fire risk within car parks. This can be as a result of:

- *an increased risk of vertical fire spread up the stack and the potential for a very large fire involving numerous vehicles;*

- *rapid evolution of elevated temperatures and combustion products within the car park;*
- *potential structural damage to the fabric of the building;*
- *potential for early structural collapse of the unprotected framework of the stacker with associated hazards for fire-fighters.*

14 Smoke control

14.1 Smoke control for means of escape

COMMENTARY ON 14.1

Whilst the primary aim of smoke control in residential buildings is to protect the staircase enclosure, it can also provide some protection to the adjacent protected corridor or lobby.

In extended corridors, the primary objective of the smoke control system is to protect both the common corridor and the staircase enclosure for means of escape.

There are three main methods of smoke control: natural smoke ventilation, mechanical smoke ventilation and pressurization. Further information on these is given in Annex A and BS EN 12101-6.

See Diagram C.7 in the Building Regulations 2010, Approved Document B [14] regarding the free area of smoke ventilators.

14.1.1 General

In residential buildings designed with a stay put strategy (see **A.1**), additional protection to the staircase should be provided in the form of a smoke control system.

The smoke control system within residential buildings should be located such that it is maintainable from the common parts of the building.

14.1.2 Small buildings with a single stair

Small buildings having a single stair in accordance with **7.5** should be designed and constructed in accordance with the following recommendations.

- a) Small buildings having a single stair and a common lobby approach to the dwellings [see Figure 8a)] should have:
 - 1) an openable vent having a minimum free area of 1 m², that is inserted at the highest level practicable at each floor level within the staircase; or
 - 2) an openable vent having a minimum free area of 1 m² at the top of the staircase that can be remotely operated at fire and rescue service access level.
- b) Small buildings having a single stair and no common lobby [see Figure 8b)] should have an AOV with a minimum free area of 1 m² at the top of the staircase that operates on detection of smoke anywhere within the staircase enclosure. The maximum travel distance in the communal areas should be limited to 4.5 m, otherwise the means of escape strategy should be designed as a building in excess of 11 m in height (see **14.1.3**).

The smoke control strategy given in item a) should not be used with an open-plan flat layout design. Vents that can be opened remotely should be in accordance with **14.2.2.3**.

AOVs should be in accordance with **14.2.2.4**.

14.1.3 Buildings with a floor level over 11 m above ground level and served by a single stair

In a building which has accommodation on two or more sides of the common stair, the various wings of the building should be isolated by fire doors in accordance with 24.1 in order to prevent corridors from becoming contaminated by smoke [see Figure 6a)].

For protected corridor or protected lobby access dwellings [see Figure 6a) and Figure 6b)], the smoke control system should have one of the following:

- a) AOVs to the exterior of the building with a minimum free area of 1.5 m², fitted in the common corridor or lobby directly adjacent to the stair at as high a level as is practicable, and an AOV that is sited at as high a level as is practicable on the top storey of the stairway, having a minimum free area of 1 m²; or
- b) a smoke shaft in accordance with 14.2.3 that is fitted in the protected lobby or corridor, and an AOV that is sited at as high a level as is practicable on the top storey of the stairway, having a minimum free area of 1 m²; or
- c) a mechanical smoke ventilation system in accordance with 14.2.4 that is fitted in the protected lobby or protected corridor, directly adjacent to the staircase enclosure, and an AOV that is sited at as high a level as is practicable on the top storey of the stairway, having a minimum free area of 1 m²; or
- d) a pressure differential system.

NOTE Further information is given in Annex A.

The AOVs should operate in accordance with 14.2.2.4.

Where travel distances are in excess of those recommended in Figure 6, a mechanical smoke ventilation system may be used (see A.3).

14.1.4 Multiple-stair buildings

The smoke control provisions in buildings having multiple stairs should be the same as those for single-stair buildings above 11 m (see 14.1.3); however, any vents to the exterior of the building may also be manually operated. Where manually operated vents are used, the smoke control system should be designed to open the vent at the head of the stair either before, or at the same time as the vent on the fire floor.

Manually openable vents should be in accordance with 14.2.2.2.

Where the vents discharge into a smoke shaft, the vents on the fire floor, at the top of the smoke shaft and on the stairway should all be configured to open simultaneously upon automatic activation of the system in the common corridor or lobby. The vents from the corridors or lobbies on all other storeys should be configured to remain closed.

14.1.5 Smoke control in balcony approach or deck approach buildings

Buildings with a balcony approach or a deck approach should be provided with an openable vent with a free area of 1 m² at the top of any enclosed staircase, which can be remotely operated at fire and rescue service access level (see Figure 5).

14.1.6 Smoke control for protected lobbies and corridors

Any common stair which does not form part of the only escape route from a flat may also serve ancillary accommodation if it is separated from the ancillary accommodation by a protected lobby or protected corridor.

If the stair serves an enclosed car park or an area with a higher fire risk, the lobby or corridor should be provided with an area of permanent ventilation of not less than 0.4 m² or be protected from the ingress of smoke by a mechanical smoke ventilation system.

NOTE Smoke control in corridors where every dwelling is provided with an alternative escape route to a common stair do not have to use their normal means of access as their only escape route. On this basis, it is only necessary for their normal access route to be provided with ventilation to clear smoke that can be operated manually by the fire and rescue service.

14.2 Heat and smoke control for fire-fighting

NOTE The build-up of smoke and heat emanating from a fire can seriously inhibit the ability of the fire and rescue service to carry out rescue and fire-fighting operations within a building.

14.2.1 Smoke control for fire-fighting shafts

14.2.1.1 General

All fire-fighting shafts should be provided with a smoke ventilation system.

NOTE 1 Only natural smoke shafts or mechanical pressure differential systems are suitable for buildings over 30 m in height.

NOTE 2 Natural ventilation is not suitable for fire-fighting shafts serving basements more than 10 m below ground level.

NOTE 3 Further information on the design of smoke ventilation systems is given in Annex A.

14.2.1.2 Venting of fire-fighting shafts by natural means

14.2.1.2.1 General

Fire-fighting shafts above ground level that only serve flats should be provided with a natural smoke control system.

Fire-fighting lobbies at basement level should be provided with:

- a) a manually openable 1 m² free area vent at high level, direct to open air or to a smoke shaft serving only that level. Permanently open vents should not be installed; or
- b) an extension of an above ground smoke shaft serving each lobby level.

14.2.1.2.2 Basement smoke shafts

Smoke shafts serving basements should discharge smoke directly into open air at ground level. The smoke shafts should not discharge smoke by the building exits or by fire and rescue access points.

Basement smoke shafts serving more than one floor should be provided with AOVs that operate in accordance with **14.2.2.4**.

Basement smoke shafts should be covered with either:

- a) a metal grille designed to prevent the shaft becoming blocked by rubbish; or
- b) a breakable material, which is easily accessible from the fire and rescue service access level.

14.2.1.3 Venting of smoke and heat from basements

14.2.1.3.1 General

A system of smoke and heat ventilation should be provided from every basement, except for any basement storey that has:

- a) a floor area of not more than 200 m²; or
- b) a floor level not more than 3 m below the adjacent ground level.

NOTE 1 Basement compartments having external doors or windows do not need smoke outlets, as long as the floor area recommendations are met. It is common for basements to be open to the air on one or more elevations.

Systems may be either natural, using one or more smoke outlets conforming to **14.2.1.3.2**, or mechanical, conforming to **14.2.1.3.3**.

*NOTE 2 For recommendations regarding smoke and heat ventilation systems from basement car parks, see **14.2.1.4**.*

14.2.1.3.2 Natural smoke and heat ventilation

Smoke outlets provide a route for smoke to escape to the open air from the basement level(s). If a basement is compartmented, each compartment should have direct access to vents without having to open doors, for example, into another compartment.

NOTE 1 Smoke outlets are often referred to as smoke vents.

Smoke outlets should be:

- a) not less than 2.5% of the floor area of each storey;
- b) sited at the highest level practicable, either in the ceiling or in the wall of the space they serve;
- c) evenly distributed around the perimeter of the building, to discharge into the open air outside the building;
- d) located such that they would not prevent the use of escape routes from the building.

If an outlet terminates at a point that is not readily accessible, it should be unobstructed, and should be covered only with a non-combustible grille or louvre.

If an outlet terminates in a readily accessible position, it may be covered by a panel, stallboard or pavement light that can be broken out or opened. The position of such covered outlets should be suitably marked.

NOTE 2 The fire and rescue service can be consulted for further information regarding suitable marking of smoke outlets.

Separate outlets should be provided from places of special fire hazard (see Clause 13).

14.2.1.3.3 Mechanical smoke and heat ventilation

A system of mechanical smoke and heat ventilation may be provided within the basement as an alternative to natural venting, to remove smoke and heat from basements, provided that the basement storey(s) are fitted with a sprinkler system.

The sprinkler system in the basement should be in accordance with BS EN 12845. Where a powered extract system is used, it should:

- a) provide ten air changes per hour;
- b) be capable of handling gas temperatures of 300 °C for a continuous period of not less than 60 min;
- c) operate automatically either on activation of the sprinkler system or by a fire detection and fire alarm system in accordance with BS 5839-1:2013 at a minimum standard of L3.

NOTE Further guidance on powered smoke and heat exhaust ventilators is given in BS EN 12101-3.

In addition:

- 1) replacement air should be provided and the vent should open automatically, using the same activation method as that selected in **14.2.1.3.3c**);
- 2) the system should have an independent power supply that operates in the event of failure of the main power supply;
- 3) the ductwork and fixings should be constructed of materials capable of withstanding temperatures of at least 600 °C for a period no less than 60 min, or the equivalent to the fire-resistance rating of any compartment boundary through which it passes, whichever is the greater;
- 4) all wiring associated with the fans should be in accordance with BS 8519:2010.

14.2.1.4 Venting of smoke and heat from covered car parks

A smoke and heat ventilation system should be provided from every car park storey, designed in accordance with BS 7346-7 and having the objective of clearing smoke during a fire and/or after a fire has been suppressed.

NOTE Further information and guidance regarding car parks (open-sided and non-open-sided car parks, mechanical and natural ventilation) is given in the Building Regulations 2010, Approved Document B [14].

14.2.2 Vents

14.2.2.1 General

The top of all lobby or corridor vents should be located as closely to the ceiling of the lobby or corridor as is practicable, and should be at least as high as the top of the door connecting the lobby or corridor to the stairwell.

The top of all staircase vents should be located as closely to the ceiling of the floor level served as is practicable.

NOTE Further guidance on equipment specification and relevant test standards can be found in the Smoke Control Association publication Guidance on smoke control to common escape routes in apartment buildings (flats and maisonettes) [18].

14.2.2.2 Manually openable vents

All manually openable vents provided for smoke control, whether in the stairs, in a protected lobby or in a protected corridor should:

- a) achieve the relevant free area (see Commentary on **14.1**);
- b) be outward opening;
- c) not be top-hung;
- d) open to a minimum of 30°;
- e) be clearly identifiable and accessible;

- f) be fitted with:
- 1) simple lever handles; or
 - 2) rotary drives to simple rack or gear operated devices; or
 - 3) locks that can be readily and easily operated by the fire and rescue service.

NOTE It might be advisable to seek advice from the fire and rescue service.

Openings should be guarded to a height of not less than 1.1 m from floor level.

14.2.2.3 Remotely openable vents

Openable vents in accordance with 14.1.2a)2) situated above a stair should be provided with a remote control located adjacent to the fire and rescue service access doorway. The function and means of operation of the remote control should be clearly marked. The remote control should be capable of opening and closing the vent.

All connections between the remote control and actuator mechanism should be within an environment that provides protection from expected fire conditions. Where any part of the remote control mechanism is powered by electricity, a secondary supply should be provided.

14.2.2.4 Automatic opening vents (AOVs)

AOVs opening to outside air should conform to BS EN 12101-2.

AOVs in small single-stair buildings should be configured to open when smoke is detected anywhere in the staircase enclosure.

Vents designed to open automatically from the top storey of the stairs in buildings other than small single-stair buildings should be configured to operate upon smoke detection within any of the protected corridors or protected lobbies directly adjacent to the staircase enclosure.

Only the AOV leading from the protected corridor or protected lobby where the smoke has been detected should be configured to open. This should open either to external air or into a smoke shaft; all other protected lobby vents should be configured to remain closed. Fire and rescue service override controls should not permit multiple lobby vents to be open simultaneously.

NOTE 1 This applies whether the vent opens to outside air or into a natural or mechanical shaft.

Unless a simultaneous evacuation arrangement is deemed appropriate, there should be no sounders attached to the smoke detectors within common parts.

NOTE 2 The purpose of smoke detectors is to operate the smoke control system, not to raise an alarm.

All connections between the smoke detection, vent control panels and actuator mechanisms should be within an environment that provides protection from expected fire conditions.

Where any part of the control mechanism is powered by electricity, a secondary supply should be provided.

14.2.3 Smoke shafts

14.2.3.1 General

Any smoke shaft that penetrates a fire compartment should, as a minimum, maintain the same level of fire compartmentation as that which has been breached.

14.2.3.2 Natural smoke shafts situated above ground level

Smoke shafts serving storeys above ground level should meet the following recommendations.

- a) The smoke shaft should be fully open to the external air at the top and closed at the base.
- b) The opening at the top of the smoke shaft should be located at least 0.5 m above any surrounding structures that fall within a 2 m radius on a horizontal plane so that it is not subject to adverse wind effects (i.e. it should always have negative wind pressure coefficients).
- c) The shaft should extend a minimum length of 2.5 m above the ceiling of the highest storey which is served by the shaft.
- d) The cross-sectional area (free area) of the smoke shaft should be at least 1.5 m², with a minimum dimension of 0.85 m in any direction.
- e) The lobby or corridor vent, the opening at the head of the shaft and all internal locations (such as safety grilles) within the shaft should have a free area of at least 1.0 m².
- f) The top of the lobby or corridor vent should be located as close to the ceiling of the lobby or corridor as is practicable, and should be at least as high as the top of the door connecting the lobby or corridor to the stairwell.
- g) The lobby or corridor vents, in the closed position, should have a minimum fire and smoke resistance performance of 30 min and integrity (leakage) no greater than 360 m³/h/m² when tested in accordance with BS EN 1366-2.
- h) The smoke shaft should be constructed either of non-combustible materials conforming to BS 476-4 or of any material which, when tested in accordance with BS 476-11, does not flame or cause any rise in the temperature on either the centre of the specimen or the furnace thermocouples. The smoke shaft should run vertically from top to bottom with no more than 4 m of the shaft at an inclined angle (max 30°).
- i) No services other than those relating to the smoke shaft should be contained within the smoke shaft.
- j) The smoke shaft should be located at the remote end of the corridor away from the staircase.

14.2.4 Mechanical smoke ventilation systems

Where a mechanical smoke ventilation system uses a shaft, it should be in accordance with 14.2.3.2a), f), g), i) and j).

A mechanical smoke ventilation system should demonstrate conditions in the lobby or corridor and stairs that are equivalent to or better than the natural ventilation system that it replaces.

NOTE 1 This is usually shown by a comparative computational fluid dynamics analysis.

The design of the mechanical smoke ventilation system should limit pressure differentials so that door opening forces do not exceed 100 N at the door handle when the system is in operation.

A secondary power supply should be provided to the fans and all actuators and controls.

Fan sets should usually be provided with a standby fan that operates automatically upon failure of the duty fan.

NOTE 2 Further information regarding mechanical smoke ventilation systems is given in Annex A.

14.3 Design, installation, commissioning and maintenance

Design, installation, commissioning and maintenance of smoke control systems should be carried out in accordance with BS 7346-8.

15 Power supplies, cabling and installation

All power supplies, electrical wiring and control equipment should be protected against fire for an appropriate period of time where the effects of fire are likely to result in the failure or incorrect operation of the life safety system.

Power and control cables should be installed in accordance with BS 8519:2010.

Where dual power supplies are recommended by the relevant British Standard or industry guide to any life safety system, the primary power source should generally be taken from the public electricity supply, with secondary power being supplied from an alternative utility supply from another substation, a generator, an uninterruptible power supply (UPS) or batteries.

The output of each power supply should be sufficient to satisfy the maximum demands of the system.

Where practicable, power supplies should be provided via two separate intakes into the building from the same external substation or via a single intake and a standby generator. Where neither of these options is technically viable, e.g. a risk assessment has been undertaken which concludes that a life safety generator would not be suitable, a single intake from the external substation may be provided as the only alternative option remaining, provided that the following recommendations are met.

- a) The life safety system should be connected to an independent distribution board used exclusively for that system.
- b) The life safety distribution board should be clearly marked at the point of isolation with a warning explaining that isolation would switch off the life safety system.
- c) The life safety distribution board should be located in a separate fire-resisting enclosure (with a minimum of 60 min fire-resisting construction) to the primary main electrical distribution board and should not be accessible directly from the communal areas of the building or from a part of the building where dual supply is required (such as a shaft serving an evacuation lift).
- d) The enclosure surrounding the primary main electrical distribution board should be provided with a minimum of 60 min fire-resisting construction.
- e) The substation or transformer room should be either located outside the building, or separated by 120 min fire-resisting construction and directly accessible from the outside.

The diverse (primary and secondary) power cables should only come together in the fire compartment housing the control panel by means of an automatic change-over switch, unless the cable route is via a fire compartment which does not open onto areas requiring protection via the relevant life safety system.

NOTE 1 Where the secondary power source is not taken from a generator, alternative utility supply or primary main electrical distribution board, and is contained within the fire compartment housing the control panel (e.g. a control panel containing battery back-up providing secondary power and control for an extra low voltage system), then secondary power cables are not required.

NOTE 2 Particular attention is drawn to the requirement in BS 7671 for suitable support of cabling to avoid obstruction of escape routes and fire-fighting access due to the failure of fixings.

If the primary power source fails, then the power supply should be automatically switched over to a secondary power source. Failure of or damage to one of the power sources should not cause the failure of the other power source or the failure of the supply of power to the system.

The electrical distribution system should conform to BS 7671, the relevant parts of BS EN 60947, and BS 7346-8.

Section 4: Design for construction

16 Fire resistance

COMMENTARY ON CLAUSE 16

For the purposes of complying with the recommendations for means of escape in case of fire, a 30 min period of fire resistance is generally considered adequate. Increased periods of fire resistance might, however, be necessary: firstly to assist in protecting individuals who remain in adjacent dwellings owing to a stay put policy (see A.1), and secondly to provide adequate safety for fire-fighting.

Elements of structure (columns, floors, walls, etc.) might not inherently possess sufficient fire resistance. A variety of methods of additional fire protection is available in the form of protective coverings, casings or membranes, but designers need to take into account the risk of damage. As an alternative, a sprinkler system may be fitted throughout the building to limit temperatures and protect the structure (see Clause 11).

For the fire resistance of compartmentation, see Clause 17.

16.1 General

Fire resistance should be not less than 30 min when tested in accordance with the relevant part of BS 476 or equivalent European standard for:

- a) load-bearing walls, for load-bearing capacity, integrity and insulation from either side;
- b) non-load-bearing walls and partitions, for integrity and insulation from either side;
- c) fire doors for integrity from either side, with the exception of doors to lift wells where performance is in respect of exposure of the landing side only and which are tested in accordance with BS EN 81-58;
- d) floors, for load-bearing capacity, integrity and insulation with respect to exposure of the underside only.

16.2 Minimum levels of fire resistance for elements of structure

16.2.1 General

When tested in accordance with the relevant part of BS 476, BS EN 1363, BS EN 1364, BS EN 1365 or BS EN 1366, the elements of structure identified in Table 3 should have a fire resistance not less than the minimum values recommended in Table 4 or Table 5. To use these tables, the fire resistance (load-bearing capacity, integrity and insulation) should first be determined from Table 3; then the fire resistance periods should be determined either from Table 3 if a specific recommendation is given, or from Table 4 or Table 5, depending on whether or not ventilation conditions are to be taken into account (see Footnote A to Table 5).

Table 4 gives recommendations for fire resistance of elements of structure and other parts of a building based upon the fuel load density and assuming an unventilated fire. Table 5 gives recommendations for fire resistance of elements of structure based upon ventilation conditions. Table 5 should be used only if the ventilation conditions can be met; if these conditions cannot be met then Table 4 should be used.

COMMENTARY ON TABLE 4 AND TABLE 5

Fire loads are built into Table 4 and Table 5, which reflect the normal fire loadings within a residential building.

The provision of an automatic sprinkler system significantly reduces the severity of a fire. The fire resistance of compartment walls and floors can be changed if sprinklers are provided. This is reflected in Table 5.

Traditionally, standards of fire resistance have been based upon the fire load or the fuel load density. However, there are other factors which may be taken into account.

The level of heating that an element experiences is influenced primarily by the fuel load density in the compartment, the insulation properties or thermal inertia, the geometry and ventilation conditions of the fire compartment. These variables, which determine the level of heating in a real fire, can be linked to the standard fire resistance test conditions by the concept of time equivalency (t-equivalency).

The t-equivalent period of fire resistance is a means of calculating a time for which an element in a compartment subject to a real fire would undergo a heating equivalent to the same time period in a standard furnace test. This approach models the heating effects of a real fire by taking into account the actual fuel load density, the thermal inertia of the lining materials, the compartment geometry and ventilation conditions within the compartment.

In order to determine an appropriate fire resistance period for elements of structure, the t-equivalent values can be used as a basis. The values obtained in this way are then factored to take into account the three purposes of structural fire resistance, namely:

- a) to minimize the risk to occupants, some of whom might have to remain in the building for some length of time due to the stay put strategy (see A.1);*
- b) to reduce the risk to fire-fighters who might be engaged in search or rescue operations; and*
- c) to reduce the danger to people in the vicinity of the building, who might be hurt by falling debris or as a result of the impact of the collapsing structure on other buildings.*

Background to the derivation of Table 4

Table 4 has been derived by assessing the risk assessment, fire growth rate and occupants of the building. It largely follows the guidance given in the Building Regulations 2010, Approved Document B [14].

Background to the derivation of Table 5

Table 5 has been developed using fundamental fire safety engineering principles which use a combination of deterministic analysis combined with a risk and consequence evaluation to reflect the severity of a real fire and the threat to life safety in residential buildings.

The deterministic analysis employed a time equivalent approach based upon the validated parametric expressions given in BS EN 1991-1-2, for post-flashover fires. This considers basic factors such as the fire load density, ventilation, the thermal properties of the enclosure, compartment size and geometry. In order to cover a wide range of variables for the parametric fire, a Monte Carlo analysis was carried out involving many thousands of fires to ensure the extreme combination of variables were captured. The analysis assumes a total burn-out of the fire.

The effectiveness of sprinklers in reducing the fire severity was considered in the form of applying a multiplication factor based upon risk, to the fire load density.

From the Monte Carlo analysis, the cumulative distributions of time equivalent were subsequently analysed based upon the fundamental premise that risk = frequency × probability × consequence of failure. The frequency was linked with the height of the building following the principles of the Building Regulations 2000 [19], and consequence of failure was linked to both the building height and risk profile of the occupancy taking account of the familiarity and mobility of the occupants within the building and the sleeping risk. The probability of failure is directly related to the cumulative distribution curves that resulted from the Monte Carlo analysis.

NOTE 1 The fire resistance periods given in Table 4 are based on the minimum levels required for life safety given in the Building Regulations 2010, Approved Document B [14] and are not necessarily adequate for property protection and business continuity.

NOTE 2 Table 4 gives recommendations for fire resistance of elements of structure for basement storeys. These elements are not covered in Table 5.

NOTE 3 Minimum levels of fire resistance for fire doors are given in 24.1.

16.2.2 Buildings over 30 m high

Buildings having an occupied storey over 30 m above access level should be sprinkler-protected throughout in accordance with BS 9251:2014 or BS EN 12845 (see 11.2, Table 2).

16.2.3 Single-storey buildings

In single-storey buildings where there are compartment walls, or where an external wall is close enough to the relevant boundary to require it, structural fire resistance should be provided.

16.2.4 Roof structure

The structure of a roof, and the structure that supports only a roof, does not generally require fire resistance unless the roof forms part of an escape route or functions as a floor, e.g. as a car park, or is part of a portal frame structure where the roof and the supporting stanchions form a single structural element.

16.2.5 Suspended ceilings

A suspended ceiling can contribute to the overall fire resistance of a floor/ceiling assembly. If a suspended ceiling is used it should be in accordance with Table 6.

Table 3 Minimum fire resistance performance

Part of building	Minimum provisions when tested to the relevant parts of BS 476, in minutes ^{A)}		Minimum provisions when tested to the relevant European standard, in minutes ^{B)}		Method of exposure
	Load-bearing capacity ^{C)}	Integrity	Insulation	Load-bearing capacity ^{C)}	
Structural frame, beam or column	See Table 4 or Table 5	Not applicable	Not applicable	See Table 4 or Table 5	Exposed faces
Load-bearing wall element	See Table 4 or Table 5	Not applicable	Not applicable	See Table 4 or Table 5	Each side separately
Floor^{D)}					
Between a shop and a flat above	60 or see Table 4 or Table 5 ^{F)}	60 or see Table 4 or Table 5 ^{F)}	60 or see Table 4 or Table 5 ^{F)}	60 or see Table 4 or Table 5 ^{F)}	From underside ^{E)}
Any other floor, including compartment floors	See Table 4 or Table 5	See Table 4 or Table 5	See Table 4 or Table 5	See Table 4 or Table 5	From underside ^{E)}
Roof					
Any part forming an escape route	30	30	30	30	From underside ^{E)}
Any roof that performs the function of a floor	See Table 4 or Table 5	See Table 4 or Table 5	See Table 4 or Table 5	See Table 4 or Table 5	From underside ^{E)}
External wall					
Any part less than 1 m away from any point on the relevant boundary	See Table 4 or Table 5	See Table 4 or Table 5	See Table 4 or Table 5	See Table 4 or Table 5	Each side separately
Any part 1 m or more from the relevant boundary ^{G)}	See Table 4 or Table 5	See Table 4 or Table 5	See Table 4 or Table 5	See Table 4 or Table 5	From inside the building
Any part adjacent to an external escape route	30	30	No provision ^{H), I)}	30	From inside the building
Compartment wall					
Walls separating occupancies (see Clause 17)	60 or see Table 4 or Table 5 ^{J)}	60 or see Table 4 or Table 5 ^{J)}	60 or see Table 4 or Table 5 ^{J)}	60 or see Table 4 or Table 5 ^{J)}	Each side separately
Any other compartment walls	See Table 4 or Table 5	See Table 4 or Table 5	See Table 4 or Table 5	See Table 4 or Table 5	Each side separately

Table 3 Minimum fire resistance performance

Part of building	Minimum provisions when tested to the relevant parts of BS 476, in minutes ^{A)}		Minimum provisions when tested to the relevant European standard, in minutes ^{B)}		Method of exposure
	Load-bearing capacity ^{C)}	Integrity	Insulation	Load-bearing capacity ^{C)}	
Protected shaft, excluding any fire-fighting shafts					
Glazed screen separating protected shaft from lobby or corridor	Not applicable	30	No provision ^{K), L)}	Not applicable	Each side separately
Any other part between the shaft and a protected corridor/lobby	30	30	30	30	Each side separately
Any other part not described above	See Table 4 or Table 5	See Table 4 or Table 5	See Table 4 or Table 5	See Table 4 or Table 5	Each side separately
Fire-fighting shaft					
Construction separating fire-fighting shaft from rest of building	120	120	120	120	From side remote from shaft
Construction separating fire-fighting stair, fire-fighting lift shaft and fire-fighting lobby	60	60	60	60	From shaft side
	60	60	60	60	Each side separately
Enclosure					
To a protected lobby or a protected corridor (not forming part of a compartment wall or a protected shaft)	30	30	30 ^{K)}	30	Each side separately
In a flat, to a protected entrance hall or a protected landing	30	30	30 ^{K)}	30	Each side separately
Subdivision of a corridor	30	30	30 ^{K)}	30	Each side separately
Fire-resisting construction					
Enclosing communal areas	30	30	30 ^{K)}	30	Each side separately
Enclosing places of special fire hazard	30	30	30	30	Each side separately

Table 3 Minimum fire resistance performance

Part of building	Minimum provisions when tested to the relevant parts of BS 476, in minutes ^{A)}			Minimum provisions when tested to the relevant European standard, in minutes ^{B)}			Method of exposure
	Load-bearing capacity ^{C)}	Integrity	Insulation	Load-bearing capacity ^{C)}	Integrity	Insulation	
Cavity barrier	Not applicable	30	15	Not applicable	30	15	Each side separately
Duct^{M)}	Not applicable	30	No provision	Not applicable	30	No provision	From outside
Casing around a drainage system^{N)}	Not applicable	30	No provision	Not applicable	30	No provision	From outside
Flue walls^{O)}	Not applicable	Half the period given in Table 4 or Table 5 for compartment wall/floor	Half the period given in Table 4 or Table 5 for compartment wall/floor	Not applicable	Half the period given in Table 4 or Table 5 for compartment wall/floor	Half the period given in Table 4 or Table 5 for compartment wall/floor	From outside
Fire door	See Table 12	See Table 12	See Table 12	See Table 12	See Table 12	See Table 12	
Construction enclosing a roadway	120	120	120	120	120	120	From the roadway side

Table 3 Minimum fire resistance performance

Part of building	Minimum provisions when tested to the relevant parts of BS 476, in minutes ^{A)}		Minimum provisions when tested to the relevant European standard, in minutes ^{B)}		Method of exposure
	Load-bearing capacity ^{C)}	Integrity	Load-bearing capacity ^{C)}	Integrity	
A) Part 21 for load-bearing elements, Part 22 for non-load-bearing elements, Part 23 for fire-protecting suspended ceilings, and Part 24 for ventilation ducts.					
B) The national classifications do not automatically equate with the equivalent classifications in the European column, therefore products cannot typically assume a European class unless they have been tested accordingly.					
C) "R" rating applies to load-bearing elements only.					
D) Guidance on increasing the fire resistance of existing timber floors is given in BRE Digest 208 [20].					
E) If a suspended ceiling is used it should be in accordance with 16.2.5 and 20.2.					
F) Whichever is greater.					
G) Clause 18 allows such walls to contain areas which need not be fire-resisting (unprotected areas).					
H) Unless needed to meet the recommendations given in Clause 18.					
I) Except for any limitations on glazed elements given in Clause 22.					
J) Whichever is less.					
K) See 22.1 for permitted extent of non-insulated glazed elements.					
L) See 22.2.					
M) See 19.2v).					
N) See 21.4, Figure 30.					
O) See 21.4, Figure 29.					

Table 4 Fire resistance periods for elements of structure (independent of ventilation conditions)

Condition	Minimum periods of fire resistance, in minutes					
	Depth below access level of basement level			Height of top occupied storey above access level		
	>10 m	≤10 m	≤5 m	≤18 m	≤30 m	>30 m
Sprinklered ^{A)}	90	60	30	60	60	120
Unsprinklered	90	60	30	60	90	Not allowed

^{A)} Sprinkler systems should be in accordance with BS 9251:2014 or BS EN 12845 (see 11.2, Table 2).

Table 5 Fire resistance periods for elements of structure (based on ventilation conditions^{A)})

Condition	Minimum periods of fire resistance, in minutes ^{B)}					
	Height of top occupied storey above access level					
	≤5 m	≤11 m	≤18 m	≤30 m	≤50 m	>50 m
Sprinklered ^{C)}	45	60	75	75	90	105
Unsprinklered	60	90	105	120	Not allowed	Not allowed

^{A)} The ventilation conditions for an individual residential building are as follows:

- minimum potential area as a percentage of the floor area: 10%;
- height of opening as a percentage of the compartment height (i.e. from floor to ceiling): 30% to 90%;
- where the opening height is the weighted mean height (by ventilation area) of the potential openings. If a compartment has openings each with an area of $A_1, A_2, A_3, \dots, A_n$ and heights of $h_1, h_2, h_3, \dots, h_n$, then the total area of the openings $A = A_1 + A_2 + A_3 + \dots + A_n$, and the weighted mean height, h , is given by:

$$h = \frac{A_1 h_1 + A_2 h_2 + A_3 h_3 + \dots + A_n h_n}{A}$$

NOTE In the calculation of the weighted mean height it is also acceptable to selectively consider only the height(s) of the openings that achieve the minimum ventilation area.

If h is the weighted mean height of all the openings and H is the height of the compartment then h/H should be between the values given in the end column.

If these ventilation conditions cannot be met then Table 4 should be used instead.

- ^{B)} Where a product or system is not available to meet this recommendation, it is acceptable to use a product or system having the next highest available classification. The classification periods 75 and 105 do not exist in European classification system BS EN 13501-2.
- ^{C)} Where sprinklers are used to vary the provision of fire safety measures, only those installed in accordance with BS 9251:2014 or BS EN 12845 (see 11.2, Table 2) may be used to adjust the fire resistance periods given in Table 5.

Table 6 Provisions for fire-protecting suspended ceilings

Height of building or separated part m	Type of floor	Provision for fire resistance of floor min	Description of suspended ceiling ^{A)}
<18	Not compartment	≤60	Type W, X, Y or Z
<18	Compartment	<60	Type W, X, Y or Z
<18	Compartment	60	Type X, Y or Z
≥18	Any	≤60	Type Y or Z
No limit	Any	>60	Type Z

Any access panels provided in fire protecting suspended ceilings of type Y or Z should be secured in position by releasing devices or screw fixings, and they should be shown to have been tested in the ceiling assembly in which they are incorporated.

NOTE 1 The national classifications do not automatically equate with the equivalent European classifications, therefore products cannot typically assume a European class unless they have been tested accordingly.

NOTE 2 When a classification includes "s3, d2" this means that there is no limit set for smoke production and/or flaming droplets/particles.

^{A)} Ceiling type and description:

W = Surface of ceiling exposed to the cavity should be Class 0 or Class 1 (national) or Class C-s3, d2 or better (European).

X = Surface of ceiling exposed to the cavity should be Class 0 (national) or Class B-s3, d2 or better (European).

Y = Surface of ceiling exposed to the cavity should be Class 0 (national) or Class B-s3, d2 or better (European).

Ceiling should not contain easily openable access panels.

Z = Ceiling should be of a material of limited combustibility (national) or of Class A2-s3, d2 or better (European) and not contain easily openable access panels. Any insulation above the ceiling should be of a material of limited combustibility (national) or Class A2-s3, d2 or better (European).

17 Compartmentation

The following elements should be constructed with a fire resistance of not less than 60 min:

- a) in houses, any wall separating one dwelling from another dwelling or separating the dwelling from accommodation that does not form part of the dwelling;
- b) in flats and maisonettes situated more than 5 m above ground or access level, any floor (unless it is within a maisonette), and any wall separating a flat or maisonette from another part of the building;
- c) any wall enclosing a refuse storage chamber.

A wall common to two or more buildings should be constructed as a compartment wall.

Compartment walls should be able to accommodate the predicted deflection of the floor. This should be achieved in one of the two following ways:

- 1) a head detail should be provided between the compartment wall and the floor, which is capable of deforming while maintaining its integrity when exposed to a fire; or
- 2) the design of the compartment wall should be such that it maintains its integrity by resisting the additional vertical load from the floor above when forced to sag under fire conditions.

NOTE Further information is given in the Building Regulations 2010, Approved Document B [14], 8.27, Note, and Diagram 29.

18 External fire spread and building separation

COMMENTARY ON CLAUSE 18

The recommendations given in this clause are concerned with the measures available to restrict potential to spread fire from the building of origin to a neighbouring structure. Two basic methods of fire spread between buildings are addressed:

- a) direct impingement of flames from one building on another; and
- b) radiation (possibly supplemented by burning debris).

For buildings within 1 m of the relevant boundary (see **18.3.1**), flame spread is the main mechanism for fire spread. Beyond this distance, the mechanism for fire spread is assumed to be radiation.

Fire spread from building to building by radiation is dependent on:

- 1) the distance between and orientation of the building of origin and the neighbouring structure (radiator to receiver) [this is based on the principles of configuration (or view) factor];
- 2) the extent of the building surface capable of transmitting heat (external construction that has fire resistance is considered to have sufficient insulating properties, such that heat transfer can be ignored); and
- 3) the intensity (emissive power) of the source radiation.

The radiative energy emitted by the building of fire origin is dependent on the size and severity of the fire.

For the purposes of the recommendations given in this clause, it is assumed that:

- i) fire does not spread beyond the compartment of origin;
- ii) the compartment of origin has reached flashover;
- iii) all unprotected areas of one compartment are radiating with equal intensity;
- iv) radiation intensity at each unprotected area is 84 kW/m²;
- v) radiation is halved by the action of an automatic sprinkler system; and
- vi) any glazing, and/or the supporting structure, in the façade of the building of fire origin has failed in terms of integrity, unless the glazing system is classified for fire resistance according to the relevant part of either BS 476 or BS EN 13501 to the same standard as the wall as recommended in Table 4.

No account is taken of the attenuation of the level of radiation.

In terms of external fire spread between buildings, the acceptable risk to life is based on the relevant boundary being half the distance between buildings. Neighbouring buildings are assumed to have similar unprotected areas.

NOTE 1 A roof is not subject to the provisions in this clause unless it is pitched at an angle greater than 70° to the horizontal. Similarly, vertical parts of a pitched roof such as dormer windows (which taken in isolation may be regarded as a wall) would not need to meet these provisions unless the slope of the roof exceeds 70°. It is a matter of judgement whether a continuous run of dormer windows occupying most of a steeply pitched roof is to be treated as a wall rather than a roof.

NOTE 2 The measures recommended in this clause will not necessarily protect a building from a fire in an existing building on an adjoining site. The property loss prevention aspects of the situation need to be assessed in each case.

18.1 General

The boundary separation calculations of unprotected areas should relate to a notional boundary between the building and any other building on the site. In this instance, the distance to the relevant boundary (see **18.3**) should be taken as the actual measured distance between the buildings.

18.2 External fire spread over the external faces of buildings

External walls should be constructed using a material that does not support fire spread and therefore endanger people in or around the building.

Flame spread over or within an external wall construction should be controlled to avoid creating a route for rapid fire spread bypassing compartment floors or walls.

NOTE 1 This is particularly important where a stay put strategy (see A.1) is in place.

External wall surfaces near other buildings should not be readily ignitable, to avoid fire spread between buildings.

External walls should either meet the performance criteria given in BRE Report BR 135 [N1] for cladding systems using full scale test data from BS 8414-1 or BS 8414-2, or meet the following recommendations.

- a) The external surfaces of walls should meet the provisions in Figure 17.
- b) In a building with a storey 18 m or more above ground level, any cladding material, insulation product, filler material (not including gaskets, sealants and similar), etc., used in the external wall construction should be of limited combustibility.

NOTE 2 This restriction does not apply to masonry cavity wall construction in accordance with Figure 25 (see 19.1.1).

- c) Cavity barriers should be provided in accordance with Clause 19.
- d) External balconies that are enclosed should be constructed and separated from other enclosed balconies with compartmentation and fire-resisting construction in accordance with Annex D.

18.3 Boundaries

18.3.1 Relevant boundary

The relevant boundary should be taken as the boundary to which separation distance is measured.

NOTE A notional boundary can be a relevant boundary.

The relevant boundary should usually be taken as the site boundary. Where a wall faces onto a space that is unlikely to be developed, such as a road, canal or river, however, then the boundary may be assumed to be an imaginary line half way across this feature.

A wall should be treated as facing a boundary if it makes an angle of 80° or less (see Figure 18).

18.3.2 Notional boundary

COMMENTARY ON 18.3.2

A notional boundary is an imaginary line assumed to exist between two buildings (see Figure 19).

When the need for a notional boundary is determined, its location should be established according to Figure 19.

Where both buildings are new, one should be designated as existing and the recommendation for notional boundary assessed accordingly.

Figure 17 Provisions for external surfaces of walls

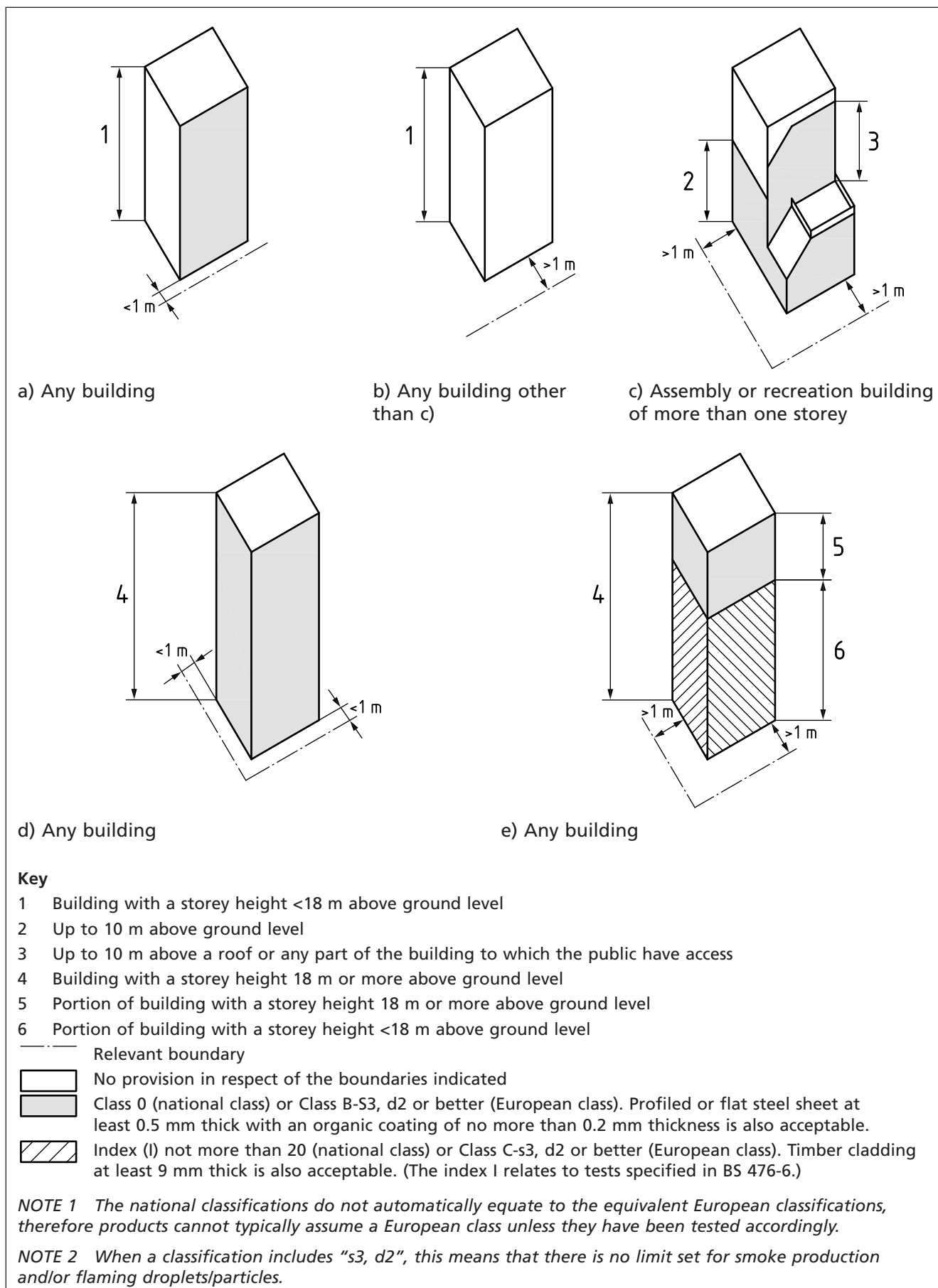
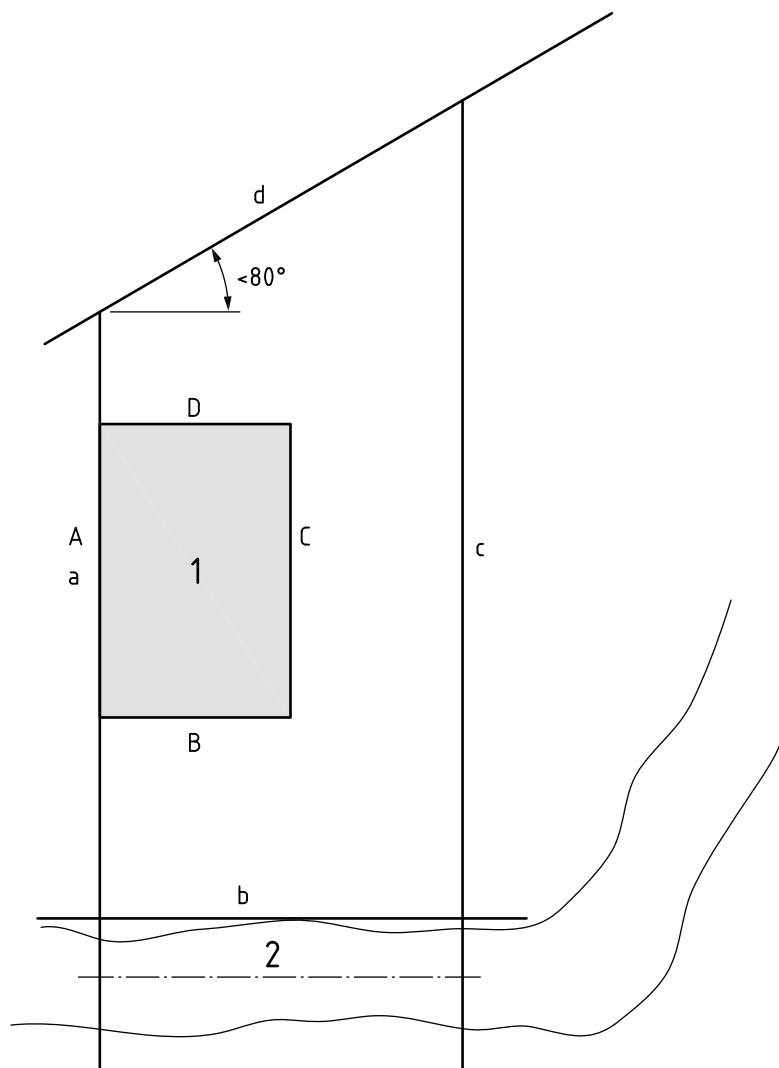

Figure 18 Relevant boundaries



Boundary a is coincident with and therefore relevant to side A. Boundary b is the site boundary.

As the building overlooks a river, canal, road or similar feature, boundary b is taken as relevant to side B.

Boundaries c and d are parallel with, or less than 80° to, sides C and D and are therefore relevant to them.

Key

- 1 Building
- 2 Relevant boundary may be the centre line of a road, railway, canal or river

Figure 19 Notional boundaries

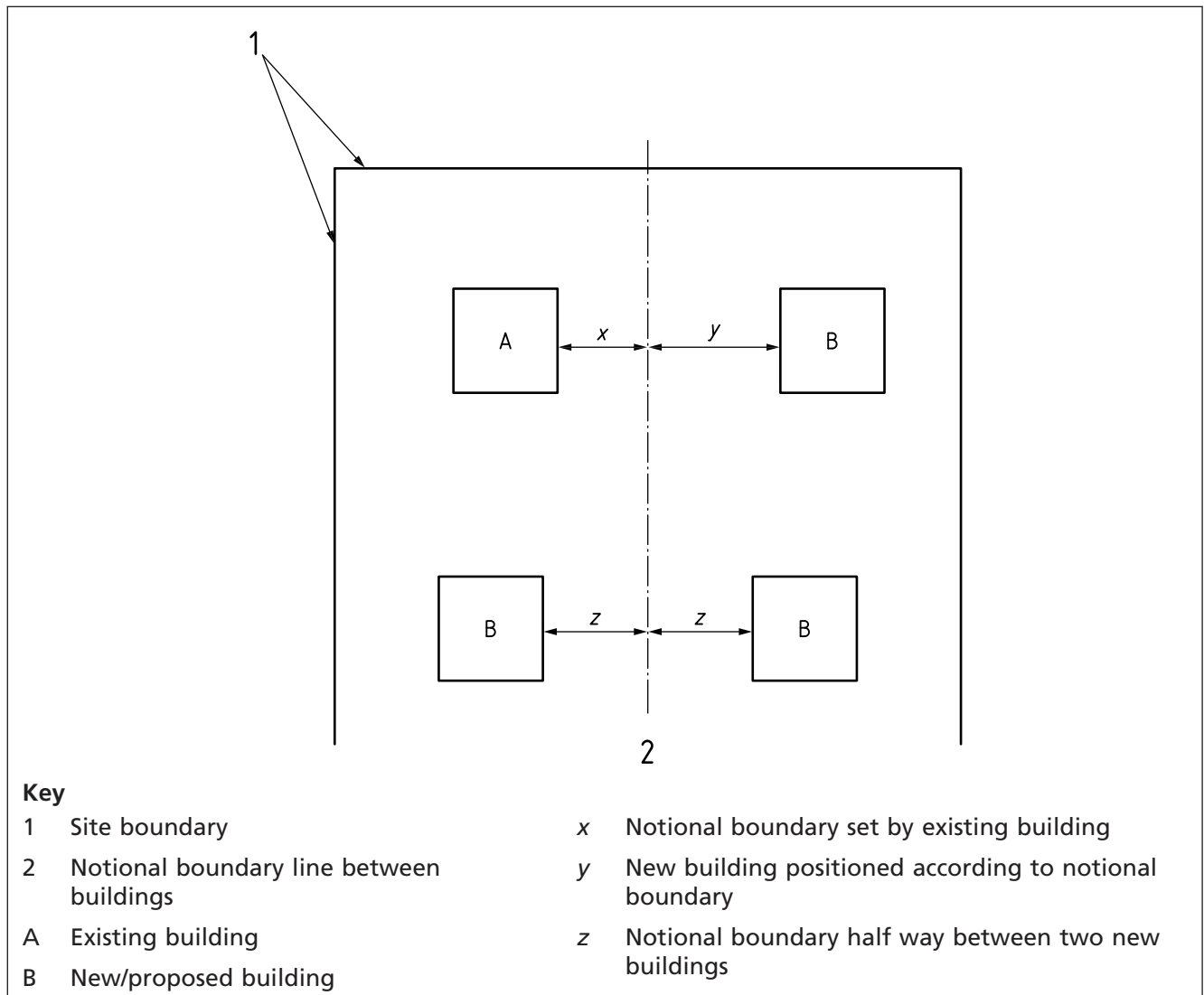

When determining the location of a new building, the position of the notional boundary should be set according to the amount of unprotected area (see 18.4) in the façade of the existing building. A proposed new building should be subject to the restrictions on proximity and extent of unprotected area relevant to this notional boundary (see 18.5.3).

Where both buildings are new, the notional boundary should be assumed to exist half-way between the two buildings and the location of each should be set accordingly.

18.3.3 Property protection between buildings on the same site

The principle of a notional boundary can be applied to any building for property protection purposes. In these circumstances the recommendations in 18.3.2 should be met.

18.4 Unprotected area

The following factors should be taken into account when determining the extent of the unprotected area.

- a) For life safety, any part of an external façade that has a period of fire resistance less than the appropriate level recommended in Table 3 is counted as an unprotected area.
- b) Included in the unprotected area calculation is any section of external wall which has the appropriate standard of fire resistance, but has a combustible material more than 1 mm thick as its external surface. However, this section of wall is counted as having an unprotected area amounting to half the actual area of the combustible surface (see Figure 20).
- c) The amount of unprotected area in the façades of buildings needs to be restricted according to the distance between these façades and the relevant (or notional) boundaries (see 18.5).
- d) The following do not contribute to the extent of unprotected area:
 - 1) any part of an external wall of a stairway in a protected shaft;
 - 2) parts of the external wall of an uncomparted building that are more than 30 m above mean ground level;
 - 3) small unprotected areas in an otherwise protected façade according to the constraints shown in Figure 21.
- e) Where a building is provided with automatic sprinklers in accordance with BS 9251:2014 or BS EN 12845 (see 11.2, Table 2), the amount of unprotected area may be doubled or the distance to the boundary for a given amount of unprotected area may be halved.

NOTE Small unprotected areas pose a negligible risk of fire spread.

Figure 20 Combustible surface material as unprotected area

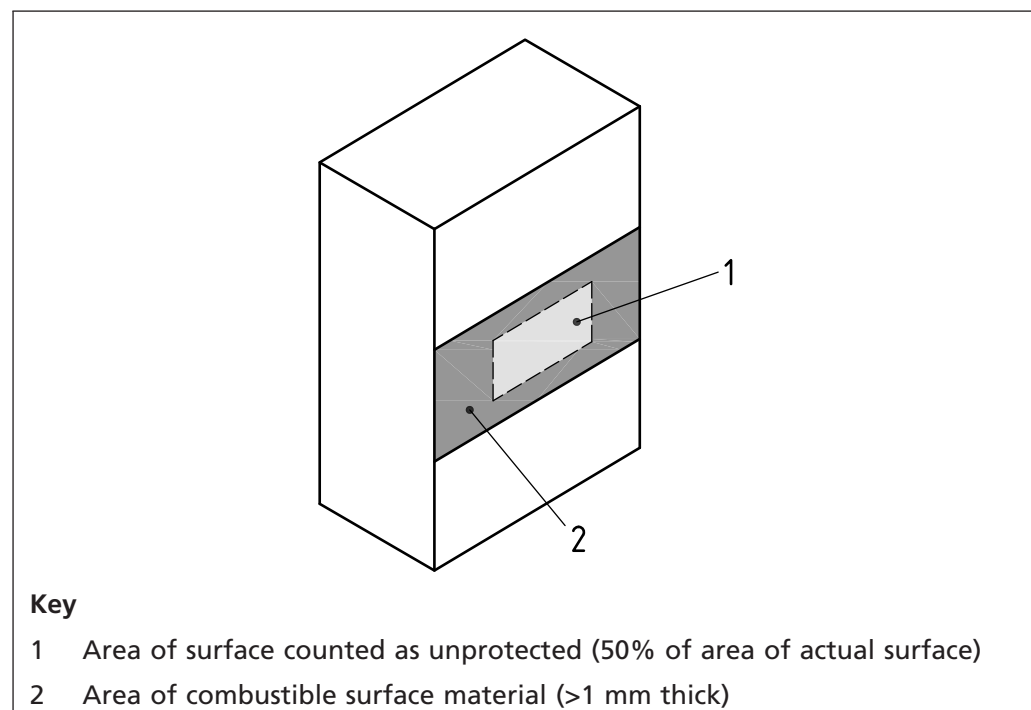
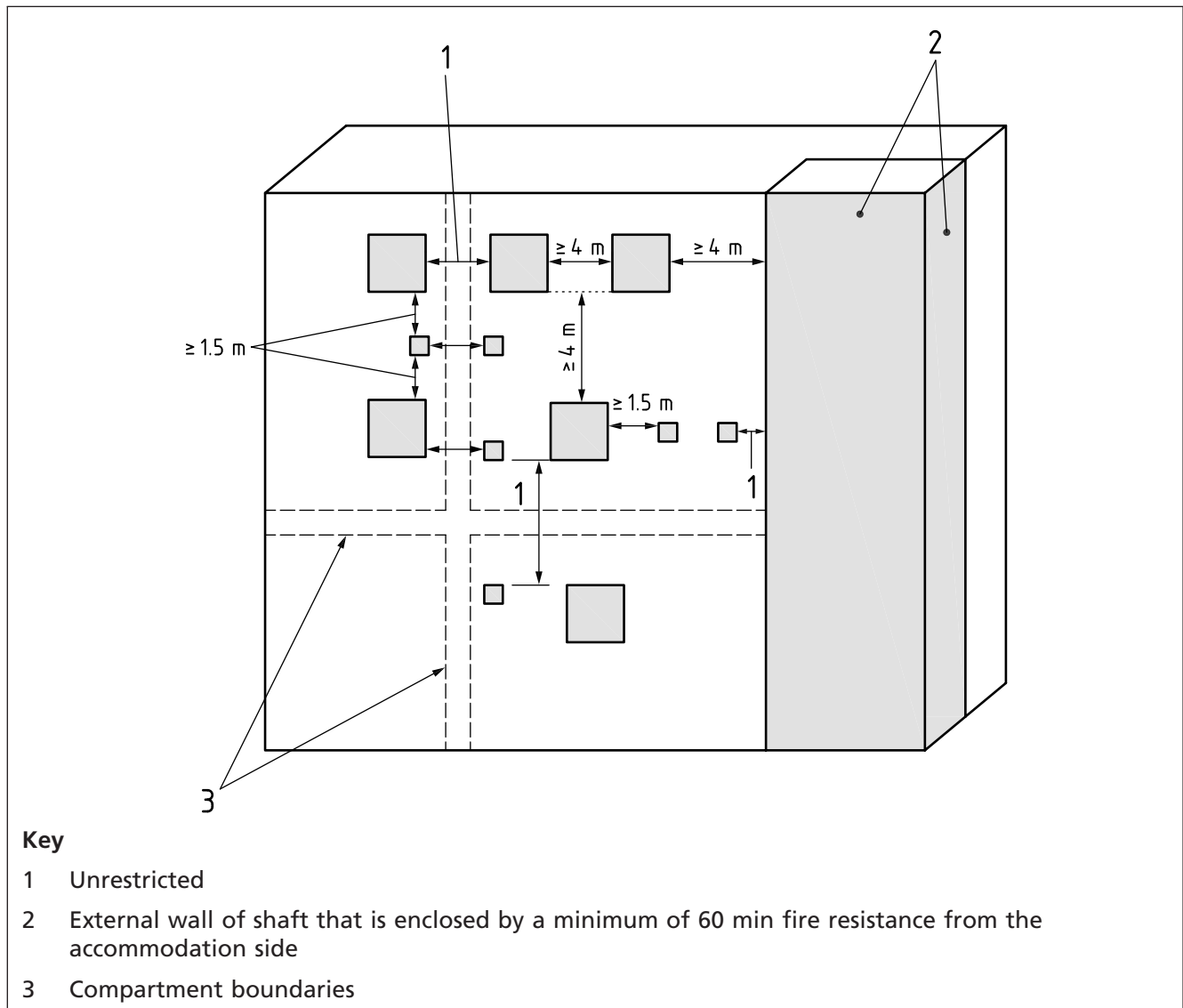

Figure 21 Exclusions from unprotected area calculations



18.5 Degree of separation

18.5.1 General

NOTE 1 Separation distances between a roof and a relevant boundary are covered in 18.6.

A building should be separated from the relevant boundaries by at least half the distance at which the total thermal radiation intensity, received from all unprotected areas in the external façade, would be 12.6 kW/m^2 .

NOTE 2 The intensity of radiation to cause ignition of wood in still air conditions is 12.6 kW/m^2 . Ignition inside a receiver building is dependent on the amount of unprotected area in its façade.

NOTE 3 The use of distance to a relevant boundary, rather than to another building, allows development on the neighbouring site without prejudice.

18.5.2 External walls within 1 m of the relevant boundary

Where an external wall is coincident with (see Figure 17) or within 1 m distance of a relevant boundary it should:

- a) achieve the appropriate level of fire resistance in terms of integrity and insulation (see Table 3) from both sides when tested in accordance with BS 476-22 or BS EN 1634-1;
- b) have only small, unprotected areas within the limits shown in Figure 20;
- c) resist direct flame impingement and high levels of radiation from the adjoining site;
- d) have non-combustible surfaces;
- e) be an effective barrier to a fire either inside or outside the building.

NOTE 1 These recommendations are aimed at protecting neighbouring buildings from direct flame impingement as well as radiation.

NOTE 2 See 18.2 for external wall materials and construction.

18.5.3 External walls 1 m or more from the relevant boundary

Where a wall is situated at least 1 m from all points on the relevant boundary:

- a) the extent of unprotected area should not exceed that given by one of the appropriate methods in 18.5.4;
- b) the rest of the wall (if any) should have the fire resistance stated in Table 4 or Table 5 (with 15 min in terms of insulation).

If a building has an automatic sprinkler system, the incidence of radiation to adjoining buildings can be much reduced. However, if a building is not sprinklered, or if property protection is a consideration, the proportion of external wall that is not fire-resisting should be limited according to the distance to the relevant boundary and the likely intensity of the fire.

18.5.4 Calculation methods

One of the following four methods should be used to determine the maximum permissible amount of unprotected area between a building and a relevant boundary.

- a) **Small residential.** Table 7 should be used to determine the appropriate boundary separation distance when the building is intended for residential use and is:
 - 1) no greater than 3 storeys in height; and
 - 2) no more than 24 m in length.
- b) **Enclosing rectangles.** For details of this method refer to part 1 of BRE Report 187 [21].
- c) **Aggregate notional area.** For details of this method refer to part 1 of BRE Report 187 [21].
- d) **Fire engineering calculation (see BS 7974).** This can be used for small residential unprotected area limits and boundary distances.

Table 7 Small residential unprotected area limits and boundary distances

Minimum distance between façade and relevant boundary m	Maximum total unprotected area per compartment m ²
1	5.6
2	12
3	18
4	24
5	30
6	No limit

18.6 Roofs

COMMENTARY ON 18.6

The recommendations in this subclause are principally concerned with the performance of roofs when exposed to fire from the outside. They limit the use, near a boundary, of roof coverings that are unlikely to give adequate protection against the spread of fire over them. The term "roof covering" is used to describe a construction that may consist of one or more layers of material, but does not refer to the roof structure as a whole.

Relevant test methods for the external fire performance of roof systems are BS 476-3 and DD ENV 1187:2002, Test 4.

For restriction of fire spread over roofs the properties of a roof covering are only of relevance:

- a) if the roof is close enough to a boundary to be at risk of ignition from a fire in other buildings; and
- b) in the vicinity of a compartment wall, to avoid fire spread between compartments via a roof covering (see Figure 22).

Figure 22 Roof covering adjoining line of compartmentation

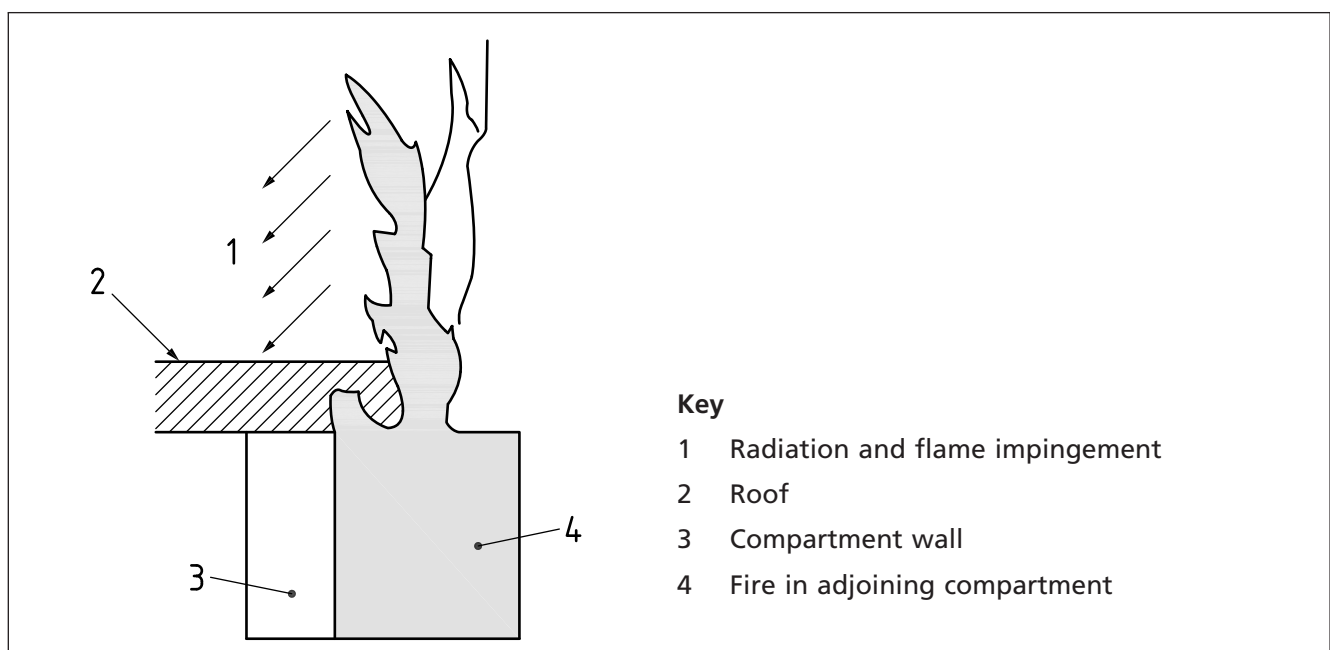

NOTE 1 The circumstances when a roof is subject to the provisions for space separation are explained in Clause 18, Note 1.

NOTE 2 Subclause 18.6.2 gives recommendations for the internal surfaces of roof lights as part of the internal lining of a room or circulation space.

NOTE 3 Recommendations relating to roofing materials are given in 20.4.

18.6.1 Separation distances

The separation distance is the minimum distance from the roof (or part of the roof) to the relevant boundary, which may be a notional boundary. Separation distances should be as recommended in Table 8 for the appropriate type of roof covering and building use.

Table 8 Separation distances for roof coverings

Designation of covering of roof or part of roof ^{A)}	Distance of roof from any point on relevant boundary			
	Less than 6 m	At least 6 m	At least 12 m	At least 20 m
AA, AB or AC	Acceptable	Acceptable	Acceptable	Acceptable
BA, BB or BC	Not acceptable	Acceptable	Acceptable	Acceptable
CA, CB or CC	Not acceptable	Acceptable ^{B), C)}	Acceptable ^{B)}	Acceptable
AD, BD (or CD ^{B)})	Not acceptable	Acceptable ^{C)}	Acceptable	Acceptable
DA, DB, DC (or DD ^{B)})	Not acceptable	Not acceptable	Not acceptable	Acceptable ^{C)}

NOTE 1 Unwired glass at least 4 mm in thickness has an AA designation.

NOTE 2 See Table 9 for limitations on plastic roof lights.

^{A)} The performance of roof coverings is designated by reference to the test methods given in BS 476-3 (or DD ENV 1187).

^{B)} Not acceptable on buildings with a volume of more than 1 500 m³.

^{C)} Acceptable on buildings not listed in Footnote B, if part of the roof is no more than 3 m² in area and is at least 1.5 m from any similar part, with the roof between the parts covered with a material of limited combustibility.

18.6.2 Roof lights

The separation distance for plastic roof lights should be as recommended in Table 9 for the appropriate classification (see also Figure 23). Roof lights should be at least 1.5 m from a compartment wall.

Plastic roof lights should not be used in protected stairways.

NOTE 1 When used in roof lights, a rigid thermoplastic sheet product made from polycarbonate or from unplasticized PVC, which achieves a Class 1 rating for surface spread of flame when tested in accordance with BS 476-7 or the European equivalent, is deemed to have an AA designation.

The roof covering material surrounding a plastic roof light should be of limited combustibility for at least 3 m distance.

NOTE 2 The designation of external roof surfaces is defined in BS 476-3.

Products may have upper and lower surfaces with different properties if they have double skins or are laminates of different materials, in which case the more onerous distance should be assumed.

NOTE 3 The method of classifying thermoplastic materials is given in BS 9999.

Table 9 Separation distance for plastic roof lights

Space that roof light can serve	Min. classification on lower surface ^{A)}	Dimensions in metres			
		Min. distance from any point on relevant boundary to roof light			
		Class 3 plastic roof lights		TP(a) and TP(b) plastic roof lights	
		AD, BD, CA, CB, CC, CD	DA, DB, DC, DD	TP(a)	TP(b)
Balcony, veranda, carport, covered way or loading bay, which has at least one longer side wholly or permanently open	Class 3	6	20	—	—
	TP(b)	—	—	N/A	6
Detached swimming pool	Class 3	6	20	—	—
	TP(b)	—	—	N/A	6
Conservatory, domestic garage or outbuilding, wholly or permanently open with a maximum floor area of 40 m ²	Class 3	6	20	—	—
	TP(b)	—	—	N/A	6
Circulation space ^{B)} (except a protected stairway)	Class 3	6	20	—	—
	TP(b)	—	—	N/A	6
Room ^{B)}	Class 3	6 ^{C)}	20 ^{C)}	—	—
	TP(b)	—	—	N/A	6 ^{C)}
Any space except a protected stairway	TP(a) rigid	—	—	6	N/A

^{A)} See also the limits in Table 8.

^{B)} Single skin roof light only, in the case of non-thermoplastic material.

^{C)} The roof light should also not exceed the limitations shown in Figure 23.

Figure 23 Limitations on spacing and size of plastic roof lights having a Class 3 or TP(b) lower surface

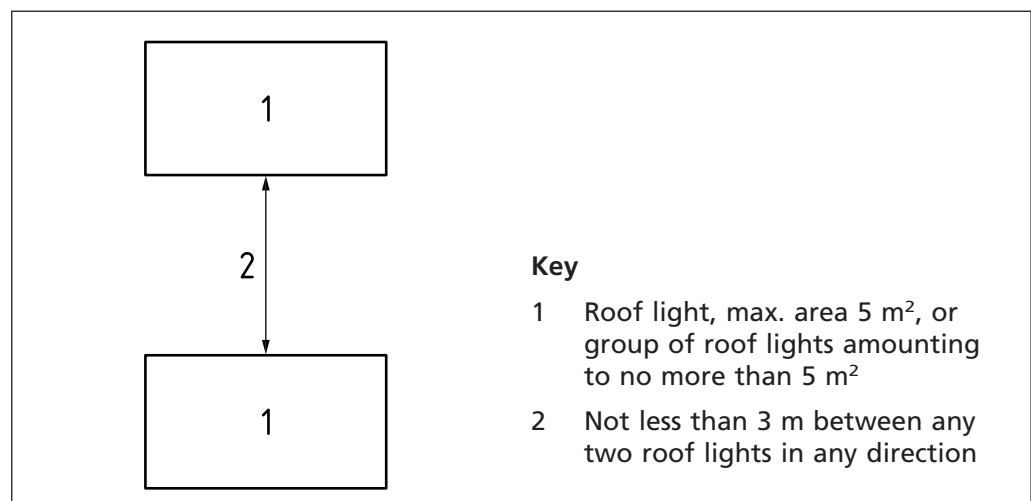

19 Concealed spaces

COMMENTARY ON CLAUSE 19

Concealed spaces or cavities in the construction of a building provide a ready route for smoke and flame spread. This is particularly so in the case of voids in, above and below the construction of a building, e.g. walls, floors, ceilings and roof spaces.

As any spread of fire or smoke is concealed, it presents a greater danger than would a more obvious weakness in the fabric of the building. Provisions can be made to restrict this by interrupting cavities which could form a pathway around a barrier to fire, subdividing extensive cavities, and closing the edges of openings.

The unseen spread of fire or smoke via voids and cavities can be a threat to occupants if it bypasses compartment boundaries or elements protecting the means of escape.

It can also be a threat to fire-fighters in large spaces if it leads to the obstruction of their line of retreat.

A cavity in an external wall can behave as a chimney, accelerating fire spread up a façade. This can be a threat to occupants or fire-fighters if the cavity is open to the exterior. Sealed cavities are generally not a problem.

Recommendations for cavity barriers are given in this clause for specific locations. The provisions necessary to restrict the spread of smoke and flames through cavities are broadly for the purpose of subdividing cavities, which could otherwise form a pathway around a fire-separating element and closing the edges of cavities, therefore reducing the potential for unseen fire spread. (These are not to be confused with fire-stopping details; see 24.4 and Figure 24.)

It is also necessary to take into account the construction and fixing of cavity barriers provided for these purposes and the extent to which openings in them need to be protected (see 19.1).

19.1 Provision of cavity barriers

19.1.1 Junctions and compartment walls

Cavity barriers should be provided to close the edges of cavities, including around openings.

Cavity barriers should also be provided:

- a) at the junction between an external cavity wall (except where the cavity wall is as shown in Figure 25) and every compartment floor and compartment wall; and
- b) at the junction between an internal cavity wall (except where the cavity wall is as shown in Figure 25) and every compartment floor, compartment wall, or other wall or door assembly which forms a fire-resisting barrier.

It is important to continue any compartment wall up through a ceiling or roof cavity to maintain the standard of fire resistance, therefore compartment walls should be carried up full storey height to a compartment floor or to the roof as appropriate. It is therefore not appropriate to complete a line of compartmentation by fitting cavity barriers above the compartment wall.

Figure 24 Provisions for cavity barriers

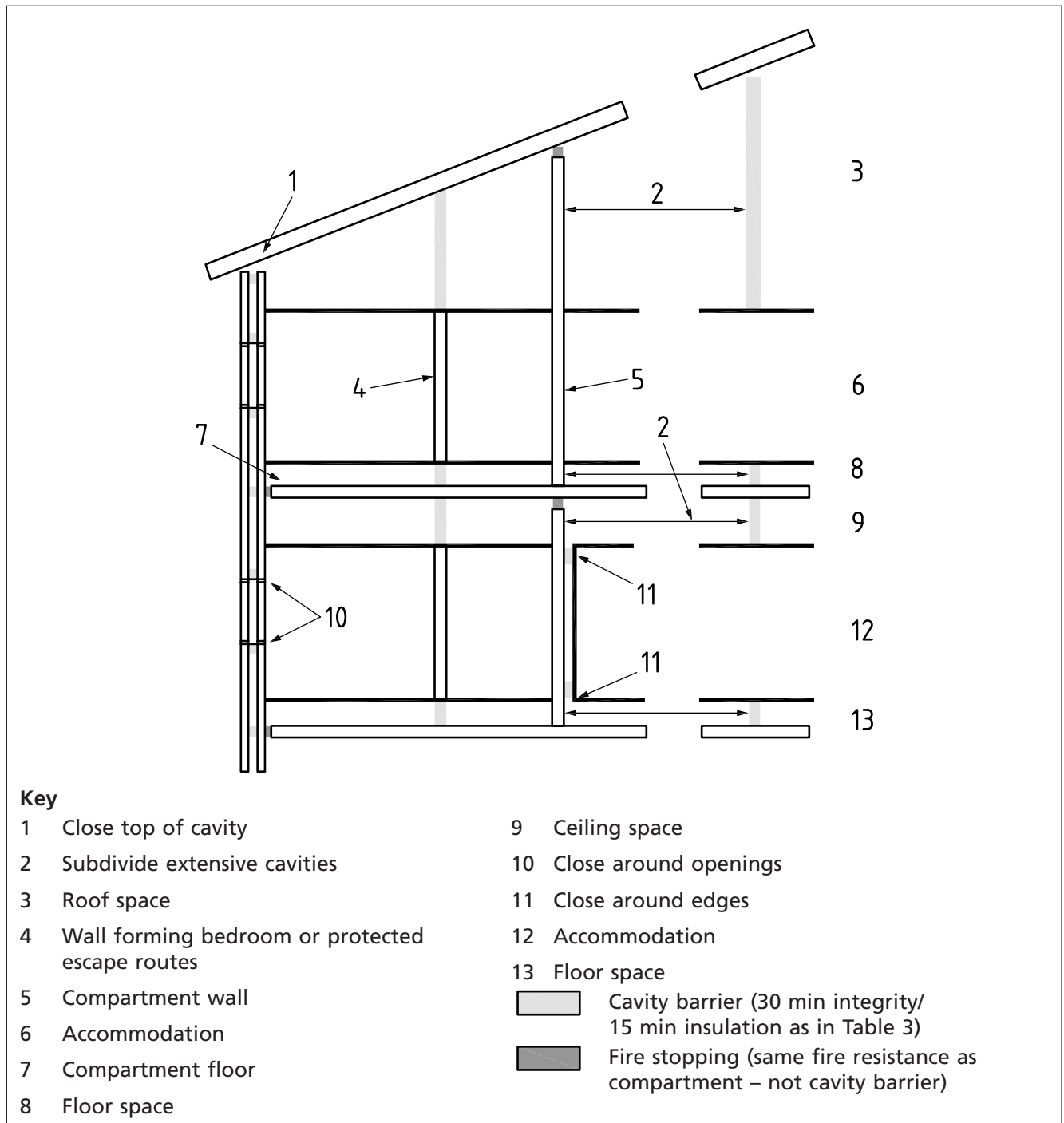
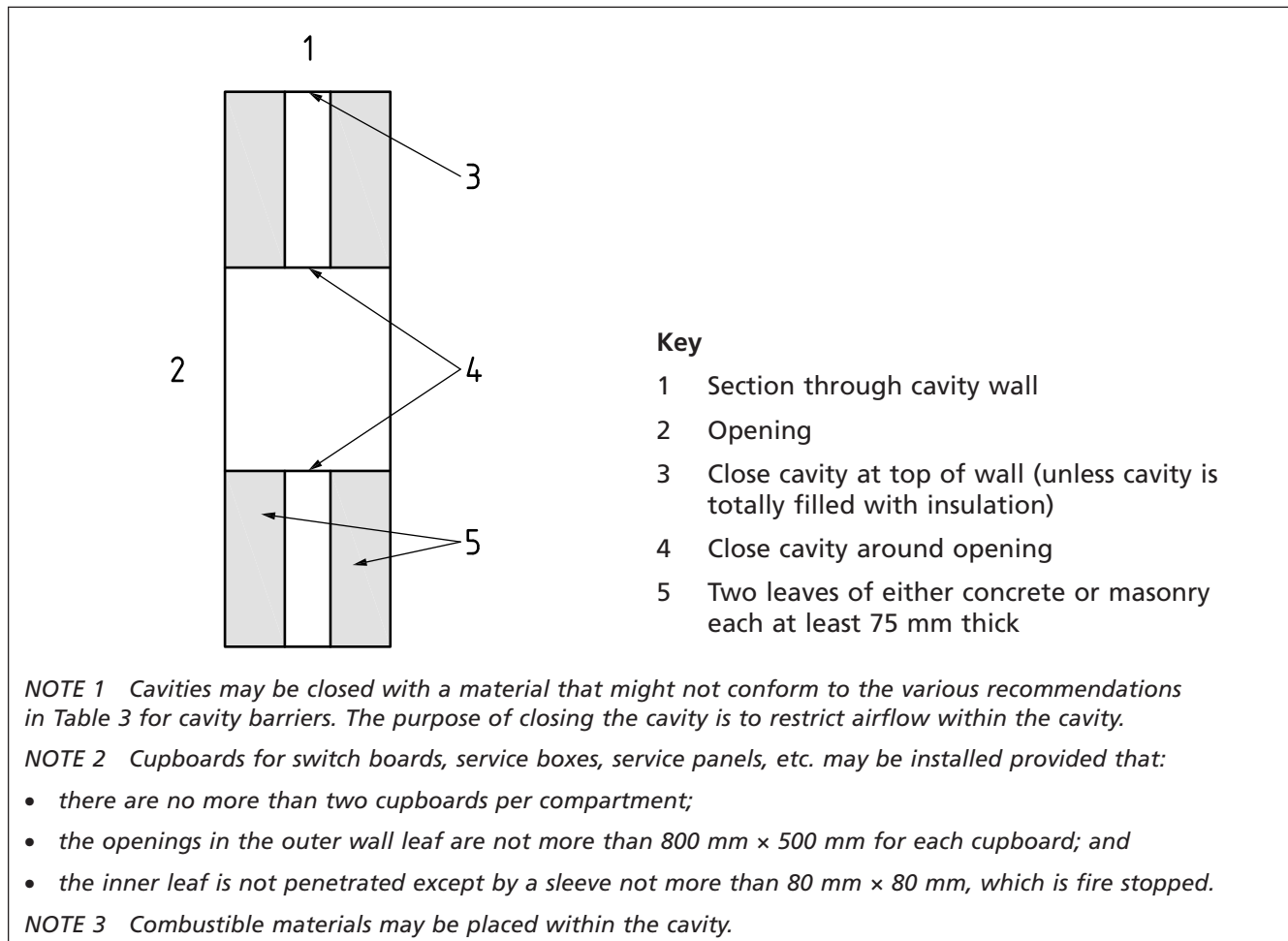

Figure 25 Cavity wall excluded from provisions for cavity barriers



19.1.2 Protected escape routes

For a protected escape route, a cavity that exists above or below any fire-resisting construction because the construction is not carried to full storey height or, in the case of a top storey, to the underside of the roof covering, should be either:

- a) fitted with cavity barriers on the line of the enclosure(s) to the protected escape route; or
- b) for cavities above the fire-resisting construction, enclosed on the lower side by a fire-resisting ceiling having fire-resistance tested in accordance with the applicable parts of BS 476 for exposure above and below the ceiling and which extends throughout the building, compartment or separated part (see Figure 26).

Figure 26 Fire-resisting ceiling below concealed space

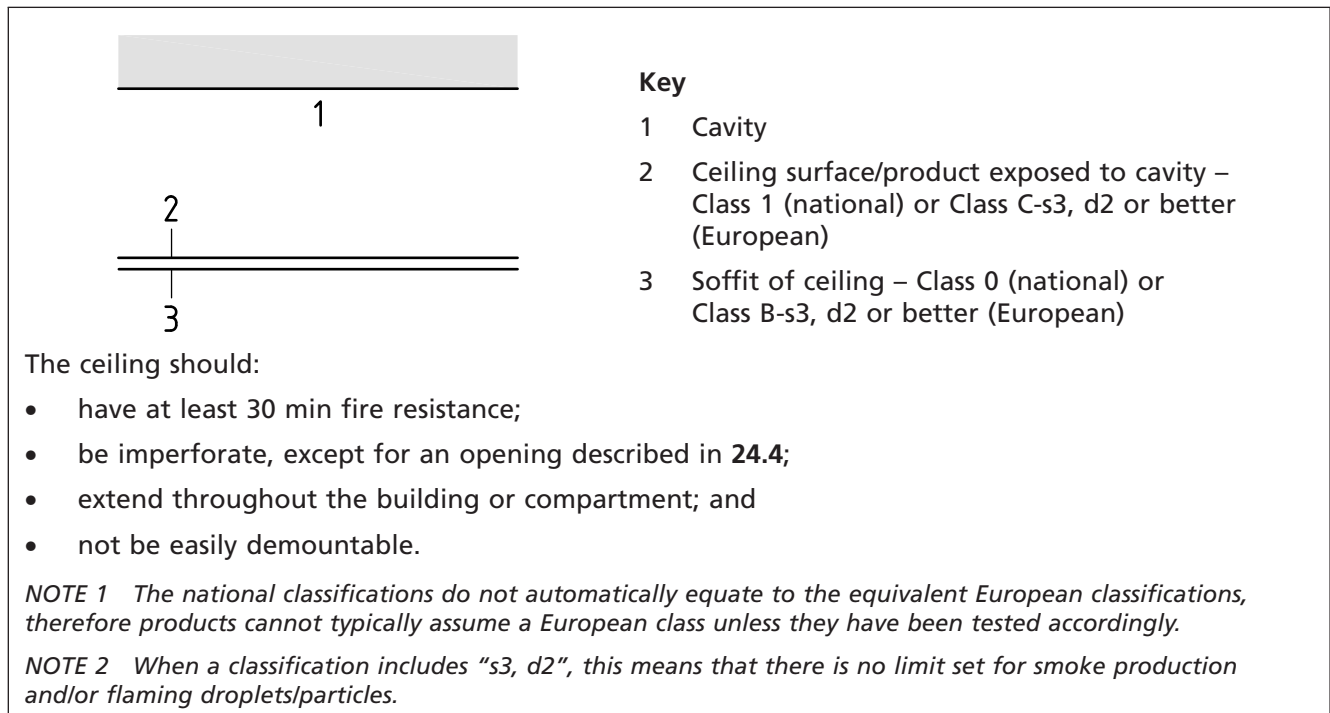

19.1.3 Double-skinned corrugated or profiled roof sheeting

Where double-skinned corrugated or profiled insulated roof sheeting is used, cavity barriers should be provided unless:

- a) the sheeting is a material of limited combustibility; and
- b) both surfaces of the insulating layer have a surface spread of flame of at least Class 0 or 1 (national) or Class C-s3, d2 or better (European) and make contact with the inner and outer skins of cladding (see Figure 27).

NOTE When a classification includes “s3, d2”, this means that there is no limit set for smoke production and/or flaming droplets/particles.

A compartment wall should be taken up to meet the underside of the roof covering or deck, with fire-stopping where necessary at the wall/roof junction to maintain the continuity of fire resistance.

Figure 27 Provisions for cavity barriers in double skinned insulated roof sheeting

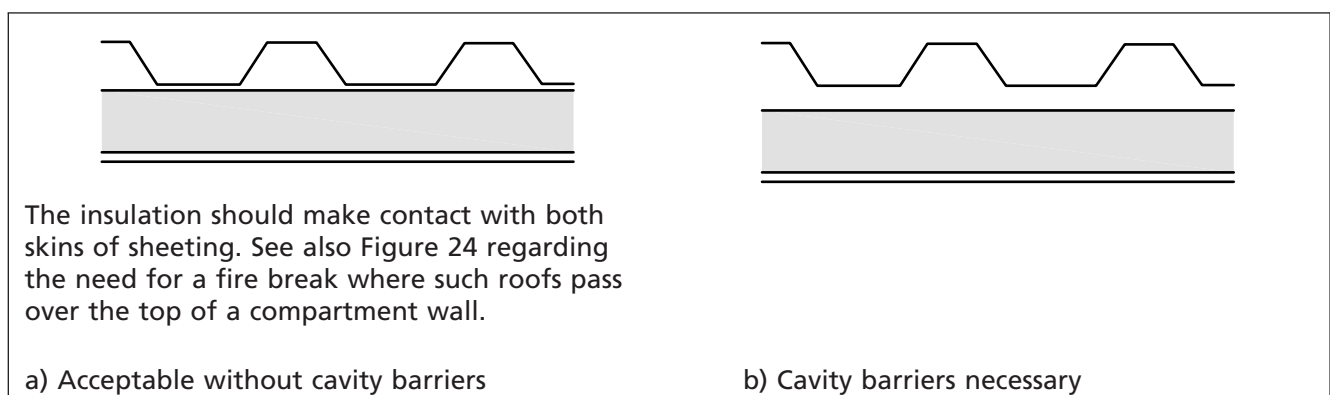

19.1.4 Cavities affecting alternative escape routes

Where deemed necessary, cavity barriers should be provided where corridors are to be subdivided to prevent alternative escape routes being simultaneously affected by fire and/or smoke.

19.1.5 Separation of bedrooms

A cavity that exists above or below partitions between bedrooms because the enclosures are not carried to full storey height, or (in the case of the top storey) to the underside of the roof covering, should be either:

- a) fitted with cavity barriers on the line of the partitions; or
- b) for cavities above the partitions, enclosed on the lower side by a fire-resisting ceiling which extends throughout the building, compartment or separated part.

19.2 Construction and fixings for cavity barriers

Every cavity barrier should be constructed to provide at least 30 min fire resistance. It may be formed by any construction provided for another purpose if it meets the provisions for cavity barriers (see Table 4). Cavity barriers in a stud wall or partition, or provided around openings, may be formed of:

- a) steel at least 0.5 mm thick;
- b) timber at least 38 mm thick;
- c) polythene-sleeved mineral wool, or mineral wool slab, in either case under compression when installed in the cavity; or
- d) calcium silicate, cement-based or gypsum-based boards at least 12 mm thick.

NOTE 1 Cavity barriers provided around openings may be formed by the window or door frame if the frame is constructed of steel or timber of the minimum thickness in a) or b) above as appropriate.

A cavity barrier should, wherever possible, be tightly fitted to a rigid construction and mechanically fixed in position. Where this is not possible (e.g. in the case of a junction with slates, tiles, corrugated sheeting or similar materials) the junction should be fire-stopped in accordance with **24.4**.

Cavity barriers should also be fixed so that their performance is unlikely to be made ineffective by:

- 1) movement of the building due to subsidence, shrinkage or temperature change and movement of the external envelope due to wind; or
- 2) collapse in a fire of any services penetrating them; or
- 3) failure in a fire of their fixings (but see Note 2); or
- 4) failure in a fire of any material or construction which they abut. (For example, if a suspended ceiling is continued over the top of a fire-resisting wall or partition and direct connection is made between the ceiling and the cavity barrier above the line of the wall or partition, premature failure of the cavity barrier can occur when the ceiling collapses. However, this might not arise if the ceiling is designed to provide fire protection of 30 min or more.)

NOTE 2 Where cavity barriers are provided in roof spaces, the roof members to which they are fitted are not expected to have any fire resistance for the purpose of supporting the cavity barrier(s).

Any openings in a cavity barrier should be limited to those for:

- i) doors which have at least 30 min fire resistance (see **24.1**) and are fitted in accordance with the provisions of **24.1**;
- ii) the passage of pipes which meet the provisions in **24.4**;
- iii) the passage of cables or conduits containing one or more cables;
- iv) openings fitted with a suitably mounted automatic fire damper (see BS 9999); and

- v) ducts which (unless they are fire-resisting) are fitted with a suitably mounted automatic fire damper where they pass through the cavity barrier.

If a cavity barrier is provided above a partition separating bedrooms in accordance with 19.1.5 which do not need to be fire-resisting partitions then i) to v) need not apply. However, openings in the barrier should be kept to a minimum and any penetrations should be sealed to restrict the passage of smoke.

20 Materials

NOTE Materials chosen because of their ability not to support surface spread of flame (i.e. limited or zero combustibility) are not to be taken to be fire-resistant unless the materials have been specifically classified by testing for that property.

20.1 Internal linings

Although they are unlikely to be the first materials to ignite, the choice of materials for wall and ceilings can significantly affect the spread of a fire and its rate of growth and should be selected carefully. In particular, internal linings selected for circulation spaces should have non-flammable characteristics that can delay the spread of fire, so that the occupants' means of escape is not compromised.

The internal linings within circulation spaces within dwellings should either conform to Class 1 surface spread of flame in accordance with BS 476-7, when tested in accordance with BS 476-6, or conform to Class C-s3, d2 when tested in accordance with BS EN 13501-1.

The internal linings within other circulation spaces, including the common areas of blocks of flats, should meet Class 0 (national) or Class B-s3, d2 (European).

Small rooms of area not more than 4 m² should have internal linings conforming to Class 3 (national) or Class D-s3, d2 (European).

NOTE Further guidance on the classification of linings together with limitations on their use is given in BS 9999.

20.2 Suspended or stretched-skin ceilings

The ceiling of a room should be constructed as either a suspended or a stretched skin membrane from panels of a thermoplastic material of the TP(a) flexible classification, unless it is part of a fire-resisting ceiling. Each panel should not exceed 5 m² in area and should be supported on all its sides.

20.3 Non-combustible materials

Non-combustible materials should be used in the following situations:

- a) ladders forming part of an escape route in ancillary accommodation identified as higher fire risk;
- b) refuse chutes;
- c) suspended ceilings and their supports where the undivided cavity exceeds 40 m in extent;
- d) as a sleeving where a pipe penetrates a compartment wall or floor;
- e) walls of a flue that penetrates a compartment floor or wall;
- f) construction of an open-sided car park.

20.4 Special roof coverings

NOTE 1 Special roofing types include:

- a) *air-supported structures;*
- b) *flexible membrane roofs;*
- c) *PTFE-coated roof membranes.*

Any flexible membrane covering a structure, other than an air-supported structure, should conform to BS 7157:1989, Annex A.

NOTE 2 Guidance on the use of PTFE-coated materials for tension membrane and similar roofs and structures is given in BRE Report 274 [22].

21 Service ducts, pipes and shafts

21.1 Service shafts

Lift wells (other than within a protected stairway) should be enclosed throughout their height with fire-resisting construction.

Service shafts and other vertical ducts should be enclosed throughout their height with fire-resisting construction. Service ducts should be in accordance with BS 8313, and ventilation and air conditioning ductwork should be in accordance with 21.2. Access hatches for service shafts should not be situated within a means of escape staircase unless providing smoke control or pressurization for that staircase.

NOTE The penetration of fire-resisting floors by services and vertical shafts can reduce the safety of occupants and create points of weakness in the compartmentation of the building.

Wherever practicable, services should not be run within common access corridors, including the corridor access for fire-fighting shafts. Where this is unavoidable, they should be run in a fire-separating construction or in a secured fire-resisting method.

The doors should be fitted with secure fastenings to discourage the use of the riser for storage (budget locks, etc.).

21.2 Installation of ductwork systems

When ductwork systems are installed within a building it is important that the ductwork does not assist in transferring fire and smoke through the building and put at risk the protected means of escape from the accommodation areas. Any exhaust points should be sited so as not to further jeopardize the building in the event of a fire, i.e. away from final exits, combustible building cladding or roofing materials, and openings into the building.

Ventilation ducts, and their associated plant supplying or extracting air directly to or from a protected escape route, should not also serve other areas. A separate ventilation system should be provided for each protected stairway.

Where a ductwork system serves more than one part of a compartment or fire-separated protected escape route, smoke detector operated fire dampers should be provided where ductwork enters each fire-separated or smoke-separated section of the escape route.

NOTE 1 Further details on the installation, fire resistance, operation and actuation of fire dampers are given in BS 9999.

The smoke detector operated fire dampers should be caused to close if smoke is detected. Any ductwork passing through an accommodation space should be fire-resisting, i.e. the ductwork should be protected using fire-resisting enclosures or fire-resisting ductwork.

Any ductwork passing through a protected stairway, lobby or corridor without an opening into that area should be fire-resisting, i.e. the ductwork should be protected using fire-resisting enclosures or fire-resisting ductwork.

NOTE 2 Further information on the design of ductwork fire protection is given in BS 9999.

In single stairway buildings, the ductwork enclosure should be imperforate where it passes through the stairway or any protected lobby or protected corridor.

In multi-stairway buildings, ductwork access panels within protected escape routes should not reduce the fire resistance of the ductwork enclosure from the inside.

Where a service duct enclosure is provided with a level of fire resistance in accordance with BS 8313, and the service duct itself is also used for ventilation purposes, any grille or opening through the enclosure for ventilation purposes should be protected by a fire damper.

NOTE 3 See also BS 9999 for information and recommendations regarding air transfer grilles.

Service pipes containing toxic or flammable substances should not be routed in, or through, ductwork provided for ventilation purposes.

21.3 Flues

If a flue, or duct containing flues or appliance ventilation duct(s), passes through a compartment wall or compartment floor or is built into a compartment wall, each wall of the flue or duct should have a fire resistance of at least half that of the wall or floor (see Figure 28).

21.4 Protection of pipe openings

COMMENTARY ON 21.4

Pipework that breaches compartment walls and compartment floors can compromise compartmentation if fire protection is not provided to the pipework. Pipes may be constructed from many different materials and all these materials behave differently in a fire situation. The size of the opening is a major factor in the spread of heat and flame and therefore needs to be restricted when a pipe breaches a compartment wall or compartment floor.

Pipes that pass through a compartment wall or compartment floor (unless the pipe is in a protected shaft), or through a cavity barrier, should be in accordance with one of the following alternatives.

- a) For proprietary seals of any pipe diameter, a proprietary sealing system may be provided that has been shown by test to maintain the fire resistance of the wall, floor or cavity barrier.
- b) For pipes with a restricted diameter, where a proprietary sealing system is not used, fire-stopping may be used around the pipe (see 24.4), keeping the opening as small as possible. The nominal interior diameter of the pipe should be not more than the relevant dimensions given in Table 10 (see also Figure 29).
- c) A pipe of lead, aluminium, aluminium alloy, fibre-cement or PVC, with a maximum nominal diameter of 160 mm, may be used with a sleeving of non-combustible pipe as shown in Figure 30.

Tests carried out in accordance with BS EN 1366-3 are specific to service penetrations. Ad hoc tests should be used only where directly relevant to the application.

Figure 28 Flues and compartment walls and floors

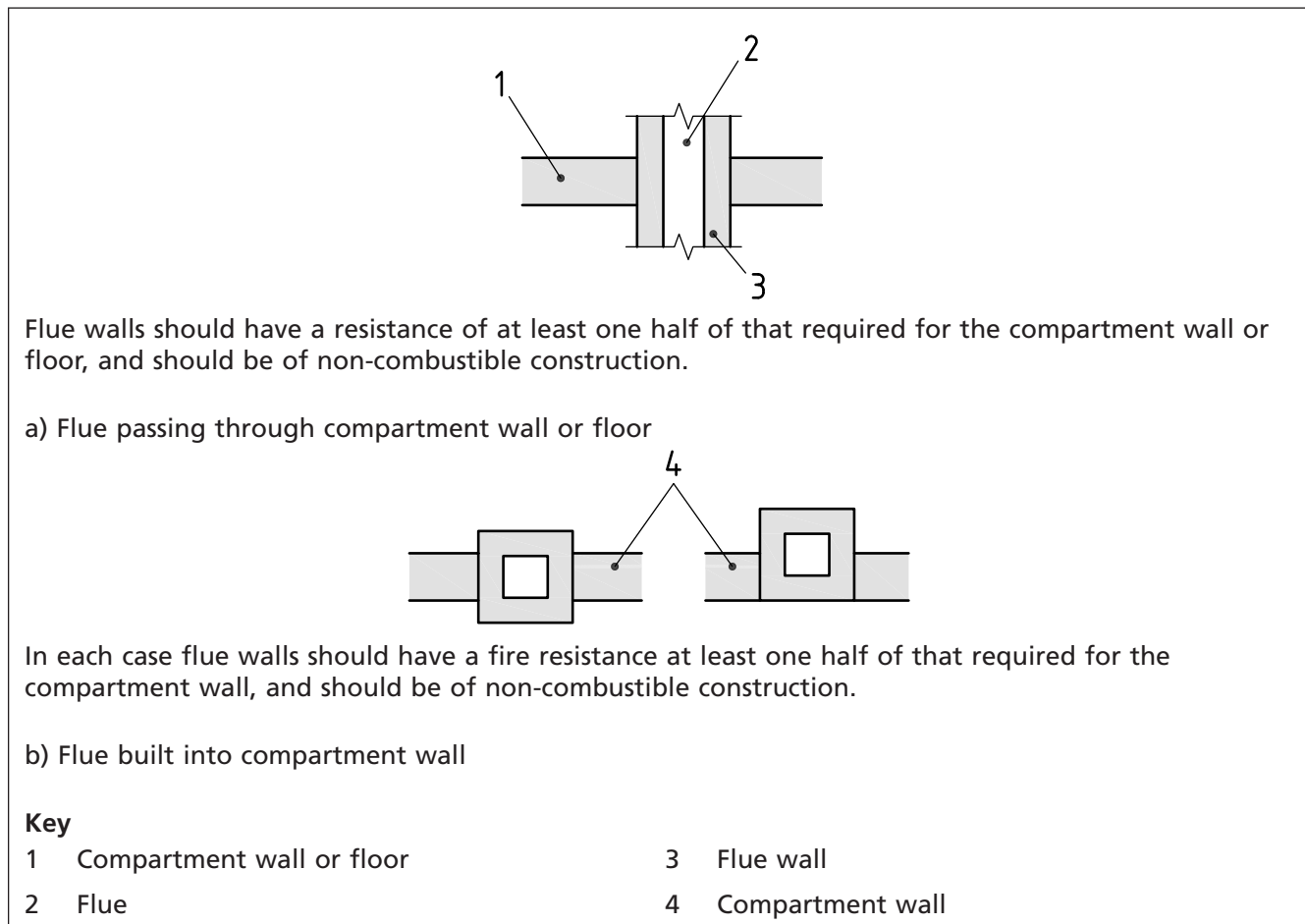

Table 10 Maximum nominal interior diameter of pipes passing through a compartment wall/floor

Situation	Dimensions in millimetres		
	Maximum nominal internal diameter		
	a) Non-combustible material ^{A)}	b) Lead, aluminium, aluminium alloy, PVC ^{B)} , fibre-cement	c) Any other material
1) Structure (but not a wall separating buildings) enclosing a protected shaft which is not a stairway or a lift well	160	110	40
2) Compartment wall or compartment floor between flats	160	160 (stack pipe) ^{C)} 110 (branch pipe) ^{C)}	40
3) Any other situation	160	40	40

^{A)} A non-combustible material (such as cast iron or steel) which, if exposed to a temperature of 800 °C, does not soften or fracture to the extent that flame or hot gas passes through the wall of the pipe.

^{B)} uPVC pipes conforming to BS 4514 and uPVC pipes conforming to BS 5255.

^{C)} These diameters are only in relation to pipes forming part of an above-ground drainage system and enclosed as shown in Figure 29. In other cases the maximum diameters against situation 3) apply.

Figure 29 Enclosure for drainage or water supply pipes

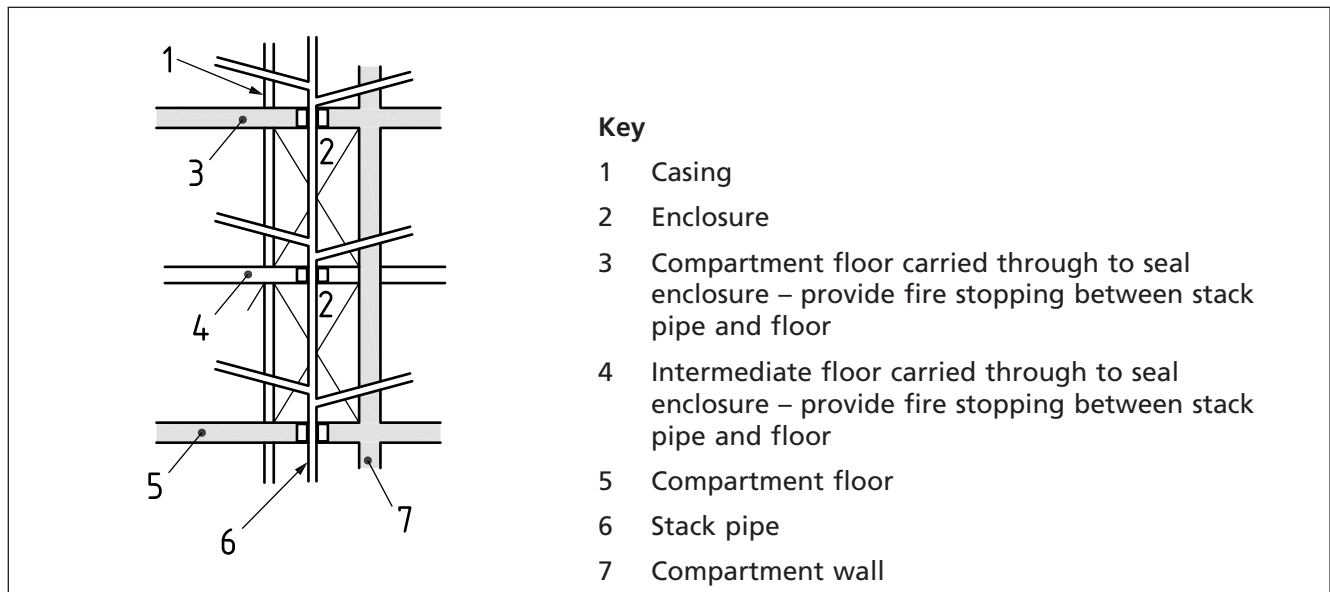
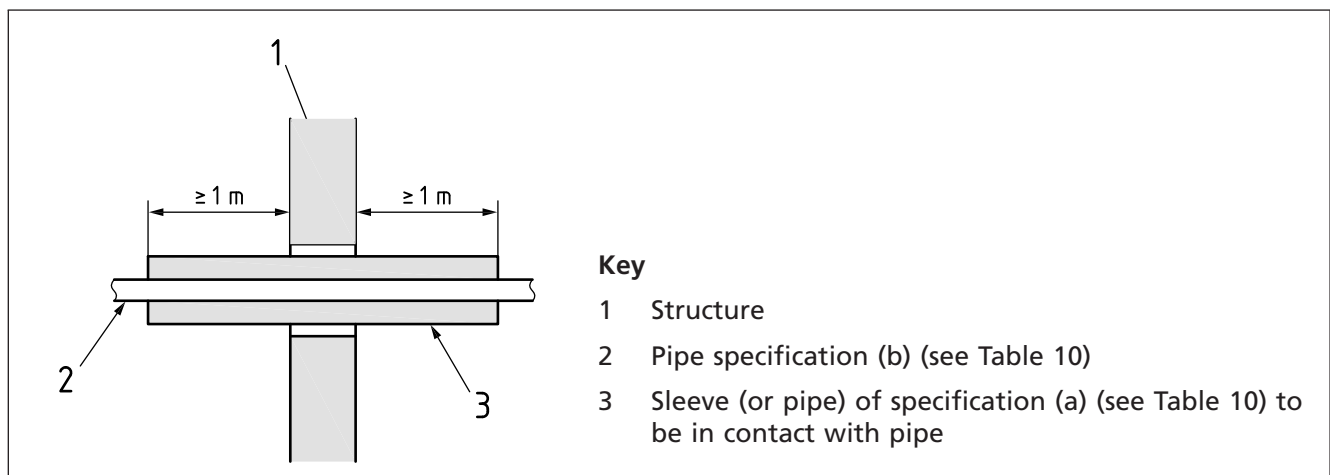

Figure 30 Pipes penetrating structure



22 Glazed fire-resisting elements

COMMENTARY ON CLAUSE 22

The fire resistance of a fire-resisting glazed assembly is influenced by a number of factors, such as:

- a) type of glass and function;
- b) pane size and shape;
- c) glazing layout and number of panes;
- d) orientation of the glazed element;
- e) framing and framing junctions;
- f) glazing seal;
- g) beads and bead fixings; and
- h) fixing of the assembly to the support structure.

Guidance on these factors is given in the GGF publication *A guide to best practice in the specification and use of fire-resistant glazed systems* [23].

The class of fire resistance of the glazed element (i.e. either integrity or insulation, and a classification time in minutes) used in a fire-resistant construction depends on whether:

- 1) the glazed element is there to provide the same level of protection as the remainder of the enclosure in which it is situated to act as a barrier to fire spread (usually insulation); or*
- 2) it is sufficient for the glazed element to provide protection against the passage of flames and hot gases (i.e. integrity, non-insulation performance) sufficient for the purpose of protected escape.*

22.1 General

Fire-resisting glass should be used only as part of an approved glazed system of matched components based on fire resistance testing of each individual system. Unauthorized changes should not be made to the list of glazed components in each case, and the system should be installed according to the assembly and glazing arrangement as tested.

The level of fire resistance of a representative example of the glazed system should be tested in accordance with BS 476-22 or classified in accordance with BS EN 13501-2.

NOTE 1 Where the test evidence is not exactly the same as the glazed element to be installed (e.g. where the proposed glass size is greater than that tested) then a Notified Body, or an otherwise appropriately qualified body, might be able to undertake an assessment based on test evidence, or an extended application in accordance with the relevant CEN EXAP standard.

Assessments should be based only on relevant and applicable test evidence for the system under consideration. The proposed glazing design should be within the scope of the available test evidence and the system should be specified and installed as tested and classified. There should be no changes in tested components unless authorized by the responsible glazing manufacturer.

For façade design, fire-resisting glazed elements may be used at appropriate locations to minimize the risk of fire spread in the same building from floor to floor, or on the same floor across re-entrant corners, by preventing flame break-out and break-in. The distance for the application of fire-resisting glazing either side of such a re-entrant corner, or on either side of a protected stairway with an external glazed wall, should be 1 800 mm.

NOTE 2 Recommendations for enclosure of common stairs are given in Clause 29.

NOTE 3 Specific guidance for all-glass constructions in atria is given in BS 9999.

Where applicable, fire-resisting glazing systems should conform to BS 6262-4 for impact safety, BS 6180 if used in a barrier, and the relevant part of BS 5234 if used in a partition.

All fire-resisting glass should be marked, as a minimum, with an identifiable name or trademark, or other mark, capable of unambiguous identification to the manufacturer or supplier (e.g. a product name, manufacturer's name or code). Installations should be in accordance with glazing guidelines provided by the manufacturer, and the glass should be installed in such a way that the identification mark is visible after installation. Appropriate documentation to confirm the system level of fire resistance should be provided on completion of the installation.

22.2 Limitations of non-insulating fire-resisting glazing

COMMENTARY ON 22.2

Restrictions apply to the use of non-insulating fire-resisting glazed elements because of the risks that they pose from their relative inability to provide adequate protection against transmitted heat. There are a number of hazards that could occur even if the integrity of the glazed element as a flame and smoke barrier is maintained. These include:

- *direct exposure to potentially high levels of radiant heat with the risk of burns to exposed skin;*
- *convective heating of the atmosphere in the escape way;*
- *smouldering smoke generation (before ignition) from floor coverings, fixtures and fittings in the corridor;*
- *secondary ignition and flaming of fixtures and fittings in the escape way.*

To minimize the risk of ignition of adjacent floorings or floor coverings, non-insulating glazed areas in fire-resisting structures should be at least 100 mm above floor level.

The risk of smouldering combustion before flaming occurs can be heightened on the nominally protected side of non-insulating glazing under developed fire conditions. The limiting height should therefore, if necessary, be raised above floor level for non-insulated fire-resisting glass (e.g. from 100 mm to at least 500 mm) to minimize the risk of smoke generation in the escape route affecting safe escape or fire-fighter access, depending on the anticipated fire load and escape conditions.

Glazed elements that are fire-resisting in terms of integrity only (i.e. non-insulating) should not exceed the limitations given in Table 11.

In the case of houses, glazed elements that are fire-resisting in terms of integrity only may be used in fire-resisting screens and in door panels and fanlights for fire and smoke separation, on the basis that escape to a place of ultimate safety outside the building is relatively short and direct compared with other building types.

In the case of buildings containing flats or maisonettes, glazed elements that are fire-resisting in terms of integrity only should not exceed the limitations given in Table 11, appropriate to their position for fire and smoke separation, on the basis that escape to a place of ultimate safety outside the building is relatively short and direct compared with other building types.

NOTE For mixed-use buildings, the limitations of non-insulating fire-resisting glazed elements are provided in BS 9999 for those areas not covered in Table 11.

Glazed elements that are fire-resisting in terms of both integrity and insulation to the required level may be used without restriction.

The same principles should be applied when using integrity with insulation fire-resisting glazed elements, instead of integrity only fire-resisting glazed elements, for the protection of property against fire, when fire exposure might be prolonged.

Table 11 Limitations on non-insulating fire-resisting glazed elements installed in buildings containing flats or maisonettes

Position of glazed element	Maximum area of non-insulating glazing	
	Fire-resisting walls ^{A)}	Any leaf of a fire door ^{B)}
Part of the enclosure of a protected entrance hall or protected landing within a flat or maisonette	In fixed fanlights only	Unlimited above 1.1 m in height
Between a flat or maisonette and a protected lobby, a common corridor or a protected stairway	Nil	Nil
Between a protected lobby or common corridor and a common stair	Unlimited above 1.1 m in height	Unlimited above 1.1 m in height
Subdividing corridors	Unlimited above 1.1 m in height	Unlimited above 1.1 m in height
Between a protected lobby or an internal common corridor and a communal lounge, a common amenity area or a low voltage or extra-low voltage service installation room	Unlimited above 1.1 m in height	Unlimited above 1.1 m in height
Between a common stair and ancillary accommodation	Nil	Nil
Between an escape route and a higher fire risk area of ancillary accommodation	Nil	Nil
Between a dwelling and an open access balcony with escape in one direction only	Unlimited above 1.1 m in height	Unlimited above 1.1 m in height

NOTE For considerations of transmitted heat through glazed elements, the use of insulation glazing can significantly reduce the risk of injury to people and of secondary fire transfer.

^{A)} The size of individual panes of glass making up the permitted total glazed area should be limited to sizes that have been satisfactorily demonstrated to conform to the integrity criterion for an appropriate duration under test. Similarly, any mullions or transoms, especially between adjacent glazed elements, should also be proven.

^{B)} The suitability of any door with respect to incorporating fire-resisting glass should be established before glazing. Moreover, not all doors can be glazed without affecting the integrity of the door assembly.

22.3 Glazed screen separating protected shaft from lobby or corridor

A non-insulated fire-resisting glazed screen may be incorporated in the enclosure to a protected shaft between a stair and a lobby or corridor which is entered from the stair provided that the following conditions are satisfied:

- a) the standard of fire resistance for the stair enclosure is not more than 60 min; and
- b) the glazed screen:
 - 1) has at least 30 min fire resistance in terms of integrity; and
 - 2) does not exceed the limits on areas of non-insulated glazing given in Table 11;
- c) the lobby or corridor is enclosed to at least a 30 min standard.

22.4 Glazing and the effects of sprinklers

COMMENTARY ON 22.4

Sprinklers are intended to reduce the growth and the size of a fire. Where the building is protected by sprinklers it might be possible either to reduce the required fire resistance classification period of an element of glazing or to use non-insulated fire-resisting glazing, whilst retaining fire-resistant glazed elements in locations for protected escape as recommended by this standard.

Design proposals for glazing systems incorporating sprinklers should be subject to risk assessment, which should include an assessment of all the elements of the glazing system, the level of protection afforded by the sprinklers, and the criticality of the element of glazing to the fire safety of the building. This assessment should include the sensitivity of glazing to thermal shock from water impingement under fire conditions, and the vulnerability of glazing sealants and glass retention methods. Fire-resistant glazing used in the construction should be of a type that is not vulnerable to water.

Where sprinklers are provided together with a glazed assembly, intended to work together as a combined fire-resisting wall system, then the following conditions should be observed.

- a) The whole assembly should be designed as an integrated sprinkler-glass system, which should be installed in accordance with the manufacturer's specific data sheet that applies for such a sprinkler-glazing arrangement. The water supply and other features of the sprinkler system design not specifically addressed by the manufacturer's data sheet should be in accordance with BS EN 12845.
- b) The sprinkler system should have a demonstrated capacity to deliver the required quantity of water throughout the full required period of fire resistance.
- c) Either:
 - 1) the glazed system should at least be classified for non-insulated fire-resistance performance, using a fire-resisting glass type that is not sensitive to water impingement failure under fire conditions; or
 - 2) if not classified for non-insulated fire-resistance performance, the sprinkler array, when activated, should be able to wet the entire glazed surface of the assembly throughout the full period of any potential developed fire exposure, without the risk of dry spots caused by transoms and mullions or other obstructions during occupation of the building.

NOTE Fire resistance to be met by elements of structure, doors, and other forms of construction is determined in accordance with the relevant part of BS 476 or European equivalent.

23 Active fire curtain/barrier assemblies

COMMENTARY ON CLAUSE 23

Active fire curtain/barrier assemblies can be horizontal, vertical or angled. For example, in certain end-use applications, these could be used in place of fire doors, non-loadbearing walls, non-loadbearing ceilings and glazed elements.

The type of active fire curtain/barrier assembly permitted in a fire-resisting construction depends on whether the barrier needs to afford the same protection as the remainder of the enclosure in which it is situated, or whether it is only necessary for the fire barrier to afford protection against the passage of flames, hot gases and smoke at ambient temperatures.

Where active fire curtain/barrier assemblies are used, they should be in accordance with BS 8524 and should:

- a) be deployed by an appropriate automatic fire detector;
- b) be capable of multi-stage deployment to initially act as a smoke barrier relevant to the risk, where deemed necessary;
- c) have emergency retract buttons relevant to the risk;

- d) have built in anti-obstruction detectors, full coverage of area to prevent furniture being positioned in the barrier's path;
NOTE These need to have timers set for a maximum of 10 min.
- e) have controls and associated wiring that is appropriate to the risk and type;
- f) have deployment speeds in ranging between 0.06 m/s and 0.15 m/s;
- g) achieve the same standard of fire resistance, integrity, insulation or radiation and smoke separation as the element of structure being replaced;
- h) have automatic monthly testing and logging;
- i) have monitoring of the battery condition;
- j) have display panels having visual and audible provision to:
 - 1) indicate any faults; and
 - 2) indicate if the batteries (for emergency retract) need replacing.

24 Openings

24.1 Fire doors

COMMENTARY ON 24.1

Fire doors have at least one of two functions:

- a) *to protect escape routes from the effects of fire so that occupants can reach a final exit;*
- b) *to protect occupants, fire-fighters and the contents and/or structure of a building by limiting the spread of fire.*

24.1.1 General

Doors in fire-separating elements are one of the most important features of a fire protection strategy, and it is important to select a fire door that is suitable for its intended purpose. They should normally be self-closing unless they give access to cupboards or service risers, in which case they should be kept locked.

NOTE The reliability of a fire door, especially in heavily-trafficked places, can be improved by hold-open devices that release the door automatically in response to a fire.

Fire doors should have a specified level of integrity but they do not usually need to be insulated, as there is no fire load immediately next to a door (it is normally part of a circulation route) for fire to spread by contact with the door surface. If fire doors are not insulated, however, there needs to be some limitation on the proportion of doorway openings in compartment walls and, with the exception of walls less than 5 m in length, no more than 25% of the length of a compartment wall should consist of door openings.

24.1.2 Installation

COMMENTARY ON 24.1.2

The failure of doors under fire conditions usually occurs at one of the following places:

- *at the gap between the door and the frame;*
- *at the meeting point between two door leaves in double door assemblies;*
- *at one or more of the points where building hardware is fixed (particularly at the hinges or lock positions);*

- *in the case of glazed doors, at the line of the junction between the glazed area and the rest of the door.*

Doors installed on site should conform, in dimensions and workmanship, to the manufacturer's specification for the appropriate fire resistance test report/assessment. Doors should be hung to ensure a good fit to the frame when closed, and the junction between door assembly and surrounding structure should be adequately sealed.

NOTE 1 Recommendations for the specification, installation and maintenance of hinged or pivoted pedestrian fire doors are given in BS 8214.

Security requirements should not override the need to provide adequate means of escape. All security locks and/or devices fitted to a dwelling entrance or alternative exit door should be operable from the inside by a single manual operation not requiring the use of a key.

Integrated elements such as locks, letter plates and security viewers should not reduce the fire resistance of the door.

NOTE 2 Advice on the selection of door furniture and the positioning and size of cut-out is available from the Association of Builders' Hardware Manufacturers' Code of practice for hardware essential to the optimum performance of fire-resisting timber doorsets [24].

Doors forming part of the means of escape from, and within, the building should:

- a) be fitted only with simple fastenings that can be operated from the escape side of the door without the use of a key;
- b) be hung clear of any change of floor level;
- c) be hung so that they do not reduce the effective width of any escape route across a landing;
- d) if opening into a corridor, be recessed to the full width of the door;
- e) where hung to swing both ways (double swing), or subdividing corridors, be provided with a minimum of a vision panel;

NOTE 3 For further information, see BS 8300.

- f) open to an angle not less than 90°.

24.1.3 Fire resistance

NOTE 1 Fire authorities and insurance companies might require a higher fire performance than that recommended in this British Standard.

NOTE 2 Guidance of performance appropriate to insurance requirements is given in the LPC design guide for the fire protection of buildings [25]. This addresses the use of uninsulated doors and criteria for longevity and robustness in normal usage.

In any dwelling, the minimum fire resistance should be FD 30 for a fire door forming part of the enclosure of any of the following:

- a) a protected escape route within a house;
- b) a protected entrance hall within a flat;
- c) a protected entrance hall and landing within a maisonette;
- d) a partition separating living and sleeping accommodation.

For other locations, the fire resistance of fire doors should be not less than the value given in Table 12 for the appropriate location. Unless otherwise recommended, the fire resistance should in all cases be not less than 30 min from either side, except in the case of doors to lift wells, where the fire resistance only needs to be from the landing side.

NOTE 3 In Table 12, where a fire door also needs to provide smoke control to resist leakage at ambient temperatures it has the suffix "S".

Table 12 Provisions for fire doors

Position of door		Minimum fire resistance of door in terms of integrity ^{A)}		
		When tested in accordance with BS 476-22	When tested in accordance with BS EN 1634-1	When tested in accordance with BS EN 81-58
1	In a compartment wall separating buildings	As for the wall in which door is fitted, but not less than 60 min	As for the wall in which the door is fitted, but not less than 60 min	—
2	In a compartment wall:			
a	if it separates a flat from a space in common use	FD 30S ^{B)}	E 30 S _a ^{B)}	—
b	enclosing a protected shaft forming a stairway situated wholly or partly above the adjoining ground	FD 30S ^{B)}	E 30 S _a ^{B)}	—
c	enclosing a protected shaft forming a stairway not described in 2b)	Half the period of fire resistance of the wall in which it is fitted but not less than 30 min and with suffix S ^{B)}	Half the period of fire resistance of the wall in which it is fitted but not less than 30 min minimum and with suffix S _a ^{B)}	—
d	enclosing a protected shaft forming a lift well or service shaft	Half the period of fire resistance of the wall in which it is fitted but not less than 30 min	Half the period of fire resistance of the wall in which it is fitted but not less than 30 min	Half the period of fire resistance of the wall in which it is fitted but not less than 30 min
e	not described in 2a), 2b), 2c) or 2d)	As for the wall it is fitted in, but with suffix S if the door is used for progressive horizontal evacuation	As for the wall it is fitted in, but add S _a ^{B)} if the door is used for progressive horizontal evacuation	—
3	In a compartment floor	As for the floor in which it is fitted	As for the floor in which it is fitted	—
4	Forming part of the enclosure of:			
a	a protected stairway (except where described in item 10)	FD 30S ^{B)}	E 30 S _a ^{B)}	—
b	the separation between upward and downward flights of a basement stair	FD 30S ^{B)}	E 30 S _a ^{B)}	—
c	lift well, which does not form a protected shaft in 2b), 2c) or 2d)	—	—	E30

Table 12 Provisions for fire doors

Position of door	Minimum fire resistance of door in terms of integrity ^{A)}		
	When tested in accordance with BS 476-22	When tested in accordance with BS EN 1634-1	When tested in accordance with BS EN 81-58
5 Forming part of the enclosures of:			
a a protected lobby approach (or protected corridor) to a stairway, except for a fire-fighting stair	FD 30S ^{B)}	E 30 S _a ^{B)}	—
b any other protected corridor, or	FD 20S ^{B)}	E 20 S _a ^{B)}	—
c a protected lobby approach to a lift shaft	FD 30S ^{B)}	E 30 S _a ^{B)}	—
6 Forming part of the enclosures of:			
a evacuation lifts or refuges, except for lift landing doors	FD 30S ^{B)}	E 30 S _a ^{B)}	—
b evacuation lifts, where the door is a lift landing door	—	—	E30
7 Affording access to an external escape route	FD 30	E 30	—
8 Subdividing:			
a corridors connecting alternative exits	FD 30S ^{B)}	E 30 S _a ^{B)}	—
b dead-end portions of corridors from the remainder of the corridor	FD 30S ^{B)}	E 30 S _a ^{B)}	—
9 Any door:			
a within a cavity barrier	FD 30	E 30	—
b forming part of the enclosure to a communal area in specialized housing	FD 30S ^{B)}	E 30 S _a ^{B)}	—
10 Any door:			
a forming part of the enclosure to a protected entrance hall or protected landing in a flat	FD 30	E 30	—
b within any other fire-resisting construction in dwelling accommodation not described elsewhere in this table	FD 30	E 30	—

NOTE 1 For fire-fighting shafts, see Clause 14, Clause 49 and Clause 50.

NOTE 2 The national classifications do not automatically equate with the equivalent classifications in the European column, therefore products cannot typically assume a European class unless they have been tested accordingly.

NOTE 3 For the separation between upward and downward flights of a basement stair (item 4 b), see Clause 30 and Clause 31.

^{A)} Fire doors are designated by reference to their recommended performance (in minutes) for integrity only, and whether they need to retard the passage of smoke at ambient temperature. The need to include insulation as part of the specification is dependent on the function of the door. For example, reference FD 60 is to a door that should achieve not less than 60 min integrity when tested in accordance with BS 476-22 or BS EN 1634-1.

^{B)} See 24.1.7.

Two doors in series of half the level of fire resistance of a compartment wall may be used instead of a single door, provided that neither of the two doors has a fire resistance of less than 30 min and each door is capable of closing the opening. In such a case, if the opening is provided as a means of escape, both doors should be self-closing. Neither should be a shutter, but one of them may be fitted with a self-closing device and be held open by a fusible link if the other door is capable of being easily opened by hand.

Where a fire resistance period in excess of 60 min is to be achieved by the use of two doors in series, the incorporation of materials sensitive to thermal shock, such as some types of glass, should be avoided unless test evidence is available to support the use of these materials.

24.1.4 Glazing in fire doors

Where glazed elements in fire-resisting enclosures and doors are able to meet the relevant performance only in terms of integrity (i.e. they are unable to meet the relevant performance in terms of insulation), the use of glass should be limited in accordance with Clause 22.

Insulation performance-rated glazing may be installed in an integrity performance fire-resistant door, but integrity glass should not be installed in a door requiring insulation.

24.1.5 Lift landing doors

Where lift landing doors need to be fire doors, they should achieve the appropriate level of fire resistance in terms of integrity (see Table 3 and Table 12) when tested in accordance with BS EN 81-58.

NOTE Lifts opening directly into flats are outside the scope of this standard.

24.1.6 Closure systems

24.1.6.1 Self-closing devices

Fire doors can only operate correctly if they are fully closed at the time of fire. As a result, all fire doors, except those leading to a cupboard or service duct (both of which are normally kept locked shut) and with the exception of lift landing doors, should be fitted with a self-closing device (other than rising-butt hinges) that should:

- a) be of a type that cannot readily be disconnected or immobilized and does not embody a mechanical hold-open facility unless it automatically releases the door in a fire situation (see 24.1.6.2); and
- b) override any latches fitted to the door, or in the absence of a suitable latch or other positive device for holding the door shut in its frame, be of a type that when tested in accordance with BS 476-22 or BS EN 1634-1 is shown to be able to hold the door closed in the frame for a sufficient period of time for the closing role to be taken over by a thermally activated sealing device (e.g. an intumescent seal), or throughout the full period of exposure if such seals are not incorporated; and
- c) for swing doors, conform to BS EN 1154.

Self-closing fire doors are more likely to be propped open, and thus rendered ineffective, by the occupants of a building if the doors are regarded as an impediment to access. Poorly specified self-closing devices can make fire doors virtually impassable to some people, e.g. wheelchair users and those with limited upper body strength. Door closer forces should be limited to the minimum necessary to close the door reliably and effectively.

If the force needed to open a door on a circulation route exceeds 30 N, or if an automatic self-closing device would be considered a hindrance to the occupants of the building, then hold-open devices in accordance with 24.1.6.2 should be used.

Self-closing devices need not be provided on fire doors within a dwelling, flat or maisonette, except between an attached or integral dwelling and on the door between a flat and communal areas.

NOTE 1 BS 8300 states that, for most disabled people to have independent access through single or double swing doors, the opening force, when measured at the leading edge of the door, should be not more than 30 N from 0° (the door in the closed position) to 30° open, and not more than 22.5 N from 30° to 60° of the opening cycle.

NOTE 2 The opening force can be checked using a plunger-type force measuring instrument. Where measurements cannot be taken at the leading edge, they may be taken at a point on the face of the door up to 60 mm from the leading edge, a position approximately in line vertically with the spindle of a lever handle or the centre line of a pull handle or push plate, in which case the opening force limits can be increased by approximately 2 N. The accuracy of force measuring instruments available on the market varies and there are inherent difficulties in measuring forces on site. It is recognized, therefore, that any measurements are subject to a degree of imprecision which could give rise to variations of between 2 N and 3 N.

24.1.6.2 Hold-open devices

Hold-open devices are used either to hold a fire door in the open position, against the action of a door closer, or to allow it to swing freely, automatically releasing the closing mechanism in a fire situation. If a hold-open device is to be used, it should be:

- a) a fusible link or heat detector (unless the door is fitted in an opening provided as a means of escape, or to protect a means of escape); or
- b) an automatic release mechanism actuated by an automatic fire detection and alarm system; or
- c) a delayed closing device with the delay adjusted not to exceed 25 s.

The automatic release mechanism should allow the door closing device to resume its self-closing function in the event of one or more of the following:

- 1) the detection of smoke by suitable automatic apparatus;
- 2) the detection of heat or smoke by any in-built sensing device;
- 3) failure of the power supply;
- 4) operation of the fire alarm system;
- 5) local manual operation;
- 6) if the facility is provided, a manual operation at a central control point.

NOTE 1 BS EN 1155 specifies requirements for separate hold-open devices and also for hold-open mechanisms incorporated in a door closer. Devices manufactured in accordance with BS EN 1155 can hold a swing door at a fixed position or can allow the door to swing freely. BS 5839-3 specifies requirements for certain automatic release mechanisms intended to hold open (or closed) fire protection equipment, such as fire doors, fire shutters, fire dampers, etc., which are outside the scope of BS EN 1155.

NOTE 2 BS 7273-4 gives recommendations for the design, installation, commissioning and maintenance of electrical control arrangements for actuation of mechanisms that unlock, release or open doors in the event of fire.

24.1.7 Smoke sealing of fire doors

A fire door that is needed to resist the passage of smoke at ambient temperature conditions, i.e. fire doors having the suffix S (see 24.1.3 and Table 12), should either:

- a) have a leakage rate not exceeding $3 \text{ m}^3/\text{h}/\text{m}$, when tested in accordance with BS 476-31.1 with the threshold taped and subjected to a pressure of 25 Pa; or
- b) meet the classification requirement of Sa when tested in accordance with BS EN 1634-3:2004.

When installed, the threshold gap should, where practicable, be sealed by a (flexible edge) seal either with a leakage rate not exceeding $3 \text{ m}^3/\text{h}/\text{m}$ at 25 Pa, or just contacting the floor, giving an even contact with the floor but not exhibiting significant increased frictional forces that could interfere with the closing action of the door. Where this is impracticable, the threshold gap should not exceed 3 mm at any point.

NOTE 1 When other methods of smoke control are provided in buildings, e.g. pressurization, the smoke control criteria for doors might not be applicable, depending on the design of the system, and in particular the air flow path(s).

NOTE 2 Smoke leakage control can be applied to non-fire-resisting doorsets.

24.1.8 Building hardware

Building hardware used on fire-resisting doors can significantly affect their performance in the event of a fire and this should be taken into account when determining which hardware to use.

NOTE General guidance is given in BS 8214. DHF publication CP 102 [26] gives guidance on fire-resisting metal doorsets.

Unless shown to be satisfactory when tested in accordance with BS 476-22 or BS EN 1634-1, no part of a hinge on which any fire door is hung, and which provides the means of support at the hanging edge, should be made either of combustible material or of non-combustible material having a melting point less than 800 °C.

All items of hardware for use on fire doors should be suitable for the type of door to which they are fitted.

24.1.9 Fire door signage

All fire doors other than lift entrance doors should be marked with the appropriate fire safety sign conforming to BS ISO 3864-1 according to whether the door is:

- a) to be kept closed when not in use;
- b) to be kept locked when not in use; or
- c) held open by an automatic release mechanism.

Fire doors to cupboards and to service ducts should be marked on the outside. All other fire doors should be marked on both sides.

NOTE Lift entrance doors do not need to be marked.

24.2 Shutter assemblies

Shutter assemblies across a means of escape should be released only by a heat sensor, such as a fusible link or electric heat detector, in the immediate vicinity of the door. Closure of shutters in such locations should not be initiated by smoke detectors or a fire alarm system, unless the shutter is also intended to act as a smoke curtain.

Shutter assemblies should achieve the appropriate level of fire resistance in terms of integrity (see Table 3 and Table 12) when tested in accordance with BS 476-22 or BS EN 1634-1.

24.3 Access panels

Access panels should be of a construction that has at least the same fire resistance as the element they fit into. This should be achieved by having:

- a) the recommended fire resistance from both sides; or
- b) an automatic heat activated sealing device, which in the event of fire will close the opening to maintain the fire resistance recommended for the compartment wall or floor.

24.4 Fire-stopping

COMMENTARY ON 24.4

When a building service passes through a compartment wall or floor there can be an imperfection of fit, which results in gaps in the walls between compartments. This presents a risk of allowing smoke and flame to breach a compartment wall via these gaps. It is therefore necessary to fill these gaps with a material that will restrict the passage of smoke and flame. Various materials can be used, but certain materials are more suited to certain applications.

24.4.1 Applications

Joints between elements that serve as a barrier to the passage of fire should be fire-stopped. All openings for pipes, ducts, conduits or cables to pass through any part of an element that serves as a barrier to the passage of fire should be:

- a) kept as few in number as possible;
- b) kept as small as practicable; and
- c) fire-stopped (which in the case of a flue or duct, should allow thermal movement).

24.4.2 Products and materials for fire-stopping

The selection of products and materials used for fire-stopping should take account of the size and nature of the gap and any anticipated differential movement.

Proprietary fire-stopping and sealing systems (including those designed for service penetrations) are available and may be used provided that they achieve the appropriate level of fire resistance (see Table 3) when tested in accordance with BS 476-22 or BS EN 1634-1.

In the case where minimum differential movement is anticipated and where the gap does not exceed 25 mm, the following fire-stopping materials may be used without specific test evidence:

- a) cement mortar;
- b) gypsum-based plaster;
- c) cement or gypsum-based vermiculite/perlite mixes.

To maintain the physical integrity of fire-stopping, it should be reinforced with (or supported by) non-combustible materials, or materials of limited combustibility, in the following circumstances:

- 1) in all cases where the gap between elements that need to be fire-stopped is greater than 100 mm; and
- 2) in any other case where non-rigid or flexible materials are used (unless substantiated by fire test evidence).

25 Floors and ramps on escape routes

The floors of an escape route, including the treads of any stair and the floor of any landing, should have non-slippery, even surfaces.

Ramps should have a gradient of no more than 1 in 12.

26 Design and construction of common stairs

Common stairs should:

- a) be designed and constructed in accordance with BS 5395-1;

NOTE 1 Stairs conforming to the Building Regulations 2010, Approved Document K [27] are also acceptable.

- b) meet the recommendations for width given in Clause 28;
- c) have flights and landings constructed of materials of limited combustibility, with the exception of:
 - 1) stairs in multi-stair buildings with no floor at 18 m or more above ground level; or
 - 2) two or three storey buildings, or parts of a building, served by a single stair;
- d) be formed of straight flights in all buildings of more than three storeys.

Ladders should not form part of a means of escape route from any dwelling. Ladders designed and constructed in accordance with BS EN ISO 14122-4 may form part of a means of escape route from areas of a building where access is limited to occasional purposes of maintenance and repair.

NOTE 2 Guidance on the fire assessment of timber stair construction is given in CLG publication Fire performance of escape stairs: BD 2569 [28] and Building Control Alliance Guidance Note 19 [29].

Section 5: Stairs and final exits

27 Number and siting of common stairs

COMMENTARY ON CLAUSE 27

In buildings or parts of buildings occupied for non-residential purposes a single common stair would be considered acceptable only in very limited circumstances. However, in buildings comprising flats and/or maisonettes, because of the degree of compartmentation provided and the special provisions made for controlling the spread of smoke within common horizontal escape routes, whether or not a single common stair is acceptable depends entirely on any limitations imposed in respect of travel distances or, for balcony or deck approach dwellings, fire-fighting needs.

A minimum of one common stair should be available from each storey providing access to dwellings.

Where necessary, additional common stairs should be provided to enable dwellings to meet travel distance recommendations or, for balcony or deck approach dwellings, fire-fighting needs (see Figure 5). Additional common stairs should be sited such that they provide effective alternative directions of travel from any dwelling served by those stairs other than accepted dead ends [see Figure 7b)].

Where two or more common stairs are provided they should be located such that they are situated remotely from each other. Where a common corridor connects two or more storey exits, measures should be provided to prevent both stairs from being affected by the smoke from a single fire. Such measures may include subdivision by a self-closing fire door with, if necessary, an associated fire screen. The door should be positioned such that smoke is not likely to affect access to more than one storey exit.

28 Width of common stairs

The unobstructed width (measured between the walls and/or balustrades) of each common stair should be not less than 750 mm; a common stair which is a fire-fighting stair should have an unobstructed width (measured between the walls and/or balustrades) of 1.1 m. The width should be kept clear for a vertical distance of 2.0 m.

NOTE Handrails and strings that do not intrude more than 100 mm into these widths may be discounted when calculating the common stair width.

29 Enclosure of common stairs

In buildings exceeding 18 m in height, one or more common stairs should be designed as fire-fighting stairs.

NOTE 1 See 50.2 and 50.3 for further information on fire-fighting stairs.

The following recommendations should be met for common stairs that are not fire-fighting stairs.

- a) No store room should open directly into a common stair.

NOTE 2 Recommendations for engineering services such as gas, electricity and refuse disposal are given in Section 7.

- b) If a common stair projects beyond, is recessed from, or forms an internal angle of, the external enclosures to a building:
- 1) the distance between any opening in the external enclosure to the building and any opening in the enclosure to the stair should be not less than 1.8 m (see Figure 31); and
 - 2) the enclosures within that distance [see b)1)] and up to 9 m vertically below should be of fire-resisting construction that may have fixed fire-resisting glazed areas.
- c) Where two common stairs are adjoining, they should be separated by imperforate construction.
- NOTE 3 No openings, doors, etc. are permitted in the separating elements common to both stairway enclosures.*
- d) If any storey or part of a storey is required to have more than one escape route, common stairs should be sited so that access to alternative common stairs is possible from any point on that storey without passing through any other such stairway.
- e) If a common stair forms part of the only escape route from a dwelling it should not be connected to any ancillary accommodation on the same storey as that dwelling, unless it is in accordance with 7.5 and 30.2.

Figure 31 Protected routes forming an internal angle

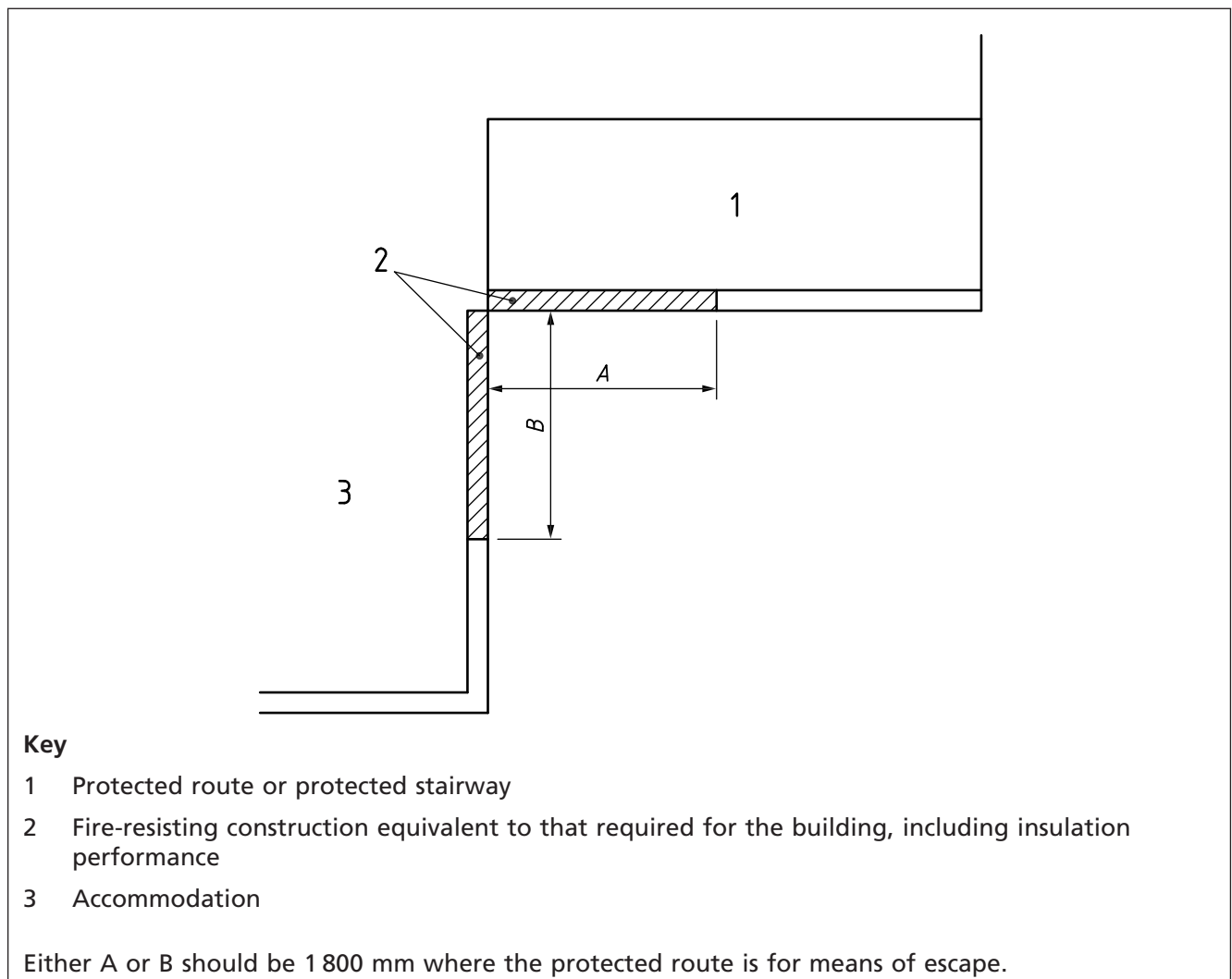

30 Basement stairs

30.1 Multiple stair buildings

Where there is more than one common stair from an upper storey or part thereof, at least one such stair serving the upper storeys (or parts thereof) should terminate at ground level; any other stair may connect with the basement storey(s), provided that it is separated from each basement level by a protected lobby.

30.2 Single stair buildings

If a stair forms part of the only escape route from an upper storey or part thereof, the stair should not continue down to the basement except as follows.

In small buildings where the top floor is no more than 11 m above ground level or where there are no more than three storeys above the ground storey, a single stair may connect with the basement provided that the following recommendations are met.

- The basement and upper storeys should be separated within the staircase at ground floor level by fire-resisting construction including an FD 30S self-closing door (see Figure 32).
- A fire-resisting lobby should be provided at basement level between the accommodation and the staircase and any associated lift well.
- The lobby should be provided with a vent in accordance with Table 13.

Figure 32 Staircase separating basement and upper storeys in single stair residential buildings

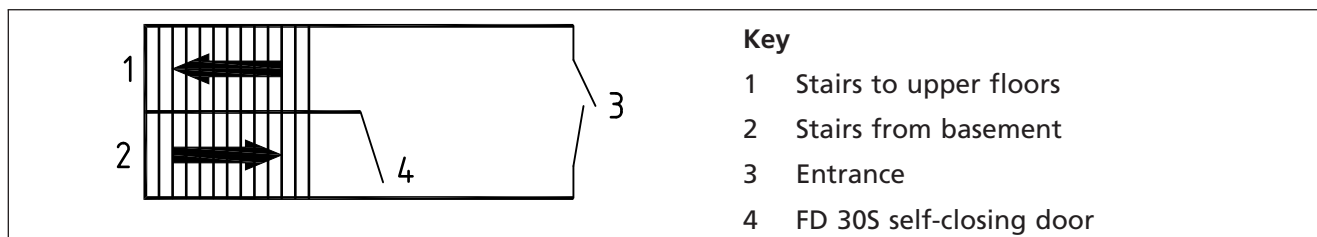

Table 13 Lobby ventilation

Item	Accommodation area ^{A) B)}	Ventilation to lobby
1	Flats	In accordance with Clause 14
2	Communal lounges and common amenity areas	1 m ² permanent ventilation; or 0.4 m ² permanent ventilation with provision of automatic sprinkler protection in accordance with BS EN 12845 throughout the basement
3	Transformer, switchgear and battery rooms for low voltage or extra low voltage equipment	
4	Engineering service installation rooms, excluding those covered by item 2 and items 6 to 8 inclusive	
5	Refuse chutes and refuse storage areas	
6	Other storage areas	
7	Installation rooms for engineering services housing fixed internal combustion engines	
8	Boiler rooms and fuel storage spaces	1 m ² automatic opening vent
9	Transformer and switchgear for equipment above low voltage	
10	Car park areas	

^{A)} Places of special fire hazard should be provided with separate smoke outlets in accordance with Clause 14.

^{B)} Car park areas should be provided with a smoke control system in accordance with Clause 14.

31 Stairs within mixed-use developments

A mixed-use development is one that contains one or more dwelling(s) and at least one non-residential occupancy. Any stair serving a dwelling within a mixed-use development should not communicate with any other occupancy, unless in accordance with a) or b).

Mixed-use developments should meet the following recommendations.

- a) In buildings having not more than three storeys above ground or access level (small buildings), common stairs that serve both dwellings and other occupancies should be separated from each occupancy by protected lobbies at all levels.
- b) In buildings having more than three storeys above ground or access level:
 - 1) all stairs serving dwellings, which are not ancillary to the main use of the building, should not communicate with any other occupancy in that building;
 - 2) any stair serving a dwelling, which is ancillary to the main use of the building, may communicate with any other occupancy only if security measures do not prevent escape and:
 - i) the stair is separated from any lower storeys by protected lobbies; and
 - ii) an independent alternative escape route is provided from the dwelling; and
 - iii) where the main building is fitted with an automatic fire detection and alarm system (see Clause 10), this system also covers the dwelling.

32 Access lobbies and corridors to protected stairways

Access lobbies and corridors to protected stairways should meet the following recommendations.

- a) If a stair in a mixed-use building, having not more than three storeys above ground or access level, serves both dwellings and other non-residential occupancies, then a protected lobby should be provided between each occupancy and the stairway at all levels.
- b) If a stair provides access to ancillary accommodation, there should be a ventilated protected lobby or ventilated protected corridor at that level.
- c) If a stair provides access to an enclosed car park, there should be a ventilated protected lobby at every car park access level.
- d) If a stair serves an area of higher fire risk, there should be a ventilated protected lobby or ventilated protected corridor at that level.
- e) If a stair connects the ground or upper storeys with a basement storey(s) or serves only basement storeys, there should be a protected lobby or protected corridor at every basement level.
- f) In a small single-stair building, any protected lobby or protected corridor separating ancillary accommodation from the stair should be ventilated (see Clause 14).

NOTE For ventilated lobbies, refer to Table 13.

33 External stairs

External escape stairs, whilst not desirable, may, in exceptional circumstances, be provided for small buildings (see 7.5), or from storeys near to ground level, or from a roof or podium with its own escape route.

The following recommendations should be met for external stairs.

- a) External stairs should not form part of an escape route except in the case of:
 - 1) flats or maisonettes having an exit to a storey not more than 6 m above ground level;
 - 2) flats or maisonettes having an exit to a storey not more than 6 m above a roof or podium which is itself served by an independent protected escape route.
- b) Any wall or portion (unless higher than 1.1 m above the top floor level of a stair that is not a basement stair) within 1.8 m of, or within 9 m vertically below, any external escape stair should be of fire-resisting construction. This fire-resisting construction may have fixed fire-resisting glazed areas, and the doors to the stair (other than the door at the top floor level of a stair serving storeys above ground level) should be fire-resisting and self-closing (see Figure 33).
- c) Where the escape route from the stair is in one direction only, any ventilation outlets or extract systems and any doors or windows that are not fire-resisting should not be sited within 3 m of the escape route.

Figure 33 Fire resistance of areas adjacent to external stairs

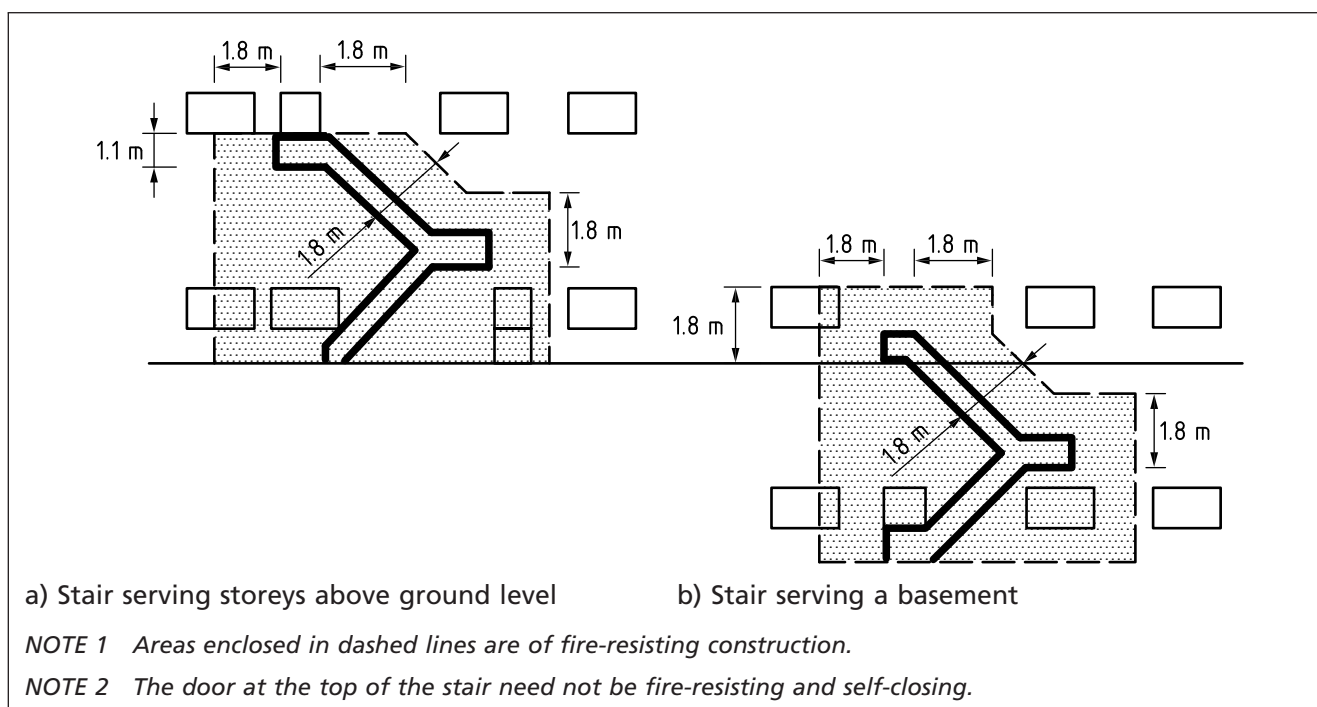

34 Discharge from common stairs and final exits

Discharge from common stairs and final exits should meet the following recommendations.

- a) Protected stairways should discharge either:
 - 1) directly to a final exit; or
 - 2) into a protected corridor leading to a final exit which is itself lobbied from any accommodation.

NOTE 1 Figure 34 shows examples of a final exit from a stairway with lobby protection accessed from a flat with a protected entrance hall.

NOTE 2 It is important that any protected corridor leading to a final exit has the same standard of fire-resisting enclosure and lobby protection as the stairway it serves and that it is not the common access corridor serving the dwellings at the exit level.

- b) An arrangement in which two stairs terminate in the same enclosure at final exit level should not be employed, because an outbreak of fire leading to penetration of the enclosure at that level would render both stairs simultaneously unusable.
- c) Where the exit passageways from two common stairs adjoin they should be separated by imperforate construction, i.e. there should be no openings, doors, etc. in the separating element common to both passageways.
- d) Any final exit should be immediately apparent to any person using a common stair that serves storeys both above and below the point of final exit.

NOTE 3 A final exit can be made immediately apparent through the use of signage.

- e) Final exits should discharge directly to a street, passageway, walkway or open space that allows for the rapid dispersal of persons away from the vicinity of the building.
- f) Final exits should have a level threshold and preferably lead to level ground. Where there is no level ground, a suitable ramp or a step should be provided. Where a step is provided there should be a suitable and apparent landing.
- g) Final exits should be sited such that they are clear of any risk from fire or smoke. If a protected route projects beyond, is recessed from, or forms an internal angle of, the external enclosures to a building, the distance between any opening in the external enclosure to the building and any opening in the enclosure to the stairway should be not less than 1.8 m (see Figure 31).
- h) Transformer chambers, boiler rooms and refuse storage rooms and similar risk areas should not have any openings, e.g. doors that open onto escape routes, which could impede escape from residential accommodation.

Where a tower block rises above a podium, it is preferable that the common stair(s) forming part of the escape route from the tower descend through the podium to ground level; any fire-fighting stair should certainly do so. Where other stairs cannot be so arranged and occupants are required to use the stairs of the podium, there should be adequate protection of the escape route connecting the two stairs to safeguard the occupants of the building until street level is reached. Similarly, any part of the escape route that leads (for example) across a concourse, a pedestrian walkway or roof should be clearly defined and protected.

Figure 34 Lobby protection to final exit from stairway

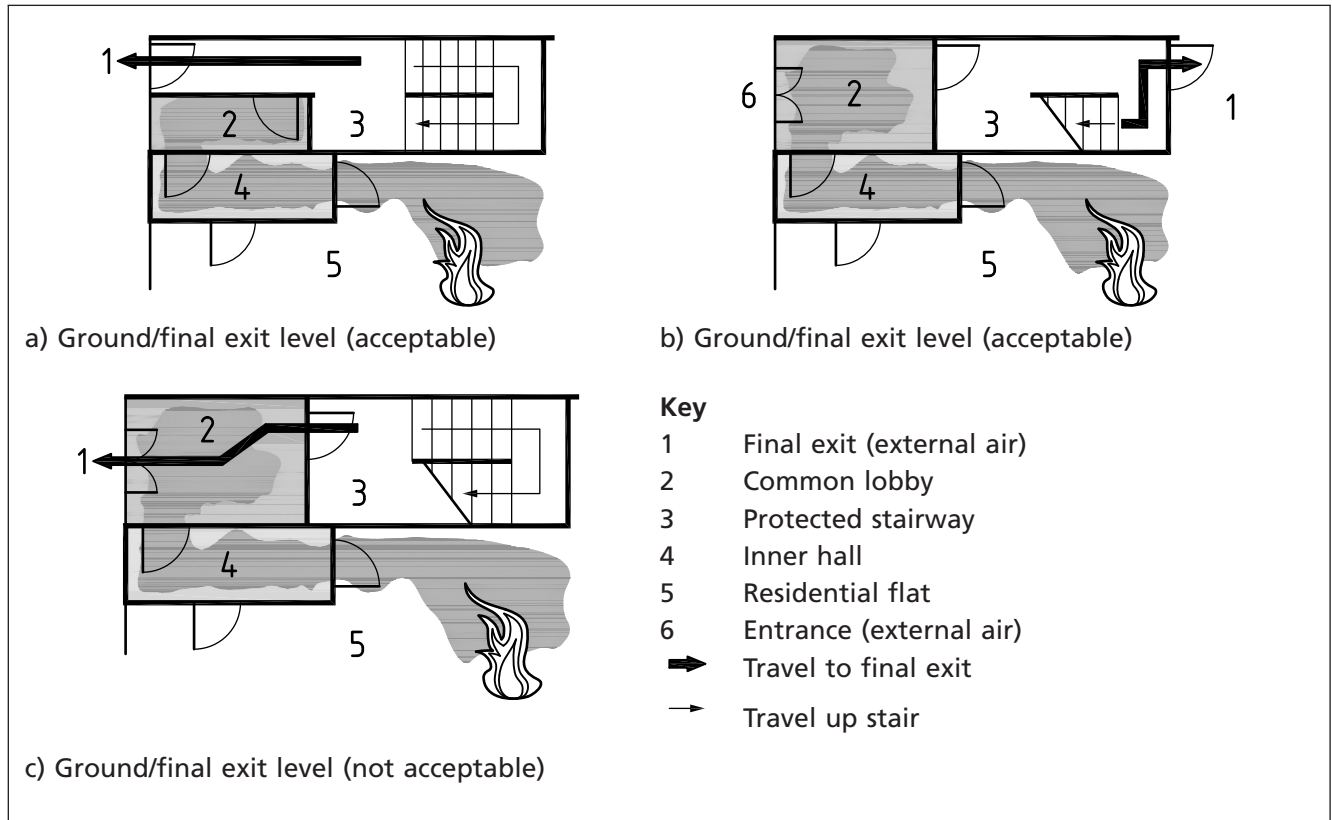

Section 6: Mechanical systems for ducted heating, ventilation and air conditioning (HVAC)

35 HVAC systems within individual dwellings

Ducted HVAC systems should be arranged such that fire and smoke is not transferred from the room of fire origin in a manner that could inhibit the safe use of protected internal means of escape routes or allow the undue spread of fire.

Any house, flat, maisonette or other residential unit with a floor over 4.5 m above ground level or any basement should meet the following recommendations.

- a) Transfer grilles should not be fitted in any wall, ceiling, floor or door enclosing a protected internal hallway or stair enclosure.
- b) Where practicable, ducts should be routed such that they do not pass through protected internal hallways or stair enclosures.
- c) Where the duct does pass through a protected internal hallway or stair enclosure, then:
 - 1) the duct should be provided with ES rated fire and smoke dampers conforming to BS EN 1366-2 where penetrating the fire-resisting enclosure (such dampers should be accessible for maintenance); or
 - 2) the duct should be of fire-resisting construction achieving 30 min integrity when tested from the inside (see Section 4); or
 - 3) the ceiling zone containing the duct should be bounded by the protected enclosure and provided with an imperforate ceiling construction achieving 30 min fire resistance integrity and insulation when tested from above (see Section 4), and have an upper surface of Class 1 surface spread of flame when tested in accordance with BS 476-7 or the European equivalent.
- d) Where an HVAC system re-circulates air and serves the protected internal hallway or stairway and other rooms, smoke detectors should be provided within the ductwork that switches the mode to shut down upon detection.
- e) HVAC ducted systems that link between dwellings or serve common areas should be in accordance with Clause 36.

36 HVAC systems serving the whole building or interconnecting dwellings and other residential units

Mechanical HVAC systems serving the whole building should be designed to prevent the spread of fire and smoke from the room of fire origin throughout the building. In particular, measures should be taken to ensure that air movement in the system prevents incursion of fire and combustion products into protected escape routes and does not allow fire compartmentation to be breached.

HVAC systems should be compatible with smoke control systems installed in the building (whether natural, mechanical exhaust or pressurization) when operating under fire conditions.

Measures to aid fire-fighting control should be incorporated, including the following.

- a) Ventilation systems serving protected escape routes should not serve other areas and the normal airflow pattern should be directed away from the escape route.
- b) Separate ventilations systems that do not allow for the re-circulation of air within them should also be provided for:
 - 1) each protected stairway;
 - 2) plant areas;
 - 3) car parks;
 - 4) non-domestic kitchens; and
 - 5) residential parts of mixed-use buildings.
- c) Ducts passing through the enclosure of a protected escape route should meet the relevant fire-resistance recommendations (protection using fire-resisting enclosures, or protection using fire-resisting ductwork) given in BS 9999.
- d) Where a ductwork system serves more than one part of a compartmented or fire-separated escape route, smoke detector operated fire dampers should be provided where the ductwork enters each fire-separated or smoke-separated section of the escape route. Where a fire damper is used to protect an escape route, it should be tested in accordance with BS EN 1366-2 and an ES classification equal to or greater than 60 min in accordance with BS EN 13501-3.

NOTE 1 See also 21.2.

- e) Ducts passing through compartment walls and floors and other fire-separating elements should maintain the fire integrity using one of the following methods given in BS 9999:
 - 1) using fire dampers;
 - 2) using fire-resisting enclosures; or
 - 3) using fire-resisting ductwork.
- f) Where ductwork serves more than one flat or maisonette, smoke detector operated fire and smoke dampers should be provided where the ductwork enters each dwelling. Such dampers should be tested in accordance with BS EN 1366-2 and an ES classification equal to or greater than 60 min in accordance with BS EN 13501-3.
- g) The fire resistance of ducts and dampers should be equal to the fire resistance required for the building element being penetrated. All ducts should be fire-stopped where they penetrate compartments and fire-resisting enclosure of escape routes.
- h) Systems which re-circulate air should be fitted with smoke detectors in the extract ductwork before the point of separation of the re-circulated air and the air to be discharged and before any filters or other air cleaning equipment. Detection should cause the system to immediately shut down or switch to extract the air to an external location.

NOTE 2 Further detail is given in BS 9999.

- i) Systems should be provided with overriding fire-fighting controls in accordance with BS 9999.

- j) Air transfer grilles should not be positioned in enclosures to protected stairways, protected lobbies, protected corridors, fire-fighting stairways and lobbies, protected shafts and compartment walls or floors.

NOTE 3 Further information on air transfer grilles is given in BS 9999.

- k) Exhaust outlets should be positioned such that they:
- 1) do not discharge products of combustion close to final exits or other parts of escape routes;
 - 2) are not close to any combustibile or otherwise vulnerable element of the building construction;
 - 3) do not enable re-entry of exhaust products back into the building or other ductwork.
- l) Ducts should be designed and constructed in accordance with BS 8313.
- m) Where pressurization or other smoke control systems are installed within a building, any ventilation and air conditioning system should be compatible with its operation under fire conditions.
- n) Where plant areas are within the building, they should be treated as separate fire compartments in order to isolate any fire source.

NOTE 4 Further guidance is given in BS 9999, ASFP Blue Book [30], ASFP Grey Book [31] and BS 5839-1:2013.

Section 7: Ancillary accommodation to flats and maisonettes

37 General recommendations for ancillary accommodation

COMMENTARY ON CLAUSE 37

Ancillary accommodation covers all those parts of buildings containing flats or maisonettes that are ancillary to the dwellings. It includes engineering services and such accommodation as common amenity areas, refuse rooms and covered car parks.

Engineering services include the following:

- a) *gas services;*
- b) *electrical services and wiring;*
- c) *lighting;*
- d) *lift machine rooms/machinery spaces;*
- e) *communal heating, ventilation and air conditioning systems;*
- f) *refuse storage, disposal and incineration;*
- g) *car parks.*

Ancillary accommodation generally presents a greater fire hazard than the dwellings themselves because the accommodation might only be visited occasionally and is thus not under regular surveillance.

Ancillary accommodation should meet the following recommendations.

- a) Ancillary accommodation should have escape routes of such number and be situated such that the travel distance from any point does not exceed the limitations given in Table 14.
- b) Ancillary accommodation should not connect with any part of the only escape route from one or more dwelling(s) on the same storey as the ancillary accommodation unless it meets the recommendations given in 7.5 and 30.2.
- c) In multi-stair buildings:
 - 1) ancillary accommodation should be separated from any stair by a protected lobby or protected corridor at the storey in which the accommodation is situated;
 - 2) ancillary accommodation should be separated from any common corridors by a protected lobby where the escape route is in a single direction.
- d) Ancillary accommodation should be separated from other parts of the building in accordance with Table 15 and, where necessary, have ventilated lobbies in accordance with Clause 13 and 14.1.6.
- e) Glazed areas separating escape routes from ancillary accommodation should be in accordance with Clause 22 and Clause 29.
- f) Emergency escape lighting should be provided in accordance with 44.2.
- g) All ancillary accommodation, with the exception of communal lounges, common amenity areas and transformer, switchgear and battery rooms for low voltage or extra low voltage equipment, should be treated as places of special fire hazard (see Clause 38).

Table 14 Maximum travel distances in areas of ancillary accommodation

Ancillary accommodation	Maximum part of travel distance within the room or area		Maximum travel distance to the nearest storey exit	
	Escape in one direction only	Escape in more than one direction, in directions 45° or more apart	Escape in one direction only	Escape in more than one direction, in directions 45° or more apart
	m	m	m	m
1. Engineering services installation rooms				
2. Boiler rooms	9	18	18	45 ^{A)}
3. Fuel storage areas				
4. Transformer, battery and switchgear rooms				
5. Communal lounges and common amenity areas	18	45 ^{A)}	18	45 ^{A)}
6. Covered car parks	18	45 ^{A)}	18	45 ^{A)}

^{A)} This may include up to 18 m with escape in one direction only.

Table 15 Structural fire protection of areas of ancillary accommodation

Ancillary accommodation	Structural fire protection
	Separation of area of ancillary accommodation from other parts of the building by:
1. Communal lounges	
2. Transformer, switchgear and battery rooms for low voltage or extra low voltage equipment	Robust construction having a minimum standard of fire resistance of 30 min ^{A)}
3. Engineering services installation rooms other than those covered by items 2 and 6 to 8 inclusive	
4. Refuse chutes and refuse storage areas	Robust construction having a minimum standard of fire resistance of 60 min ^{A)}
5. Covered car parks within or adjoining the building and not greater than 450 m ² in area	
6. Engineering services installation rooms, housing fixed internal combustion engines	
7. Boiler rooms and fuel storage spaces	Robust construction having a minimum standard of fire resistance equivalent to that required for the elements of construction and in no case less than 60 min ^{A)}
8. Transformer and switchgear rooms for equipment above low voltage	
9. Covered car parks within or adjoining the building and greater than 450 m ² in area	

^{A)} Any openings in the required construction should be protected by doors having a similar standard of fire resistance and capable of resisting the passage of smoke at ambient temperature.

38 Places of special fire hazard

COMMENTARY ON CLAUSE 38

Places of special fire hazard include oil-filled transformer and switch gear rooms, boiler rooms, storage spaces for fuel or other highly flammable substances and rooms housing a fixed internal combustion engine. Places of special fire hazard might need to have smoke or heat detectors fitted to give early warning of fire and sprinklers fitted in accordance with BS EN 12845 to control the fire.

Places of special fire hazard should be enclosed with fire-resisting construction in accordance with **16.2.1** (Table 3). Travel distances in places of special fire hazard should be limited to 9 m in a single direction or 18 m where escape is available in more than one direction.

NOTE Additional risk protection measures, such as increased fire resistance, might be needed to separate a flat from any storage area where fuels such as petrol and liquefied petroleum gas (LPG) are present.

Separate smoke outlets should be provided from places of special fire hazard located below ground level (see **14.2.1.3.2**).

Elements of construction enclosing places of special fire hazard should be in accordance with **16.2.1** (Table 3).

Where a common stair forms part of the only escape route from a flat, unless it is designated as a small single-stair building in accordance with **7.5**, it should not also serve any covered car park, boiler room, fuel storage space or other ancillary accommodation of similar fire risk.

Refuse chutes and refuse storage areas (see Clause **47**) should be separated from other parts of the building by fire-resisting construction in accordance with **16.2.1** (Table 3). They should not be located in protected stairways or protected lobbies.

39 Installation of engineering services

COMMENTARY ON CLAUSE 39

Some engineering services are known potential sources of fire. The importance of correct installation in the first place is emphasized, because lighting, heating and ventilation systems are often concealed above suspended ceilings and within service ducts.

Control gear is also often located behind ceiling and wall panels. Installation faults that might lead to fire are particularly dangerous because the fire is likely to remain undiscovered for some time if it is concealed.

The equipment associated with engineering services and control gear should be installed and maintained in accordance with the relevant codes of practice.

40 Engineering service installation rooms

COMMENTARY ON CLAUSE 40

Engineering service installation rooms include electrical switchgear rooms, boiler rooms, fuel storage spaces, mechanical ventilation and air conditioning plant rooms, lift motor rooms, rooms housing fixed internal combustion engines and battery charging rooms.

Service installation rooms should be sited such that escape from other exits is not prejudiced by any risk that they could pose.

Service installation rooms in which flammable liquids are used or stored should have imperforate sills to doorways, and any necessary drainage should be provided with interceptors.

Service installation rooms should, where necessary for the safe operation of the equipment and to avoid undue build-up of heat, be ventilated (either directly or indirectly) to the outside air. The provision of such ventilation should not impair any fire resistance requirements for the structure.

NOTE This ventilation may be combined with the provisions for smoke ventilation (see Clause 14).

Service installation rooms adjoining a building (including those on top of a flat roof) should be separated from the building in accordance with Table 12 and Table 15.

41 Gas services, installation and service pipes

All gas services and installation and service pipes should be installed such that the fire resistance of the building is unimpaired.

Installation and service pipes should not be run through escape routes.

NOTE 1 Attention is drawn to the Gas Safety (Installation and Use) Regulations 1998 [32], which cover the installation of gas fittings, including installation pipework, meters and appliances.

NOTE 2 Further guidance is also given in the following publications:

- *gas services: Institution of Gas Engineers and Managers' Publication IGE/ID/4 [33];*
- *low pressure installation pipes: BS 6891.*

42 Electrical services

42.1 Electrical service installations

Electrical services should be installed and maintained in accordance with BS 7671.

Methods of cable support should be non-combustible and such that circuit integrity is not reduced below that afforded by the cable used, and should be able to withstand a similar temperature and duration to that of the cable, while maintaining adequate support.

NOTE 1 In effect, this recommendation precludes the use of plastic cable clips, cable ties or trunking, where these products are the means of cable support.

NOTE 2 Experience has shown that collapse of cables, supported only by plastic cable trunking, can create a serious hazard for fire-fighters, who could become entangled in the cables.

42.2 Transformer, battery and switchgear rooms

A transformer, battery or switchgear room, unless situated on the roof or in a separate enclosure, should be sited adjacent to an external wall and entered only from the open air.

A transformer, battery or switchgear room should have adequate provision for ventilation.

42.3 Fire-fighter's emergency switches for discharge lighting installations

Discharge lighting installations can operate at voltages that are a hazard to fire-fighters. An exterior discharge lighting installation, or an interior discharge lighting installation, operating unattended or operating at a voltage exceeding low voltage, should be controlled by a fire-fighter's emergency switch. The fire and rescue authority should be consulted for advice regarding fire-fighter's emergency switches.

NOTE BS 7671 specifies requirements for the installation and situation of fire-fighter's emergency switches.

43 Gas and electricity meters

COMMENTARY ON CLAUSE 43

A gas or electricity meter can be a fire risk to a building and it is essential that such meters are properly and safely located and installed.

The location of meters should be agreed with the supply authority at the planning stage.

Gas meters and associated equipment should be installed in accordance with the relevant part(s) of BS 6400. The distance between electricity meters and gas meters not placed in meter boxes should be in accordance with BS 6400 (all parts). Wherever practicable, gas meters should not be installed in corridors in single-stair buildings or in dead-end corridors.

NOTE 1 Attention is drawn to the requirements for installation and connection set out in the Pipelines Safety Regulations 1996 [34] and the Gas Safety (Installation and Use) Regulations 1998 [32].

NOTE 2 Guidance on suitable gas installations in blocks of flats is given in IGENIG15 [35].

Electricity meters and associated equipment should be installed in accordance with BS 7671.

Where meter boxes are required, gas meters and electricity meters should be housed in separate boxes, each large enough only for the meter and associated equipment.

Wherever practicable, gas and electricity meters should not be located in the entrance hall of a dwelling, but if a meter is so positioned, it should be contained within a suitably constructed cupboard that is large enough to contain only the meter(s).

A meter should not be installed on or under a stairway, or in any other part of a building that has a maximum of one floor above the ground floor, for which the stairway, or that other part of the building, provides the only means of escape in the event of a fire, unless:

- a) the meter is:
 - 1) of fire-resisting construction; or
 - 2) housed in a protected compartment; or

NOTE 3 A protected compartment refers to an enclosure of fire-resisting construction fitted with a fire door that is kept locked shut. Further details are given in the Gas Safety (Installation and Use) Regulations 1998 [32].

- b) the pipe immediately upstream of the meter, or a governor (where a governor is adjacent to the meter), incorporates a device to automatically cut off the flow of gas when the temperature of the device exceeds 95 °C.

A meter should not be installed on or under a stairway, or in any other part of a building having two or more floors above the ground floor, where the stairway, or that other part of the building, provides the only means of escape in case of fire, unless the meter replaces an existing meter and is in accordance with either a) or b) above.

In single-stair buildings, an electric meter should not be installed within a common escape route unless it is enclosed within a secure cupboard (allowing access only to the electricity supply company) which is separated from the common escape route by construction having a fire resistance of 30 min.

To facilitate external meter reading and attendance, the meters in flats and maisonettes may be located to be accessible or visible from a common circulation space (not a common stair) through robust doors provided with locks. Glazed viewing panels large enough to expose dials and meter numbers may be provided, where desired. Where meters are inset into a fire-resisting wall or partition, they should be separated at the back and sides from the dwelling by non-combustible construction having the same fire resistance as that recommended for the element in which they are placed.

44 Lighting

44.1 Types of luminaire

Incandescent filament lamps and high pressure discharge lamps operate at elevated temperatures, and where these are used they should not be close to or fixed to materials that are readily ignited. Minimum separation distances should be applied in accordance with BS 7671. Care should be taken in the selection of plastics materials or finishes and preference should be given to those with superior flame retardant qualities.

44.2 Lighting of common escape routes in buildings containing flats or maisonettes

Provision should be made for lighting along common escape routes (except in two-storey blocks of flats) so that occupants and visitors to the building can see their way to safety, even in the event that the main electricity supply fails. The lighting should be such that directional or warning signs associated with common escape routes, changes in floor level, the location of fire alarm call points and fire-fighting equipment are also visible. Where an emergency escape lighting system is provided, it should meet the appropriate recommendations in BS 5266-1.

NOTE The essential feature of emergency escape lighting is that it is designed to illuminate when part or all of the normal lighting has failed. There are various types of emergency escape lighting, e.g. lighting that is continuously alight; lighting that is not illuminated until the mains fail, but lights automatically; single independent luminaires or central battery or generator systems.

Emergency escape lighting should also be provided within:

- a) ancillary accommodation normally accessible to the occupants;
- b) common stairs;
- c) all common escape routes in specialized housing;
- d) common escape routes across a flat roof;
- e) windowless accommodation within live-work units.

Where an emergency escape lighting system is not provided along common escape routes, the lighting should use only protected circuits (see 44.3).

44.3 Protected circuits

A protected circuit should:

- a) consist of Category 2 cable in accordance with BS 8519:2010, Table 1;
- b) follow a route selected to pass only through parts of the building in which the fire risk is negligible;
- c) be separate from circuits provided for any other purpose.

45 Lift machine rooms and machinery spaces

Where a lift well is located within a common escape route, any lift machine room should be either above or outside of the common escape route.

Lift machine rooms or machinery spaces should conform to the appropriate part of BS EN 81.

Hydraulic lifts designed without a machine room and which incorporate all of the plant and hydraulic oil reservoir within the lift well should not be used in blocks of flats having a single stair.

46 Communal heating, ventilation and air conditioning systems

COMMENTARY ON CLAUSE 46

The principal risks associated with communal heating, ventilation and air conditioning systems are concerned with the plant, equipment and distribution systems involved, particularly boiler rooms, heat exchange equipment, fuel storage, and distribution ducting.

Communal heating, ventilation and air conditioning systems should meet the following recommendations.

- a) Oil-fired boilers should be installed and maintained in accordance with BS 5410-1 and BS 5410-2.
- b) Gas-fired boilers should be installed and maintained in accordance with BS 6798 or BS 6644.
- c) Boiler rooms, other than those installed in accordance with BS 5410-2, should have adequate provision for the venting of smoke.
- d) Oil fuels should be stored in accordance with BS 5410-1, BS 5410-2 and BS 799-5.
- e) Solid fuel should be stored in bunkers protected by non-combustible walls of sufficient thickness to prevent heating of the fuel by nearby boilers or steam pipes.
- f) Bulk storage of liquefied petroleum gas should be in accordance with the UKLPG guidance [N2] and HSE guidance note CS4 [N3].
- g) Ducts for engineering and building services should be in accordance with BS 8313; ducts and ductwork for ventilation and air conditioning should be in accordance with Clause 21.

NOTE With emerging technology in heating design, it might be advisable to consider in the design of a boiler room and ancillary spaces the possibility of a future change to other fuels.

47 Refuse storage, disposal and incineration

Provision should be made for the safe storage and disposal of refuse from dwellings.

Refuse storage, disposal and incineration should meet the following recommendations.

- a) Refuse storage chambers, refuse chutes and refuse hoppers should be sited and constructed in accordance with BS 5906.
- b) Refuse storage chambers should be approached solely from the outer air and should be separated from other parts of the building in accordance with Table 15. Access to refuse storage chambers should not be sited adjacent to escape routes or final exits or near to windows of dwellings.
- c) Refuse chutes and rooms provided for the storage of refuse should be separated from other parts of the building in accordance with Clause 13. They should not be located within or accessed directly from common stairs. Rooms containing refuse chutes or provided for the storage of refuse should be approached only by way of a protected lobby having not less than 0.2 m² of permanent ventilation or suitable mechanical alternative.
- d) In low-rise, multi-stair blocks, where rooms are provided for the storage of refuse (in lieu of a refuse chute system), any access lobby to such a room should be of the smallest size possible in order to prevent its use for the storage of refuse. Access to such rooms should not be by way of a dead-end corridor.

NOTE BS 5906 recommends that a refuse chute system is provided in blocks of more than four storeys: refuse hoppers are provided on each storey served by the refuse chute, with the refuse falling through the chute into a refuse storage chamber located at a level accessible directly by refuse disposal vehicles.

- e) Refuse incinerators should be located in a separate building.

48 Car parks and domestic garages

COMMENTARY ON CLAUSE 48

Car parks and domestic garages within or adjoining a building pose additional fire risks to a building.

A covered car park in a single-stair building served by the stair or lift needs to be provided with permanent cross-ventilation.

NOTE 1 Attention is drawn to the Petroleum (Consolidation) Regulations 2014 [36], which might require licensing for car parks and domestic garages together with any storage of petrol in cans, drums or other receptacles. This might be enforced through the Petroleum Licensing Authority for the area.

NOTE 2 Attention is drawn to the Dangerous Substances and Explosive Atmospheres Regulations 2002 [37], which might be applicable during the design of the car park in order to limit any fire risk assessed under these regulations.

48.1 Car parks within or adjoining buildings

Any car park within or adjoining the building (whether required to be licensed or not) should:

- a) have any external openings situated so as not to endanger any escape route or final exit from the residential accommodation;
- b) have adequate provision in accordance with Clause 14 for venting smoke;
- c) be provided with suitable access for fire-fighting (see Section 8);

- d) be provided with fire resistance as follows:
- 1) a minimum of 60 min fire resistance for basement car parks that are no more than 10 m in depth; or a minimum of 90 min fire resistance for basement car parks that are more than 10 m in depth;
 - 2) a minimum of 60 min fire resistance for any open-sided car park within a building;
 - 3) a minimum of 60 min fire resistance for enclosed car parks within a building up to 18 m in height; a minimum of 90 min fire resistance for enclosed car parks within a building up to 30 m in height; and 120 min fire resistance where the building is more than 30 m in height (though this may be reduced to 90 min fire resistance for elements not forming part of the structural frame).

NOTE See 7.5 for small buildings and connections to car parks.

48.2 Domestic garages adjoining buildings

Where a door is provided between a domestic garage and a house, either:

- a) the floor of the domestic garage should be laid to allow fuel spills to flow away from the door to the outside; or
- b) the door opening should be placed at least 100 mm above the domestic garage floor level.

The wall and any floor should have 30 min fire resistance with a self-closing fire door.

NOTE 1 A covered car park in a single-stair building served by the stair or lift needs to be provided with permanent cross-ventilation.

NOTE 2 These recommendations do not cover car lifts or car stacking systems.

Section 8: Access and facilities for fire-fighting

49 General recommendations for fire-fighting facilities

COMMENTARY ON CLAUSE 49

Fire-fighters need to be able to reach a fire quickly with their equipment. Physical safety and lives, both those of the fire-fighters and those of the occupants of the building, and the preservation of the building and its contents, can be jeopardized by delays in reaching the area of the fire.

When designing new buildings and provisions for occupant evacuation, account should be taken of the requirements for fire and rescue service access into and around buildings for fire-fighting purposes.

Fire-fighting facilities should be selected and designed to assist the fire and rescue service in protecting life, protecting fire-fighters, reducing building losses, salvaging property and goods and minimizing environmental damage. Early consultation with the appropriate approving authorities (including the fire and rescue service and building control bodies) is advised when deciding which facilities should be provided.

NOTE 1 The exact choice of facilities depends on the use, size or layout of the building, the nature of its contents, and the site upon which it is situated.

Fire-fighting facilities should include, where appropriate:

- a) the provision of vehicular access for fire appliances to the perimeter of the building or site;
- b) provision of easy and speedy entry to the site and/or the interior of the building for fire-fighters and their equipment;
- c) provision of and access to sufficient supplies of a fire-fighting medium, as determined by a risk assessment;

NOTE 2 The usual fire-fighting medium is water, but other media might be required.

- d) means of enabling fire-fighters, once they have entered a building, to reach any point within that building in the shortest time possible, including the provision of fire-fighting lifts, where appropriate;
- e) means of ensuring that once fire-fighters have arrived at a location within a building, they can remain there in relative safety whilst they carry out their fire-fighting operations;
- f) provision for fire and rescue service communications;
- g) provision of facilities to release, or extract, smoke and heat from the building or site;
- h) provision for removing spent fire-fighting extinguishing medium (e.g. drainage).

50 Fire-fighting access

50.1 Access for fire appliances

50.1.1 General

Every building should be provided with suitable access for fire-fighting purposes; roadways should be constructed to allow access for fire appliances, and entry points to buildings should be readily identifiable to the fire and rescue service.

The provisions made for vehicular access should be determined according to whether or not a fire main is provided (see **50.1.2**, **50.1.3** and **51.1**).

The location of residential buildings can create issues for fire and rescue service access due to the increased demand for the development of areas with restricted access. Fire appliance access to buildings should be discussed with the fire and rescue service at the concept stage.

50.1.2 Buildings not fitted with fire mains

Houses not fitted with fire mains should allow access for a fire appliance to within 45 m of all points within the house, measured on a route suitable for laying hose.

Blocks of flats not fitted with fire mains should have vehicle access for a fire appliance not more than 45 m from all points within each dwelling, measured on a route suitable for laying hose.

NOTE If the internal layout of partitions, fittings, etc. is not known when plans are deposited, direct distances may be used for assessment. The direct distance is taken as two thirds of the travel hose laying distance.

Where sprinklers in accordance with BS 9251:2014 or BS EN 12845 (see **11.2**, Table 2) are fitted throughout a house or block of flats:

- a) the distance between the fire appliance and any point within the house (in houses having no floor more than 4.5 m above ground level) may be up to 90 m;
- b) the distance between the fire and rescue service pumping appliance and any point within the house or flat may be up to 75 m (in houses or flats having one floor more than 4.5 m above ground level).

50.1.3 Buildings fitted with fire mains

Fire mains enable fire-fighters within a building to connect their hoses to a water supply. In buildings fitted with fire mains, pumping appliances should have access to the perimeter at points near the mains, so that fire-fighters can enter the building to make a hose connection from the fire appliance to pump water into the main. Fire mains should be provided in accordance with **51.1**.

Buildings fitted with dry fire mains should have access for a fire appliance to within 18 m of each fire main inlet connection point, typically on the face of the building close to the entrance point leading to the fire-fighting shaft, with the inlet visible from the fire appliance.

Multi-storey buildings fitted with wet fire mains should have fire appliance access:

- a) within 18 m of, and within sight of, a suitable entrance giving access to the wet fire main; and;
- b) within sight of the inlet for the emergency replenishment of the suction tank for the wet fire main.

50.2 Access for fire-fighters

50.2.1 General

Buildings with a floor higher than 18 m above fire and rescue service access level, or with a basement more than 10 m below fire and rescue service access level, should be provided with fire-fighting shaft(s) containing fire-fighting lifts.

NOTE General recommendations for fire-fighting shafts are given in BS 9999.

A sufficient number of fire-fighting shafts should be provided to meet the maximum hose distance set out in 50.2.2, and at least two fire-fighting shafts should be provided in buildings with a storey of 900 m² or more in area.

Security features can cause problems for fire-fighters trying to access the building in an emergency. To avoid potential conflicts between access and the security arrangements for the building, the local fire and rescue service should be consulted at an early stage in the design of the building.

The designated route to the fire-fighting shaft should be clearly indicated by appropriate signage or other recognizable means where the entrance is not directly accessed from the outside, and in a location visible from a fire appliance.

50.2.2 Siting of fire-fighting shafts

Fire-fighting shafts should serve every storey through which they pass.

Access should be provided to enable fire-fighters to create a bridgehead from where they can operate at a level immediately above or below the fire floor. The local fire and rescue service should be consulted regarding access to fire-fighting shafts.

Wherever practicable, fire-fighting shafts should be sited against an exterior wall. Where this is not practicable:

- a) the route from the fire and rescue service entrance to the fire-fighting shaft should be as short as possible; and
- b) the fire-fighting shaft should be protected by fire-resisting construction to prevent fire from affecting the route or cutting off the means of escape for either the fire and rescue service or other persons within the building.

Where fire-fighting shafts are required they should be located such that the following recommendations are met.

- 1) If the building is fitted throughout with a sprinkler system in accordance with BS 9251:2014 or BS EN 12845 (see 11.2, Table 2), then sufficient fire-fighting shafts should be provided that every part of every storey is no more than 60 m from a fire main outlet in a fire-fighting shaft, as measured on a route suitable for laying hose.
- 2) If the building is not fitted with sprinklers, then every part of every storey should be no more than 45 m from a fire main outlet contained in a protected stairway and 60 m from a fire main in a fire-fighting shaft, as measured on a route suitable for laying hose.

NOTE 1 In order to meet the 45 m hose criterion in b), it might be necessary to provide additional fire mains in escape stairs. This does not imply that these stairs need to be designed as fire-fighting shafts.

NOTE 2 If the internal layout of partitions, fittings, etc. is not known when plans are deposited, direct distances may be used for assessment. The direct distance is taken as two thirds of the travel hose laying distance.

NOTE 3 In blocks of flats the protected corridor or protected lobby provided for means of escape purposes is assumed to be the fire-fighting lobby, and it is not necessary to provide an additional fire-fighting lobby between the protected corridor or protected lobby and the fire-fighting stair.

50.3 Construction of fire-fighting shafts

50.3.1 General

Fire-fighting shafts should be constructed in accordance with the recommendations given in BS 9999 for the fire resistance, resistance to damage of enclosing and separating partitions, and floor coverings of fire-fighting shafts.

Any glazing incorporated into the fire-fighting shaft should be in accordance with Clause 22.

Only services associated with the fire-fighting shaft, such as ventilation systems and lighting for the shaft, should pass through or be contained within the fire-fighting stair.

50.3.2 Fire-fighting stairs and lifts

50.3.2.1 Fire-fighting stairs

Fire-fighting stairs should be sufficiently wide to be easily used by fire-fighting personnel carrying fire-fighting equipment. Fire-fighting stair enclosures should be provided with facilities for smoke control (see Clause 14) so that they remain relatively smoke-free.

A fire-fighting stair should not contain any cupboards or provide access to service shafts serving the remainder of the building.

To prevent smoke from basement storeys penetrating the stair enclosure above ground level, fire-fighting stairs serving floors both above and below ground level should be separated at ground floor level by a fire door.

Fire-fighting stairs should be designed in accordance with BS 5395-1, with a width between the walls or balustrades of not less than 1.1 m. This width should be kept clear for a vertical distance of 2.0 m, as measured from the pitch line or landing floor level, with the following exceptions:

- a) stringers, each intruding into the stair by not more than 30 mm; and
- b) handrails, each intruding into the stair by not more than 100 mm.

Scissor stairs should not be used to form a fire-fighting staircase as their design includes features that are not compatible with the recommendations for a fire-fighting stair.

Helical stairs/winders should not be used for fire-fighting stairs.

Emergency escape lighting in fire-fighting stair enclosures should be provided in accordance with BS 5266-1.

Both the fire-fighting lift and stair are used together during fire-fighting operations. Because it is the line of retreat if the fire-fighting lift fails, the fire-fighting stair should serve every storey that is served by the fire-fighting lift.

Signage numerically indicating the floor level should be provided within the fire-fighting stair.

50.3.2.2 Fire-fighting lifts

A fire-fighting lift installation includes the lift car itself, the lift installation within the well and the lift machinery spaces, together with the lift control system and the fire and rescue service communications system. Fire-fighting lift installations should conform to BS EN 81-72.

NOTE 1 A fire-fighting lift, unlike a normal passenger lift, is designed to operate, for as long as is practicable, when there is a fire in parts of the building beyond the confines of the fire-fighting shaft, as it is used to transport fire-fighters and their equipment to a floor of their choice. The floors to be served by the fire-fighting lift are assumed to be determined as part of the design of the building for fire. Fire-fighting lifts might not need to serve a storey on which there is no entrance to any accommodation or the top storey of the building if it consists exclusively of plant rooms.

The fire-fighting lift may open directly into the protected corridor or protected lobby, but the fire-fighting lift landing doors should not be placed more than 7.5 m from the fire-fighting stair and should not be located within the stair enclosure, even if the building is being refurbished.

The use of dual-entry fire-fighting lifts is not recommended in residential buildings.

It is important to ensure that the fire-fighting lift remains operational. The power supply of the lift and lighting should consist of primary and secondary (emergency, stand-by or alternative) supplies. There should also be means to minimize the effect of water penetration into the fire-fighting lift well.

NOTE 2 The minimum flow rate from a wet fire main recommended in BS 9990:2015 is 1 500 L/min, and this is considered to be representative of the maximum possible flow rates into the lift well in the worst case conditions. The flow from a dry main is dependent on a number of factors including the pumping pressure and height of the building. The actual flow of water into the lift well is also dependent on the location of the outlet. These factors can be taken into account when assessing potential water ingress into the lift well.

Access points into the fire-fighting lift well should be provided in accordance with BS EN 81-72.

Where a fire-fighting lift is intended to run blind through a number of floors, it should be determined that there is adequate access for fire-fighting personnel to set up a bridgehead on any required floor (see Note 1). Where lifts are proposed to run blind there should be early consultation with the local fire and rescue service.

NOTE 3 BS EN 81-72:2015 requires that when the distance between consecutive landing doorsills exceeds 7 m, intermediate emergency doors be provided, such that the distance between sills is not more than 7 m.

51 Water supplies for fire and rescue service fire-fighting use

51.1 Fire mains

Fire mains should be designed and installed in accordance with BS 9990.

Fire mains should be installed in buildings where any floor is higher than 18 m above ground level. Where there are no floors higher than 50 m above ground level, wet or dry fire mains may be installed. Where there are floors higher than 50 m above fire-fighting access level, wet fire mains should be installed because of the pressures required to provide adequate water supplies at the landing valves at upper floors and also to ensure that water is immediately available at all floor levels.

Fire mains should be installed in any building provided with a fire-fighting shaft and located within the stair enclosure (see Figure 35).

Figure 35 Components of a residential fire-fighting shaft

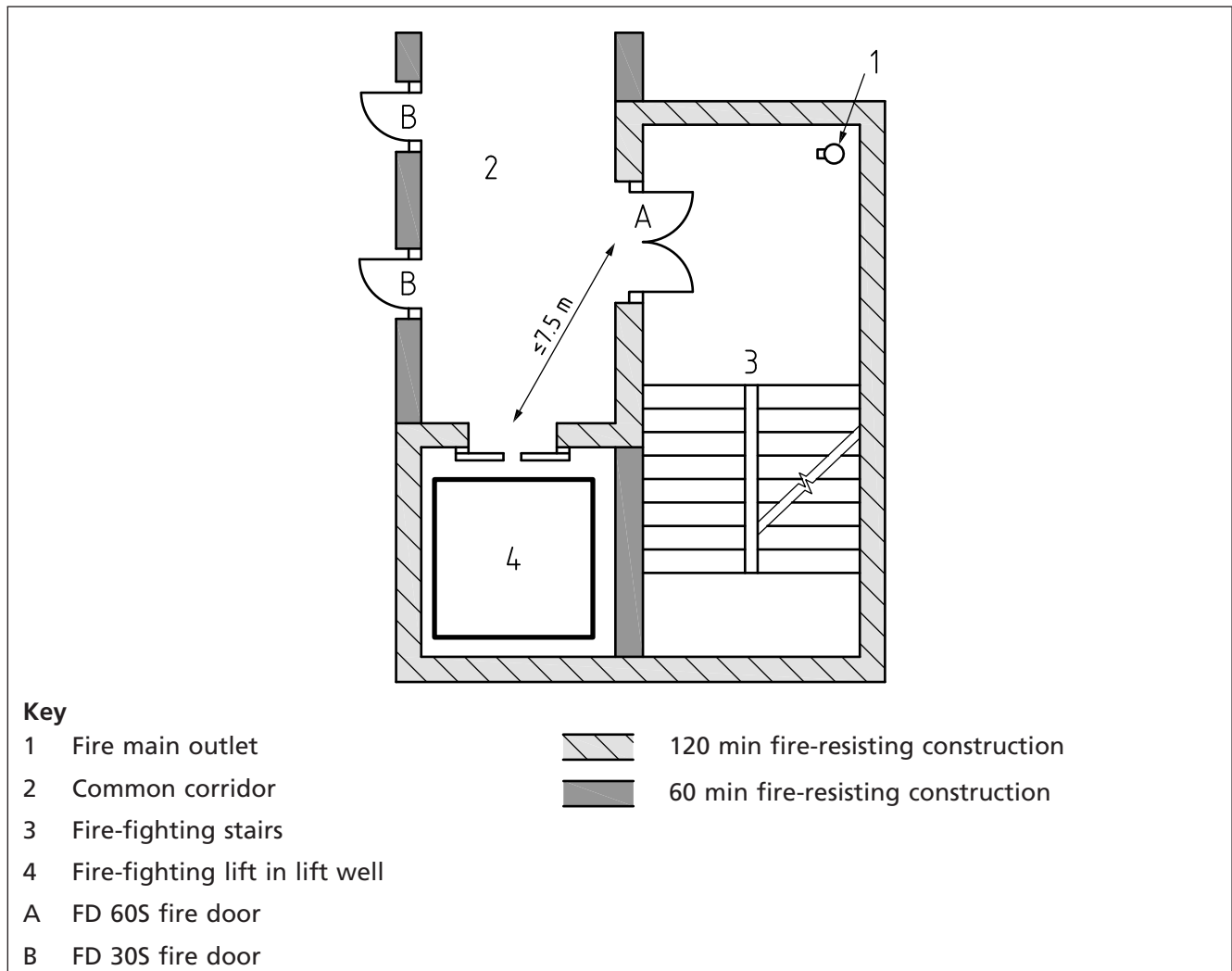

51.2 Location and access to external water supply

All premises should be provided with a supply of water for fire-fighting. Fire-fighters have to lay out hose between the water supply and the fire appliance, so these distances should be kept to a minimum.

Hydrants should be located in positions that are near to building entry points (including entry points to fire-fighting shafts containing fire mains) and fire appliance parking positions as follows.

- For buildings provided with dry fire mains, hydrants should be provided within 90 m of dry fire main inlets.
- For buildings not provided with fire mains (or where the building is fitted with a wet fire main), hydrants should be provided within 90 m of an entry point to the building and not more than 90 m apart.

Water mains and hydrants should be capable of delivering a sufficient flow of water to enable effective fire-fighting to be undertaken. If the water supply takes the form of a static tank or dam, the capacity should be related to the size of the building and the risk involved. An unlimited and guaranteed natural water source providing the right quantities is also expected to be acceptable, subject to access and hard-standing for the fire appliances being provided.

Prior to the construction of the building, consultation should be undertaken with the water authority, fire and rescue service and building control body on the nature of the water supply and the quantities or capacity to be provided.

The water supply should comprise one or a combination of the following:

- 1) hydrants provided by the water undertaker on the street mains;
- 2) private hydrants designed and installed in accordance with BS 9990, ideally forming part of a ring main system;
- 3) a static or natural water supply.

All hydrants should have signage in accordance with BS 3251.

52 Information for fire and rescue service use

In large or complex residential buildings, particularly high buildings or those having extensive accommodation below ground level, it is of considerable advantage to the fire and rescue service if appropriate information about the building is made available to them. Where appropriate this should include:

- a) simple floor plan layouts, indicating any relevant fire resistance provisions, internal access provisions, fire-fighting facilities, building services and any specific hazards;
- b) relevant information (including operating instructions) relating to equipment/fixed installations provided for means of escape or fire-fighting;
- c) information regarding the implications of any fire engineering strategy on the performance of the building during a fire, e.g. reduced fire resistance of elements of structure or areas of the building with additional fire protection measures;
- d) information relevant to preventing environmental damage;
- e) relevant information (including operating instructions) relating to lifts provided for means of escape or fire-fighting. Where evacuation or fire-fighting lifts are installed, these should be clearly signed at the fire service access level; relevant information should be available detailing the locations of the main switch, rescue controls and machinery spaces.

Depending on the structural complexity of the building, it might also be appropriate to make schematic fire system plans available. An isometric or cut-away view might be appropriate as the best means of illustrating the building. Fire protection facilities shown on any of these plans should be labelled, and where plan symbols are used, a key to the symbols should be provided.

Where a plans box is used to store this information on site, a photo-luminescent identification sign should be provided on the outer face of the box door. This sign should remain prominent so that if the building's lighting fails, the location of the box is still visible. Where a plans box is not used, the information pack should be clearly identified by an appropriate method.

Section 9: Management

COMMENTARY ON SECTION 9

Section 9 gives recommendations for actions to be taken by owners and occupiers of flats and maisonettes. It also provides recommendations for the owners and managers of buildings containing flats or maisonettes to help them to make the best use of the design features of the building.

Attention is drawn to Regulation 38 of the Building Regulations 2010 [1], and BS 9999 regarding guidance for designers on information to pass on to their clients concerning fire precautions designed into a building.

Guidance on the management of additional needs and disabilities is given in Annex E.

Advice to occupiers of domestic residential buildings on precautions against fire that they may take is given in Annex F.

53 Management of specialized housing

The fire strategy for all types of specialized housing should be based upon a realistic in-use management regime and the design process should ensure compatibility between the fire protection provisions and management.

A fire risk assessment should be conducted and appropriate evacuation and management measures should be adopted based on the results.

54 Evacuation of disabled occupants or occupants that require assistance to escape

Providing an accessible means of escape should be an integral part of fire safety management in all residential buildings. Fire safety management should take into account the full range of people who might use the premises, paying particular attention to the needs of disabled people.

NOTE 1 It is the responsibility of the premises management to assess the needs of all people to make a safe evacuation when formulating evacuation plans.

An evacuation plan should not rely on the assistance of the fire and rescue service. This is an important factor that should be taken into account in the building design.

It cannot be assumed that facilities provided in a building to make it accessible will be usable in a fire evacuation. For example, lifts that are not appropriately designed for emergency evacuation might not be usable for evacuation. This should be taken into account at the design stage when it is relatively easy to incorporate accessible escape features which will make evacuation planning more effective, an evacuation easier to manage and help to preserve the dignity of disabled people in an evacuation.

NOTE 2 For evacuation lifts, see 8.4.

Many people other than wheelchair users are considered to have mobility impairments. This category includes people who can use stairs but might not be able to reach a place of ultimate safety in the normal movement times used to calculate evacuation times. Awareness of this is particularly relevant if a time-to-safety calculation is used to assess the evacuation plans in the premises. It should be therefore determined whether any or all of the following are necessary in the design of an escape route:

- a) the use of horizontal evacuation to a different fire compartment;
- b) the use of lifts;

- c) the use of additional measures to ensure that all escape routes are accessible, e.g. adding ramps where necessary;
- d) the implementation of extra hand rails and step edge markings.

In specialized housing a log should be kept of any residents who are likely to require assistance in the event of a fire in order to evacuate their dwelling and/or the building. The fire and rescue service should be made aware of the log and its location. The log may form part of the fire safety manual for the premises.

55 Residents

The responsible person should advise residents formally of the fire safety arrangements for the building, what to do to prevent fires occurring, and what to do in the event of a fire. This information should be contained within a handbook which should also address the potential for particular problems arising where residents employ sub-contractors, e.g. for fit-out work.

NOTE 1 The responsible person in this instance could be the owner, occupier or management of the building.

NOTE 2 Annex F contains information that can be given to owners and occupiers of dwellings in residential buildings (including flats) along with examples of fire instruction notices for residential buildings.

56 Caretakers

Where a caretaker or other person is employed to maintain common areas within a building, the responsible person should advise such persons formally of the fire safety arrangements for the building.

NOTE The responsible person in this instance could be the owner, occupier or management of the building.

57 Maintenance of fire protection measures

It is essential that the fire protection measures integrated in a building function in a fire. The fire protection measures should be inspected on a regular schedule to ensure that they are available and functional at all times.

Inspections should include, but not necessarily be limited to, compliance with the following recommendations.

- a) Escape routes should be kept clear at all times. Storage of goods and equipment could block exits and provide an unwanted fire load and potential source of ignition.
- b) Door locks, panic bars and automatic door release mechanisms should be maintained so that they are easily openable in an emergency.
- c) Whenever additional or replacement services breach compartment walls or floors, the integrity of fire separation should be maintained through the use of appropriate fire-resisting materials in spaces where breaches of compartmentation have occurred.
- d) Fire safety equipment such as fire extinguishing and fire main inlet and outlet valves should not be obstructed by stored goods, machinery or parked vehicles.
- e) All fire safety equipment, e.g. fire alarms, emergency escape lighting, automatic fire suppression systems, smoke control systems and fire

extinguishers, should be maintained and tested in accordance with the relevant standard by competent persons.

- f) Fire doors should be maintained in accordance with **24.1**.

NOTE 1 When a fire occurs in the premises, the safety of occupants and their means of escape rely heavily on the flat front doors retaining their self-closing devices and their fire resistance.

- g) Evacuation lifts should be suitably maintained and have periodic tests to ensure their operation in the event of a building evacuation.

NOTE 2 Ongoing control over the repair, maintenance and replacement of doors, self-closers, sprinklers, alarms and other fire safety equipment is an important issue that needs to be effectively planned, monitored and reviewed by the responsible person in order to ensure ongoing compliance with the Regulatory Reform (Fire Safety) Order 2005 [2] and its equivalents in Scotland [6] and Northern Ireland [7]. This might include the need to ensure the issue is specifically covered in leases and tenancy agreements to make certain that appropriate remedial works can be carried out as the need arises.

Where it is probable that significant quantities of combustible material (such as junk mail and pushchairs) will be present in the common areas, means should be taken to prevent the development and spread of any fire that might develop there.

58 Maintenance of building plant and equipment

Fire can start in machinery and equipment which is not adequately maintained or cleaned. The responsible person should check that the equipment and plant is regularly maintained.

NOTE Attention is drawn to the Gas Safety (Installation and Use) Regulations [32] and to BS 7671. These regulations require electrical and gas installations to be regularly examined by a competent person who, if not qualified, has to have authority to engage a qualified person to carry out any investigations and/or repairs deemed necessary for safety reasons.

59 Ensuring that systems respond properly in an emergency

COMMENTARY ON CLAUSE 59

It is essential that in the event of a fire, all fire safety provisions function as intended and all fire emergency procedures are implemented in order to facilitate appropriate action. As it can never be foreseen when a fire might occur, it is part of the role of the responsible person to ensure that all of the built-in passive and active safety systems operate (or are effective) on demand.

The responsible person in this instance could be the owner, occupier or management of the building.

59.1 Escape routes

The following recommendations should be met in order to ensure that escape routes are available for use at all times when the building is occupied.

- a) All escape routes should be kept free from obstruction.
- b) Goods, materials, unwanted furniture, etc. should not be stored within escape routes. Any obstruction should be removed immediately.
- c) All escape routes should be inspected frequently. A log detailing the frequency and results of inspection should be included in the fire safety manual and corrective measures should be taken where necessary.

- d) Fire doors that are intended to be kept closed should remain closed and unobstructed.
- e) Fire doors on hold-open devices should be operable and should be unobstructed.
- f) The exterior of the building should be inspected to ensure that final exits and routes to assembly points are not blocked.
- g) Entrance halls, lobbies or corridors should not contain furniture or fittings that would reduce, at any point, the required exit width.
- h) In a building or part of a building served by a single stair, and in fire-fighting stairs, furniture should not be placed within the stair enclosures and exits therefrom.
- i) Fire safety signs and notices, fire extinguishers, emergency escape lighting, fire doors and shutters should not be obscured.
NOTE Further information and guidance regarding fire safety signs and notices is given in the Building Regulations 2010, Approved Document B [14].
- j) Seating areas should not be provided within escape corridors.
- k) Maintenance and redecoration of surface finishes and floor coverings should not use materials that might propagate surface spread of flame and/or fire, or adversely affect the means of preventing such propagation.
- l) The floor surfaces (including stairs, stair nosings and ramps) within escape routes should be maintainable, even and non-slip. Resilient floor surfaces should be maintained in accordance with BS 6263-2. Only emulsion polish (not wax polish) should be used on such floor surfaces.

59.2 Maintenance of fire safety equipment and provisions

Planned inspection, maintenance and testing procedures should be established and used to ensure that all fire protection systems can operate effectively when required. Arrangements should be made for all fire safety equipment, installations and systems (including fire detection systems, automatic fire suppression systems, door control mechanisms, smoke control systems, evacuation and fire-fighting lifts, emergency escape lighting, standby power systems, escalators, and all passive fire protection provisions) to be inspected and tested on a regular basis by a competent person. Material alterations, additions, repairs or modifications to services and equipment should be carried out only by competent persons.

The following British Standards should be used for the routine maintenance, inspection and testing of particular systems:

- a) BS 5839-1:2013 and BS 5839-6:2013 for fire detection and fire alarm systems;
- b) BS 5266-1 for emergency escape lighting systems;
- c) BS 9251:2014 or BS EN 12845 for automatic sprinkler systems in residential and domestic buildings;
- d) DD 8458-1 for watermist systems ⁷⁾;
- e) BS 8214 for fire doors;
- f) BS 7273-4 for fire door automatic release mechanisms;

⁷⁾ At the time of publication of BS 9991, DD 8458-1 is undergoing conversion to a full British Standard as BS 8458.

- g) the relevant part of BS EN 12101 for smoke control systems;

NOTE Further information regarding testing, inspection and maintenance of mechanical smoke ventilation systems is given in BS 9999 and the Smoke Control Association publication Guidance on smoke control to common escape routes in apartment buildings (flats and maisonettes) [18].

- h) BS 5306-3 for portable fire extinguishers;
i) BS 9990 for fire hydrants and fire mains;
j) BS 8524 for active fire curtain/barrier assemblies.

59.3 Fire-fighting access and equipment

One or more of the passenger lifts in the building may be made available for the exclusive use of fire-fighters in an emergency, when a switch at fire and rescue service access level (usually the entrance level) marked "Fire-fighting lift" is operated. Any lift that is designated as a fire-fighting lift should receive early attention when it breaks down. Regular inspections of the fire-fighting lift switch should be made to check for any unauthorized use. Operational tests, routine inspections and maintenance of fire-fighting lifts should be carried out in accordance with BS EN 81-72 and the lift owner's manual.

Wet or dry rising fire mains and the accompanying inlet and/or outlet boxes, together with any foam inlets to oil-fired boilers, should be regularly inspected for damage and repaired where necessary. Where provided, outlet straps to fire mains should be checked to see that they are in place and secure.

Fire and rescue service access roads and gates leading to the building can become seriously obstructed by the indiscriminate parking of cars and other vehicles using the site. Management procedures should exercise control over the parking of vehicles on private access roadways also used for fire and rescue service access, so that fire appliances are not obstructed in an emergency and are able to proceed to within the required distance of fire main, foam or other inlets. In the interests of security, unauthorized entry along such roadways should be restricted, in agreement with the fire and rescue service, if deemed necessary.

NOTE Control and enforcement of parking restrictions can prove difficult, but the provision and maintenance of notices giving clear instructions regarding parking arrangements can go some way to alleviating this problem.

59.4 Contingency planning

In some buildings, particularly complex ones and those with fire engineered solutions, where the effective operation of fire safety systems is critical, it might be necessary to implement contingency arrangements in the event of safety systems being unavailable, e.g. due to maintenance or repair. The fire risk assessment should be used to identify critical systems and inform contingency planning in terms of additional management actions and timescales.

Section 10: Building works: Material alterations, extensions, refurbishment, change of use, disuse, decommissioning and demolition

60 Design of works

Alterations to a building should retain at least the level of fire safety protection that was in place before the alterations were carried out; it can, however, be beneficial to improve fire safety through building works, wherever practicable.

A fire risk assessment should be carried out regarding the impact of any proposed alterations to ensure that:

- a) no unacceptable existing fire risks are continued;
- b) existing fire safety measures are not compromised; and
- c) no new fire risks are created.

NOTE 1 Attention is drawn to the Building Regulations 2010, Approved Document B [14].

NOTE 2 Attention is also drawn to buildings that are covered by the Regulatory Reform (Fire Safety) Order [2] and its equivalents in Scotland [6] and Northern Ireland [7], which are required to undergo a fire risk assessment for their post-altered state.

61 Change of use

In the event of a change of use, a new fire risk assessment should be conducted to cover the changed circumstances.

NOTE Attention is drawn to the Building Regulations 2010 [1] and equivalent regional variations ([3] to [5]). Changing the use of a building might alter the regulations which are applicable to the building.

62 Refurbishments

When undertaking a refurbishment, whether or not directly related to fire safety, an assessment should be made as to whether fire safety improvements are needed.

During refurbishment and minor remodelling work, the core principles of compartmentation and fire separation should be observed.

NOTE Even relatively minor modifications could compromise fire-resisting elements of compartmentation and separation. Management control, approval and inspection of the original design and construction, and of any subsequent modifications, are therefore all very important if fire safety is to be maintained to at least the minimum levels defined in this British Standard.

63 Dwellings in disuse and areas decommissioned

COMMENTARY ON CLAUSE 63

Despite the supportive value of automatic detection and fire extinguishing systems, surveillance by human presence and immediate action taken in the very first stages of fire represent the most effective way of limiting its effects. When the human element is not present, as in the case of an unoccupied dwelling or a decommissioned part of a building, the occupants of the remainder of a building or complex are deprived of a first line of defence against fire.

Even if a temporarily discontinued occupancy results in a reduction of the combustibles normally expected to be present in a dwelling, the importance of automatic fire protection within that dwelling or area is increased rather than diminished, particularly if work such as shop fitting is in progress.

Where a building is in disuse, surveillance by staff should be intensified to prevent any form of careless practice and to ensure that protective systems remain fully operative.

Any decommissioned area, unoccupied dwelling, or dwelling that is in the process of being fitted out should be either:

- a) physically separated from the rest of the building by construction having not less than 60 min fire resistance; or
- b) protected by other fire protection measures as agreed by the relevant enforcing authorities.

In either case, the unused part of the building should be subject to routine inspection, as determined by a risk assessment.

64 Managing building work and material alterations

Experience demonstrates that fires are more likely to occur when buildings are undergoing works of maintenance and alteration, and therefore building work and material alterations should be managed and carefully monitored.

Designers and contractors should be made aware of the existing fire safety features of the building.

A fire risk assessment should be conducted that identifies and deals with all risks across the duration of the building project.

Building works should be continuously monitored to prevent the creation of unplanned extra and undue risks.

NOTE 1 Attention is drawn to the Construction (Design and Management) Regulations 2015 [38] and the Construction (Design and Management) Regulations (Northern Ireland) 2007 [39].

NOTE 2 Further guidance is given in BS 9999, HSE publication HSG 168 [40] and the Construction Confederation and Fire Protection Association publication Fire prevention on construction sites – The joint code of practice on the protection from fire of construction sites and buildings undergoing renovation [41].

65 Building works to occupied or partly occupied buildings

Where works are to be conducted to an existing occupied building or where a new building might be partly occupied before full completion, added vigilance against fire risk is necessary.

A fire risk assessment should be mutually evolved between the responsible person for the building and the contractor. This risk assessment should be continually reviewed during the period of occupation. Where such an assessment process shows that the safety of persons is difficult to ensure then alternative approaches should be implemented. These might include the provision of extra fire precautionary measures or the prohibition of contemporaneous occupation.

NOTE Further guidance is given in BS 9999.

Annex A
(informative)
A.1

Methods of smoke ventilation

General

In residential buildings designed with a stay put strategy, only the occupants from the dwelling of origin evacuate and all other occupants remain in place, unless either they are directly affected by heat or smoke, or the fire and rescue service deem it necessary to evacuate other residents at a later stage. As a result of this strategy, special provisions are necessary to ensure that the stairway(s) remain relatively free from smoke and heat in the event of a fire within a dwelling. This is of particular importance where only one staircase serves the building.

The implementation of a smoke control system can be used as one such provision. The primary objective of smoke control in residential buildings is to protect the staircase enclosure; however, the adjacent protected corridor or lobby might also gain some protection.

For extended corridor scenarios, the primary objective of the smoke control system is to protect both the common corridor and the staircase enclosure for means of escape.

NOTE Further information regarding smoke control is given in the Smoke Control Association publication Guidance on smoke control to common escape routes in apartment buildings (flats and maisonettes) [18].

A.2 Natural and mechanical smoke ventilation

A.2.1 General

There are two main methods of smoke ventilation, as follows.

- a) Natural smoke ventilation systems. The general principle is that a vent is provided to the lobby or corridor adjoining the stair to facilitate the removal of smoke through the vent prior to it entering the staircase enclosure. The vents can be located either on an external wall or in a vertical shaft. A vent is also provided from the top storey of the stairway to outside air, to act as an outlet if smoke enters the staircase or as an inlet to make the system more efficient prior to the arrival of the fire and rescue service.
- b) Mechanical smoke ventilation systems. This can take the form of either a pressure differential system (see A.2.2) or a mechanical smoke ventilation system (see A.2.3).

A.2.2 Pressure differential systems

A pressure differential system can be in the form of either a pressurization system or a depressurization system. A depressurization system decreases the air pressure within the area of a fire or its adjacent areas so that it is lower than the air pressure within the protected area. A pressurization system is usually used to protect staircases.

A pressurization system can be provided within the staircase or fire-fighting shaft enclosure. The general principle is that it injects air into these spaces to create a higher pressure than in the adjoining spaces. This prevents any combustion products from entering the staircase or fire-fighting shaft. For these systems it is necessary to determine not only where the fresh air supply for pressurization is to be introduced into the building, but also where that air and smoke will leave the building and the paths it will follow in the process. Pressurization systems can be designed and installed in accordance with BS EN 12101-6.

A.2.3 Mechanical smoke ventilation systems (MSVS)

The general principle is that a vent is provided to the lobby or corridor adjoining the stair to facilitate the removal of smoke through the vent prior to it entering the staircase enclosure. An MSVS uses fans to provide ventilation, rather than relying on buoyancy and wind forces as natural ventilation does. Most systems use a vertical shaft.

Adverse wind or building stack pressures are less likely to affect a pressure differential system or an MSVS than a natural smoke control system.

A.3 Extended corridors

Where the design of a block is such that travel distances exceed those shown in Figure 6 and Figure 7, a fire engineered MSVS may be provided to compensate for the extended travel distance.

The primary objective for this type of system is to return the extended corridor and the associated staircase enclosure to tenable conditions for means of escape and rescue purposes. Information regarding tenability criteria (such as temperature and visibility) for assessing the performance of the MSVS is given in PD 7974-6.

NOTE 1 Guidance on tenability criteria for fire-fighters is given in PD 7974-5 and the Smoke Control Association publication Guidance on smoke control to common escape routes in apartment buildings (flats and maisonettes) [18].

It is important to ensure that the location of the inlet air in relation to the point of extract does not create dead spots in the protected zone.

NOTE 2 Recommendations for primary and secondary power supplies are given in Clause 15.

A.4 Considerations for the selection of an MSVS

When selecting an MSVS, it is important to take into account a number of factors regarding the design and functionality of the system.

For the MSVS to operate effectively, account needs to be taken of the route of the exhaust air, the inlet replacement air supply and the air flow within the space being ventilated. A judicious selection of the MSVS ventilation rate and adequate provision for replacement air is essential to ensure that air is extracted from the protected lobby or protected corridor without allowing smoke from the flat of fire origin to be drawn in. The presence of smoke in the protected lobby or protected corridor can prove hazardous to occupants trying to escape. It is also important to ensure that replacement inlet air is provided, with its location being determined in relation to the point of extract, so that the system works to effectively extract smoke from the relevant space.

It can be beneficial to select an MSVS having a two-stage extract system incorporating a fire-fighter's control switch. Such a system can work in one of two ways: either through an extraction rate that remains constant throughout all of the different phases of a fire, or through an extraction rate that varies, depending on the stage and development of a fire. For example, during the early stages of a fire (means of escape phase) an MSVS might be designed to run at a preselected low extract rate, but incorporate the facility for fire-fighters (via a manual control point) to increase the extract rate (the function is often referred to as a boost facility) to aid fire-fighters when carrying out fire-fighting operations. This type of MSVS can also help in maintaining reasonable conditions for means of escape.

Where local extraction rate control is provided for fire-fighters, it needs to be ensured that extraction rates can be modified only by the responsible fire-fighting team.

It is important that the ventilation rate of an MSVS is decided through an assessment of any specific risks within the building and verification through a computational fluid dynamics (CFD) analysis or mathematical calculation. A CFD analysis is based upon building specific geometries and, ideally, includes a sensitivity analysis.

Factors covered by a sensitivity analysis are dependent upon whether the purpose of the MSVS is purely to protect the means of escape or whether the aim is also to aid fire-fighting operations.

When the sole purpose of an MSVS is to protect the means of escape, it is important that the following aspects are taken into account with regard to their effect on the ability of the system to meet its performance criteria:

- a) different fire locations (both close to and far from the point of extract);
- b) pressure differences across a flat front door with a variety of extraction rates;
- c) a negative wind coefficient at the stair head vent;
- d) fire pressure and increasing fire growth.

When the purpose of an MSVS is also to aid fire-fighting operations, it is important that the following aspects are taken into account with regard to their effect on the ability of the system to meet its performance criteria, in addition to those aspects given in a) to d):

- 1) a variety of door opening sizes for the stair or corridor door (when closed, partially open and fully open);
- 2) increased ventilation to a fire due to a broken window;
- 3) low-level ventilation to the stair.

NOTE There are numerous different types of fan-assisted system, including a mechanical extract/natural inlet and a mechanical extract/mechanical inlet system. Further information on these is given in the Smoke Control Association publication Guidance on smoke control to common escape routes in apartment buildings (flats and maisonettes) [18]. This document also includes information regarding system controls (control panels, indication/status panels, manual control points, etc.), which can be important factors when selecting an MSVS.

Annex B (normative)

Additional recommendations for property protection and business continuity

COMMENTARY ON ANNEX B

The recommendations given in this British Standard are primarily concerned with the protection of life. The provision of fire safety systems for life safety do not necessarily give adequate protection to property or the business carried out in the building. Therefore, the aim of this annex is to ensure that the potential for property and business loss is assessed so that risks are understood and acceptable. It is also important to understand that fire presents a significant challenge to any business. In communal dwellings a fire which is contained to the dwelling of origin can very easily cause damage which will affect the habitability of other dwellings, e.g. through the damage of shared services.

The insurance industry has produced various guides which are directed at property protection, arson and vandalism (including the Fire Protection Association publication Design guide for the fire protection of buildings: Essential principles [42], the CLG publication Arson control forum annual report [43], and the Arson Prevention Bureau publication How building design can reduce the threat from arson [44]).

Many insurers use the LPC design guide for the fire protection of buildings [25] as a basis for providing guidance to the building designer on what they require.

Further advice and guidance on the provision of fire precautions for the protection of property and the continuity of the business is given in BS 9999.

B.1 General

Continuing operations in the event of a fire is essential for any organization, and businesses should therefore have appropriate business continuity plans in place.

NOTE Further advice is given in BS 25999, which provides a basis for understanding, developing and implementing business continuity within an organization.

B.2 Fire risk assessment

COMMENTARY ON B.2

By carrying out a property protection and business continuity risk assessment, the consequences of fire on property and business loss can be highlighted to the owner, occupier, operator, tenant, designers and insurers.

The risk assessment for property protection and business continuity could be an extension to other risk assessments carried out for life safety as required under various legislation.

The primary method for examining the potential for property and business loss should be a fire risk assessment. This should account for the fire safety provisions in the building and the level of fire prevention management.

The risk assessment should take into account the existing fire safety systems and equipment in the building, and the level of fire prevention management intended for the building. It should be used to determine what overall fire safety systems and equipment are required, what function they have in relation to property protection and what management responsibilities are required to maintain and operate these systems.

B.3 Aims of a property protection and business continuity risk assessment

NOTE Further advice and guidance can be obtained from the Fire Protection Association publication Design guide for the fire protection of building: Essential principles [42].

One aim of a property protection and business continuity risk assessment is to provide a link between the provisions for life safety and those for property protection and business continuity. In consequence the risk assessment should ensure that, as far as is reasonably practicable, the design of fire precautions and fire prevention management provides adequate control against fire development in order to protect against:

- a) property:
 - loss of contents;
 - damage to fabric and building services;
- b) business:
 - loss of dwellings and the social cost to the community;
 - need to provide rehousing;
 - loss of personal effects of the tenants;
 - loss of operational continuity for the business providing the housing.

B.4 Responsibilities

The responsibility for agreeing the level of fire precautions, and fire prevention management in relation to insurance, lies solely with the insurers or their agents and their client. The result of these discussions might result in a change of brief or increased fire precautions in the building. Consequently, discussions with the insurers should occur at an appropriate phase in the design and should allow for any contingency planning.

As part of the development of the brief, the responsibility for carrying out a property protection and business continuity risk assessment should be taken by one of the following:

- a) owner, occupier, operator, tenant or concessionaire, for self-assessment;
- b) suitably competent member of the design team;
- c) insurer's fire surveyor;
- d) risk manager/engineer;
- e) fire safety engineer.

The level of detail required should also be decided upon when allocating responsibility.

Any changes in the design should be discussed with the relevant authorities to ensure that there is no adverse impact on life safety.

NOTE There is frequently a life safety benefit as a result of a property protection measure. It might be possible to remove or simplify some life safety measures, in negotiation with the relevant authorities, when more stringent property protection measures are adopted.

B.5 Acceptable level of risk

The acceptable level of risk to property or business should be established at an appropriate stage in the design. This acceptable level of risk to property or business should be compared with the design criteria necessary for life safety. Any increases in performance standards required for property protection or business continuity should then be identified and incorporated in the design.

B.6 Risk assessment methodology

Initially, the appropriate type of risk assessment should be agreed.

NOTE 1 The risk assessment could range from a simple statement outlining the potential property and business losses which are acceptable to business managers and their insurers, through to a rigorous quantified analysis of probabilities and consequences of fire. As the design develops it is possible that the level of detail will change, especially for fitting out. This might lead to a change in the type of risk assessment required.

Whatever method is employed, the aims of the risk assessment should be met so that all concerned are aware of the potential risks and the required performance of the fire safety systems and equipment and management of fire safety.

NOTE 2 Whilst life safety takes priority in case of conflict, it is possible that improved property protection might replace a life safety feature without compromising overall safety.

The first stage in the process should be to assess the level of property protection and business continuity inherent in the design to meet the life safety provisions.

NOTE 3 This might be sufficient for many buildings equipped with automatic fire suppression systems, compartmentation, structural fire protection, and provisions to prevent external fire spread.

The second stage should be to identify any additional fire protection provisions. Care should be taken to identify any single points of failure that could have significant effects on business operations. An assessment should then be made as to whether additional protection or some form of redundancy is required, not only for key elements of the business but also for services supporting that key element.

B.7 Qualitative risk assessment

B.7.1 General

For many buildings, some form of qualitative risk assessment is appropriate. There are a number of hazard and risk assessment techniques. These should be discussed and the technique to be used agreed at an appropriate stage of the design.

When the aims or objectives for property protection and business continuity have been agreed, then a strategy for achieving those aims should be developed from the risk assessment, taking into account various methods to prevent fire occurring and developing.

NOTE 1 These methods are referred to here as controls on fire development and they take into account both fire prevention management and the design of fire precautions.

Controls on fire development should be assessed against the way the fire is likely to start and then grow.

NOTE 2 The growth of the fire and the actions of various controls on fire development can be assessed in a sequential order known as a time line. The following controls on fire development approximate to a time line for many fires:

- *fire prevention management: control of ignition sources and combustible material, training of staff and work procedures, maintenance and upkeep of fire safety systems;*
- *fire detection, fire alarm and first aid fire-fighting;*
- *smoke management;*
- *automatic fire suppression systems;*
- *compartmentation and structural fire protection;*
- *fire-fighting facilities (external and internal);*
- *external fire spread and building separation.*

As the fire grows, different controls on fire development dominate the probability that the fire is controlled in size or extinguished. The success or failure of each control mechanism should be taken into account in the risk assessment of potential damage to the property and business.

Any improvements in the management system should also be identified, together with contingency plans, as necessary.

B.7.2 Fire prevention management

The first barrier to property and business loss is the level of fire prevention management in the building. This is to ensure that ignition hazards are controlled or eliminated, that operations in the building are carried out appropriately and that combustible loads are subject to control and good housekeeping. It is also important to recognize that in domestic dwellings, the owner or occupier of that dwelling might have little expertise or understanding of the fire protection and prevention measures in their home. This lack of knowledge should be recognized and taken into account in determining the level of additional protection provided, both in terms of fire safety feature of the built environment and in advice given to occupants for managing the risk from fire in their dwellings.

B.7.3 Fire detection, fire alarm and first aid fire-fighting

If a fire occurs and grows then the first barrier to its development is by first aid fire-fighting. The usual advice to home owners is to refrain from first aid fire-fighting, leave the dwelling and call the fire and rescue service. In situations where staff are available, first aid fire-fighting might be appropriate, and any enhanced provision should be incorporated into the risk assessment.

B.7.4 Automatic fire suppression and smoke control

COMMENTARY ON B.7.4

If first aid fire-fighting is unsuccessful and the fire continues to grow then the next barrier to fire development is likely to come from any automatic fire suppression systems in the building. Automatic fire suppression or control systems can be in the form of AWFSS, fixed dry powder systems or gaseous fire suppression systems.

Smoke control systems can also contribute to property protection and business continuity. They can either be active or passive. Active smoke management systems can be turned on automatically via the fire detection and fire alarm system and take one or more of the following forms:

- *mechanical and natural smoke extract with appropriate means to allow make-up air. These are designed to either limit the extent of smoke spread and/or to reduce the build-up of heat in the compartment;*
- *pressurization systems to prevent the flow of smoke from one area to another by raising the pressure in the protected space;*
- *depressurization systems to prevent the flow of smoke from one area to another by lowering the pressure in the fire-affected space;*
- *directional fans designed to force smoke in one direction.*

With automatic fire suppression systems the fire can be assumed to be controlled or extinguished. Either way, a degree of smoke damage can be anticipated within the compartment or smoke reservoir depending on whether or not it is an active or passive smoke management system.

When assessing the adequacy of an automatic fire suppression or smoke control system, the design objectives of the system should be taken into account to ensure that it is sufficient for the aims of property protection and business continuity.

The potential for smoke damage should be assessed qualitatively for its impact on property and/or business. Care should be taken that any single points of failure that are likely to affect business operations are identified.

B.7.5 Compartmentation and structural fire resistance

COMMENTARY ON B.7.5

If there are no automatic fire suppression systems, or if for the purposes of an extreme event analysis it is decided to assume that the fire is not controlled by active means, then the next level of control on fire development is fire compartments and fire resistance to the structure. Compartmentation is often an important feature of residential building design.

Compartmentation is the provision of fixed horizontal and vertical barriers with designated fire resistance, including adequate fire-stopping; cavity barriers; dampers or seals; doors or shutters, all of which are commensurate with the barrier in which they are housed.

If a building is compartmented, smoke and heat damage can be assumed to occur throughout the compartment. There is also a risk that the compartmentation could be breached as a result of inadequate fire-stopping between floor slabs and the external façade, or by external fire spread via the façade.

When assessing the adequacy of the compartment and structural fire resistance, the design objectives should be taken into account to ensure that the fire resistance is sufficient for the aims of property protection or business continuity and day-to-day operation.

The potential for smoke and heat damage, and for breach of compartmentation, should be assessed. Care should be taken to identify single points of failure that are likely to affect business operations.

B.7.6 Fire-fighting facilities

COMMENTARY ON B.7.6

Although fire-fighting facilities are included here as the fifth control to fire development, they could be equally applicable from any moment that a fire is detected.

The speed of response to the fire and availability of fire-fighting provisions play an important role in limiting the potential damage to property.

The principal aim of these activities is life safety. For most buildings it is expected that these provisions will also be adequate for property protection.

The following two factors should be taken into account when assessing fire-fighting activities:

- provision for external fire-fighting;
- provision for internal fire-fighting.

Annex C (normative) C.1

Atria

General

NOTE This annex contains different design options for the inclusion of atria in residential buildings. The exemplars given cover buildings up to 18 m in height, incorporating both enclosed and unenclosed balconies.

The flowchart in Figure C.1 should be used to determine whether the atrium building falls within the scope of BS 9991 and, if it does, the flowchart should be used to determine a design solution.

Where specific reference is not made to a particular element of design and/or construction, such elements should be designed in accordance with the recommendations given elsewhere in this standard for non-atrium buildings.

Figure C.1 Occupancy category decision process

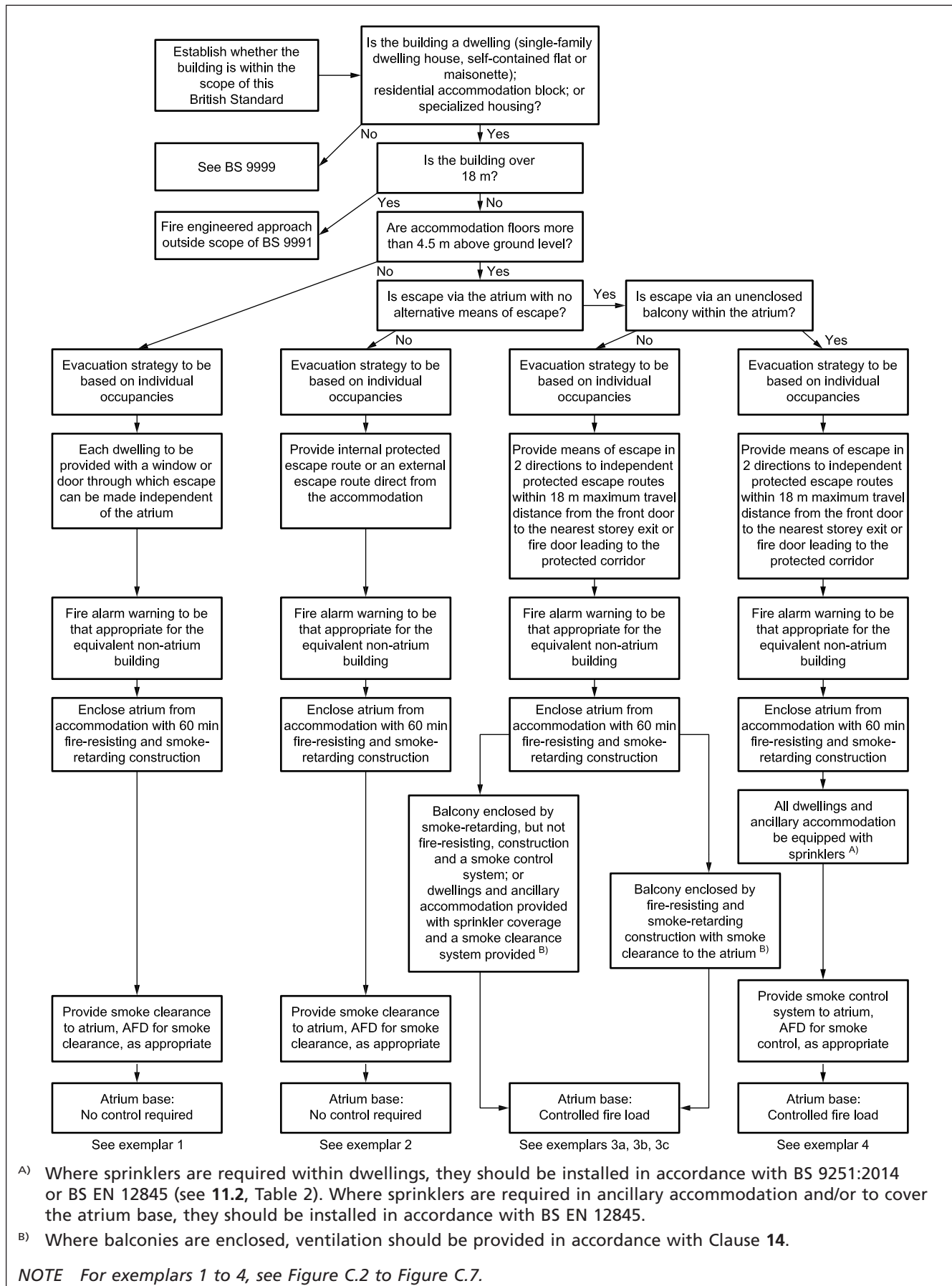
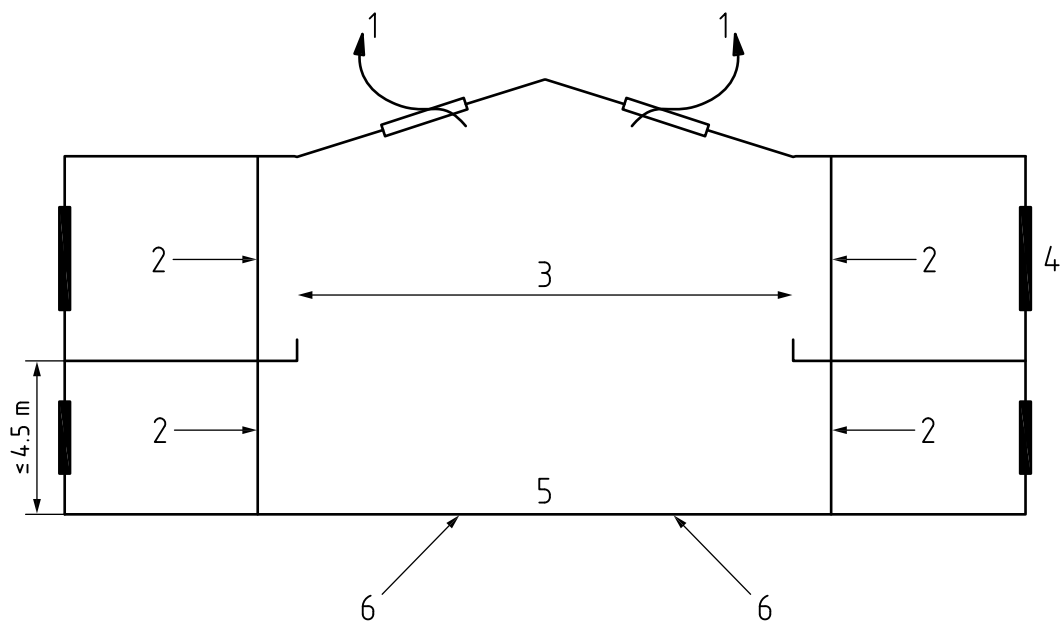

Figure C.2 Exemplar 1: Atrium base: no control required

**Key**

- 1 Smoke clearance system
- 2 Accommodation with 60 min fire-resisting (integrity and insulation) and smoke-retarding construction
- 3 Unenclosed balconies
- 4 External wall having a window or door through which escape can be made
- 5 Atrium base: no control required
- 6 Make-up air

The fire alarm and warning should be appropriate for the equivalent non-atrium building.

Figure C.3 Exemplar 2: Atrium base: no control required

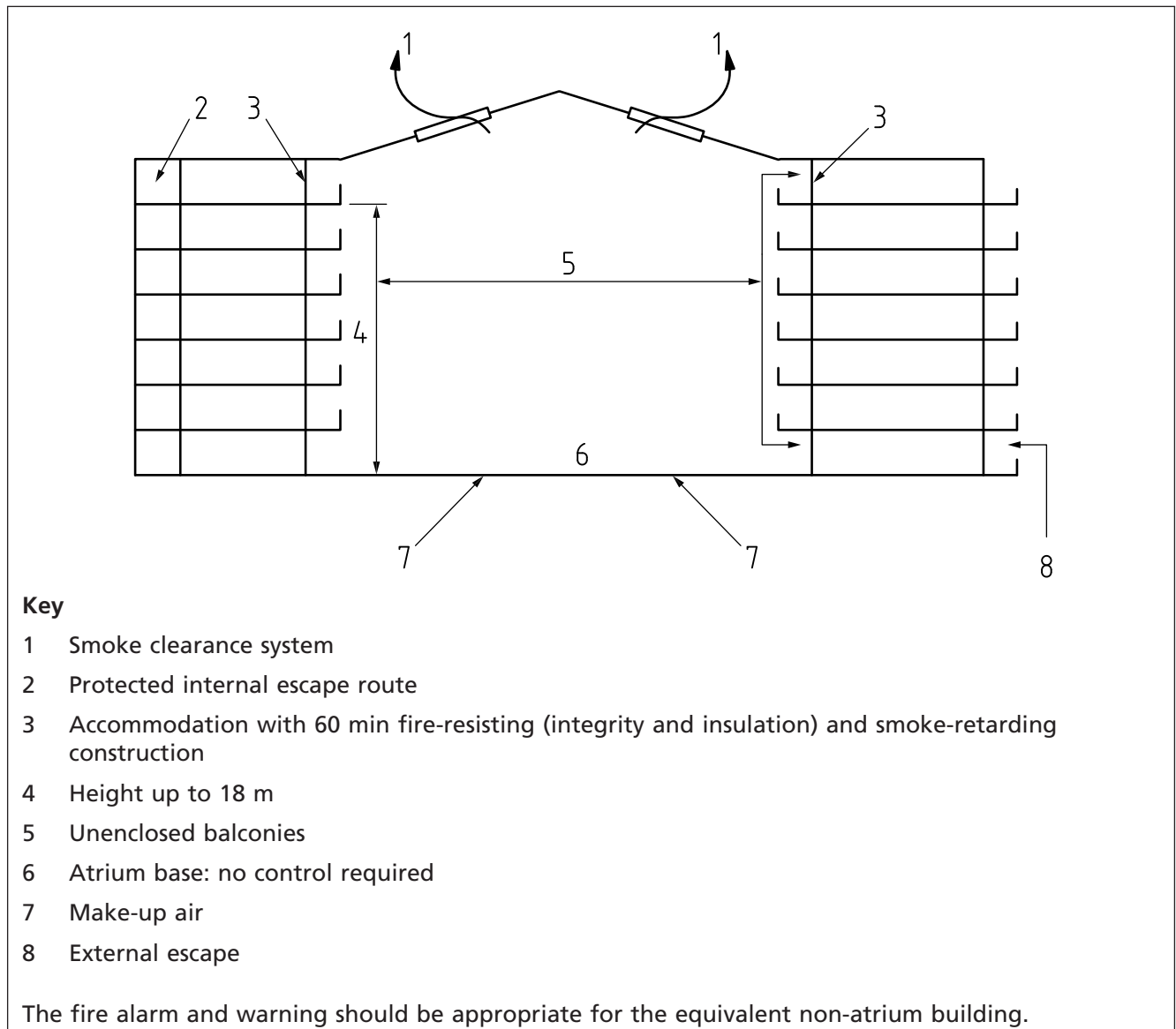
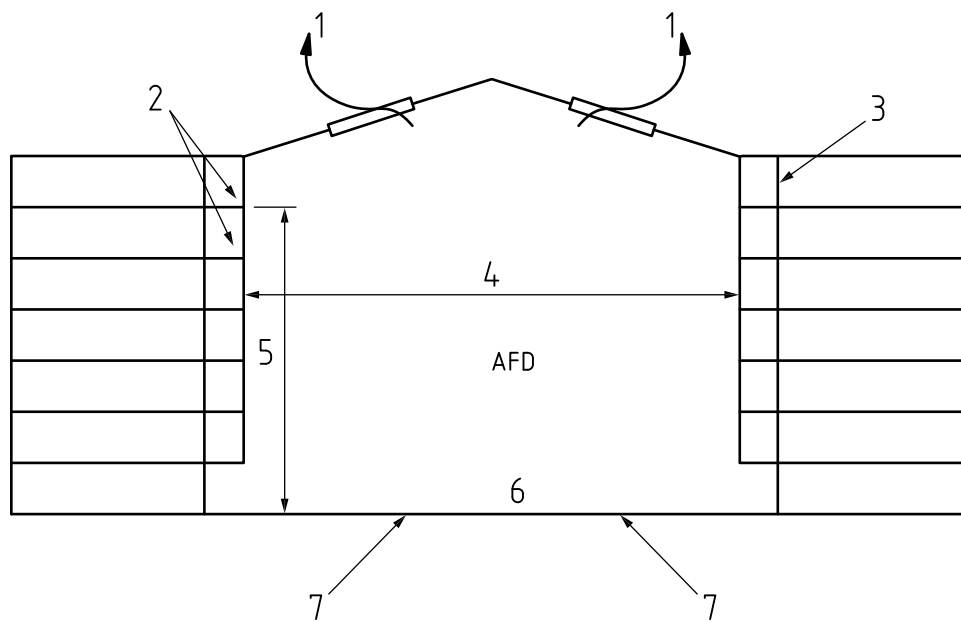

Figure C.4 Exemplar 3a: Atrium base: controlled fire load

**Key**

- 1 Smoke control system
- 2 Means of escape in two directions to independent, protected escape routes with a maximum travel distance in one direction of 18 m
- 3 Accommodation with 60 min fire-resisting (integrity and insulation) construction
- 4 Enclosed balconies with a smoke-retarding construction
- 5 Height up to 18 m
- 6 Atrium base: controlled fire load
- 7 Make-up air
- AFD Automatic fire detection appropriate to the smoke control system

The fire alarm and warning should be appropriate for the equivalent non-atrium building.

Figure C.5 Exemplar 3b: Atrium base: controlled fire load

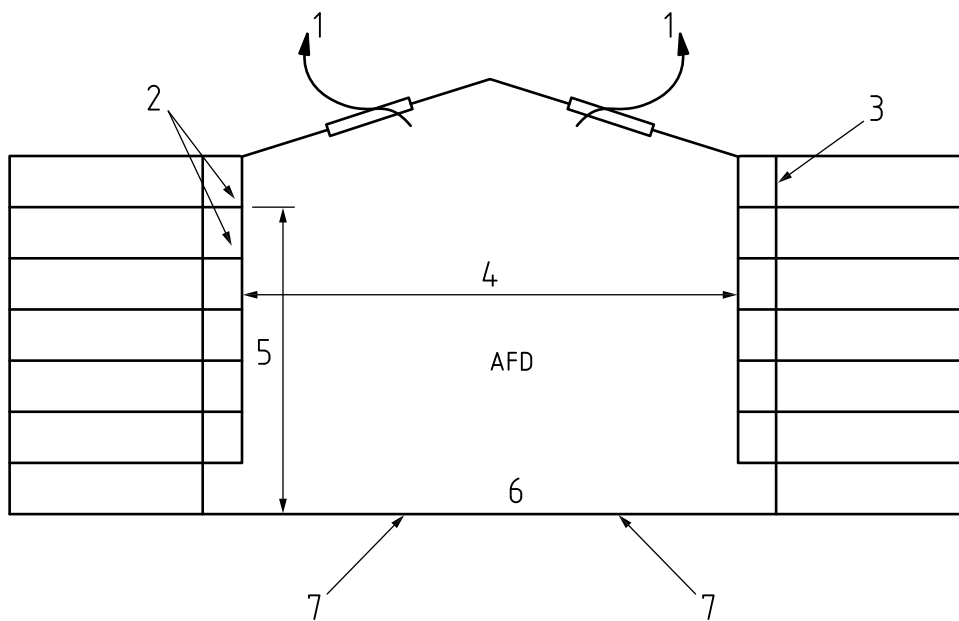
**Key**

- 1 Smoke clearance system
- 2 Means of escape in two directions to independent, protected escape routes with a maximum travel distance in one direction of 18 m
- 3 Accommodation with 60 min fire-resisting (integrity and insulation) construction
- 4 Enclosed balconies with fire-resisting and smoke-retarding construction
- 5 Height up to 18 m
- 6 Atrium base: controlled fire load
- 7 Make-up air
- AFD Automatic fire detection appropriate to the smoke control system

The fire alarm and warning should be appropriate for the equivalent non-atrium building.

Figure C.6 Exemplar 3c: Atrium base: controlled fire load

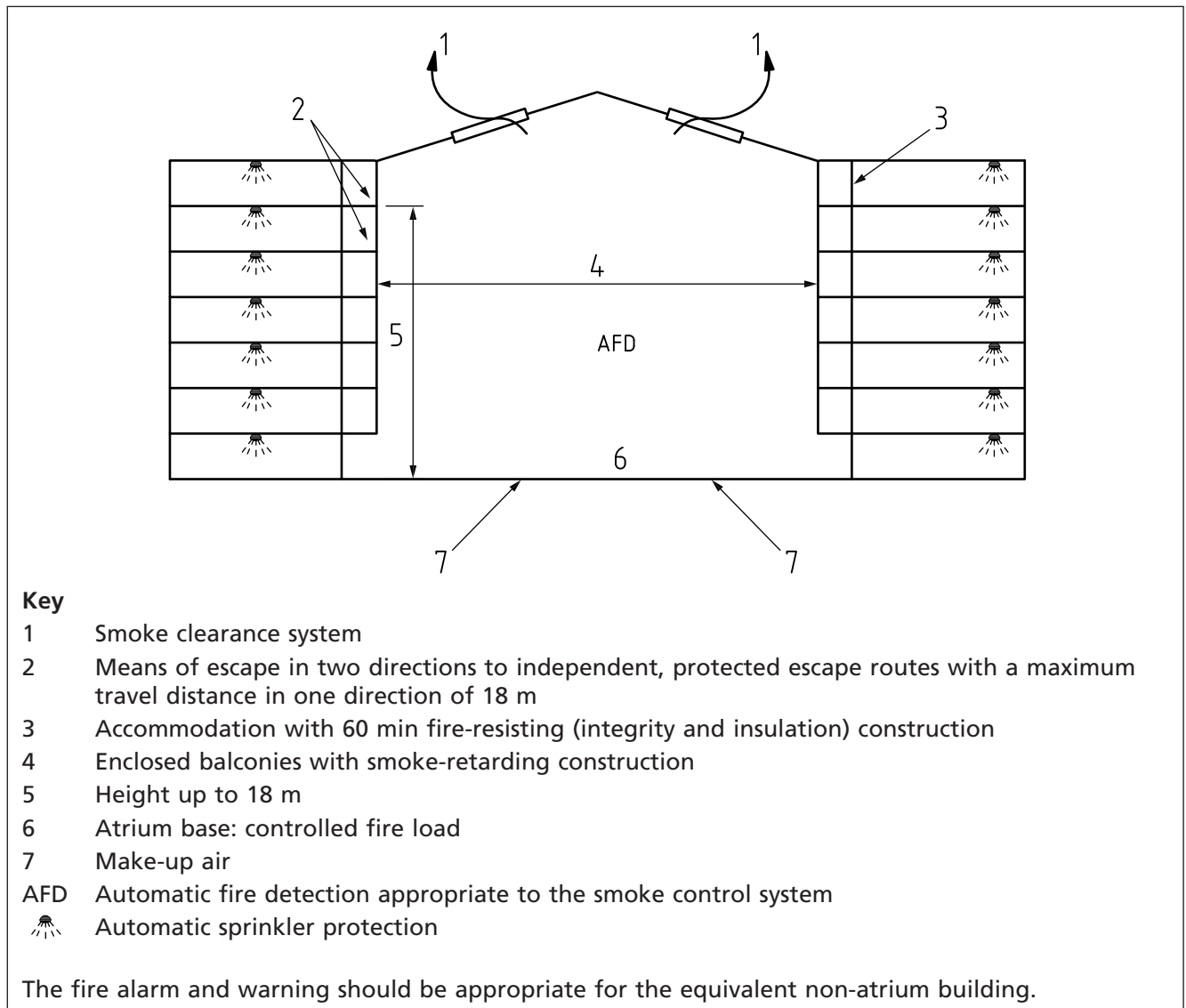
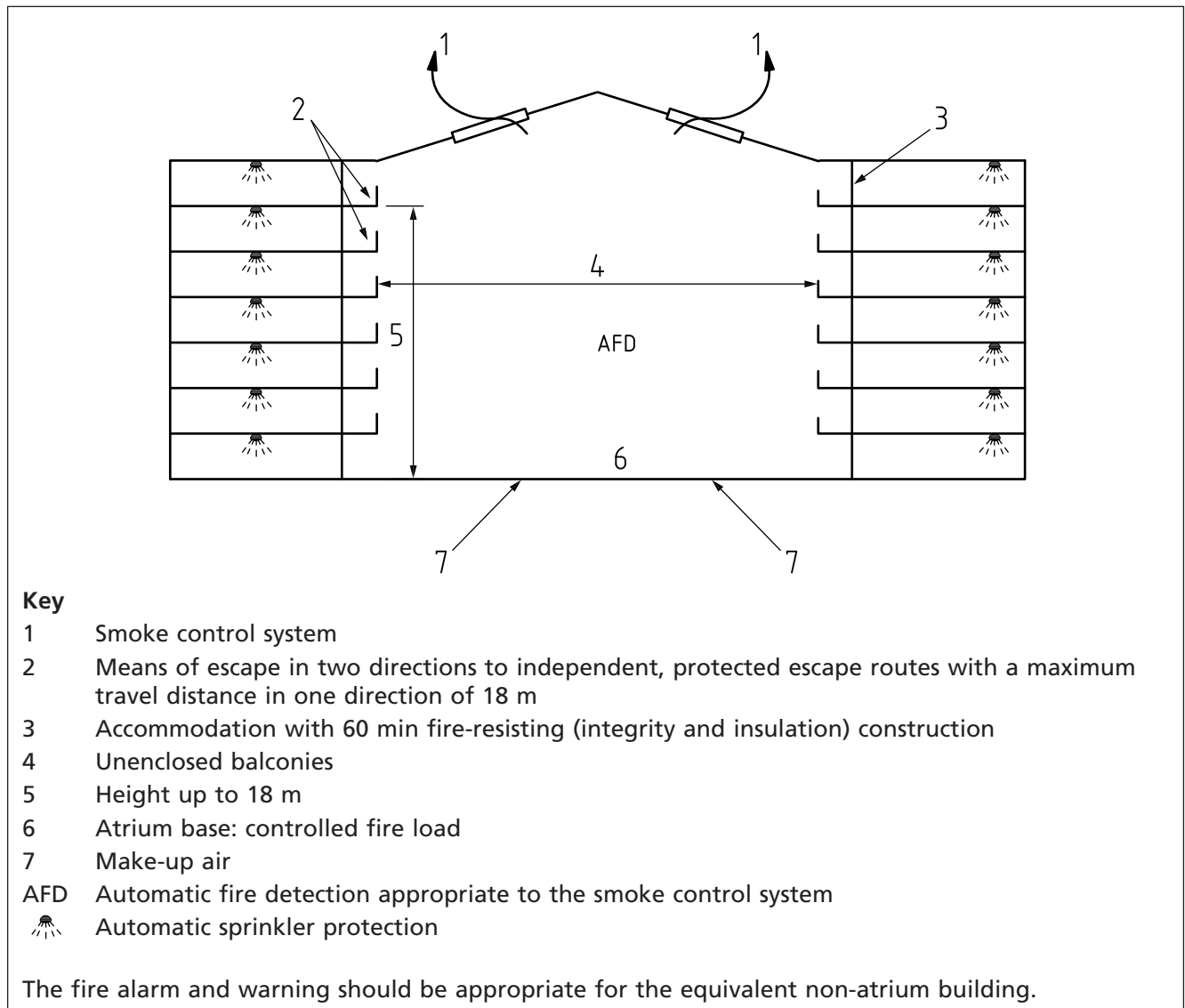

Figure C.7 Exemplar 4: Atrium base: controlled fire load



C.2 Means of escape

COMMENTARY ON C.2

The inclusion of active and passive fire and smoke control systems within an atrium is intended to ensure that the means of escape provided remains available to occupants throughout the evacuation of the building under fire conditions.

As a high degree of compartmentation is provided and therefore there is a low probability of fire spread beyond the dwelling of origin, it is unlikely that simultaneous evacuation will be necessary (see A.1 regarding stay put strategy). However, there might be some occasions where operational conditions are such that the fire and rescue service decide to evacuate the building. In these situations the occupants of the building might need to use the escape route; this might be while fire-fighting is in progress. As such, the recommendations in this standard for the protection of common escape routes and stairs are designed to ensure they remain available for use over an extended period.

It is essential, therefore, that the provision of means of escape follows established guidance, appropriate to the risk concerned, other than where specifically allowed for within this guidance.

When evacuating a building the occupants have a natural tendency to leave via the same route by which they entered. In planning for escape it is normally desirable that the escape routes coincide with circulation routes. However, in a building containing an atrium this is not always feasible and might not be desirable if it requires travel close to the edge of an open atrium.

Occupants of a building generally need to have alternative directions of escape, and the circumstances where a single direction of travel is acceptable are limited. This principle, and others such as maximum distances of travel, apply equally to a building containing an atrium as to one that does not. In circumstances where the atrium is not separated from the accommodation by fire-resisting construction, it is necessary to treat escape within and from the atrium, and escape from the associated areas, as an entity. It is particularly important to take into account the effect that the atrium might have on escape from upper storeys open to the atrium in view of the potential for a fire in the atrium to affect those storeys.

C.2.1 Balcony escape

COMMENTARY ON C.2.1

Escape via a balcony within the atrium space is acceptable without the need for an alternative protected escape route away from the atrium, provided that the balcony is protected from the effects of heat and smoke. Where there is an alternative protected escape route from the accommodation, these restrictions need not apply and open balcony escape routes are acceptable (see Figure C.2, exemplar 1 and Figure C.3, exemplar 2).

Where the means of escape is via a balcony within the atrium (i.e. where no alternative route from the accommodation is available), it should be in accordance with one of the following options.

a) Option 1:

- 1) the balcony should be enclosed with fire-resisting and smoke-retarding construction that conforms to the same specifications to that of the atria; and
- 2) a smoke clearance system should be provided from the atrium in accordance with C.6 and Figure C.5, exemplar 3b);

- b) **Option 2:**
- 1) the balcony should be enclosed by smoke-retarding but not fire-resisting construction; and
 - 2) a smoke control system should be provided from the atrium in accordance with C.3 and Figure C.4, exemplar 3a);
- c) **Option 3:**
- 1) the balcony should be enclosed by smoke-retarding but not fire-resisting construction;
 - 2) all dwellings should be provided with a sprinkler system in accordance with either BS 9251:2014 or BS EN 12845 (see 11.2, Table 2);
 - 3) all ancillary accommodation and atrium bases should be provided with a sprinkler system in accordance with BS EN 12845; and
 - 4) a smoke clearance system should be provided from the atrium in accordance with C.6 and Figure C.6, exemplar 3c).

Where the means of escape from the balcony is not separated from the atrium, a smoke control system should be provided in the atrium in accordance with C.6, all dwellings should be provided with a sprinkler system in accordance with BS 9251:2014 (see 11.2, Table 2 and Figure C.7, exemplar 4), and ancillary accommodation should be provided with a sprinkler system in accordance with BS EN 12845.

Escape within the atrium should be available in at least two directions with the travel distance within the atrium to the nearest storey exit not exceeding 18 m.

In all cases the atrium base should only contain a controlled fire load.

C.2.2 Fire alarm and detection system

Fire detection and alarm systems should meet the recommendations given in Section 3, as appropriate for the equivalent non-atrium building.

C.3 Prevention of fire and smoke spread in atria

COMMENTARY ON C.3

Recommendations and guidance are provided in this annex on various methods to prevent the flow of hot gases and flames from a fire in an associated dwelling into the atrium and subsequently having a possible effect on other dwellings.

Various strategies might be acceptable to achieve this, including:

- a) *fire-resisting and smoke-retarding construction between the atrium and the associated dwelling in conjunction with a smoke clearance system from the atrium;*
- b) *fire-resisting construction between the atrium and the associated dwelling in conjunction with a smoke control system in the atrium;*
- c) *fire-resisting construction between the atrium and the associated dwelling in conjunction with sprinkler protection to the dwelling and a smoke clearance system from the atrium.*

C.3.1 Fire-resisting construction

Where the accommodation needs to be separated from the atrium by a fire-resisting construction, then either side of the construction should be capable of meeting the integrity criterion specified in BS 476-22 for a period of not less than the appropriate period in Table 4 or Table 5, or the classification specified in the relevant part of BS EN 13501, unless otherwise recommended elsewhere in this standard.

C.3.2 Smoke-retarding construction

COMMENTARY ON C.3.2

It is not always necessary to enclose the atrium with fire-resisting construction. A smoke-retarding enclosure might, however, be needed to prevent the early ingress of smoke to those levels that are not directly affected by fire. Some forms of construction which are fire-resisting (e.g. traditional roller shutters) would not be sufficiently impervious to smoke to be considered as smoke-retarding.

Where smoke curtains are used, they should be in accordance with BS EN 12101-1.

In the absence of an appropriate method of test and performance criteria, such construction should not contain unsealed joints and permanently open, or openable, areas. Joints between such construction and any abutting element should be tight and preferably sealed with a filler conforming to BS EN 1366-3 or BS EN 1366-4 (e.g. plaster), a mastic, or a flexible strip (e.g. neoprene), as appropriate.

Any doors in an atrium, when tested in accordance with BS 476-31.1 with the threshold taped, and subjected to a pressure of 25 Pa, should have a leakage rate not exceeding 3 m³/h/m.

C.3.3 Enclosure

The enclosure of an atrium by imperforate construction (such as a glazed screen) can significantly reduce the probability of smoke damage to storeys removed from the fire. If the fire grows large, however, the temperature build-up within the atrium is likely to lead to failure of non-fire-resisting glazed elements, and smoke and flames can spread between storeys. If a fire continues to develop unchecked, the build-up of heat is likely to lead eventually to the failure of non-fire-resisting glazing systems used for the atrium enclosure. Therefore, to achieve an additional level of protection the provision of a fire-resisting enclosure to the atrium can be beneficial.

C.3.4 Connection of an atrium to below-ground storeys

There is essentially little difference in the potential for fire and smoke spread between an atrium penetrating below ground level and an atrium that is wholly above ground, and it is not necessary to separate the below-ground sections of an atrium and its associated floor areas from the upper storeys by means of fire-resisting construction. No specific recommendations are made for atria connecting with below-ground storeys, but it should be ensured that protected escape routes and fire-fighting provisions are in accordance with the recommendations for the equivalent non-atrium building.

C.4 Glazing

C.4.1 General recommendations for overhead glazing

Overhead glazing should be designed to minimize the risk of injury due to falling glass.

NOTE 1 This generally requires the use of polyvinylbutyral (pvb) laminated safety glass on the inner pane facing into the atrium space. Relevant guidance on the limitations of other glass types is given in BS 5516-2.

Up to a height of 5 m above floor level, glass should consist of:

- a) single glazing: toughened glass, heat-soaked toughened glass, pvb laminate safety glass, or Georgian wired glass; or

NOTE 2 Georgian wire glass contains a wire mesh within the body of the glass.

- b) insulating glazed units: the lower pane should be one of the above types. If the lower pane is either toughened or heat soaked toughened glass then the upper pane of the unit should also be one of the glass types given above.

At a height of between 5 m and 13 m above floor level, glass should consist of:

- 1) single glazing: Georgian wired glass or a glazing including pvb laminated safety glass as the outer layer. Heat soaked toughened glass may be used provided that the glass thickness is not more than 6 mm with a maximum pane size of 3 m²;
- 2) insulating glazed units: lower pane in accordance with 1) above. Where the lower pane is toughened glass then the upper pane should also be in accordance with 1) above.

At a height of more than 13 m above floor level, glass should consist of single glazing and the lower pane of insulating glass units: either Georgian wired glass or a glazing including pvb laminated safety glass as the inner pane.

C.4.2 Fire protection of glazed walls and the atrium roof

Glazed atrium walls and the atrium roof should meet the following recommendations.

- a) If one or more of the sides of the atrium form a vertical escape and access stair then the vertical glazing either side of the corner, for a distance of at least 3 m on both sides, should be a minimum of 30 min insulation and integrity for the full height of the atrium.
- b) The roof glazing should be part of a classified minimum 30 min integrity fire-resisting glazed system combined with a smoke-retarding construction.
- c) Any façade glazing outside and above the atrium should be part of a fire-resisting glazed system for a distance of at least two floors above the atrium roof, and having a minimum of 30 min insulation with integrity.

C.5 Load-bearing elements

The anticipated fire load (per m² of floor area) in a building incorporating an atrium would normally be no greater than in the equivalent non-atrium building.

Load-bearing elements of structure that are fire-resisting should therefore be of an equal level of fire resistance as those appropriate for the equivalent non-atrium building.

C.6 Smoke control and controlling the fire load on the atrium base

COMMENTARY ON C.6

Smoke control systems are designed to move or control the smoke and fire effluent in a predetermined manner in order to minimize the threat to life. Smoke control can be achieved in a number of different ways, such as through a smoke clearance system which assists fire-fighters in removing smoke from the building in the aftermath of a fire.

For general guidance on smoke control systems, see Annex A.

C.6.1 General

Smoke control systems should:

- a) maintain a clear layer of not less than 3 m above the top open-occupied storey, or 2.5 m above the floor of fire origin; and
- b) prevent the smoke layer temperature from exceeding 200 °C.

Where the design of the smoke control system allows the layer of smoke to descend below closed storeys, smoke should be prevented from leaking into these floors or, where applicable, the smoke control system design should ensure by dilution that the optical density per metre does not exceed 0.1 at all points on the top storey open to the atrium.

NOTE This measure is intended to ensure that the visibility on the open storeys does not become lower than the accepted 8 m to 10 m range which is deemed adequate for safe use of the escape routes.

C.6.2 Make-up air

It is essential that any smoky gases exhausted from the atrium are replaced by clean, fresh air. This replacement air should enter below any buoyant smoke layer to avoid immediate mixing with smoke, and to allow the best conditions for the use of escape routes and for fire-fighting.

C.6.3 Calculation procedures

Designers should establish that the calculation procedures used are relevant to the circumstances in which they are intended to be used. The procedures and calculations should be fully documented.

NOTE Guidance on calculation procedures for the design of smoke and heat control systems is given in a number of documents, e.g. BS 7346-4 and BS 7346-5, BRE Report 368 [17] and CIBSE Guide E [45].

C.6.4 Interaction with other systems

HVAC ductwork used in conjunction with a smoke control system presents a risk as inlet air and exhaust air can spread smoke and fire within the atrium building. This should be taken into account when determining fire protection measures, integrity of construction, ventilation controls, and routing of ductwork used for smoke and heat control systems.

C.6.5 Post-fire suppression ventilation

Smoke and heat from a building might need to be released after the fire has been suppressed by the fire and rescue service. Ventilation for this purpose is usually obtained by opening windows to provide cross-ventilation and smoke clearance. In a building with an atrium, the spread of smoke to a number of storeys can make it more difficult to open windows on every storey affected by smoke. In such circumstances, a mechanical or natural ventilating system capable of clearing the smoke from the atrium and the affected floor area should be provided.

Where a smoke control system is provided for means of escape purposes, it is not generally necessary to provide additional facilities specifically for the fire and rescue service. However, where such a system is not provided, smoke clearance facilities should be provided for operation by the fire and rescue service.

Stand-alone manual override facilities should be provided that allow the fire and rescue service to have direct control of the smoke control and normal ventilation systems within the building.

C.6.6 Natural smoke control for atria

A smoke control system operating on natural ventilation principles should be designed to remove residual smoke, taking due account of mixing effects, when relying solely on the thermal stack effect created by the buoyancy of the smoke and on the areas of openings provided.

NOTE A separate low level inlet is not always required. Inlet air can be provided by fire-fighters opening windows and doors.

Natural smoke clearance for atria should meet the following recommendations.

- a) Natural exhaust vents should be provided in the atrium roof. The total area of vents should be not less than 10% of the maximum plan area of the atrium.
- b) Vents should be located in such a way that ensures adequate coverage and cross-ventilation of the total atrium.
- c) Vents and associated controls should conform to BS EN 12101-2.

C.6.7 Mechanical smoke ventilation for atria

A mechanical smoke ventilation system should be provided having a low-level inlet within the atrium to provide replacement air changes every hour based upon the total volume of the atrium including the largest floor open to it. The mechanical smoke ventilation system should provide:

- a) four air changes per hour in sprinklered buildings where the atrium base has a controlled fire load;
- b) six air changes per hour in unsprinklered buildings.

C.6.8 Automatic control

Smoke control systems should be actuated by means of smoke detection in the common access space to flats.

C.6.9 Ventilation and smoke controls for the fire and rescue service

In order to assist the fire and rescue service in rescue, fire-fighting and clearance of smoke after the fire has been extinguished, it has become normal practice to provide switches at suitable locations by which fire and rescue service or other authorized personnel can override the operation of smoke exhaust fans and ventilators and alter the configuration of the normal air handling system. An assessment should be made as to whether such switches are required and, if required, where they should be located.

NOTE It might be advisable to seek the advice of the fire and rescue service regarding designing ventilation and smoke controls.

C.6.10 Controlling fire load on the atrium base

Where it is necessary to control the fire load within the atrium, the following recommendations should be met.

- a) If the total weight of combustibles on the atrium base exceeds 160 kg, the materials should be confined to isolated islands, each island containing a maximum of 160 kg of combustible material, covering a maximum floor area of 10 m², and being separated from other areas of combustible materials by a distance of at least 4 m (except where those areas are protected by a sprinkler system; see C.6.11).
- b) When tested in accordance with BS 476-7, all wall and ceiling linings should have at least a Class 1 surface spread of flame.

- c) When tested in accordance with BS 5852, all upholstered furniture should resist ignition from the smouldering source and the flaming source.
NOTE Attention is drawn to the provisions of the Furniture and Furnishings (Fire) (Safety) Regulations 2010 [46] in respect of filling materials.
- d) All textiles (drapes and curtains) should conform to BS 5867-2:2008.
- e) Where an automatic fire suppression system is provided, the fire load should be assumed to be controlled.

C.6.11 Sprinkler protection to the atrium base

Where sprinkler protection is provided to an atrium base, the objective is to limit the heat output of the fire to 2.5 MW convective heat flux. In atria, the effectiveness of sprinklers diminishes with an increase in height above the atrium base. This should be taken into account in their design and installation in order to ensure that they are correctly placed to be capable of achieving control of a fire. Sprinkler systems should be installed in accordance with BS EN 12845.

Annex D (normative)

Private balconies (open or enclosed) and communal roof gardens

D.1 General

All balconies should be guarded with a protective barrier conforming to BS 6180.

An open balcony is one that could reasonably be assumed to not become smoke-logged in a flat fire situation. At least 50% of the vertical section should be open and the area of opening should be uniformly spread around the surface.

D.2 Private balconies for the use of only one dwelling

No store (unless provided within a 30 min enclosure) or other fire risk should be erected externally on a balcony. Balconies no more than 4.5 m above ground level should be in accordance with 5.1c)3).

NOTE It is important to ensure that there is sufficient space to bring in and safely erect a suitable ladder.

Enclosed balconies should be treated as inner rooms.

Where balconies are enclosed and are contiguous with enclosed balconies to other flats, the fire resistance of the balcony structure and the compartmentation between balconies should be the same as the fire resistance required for the building.

D.3 Private balconies more than 4.5 m above ground level

Balconies more than 4.5 m above the ground level should meet the following recommendations.

- a) The escape route from the balcony should not pass through more than one access room.
- b) The interior of the access room should be clearly visible from all parts of the balcony unless provided by a fire detection and alarm system in accordance with BS 5839-6:2013.

- c) Any cooking risk in the access room should be enclosed with fire-resisting construction unless:
 - 1) the open cooking risk is remote from the balcony and positioned in such a way that it does not prejudice the escape route through the access room; and
 - 2) a fire detection and fire alarm system in accordance with BS 5839-6:2013 is provided to the access room with an alarm system on the balcony.
- d) Where the travel distance from the balcony access door to the furthest point on the balcony exceeds 7.5 m, it should be provided with an alternative escape route without going via the same access room, or the access room should be provided with automatic smoke detection.

D.4 Communal roof gardens, terraces and balconies

Roof spaces, terraces or balconies (used as a common amenity) having a travel distance exceeding 45 m should have an alternative escape route provided in accordance with Figure 2, Figure 3, Figure 4, Figure 12 or Figure 15. Where alternative escape is provided, roof space may be of any dimension.

The staircase leading to or from the roof garden, terrace or balcony should be protected from all floors (excluding an open roof area) in accordance with 14.1.2 for small buildings, or with 14.1.3 for buildings exceeding 11 m in height.

Where a roof garden is fully or partially enclosed, it should be treated as a floor for means of escape and the same protection should be provided to the staircase.

The lift serving any roof space, terrace or balcony should be in accordance with 8.4 and 24.1.5.

Where it is necessary to provide an alternative escape to a common amenity due to travel distances or enclosure and access to the common amenity is via a lift, provisions should be made as necessary for the safe and convenient use of the alternative escape by any persons with mobility impairments.

D.5 Communal roof gardens, terraces and balconies in specialized housing

The size and design of all balconies and roof terraces used in specialized housing should take into account the need for access and egress, whether assisted or unassisted.

D.6 Communal roof gardens and other open spaces

Communal roof gardens and other open spaces should meet the following recommendations.

- a) Access to communal roof gardens and similar places should be from a protected stairway enclosure or a protected ventilated lobby/corridor.
- b) Where the roof garden is open to the air, there should be no limit on the travel distance on the roof garden.
- c) Where the roof garden is enclosed:
 - 1) it should be separated from the approach stairs or lobby/corridor by a protected lobby; and
 - 2) travel distances within the roof garden space should be limited to 18 m where there is only a single direction of escape; or

- 3) travel distances within the roof garden space should be limited to 45 m where escape is possible in more than one direction.
- d) An alarm, audible throughout the roof garden, should be sounded upon activation of any fire detection system in the stairs or lobby/corridor access space.

Annex E
(informative)
E.1

Management of additional needs and disabilities

General

Building/estate managers need to make every effort to ensure that all residents and regular users are aware of the fire safety arrangements for the building and that they understand the actions they are to take in a fire emergency. Easy-read notices with appropriate symbols or pictures can help to communicate the key points to the majority, but in some cases providing information in alternative formats or through an interpreter or translator might be beneficial.

Information for disabled people needs to be noted in fire action notices and in the fire management plan. Assumptions cannot be made about the willingness of individuals to remain in their flats even where a stay put strategy is in place. It is also possible that some residents will not be inside their own dwelling at the time a fire occurs; they might for example be in the process of using lifts or stairs to reach their home, visiting a neighbour or in a common area such as a terrace or communal garden, in which case returning to their flat might not be appropriate or possible.

A duty of care is also owed to non-residents who might enter a building using a lift and then find themselves having to use the stairs to evacuate if the alarm sounds. Whilst in a stay put arrangement many residents and their guests are likely to stay in the relative safety of their own flat, account also needs to be taken of other people who might be on the premises but not be visiting any particular resident. This could, for example, apply to any supplier working in the common areas, or postal workers delivering goods to residents, such as home shopping, parcels, etc. Some of these individuals could have hidden disabilities such as heart or respiratory conditions which would make ambulant escape from a high-rise building difficult or impossible, or might be unable to hear or interpret the need for evacuation due to a hearing or cognitive impairment.

The UK has an ageing society, with increasing levels of independence into later years, and there are therefore many people living in standard residential accommodation who have a range of impairments which could affect their ability to evacuate or follow procedures.

Fire safety management needs to take into account the full range of people who might use the premises, paying particular attention to the needs of disabled people with permanent or temporary impairment.

Subclauses E.2 to E.8 do not give an exhaustive list but are indicative of the range of potential factors that need to be taken into account.

E.2 People with mobility impairments

Assumptions cannot be made about the abilities of wheelchair users. It can be helpful to produce a personal emergency evacuation plan (PEEP) to explore the level of need and what they are to do in the event of a fire in their own home or one nearby. If direct escape to a place of ultimate safety is not possible, horizontal escape to another fire compartment can be explored.

Many people other than wheelchair users are considered to have mobility impairments but are able to walk. This is often described as an ambulant disability. They might be able to use stairs but might not be able to reach a place of ultimate safety in the normal movement times or without some degree of discomfort. This can include people with other physical conditions affecting their mobility, such as respiratory or heart conditions. Fitting extra handrails and step edge markings can be particularly beneficial.

E.3 People with cognitive and learning impairments

This includes people with dyslexia, autism and dysphasia, as well as people with mild to severe learning difficulties. Some people might have problems comprehending what is happening and might not have a good perception of the risk from fire. They might have difficulties in orientation and be reluctant to take an unknown route to leave a building. Good escape route design, orientation information and clear notices can help.

E.4 People with a hearing impairment

The needs of people with hearing impairments need to be taken into account in the design of fire alarm systems and evacuation management plans, and the potential for some residents to link in their personal warning devices to the fire safety alerting system. Some people with hearing impairments have associated balance conditions which can also affect their ability to move swiftly.

E.5 People with a vision impairment

Many people with vision impairments have some sight and are able to use this during an escape to make their own way out of a building, especially when following others. Escape routes can, however, be improved by the use of good signage and features such as orientation clues, tactile information, audio signals, good visual contrast between key finishes such as floors and walls, and step edge marking. Appropriate tactile information can be of use to people with no residual vision.

E.6 Assistance dogs

Some people with sight, hearing or physical impairments rely on an assistance dog for day-to-day independence. Assistance dogs are expected to remain with their owners wherever possible, but account needs to be taken of the possibility of a person being separated from their assistance dog and how that would change their ability to evacuate. It also needs to be determined how the dog would be evacuated, as it is unrealistic to expect an owner to leave their dog behind when evacuating in a fire situation.

E.7 Additional needs not relating to a specific impairment

The following non-exhaustive list gives examples of people with additional needs that do not relate to a specific impairment:

- very elderly people;
- very young children;
- heavily pregnant women;
- people who are obese/bariatric;
- people under the influence of medication, alcohol or drugs;
- people recovering from surgery;
- people with temporary impairments such as sports injuries;
- people who do not understand English or who are illiterate.

E.8 Communicating the fire safety message

Important documents such as fire notices need to be easy for everyone to understand the contents without any ambiguity arising, including people with English as a second language, low literacy, cognitive impairments, visual impairments or learning disabilities. Appropriate fire notices would:

- be concise, preferably using bullet points;
- be written in Plain or Easy-Read English;
- be in large print, 16pt or above;
- be in sans serif type;
- have good contrast of text against the background of the notice;
- stand out clearly from the wall surfaces where they are located;
- be displayed at 1 500 mm above finished floor level;
- be supplemented with clear symbols.

Annex F
(informative)

Advice to occupiers of dwellings in residential buildings

F.1 General

This annex contains information regarding fire safety advice that can be given to occupiers of flats and other dwellings in residential buildings which are not single private dwellings. In general the same information applies to both occupiers of flats and occupiers of other domestic residential buildings. Where the information differs, the difference is highlighted in the text. The fire and rescue service can generally provide additional advice on fire safety if it is felt to be necessary. Examples of suitable fire instruction notices (see Clause 55) are given in F.10.

F.2 Smoke alarms

The longer a fire burns before it is discovered, the more likely it is to cause death or injury. A fire that starts smouldering at night is therefore very dangerous.

People are not always awoken by the smell of smoke. A fire involving certain furnishings can produce poisonous gases that prevent people from recovering consciousness. Even when people do wake up, their means of exit can be blocked by thick smoke.

Installing smoke alarms in a dwelling does not stop fires starting and does not put a fire out, but if properly installed and looked after they can give an early warning of fire and increase the chances of escape.

Guidance on the selection and installation of smoke alarms can be obtained from local fire and rescue services.

F.3 Ways in which fires can start

Fires in domestic buildings can start in many ways, including:

- careless use of matches, candles, cigarettes and pipes;
- careless use of cookers, especially leaving chip pans without watching them;
- drying and airing of clothes and other items that could burn near heaters (such as gas fires and electric radiant, storage and convector heaters);
- no fire guards to prevent objects from falling into an open fire;

- children playing with matches and cigarette lighters;
- old or faulty domestic appliances, including electric blankets;
- putting portable heaters close to furniture and curtains;
- not taking out the plugs from electrical appliances at night or when away from home, unless they are designed for continuous operation, e.g. refrigerators, video recorders, clocks;
- use of paraffin heaters;
- covering of storage and convector heaters thus preventing air from getting to them;
- irregular or poor servicing of heating appliances.

F.4 General fire safety advice

Figure F.1 shows an example of general fire safety advice that can be given to occupiers of dwellings in residential buildings.

F.5 Heating

Most dwellings, including flats, are provided with a fixed heating system. The risk of a fire occurring can be reduced if the fixed heating system is used rather than heaters, as all types of portable heaters can start a fire if they are not properly sited, used correctly and maintained in good working order.

The entrance lobby and corridor of a flat is the normal escape route in the event of a fire, so it is essential that portable radiant heaters are not used in these areas. It is not advisable to use paraffin heaters. Special care needs to be taken with portable bottle gas heaters, particularly when changing cylinders. The manufacturer's instructions for all portable heaters include guidance on where they are to be placed, how they are to be used and how they can be kept in safe working order.

F.6 Doors

Self-closing doors are provided in flats and other dwellings in residential buildings, to stop the spread of fire and smoke. It is most important that they are not wedged open and that the self-closing mechanism works correctly.

If self-closing doors do not close themselves, it is the responsibility of the occupants to ensure that the defect is reported to the porter, caretaker or landlord, or to the local housing authority.

It can help to prevent the spread of fire if occupants tightly close as many doors as possible before going to bed or when leaving the premises empty.

F.7 Abuse of fire-fighting equipment

Fire-fighting equipment (in the form of fire extinguishers, fire mains and outlets) and fire safety signs might be installed in flats and other residential buildings. Where such equipment is installed, it is the responsibility of all occupants to ensure that it is not interfered with, and that, if any item of equipment is found damaged, to report it immediately.

F.8 Access roads

It is important that fire and rescue service access roads to blocks of flats and other residential buildings are kept clear and unobstructed, to allow access by the fire and rescue service and other emergency vehicles at all times. It is the responsibility of all occupants to ensure that they do not park their cars in these roads or allow their visitors to do so, and if they see any vehicles parked there, to report them.

Figure F.1 General fire safety advice for occupiers of dwellings in residential buildings

Small fires are common, causing serious injuries and extensive damage to property and possessions. By following a few simple steps and maintaining a basic level of awareness you can considerably reduce the chances of fire in your home. The easiest and most effective way of protecting your home is by fitting at least one smoke alarm, and regularly making sure it works.

The following 13 tips will help keep your family and home safe:

1. Fit smoke alarms on each level in your home. Keep them free from dust and test them once a week. Consider buying a 10-year alarm; otherwise change the batteries in your alarm every year.
2. Make a fire action plan so that everyone in your home knows how to escape if there is a fire.
3. Keep the exits from your home clear so that people can escape if there is a fire.
4. Make sure that everyone in your home can easily find the keys for doors and windows.
5. Take extra care in the kitchen – accidents while cooking account for over half of fires in homes. Never leave young children alone in the kitchen.
6. Take extra care when cooking with hot oil. Consider buying a deep-fat fryer which is controlled by a thermostat (if you don't already have one).
7. Never leave lit candles in rooms that nobody is in or in rooms where children are on their own. Make sure candles are in secure holders on a surface that doesn't burn and are away from any materials that could burn.
8. Make sure cigarettes are stubbed out properly and are disposed of carefully, and never smoke in bed.
9. Get into the habit of closing doors at night. If you want to keep a child's bedroom door open, close the doors to the lounge and kitchen; it might help to save their life if there is a fire.
10. Don't overload electrical sockets. Remember, one plug for one socket.
11. Keep matches and lighters where children can't see or reach them.
12. Take special care when you're tired or when you've been drinking.
13. Don't leave the TV or other electrical appliances on standby as this could cause a fire. Always switch it off and unplug it when it is not in use.

If you or a member of your household has any difficulty seeing, hearing or moving about the home, you will need to take extra care to deal with the risk of a fire. Your local fire and rescue service will be able to assess how safe your home is and help to fit fire safety equipment such as smoke alarms.

High-rise flats are built to be fire-resisting, and most fires won't spread further than one or two rooms. Walls, ceilings and doors will hold back flames and smoke, so if there's a fire somewhere else in the building, you're usually safest staying in your flat unless you're affected by heat or smoke. You should plan how to escape if there is a fire in your home. It is likely that the flat will share common areas with other flats. The owner or occupiers of the flats will have the responsibility of making sure that the necessary fire precaution measures needed in these areas are installed. For example, there may be a fire alarm and the doors and fire-resisting features of the common areas will need to be maintained.

It is important that occupiers understand the fire precaution measures built into the common areas and that they ask the landlord to explain the safety plans for the premises and make sure that they are familiar with what they should do when a fire happens. If you cannot escape you will need to find a room where you can wait for assistance. This is particularly important if you have difficulty moving around or using stairs. It is advisable for your safe room to have a window that opens, and a phone.

F.9 Automatic water fire suppression systems (AWFSS)

These systems are activated by heat from the fire, and release water onto it. They are designed to prevent the fire growing, so that much less smoke and heat are produced and people have more time to escape. In many cases an AWFSS will put the fire out. Where an AWFSS is installed it is important that the sprinklers or watermist nozzles are not painted over, since this can slow their response to a fire. Concealed sprinklers hide the sprinkler using a cover plate, which falls away when the solder holding it in place melts. It is particularly important that this cover plate is not painted over.

F.10 Examples of fire instruction notices

The fire instruction notice provides instructions on fire precautions and actions to take in the event of a fire. This annex gives examples of fire instruction notices for a range of situations.

An example of a suitable fire instruction notice for flats is shown in Figure F.2.

An example of a suitable fire instruction notice for other residential buildings is shown in Figure F.3.

Figure F.2 Example of a fire instruction notice for use in flats

This building has been built in such a way as to protect the people in it if a fire breaks out. The important thing to remember is that if the fire starts in your home, it is up to you to make sure that you can get out of it.

AT ALL TIMES

- Make sure that the smoke alarms in your home are working.
- Do not store anything in your hall or corridor, especially anything that will burn easily.
- Use the fixed heating system fitted in your home. If this is not possible, only use a convector heater in your hall or corridor. Do not use any form of radiant heater there, especially one with either a flame (gas or paraffin) or a radiant element (electric bar fire).
- Do not store things in the cupboard(s) where your gas and electricity meters are fitted.
- Do not block access roads to the building.

IF A FIRE BREAKS OUT IN YOUR HOME

- If you are in the room where the fire is, leave straight away, together with anybody else, then close the door.
- Do not stay behind to try to put the fire out.
- Tell everybody else in your home about the fire and get everybody to leave. Close the front door and leave the building.
- Do not use the lift (unless it is a designated evacuation lift).
- Do not use a balcony unless it is part of the escape route from the building.
- CALL THE FIRE AND RESCUE SERVICE.

IF YOU SEE OR HEAR OF A FIRE IN ANOTHER PART OF THE BUILDING

- It will usually be safe for you to stay in your own home.
- You must leave your home if smoke or heat affects it. Close all doors and windows.

CALLING THE FIRE AND RESCUE SERVICE

The fire and rescue service should always be called to a fire, even if it only seems a small fire. This should be done straight away.

The way to call the fire and rescue service is by telephone as follows.

- 1) Dial 999.
- 2) When the operator answers, give the telephone number you are ringing from and ask for FIRE.
- 3) When the fire and rescue service reply, tell them clearly the address where the fire is.
- 4) Do not end the call until the fire and rescue service have repeated the address to you and you are sure they have got it right. The fire and rescue service cannot help if they do not have the full address.

Figure F.3 Example of a fire instruction notice for use in other residential buildings

If a fire starts in your home, it is up to you to make sure that you can get out of it. Do not wait until a fire happens. Read these instructions and find out the best way for you and your family to get out of your home and also out of the building if a fire started somewhere else. There may be more than one way out. If you and all the other people in the building follow these rules you will all be much safer and less likely to start a fire or be injured in one.

AT ALL TIMES

- Make sure that the smoke alarms in your home are working.
- Do not store anything in your hall or corridor, especially anything that will burn easily.
- Use the fixed heating system fitted in your home. If this is not possible, only use a convector heater in your hall or corridor. Do not use any form of radiant heater there, especially one with either a flame (gas or paraffin) or a radiant element (electric bar fire).
- Do not store things in the cupboard(s) where your gas and electricity meters are fitted.
- Do not block access roads to the building.

IF A FIRE BREAKS OUT IN YOUR HOME

- If you are in the room where the fire is, leave straight away, together with anybody else, then close the door.
- Do not stay behind to try to put the fire out.
- Tell everybody else in your home about the fire and get everybody to leave. Close the front door and leave the building.
- Do not use the lift (unless it is a designated evacuation lift).
- Do not use a balcony unless it is part of the escape route from the building.
- CALL THE FIRE AND RESCUE SERVICE.

CALLING THE FIRE AND RESCUE SERVICE

The fire and rescue service should always be called to a fire, even if it only seems a small fire. This should be done straight away.

The way to call the fire and rescue service is by telephone as follows.

- 1) Dial 999.
- 2) When the operator answers give the telephone number you are ringing from and ask for FIRE.
- 3) When the fire and rescue service reply tell them clearly the address where the fire is.
- 4) Do not end the call until the fire and rescue service have repeated the address to you and you are sure they have got it right. The fire and rescue service cannot help if they do not have the full address.

Bibliography

Standards publications

For dated references, only the edition cited applies. For undated references, the latest edition of the referenced document (including any amendments) applies.

BS 3632, *Residential park homes – Specification*

BS 5516-2, *Patent glazing and sloping glazing for buildings – Part 2: Code of practice for sloping glazing*

BS 6891, *Installation of low pressure gas pipework of up to 35 mm (R1 1/4) in domestic premises (2nd family gas) – Specification*

BS 7346 (all parts), *Components for smoke and heat control systems*

BS 7974, *Application of fire safety engineering principles to the design of buildings – Code of practice*

BS 8300, *Design of buildings and their approaches to meet the needs of disabled people – Code of practice*

BS 9266, *Design of accessible and adaptable general needs housing – Code of practice*

BS 25999 (all parts), *Business continuity management*

BS EN 1155, *Building hardware – Electrically powered hold-open devices for swing doors – Requirements and test methods*

BS EN 1991-1-2, *Eurocode 1 – Actions on structures – General actions – Actions on structures exposed to fire*

BS EN ISO 11925-2, *Reaction to fire tests – Ignitability of products subjected to direct impingement of flame – Single-flame source test*

BS EN ISO 14122-4, *Safety of machinery – Permanent means of access to machinery – Part 4: Fixed ladders*

DD ENV 1187:2002, *Test methods for external fire exposure to roofs*

PD 7974-5, *Application of fire safety engineering principles to the design of buildings – Part 5: Fire and rescue service intervention (Sub-system 5)*

PD 7974-6, *The application of fire safety engineering principles to fire safety design of buildings – Part 6: Human factors – Life safety strategies – Occupant evacuation, behaviour and condition (Sub-system 6)*

Other publications

[1] GREAT BRITAIN. Building Regulations 2010 and subsequent amendments. London: The Stationery Office.

[2] GREAT BRITAIN. Regulatory Reform (Fire Safety) Order 2005. London: The Stationery Office.

[3] GREAT BRITAIN. Building (Amendment) (Wales) Regulations 2014. London: The Stationery Office.

[4] SCOTLAND. Building (Scotland) Regulations 2004 and subsequent amendments. Edinburgh: The Stationery Office.

[5] GREAT BRITAIN. Building Regulations (Northern Ireland) 2012 and subsequent amendments. Belfast: The Stationery Office.

[6] SCOTLAND. Fire Safety (Scotland) Regulations 2006. Edinburgh: The Stationery Office.

- [7] NORTHERN IRELAND. Fire Safety Regulations (Northern Ireland) 2010. Belfast: The Stationery Office.
- [8] GREAT BRITAIN. Construction Products Regulations 2013. London: The Stationery Office.
- [9] HISTORIC SCOTLAND. *Conversion of traditional buildings*. Guide for Practitioners 6. Edinburgh: Historic Scotland, 2007.
- [10] HISTORIC SCOTLAND. *Fire safety management in traditional buildings*. Guide for Practitioners 7. Edinburgh: Historic Scotland, 2010.
- [11] LACORS. *Housing – Fire safety*. London: LACORS, 2008. ISBN 978 1 84049 638 3.
- [12] GREAT BRITAIN. Housing Act 2004. London: The Stationery Office.
- [13] GREAT BRITAIN. Equality Act 2010. London: The Stationery Office.
- [14] DEPARTMENT FOR COMMUNITIES AND LOCAL GOVERNMENT. *The Building Regulations 2010 – Approved Document B: Fire safety*. (Volumes 1 and 2.) 2006 ed. incorporating 2010 and 2013 amendments. London: National Building Specification (NBS), 2013.
- [15] SCOTTISH BUILDING STANDARDS AGENCY. *The Scottish Building Standards Technical Handbook – Domestic – Section 2: Fire*. Edinburgh: Scottish Government, 2013.
- [16] NORTHERN IRELAND DEPARTMENT OF FINANCE AND PERSONNEL. *The Building Regulations (NI) 2000 Technical Booklet E – Fire safety*. Belfast: The Stationery Office, 2005.
- [17] BUILDING RESEARCH ESTABLISHMENT. *Design methodologies for smoke and heat exhaust ventilation*. BR 368. Watford: BRE, 1999.
- [18] SMOKE CONTROL ASSOCIATION. *Guidance on smoke control to common escape routes in apartment buildings (flats and maisonettes)*. Reading: FETA, 2015.
- [19] GREAT BRITAIN. Building Regulations 2000. London: The Stationery Office.
- [20] BUILDING RESEARCH ESTABLISHMENT. *Increasing the fire resistance of existing timber floors*. DG 208. Watford: BRE, 1988.
- [21] BUILDING RESEARCH ESTABLISHMENT. *External fire spread: building separation and boundary distances*. BR 187. Watford: BRE, 1991.
- [22] BUILDING RESEARCH ESTABLISHMENT. *Fire safety of PTFE-based materials used in building*. BR 274. Watford: BRE, 1994.
- [23] GLASS AND GLAZING FEDERATION. *A guide to best practice in the specification and use of fire-resistant glazed systems*. Edition 3. London: GGF, 2011.
- [24] ASSOCIATION OF BUILDERS AND HARDWARE MANUFACTURERS. *Code of practice – Hardware essential to the optimum performance of fire-resisting timber doorsets*. Tamworth: ABHM, 1993.
- [25] LOSS PREVENTION COUNCIL. *LPC design guide for the fire protection of buildings*. London: Fire Protection Association, 2000.
- [26] DOOR AND HARDWARE FEDERATION. *Code of practice for fire-resisting metal doorsets*. CP 102. Tamworth: DHF, 2010.
- [27] DEPARTMENT FOR COMMUNITIES AND LOCAL GOVERNMENT. *The Building Regulations 2010 – Approved Document K: Protection from falling, collision and impact*. 2013 ed. for use in England. London: National Building Specification (NBS), 2013.

- [28] COMMUNITIES AND LOCAL GOVERNMENT. *Fire performance of escape stairs: BD 2569*. London: CLG, 2009.
- [29] BUILDING CONTROL ALLIANCE. *Use of timber stairs in residential buildings exceeding three storeys*. Guidance Note 19. BCA, 2014.
- [30] ASSOCIATION FOR SPECIALIST FIRE PROTECTION. *Fire resisting ductwork tested to BS 476 Part 24 (Blue Book)*. Second edition. Bordon: ASFP, 2007.
- [31] ASSOCIATION FOR SPECIALIST FIRE PROTECTION. *Volume 1: Fire dampers (European standards) – E (integrity) and ES (integrity and leakage) classified (Grey Book)*. Second edition. Bordon: ASFP, 2010.
- [32] GREAT BRITAIN. Gas Safety (Installation and Use) Regulations 1998. London: The Stationery Office.
- [33] INSTITUTION OF GAS ENGINEERS AND MANAGERS. *Recommendations on transmission and distribution practice – PE and steel gas services and service pipework*. IGE/TD/4 Edition 4 (1725). Loughborough: IGEM.
- [34] GREAT BRITAIN. Pipelines Safety Regulations 1996. London: HMSO.
- [35] INSTITUTION OF GAS ENGINEERS AND MANAGERS. *Gas in multi-occupancy dwellings*. IGEM/G/5. Loughborough: IGEM, 2012.
- [36] GREAT BRITAIN. Petroleum (Consolidation) Regulations 2014. London: The Stationery Office.
- [37] GREAT BRITAIN. Dangerous Substances and Explosive Atmospheres Regulations 2002. London: The Stationery Office.
- [38] GREAT BRITAIN. Construction (Design and Management) Regulations 2015. London: The Stationery Office.
- [39] NORTHERN IRELAND. Construction (Design and Management) Regulations (Northern Ireland) 2007. Belfast: The Stationery Office.
- [40] HEALTH AND SAFETY EXECUTIVE. *Fire safety in construction*. HSG 168. London: HSE Books, 2010.
- [41] CONSTRUCTION CONFEDERATION AND FIRE PROTECTION ASSOCIATION. *Fire prevention on construction sites – The joint code of practice on the protection from fire of construction sites and buildings undergoing renovation*. London: Construction Confederation and Fire Protection Association, 2009.
- [42] FIRE PROTECTION ASSOCIATION. *Design guide for the fire protection of buildings: Essential principles*. London: FPA, 2003.
- [43] COMMUNITIES AND LOCAL GOVERNMENT. *Arson control forum annual report*. London: CLG, 2006.
- [44] ARSON PREVENTION BUREAU. *How building design can reduce the threat from arson*. London: Arson Prevention Bureau, 1997.
- [45] CHARTERED INSTITUTION OF BUILDING SERVICES ENGINEERS. *Fire safety engineering: CIBSE Guide E*. London: CIBSE, 2010.
- [46] GREAT BRITAIN. Furniture and Furnishings (Fire) (Safety) Regulations 2010. London: The Stationery Office.

British Standards Institution (BSI)

BSI is the national body responsible for preparing British Standards and other standards-related publications, information and services.

BSI is incorporated by Royal Charter. British Standards and other standardization products are published by BSI Standards Limited.

About us

We bring together business, industry, government, consumers, innovators and others to shape their combined experience and expertise into standards-based solutions.

The knowledge embodied in our standards has been carefully assembled in a dependable format and refined through our open consultation process. Organizations of all sizes and across all sectors choose standards to help them achieve their goals.

Information on standards

We can provide you with the knowledge that your organization needs to succeed. Find out more about British Standards by visiting our website at bsigroup.com/standards or contacting our Customer Services team or Knowledge Centre.

Buying standards

You can buy and download PDF versions of BSI publications, including British and adopted European and international standards, through our website at bsigroup.com/shop, where hard copies can also be purchased.

If you need international and foreign standards from other Standards Development Organizations, hard copies can be ordered from our Customer Services team.

Subscriptions

Our range of subscription services are designed to make using standards easier for you. For further information on our subscription products go to bsigroup.com/subscriptions.

With **British Standards Online (BSOL)** you'll have instant access to over 55,000 British and adopted European and international standards from your desktop. It's available 24/7 and is refreshed daily so you'll always be up to date.

You can keep in touch with standards developments and receive substantial discounts on the purchase price of standards, both in single copy and subscription format, by becoming a **BSI Subscribing Member**.

PLUS is an updating service exclusive to BSI Subscribing Members. You will automatically receive the latest hard copy of your standards when they're revised or replaced.

To find out more about becoming a BSI Subscribing Member and the benefits of membership, please visit bsigroup.com/shop.

With a **Multi-User Network Licence (MUNL)** you are able to host standards publications on your intranet. Licences can cover as few or as many users as you wish. With updates supplied as soon as they're available, you can be sure your documentation is current. For further information, email bsmusales@bsigroup.com.

BSI Group Headquarters

389 Chiswick High Road London W4 4AL UK

Revisions

Our British Standards and other publications are updated by amendment or revision.

We continually improve the quality of our products and services to benefit your business. If you find an inaccuracy or ambiguity within a British Standard or other BSI publication please inform the Knowledge Centre.

Copyright

All the data, software and documentation set out in all British Standards and other BSI publications are the property of and copyrighted by BSI, or some person or entity that owns copyright in the information used (such as the international standardization bodies) and has formally licensed such information to BSI for commercial publication and use. Except as permitted under the Copyright, Designs and Patents Act 1988 no extract may be reproduced, stored in a retrieval system or transmitted in any form or by any means – electronic, photocopying, recording or otherwise – without prior written permission from BSI. Details and advice can be obtained from the Copyright & Licensing Department.

Useful Contacts:

Customer Services

Tel: +44 845 086 9001

Email (orders): orders@bsigroup.com

Email (enquiries): cservices@bsigroup.com

Subscriptions

Tel: +44 845 086 9001

Email: subscriptions@bsigroup.com

Knowledge Centre

Tel: +44 20 8996 7004

Email: knowledgecentre@bsigroup.com

Copyright & Licensing

Tel: +44 20 8996 7070

Email: copyright@bsigroup.com



...making excellence a habit.™