

**BS 8888:2017**



**BSI Standards Publication**

# **Technical product documentation and specification**

**bsi.**

**Publishing and copyright information**

The BSI copyright notice displayed in this document indicates when the document was last issued.

© The British Standards Institution 2017.  
Published by BSI Standards Limited 2017

ISBN 978 0 580 92686 0

ICS 01.100.01; 01.110

The following BSI references relate to the work on this standard:

Committee reference TDW/4/8

Draft for comment 16/30334592 DC

**Publication history**

First published as BS 308, September 1927

Second edition, December 1943

Third edition, December 1953

Fourth edition, November 1964

Published as BS 308-1, BS 308-2 and BS 308-3, October 1972

Second editions, August 1984 (BS 308-1), October 1985 (BS 308-2) and August 1990  
(BS 308-3)

Third edition of BS 308-1, December 1993

First published as BS 8888, August 2000

Second edition, October 2002

Third edition, October 2004

Fourth edition, October 2006

Fifth edition, October 2008

Sixth edition, December 2011

Seventh edition, December 2013

Eighth (present) edition, January 2017

**Amendments issued since publication**

Date	Text affected
------	---------------

---

# Contents

Foreword *vii*

## **Section 1: Scope 1**

- 1.1 Scope 1
- 1.2 Normative references 1
- 1.3 Terms and definitions 2

## **Section 2: Standards underpinning BS 8888 3**

- 2.1 General 3

## **Section 3: Technical product specification (TPS): Principles and concepts 4**

- 3.1 Principles of specification 4
- 3.2 Fundamental concepts 8
- 3.3 Geometrical product specification 13

## **Section 4: Technical product documentation (TPD) 15**

- 4.1 Graphical representation and annotation of 3D data (3D modelling output) 17
- 4.2 Drawing sheets 17
- 4.3 Line types and line widths 20
- 4.4 Scales 21
- 4.5 Lines 21
- 4.6 Number formats 22
- 4.7 Lettering 23
- 4.8 Projections 24
- 4.9 Views 27
- 4.10 Sections 28
- 4.11 Representation of components 30

## **Section 5: Technical product specification (TPS): Dimensioning 32**

- 5.1 General 32
- 5.2 Dimensioning methods 33
- 5.3 Dimensioning common features 56
- 5.4 Dimensional tolerancing 59

## **Section 6: Geometrical product specification – Datums and datum systems 65**

- 6.1 General 65
- 6.2 Definitions and explanations 65
- 6.3 Deriving datums from datum features 68
- 6.4 Indications of situation features in a technical product specification 78
- 6.5 Identifying datum features: Placement of the datum feature indicator 80
- 6.6 Common datums 83
- 6.7 Datum systems and the six degrees of freedom 87
- 6.8 Datum targets 89
- 6.9 Modifying the effects of datums 97

## **Section 7: Geometrical product specification – Tolerances 99**

- 7.1 Geometric tolerances 99
- 7.2 Basic concepts 99
- 7.3 Symbols 100
- 7.4 Tolerance frame 101
- 7.5 Toleranced features 102
- 7.6 Tolerance zones 104
- 7.7 Supplementary indications 114
- 7.8 Theoretically exact dimensions (TED) 115
- 7.9 Restrictive specifications 116
- 7.10 Projected tolerance zone 117
- 7.11 Maximum material requirement 118
- 7.12 Least material requirement 118

7.13	Free state condition	118
7.14	Interrelationship of geometrical tolerances	119
<b>Section 8: Surface texture specification</b> 120		
8.1	General	120
8.2	Characterization	121
8.3	Drawing indication of surface texture specification	126
8.4	Position and orientation of graphical symbol	128
8.5	Statistical tolerancing	131
<b>Section 9: Symbols and abbreviations</b> 132		
9.1	Symbols and abbreviations	132
<b>Section 10: Document handling</b> 134		
10.1	Types of documentation	134
10.2	Security	134
10.3	Storage	135
10.4	Marking	135
10.5	Protection notices	135
<b>Annexes</b>		
Annex A (normative) Normative references		136
Annex B (informative) Bibliography		142
Annex C (informative) Associations		143
Annex D (normative) Document security – Enhanced		145
Annex E (informative) Implementation in CAD		146
Annex F (informative) Tolerancing system: Former practice		148
Annex G (informative) Selected ISO fits: Hole and shaft basis		149
Annex H (informative) Filtration		152
<b>List of figures</b>		
Figure 1 – Hole and shaft sizes		5
Figure 2 – Interrelationship of the geometrical feature definitions		10
Figure 3 – Possible interpretations of size limits where no form control is defined and the specification is incomplete		12
Figure 4 – Example of assembly drawing		15
Figure 5 – Example of part drawing		16
Figure 6 – Example of fabrication drawing		16
Figure 7 – Size A4 to A0		18
Figure 8 – Title block in compact form		18
Figure 9 – Labelled view method		25
Figure 10 – First angle projection method		26
Figure 11 – First angle projection method: Graphical symbol		26
Figure 12 – Third angle projection method		27
Figure 13 – Third angle projection method: Graphical symbol		27
Figure 14 – Auxiliary view showing true shape of inclined surface		28
Figure 15 – Section view in one plane		29
Figure 16 – Section view in two parallel planes		29
Figure 17 – Section view in three contiguous planes showing true shape of inclined surface		30
Figure 18 – Positioning of dimensions		34
Figure 19 – Arrangement and indication of dimensions internal and external features		35
Figure 20 – Grouping of relative dimensions of features or objects in close proximity		35
Figure 21 – Elements of dimensioning		36
Figure 22 – Dimension line of feature that is broken		36
Figure 23 – Dimension lines of holes		37
Figure 24 – Extension lines		37
Figure 25 – Oblique extension lines		38



Figure 26 – Intersection of projected contours of outlines	38
Figure 27 – Intersection of projected contours of transitions and similar features	39
Figure 28 – Extension lines of angular dimensions	39
Figure 29 – Position of dimensional values	40
Figure 30 – Position of dimensional values	40
Figure 31 – Orientation of linear dimensions	41
Figure 32 – Orientation of angular dimensions	41
Figure 33 – Indications of special dimensions: Radius	42
Figure 34 – Indications of special dimensions: Square	42
Figure 35 – Indications of special dimensions: Spherical diameter	42
Figure 36 – Indications of special dimensions: Spherical radius	42
Figure 37 – Indications of special dimensions: Thickness	43
Figure 38 – Diameter and depth of counterbore	43
Figure 39 – Size and angle of countersink	43
Figure 40 – Number of equally-spaced features and the dimensional value	44
Figure 41 – Dimensioning of angular spacing	44
Figure 42 – Angles of spacings	45
Figure 43 – Indication of features having the same dimensional value	45
Figure 44 – Indication of features having the same dimensional value	46
Figure 45 – Dimension of external chamfer not equal to 45°	46
Figure 46 – Dimension of external chamfer equal to 45°	46
Figure 47 – Dimension of internal chamfer not equal to 45°	47
Figure 48 – Dimension of internal chamfer equal to 45°	47
Figure 49 – Dimension of countersink	47
Figure 50 – Dimension of countersink: simplification	48
Figure 51 – Symmetrical parts	48
Figure 52 – Symmetrical parts	49
Figure 53 – Symmetrical parts	49
Figure 54 – Indication of level on vertical view	50
Figure 55 – Indication of level on horizontal view or section	50
Figure 56 – Example of curved feature defined by radii	50
Figure 57 – Example of curved feature defined by radii	51
Figure 58 – Curved feature defined by coordinate dimensions	51
Figure 59 – Curved features defined by coordinate dimensions	51
Figure 60 – Example of chain dimensioning	52
Figure 61 – Example of parallel dimensioning	52
Figure 62 – Example of parallel dimensioning	53
Figure 63 – Two dimension lines, inclined to each other, and two origins	54
Figure 64 – Running dimensioning of angles	54
Figure 65 – Cartesian coordinate dimensioning	55
Figure 66 – Cartesian coordinate dimensioning	56
Figure 67 – Dimensioning of keyways	57
Figure 68 – Example: expression of two deviations to the same number of decimal places	60
Figure 69 – Example: expression of two limits of size to the same number of decimal places	60
Figure 70 – Example: expression of deviations from dimensions displayed in accordance with BS EN ISO 286-1	60
Figure 71 – Components of a toleranced dimension	60
Figure 72 – Components of a toleranced dimension	61
Figure 73 – Components of a toleranced dimension	61
Figure 74 – Limits of dimensions	61
Figure 75 – Single limit dimension	61
Figure 76 – Use of general tolerance notes	62
Figure 77 – Application of dimensions to suite functional requirements	63

- Figure 78 – Effect of changing datum surfaces from those determined by functional 64
- Figure 79 – Tolerance defining a datum system 66
- Figure 80 – Degrees of freedom 66
- Figure 81 – Datum based on a planar datum feature 69
- Figure 82 – Tangent plane 69
- Figure 83 – Datum based on two parallel, opposed planes 70
- Figure 84 – Datum feature consisting of a non-ideal cylinder 71
- Figure 85 – Datum feature consisting of a non-ideal sphere 72
- Figure 86 – Datum feature consisting of a non-ideal cone 74
- Figure 87 – Datum feature consisting of a non-ideal wedge 75
- Figure 88 – Datum for prismatic feature 76
- Figure 89 – Non-ideal prismatic surface 76
- Figure 90 – Associated feature of prismatic surface 77
- Figure 91 – Situation features for prismatic surface 77
- Figure 92 – Degrees of freedom that can be controlled 77
- Figure 93 – Datum feature consisting of a non-ideal complex surface 78
- Figure 94 – Example identifiers for situation features 79
- Figure 95 – Common datum established by a group of identical features 83
- Figure 96 – Common datum established from two coaxial cylinders 84
- Figure 97 – Establishing a common datum from two coaxial cylinders 84
- Figure 98 – Establishing a common datum from two parallel cylinders 85
- Figure 99 – Pattern of five cylinders: input for reading (drawing indication) and for writing (design intent) 85
- Figure 100 – Establishing a common datum from a pattern of five cylinders 86
- Figure 101 – Association for a common datum based on two coaxial cylinders 87
- Figure 102 – Single datum target frame 90
- Figure 103 – Datum target point 90
- Figure 104 – Open datum target line 90
- Figure 105 – Datum target area 91
- Figure 106 – Indicator for single datum target point 91
- Figure 107 – Indicator for single datum target line 91
- Figure 108 – Indicator for single datum target surface 92
- Figure 109 – Indicator for single datum target area 92
- Figure 110 – Direct and indirect indication for single datum target area 92
- Figure 111 – Indication of datums established from datum targets 93
- Figure 112 – Simplification of drawing indication when there is only one datum target area 93
- Figure 113 – Datums based on more than one datum target 94
- Figure 114 – Application of datum targets 95
- Figure 115 – Application of datum targets 96
- Figure 116 – Examples of complementary indication 96
- Figure 117 – Application of “orientation-only” modifier 97
- Figure 118 – Indication of which modifier is needed in the set of situation features 98
- Figure 119 – Tolerance applying to more than one feature 102
- Figure 120 – Indications qualifying the form of the feature within the tolerance zone 102
- Figure 121 – Requirements given in tolerance frames one under the other 102
- Figure 122 – Terminator on the outline or the surface of a feature or as an extension 103
- Figure 123 – Terminator as an extension of the dimension line 103
- Figure 124 – Width of tolerance zone applying to the specified geometry 104
- Figure 125 – Width of tolerance zone, otherwise indicated 105
- Figure 126 – Orientation of the width of a positional tolerance zone 105
- Figure 127 – Orientation of the width of an orientation tolerance zone 106
- Figure 128 – Tolerances perpendicular to each other 106

Figure 129 – Cylindrical and circular tolerance zones	107
Figure 130 – Tolerance zones applied to separate features	107
Figure 131 – Single tolerance zone applied to separate features	108
Figure 132 – Examples of geometrical tolerancing	108
Figure 133 – Examples of the use of the “all around” symbol	114
Figure 134 – Examples of “MD” and “LD”	115
Figure 135 – Use of theoretically exact dimensions (TEDs)	115
Figure 136 – Examples of tolerances of the same characteristic	116
Figure 137 – Tolerance applied to a restricted part of a feature	116
Figure 138 – Tolerance applied to an area	117
Figure 139 – Two ways of indicating a geometrical specification with projected tolerance modifier	117
Figure 140 – Indication of the maximum material requirement	118
Figure 141 – Indication of the least material requirement	118
Figure 142 – Free state condition	118
Figure 143 – Use of several specification modifiers	118
Figure 144 – Use of several specification modifiers	122
Figure 145 – Mathematical derivation of $R_a$ and $R_q$	123
Figure 146 – Peak height ( $R_p$ ), valley depth ( $R_v$ ) and maximum height of profile ( $R_z$ )	123
Figure 147 – Mathematical derivation of surface skewness ( $R_{sk}$ )	124
Figure 148 – Derivation of mean width of profile element ( $R_{Sm}$ )	125
Figure 149 – Surface texture graphical symbol	126
Figure 150 – Positions (a to e) for location of texture requirements	126
Figure 151 – Attachment of surface texture requirement to workpiece	128
Figure 152 – Surface texture requirement: Geometrical tolerance indication	128
Figure 153 – Simplified indication: Majority of surfaces with same surface texture requirement	129
Figure C.1 – Example of individual specification operator for a datum association	145
Figure E.1 – Implementation according to BS 8888 and BS EN ISO 5459	147
Figure E.2 – Implementation according to most CAD software	147
Figure F.1 – BS 8888 independency system symbol	148
Figure F.2 – BS 8888 dependency system symbol	148

#### List of tables

Table 1 – Mean and nominal values for 3D CAD model	5
Table 2 – Level of detail in a TPS	6
Table 3 – Sizes of trimmed and untrimmed sheets and the drawing space	17
Table 4 – Identifying, descriptive and administrative data fields in the title block	19
Table 5 – Number of fields	19
Table 6 – Basic line types	20
Table 7 – Scales	21
Table 8 – Preferred line widths and lettering heights for drawing sheet sizes	23
Table 9 – Examples of indication of edges	58
Table 10 – Permissible deviations for linear dimensions except for broken edges	62
Table 11 – Permissible deviations for broken edges (external radii and chamfer heights)	62
Table 12 – Permissible deviations of angular dimensions	63
Table 13 – Situation features	67
Table 14 – Example: single datum	82
Table 15 – Examples: datum systems	88
Table 16 – Examples: datum systems	89
Table 17 – Symbols for geometrical characteristics	100
Table 18 – Additional symbols	101
Table 19 – Estimates for choosing roughness sampling lengths for the measurement of non-periodic profiles ( $R_a$ )	124

Table 20 – Estimates for choosing roughness sampling lengths for the measurement of non-periodic profiles ( $R_z$ )	125
Table 21 – Estimates for choosing roughness sampling lengths for the measurement of periodic profiles	125
Table 22 – Indication of surface lay	127
Table 23 – Example application of surface texture	130
Table C.1 – Default association operations used when defining datums	144
Table G.1 – Selected ISO fits: Hole basis	149
Table G.2 – Selected ISO fits: Shaft basis	150

#### **Summary of pages**

This document comprises a front cover, an inside front cover, pages i to viii, pages 1 to 154, an inside back cover and a back cover.

## Foreword

### Publishing information

This British Standard is published by BSI Standards Limited, under licence from The British Standards Institution, and came into effect on 31 January 2017. It was prepared by Technical Committee TDW/4/8, *BS 8888 Technical product specification*, under the authority of Technical Committee TDW/4, *Technical product realization*. A list of organizations represented on these committees can be obtained on request to their secretary.

### Supersession

This British Standard supersedes BS 8888:2013, which is withdrawn.

### Information about this document

This edition of the standard is a full revision. It introduces relevant international standards published since the 2013 edition. It also incorporates more fully than previous editions some of the fundamental requirements of the key international standards relevant to the preparation of technical product specifications, such as BS EN ISO 1101 and BS EN ISO 5459. It is hoped that UK industry will find this edition of BS 8888 more user-friendly than previous editions. It aims to help organizations better understand and implement the full complement of international standards developed by ISO/TC 213, *Geometrical product specifications and verification*, and ISO/TC 10, *Technical product documentation*.

### Relationship with other publications

The function of BS 8888 is to draw together, in an easily accessible manner, the full complement of international standards relevant to the preparation of technical product specifications. However, it is not the intention for BS 8888 to be a “stand-alone” standard. TDW/4 is responsible for a suite of related national standards, including the various parts of BS 8887, BS 8889<sup>1)</sup> and PD 68888, a new training document.

BS 8888 was taken up by the Ministry of Defence in 2006 as part of its DEF-STAN for defence project specification.

### Presentational conventions

The provisions of this standard are presented in roman (i.e. upright) type. Its requirements are expressed in sentences in which the principal auxiliary verb is “shall”.

*Commentary, explanation and general informative material is presented in smaller italic type, and does not constitute a normative element.*

In addition, information boxes provide additional informative material that might otherwise have appeared in informative annexes, but was felt to be best placed in the main body of text.

All dimensions shown in the figures in this British Standard are in millimetres.

### Contractual and legal considerations

This publication does not purport to include all the necessary provisions of a contract. Users are responsible for its correct application.

**Compliance with a British Standard cannot confer immunity from legal obligations.**

---

<sup>1)</sup> In development.



# Section 1: Scope

## 1.1 Scope

This British Standard specifies requirements for technical product documentation and specification, principally for manufacturing industries and organizations associated with engineering disciplines, such as mechanical, electrical, nuclear, automotive and aerospace.

The needs of building, architectural, civil, and structural engineering and construction services industries continue to be covered by the BS 1192 series of standards.

Most of this British Standard consists of an implementation of the ISO system for technical product documentation and specification. The ISO system is defined in a large number of interlinked and related international standards which are referenced in this British Standard.

The purpose of this British Standard is to facilitate the use of the ISO system by providing:

- an index to the international standards which make up the ISO system, referencing them according to their area of application;
- key elements of the ISO standards to facilitate their application;
- references to additional British and European standards where they provide information or guidance over and above that provided by ISO standards; and
- commentary and recommendations on the application of the standards where this is deemed useful.

The requirements refer to international and European standards which have been implemented as British Standards, either in the BS EN, BS EN ISO, BS ISO series or as international standards renumbered as British Standards.

Annex A (normative) contains a list of normative references, indispensable for the application of this British Standard.

Annex B (informative) contains a list of informative references.

Annex C (informative) gives information about association.

Annex D (normative) contains requirements for enhanced security.

Annex E (informative) gives information about the implementation of datums and datum features in CAD.

Annex F (informative) demonstrates former practice for tolerancing.

Annex G (informative) gives selected ISO fits for holes and shafts.

Annex H (informative) explains how data representing a manufactured surface are filtered by the measurement process.

## 1.2 Normative references

The documents listed in Annex A, in whole or in part, are normatively referenced in this document and are indispensable for its application. For dated references, only the edition cited applies. For undated references, the latest edition of the referenced document (including any amendments) applies.



## 1.3 Terms and definitions

For the purposes of this British Standard, the terms and definitions given in BS EN ISO 10209 and BS EN ISO 14660-1 apply, together with the following.

### 1.3.1 date of issue

point in time at which the technical product specification is officially released for its intended use

*NOTE 1 The date of issue is important for legal reasons, e.g. patent rights, traceability.*

*NOTE 2 For the implications of the date of issue, see 3.1.3.*

### 1.3.2 ISO GPS system

geometrical product specification and verification system developed in ISO by ISO/TC 213

### 1.3.3 technical product documentation (TPD)

means of conveying all or part of a design definition or specification of a product

### 1.3.4 technical product specification (TPS)

technical product documentation comprising the complete design definition and specification of a product for manufacturing and verification purposes

*NOTE A TPS, which might contain drawings, 3D models, parts lists or other documents forming an integral part of the specification, in whatever format they might be presented, might consist of one or more TPDs.*

## Section 2: Standards underpinning BS 8888

### 2.1 General

The following documents shall be applied as “global” standards in support of BS 8888.

ISO/IEC Guide 98-3 *Guide to the expression of uncertainty in measurement (GUM)*

ISO/IEC Guide 99 *International vocabulary of metrology – Basic and general concepts and associated terms (VIM)*

The principles in Section 3 shall always be applied where conformity with BS 8888 is claimed.

## Section 3: Technical product specification (TPS): Principles and concepts

### 3.1 Principles of specification

#### 3.1.1 Types of technical product specification

##### 3.1.1.1 2D TPS (2D drawing only)

*COMMENTARY ON 3.1.1.1*

*This subclause relates to a 2D drawing in hardcopy or electronic format. Although 3D CAD can be used to derive the 2D drawing, the 3D model does not form any part of the TPS.*

A 2D TPS shall consist of 2D drawing information only. The drawing(s) shall provide all the necessary views, sections, datums, dimensions, tolerances and general notation to provide suitable and sufficient information to manufacture and verify the workpiece.

*NOTE* A workpiece may consist of a component or an assembly.

##### 3.1.1.2 Combined 3D and 2D TPS

*COMMENTARY ON 3.1.1.2*

*This subclause relates to a 2D drawing (specification) with 3D CAD geometry (definition) which in combination fully specifies a component or assembly. A 3D/2D TPS uses both 3D models and 2D drawings in combination to provide suitable and sufficient information to manufacture and verify the workpiece.*

A combined 2D and 3D TPS shall conform to BS ISO 16792.

In the absence of any dimension on the drawing, values shall be obtained from an interrogation of the 3D model geometry.

Unless otherwise stated, all tolerance requirements shall appear on the 2D drawing.

Unless otherwise stated, any dimension explicitly defined in any 2D TPS shall take precedence over any dimension obtained by interrogating the 3D model.

##### 3.1.1.3 3D TPS (3D CAD model only)

*COMMENTARY ON 3.1.1.3*

*This subclause relates to 3D CAD data in electronic format. There is no 2D drawing.*

A 3D TPS shall conform to BS ISO 16792.

The 3D TPS fully specifies all geometry, datums, dimensions and tolerances in order to provide suitable and sufficient information to manufacture and verify the workpiece. A 3D TPS shall consist of 3D model information only. The 3D model(s) shall provide the CAD nominal geometry and sufficient datums, dimensions, tolerances and general notation necessary to provide suitable and sufficient information to manufacture and verify the workpiece.

##### 3.1.1.4 Working with 3D CAD data

*COMMENTARY ON 3.1.1.4*

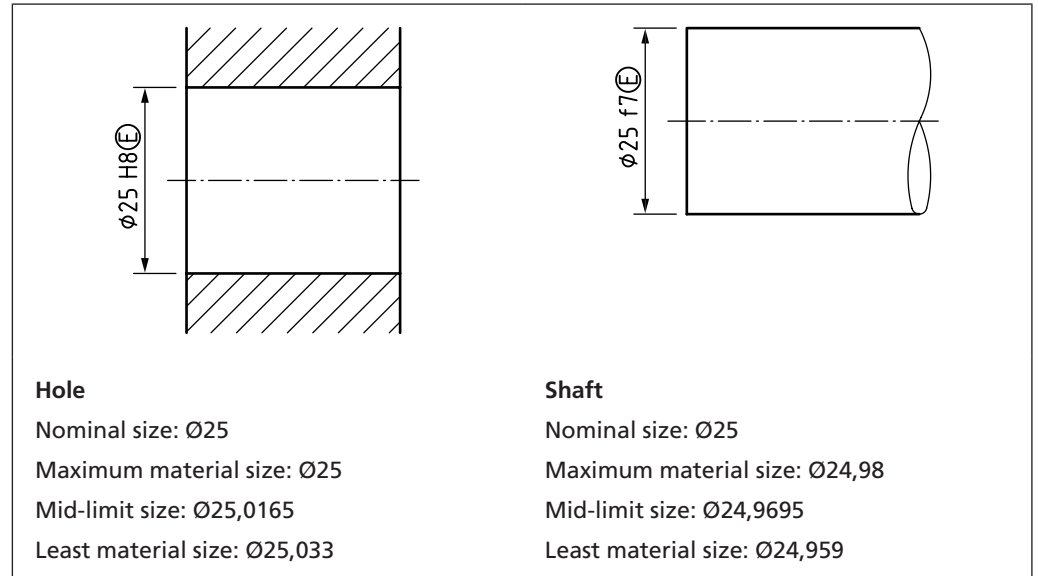
*See BS ISO 16792.*

*Where the 3D CAD geometry includes features of size, two different practices are widely used. These are to model the feature at "nominal" size or to model the feature at "mid-limit" size (see Figure 1).*

"Nominal" size is the dimension size to which the tolerance is applied. "Mid-limit" size is the size half-way through the tolerance range.

Where symmetrical size tolerances are used, "nominal" and "mid-limit" are the same. When non-symmetrical tolerances are used, such as limit and fit codes, they are different.

Figure 1 Hole and shaft sizes



When a nominal size is provided by means of a specification or dimension, all features of size can be modelled to nominal size or to mid-limit value of the tolerance limits. Where a nominal size is not provided, all features of size shall be modelled to the mid-limit value of the tolerance limits, unless otherwise stated (see Table 1).

Within a 3D CAD model, wherever non-symmetrical size tolerances are used, one practice shall be consistently followed.

Table 1 Mean and nominal values for 3D CAD model

Dimension	Nominal value	Value to be modelled when working to nominal	Mid-limit value	Value to be modelled when working to "mid-limit"
Ø <sub>13</sub> <sup>15</sup>	Not stated	Ø14	Ø14	Ø14
20,4 19,6	Not stated	20	20	20
10 ±1	10	10	10	10
Ø25 H8(E)	25	25	25,0165	Ø25,0165
Ø25 f7(E)	25	25	24,9695	Ø24,9695
Ø13,5 <sup>+1,5</sup> <sub>-0,5</sub>	13,5	13,5	14	Ø14
Ø14 <sup>+1</sup> <sub>0</sub>	14	14	14,5	Ø14,5
R0,5 MAX	R0,5	R0,5	R0,25 <sup>A)</sup>	R0,25

<sup>A)</sup> Min. value = 0.

### 3.1.2 General principles of specification

#### COMMENTARY ON 3.1.2

*When a specification leaves certain requirements undefined, or open to more than one interpretation, it is ambiguous. The ambiguity in a specification is known as "specification uncertainty".*

*The higher the specification uncertainty, the greater the risk that a manufactured product conforms to that specification, but is still unfit for purpose. Conversely, there is also greater risk of rejecting a workpiece which is fit for purpose.*

*The lower the specification uncertainty, the greater the chance that the manufactured product is fit for purpose.*

The specifier shall determine what level of specification uncertainty is acceptable, and define the workpiece in an appropriate manner (see Table 2).

*NOTE 2 For instance, a high level of specification uncertainty may be acceptable when the specifier is willing to rely on the skill, craftsmanship and knowledge of the manufacturer or fitter to achieve a satisfactory result. The benefit is a very simple specification, but the consequences could include a high degree of variation from one part to the next, a lack of interchangeability and inconsistent quality.*

*Higher levels of specification uncertainty also mean much greater chances of disputes over whether a manufactured product is acceptable or not.*

*The use of datums, geometrical tolerances, surface texture requirements and edge tolerances is not obligatory. However, not using these specification elements results in greater specification uncertainty.*

Table 2 Level of detail in a TPS

Specification elements included	Level of detail			
	Sketch	Technical model/ drawing	Technical model/ drawing with geometrical tolerancing	ISO GPS specification
3D/2D geometry	✓	✓	✓	✓
Dimensions		✓	✓	✓
+/- Tolerances		✓	✓	✓
Datums			✓	✓
Geometrical tolerances			✓	✓
Surface texture requirements				✓
Edge tolerances				✓
Filtration				✓
Specification uncertainty	Very high	High	Low	Very low

### 3.1.3 Date of issue principle

A TPS shall always be interpreted according to those versions of standards which governed its interpretation on its date of issue.

*NOTE What is not specified in a TPS at the date of issue cannot be required.*

### 3.1.4 Reference conditions

Unless otherwise stated, all geometrical properties and tolerances for a workpiece given in a TPS shall be considered to apply at 20 °C.

*NOTE 1 See BS EN ISO 1.*

By default, all GPS specifications shall apply at reference conditions, including the workpiece's freedom from contaminants.

*NOTE 2* See BS EN ISO 8015.

Any additional or other conditions that apply, e.g. humidity conditions, shall be defined on the drawing.

### 3.1.5 Interpretation

A TPS shall indicate which standards, or systems of standards, govern its interpretation.

When the format of data in a TPS conforms to the British and ISO standards identified in BS 8888, a reference to BS 8888 itself shall be sufficient to indicate that these standards apply to the specification. Such a reference shall take the following form.

#### CONFORMS TO BS 8888

*NOTE 1* This note may be placed in the title block, in a drawing note, or elsewhere within the drawing frame.

*NOTE 2* The phrase "format of data" refers to 2D and 3D TPS, and includes aspects such as format of attributes, layout of drawing borders and title blocks, layout of views and projections, format of letters, numbers, dimensions and tolerances, and use of different line types and thicknesses.

When the geometry of a workpiece is defined according to the requirements of ISO GPS (see 3.3 and Annex F), which are documented in standards such as BS EN ISO 5459 and BE EN ISO 1101, a reference to BS EN ISO 8015 is sufficient to indicate that all ISO GPS standards apply to the interpretation of that specification. Such a reference shall take the following form.

#### TOLERANCING ISO 8015

*NOTE 3* This note may be placed in the title block, in a drawing note, or elsewhere within the drawing frame. This note is required in addition to any reference to BS 8888.

*This marking is a BS 8888 requirement, and not a requirement of BS EN ISO 8015. This is necessary to avoid possible misinterpretation of which system of standards govern the interpretation of a TPS.*

### 3.1.6 Decimal principle

Non-indicated decimals shall be taken as zeroes.

*NOTE 1* 0,2 is the same as 0,200 000 000 000 000 000 000 000 000 ... etc.

*NOTE 2* 10 is the same as 10,000 000 000 000 000 000 000 000 000 ... etc.

### 3.1.7 Rigid workpiece principle

Unless otherwise stated, a workpiece shall be considered as having infinite stiffness, and all geometrical properties and tolerances given in a TPS shall be considered to apply in the absence of deformation from any external forces (including gravity). Any additional or other conditions that apply shall be defined in the drawing.

### 3.1.8 Non-rigid workpieces

In some cases the rigid workpiece principle does not apply. A non-rigid workpiece is one that deforms to an extent that in the free state it is beyond the dimensional and/or geometrical tolerances on the drawing. A non-rigid workpiece shall

therefore have the free state deformation removed for verification by applying pressure or force in some manner.

*NOTE 1 This is known as the “restrained condition”. The restrained condition normally corresponds to the assembly condition, but might also correspond to certain operational conditions. Dimensions, tolerances and geometrical tolerances may be applied to either the free state, or to the restrained condition, or to both.*

*NOTE 2 Free state is the condition of a part subjected only to the force of gravity.*

*NOTE 3 This is of particular importance when aligning and/or measuring large and/or flexible constructions.*

A non-rigid workpiece is one that deforms to an extent that in the free state it is beyond the dimensional and/or geometrical tolerances on the drawing. A non-rigid workpiece shall therefore have the free state deformation removed for verification by applying pressure or forces that replicate, but do not exceed, those expected under normal assembly conditions. This is known as the restrained condition.

A TPS for a non-rigid workpiece shall include:

- a) the indication ISO10579-NR near the title block or in the notes;
- b) a definition of restraint, e.g. use of tooling, application of forces or pressure, if necessary an indication of the direction of gravity; and
- c) if required, a definition of the condition under which free state tolerances apply, e.g. orientation and direction of gravity.

*NOTE 4 When BS ISO 10579-NR is indicated on the drawing, all dimensions, tolerances and geometrical tolerances apply to the restrained condition unless otherwise stated. Any dimensions, tolerances and geometrical tolerances which apply to the free state are identified with the  $\text{\textcircled{F}}$  symbol (see 7.13).*

## 3.2 Fundamental concepts

### 3.2.1 Properties

A TPS defines various properties and requirements. Some properties or requirements may be defined for an entire workpiece (e.g. a material specification), some for part of a workpiece (e.g. a particular surface treatment), and some for individual features on a workpiece (e.g. a size requirement).

Properties or requirements may also be defined for a process or procedure.

Properties which may be specified include:

- size;
- location;
- orientation;
- form;
- surface texture;
- surface imperfections;
- properties of edges;
- material;
- coatings and finishes;
- hardness;



- chemical composition;
- treatments which are to be applied to the workpiece;
- processing requirements;
- recycling requirements;
- packaging requirements; and
- handling requirements.

Properties of location and orientation may be defined solely with toleranced dimensions (see Section 5), but this results in ambiguous specifications which are open to a wide range of interpretations.

For an unambiguous definition of the size, location, orientation and form of features on the workpiece, the ISO system of Geometrical Product Specification shall be used.

*NOTE This utilizes datums and geometrical tolerances to minimize ambiguity (see Section 6 and Section 7).*

### 3.2.2 Feature principle

A workpiece shall be considered to be made up of a number of features limited by natural boundaries. By default, every specification requirement for a feature or relation between features shall apply to the entire feature and each specification requirement shall apply only to one feature or one relation between features.

*NOTE This default can only be overridden by explicit indications on the drawing. The system for classifying features is outlined in the following information box.*

#### Classification of features

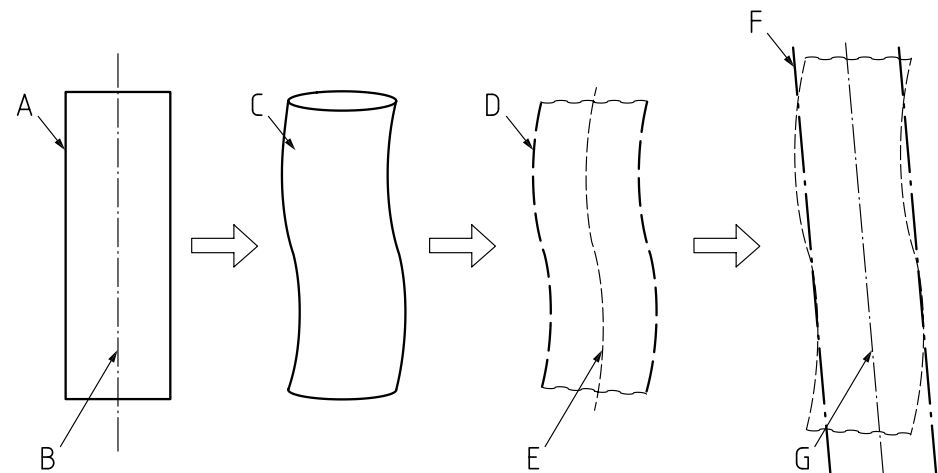
ISO GPS defines several different types of feature. The main types of features are:

- a. integral features: features which consist of, or represent, surfaces on the workpiece;
- b. features of size: integral features which have a size characteristic and can consist of:
  1. two parallel opposed planes;
  2. a cylinder;
  3. a sphere;
  4. two non-parallel planes (a wedge);
  5. a cone; and
  6. a torus;
- c. derived features: theoretical features such as axes or median lines, which are derived from a feature of size (axis or median line, median plane or median surface, and centre points).

ISO GPS also defines a number of different "worlds" or "states" in which features can exist. In some "worlds" the features exist in an ideal form, such as in the specification, while in other states they exist in a non-ideal form, such as surfaces on the manufactured workpiece.

*NOTE 1 See Figure 2.*

Figure 2 Interrelationship of the geometrical feature definitions

**Key**

A	Nominal integral feature	E	Extracted derived feature
B	Nominal derived feature	F	Associated integral feature
C	Real feature	G	Associated derived feature
D	Extracted integral feature		

**Nominal features**

In the “world” of the specification, features are represented in an ideal state. These features have ideal form, and ideal relationships with each other. Features in this world are known as nominal features.

**Real features**

In the “world” of the manufactured workpiece (the physical world), features are non-ideal and are known as real features.

**Extracted features**

In the “world” of verification, a feature is represented by a set of data obtained by sampling the workpiece with measuring instruments. This set of data represents the non-ideal real feature, and is known as an extracted feature.

*NOTE 2 The extracted feature is used when determining whether a tolerance requirement has been met.*

**Associated features**

In the “world” of verification, an ideal feature may be “fitted” to, or associated with, either the real feature or the extracted feature. This ideal feature is known as an associated feature.

*NOTE 3 The associated feature is used when determining the orientation of size measurements, or when defining a datum. A range of different association methods may be used.*

### 3.2.3 Interpretations of limits of size for a feature of size

#### 3.2.3.1 General

BS EN ISO 14405-1 states that the default definition of a size tolerance is the “two-point” definition. This means that size limits only apply to any “two-point” size measurement of a feature. Therefore, the size limits do not control the form deviations of the feature. For example:

- the size limits on a cylindrical feature do not control its roundness or straightness;
- the size limits on a feature consisting of two parallel, opposed planes do not control the flatness of the two planes.

Form deviations can be controlled by:

- individually specified geometrical tolerances;
- general geometrical tolerances; or
- the use of the envelope requirement (where the maximum material limit of size defines an envelope of perfect form for the relevant surfaces, see BS EN ISO 14405-1).

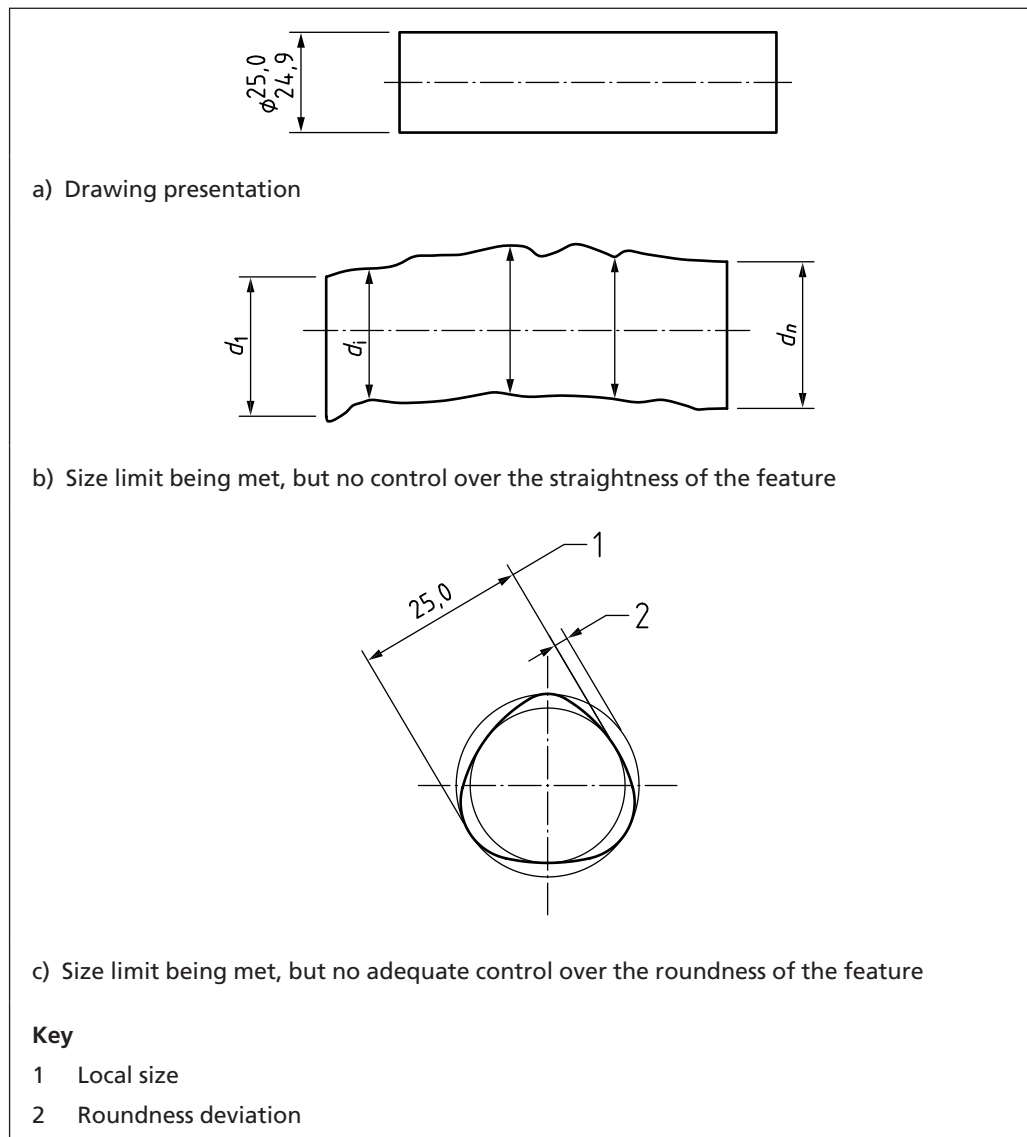
Limits of size for an individual feature of size shall be interpreted according to the principles and rules defined in the following standards.

*NOTE* Figure 3 gives examples of how size limits could be interpreted where no form control is defined and the specification is incomplete.

BS EN ISO 8015	<i>Geometrical product specifications (GPS) – Fundamentals – Concepts, principles and rules</i>
BS EN ISO 14405-1	<i>Geometrical product specifications (GPS) – Dimensional tolerancing – Part 1: Linear sizes</i>
BS EN ISO 14660-1	<i>Geometrical Product Specifications (GPS) – Geometrical features – Part 1: General terms and definitions</i>
BS EN ISO 14660-2	<i>Geometrical Product Specifications (GPS) – Geometrical features – Part 2: Extracted median line of a cylinder and a cone, extracted median surface, local size of an extracted feature<sup>2)</sup></i>

<sup>2)</sup> Withdrawn.

Figure 3 Possible interpretations of size limits where no form control is defined and the specification is incomplete



### 3.2.3.2 Limits of size with mutual dependency of size and form

Some national standards apply, or have applied, the envelope requirement to all features of size by default. As the envelope requirement has been the default, they have not used a symbol to indicate this requirement; rather, they use a note to indicate when this is not required. This system of tolerancing is sometimes described as the principle of dependency, or the application of the Taylor Principle.

Standards which apply, or have applied, the envelope requirement by default include BS 308, ASME Y14.5 [1] and DIN 7167<sup>3)</sup> (the requirement that there is an envelope of perfect form corresponding to the maximum material size of the feature is defined as Rule #1 in ASME Y14.5 [1]).

BS EN ISO 14405-1 allows the default interpretation of size requirements to be changed for a TPS. A number of different possibilities are available, including the option of making the envelope requirement the default interpretation of size for the entire specification.

<sup>3)</sup> Withdrawn.

If the default interpretation of size is to be changed for a TPS, the following indication shall appear in or near the title block of each drawing:

SIZE ISO 14405

followed by the relevant modifier.

For example, if the envelope requirement is to be made the default interpretation of size requirements for the entire TPS, the indication shall be:

SIZE ISO 14405 (E)

*NOTE* It is recommended that a note on the drawing be used in addition to the ISO 14405 reference, for clarity.

### 3.2.3.3 Implied dimensions

The following rules shall govern the use and interpretation of implied annotation on engineering drawings.

*NOTE 1* A dimension may be implied and not indicated on a drawing in the following circumstances, so long as there is no risk of misinterpretation.

*NOTE 2* Tolerances should never be implied, and should always be indicated. Datums should never be implied, and should always be indicated.

- a) Where two features are aligned, there is no requirement to indicate a linear dimension of 0 or an angular dimension of 0°.
- b) Where two features are parallel to each other, there is no requirement to indicate an angular dimension of 0° or 180°.
- c) Where two features are at 90° to each other, there is no requirement to indicate an angular dimension of 90°.
- d) Where several features are equispaced around a pitch circle (see BS ISO 129-1), there is no requirement to indicate an angular dimension, although it might be advisable to do so. Terms such as "equispaced", "equally spaced", etc., shall not be used.
- e) Where not otherwise indicated, holes are considered as through holes.
- f) If the features concerned have their locations and/or orientations controlled through the use of geometrical tolerances, then the implied dimensions shall be taken as theoretically exact dimensions (TEDs; see 7.8).
- g) If the features concerned have their locations and/or orientations controlled through the use of +/- or limit tolerances, then the implied dimensions shall also be tolerated. In the absence of other indications, they shall be subject to a general tolerance, or else the TPS would remain incomplete (see 5.4).

## 3.3 Geometrical product specification

### 3.3.1 Interpretation and invocation principle

Once a portion of the ISO GPS system is invoked on a mechanical engineering product specification, the entire ISO GPS system shall be invoked, unless otherwise indicated on the specification, e.g. by reference to a relevant document.

"Unless otherwise indicated on the specification" means that it is indicated on the specification that this has been prepared in accordance with a certain standard. That standard, and not the ISO GPS system, shall be used to interpret those elements of the specification which are covered by that standard.

*NOTE 1 The ISO GPS system is defined in a hierarchy of standards that includes the following types of standards in the given order:*

- *fundamental GPS standards;*
- *general GPS standards; and*
- *complementary GPS standards.*

*See ISO/TR 14638 for further details.*

The “entire ISO GPS system shall be invoked” means that fundamental and general GPS standards shall apply and, consequently, that the reference temperature given in BS EN ISO 1 and the decision rules given in BS EN ISO 14253-1 shall apply, unless otherwise indicated.

*NOTE 2 The purpose of the invocation principle is to provide the formal traceability for these GPS standards and rules.*

The rules given in standards at a higher level in the hierarchy shall apply in all cases, unless rules in standards at lower levels in the hierarchy specifically give other rules.

All rules given in fundamental GPS standards shall apply, in addition to those specifically given in general GPS standards, e.g. BS EN ISO 1101, except where the rules in the general GPS standard are explicitly different from the rules given in fundamental GPS standards and unless the rules in a specific complementary GPS standard give other rules that apply within its scope.

All rules given in fundamental and general GPS standards shall apply in addition to the rules specifically given in complementary GPS standards, e.g. BS EN 22768-1, except in the cases where the rules in the complementary GPS standard are explicitly different from the rules given in fundamental and general GPS standards.

### 3.3.2 **Independency principle**

By default, every GPS requirement for a feature or relation between features shall be fulfilled independently of other requirements, except when it is stated in a standard or by special indication (e.g. modifiers  $\textcircled{M}$  according to BS EN ISO 2692 or CZ) as part of the actual specification.

# Section 4: Technical product documentation (TPD)

Various types of documents are used to provide appropriate technical information to define the features and requirements for a component or assembly (see Section 3). The most commonly used document types are as follows. See BS ISO 29845 for further document types.

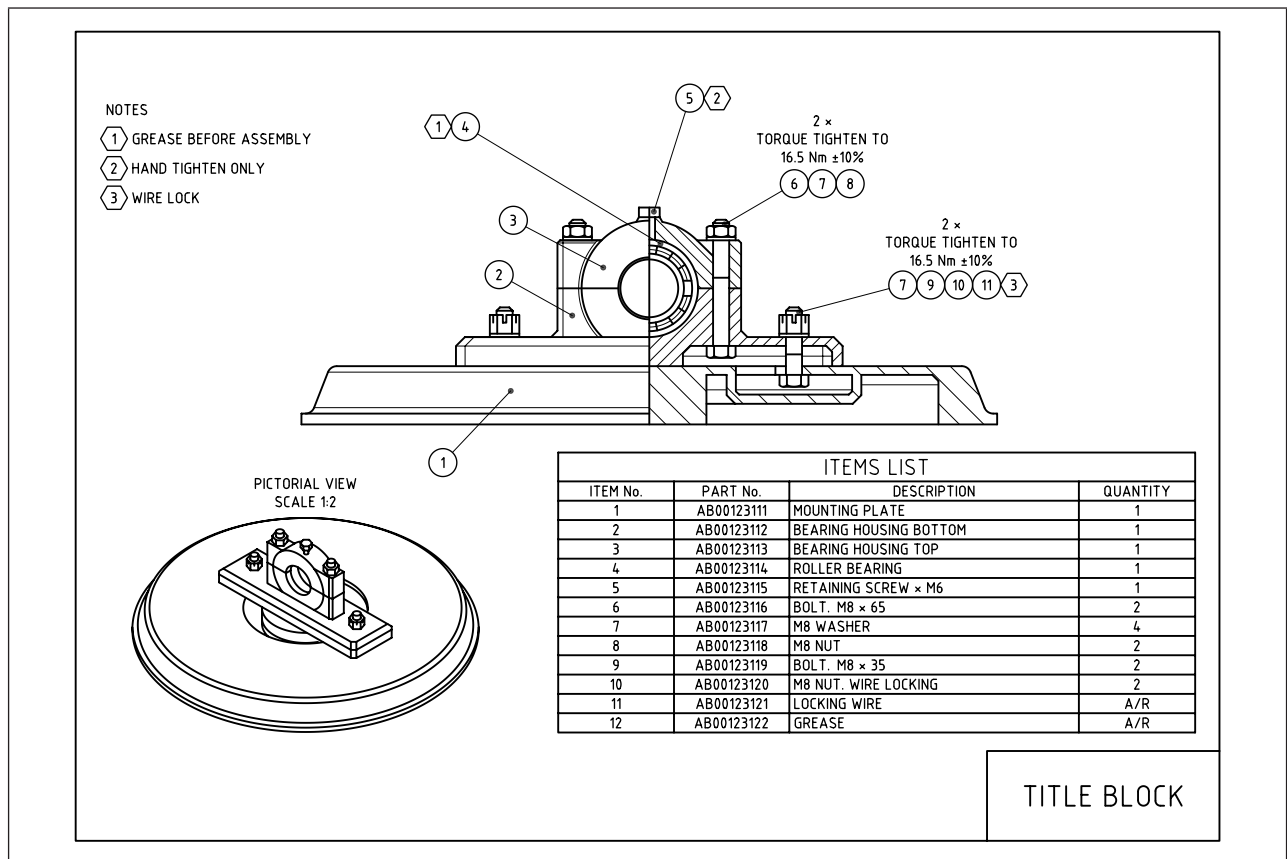
### Assembly drawing

An assembly drawing (see Figure 4) represents the relative position and/or shape of a group of assembled parts. It depicts the constituents of a parts list.

The list of parts is normally provided in a separate document, i.e. a parts list, but can be included within the drawing, with the individual parts annotated with ballooned numbers matching the item numbers in the parts list.

Relevant information can also be added, torque settings can either be shown adjacent to the item balloon or in a torque table, and other information, e.g. lubricating grease, thread adhesive, can be shown alongside corresponding flag notes. Overall and key dimensions can also be included, along with mass and centre of gravity.

Figure 4 Example of assembly drawing



### Part drawing

A part drawing includes all the necessary information required for the complete and unambiguous definition of the part, e.g. material properties, dimensions, tolerances, surface texture (see Figure 5).

### Fabrication drawing

A fabrication drawing depicts a workpiece which is permanently joined together by means of welding, brazing, adhesion or other method. The constituents need to be fully specified. A parts list can be included on the drawing along with simple profile cut lengths (see Figure 6).



Figure 5 Example of part drawing

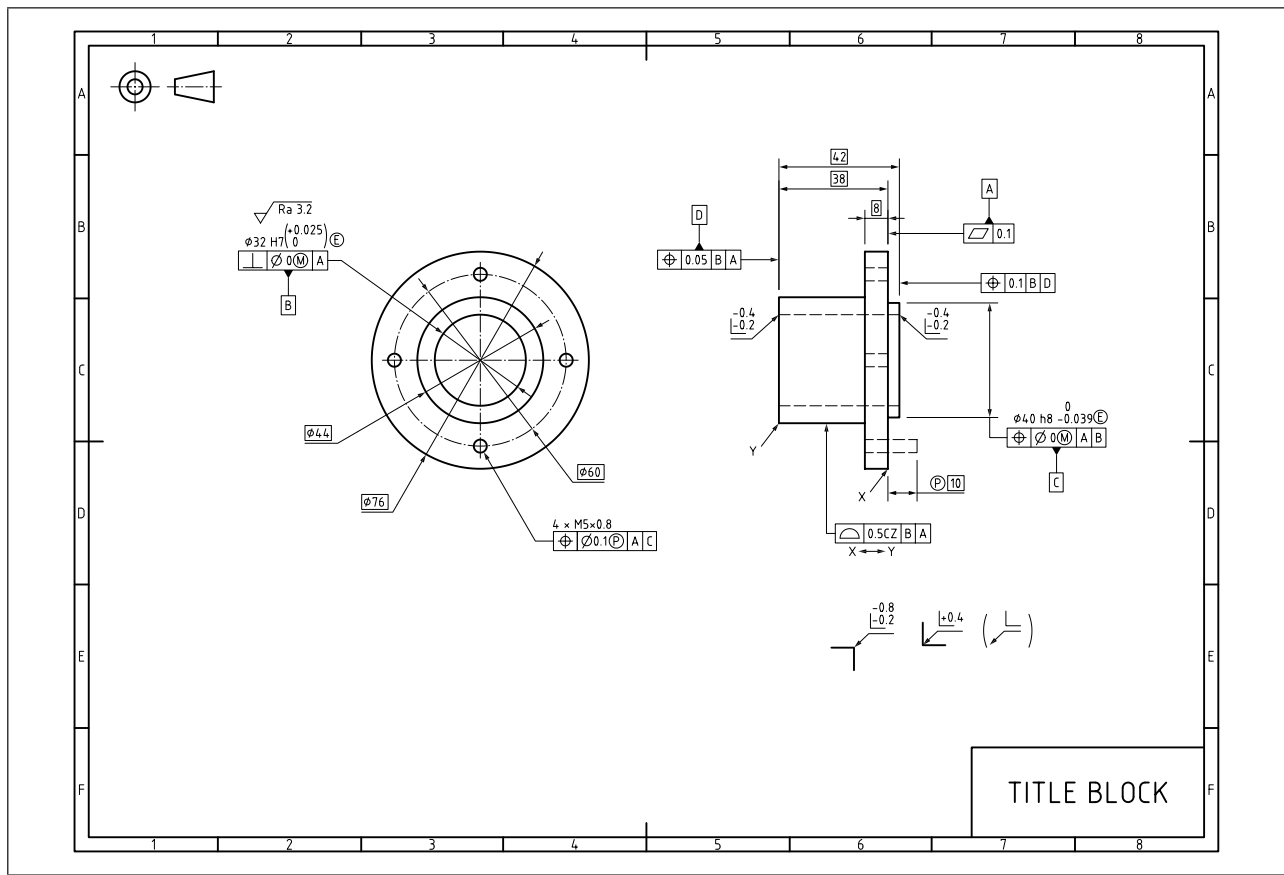
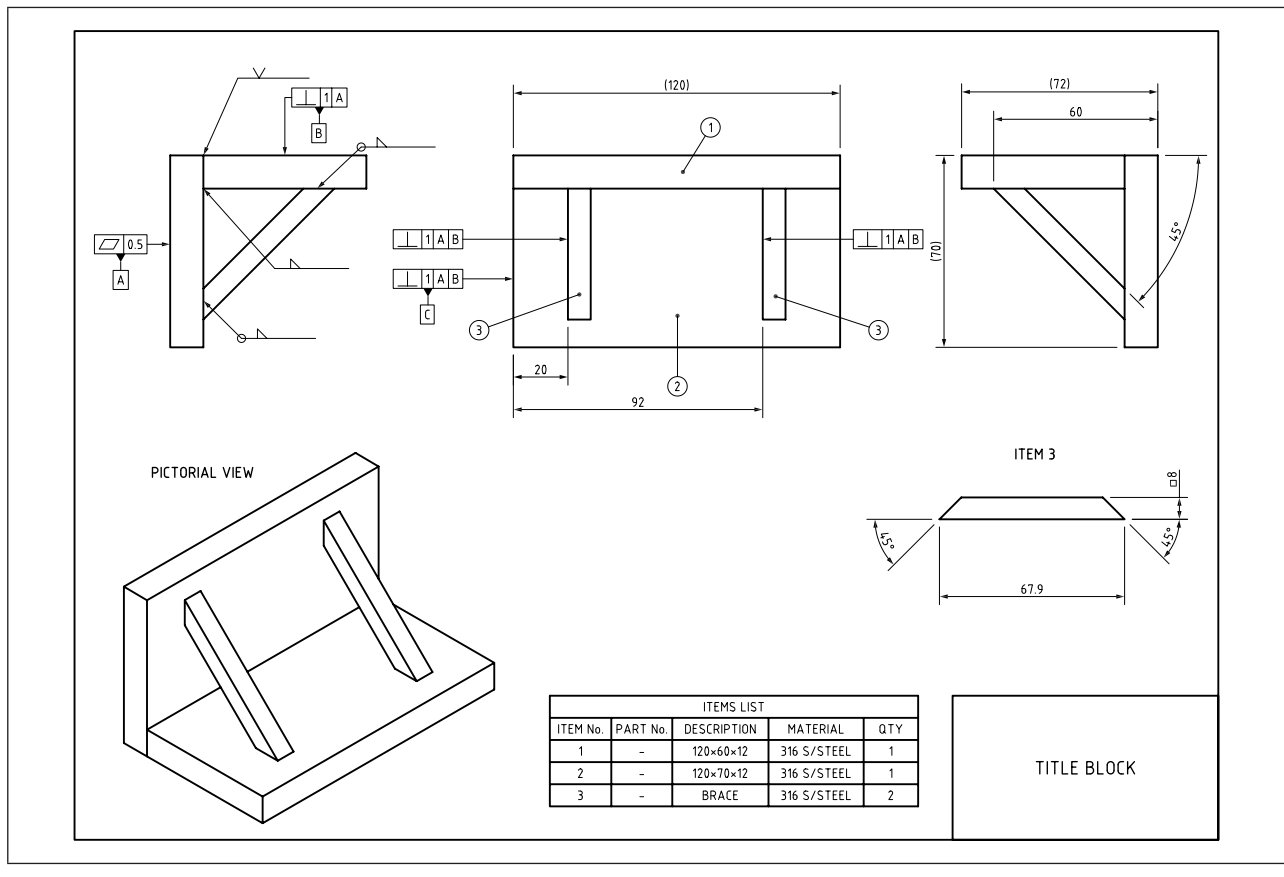


Figure 6 Example of fabrication drawing



## 4.1 Graphical representation and annotation of 3D data (3D modelling output)

Graphical representation and annotation of 3D models shall conform to the following standard.

BS ISO 16792, *Technical product documentation – Digital product definition data practices*

*NOTE* See Section 3.

## 4.2 Drawing sheets

*COMMENTARY ON 4.2*

*The complete drawing sheet comprises the drawing space, title block, border and frame.*

### 4.2.1 General

The drawing sheet shall conform to BS EN ISO 5457 and BS EN ISO 7200.

### 4.2.2 Sizes

As required by BS EN ISO 5457, the original drawing shall be made on the smallest sheet permitting the necessary clarity and resolution.

*NOTE 1* The preferred sizes of the trimmed and untrimmed sheets, as well as the drawing space, are given in Table 3.

*NOTE 2* The range of sheet sizes chosen could be rationalized through the use of scales. See 4.4.

Table 3 Sizes of trimmed and untrimmed sheets and the drawing space<sup>A)</sup>

Designation	Trimmed sheet (T)		Drawing space		Untrimmed sheet (U)	
	a <sub>1</sub> <sup>B)</sup>	b <sub>1</sub> <sup>B)</sup>	a <sub>2</sub> ±0,5	b <sub>2</sub> ±0,5	a <sub>3</sub> ±2	b <sub>3</sub> ±2
A0 <sup>C)</sup>	841	1 189	821	1 159	880	1 230
A1	594	841	574	811	625	880
A2	420	594	400	564	450	625
A3	297	420	277	390	330	450
A4 landscape	210	297	190	267	240	330
A4 portrait	297	210	277	180	330	240

<sup>A)</sup> Dimensions in millimetres.

<sup>B)</sup> For tolerances see BS EN ISO 216.

<sup>C)</sup> For sizes >A0 see BS EN ISO 216.

### 4.2.3 Graphical features

#### 4.2.3.1 Title block

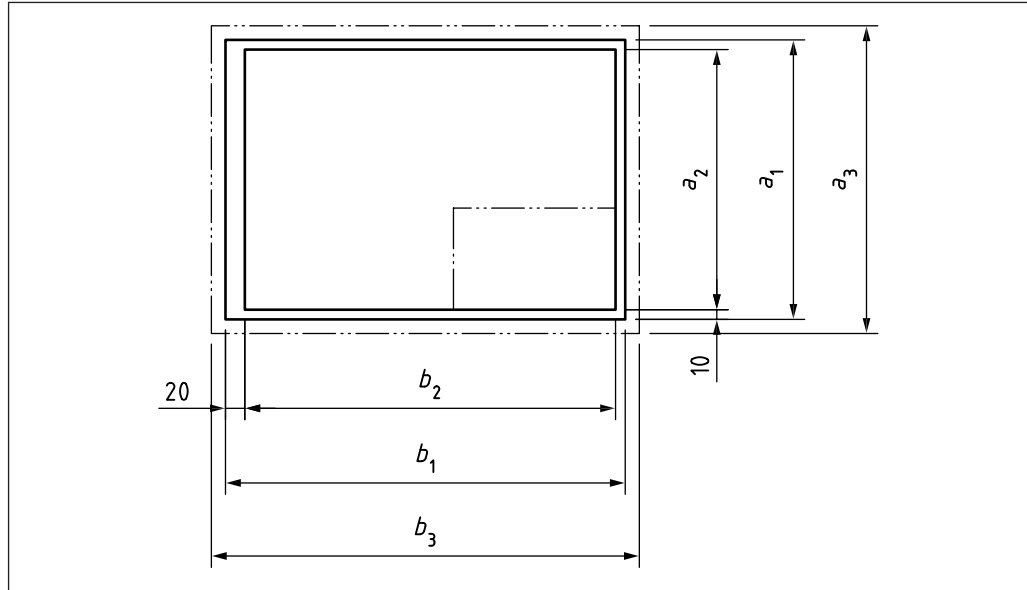
*NOTE 1* For the dimensions and layout of title blocks, see BS EN ISO 7200.

Sheet sizes A0 to A3 shall be used in landscape orientation only (see Figure 7) and the title block shall be located in the bottom right-hand corner of the drawing space.

*NOTE 2* A4 sheets can be used in landscape or portrait orientation.

For sheet size A4, the title block shall be situated in the bottom right-hand corner when used in landscape orientation, or the shorter (bottom) part of the drawing space when used in portrait orientation.

Figure 7 Size A4 to A0



The total width of the title block shall be 180 mm to fit an A4 portrait sheet where the left margin is 20 mm and the right margin 10 mm. The same title block shall be used for all paper sizes (see Figure 8).

*NOTE* In a TPS there is a minimum of eight mandatory data fields which may appear in the title block or elsewhere in the TPS or data management system (see Table 4).

Figure 8 Title block in compact form

Responsible dept. ABC 2	Technical reference Patricia Johnson	Document type Sub-assembly drawing	Document status Released			
Legal owner	Created by Jane Smith	Title, Supplementary title Apparatus plate	<b>AB123 456-7</b>			
	Approved by: David Brown	Complete with brackets				
			Rev. A	Date of issue 2002-05-14	Lang. en	Sheet 1/5
← 180 →						

Table 4 Identifying, descriptive and administrative data fields in the title block

Field name	Language-dependent	Recommended number of characters	Field type
Legal owner	–	Unspecified	Identifying
Identification number	No	16	Identifying
Date of issue	No	10	Identifying
Segment/sheet number	No	4	Identifying
Title	Yes	25/30 <sup>A)</sup>	Descriptive
Approval person	No/Yes <sup>B)</sup>	20	Administrative
Creator	No/Yes <sup>B)</sup>	20	Administrative
Document type	Yes	20	Administrative

<sup>A)</sup> 30 to support two-byte-character languages such as Japanese or Chinese.

<sup>B)</sup> "Yes" to support presentation in different types of alphabet.

#### 4.2.3.2 Borders and frame

Borders enclosed by the edges of the trimmed sheet and the frame limiting the drawing space shall be provided with all sizes. The border shall be 20 mm wide on the left edge, including the frame, and it can be used as a filing margin. All other borders shall be 10 mm wide.

The frame for limiting the drawing space shall be executed with continuous wide lines.

#### 4.2.3.3 Grid reference system

The sheets shall be divided into fields in order to permit easy location of details, additions, revisions, etc., on the drawing. The individual fields shall be referenced using capital letters (I and O shall not be used) in the left and right borders, and numerals in the top and bottom borders. For the size A4, they shall be located only at the top and the right side. The start of the ascending sequences of letters and numerals shall begin at the sheet origin, which can either be determined manually or defined by the CAD tool.

The size of letters and characters shall be 3.5 mm. The length of the fields shall be 50 mm, starting either at the sheet origin or from the centring mark.

*NOTE* The number of fields depends on sheet size (see Table 5).

The letters and numerals shall be placed in the grid reference border, and shall be written in vertical characters in accordance with BS EN ISO 3098-2.

The number of fields shall be extended as required for non-standard sheet sizes.

The grid reference system lines shall be executed with continuous narrow lines.

Table 5 Number of fields

Designation	A0	A1	A2	A3	A4
Long side	24	16	12	8	6
Short side	16	12	8	6	4

## 4.3 Line types and line widths



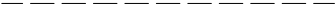




### 4.3.1 Types of line

Lines shall conform to BS EN ISO 128-20.

*NOTE 1* Examples of the most common line type and width combinations for engineering drawings are given in Table 6.

*NOTE 2* See BS EN ISO 128-20 and BS ISO 128-24 for more information on lines.

Table 6 Basic line types

No.	Representation	Description	Application
01.1		Continuous narrow line	Dimension lines, extension lines, leader lines, hatching, roots of screw threads, termination of interrupted views
01.2		Continuous wide line	Visible edges, visible outlines, crests of threads, limit of thread length, section arrows
02.1		Dashed narrow line	Hidden edges, hidden outlines
02.2		Dashed wide line	Permissible areas of surface treatment
04.1		Long dashed-dotted narrow line	Centre lines, lines and planes of symmetry, pitch circle of gears or holes, spread of surface-hardened areas
04.2		Long dashed-dotted wide line	Position of cutting planes, restricted area for surface treatment or application of tolerance requirement
05.1		Long dashed-double-dotted narrow line	Outline of adjacent parts, extreme positions of moveable parts, initial outline prior to forming, projected tolerance zones and outline of datum target areas

*NOTE* Example applications in the use of line types can be found in Figure 4 to Figure 6 and Figure 14 to Figure 17.

### 4.3.2 Line width

In accordance with BS EN ISO 128-20, the width,  $d$ , of all types of line shall be one of the following, depending on the type and size of drawing.

0,13 mm, 0,18 mm, 0,25 mm, 0,35 mm, 0,5 mm, 0,7 mm, 1 mm, 1,4 mm, 2 mm.

*NOTE 1* The widths of extra wide, wide and narrow lines are in the ratio 4:2:1.

*NOTE 2* For mechanical engineering drawings, two line thicknesses (typically 0,7 and 0,35 or 0,5 with 0,25) are sufficient for most purposes.

The line width of any one line shall be constant throughout the whole line (see also 4.7.2, Table 8).

### 4.3.3 Colours

According to the requirements of BS EN ISO 128-20, lines shall be drawn black or white depending on the background. Other standardized colours can also be used for drawing standardized lines and, in this case, the meaning of the colours shall be explained.

## 4.4 Scales

### COMMENTARY ON 4.4

*With the advent of CAD systems and the ability to view drawings electronically at any size, the importance of using a standard range of scales has greatly diminished.*

*Traditionally, the recommended scales for use on technical drawings were as set out in Table 7.*

Table 7 Scales

Category	Recommended scales		
Enlargement scales	50:1	20:1	10:1
	5:1	2:1	
<b>Full size</b>	1:1	1:1	1:1
Reduction scales	1:2	1:5	1:10
	1:20	1:50	1:100
	1:200	1:500	1:1 000
	1:2 000	1:5 000	1:10 000

The scale for a drawing shall be chosen according to the complexity of the object to be depicted and the purpose of the representation. In all cases, the selected scale shall be large enough to permit easy and clear interpretation of the information depicted. The scale and the size of the object, in turn, shall determine the size of the drawing. Where no scaleable views are presented, for example a chart drawing or item list, the term N/A ("Not applicable") shall be indicated in the title block scale field.

Details that are too small for complete dimensioning in the main representation shall be shown adjacent to the main representation in a separate detail view (or section) which is drawn to a larger scale.

3D models produced on CAD systems shall always be produced at 1:1.

*NOTE For more information on scales, see BS EN ISO 5455.*

## 4.5 Lines

### 4.5.1 Lines and terminators

Lines shall conform to the following standards, as appropriate.

- |                  |   |
|------------------|---|
| BS EN ISO 128-20 | <i>Technical drawings – General principles of presentation – Part 20: Basic conventions for lines</i>         |
| BS EN ISO 128-21 | <i>Technical drawings – General principles of presentation – Part 21: Preparation of lines by CAD systems</i> |

BS ISO 128-22	<i>Technical drawings – General principles of presentation – Part 22: Basic conventions and applications for leader lines and reference lines</i>
BS ISO 128-23	<i>Technical drawings – General principles of presentation – Part 23: Lines on construction drawings</i>
BS ISO 128-24	<i>Technical drawings – General principles of presentation – Part 24: Lines on mechanical engineering drawings</i>
BS ISO 128-25	<i>Technical drawings – General principles of presentation – Part 25: Lines on shipbuilding drawings</i>

#### 4.5.2 Lines, terminators and origin indicators

Arrows and terminators composed of lines shall conform to the following standard.

BS ISO 129-1	<i>Technical drawings – Indications of dimensions and tolerances – Part 1: General principles</i>
--------------	---

## 4.6 Number formats

### 4.6.1 General

Numbers used in dimensions and tolerances shall conform to 4.6.2. Where a “thousands” separator is required, a space shall be used; this can be used with metric and imperial numbers, and both before and after the decimal marker.

### 4.6.2 Metric values

The decimal marker shall be a comma.

Numbers smaller than 1 shall have a zero in front of the decimal marker:

e.g. 0,25 not ,25.

Non-indicated decimals shall be taken as zeros; i.e. 0,25 is the same as 0,250 000 000 000 000 .... and not rounded up to 0,25.

Trailing zeros shall be omitted:

e.g. 16 not 16,0.

***A note on imperial numbers:***

*ISO standards make no provision for the use of imperial units, so when they are used it is recommended that the American ASME Y14.5 [1] standard conventions are used. ASME Y14.5 [1] specifies the following requirements for imperial (inch) dimension and tolerance values:*

- *the decimal marker shall be a full stop;*
- *values smaller than 1 shall not have a zero in front of the decimal marker, e.g.:*  
*Ø.25 not Ø0.25;*
- *trailing zeros shall added where necessary, to ensure that the dimension and tolerance have the same number of decimal places, e.g.:*  
*.500±.005.*



## 4.7 Lettering

### 4.7.1 General

Lettering shall conform to the following standards, as appropriate.

- BS EN ISO 3098-0 *Technical Product Documentation – Lettering – Part 0: General requirements*<sup>4)</sup>
- BS EN ISO 3098-2 *Technical product documentation – Lettering – Part 2: Latin alphabet, numerals and marks*
- BS EN ISO 3098-3 *Technical product documentation – Lettering – Part 3: Greek alphabet*
- BS EN ISO 3098-4 *Technical product documentation – Lettering – Part 4: Diacritical and particular marks for the Latin alphabet*
- BS EN ISO 3098-5 *Technical product documentation – Lettering – Part 5: CAD lettering of the Latin alphabet, numerals and marks*
- BS EN ISO 3098-6 *Technical product documentation – Lettering – Part 6: Cyrillic alphabet*

### 4.7.2 Lettering size

Lettering heights and line widths shall be appropriate for the sheet size and method of reproduction.

*NOTE* Two types of lettering are described within BS EN ISO 3098-0<sup>4)</sup>, type A and type B. Upper case characters of type B have a height of 10 times the line width. Type A take the same character width as type B but with the height increased by a factor of  $\sqrt{2}$ . BS ISO 129-1 recommends the use of type B lettering. Preferred sizes are summarized in Table 8.

Table 8 Preferred line widths and lettering heights for drawing sheet sizes

Sheet size designation	A0	A1	A2	A3	A4
Line group (wide line)	0,7	0,7	0,7	0,5	0,5
Narrow line	0,35	0,35	0,35	0,25	0,25
Type B lettering height	3,5	3,5	3,5	2,5	2,5
Type B lower case height	2,5	2,5	2,5	1,75	1,75
Type B alternative height (line width)	5,0 (0,5)	5,0 (0,5)	5,0 (0,5)	3,5 (0,35)	3,5 (0,35)

### 4.7.3 Notes

Notes of a general nature shall, wherever practicable, be grouped together and not distributed over the drawing. Notes relating to specific details shall appear near the relevant feature, but not so near as to crowd the view.

Where emphasis is required, larger characters shall be used.

*NOTE* Underlining of notes is not recommended.

<sup>4)</sup> Withdrawn.

## 4.8 Projections

### 4.8.1 General

Projections shall conform to one of the following standards.

BS EN ISO 5456-2 *Technical drawings – Projection methods – Part 2: Orthographic representations*

BS EN ISO 5456-3 *Technical drawings – Projection methods – Part 3: Axonometric representations*

BS ISO 5456-4 *Technical drawings – Projection methods – Part 4: Central projection*

BS EN ISO 10209 *Technical product documentation – Vocabulary – Terms relating to technical drawings, product definition and related documentation*

*NOTE* BS EN ISO 5456-1 contains a survey of the various projection methods.

### 4.8.2 Conventions for arrangement of views on a TPD

#### 4.8.2.1 General

Three main conventions shall be used for arranging the views on a TPD:

- a) labelled views (see 4.8.2.3);
- b) first angle orthographic projection (see 4.8.2.4);
- c) third angle orthographic projection (see 4.8.2.5).

*NOTE 1* The order of this list is not meant to indicate a preference.

*NOTE 2* Other projection methods exist. See BS EN ISO 5456 (all parts).

#### 4.8.2.2 Choice of views

When views (including sections and sectional views) are needed, these shall be selected according to the following principles.

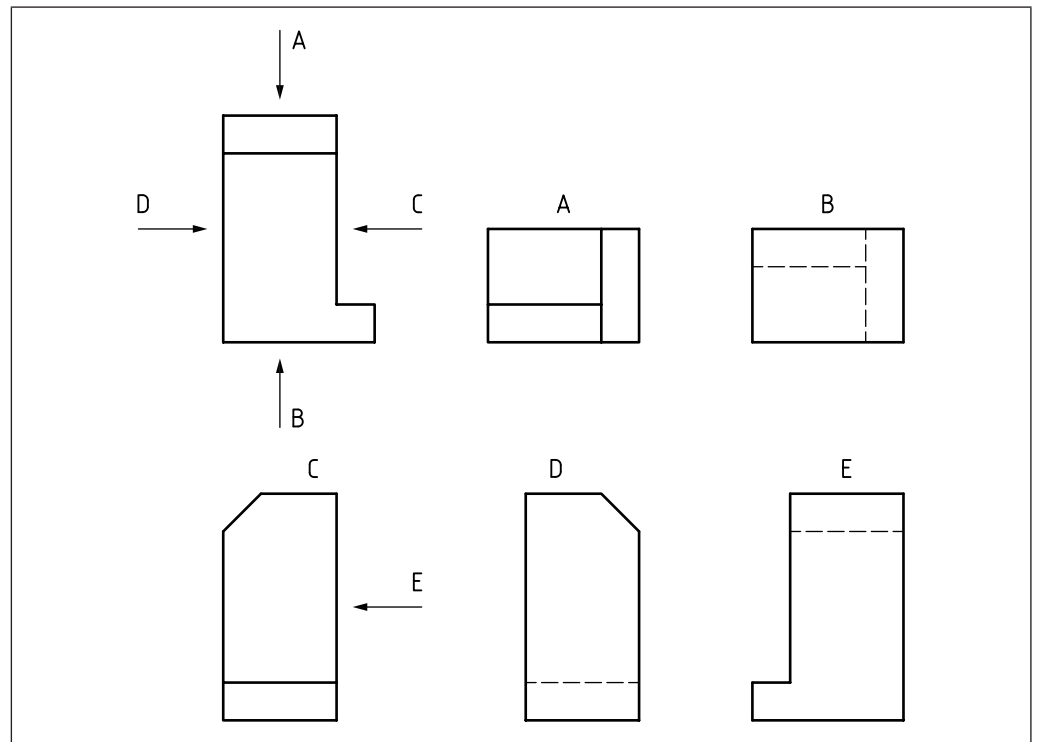
- a) The number of views (and sections and sectional views) shall be limited to the minimum necessary, but shall be sufficient to fully delineate the object without ambiguity.
- b) The need for hidden outlines and edges shall be avoided.
- c) The unnecessary repetition of a detail shall be avoided.

#### 4.8.2.3 Labelled view method

As required by BS ISO 128-30, the most informative view of an object shall be used as the front or principal figure, taking into consideration, for example, its functioning position, position of manufacturing or mounting. Each view, with the exception of the front or principal figure (view, plan, principal figure), shall be given clear identification with a capital letter, repeated near the reference arrow needed to indicate the direction of the viewing for the relevant view. Whatever the direction of viewing, the capital letter shall always be positioned in normal relation to the direction of reading, and be indicated either above or on the right side of the reference arrow.

The capital letters identifying the referenced views shall be placed immediately above the relevant views (see Figure 9).

Figure 9 Labelled view method



#### 4.8.2.4 First angle projection method

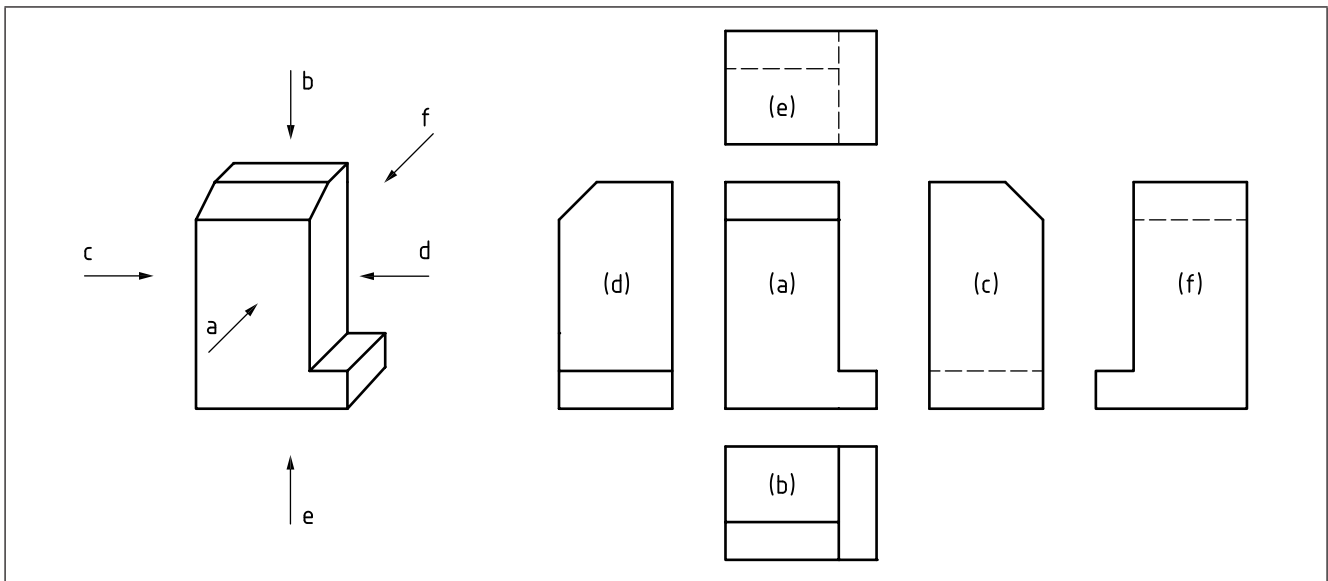
##### 4.8.2.4.1 General

*NOTE* A more detailed description of the first angle projection method is to be found in BS ISO 128-30 and BS EN ISO 5456-2.

With reference to the front view (a), the other views shall be arranged as follows (see Figure 10).

- The view from above (b) shall be placed underneath.
- The view from below (e) shall be placed above.
- The view from the left (c) shall be placed on the right.
- The view from the right (d) shall be placed on the left.
- The view from the rear (f) shall be placed on the left or right, as convenient.

Figure 10 First angle projection method

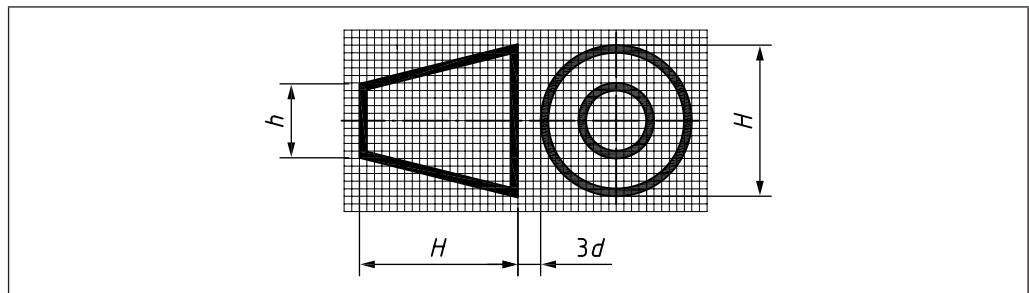


**4.8.2.4.2 First angle projection method – Graphical symbol**

As specified by BS ISO 128-30, the graphical symbol for the first angle projection method shall be as shown in Figure 11.

The proportions and dimensions of this graphical symbol shall be as specified in BS ISO 128-30.

Figure 11 First angle projection method: Graphical symbol



**4.8.2.5 Third angle projection method**

*COMMENTARY ON 4.8.2.5*

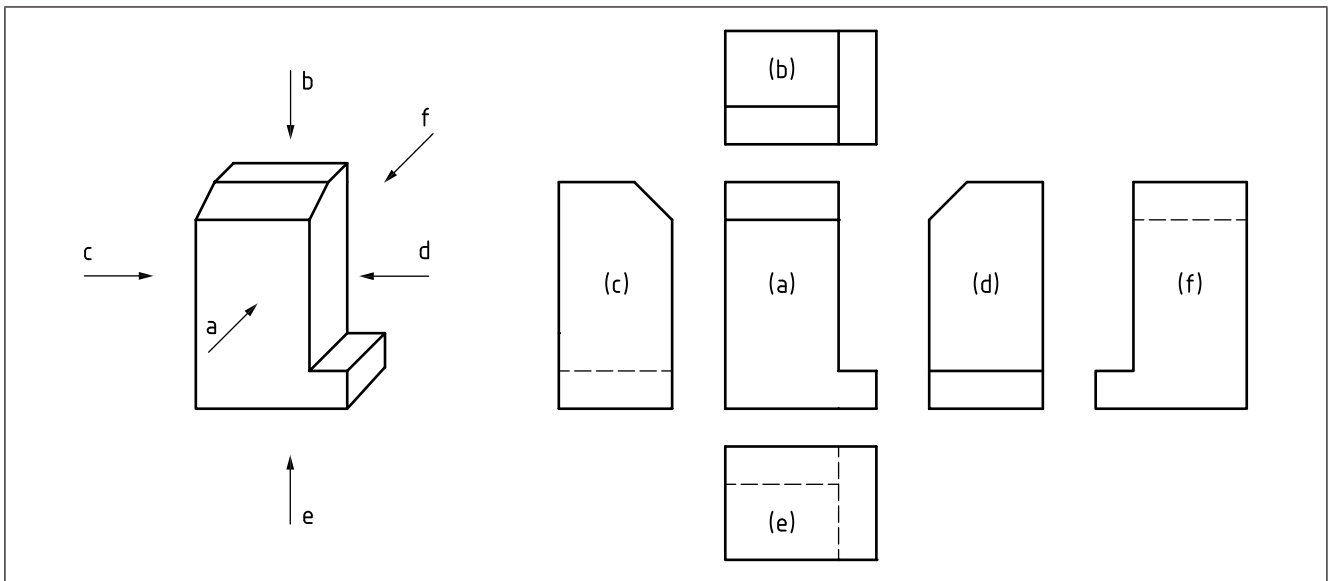
*A more detailed description of the third angle projection method is given in BS ISO 128-30 and BS EN ISO 5456-2.*

**4.8.2.5.1 General**

With reference to the front view (a), the other views shall be arranged as follows (see Figure 12).

- The view from above (b) shall be placed above.
- The view from below (e) shall be placed underneath.
- The view from the left (c) shall be placed on the left.
- The view from the right (d) shall be placed on the right.
- The view from the rear (f) shall be placed on the left or right, as convenient.

Figure 12 Third angle projection method

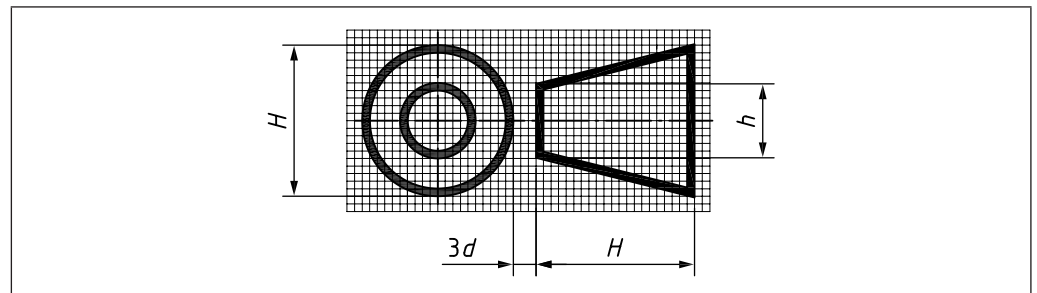


#### 4.8.2.5.2 Third angle projection method – Graphical symbol

As specified by BS ISO 128-30, the graphical symbol for the third angle projection method shall be as shown in Figure 13.

The proportions and dimensions of this graphical symbol shall be as specified in BS ISO 128-30.

Figure 13 Third angle projection method: Graphical symbol



## 4.9 Views

### 4.9.1 General

Views shall conform to the following standards.

BS ISO 128-30 *Technical drawings – General principles of presentation – Part 30: Basic conventions for views*

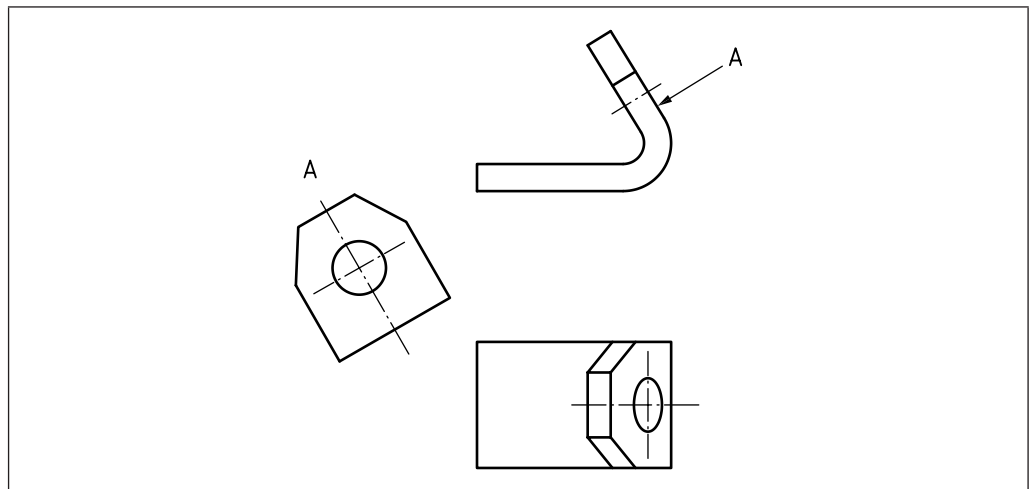
BS ISO 128-34 *Technical drawings – General principles of presentation – Part 34: Views on mechanical engineering drawings*

### 4.9.2 Auxiliary views

Where true representation of features is necessary, but cannot be achieved on the orthographic views, the features shall be shown in projected auxiliary views.

*NOTE* An example is shown in Figure 14.

Figure 14 Auxiliary view showing true shape of inclined surface



## 4.10 Sections

Sections shall conform to the following standards.

BS ISO 128-40 *Technical drawings – General principles of presentation – Part 40: Basic conventions for cuts and sections*

BS ISO 128-44 *Technical drawings – General principles of presentation – Part 44: Sections on mechanical engineering drawings*

BS ISO 128-50 *Technical drawings – General principles of presentation – Part 50: Basic conventions for representing areas on cuts and sections*

*NOTE* BS ISO 128-44 and BS ISO 128-50 contain presentational defects in some figures (e.g. line types, line thickness, terminators and letter heights). It is stressed that the text of these standards is technically correct and users should, therefore, regard the figures as illustrations only.

As specified by BS ISO 128-44, ribs, fasteners, shafts, spokes of wheels and the like shall not be cut in longitudinal sectional views, and shall therefore not be represented as sections.

*NOTE 1* In practice, it is not normally possible to avoid cutting ribs and spokes of wheels.

*NOTE 2* Like views, sections might be shown in a position other than that indicated by the arrows for the direction of their viewing.

*NOTE 3* A section in one plane is shown in Figure 15.

*NOTE 4* A section in two parallel planes is shown in Figure 16.

*NOTE 5* A section in three contiguous planes is shown in Figure 17.

Figure 15 Section view in one plane

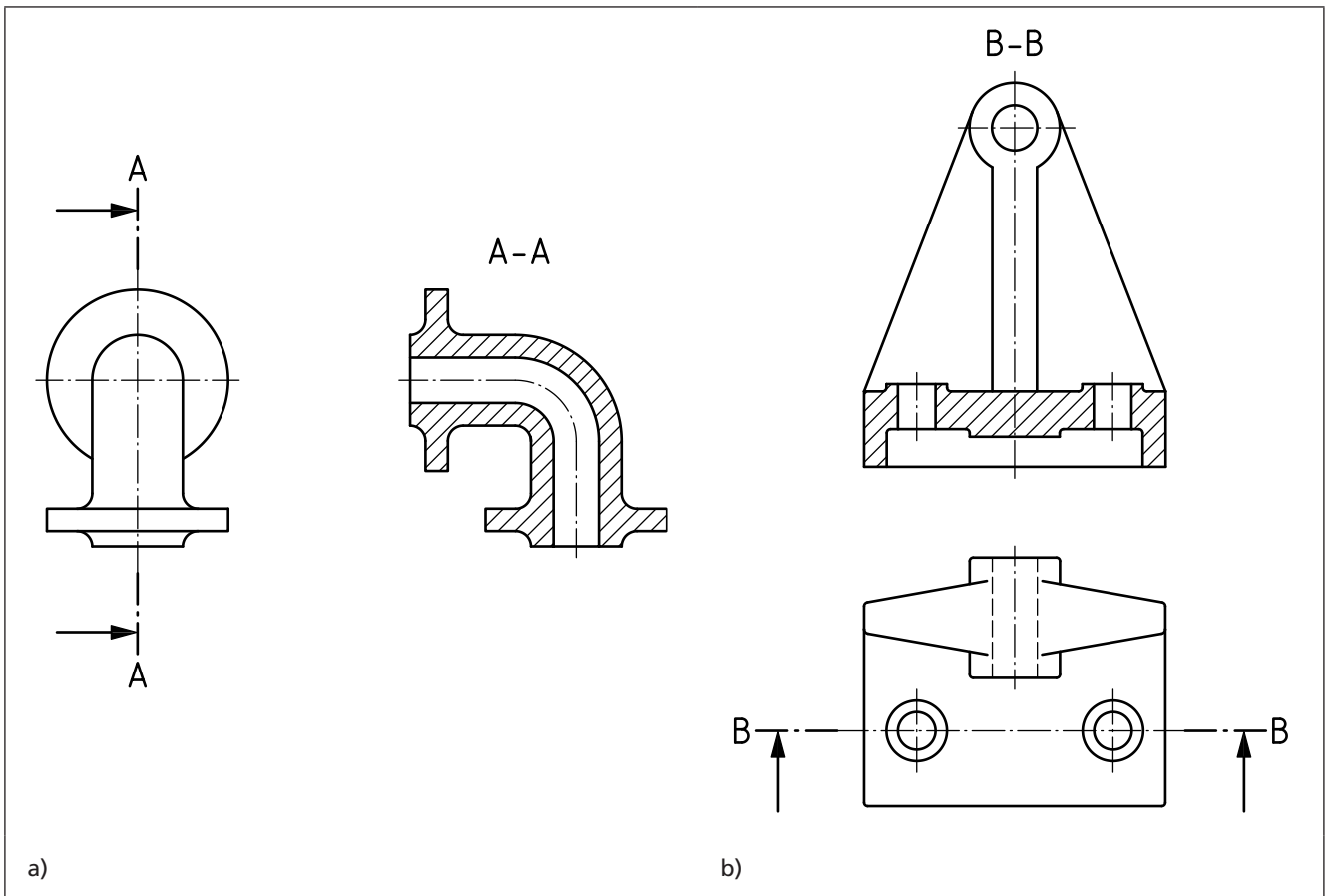


Figure 16 Section view in two parallel planes

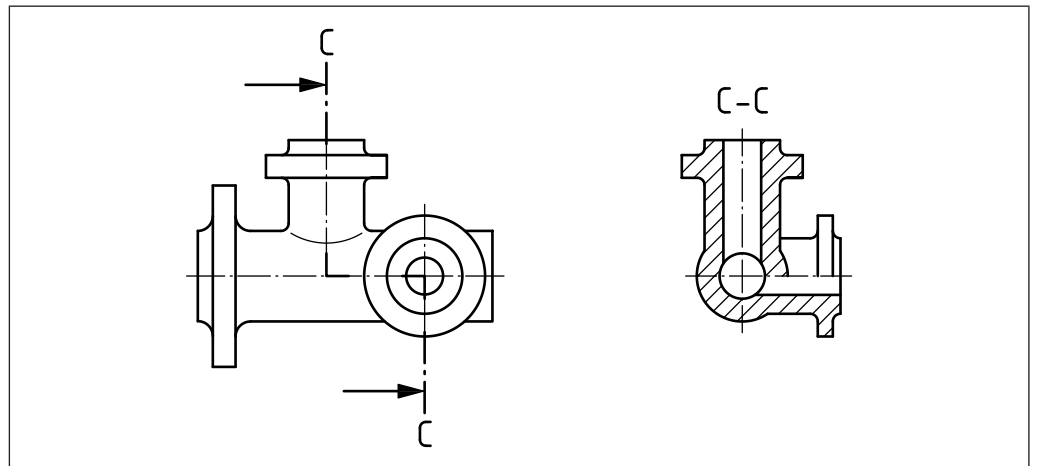
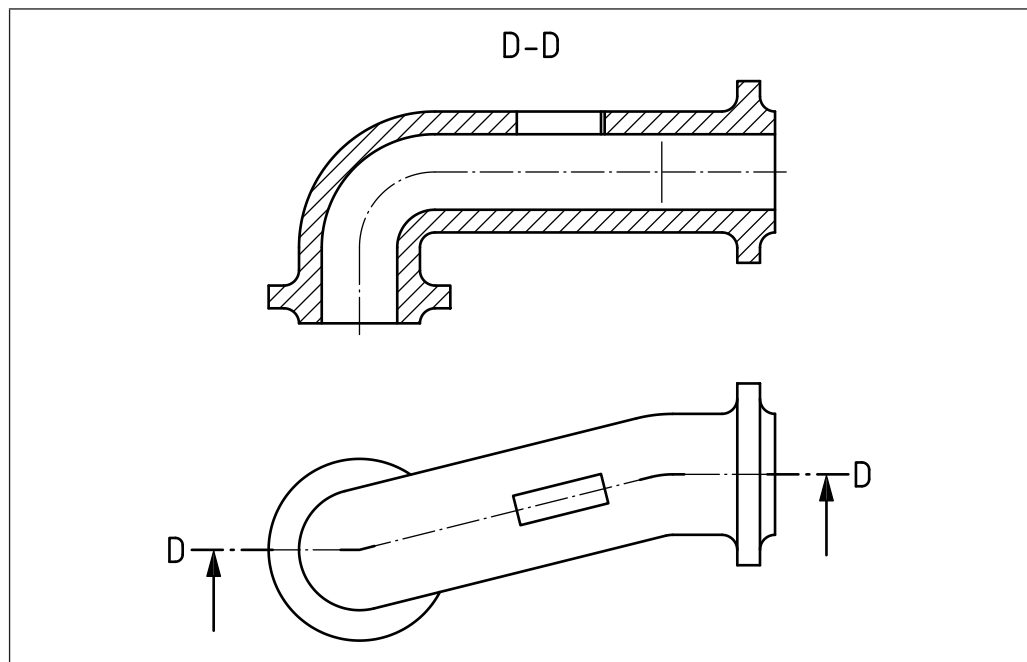


Figure 17 Section view in three contiguous planes showing true shape of inclined surface



## 4.11 Representation of components

### 4.11.1 General

Conventions used for the representation of components shall conform to the following standards, as appropriate.

BS EN ISO 2162-1	<i>Technical product documentation – Springs – Part 1: Simplified representation</i>
BS EN ISO 2162-2	<i>Technical product documentation – Springs – Part 2: Presentation of data for cylindrical helical compression springs</i>
BS EN ISO 26909	<i>Springs – Vocabulary</i>
BS EN ISO 2203	<i>Technical drawings – Conventional representation of gears</i>
BS ISO 1219-1	<i>Fluid power systems and components – Graphical symbols and circuit diagrams – Part 1: Graphical symbols for conventional use and data-processing applications</i>
BS 3238-1	<i>Graphical symbols for components of servo-mechanisms – Part 1: Transducers and Magnetic Amplifiers</i>
BS 3238-2	<i>Graphical symbols for components of servo-mechanisms – Part 2: General Servo-mechanisms</i>
BS ISO 13715	<i>Technical drawings – Edges of unidentified shape – Vocabulary and indications</i>
BS EN ISO 2553	<i>Welded and allied processes – Symbolic representation on drawings – Welded joints</i>
BS EN ISO 4063	<i>Welding and allied processes – Nomenclature of processes and reference numbers</i>
BS EN ISO 5261	<i>Technical drawings – Simplified representation of bars and profile sections</i>



BS EN ISO 5845-1	<i>Technical drawings – Simplified representation of the assembly of parts with fasteners – Part 1: General principles</i>
BS EN ISO 6410-1	<i>Technical drawings – Screw threads and threaded parts – Part 1: General conventions</i>
BS EN ISO 6410-2	<i>Technical drawings – Screw threads and threaded parts – Part 2: Screw thread inserts</i>
BS EN ISO 6410-3	<i>Technical drawings – Screw threads and threaded parts – Part 3: Simplified representation</i>
BS EN ISO 6411	<i>Technical drawings – Simplified representation of centre holes</i>
BS EN ISO 6412-1	<i>Technical drawings – Simplified representation of pipelines – Part 1: General rules and orthogonal representation</i>
BS EN ISO 6412-2	<i>Technical drawings – Simplified representation of pipelines – Part 2: Isometric projection</i>
BS EN ISO 6412-3	<i>Technical drawings – Simplified representation of pipelines – Part 3: Terminal features of ventilation and drainage systems</i>
BS EN ISO 6413	<i>Technical drawings – Representation of splines and serrations</i>
BS EN ISO 8826-1	<i>Technical drawings – Roller bearings – Part 1: General simplified representation</i>
BS EN ISO 8826-2	<i>Technical drawings – Roller bearings – Part 2: Detailed simplified representation</i>
BS EN ISO 9222-1	<i>Technical drawings – Seals for dynamic application – Part 1: General simplified representation</i>
BS EN ISO 9222-2	<i>Technical drawings – Seals for dynamic application – Part 2: Detailed simplified representation</i>
BS EN ISO 15785	<i>Technical drawings – Symbolic presentation and indication of adhesive, fold and pressed joints</i>

*NOTE* The BS ISO 128 series of standards covers the general subject of component representation.

#### 4.11.2 Representation of moulded, cast and forged components

Dimensional tolerancing for metal and metal alloy castings shall conform to the following standards, as appropriate.

BS EN ISO 8062-1	<i>Geometrical product specifications (GPS) – Dimensional and geometrical tolerances for moulded parts – Part 1: Vocabulary</i>
PD CEN ISO/TS 8062-2	<i>Geometrical Product Specifications (GPS) – Dimensional and geometrical tolerances for moulded parts – Part 2: Rules</i>
BS EN ISO 8062-3	<i>Geometrical product specifications (GPS) – Dimensional and geometrical tolerances for moulded parts – Part 3: General dimensional and geometrical tolerances and machine allowances for casting</i>

#### 4.11.3 Representation of moulded components

Indications for parting lines, draft angles and other elements of moulded components shall conform to the following standard.

BS EN ISO 10135	<i>Geometrical product specifications (GPS) – Drawing indications for moulded parts in technical product documentation (TPD)</i>
-----------------	--

## Section 5: Technical product specification (TPS): Dimensioning

### 5.1 General

Dimensioning and tolerancing shall conform to the following standards, as appropriate.

BS ISO 129-1	<i>Technical drawings – Indications of dimensions and tolerances – Part 1: General principles</i>
BS EN ISO 14405-2	<i>Geometrical product specifications (GPS) – Dimensional tolerancing – Part 2: Dimensions other than linear sizes</i>
BS EN ISO 1119	<i>Geometrical product specifications (GPS) – Series of conical tapers and taper angles</i>
BS EN ISO 1660	<i>Technical drawings – Dimensioning and tolerancing of profiles</i>
BS 1916-1	<i>Limits and fits for engineering – Part 1: Guide to limits and tolerances</i>
BS 1916-2	<i>Limits and fits for engineering – Part 2: Guide to the selection of fits in BS 1916-1</i>
BS 1916-3	<i>Limits and fits for engineering – Part 3: Guide to tolerances, limits and fits for large diameters</i>
BS EN ISO 3040	<i>Geometrical product specifications (GPS) – Dimensioning and tolerancing – Cones</i>
BS 3734-1	<i>Rubber – Tolerances for products – Part 1: Dimensional tolerances<sup>5)</sup></i>
BS 4500	<i>Limits and fits – Guidance for system of cone (taper) fits and tolerances for cones from <math>C = 1:3</math> to <math>1:500</math>, lengths from 6 mm to 630 mm and diameters up to 500 mm</i>
BS EN ISO 5458	<i>Geometrical Product Specifications (GPS) – Geometrical tolerancing – Positional tolerancing</i>
BS EN ISO 6410-1	<i>Technical drawings – Screw threads and threaded parts – Part 1: General conventions</i>
BS 7010	<i>Code of practice for a system of tolerances for the dimensions of plastic mouldings</i>
BS EN ISO 7083	<i>Technical drawings – Symbols for geometrical tolerancing – Proportions and dimensions</i>
BS EN ISO 8015	<i>Geometrical product specifications (GPS) – Fundamentals – Concepts, principles and rules</i>
BS ISO 10579	<i>Geometrical product specifications (GPS) – Dimensioning and tolerancing – Non-rigid parts</i>
BS EN ISO 13920	<i>Welding – General tolerances for welded constructions – Dimensions for lengths and angles – Shape and position</i>
BS EN ISO 8062-1	<i>Geometrical product specifications (GPS) – Dimensional and geometrical tolerances for moulded parts – Part 1: Vocabulary</i>

---

<sup>5)</sup> Withdrawn.

PD CEN ISO/TS 8062-2	<i>Geometrical Product Specifications (GPS) – Dimensional and geometrical tolerances for moulded parts – Part 2: Rules</i>
BS EN ISO 8062-3	<i>Geometrical product specifications (GPS) – Dimensional and geometrical tolerances for moulded parts – Part 3: General dimensional and geometrical tolerances and machining allowances for castings</i>
BS EN ISO 286-1	<i>Geometrical product specifications (GPS) – ISO code system for tolerances on linear sizes – Part 1: Basis of tolerances, deviations and fits</i>
BS EN ISO 286-2	<i>Geometrical product specifications (GPS) – ISO code system for tolerances on linear sizes – Part 2: Tables of standard tolerance classes and limit deviations for holes and shafts</i>

## 5.2 Dimensioning methods

### 5.2.1 Presentation rules

**5.2.1.1** Dimensioning shall conform to BS ISO 129-1.

*NOTE* The dimensioning of mechanical engineering drawings are to be specified in BS ISO 129-2, which is currently in preparation, while the dimensioning of shipbuilding drawings is specified in BS ISO 129-4.

**5.2.1.2** Only the dimensions which are necessary to unambiguously define the nominal geometry of the product shall be specified.

*NOTE* The dimensions shown should be for the purposes of describing the function, production or verification of the product.

**5.2.1.3** Each feature or relation between features shall be dimensioned only once.

**5.2.1.4** Unless otherwise specified, dimensions shall be indicated for the finished state of the dimensioned feature.

*NOTE* However, it might be necessary to give additional dimensions at intermediate stages of production if they are shown on the same drawing (e.g. the size of a feature prior to carburizing and finishing).

**5.2.1.5** All dimensional information shall be complete and shown directly on a drawing or 3D model, unless this information is specified in related associated documentation.

**5.2.1.6** All dimensions, graphical symbols and annotations shall be indicated such that they can be read from the bottom or right-hand side (main reading directions) of the drawing. Dimensioning and annotations of 3D models shall be in accordance with BS ISO 16792.

*NOTE* Dimensions alone are not sufficient to define the requirements of a product.

**5.2.1.7** Dimension shall be used with other specification techniques as applicable, e.g. geometrical tolerancing or surface texture requirements.

**5.2.1.8** Lettering on drawings shall be in accordance with BS EN ISO 3098.

**5.2.1.9** There shall be only one lettering height for dimension and tolerance indication for a TPS.

**5.2.1.10** A space shall separate the elements of the dimension indicator.

*NOTE* The dimension value and the lower deviation should be at the same distance from the dimension line.

**5.2.1.11** All dimensions shall be toleranced, either via a general tolerance or by direct indication of tolerance or limit indications, except the following cases:

- a) MIN, see 5.4.3;
- b) MAX, see 5.4.3;
- c) auxiliary dimension, see 5.2.8;
- d) theoretically exact dimension (TED) (see 7.8).

## 5.2.2 Presentation of decimals

Dimensional values indicated in decimal notation shall use a comma as the decimal marker.

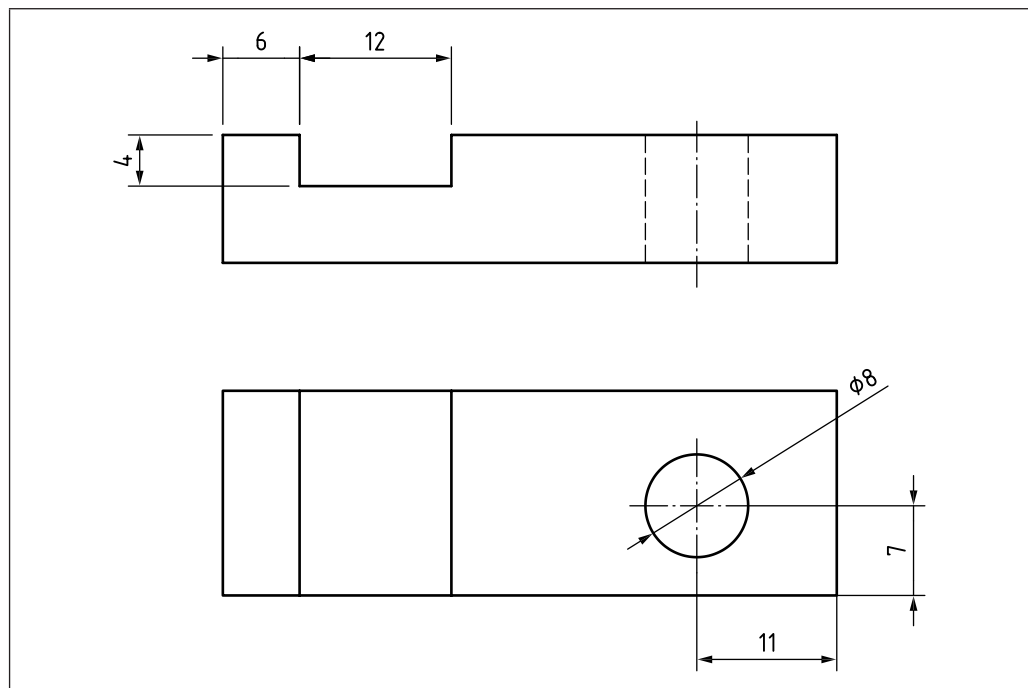
Each group of three digits, counting from the decimal marker to the left and to the right, shall be separated from other digits by a small space (e.g. 12 345,067 8).

*NOTE* The use of a comma or a point for this purpose is deprecated. It is further recommended that separation of items in lists be effected by the use of a semicolon.

## 5.2.3 Positioning of dimensions

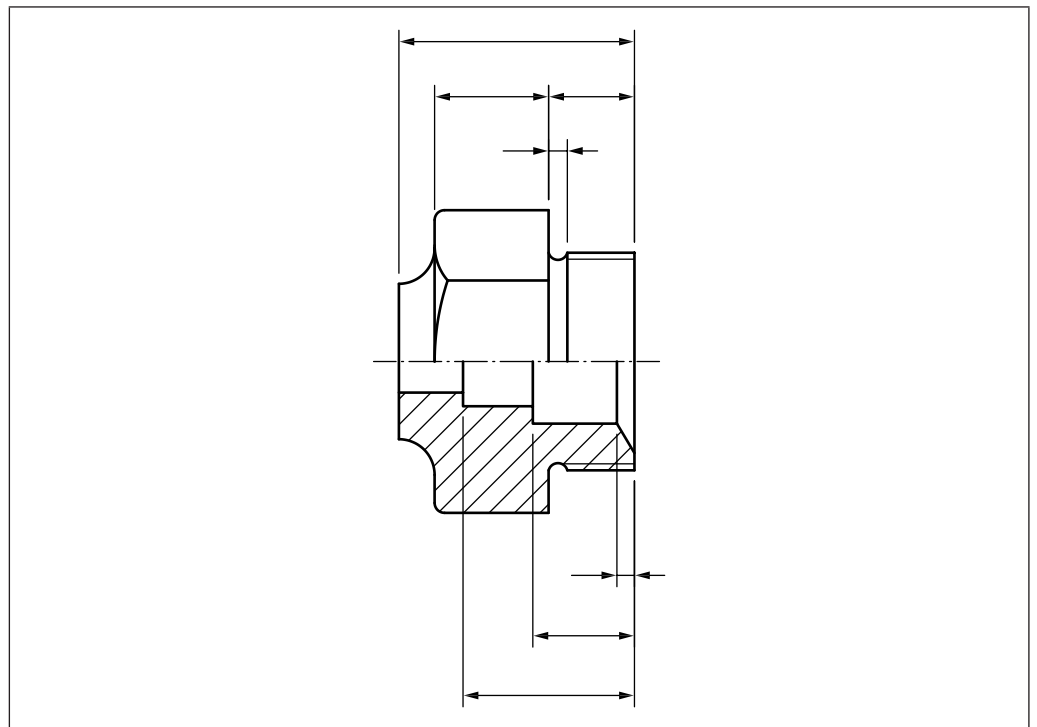
Dimensions shall be placed on that view or section which shows the relevant feature(s) most clearly (see Figure 18).

Figure 18 Positioning of dimensions



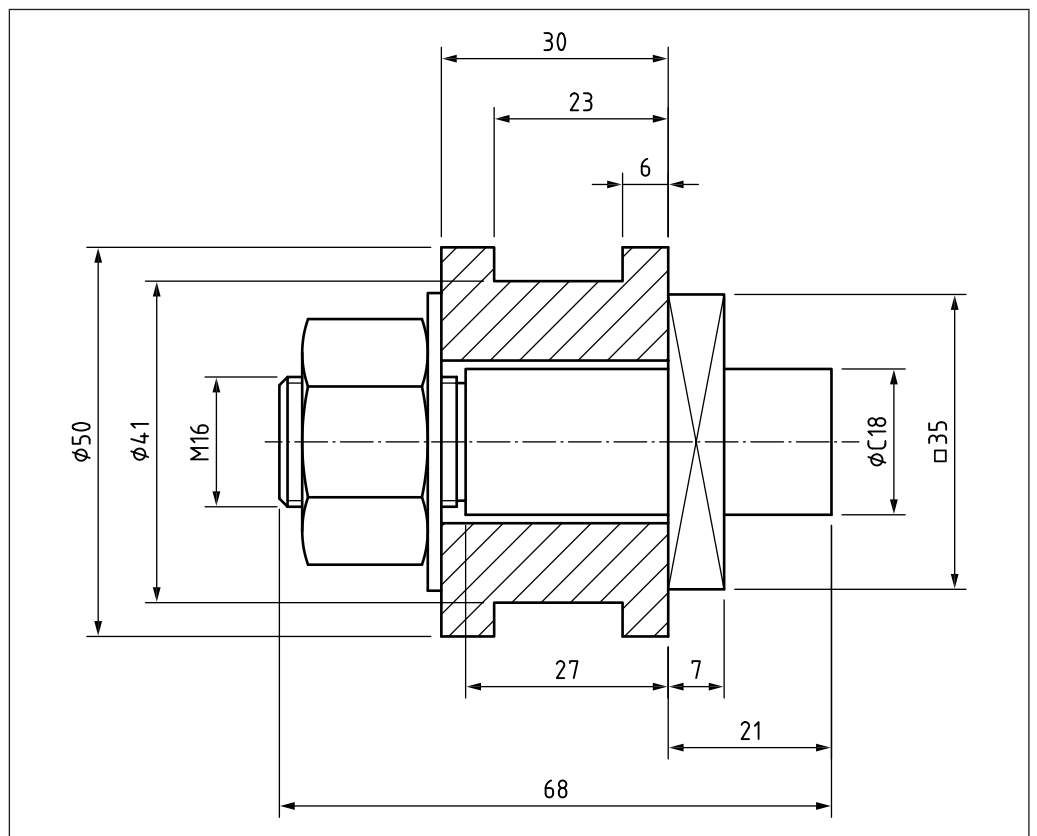
Dimensions for internal features and dimensions for external features shall, where possible, be arranged and indicated in separate groups of dimensions to improve readability (see Figure 19).

Figure 19 Arrangement and indication of dimensions internal and external features



Where several features or objects are depicted in close proximity, their relative dimensions shall be grouped together, separately, for ease of reading (see Figure 20).

Figure 20 Grouping of relative dimensions of features or objects in close proximity



Whenever possible, dimensions shall not be placed within the contour of the depicted item.

### 5.2.4 Units of dimensions

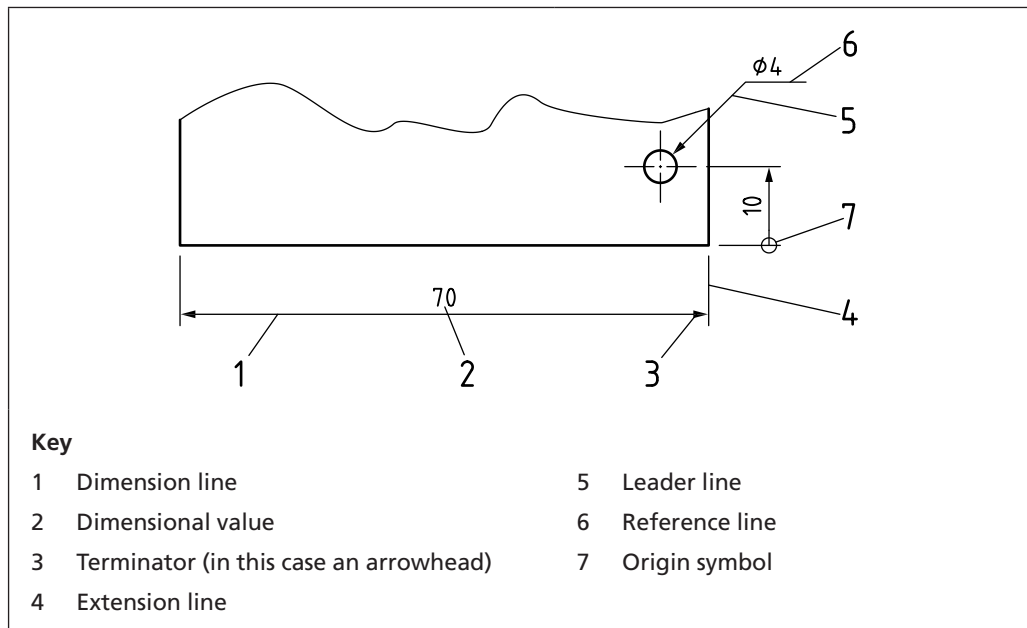
The units of a dimension shall be specified with the dimension. Typically, the predominant unit of measure on a drawing is specified in the drawing title block and the unit omitted from the individual dimensions. Any dimensions expressed in a different unit of measure shall indicate that unit of measure.

### 5.2.5 Elements of dimensioning: usage

#### 5.2.5.1 General

The various elements of dimensioning shall be indicated as illustrated in Figure 21.

Figure 21 Elements of dimensioning

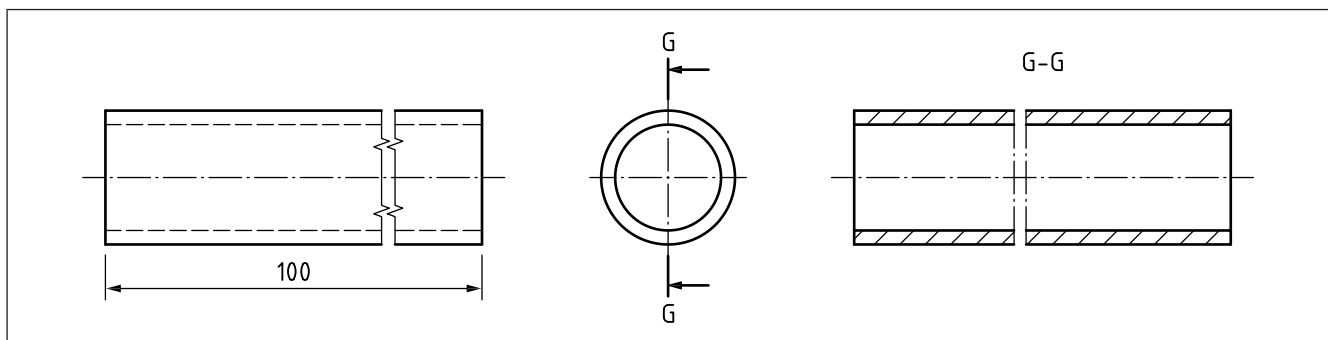


#### 5.2.5.2 Dimension line

Dimension lines shall be indicated as continuous narrow lines in accordance with BS EN ISO 128-20.

Where the feature is shown broken, the corresponding dimension line shall be shown unbroken (see Figure 22).

Figure 22 Dimension line of feature that is broken

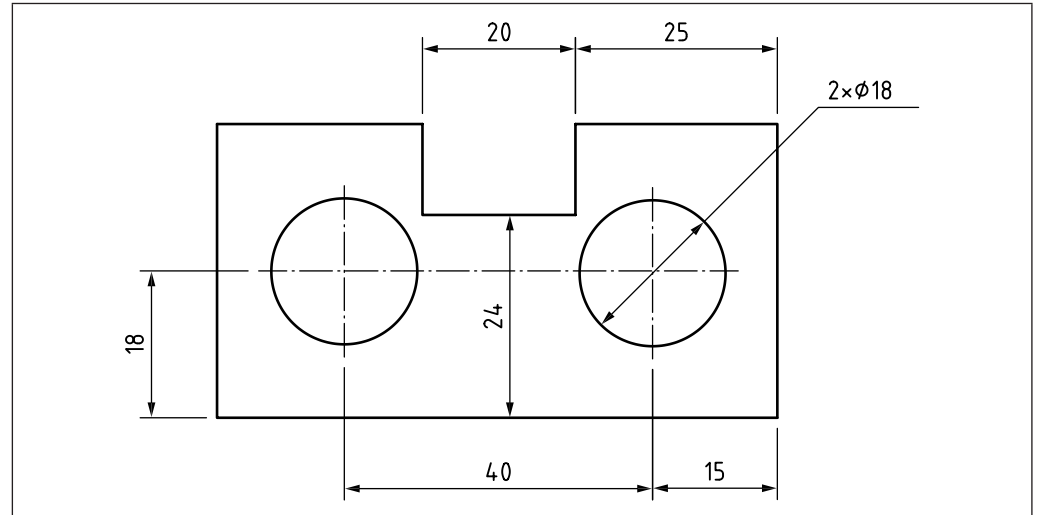


Dimension lines of holes can be indicated oblique through the centre of the hole (see Figure 23).

Intersection of dimension lines with any other line should be avoided, but where intersection is unavoidable they shall be shown unbroken (see Figure 20).

The centre line or outline of a feature or their extensions can be used in place of an extension line (see Figure 23). However, a centre line or the outline of a feature shall not be used as a dimension line.

Figure 23 Dimension lines of holes



### 5.2.5.3 Extension lines

Extension lines shall be drawn as continuous narrow lines in accordance with BS ISO 128-20.

Extension lines shall not be drawn between views and shall not be drawn parallel to the direction of hatching.

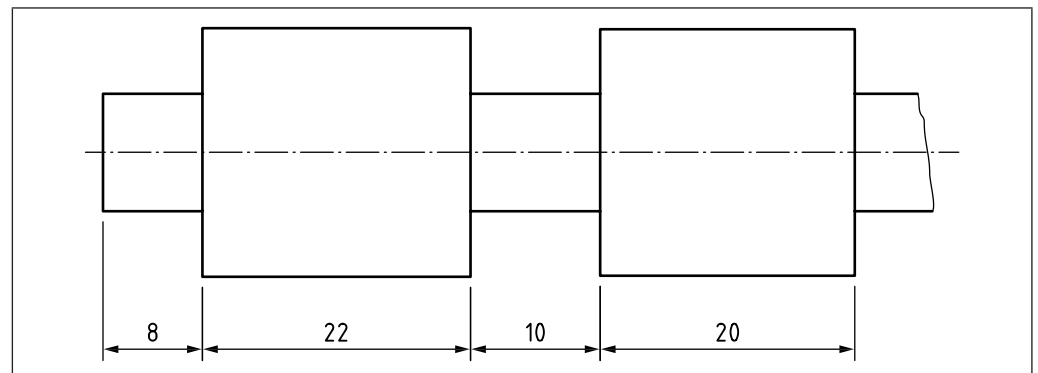
Extension lines shall extend approximately eight times the line width beyond their associated dimension line.

Extension lines should be drawn perpendicular to the corresponding physical length (see Figure 24, Figure 25 and Figure 26).

For circular features the extension line shall be drawn as a continuation of the feature shape (see Figure 62).

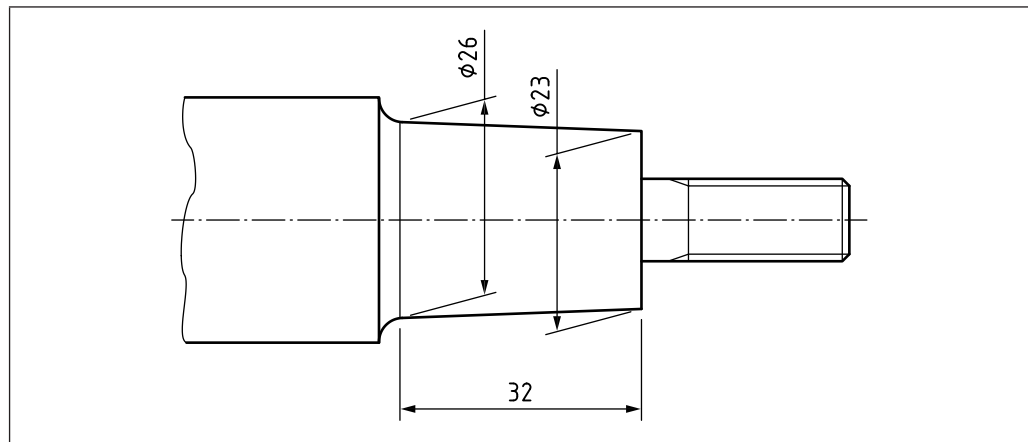
*NOTE* It is advisable to have a gap between the feature and the beginning of the extension line.

Figure 24 Extension lines



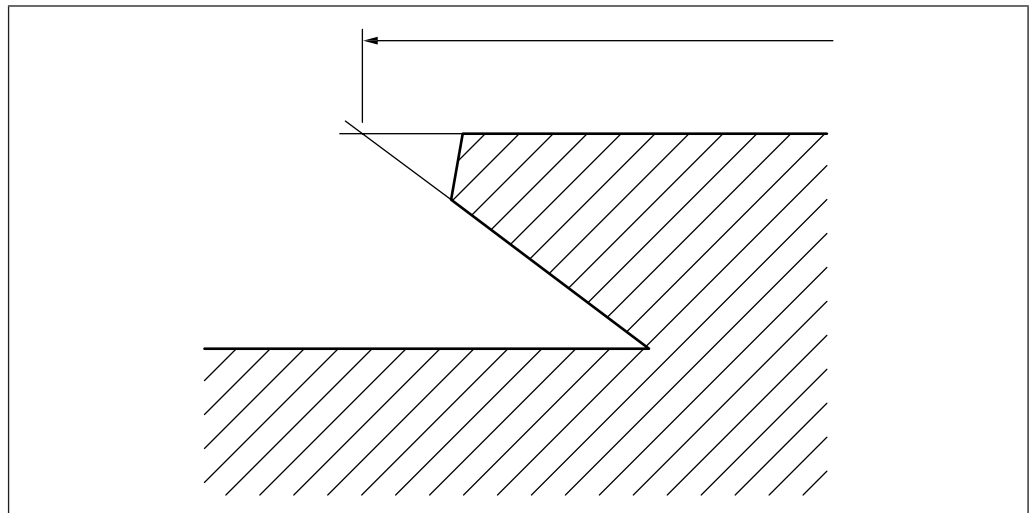
The extension lines may be drawn oblique to the feature but shall be parallel to each other (see Figure 25).

Figure 25 Oblique extension lines



Intersecting projected contours of outlines shall extend approximately eight times the line width beyond the point of intersection (see Figure 26).

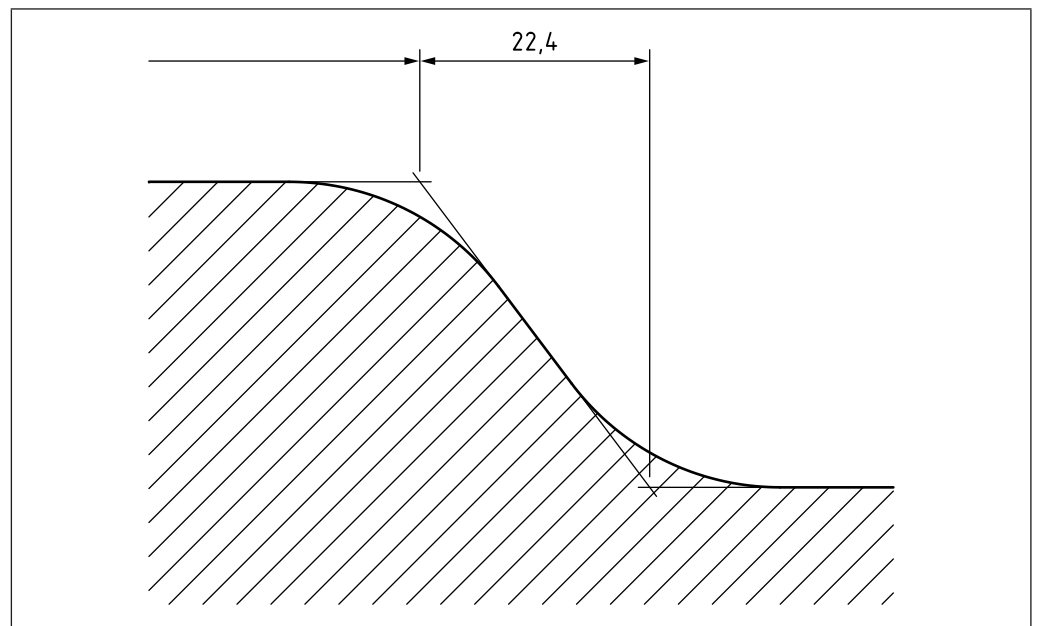
Figure 26 Intersection of projected contours of outlines



In the case of projected contours of transitions and similar features, the extension lines shall apply at the point of intersection of the projection lines (see Figure 27).

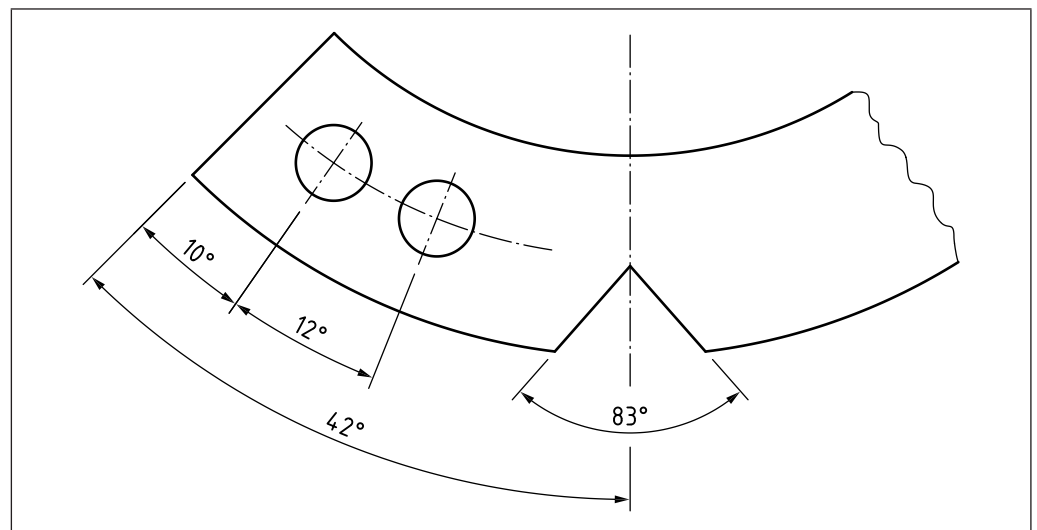


Figure 27 Intersection of projected contours of transitions and similar features



In the case of angular dimensions, the extension lines shall be the extensions of the angle legs (see Figure 28).

Figure 28 Extension lines of angular dimensions



#### 5.2.5.4 Leader line

Leader lines shall be drawn in accordance with BS ISO 128-22.

#### 5.2.6 Dimensional values

##### 5.2.6.1 Indication

Dimensional values shall be indicated on drawings in characters of sufficient size to ensure complete legibility on the original drawing, as well as on reproductions made from microfilms (see BS EN ISO 6428).

*NOTE* Lettering ISO 3098-BVL (Type B, Vertical, Latin) is recommended.

### 5.2.6.2 Positions of dimensional values

Dimensional values shall be placed parallel to their dimension line and near the middle of and slightly above that line (see Figure 29 and Figure 30).

Dimensional values shall be placed in such a way that they are not crossed or separated by any line.

Figure 29 Position of dimensional values

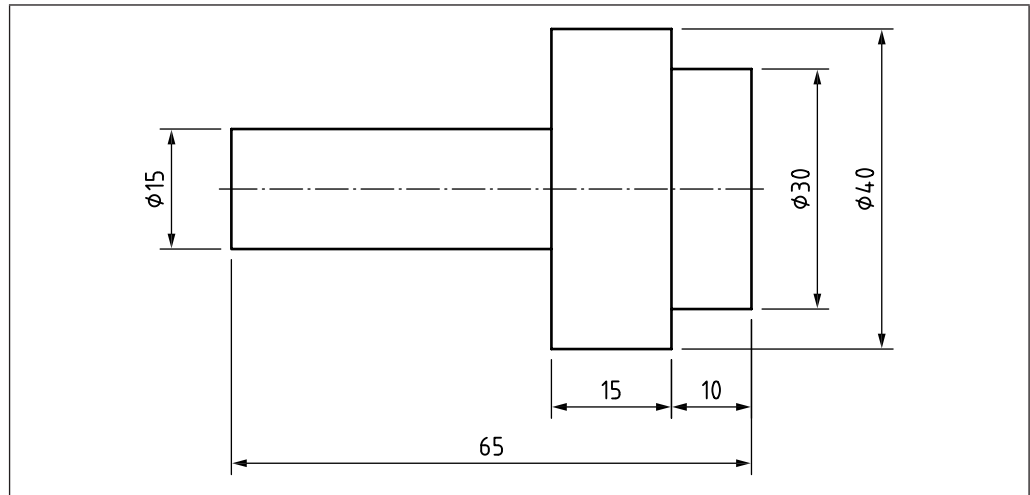
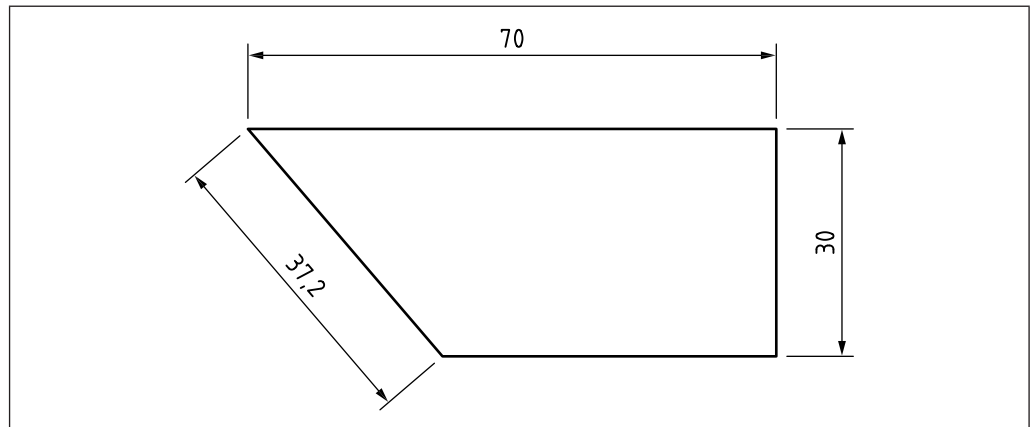


Figure 30 Position of dimensional values



Values of linear dimensions on oblique dimension lines shall be oriented as shown in Figure 31. The values shall be indicated so that they can be read from the bottom or right-hand side of the drawing.

Values of angular dimensions shall be oriented as shown in Figure 32. Angular dimensions shall be placed on top of the dimension line and follow the same rule as linear dimensions (see Figure 31).

Figure 31 Orientation of linear dimensions

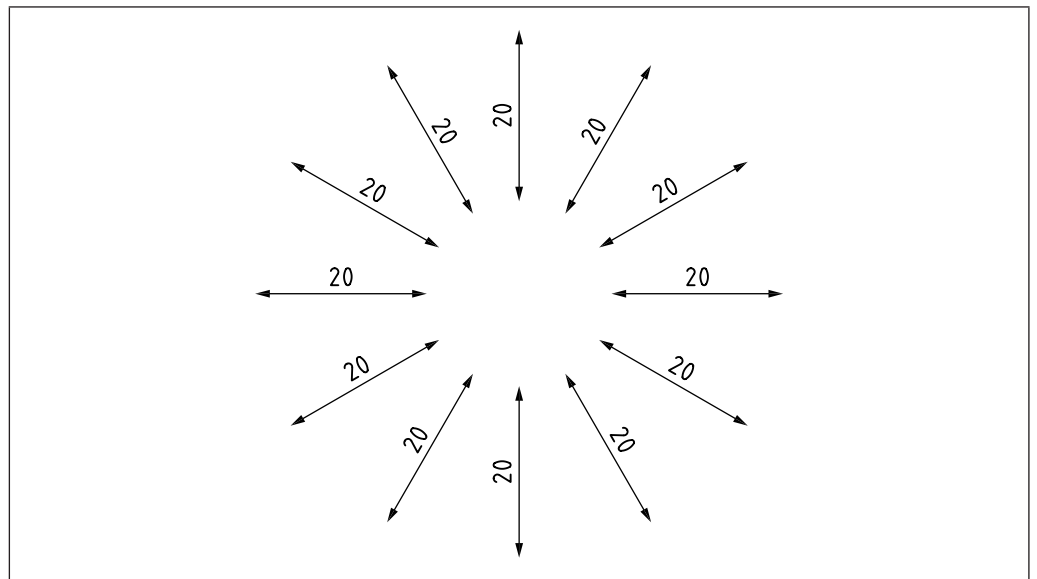
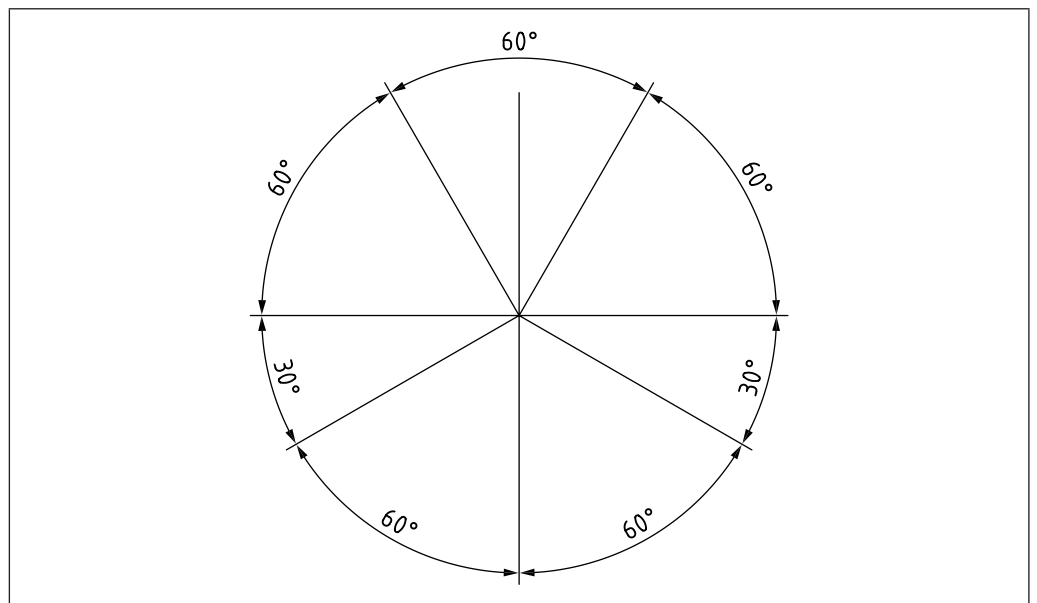


Figure 32 Orientation of angular dimensions



### 5.2.7 Indications of special dimensions

The following symbols shall be used with dimensions to identify the feature characteristics. The following symbols shall directly precede the dimensional value without space (see Figure 33 to Figure 37).

- $\phi$  Diameter
- R Radius
- $\square$  Square
- $S\phi$  Spherical diameter
- SR Spherical radius
- $\frown$  Arc length



- $t =$  Thickness of thin objects
- $\Downarrow$  Depth
-  Cylindrical counterbore
-  Countersink

Figure 33 Indications of special dimensions: Radius

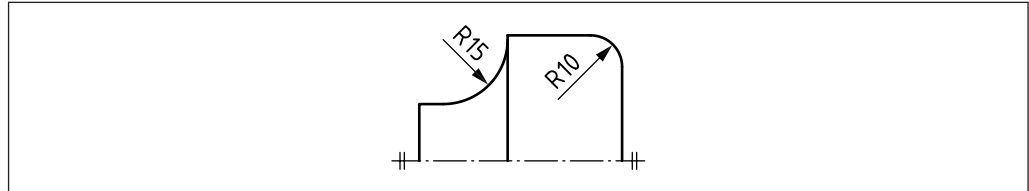


Figure 34 Indications of special dimensions: Square

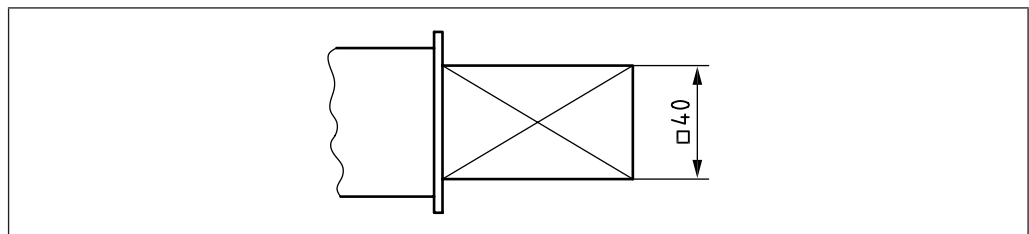


Figure 35 Indications of special dimensions: Spherical diameter

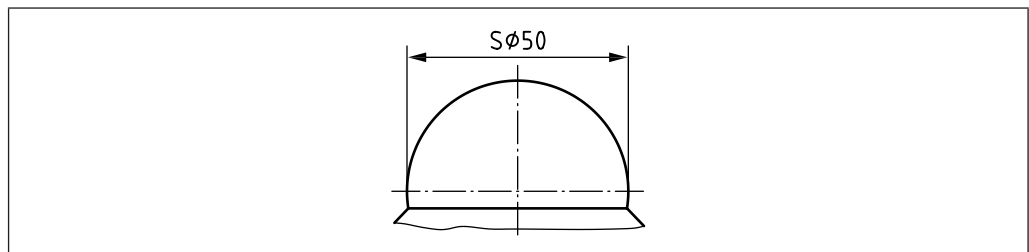


Figure 36 Indications of special dimensions: Spherical radius

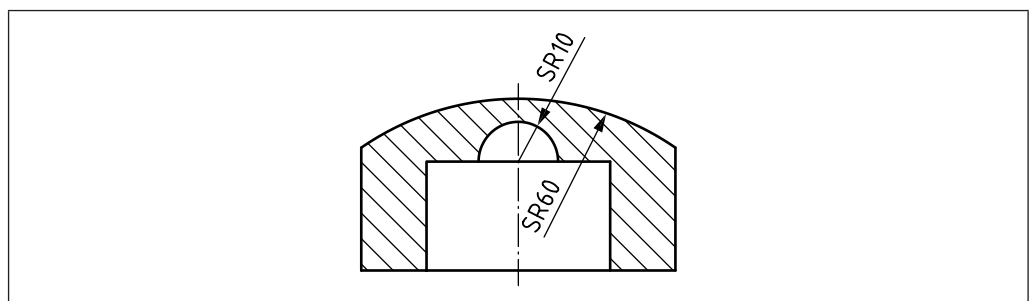
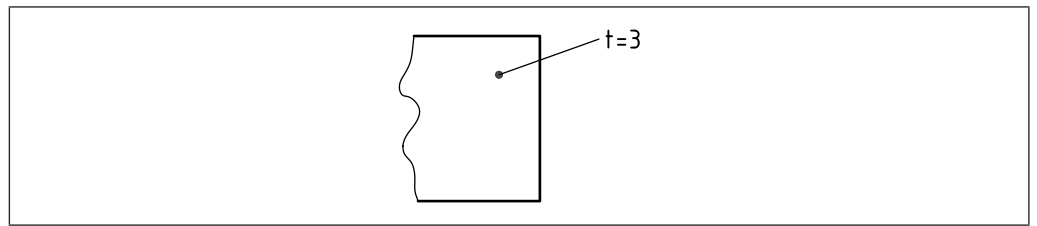


Figure 37 Indications of special dimensions: Thickness



When counterbore is indicated, the diameter, and depth if needed, of the counterbore shall be specified below the dimension value of the hole (see Figure 38). When countersink is indicated, the size and inclusive angle of the countersink shall be specified below the dimensional value of the hole (see Figure 39).

Figure 38 Diameter and depth of counterbore

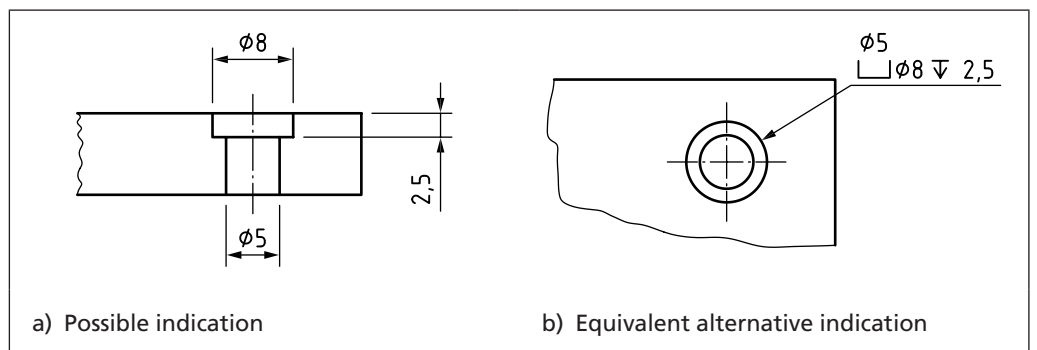
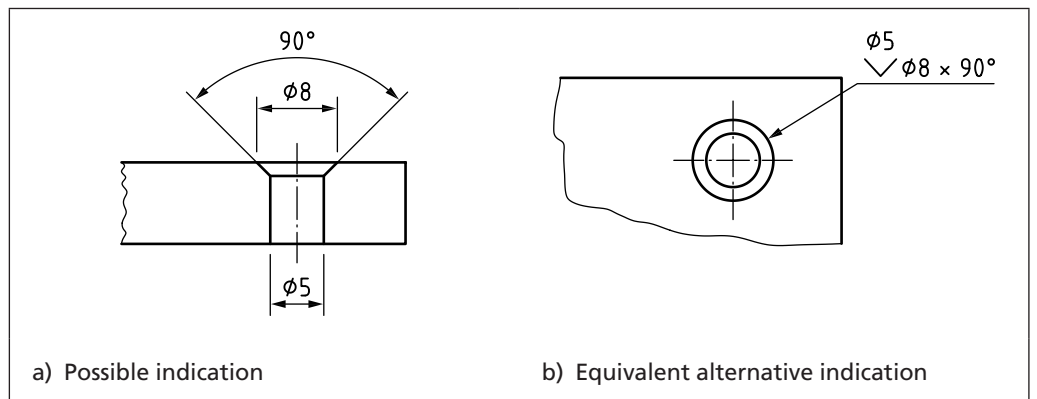


Figure 39 Size and angle of countersink



### 5.2.8 Auxiliary dimensions

Auxiliary dimensions shall be indicated within parentheses and do not constitute an integral part of the specification or requirement (see Figure 40 and Figure 41).

*NOTE Auxiliary dimensions in drawings are for information only and not for manufacturing and verification purposes. Auxiliary dimensions should have limited use.*

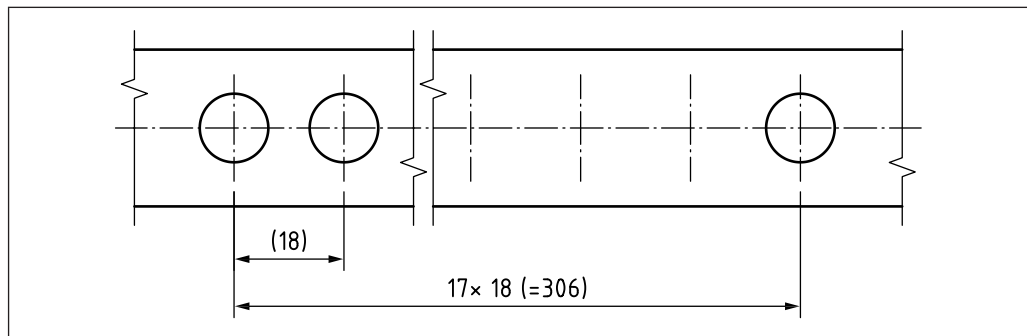
## 5.2.9 Equally-spaced and repeated features

### 5.2.9.1 Equally-spaced features

Where features have the same spacing and are uniformly arranged, their dimensioning shall, where appropriate, be simplified as follows.

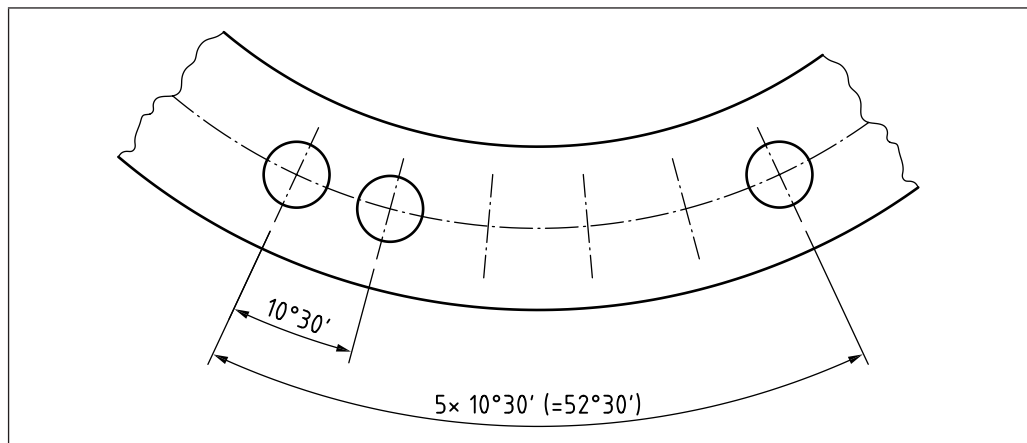
- Repeated linear and angular spacing can be indicated with the number of spacings and their dimensional value separated by the symbol "x". The number of features shall directly precede the symbol "x" without a space and the dimensional value shall be preceded by a space, e.g. 17x 18. If there is any risk of confusion between the length of the space and the number of spacings, one space may additionally be dimensioned (see Figure 40).
- The sum of the linear or angular spacing of the indicated features is an auxiliary dimension (see 5.2.8 and Figure 41 and Figure 42). The total representation shall be indicated as the number of spacings times the dimensional value of the spacings, and the sum given in parenthesis preceded by the equal sign.

Figure 40 Number of equally-spaced features and the dimensional value



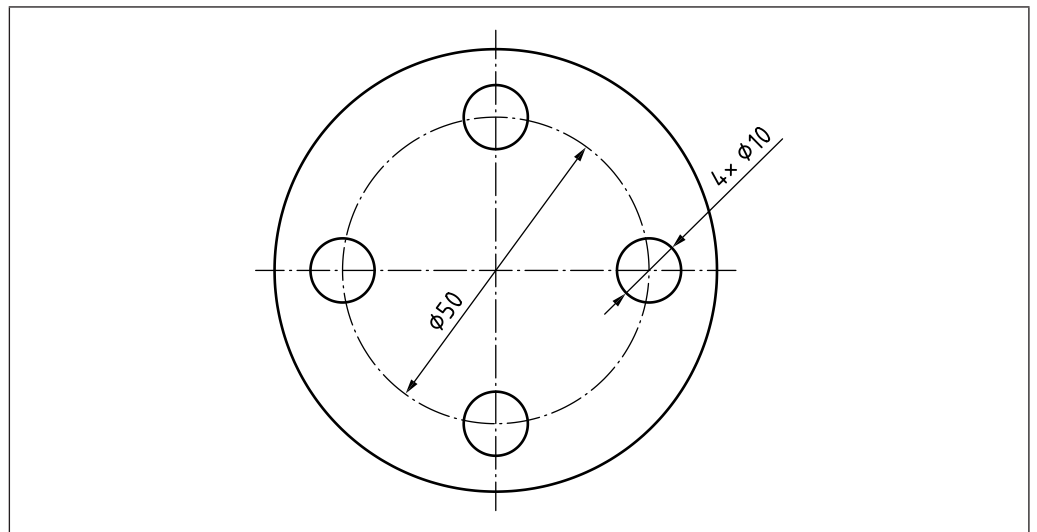
- Angular spacing can be dimensioned as shown in Figure 41.

Figure 41 Dimensioning of angular spacing



- The angles of the spacings can be omitted where spacings are self-evident and the indication does not lead to confusion (see Figure 42).

Figure 42 Angles of spacings



### 5.2.9.2 Repeated features

Where clarity is not impaired, features having the same dimensional value shall be indicated by that value preceded by the number of features and the symbol "x" (see Figure 43 and Figure 44).

Figure 43 Indication of features having the same dimensional value

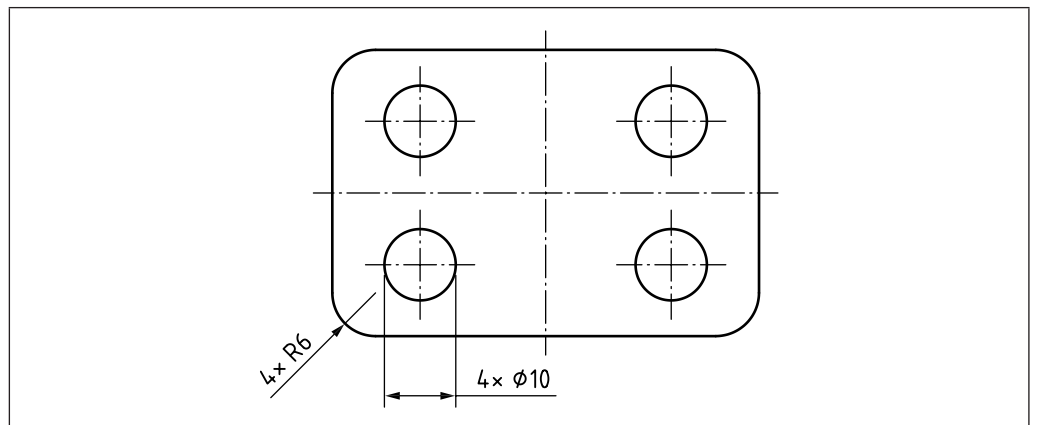
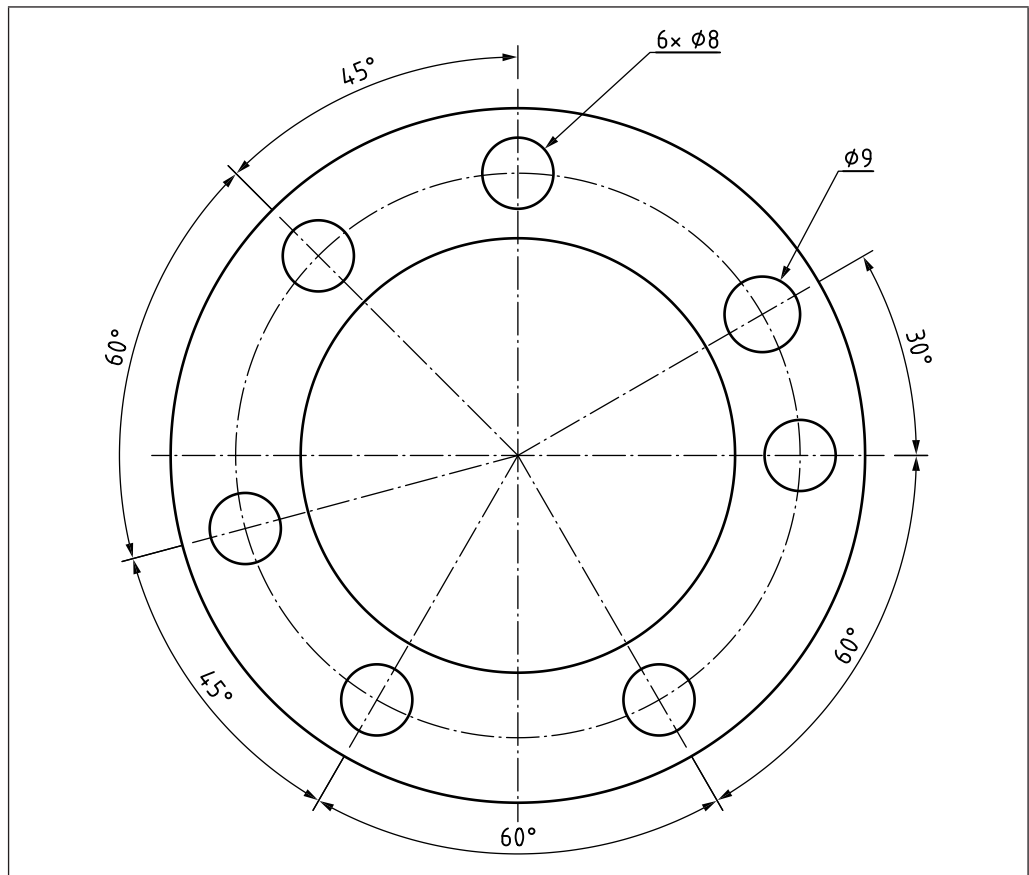


Figure 44 Indication of features having the same dimensional value

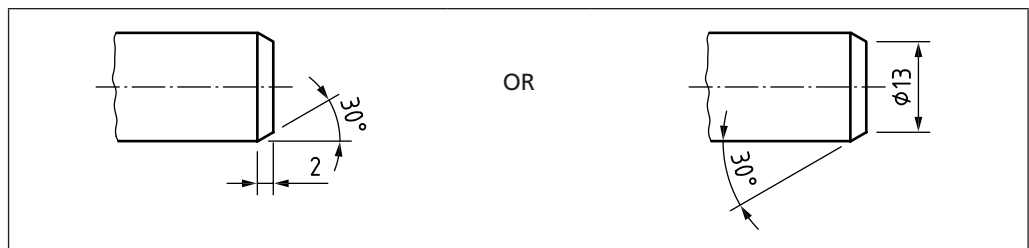


5.2.10 Chamfers

5.2.10.1 External chamfer

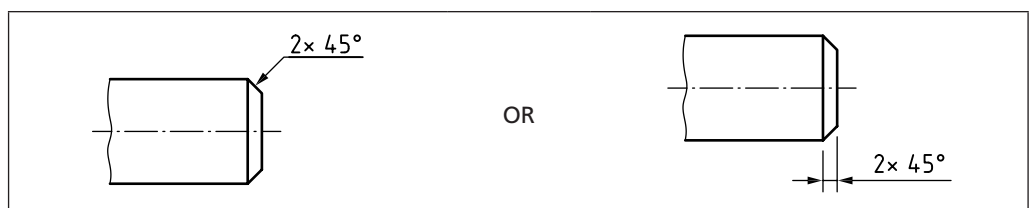
An external chamfer shall be dimensioned conventionally if the angle of the chamfer is not equal to 45° (see Figure 45).

Figure 45 Dimension of external chamfer not equal to 45°



If the chamfer angle is 45°, the indication can be simplified (see Figure 46).

Figure 46 Dimension of external chamfer equal to 45°

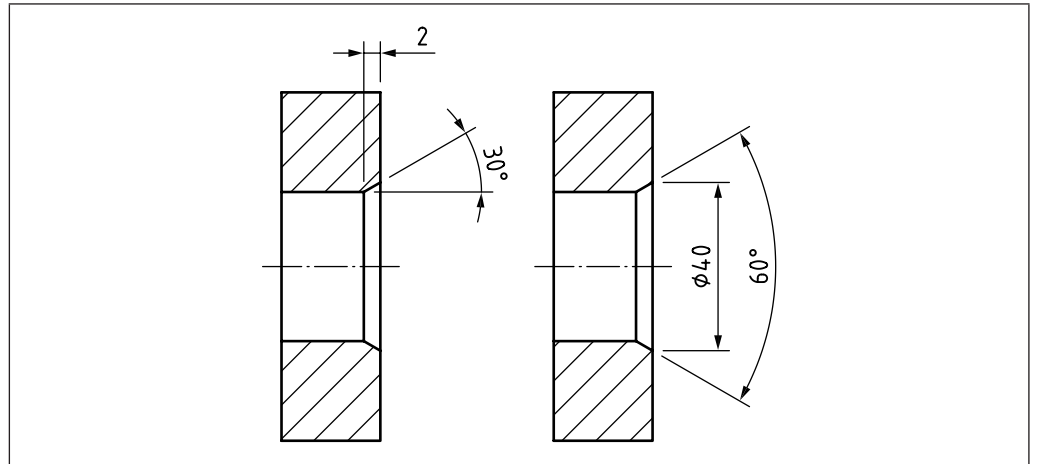




**5.2.10.2 Internal chamfer**

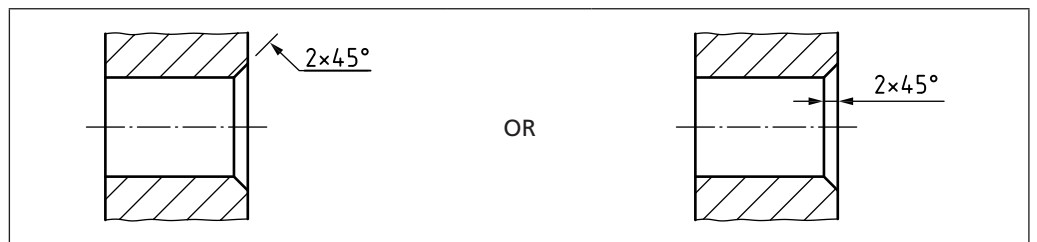
An internal chamfer shall be dimensioned conventionally if the angle of the chamfer is not equal to 45° (see Figure 47).

Figure 47 **Dimension of internal chamfer not equal to 45°**



If the chamfer angle is 45° the indication can be simplified (see Figure 48).

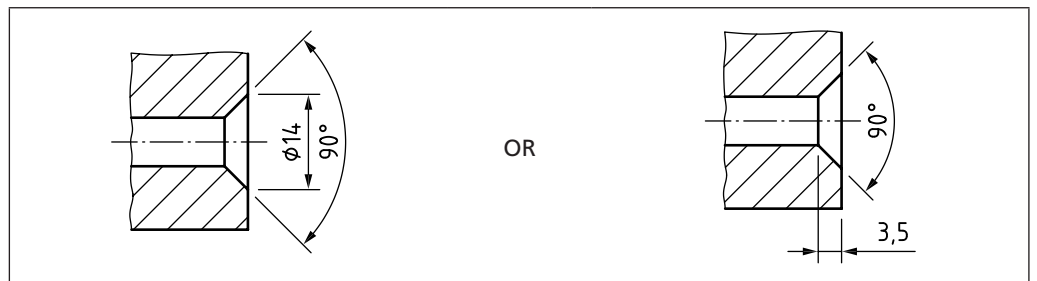
Figure 48 **Dimension of internal chamfer equal to 45°**



**5.2.11 Countersink**

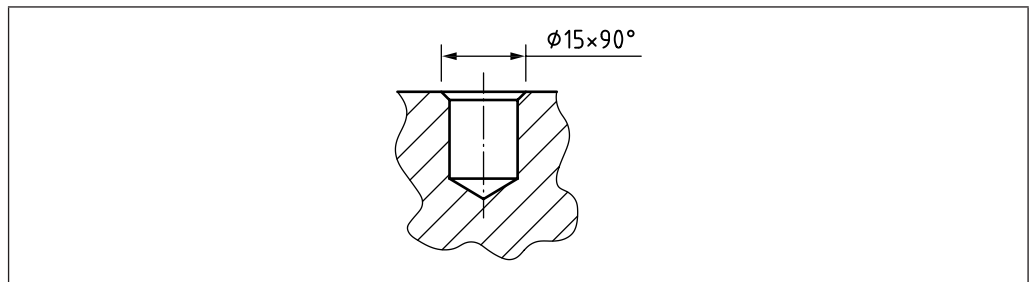
A countersink shall be dimensioned by showing either the required diametrical dimension at the surface and the included angle, or the depth and the included angle (see Figure 49).

Figure 49 **Dimension of countersink**



If the included angle is 90°, the indication can be simplified in accordance with BS ISO 15786 (see Figure 50).

Figure 50 Dimension of countersink: simplification



### 5.2.12 Symmetrical parts

The dimensions of symmetrical arranged features shall be indicated once only (see Figure 51 to Figure 53). The dimension shall indicate the total number of features which occur in the part.

Usually, the line of symmetry of features shall not be dimensioned (see Figure 51 to Figure 53).

In the case of half or quarter representations, and if also required in the case of full representations, a symmetry symbol (see BS ISO 128-30) shall be indicated at both ends of the line of symmetry (see Figure 51 to Figure 53).

In the case of half or quarter representations, the dimension lines that need to cross the line of symmetry shall extend past the axis of symmetry; the second termination shall then be omitted (see Figure 51 to Figure 53).

Figure 51 Symmetrical parts

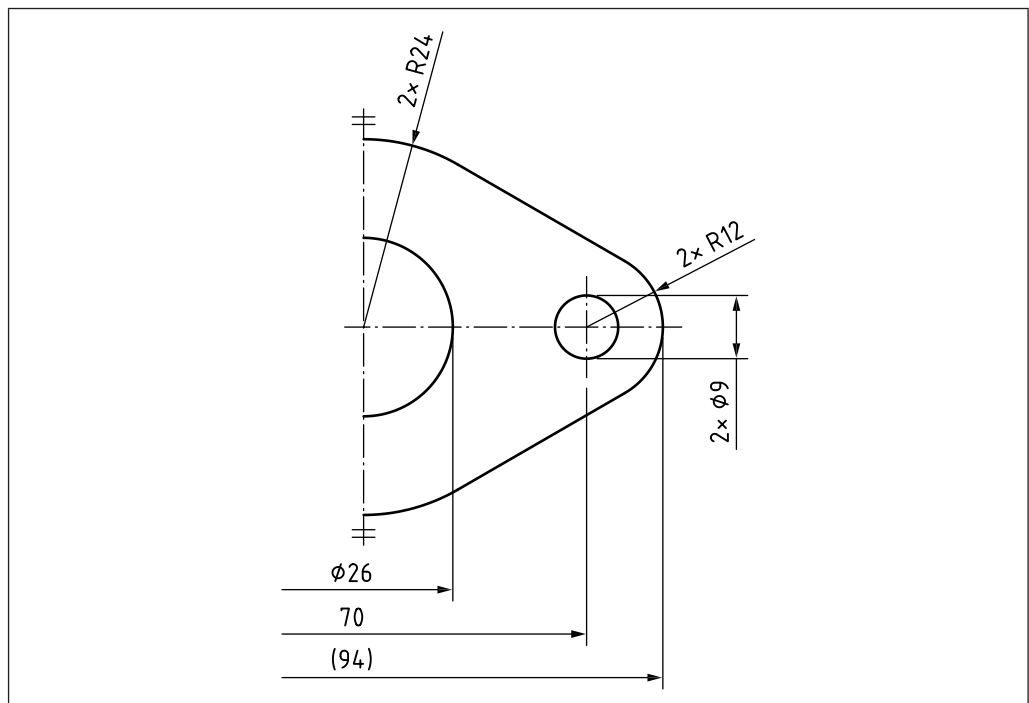


Figure 52 Symmetrical parts

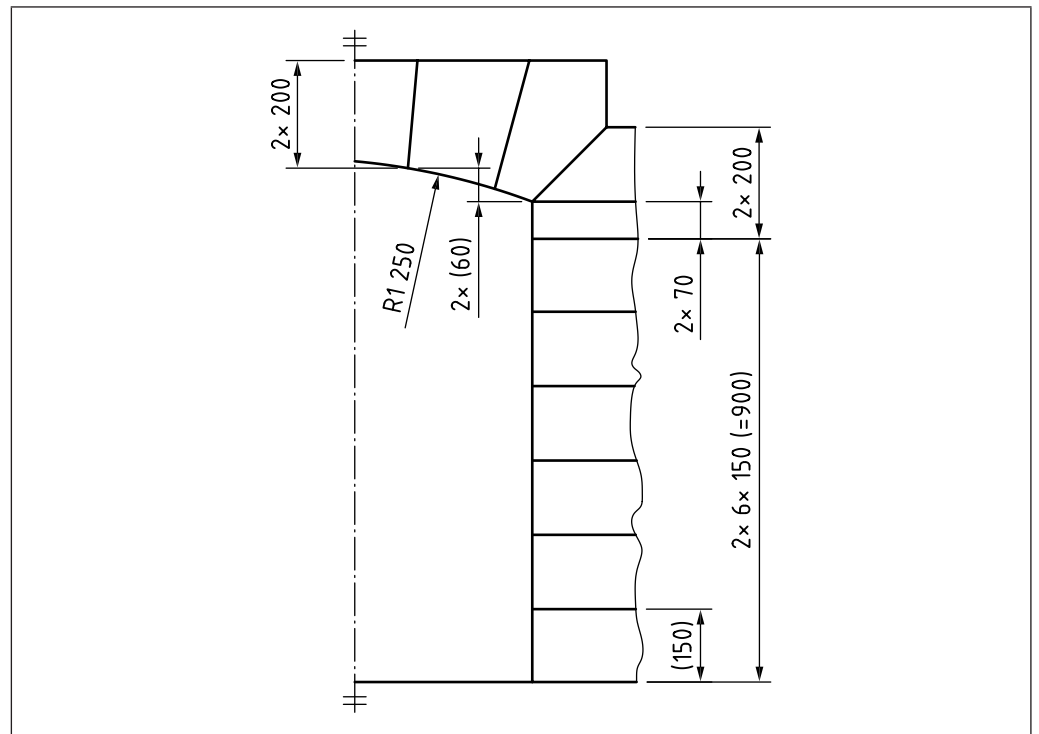
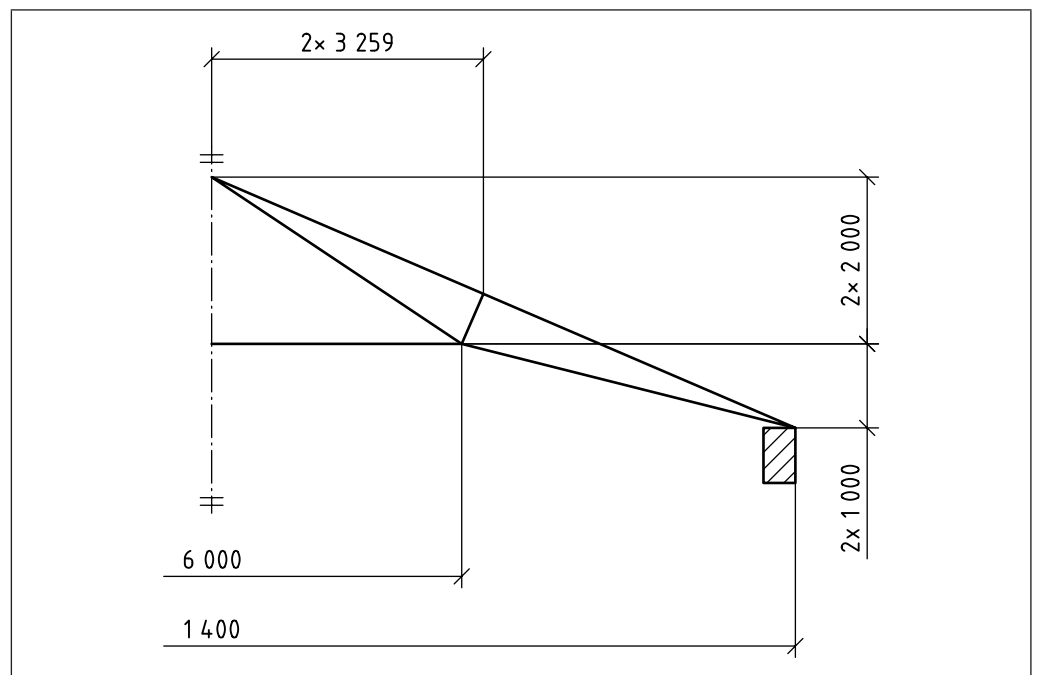


Figure 53 Symmetrical parts



**5.2.13 Indication of levels**

Levels on vertical views, sections and cuts shall be indicated by an open 90° arrowhead connected with a vertical line and horizontal line above which the numerical value of level is placed (see Figure 54).

Levels for specified points on horizontal (planes) views and sections shall be indicated by a numerical value of the level placed above a line connected to the point indicated by "X" (see Figure 55).

Figure 54 Indication of level on vertical view

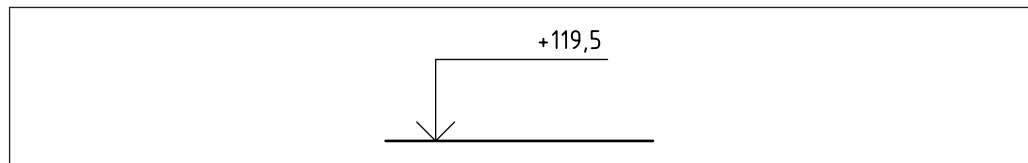
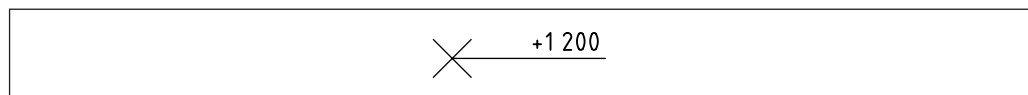


Figure 55 Indication of level on horizontal view or section



## 5.2.14 Dimensioning of curved features

### 5.2.14.1 Curved feature defined by radii

Where appropriate, a curved feature shall be defined by radii, as shown in Figure 56 and Figure 57.

Figure 56 Example of curved feature defined by radii

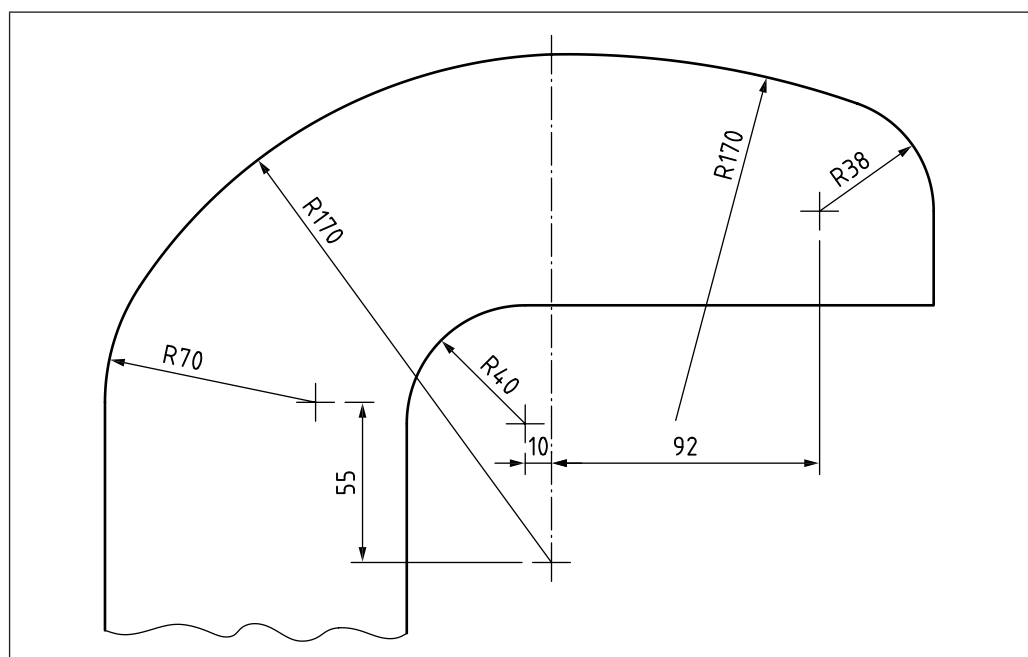
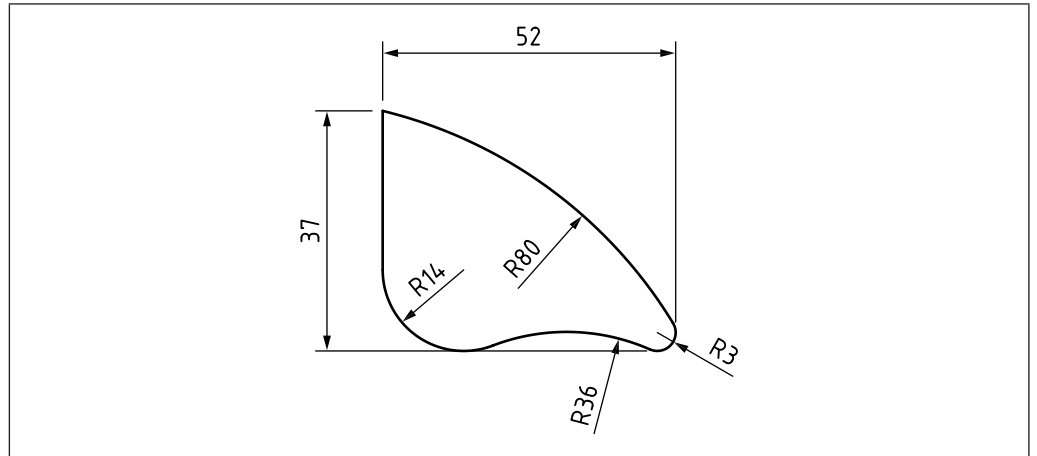


Figure 57 Example of curved feature defined by radii



5.2.14.2 Curved feature defined by coordinate dimensions

Dimensioning of curved features using linear or polar coordinates shall be indicated by dimensions to points on the profile (see Figure 58 and Figure 59).

Figure 58 Curved feature defined by coordinate dimensions

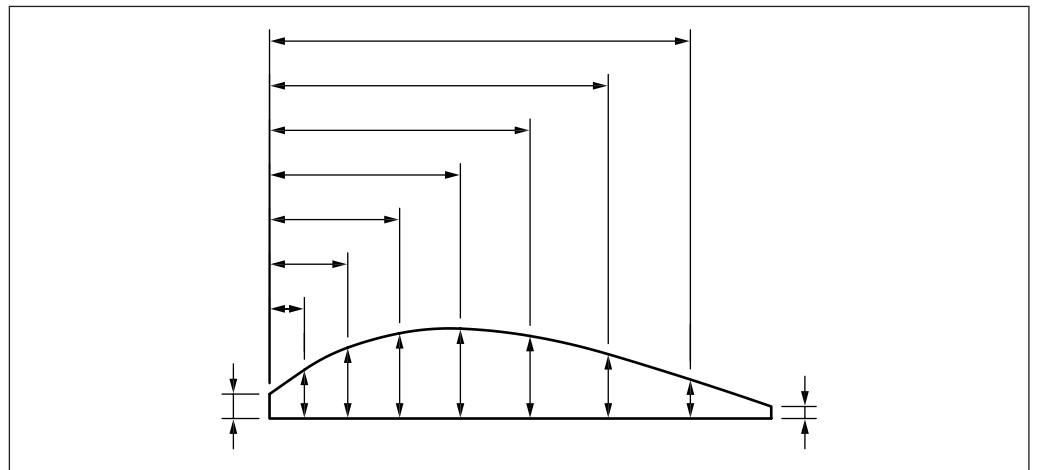
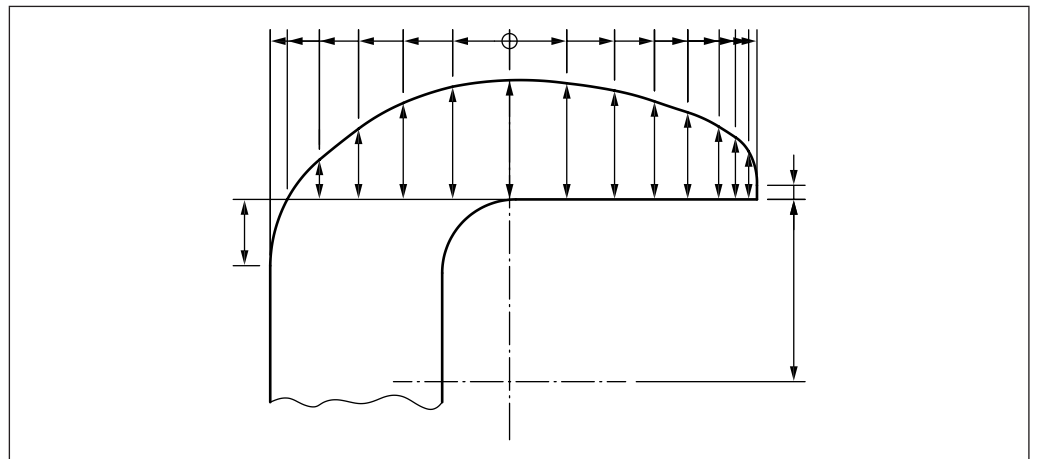


Figure 59 Curved features defined by coordinate dimensions



## 5.2.15 Arrangements of dimensions

### 5.2.15.1 General

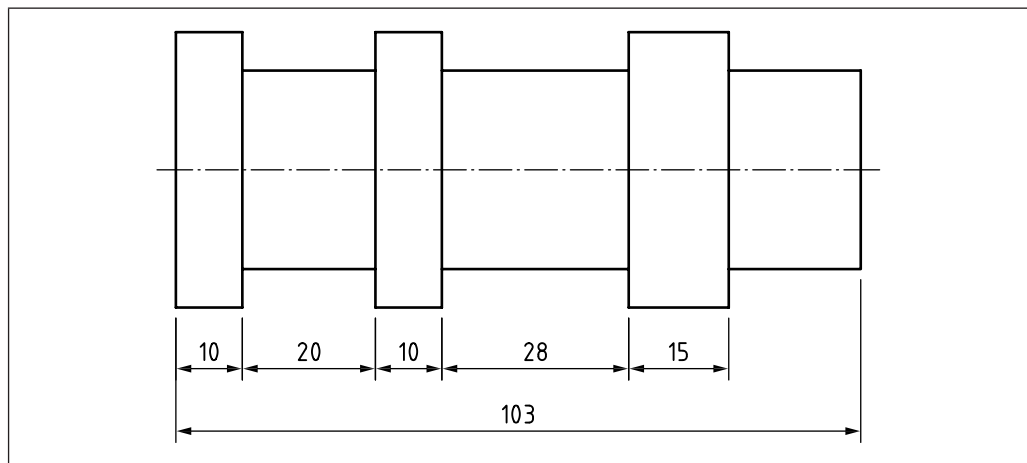
Dimensional values indicated in decimal notation shall use a comma as the decimal marker.

### 5.2.15.2 Chain dimensioning

Using chain dimensioning, chains of single dimensions shall be arranged in a row (see Figure 60).

Chains of single dimensions shall be used only where the possible accumulation of tolerances does not impinge on the functional requirements of the workpiece.

Figure 60 Example of chain dimensioning



### 5.2.15.3 Parallel dimensioning

The dimension lines shall be drawn parallel in one, two or three orthogonal directions, or concentrically (see Figure 61 and Figure 62).

Figure 61 Example of parallel dimensioning

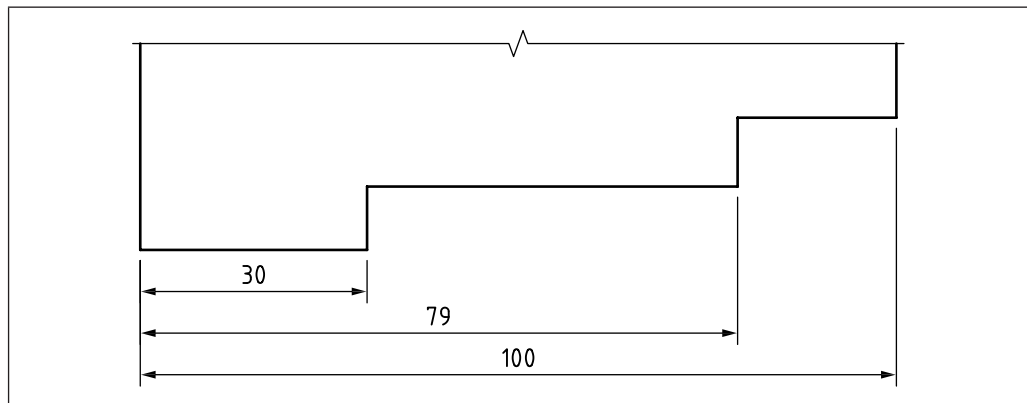
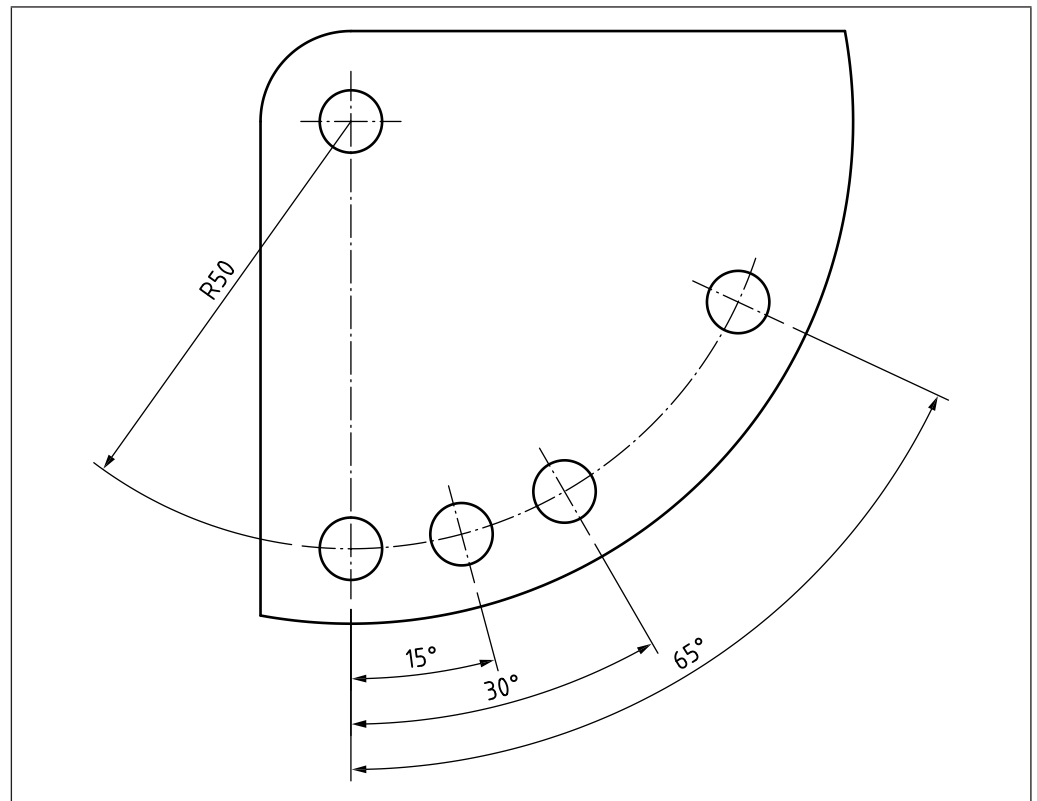


Figure 62 Example of parallel dimensioning



#### 5.2.15.4 Running dimensioning

##### 5.2.15.4.1 General

Running dimensioning is simplified parallel dimensioning. The origin(s) of the dimension line(s) shall be indicated in accordance with 5.2.5 (see Figure 21).

Dimensional values shall be placed near the terminator, remote from the origin, and can be either:

- in line with the corresponding extension line (see Figure 63); or
- above and clear of the dimension line (see Figure 64).

*NOTE* An alternate representation of running dimensions can be used where:

- the origin of the dimension(s) is shown in an appropriate location to indicate where the dimensions are measured from;
- the dimension values are shown on abbreviated dimension lines, where only one arrow is used, directed to the feature to which the dimension value applies (see Figure 63).

##### 5.2.15.4.2 Running dimensioning in two directions

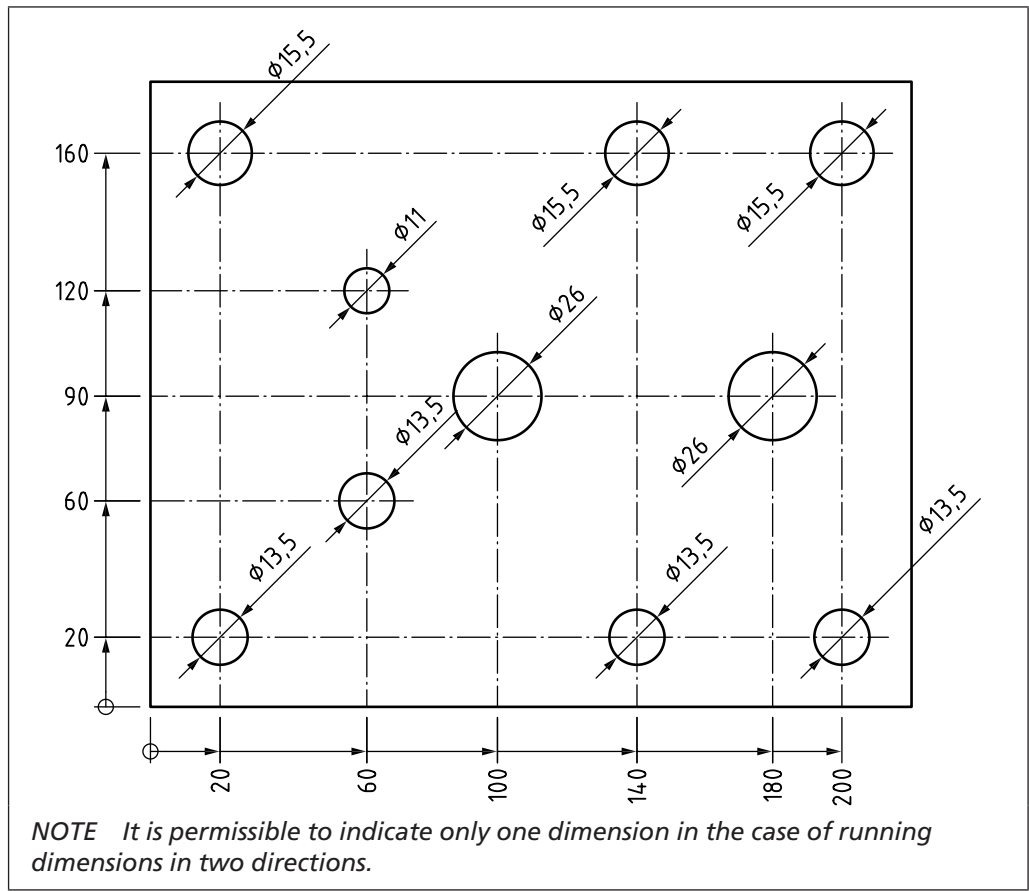
Running dimensioning in two directions shall utilize either:

- one continuous dimension line and one origin; or
- two dimension lines, inclined to each other, and two origins (see Figure 63).

In the case of two directions that are rectangular to each other, the running dimension shall be indicated by two origin symbols.

*NOTE* Figure 63 shows the running dimension values on the same line as the corresponding origin symbol.

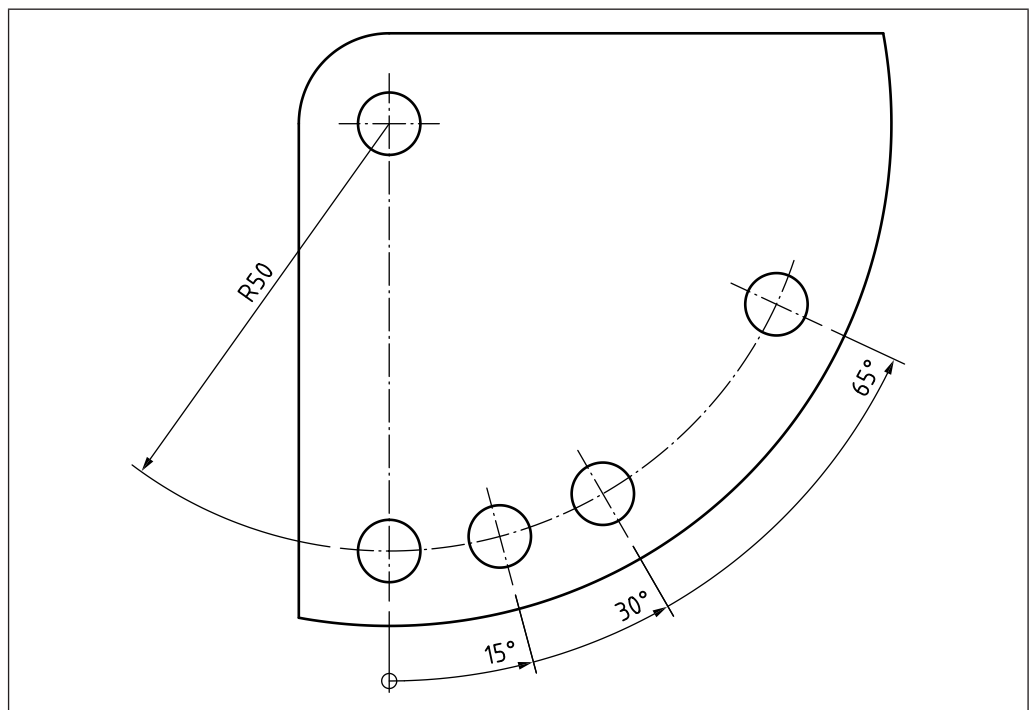
Figure 63 Two dimension lines, inclined to each other, and two origins



5.2.15.4.3 Running dimensioning of angles

Running dimensioning of angles shall be indicated by one origin symbol and arrowheads to the extension lines of the feature (see Figure 64).

Figure 64 Running dimensioning of angles





5.2.16 Cartesian coordinate dimensioning

COMMENTARY ON 5.2.16

Cartesian coordinates are defined starting from the origin by linear dimensions in orthogonal directions (see Figure 65 and Figure 66). Neither dimension lines nor extension lines are drawn.

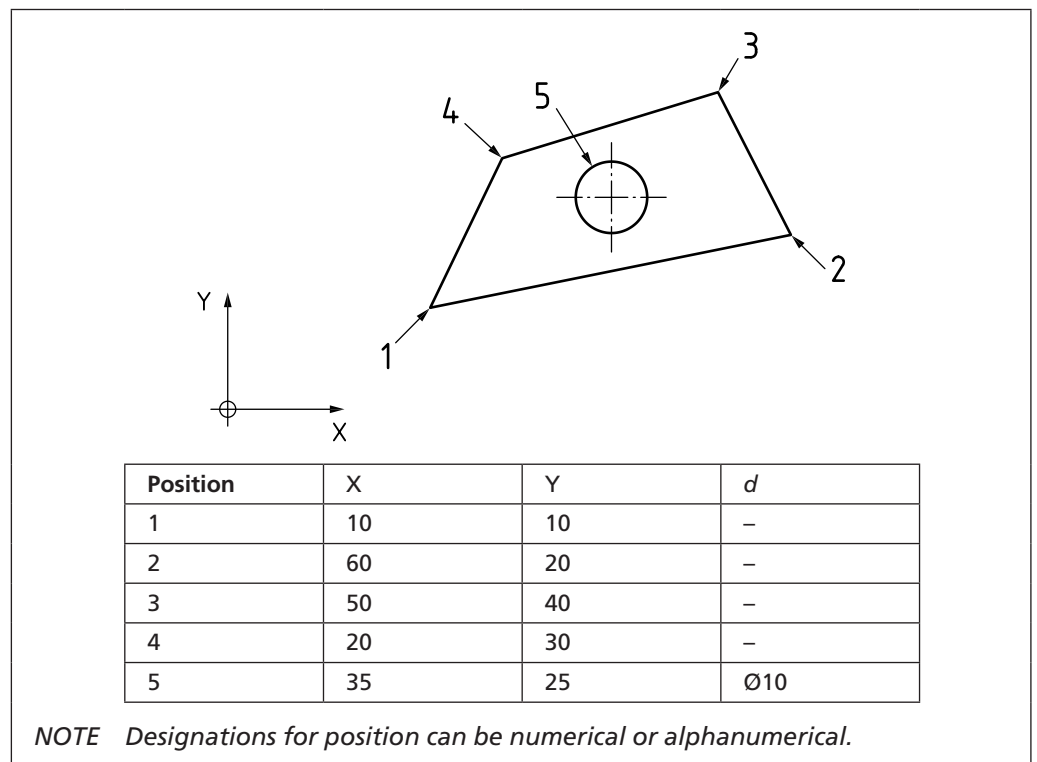
The dimensional values indicated in the negative directions shall have negative signs.

The origin used for coordinate dimensioning shall be indicated (see Figure 65).

The coordinates can be indicated by a reference letter(s) or number which appears in a table together with the value of the coordinate, or by the direct indication of the coordinates.

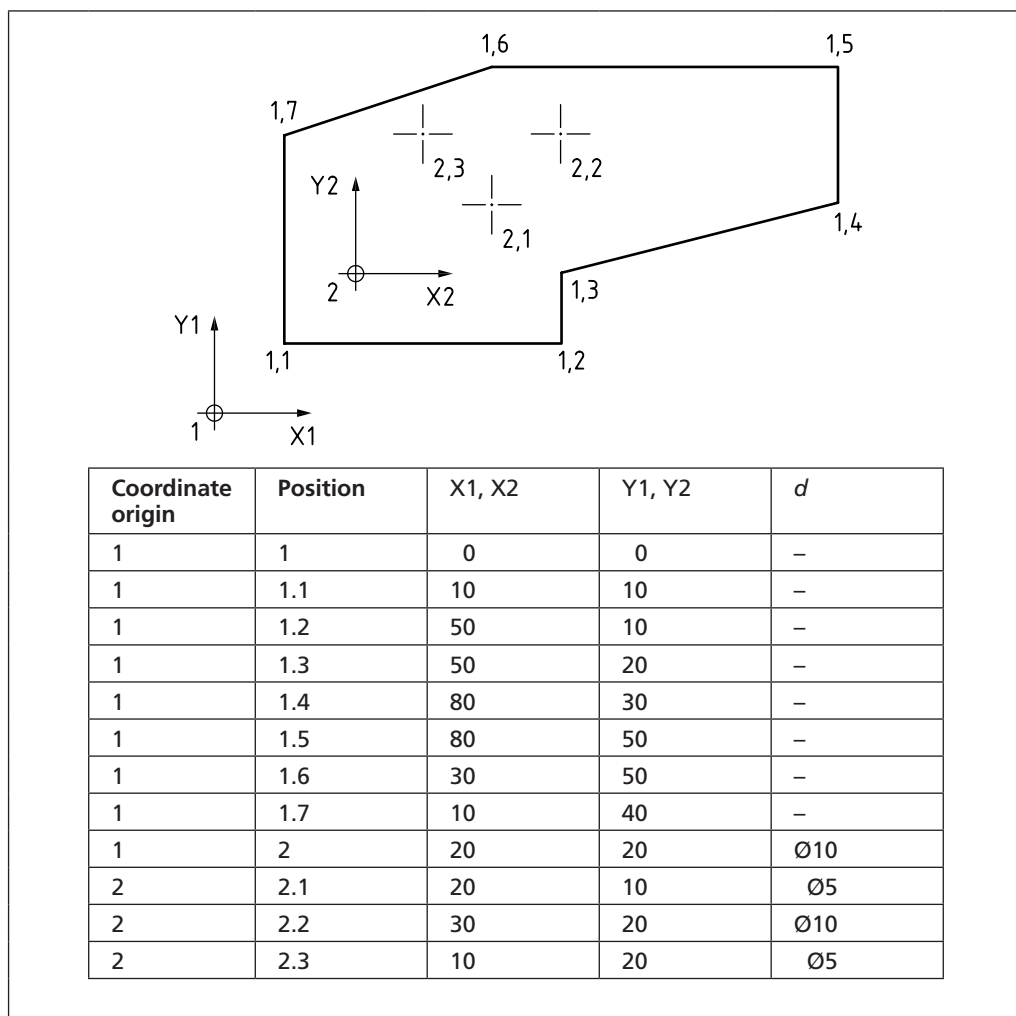
NOTE The reference letter(s) or number or the coordinate value can be placed adjacent to the coordinate location or indicated using a leader line.

Figure 65 Cartesian coordinate dimensioning



Where the main coordinate system has subsystems, the origin of the coordinate systems and the specific positions within the coordinate systems shall be numbered continuously by Arabic numerals. A point shall be used as a separation symbol (see Figure 66).

Figure 66 Cartesian coordinate dimensioning



## 5.3 Dimensioning common features

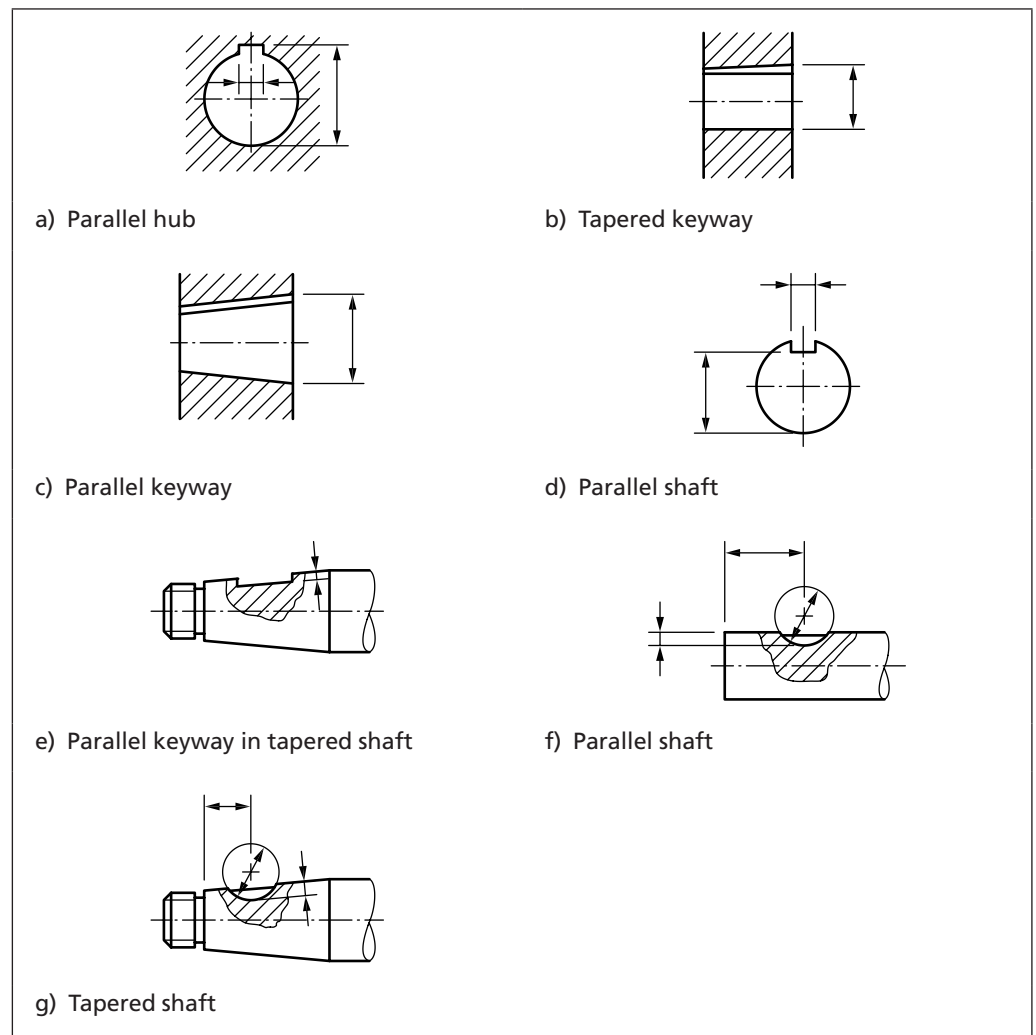
### 5.3.1 Keyways

Keyways in hubs or shafts shall be dimensioned by one of the methods shown in Figure 67.

*NOTE 1 Limit tolerances and/or geometrical tolerances are also required.*

*NOTE 2 Further information on keys and keyways is given in BS 4235-1 and BS 4235-2.*

Figure 67 Dimensioning of keyways



### 5.3.2 Screw threads

The following standards provide the definition for metric ISO screw threads.

BS 3643-1 *ISO metric screw threads – Part 1: Principles and basic data*

BS 3643-2 *ISO metric screw threads – Part 2: Specification for selected limits of size*

BS 4827 *Specification for ISO miniature screw threads – Metric series*

BS ISO 261 *ISO general purpose metric screw threads – General plan*

BS ISO 262 *ISO general purpose metric screw threads – Selected sizes for screws, bolts and nuts*

BS ISO 965-1 *ISO general purpose metric screw threads – Tolerances – Part 1: Principles and basic data*

Screw threads shall be specified according to functional requirement.

### 5.3.3 Edges specification

Edges shall be specified in accordance with BS ISO 13715.

*NOTE* Examples of how edges can be specified are given in Table 9. For full details, though, see BS ISO 13715.

Table 9 Examples of indication of edges

Indication	Meaning	Explanation
		External edge with burr permitted up to 0,1 mm; burr direction undefined.
		External edge with permitted burr; size and direction of burr undefined.
		External edge with burr acceptable up to 0,3 mm; burr direction defined.
		External edge with burr acceptable up to 0,3 mm; burr direction defined.
		External edge without burr; undercut permitted, size undefined.
		External edge without burr; undercut up to 0,3 mm.
		External edge without burr; undercut in the zone from 0,1 mm to 0,5 mm.
		External edge with burr permitted up to 0,05 mm or undercut down to 0,05 mm (sharp edge); burr direction undefined.

Abbreviations: LMC = least material condition; MMC = maximum material condition.

## 5.4 Dimensional tolerancing

### 5.4.1 General

#### COMMENTARY ON 5.4.1

*All features on component parts always have a size and a geometrical shape. For the deviation of size and for the deviations of the geometrical characteristics (form, orientation and location) the function of the part requires limitations which, when exceeded, impair this function.*

The tolerancing on the drawing shall be complete to ensure that the elements of size and geometry of all features are controlled, i.e. nothing shall be implied or left to judgement in the workshop or in the inspection department.

*NOTE 1 The use of general tolerances for size and geometry simplifies the task of ensuring that the prerequisites are met.*

*NOTE 2 See BS EN 22768-1 for more information on general tolerances.*

### 5.4.2 Methods of specifying tolerances

The necessary tolerances shall be specified in one or more of the following ways:

- a) separate indication on the drawing;
- b) reference to general tolerances noted on the drawing;
- c) reference to a standard containing general tolerances;
- d) reference to other documents.

### 5.4.3 Indication of tolerances

#### 5.4.3.1 General

Dimensional tolerancing for mechanical engineering shall be in accordance with BS EN ISO 14405.

*NOTE 1 BS EN ISO 14405 can also be applied to fields other than mechanical engineering. Some of these rules are summarized here for information.*

*NOTE 2 Depending on the field of application, the tolerances of dimensions can be indicated by:*

- *limit deviations;*
- *limits of dimension;*
- *general tolerances.*

All tolerances shall apply to the represented state of the feature in the technical drawing.

When tolerance limits are indicated in a vertical orientation (e.g. limit deviations, dimension limit values) the decimal marker of the upper and lower shall be aligned. When a tolerance limit is not shown with a decimal marker, the remaining digits shall be aligned as if the decimal marker had been displayed, e.g.:

$$2 \times 55_{-0,15}^{+0,20}$$

$$2 \times 55_{-0,15}^0$$

If two deviations relating to the same dimension have to be shown, both shall be expressed to the same number of decimal places (see Figure 68), except if one of the deviations is zero. This shall also be applied if the limits of size are indicated (see Figure 69).

Figure 68 **Example: expression of two deviations to the same number of decimal places**

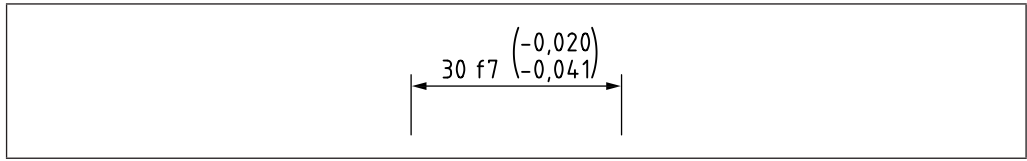
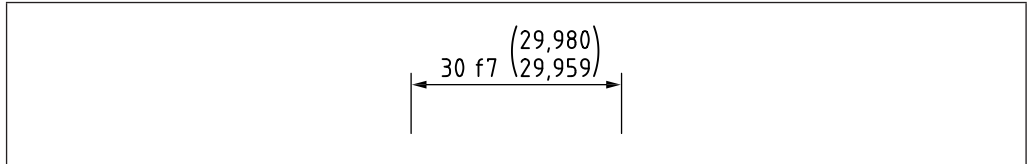
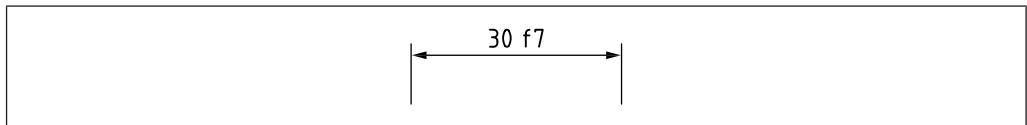


Figure 69 **Example: expression of two limits of size to the same number of decimal places**



*NOTE 3 For dimensions displayed in accordance with BS EN ISO 286-1, it is not necessary to express the values of the deviations unless they are needed (see Figure 70).*

Figure 70 **Example: expression of deviations from dimensions displayed in accordance with BS EN ISO 286-1**



**5.4.3.2 Limit deviations**

The components of a toleranced dimension shall be indicated in the following order (see Figure 71 to Figure 75):

- a) the dimensional value;
- b) the limit deviations.

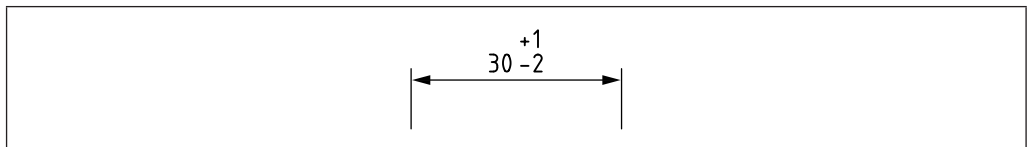
A space shall separate the dimensional values and the tolerance indication, e.g.:

- 55 ±0,2;
- 30 min;
- ø10 h7.

Limit deviations shall be expressed in the same unit as the dimensional value.

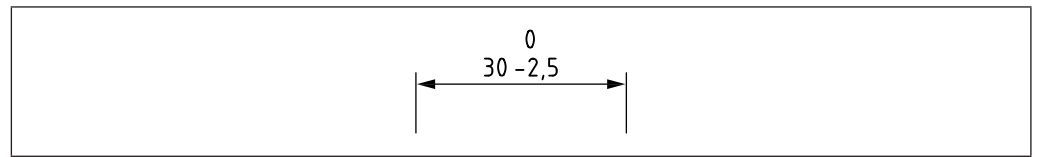
Limit deviations shall be indicated by indicating the upper deviation above the lower deviation (see Figure 71 and Figure 73).

Figure 71 **Components of a toleranced dimension**



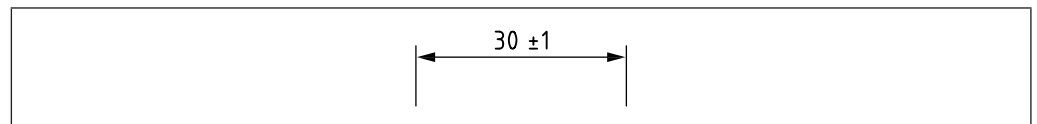
If one of the two limit deviations is zero, this shall be expressed explicitly by the digit zero shown without sign (see Figure 72).

Figure 72 Components of a tolerated dimension



If the tolerance is symmetrical in relation to the dimensional value, the limit deviation shall be indicated only once, preceded by the plus-minus sign ( $\pm$ ) (see Figure 73).

Figure 73 Components of a tolerated dimension

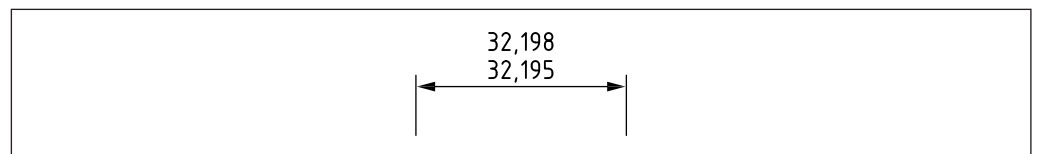


### 5.4.3.3 Limits of dimension

#### 5.4.3.3.1 Maximum and minimum limit dimensions

The limits of dimensions shall be indicated by a maximum and a minimum dimension (see Figure 74). The larger dimension shall be placed above the smaller dimension.

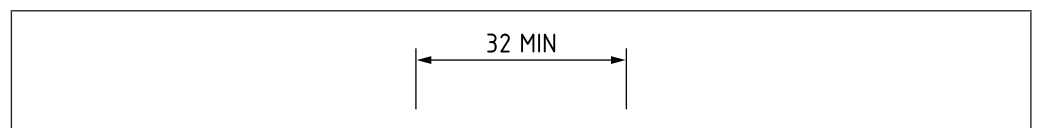
Figure 74 Limits of dimensions



#### 5.4.3.3.2 Single limit dimensions

To limit the dimension in one direction only, the word "MIN" or "MAX" shall be added after the dimensional value (see Figure 75).

Figure 75 Single limit dimension



### 5.4.3.4 General tolerances

#### 5.4.3.4.1 General tolerance notes

Where general tolerances are used these shall be noted on the drawing (see Figure 76).

Figure 76 Use of general tolerance notes

TOLERANCE EXCEPT WHERE OTHERWISE STATED $\pm X$	TOLERANCES EXCEPT WHERE OTHERWISE STATED  <table style="width: 100%; border-collapse: collapse;"> <thead> <tr> <th style="text-align: left;">SIZE</th> <th style="text-align: left;">TOLERANCE</th> </tr> </thead> <tbody> <tr> <td>- UP TO X</td> <td><math>\pm A</math></td> </tr> <tr> <td>OVER X UP TO XX</td> <td><math>\pm B</math></td> </tr> <tr> <td>OVER XX UP TO XXX</td> <td><math>\pm C</math></td> </tr> <tr> <td>OVER XXX -</td> <td><math>\pm D</math></td> </tr> <tr> <td>ON ANGLES</td> <td><math>\pm E</math></td> </tr> </tbody> </table>	SIZE	TOLERANCE	- UP TO X	$\pm A$	OVER X UP TO XX	$\pm B$	OVER XX UP TO XXX	$\pm C$	OVER XXX -	$\pm D$	ON ANGLES	$\pm E$
SIZE		TOLERANCE											
- UP TO X	$\pm A$												
OVER X UP TO XX	$\pm B$												
OVER XX UP TO XXX	$\pm C$												
OVER XXX -	$\pm D$												
ON ANGLES	$\pm E$												
TOLERANCE ON CAST THICKNESS $\pm X\%$													
FOR TOLERANCE ON FORGING DIMENSIONS SEE BS EN 10243-1													

#### 5.4.3.4.2 General tolerance standards

When use is made of BS EN 22768-1 for general tolerances, tolerances for dimensions shall be as given in Table 10, Table 11 and Table 12.

Table 10 Permissible deviations for linear dimensions except for broken edges

Tolerance class		Permissible deviations for basic size range							
Designation	Description	0,5 <sup>A)</sup> up to 3	over 3 up to 6	over 6 up to 30	over 30 up to 120	over 120 up to 400	over 400 up to 1 000	over 1 000 up to 2 000	over 2 000 up to 4 000
f	fine	$\pm 0,05$	$\pm 0,05$	$\pm 0,1$	$\pm 0,15$	$\pm 0,2$	$\pm 0,3$	$\pm 0,5$	-
m	medium	$\pm 0,1$	$\pm 0,1$	$\pm 0,2$	$\pm 0,3$	$\pm 0,5$	$\pm 0,8$	$\pm 1,2$	$\pm 2$
c	coarse	$\pm 0,2$	$\pm 0,3$	$\pm 0,5$	$\pm 0,8$	$\pm 1,2$	$\pm 2$	$\pm 3$	$\pm 4$
v	very coarse	-	$\pm 0,5$	$\pm 1$	$\pm 1,5$	$\pm 2,5$	$\pm 4$	$\pm 6$	$\pm 8$

<sup>A)</sup> For nominal sizes below 0,5 mm, the deviations shall be indicated adjacent to the relevant nominal size(s).

**NOTE** Values in millimetres.

Table 11 Permissible deviations for broken edges (external radii and chamfer heights)

Tolerance class		Permissible deviations for basic size range		
Designation	Description	0,5 <sup>A)</sup> up to 3	over 3 up to 6	over 6
f	fine	$\pm 0,2$	$\pm 0,5$	$\pm 1$
m	medium			
c	coarse	$\pm 0,4$	$\pm 1$	$\pm 2$
v	very coarse			

<sup>A)</sup> For nominal sizes below 0,5 mm, the deviations shall be indicated adjacent to the relevant nominal size(s).

**NOTE** Values in millimetres.



Table 12 Permissible deviations of angular dimensions

Tolerance class		Permissible deviations for ranges of lengths, in millimetres, of the shorter side of the angle concerned				
Designation	Description	up to 10	over 10 up to 50	over 50 up to 120	over 120 up to 400	over 400
f	fine	±1°	±0°30'	±0°20'	±0°10'	±0°5'
m	medium					
c	coarse	±1°30'	±1°	±0°30'	±0°15'	±0°10'
v	very coarse	±3°	±2°	±1°	±0°30'	±0°20'

*NOTE* Due to the inherent risk of unintentionally over-specifying form and orientation controls that can result from the use of general geometrical tolerances, reference to BS EN 22768-2 is inadvisable. BS EN 22768-2 is in the process of being withdrawn. In such cases, general tolerance notes could be used to apply a common tolerance to many of the features on a drawing. The example shown in Figure 76 illustrates the wide field of application of this system.

5.4.3.5 Tolerances in other documents

When tolerances are controlled by another document or method, the document reference shall be indicated on the drawing.

5.4.4 Functional dimensions

Functional dimensions shall be expressed directly (see Figure 77).

*NOTE* The application of this principle results in the selection of origin or datum features on the basis of the function of the product and the method of locating it in any assembly of which it could be a part.

If any datum feature other than one based on the function of the product is used, finer tolerances might be necessary and products which would satisfy functional requirements can be rejected because they exceed these finer tolerances (Figure 78).

Expressing functional dimensions does not preclude the use of any dimensioning arrangement (see 5.2.16) providing functional requirements are satisfied.

Figure 77 Application of dimensions to suite functional requirements

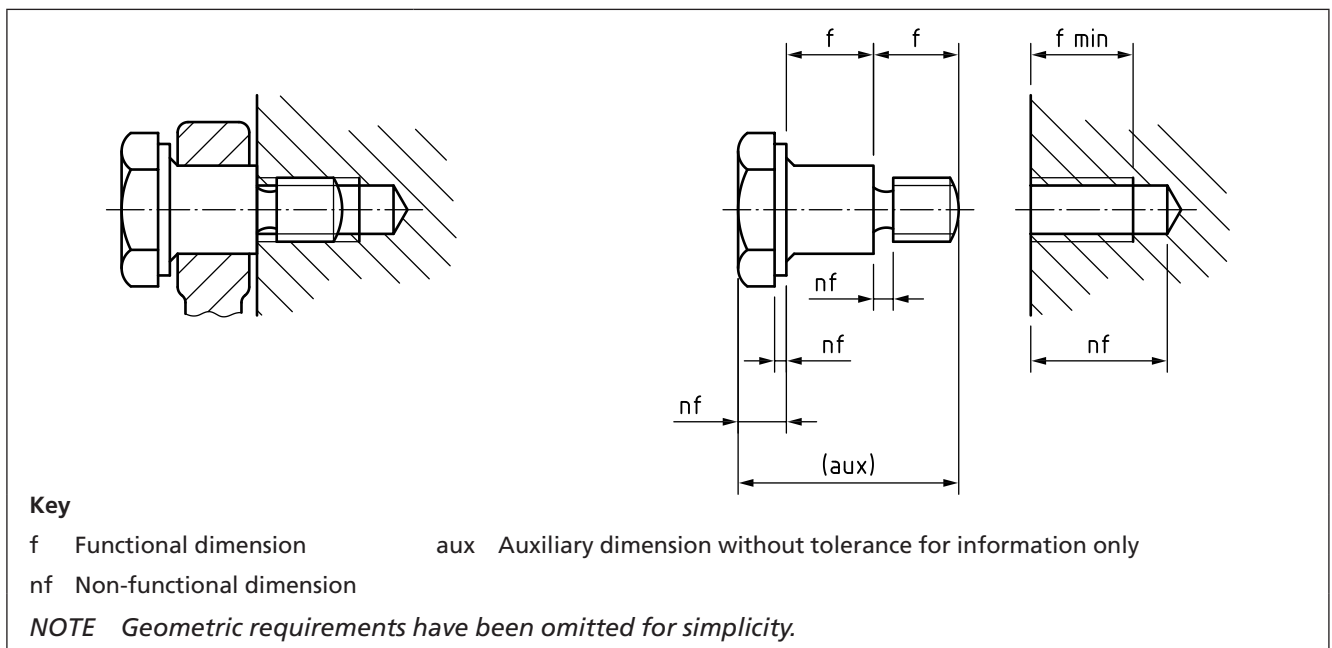
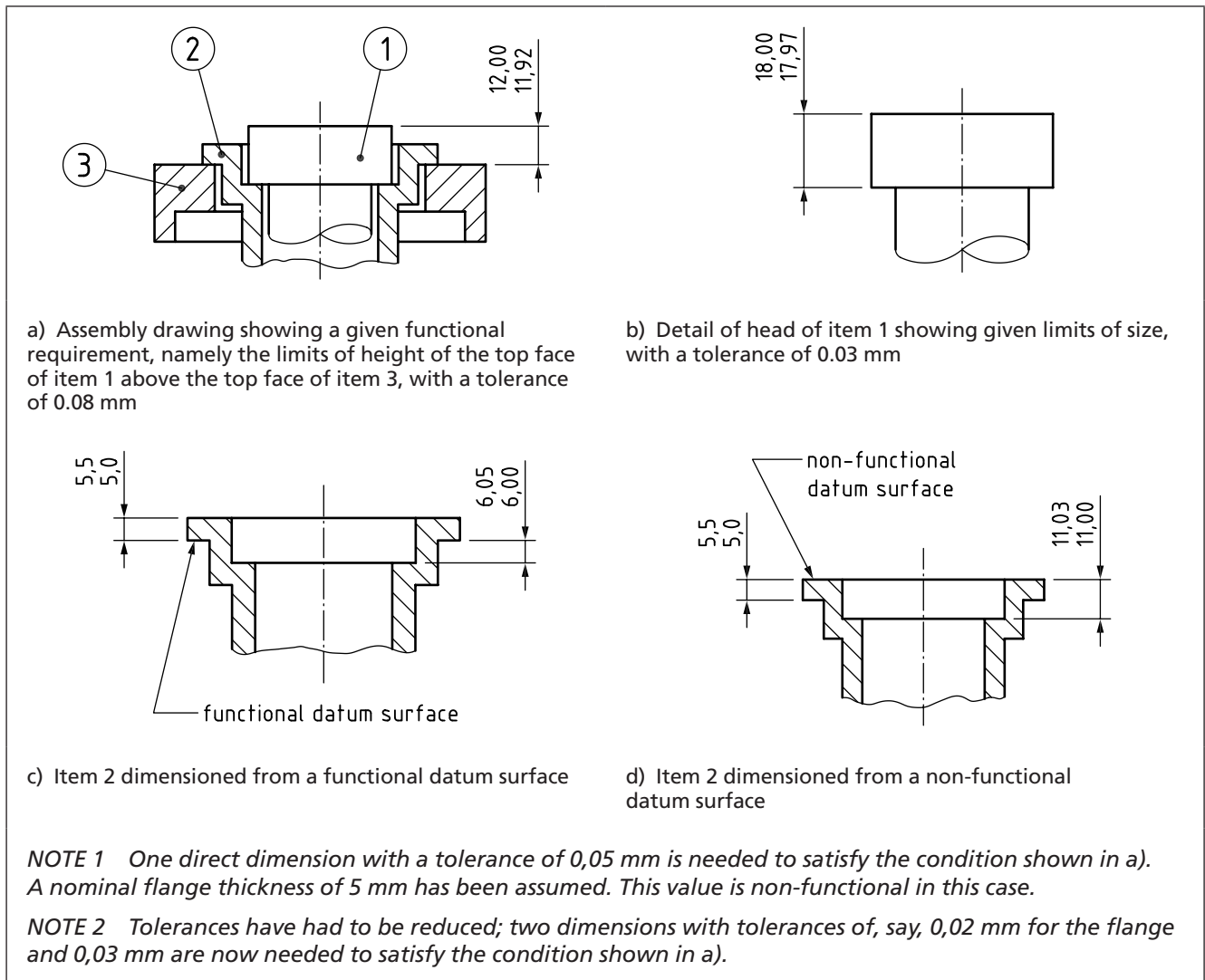


Figure 78 Effect of changing datum surfaces from those determined by functional



## Section 6: Geometrical product specification – Datums and datum systems

### COMMENTARY ON CLAUSE 6

*This section describes some of the main definitions, principles and rules of working with datums and datum features. A more extensive description of datums and datum systems is given in in BS EN ISO 5459. This section is not intended to replace BS EN ISO 5459; it is only intended to make some of the key content more accessible.*

*Some additional options for working with datums are also described here which are not yet published in ISO standards (e.g. the use of non-default association methods). As some of these options are already in use in industry, they are included in this standard with the caveat that whenever they are used, a clear explanation also appears in the specification, and the additional caveat that, when these options do become available through published ISO standards, their symbology and format might differ from those described here.*

### 6.1 General

A datum is an ideal (theoretically perfect) geometrical reference, which is used when defining the location or orientation of other features.

A datum is based on a feature which is known as a datum feature.

Two or three datums can be used together to create a frame of reference used for defining the geometry of a workpiece. Two or three datums working together are known as a datum system.

Datums shall be used to avoid or minimize ambiguity in specifications.

### 6.2 Definitions and explanations

#### 6.2.1 Datum

A datum is a geometrically ideal feature which can be used to define the location or orientation of a tolerance zone.

A datum can be:

- a) a point;
- b) a straight line;
- c) a flat plane; or
- d) a combination of a), b) and c).

A datum consists of the situation feature(s) (see definition in 6.2.2) of a datum feature.

The concept of six degrees of freedom (see definition in 6.2.8) is very useful in understanding the way in which datums work.

#### 6.2.2 Datum feature

The datum feature is a real integral feature or part of an integral feature. The datum feature is often a feature on the workpiece itself, but can also be a feature on a tool or fixture to which the workpiece is attached.

When establishing the datums for a workpiece, the datum feature is a manufactured surface on the workpiece or a fixture, and is a non-ideal feature.

#### 6.2.3 Common datum

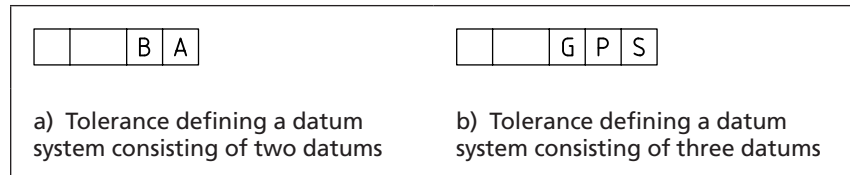
A common datum is a datum based on more than one datum feature.

### 6.2.4 Datum system

A datum system is a set of two or three datums which are used together in a specified order to define a frame of reference for locating or orientating the tolerance zones for other features on a workpiece (see Figure 79). This is achieved by defining the theoretically exact location, or the theoretically exact orientation of the tolerance zone relative to the datum system.

A datum system is defined in a tolerance frame, where two or three datum references are listed, so each geometrical tolerance contains within it the datum system required to fully define or evaluate that requirement. Not all geometrical tolerances require datum systems.

Figure 79 Tolerance defining a datum system



### 6.2.5 Primary datum

The primary datum is the datum listed first in the tolerance frame. This datum is not influenced by constraints from other datums.

### 6.2.6 Secondary datum

The secondary datum is the datum listed second in the tolerance frame. In a datum system, the secondary datum is perfectly oriented or aligned with the primary datum.

### 6.2.7 Tertiary datum

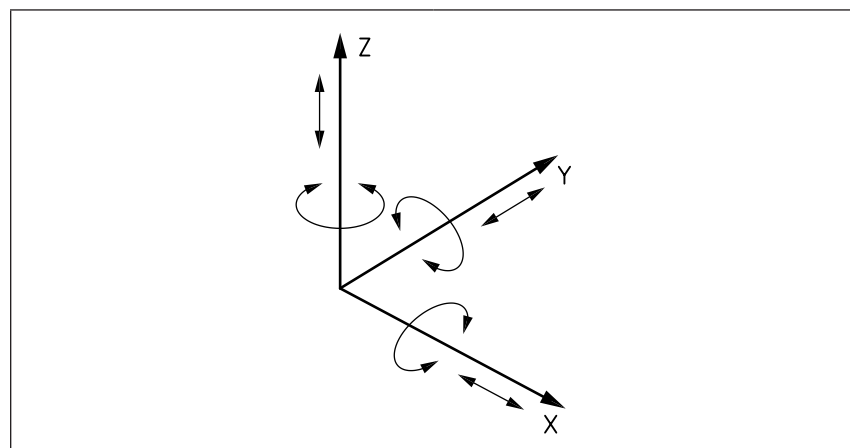
The tertiary datum is the datum listed third in the tolerance frame. In a datum system, the tertiary datum is perfectly oriented or aligned with the primary and secondary datums.

### 6.2.8 Six degrees of freedom

A rigid body is said to have six degrees of freedom (see Figure 80). These can be considered as the freedom to translate, or move, along each of the three axes of a Cartesian coordinate system, and also to rotate around each of these axes. Thus a rigid body has three translational degrees of freedom, and three rotational degrees of freedom.

Some or all of these degrees of freedom can be locked by constraining the rigid body in various ways.

Figure 80 Degrees of freedom



**6.2.9 Situation feature**

A situation feature is one of the ideal geometrical elements used when defining the location or orientation of a surface.

A situation feature can be:

- a) a point;
- b) a straight line; or
- c) a flat plane.

For example, the situation feature for a planar surface is a flat plane, the situation feature for a cylinder is a straight line (the axis of the cylinder), and the situation feature for a sphere is a point (the centre of the sphere).

Locking the location or orientation of a situation feature causes some of the degrees of freedom of the surface to be locked.

Some types of surface have more than one situation feature. A cone has two situation features, a straight line (axis) and a point.

The situation features for any non-ideal, manufactured surface are based on the associated feature (see Table 13). The associated feature is an ideal feature which is fitted to the real feature, or to data extracted from the real feature (see BS EN ISO 17450-1 and BS EN ISO 5459).

**Table 13 Situation features (1 of 2)**



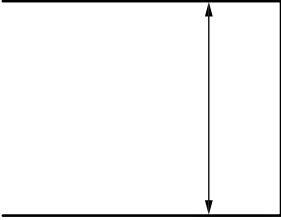
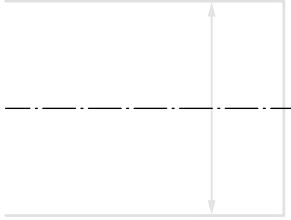
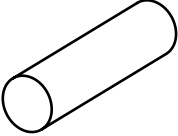
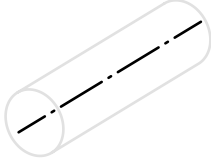
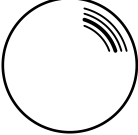

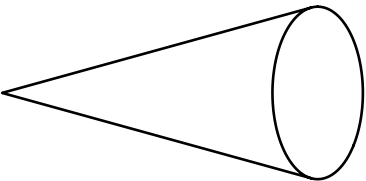
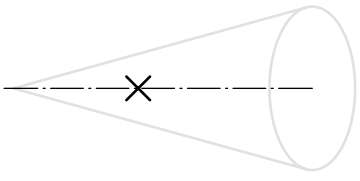
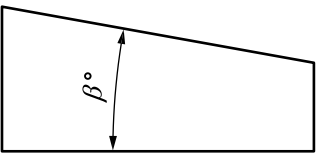
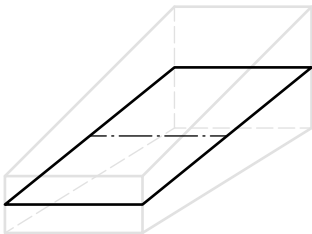

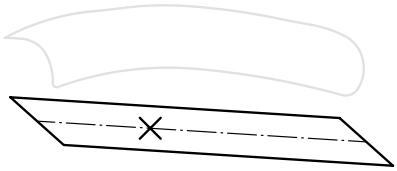
Feature type	Situation feature(s)
Flat plane: 	Flat plane: 
Two parallel opposed planes: 	Flat plane: 
Cylinder: 	Straight line: 
Sphere: 	Point: 

Table 13 Situation features (2 of 2)

Feature type	Situation feature(s)
Cone: 	Straight line point and point: 
Wedge (prismatic): 	Flat plane and straight line: 
Complex: 	Flat plane, straight line and point: 

**6.2.10 Associated feature**

An associated feature is an ideal feature which is established from a non-ideal (real or extracted) feature using an association operation.

The associated features used to establish datums simulate the contact or interface with other components.

*NOTE See Annex C for further information about association.*

**6.3 Deriving datums from datum features**

*COMMENTARY ON 6.3*

The datum, by default<sup>6)</sup>, is based on an ideal feature in contact with the datum feature (non-ideal feature), remaining outside the datum feature such that the deviation of the datum from any point on the datum feature is minimized.

**6.3.1 Datum based on a planar datum feature**

*COMMENTARY ON 6.3.1*

The datum feature consists of a non-ideal plane (see Figure 81).

A primary datum based on the datum feature in Figure 81 shall be a tangent plane, in contact with the surface but outside the material of the datum feature, such that the distance  $d_{max}$  (see Figure 82) is minimized.

A secondary datum based on the datum feature in Figure 81 shall be a tangent plane, in contact with the surface but outside the material of the datum feature, which is perfectly oriented or aligned with the primary datum.

<sup>6)</sup> Other association methods can be specified.

A tertiary datum based on the datum feature in Figure 81 shall be a tangent plane, in contact with the surface but outside the material of the datum feature, which is perfectly oriented or aligned with the primary and secondary datum.

Figure 81 Datum based on a planar datum feature

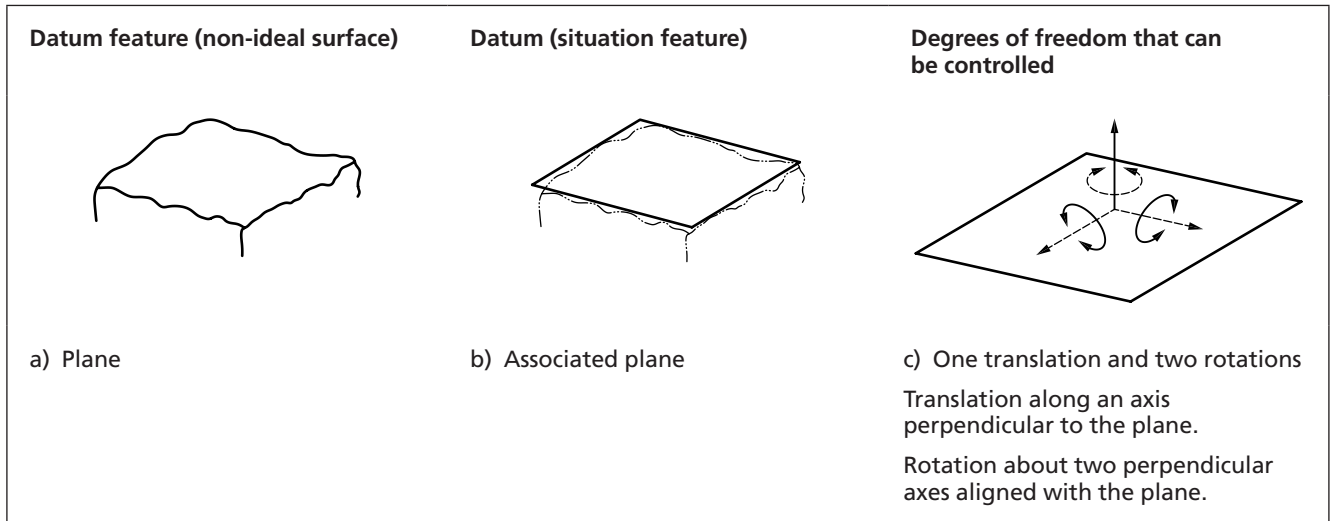
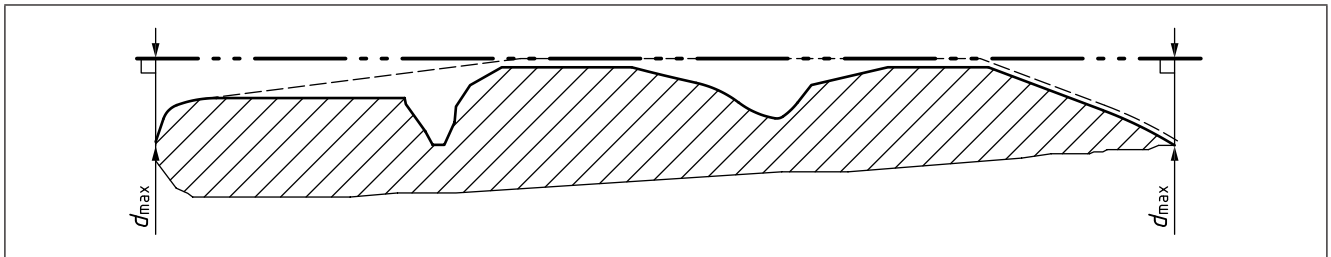


Figure 82 Tangent plane



### 6.3.2 Datum based on two parallel, opposed planes (external)

#### COMMENTARY ON 6.3.2

An external feature consisting of two parallel, opposed planes would be a feature such as a flange.

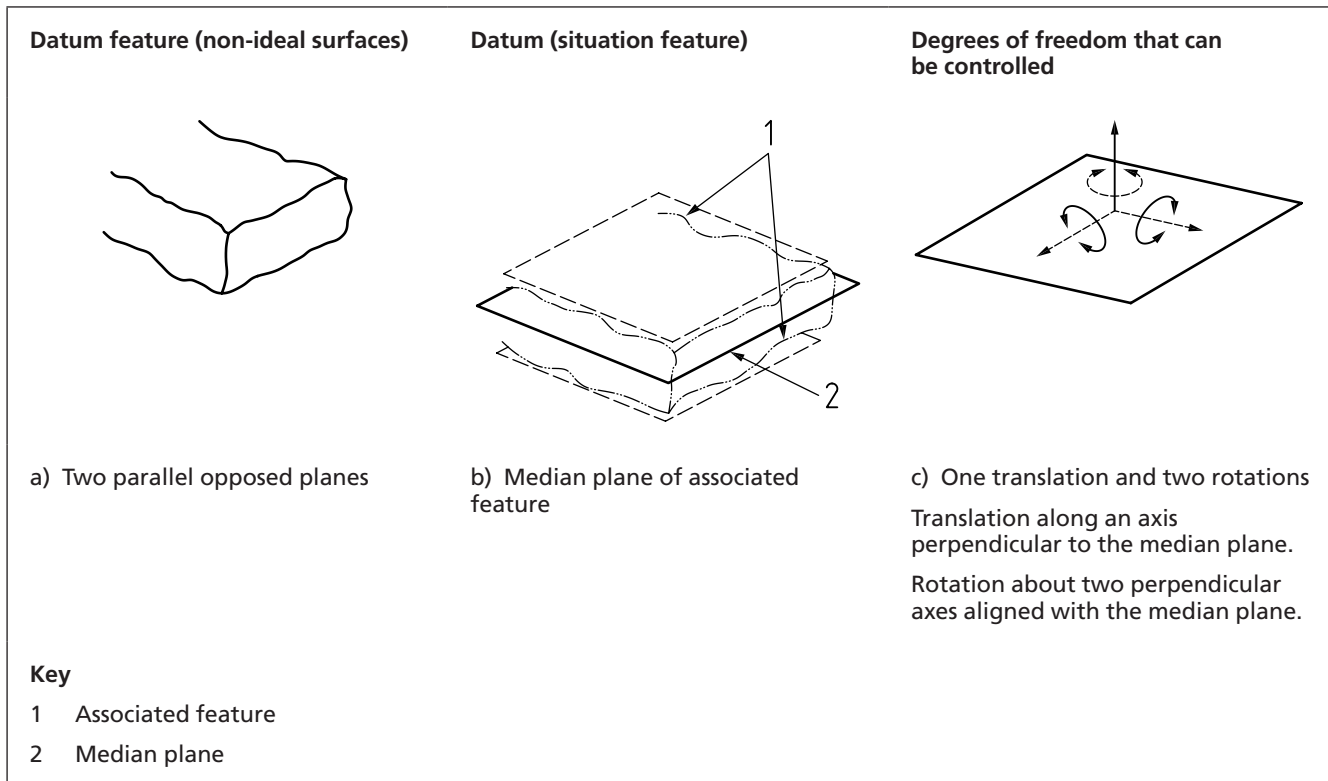
The datum feature consists of two non-ideal planes (see Figure 83).

A primary datum based on the datum feature in Figure 83 shall be a median plane, constructed from two parallel planes, which are in contact with the two surfaces of the datum feature but outside the material of the datum feature, such that their separation is minimized.

A secondary datum based on the datum feature in Figure 83 shall be a median plane, constructed from two parallel planes, which are in contact with the two surfaces of the datum feature but outside the material of the datum feature, such that their separation is minimized while they are perfectly oriented or aligned with the primary datum.

A tertiary datum based on the datum feature in Figure 83 shall be a median plane, constructed from two parallel planes, which are in contact with the two surfaces of the datum feature but outside the material of the datum feature, such that their separation is minimized while they are perfectly oriented or aligned with the primary and secondary datum.

Figure 83 Datum based on two parallel, opposed planes



### 6.3.3 Datum based on two parallel, opposed planes (internal)

**COMMENTARY ON 6.3.3**

*The datum feature consists of two non-ideal planes.*

A primary datum based on the datum feature in Figure 83 shall be a median plane, constructed from two parallel planes, which are in contact with the two surfaces of the datum feature but outside the material of the datum feature, such that their separation is maximized.

A secondary datum based on the datum feature in Figure 83 shall be a median plane, constructed from two parallel planes, which are in contact with the two surfaces of the datum feature but outside the material of the datum feature, such that their separation is maximized while they are perfectly oriented or aligned with the primary datum.

A tertiary datum based on the datum feature in Figure 83 shall be a median plane, constructed from two parallel planes, which are in contact with the two surfaces of the datum feature but outside the material of the datum feature, such that their separation is maximized while they are perfectly oriented or aligned with the primary and secondary datum.

### 6.3.4 Datum based on an external cylindrical feature

**COMMENTARY ON 6.3.4**

*The datum feature consists of a non-ideal cylinder (see Figure 84).*

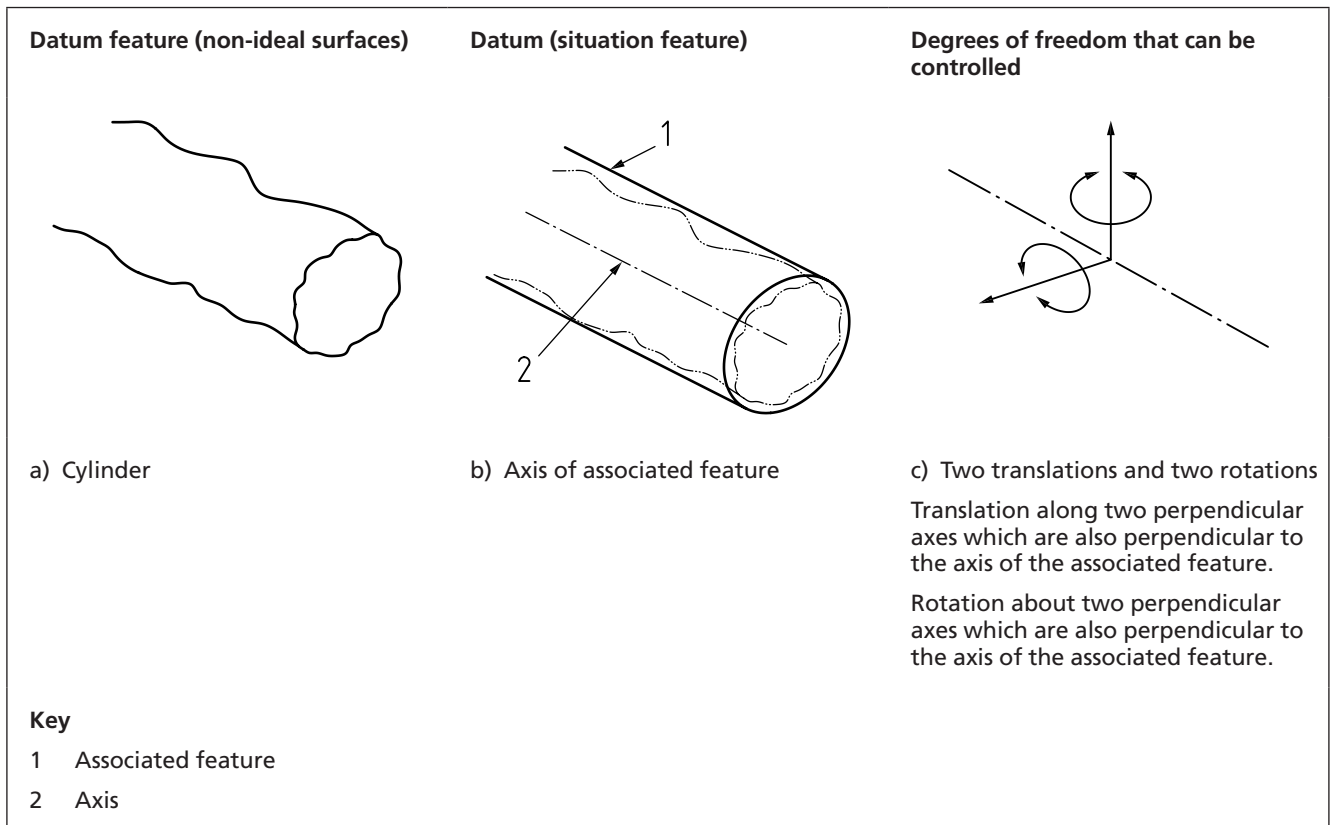
A primary datum based on the datum feature in Figure 84 shall be an axis, constructed from the minimum circumscribing cylinder which can be constructed around the datum feature.



A secondary datum based on the datum feature in Figure 84 shall be an axis, constructed from the minimum circumscribing cylinder which can be constructed around the datum feature, whilst perfectly oriented or aligned with the primary datum.

A tertiary datum based on the datum feature in Figure 84 shall be an axis, constructed from the minimum circumscribing cylinder which can be constructed around the datum feature, whilst perfectly oriented or aligned with the primary and secondary datum.

Figure 84 Datum feature consisting of a non-ideal cylinder



### 6.3.5 Datum based on an internal cylindrical feature

#### COMMENTARY ON 6.3.5

*The datum feature consists of a non-ideal cylinder.*

A primary datum based on the datum feature in Figure 84 shall be an axis, constructed from the maximum inscribing cylinder which can be constructed around the datum feature.

A secondary datum based on the datum feature in Figure 84 shall be an axis, constructed from the maximum inscribing cylinder which can be constructed around the datum feature, whilst perfectly oriented or aligned with the primary datum.

A tertiary datum based on the datum feature in Figure 84 shall be an axis, constructed from the maximum inscribing cylinder which can be constructed around the datum feature, whilst perfectly oriented or aligned with the primary and secondary datum.

### 6.3.6 Datum based on an external spherical feature

#### COMMENTARY ON 6.3.6

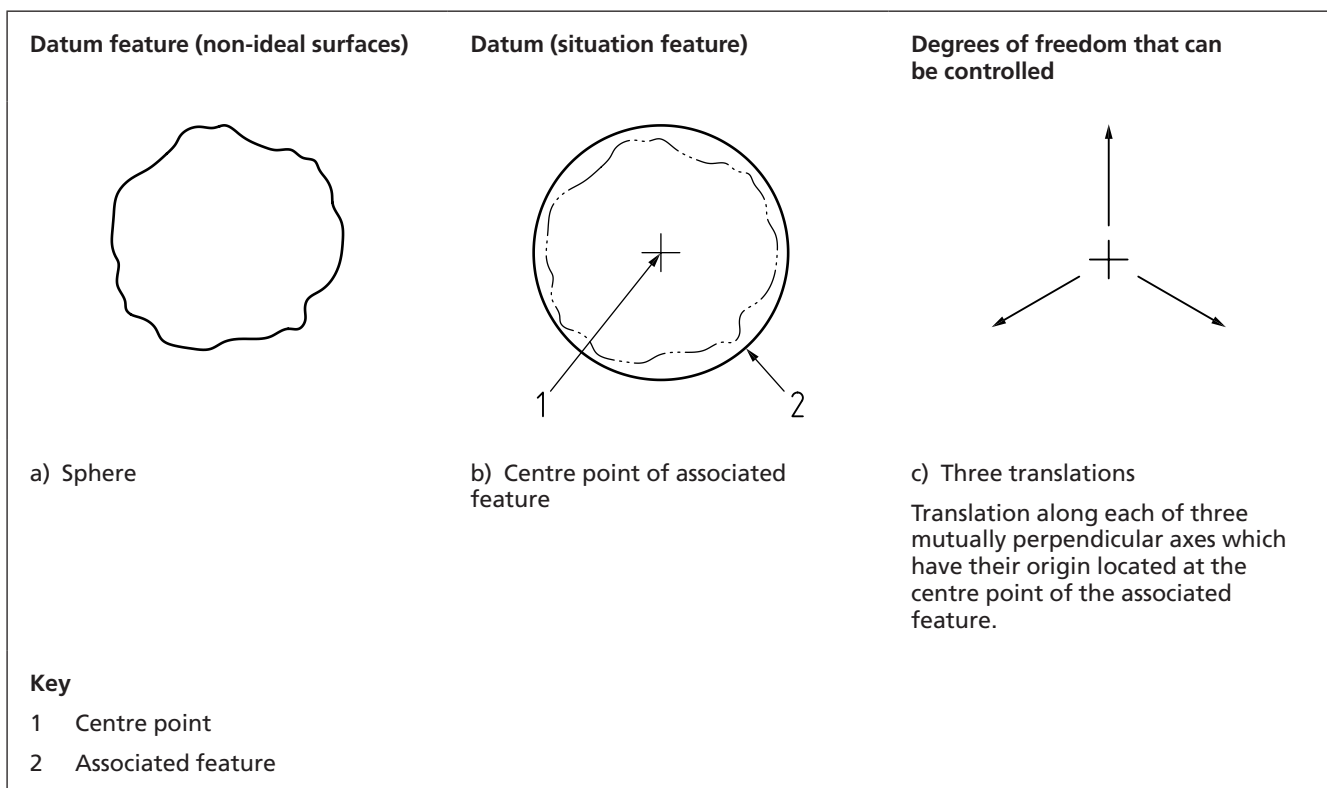
The datum feature consists of a non-ideal sphere (see Figure 85).

A primary datum based on the datum feature in Figure 85 shall be a point, constructed from the minimum circumscribing sphere which can be constructed around the datum feature.

A secondary datum based on the datum feature in Figure 85 shall be a point, constructed from the minimum circumscribing sphere which can be constructed around the datum feature, whilst perfectly aligned with the primary datum.

A tertiary datum based on the datum feature in Figure 85 shall be a point, constructed from the minimum circumscribing sphere which can be constructed around the datum feature, whilst perfectly aligned with the primary and secondary datum.

Figure 85 Datum feature consisting of a non-ideal sphere



### 6.3.7 Datum based on an internal spherical feature

#### COMMENTARY ON 6.3.7

The datum feature consists of a non-ideal sphere.

A primary datum based on the datum feature in Figure 85 shall be a point, constructed from the maximum inscribing sphere which can be constructed around the datum feature.

A secondary datum based on the datum feature in Figure 85 shall be a point, constructed from the maximum inscribing sphere which can be constructed around the datum feature, whilst perfectly aligned with the primary datum.

A tertiary datum based on the datum feature in Figure 85 shall be a point, constructed from the maximum inscribing sphere which can be constructed around the datum feature, whilst perfectly aligned with the primary and secondary datum.

### 6.3.8 External or internal cone

#### COMMENTARY ON 6.3.8

*The datum feature consists of a non-ideal cone (see Figure 86).*

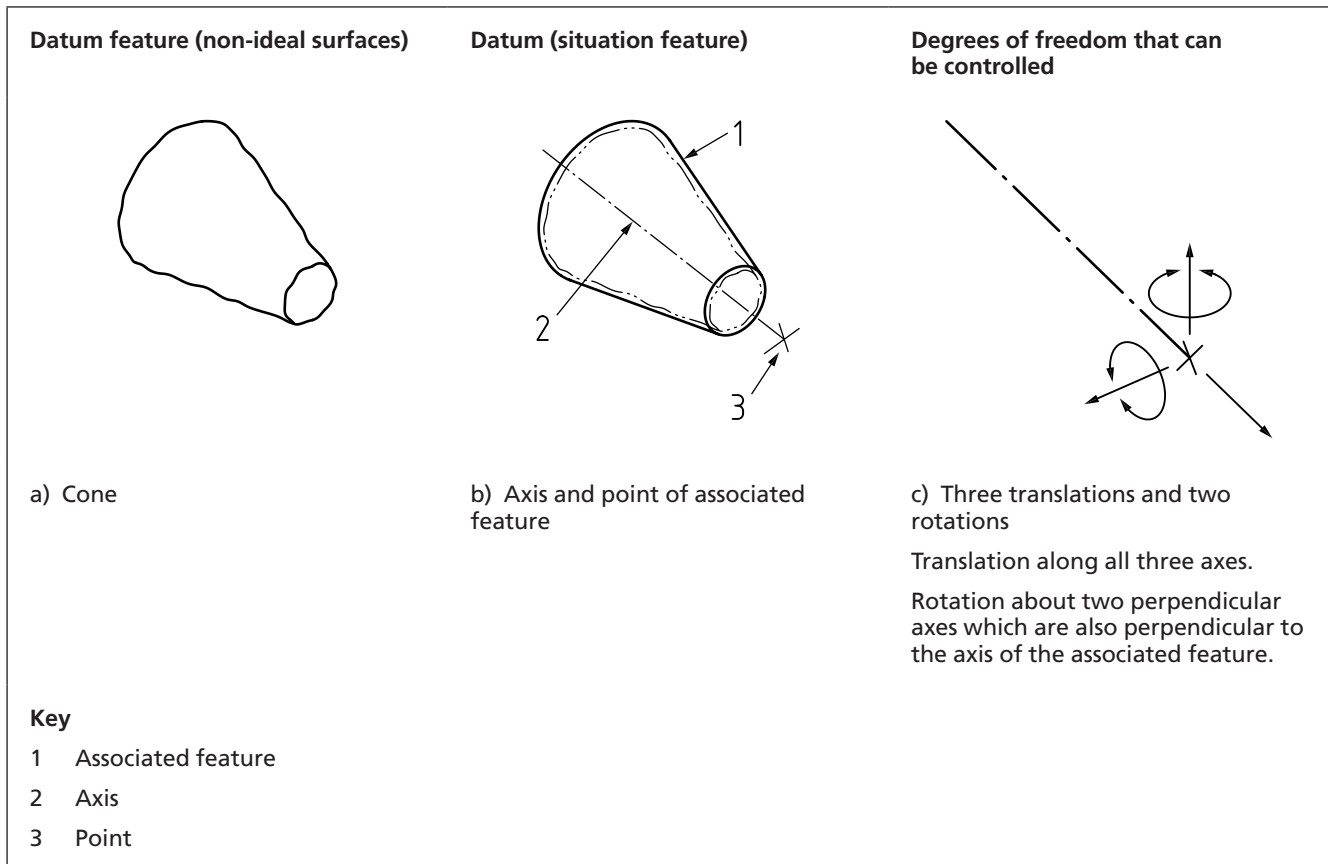
A primary datum based on the datum feature in Figure 86 shall consist of an axis and a point. The axis shall be the axis of an ideal cone, in contact with the surface of the datum feature but outside the material of the datum feature, such that its separation from the surface of the datum feature is minimized. The point shall lie on the axis. The position of the point shall be taken either at the apex of the cone or at another specified position along the axis.

A secondary datum based on the datum feature in Figure 86 shall consist of an axis and a point. The axis shall be the axis of an ideal cone, in contact with the surface of the datum feature but outside the material of the datum feature, such that its separation from the surface of the datum feature is minimized and the axis is perfectly oriented or aligned with the primary datum. The position of the point shall be taken either at the apex of the cone or at another specified position along the axis.

A tertiary datum based on the datum feature in Figure 86 shall consist of an axis and a point. The axis shall be the axis of an ideal cone, in contact with the surface of the datum feature but outside the material of the datum feature, such that its separation from the surface of the datum feature is minimized and the axis is perfectly oriented or aligned with the primary and secondary datum. The position of the point shall be taken either at the apex of the cone or at another specified position along the axis.

*NOTE If the cone is defined with a theoretically exact angle, then the angle of the associated feature is fixed at the same angle. If the cone is defined with a tolerance value for the angle, then the angle of the associated feature is variable.*

Figure 86 Datum feature consisting of a non-ideal cone



### 6.3.9 Wedge

**COMMENTARY ON 6.3.9**

*The datum feature consists of a non-ideal wedge (see Figure 87).*

A primary datum based on the datum feature in Figure 87 shall consist of a median plane and an axis. The median plane shall be constructed from two angled planes, which are in contact with the two surfaces of the datum feature but outside the material of the datum feature, such that their separation from the surfaces of the datum feature is minimized. The axis shall lie in the median plane, either at the intersection of the two angled planes of the associated feature or in a specified position parallel to that intersection.

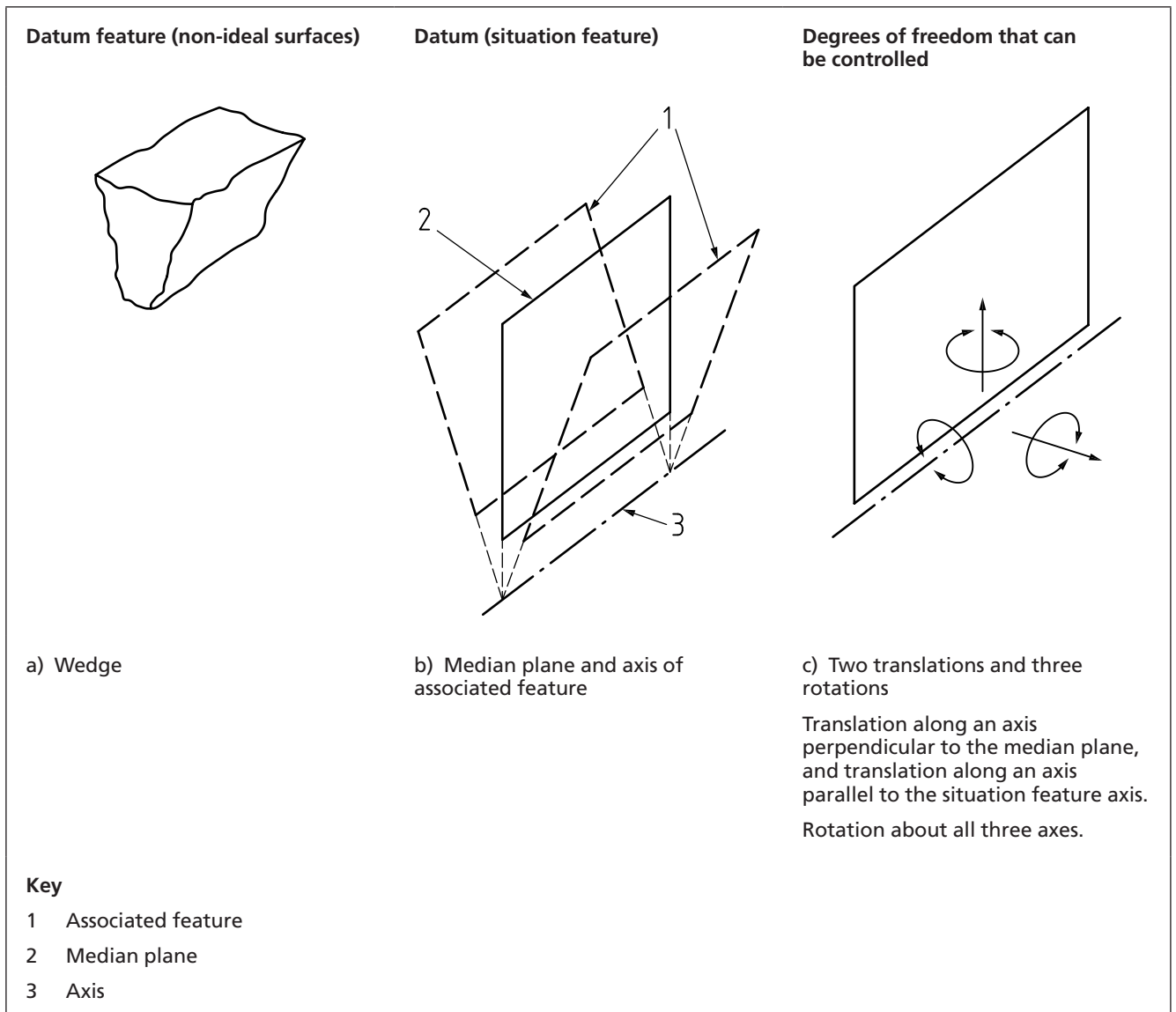
A secondary datum based on the datum feature in Figure 87 shall consist of a median plane and an axis. The median plane shall be constructed from two angled planes, which are in contact with the two surfaces of the datum feature but outside the material of the datum feature, such that their separation from the surfaces of the datum feature is minimized and the median plane is perfectly oriented or aligned with the primary datum. The axis shall lie in the median plane, either at the intersection of the two angled planes of the associated feature or in a specified position parallel to that intersection.

A tertiary datum based on the datum feature in Figure 87 shall consist of a median plane and an axis. The median plane shall be constructed from two angled planes, which are in contact with the two surfaces of the datum feature but outside the material of the datum feature, such that their separation from the surfaces of

the datum feature is minimized and the median plane is perfectly orientated or aligned with the primary and secondary datum. The axis shall lie in the median plane, either at the intersection of the two angled planes of the associated feature or in a specified position parallel to that intersection.

*NOTE* If the wedge is defined with a theoretically exact angle, then the angle between the planes of the associated feature is fixed at the same angle. If the wedge is defined with a toleranced value for the angle, then the angle between the planes of the associated feature is variable.

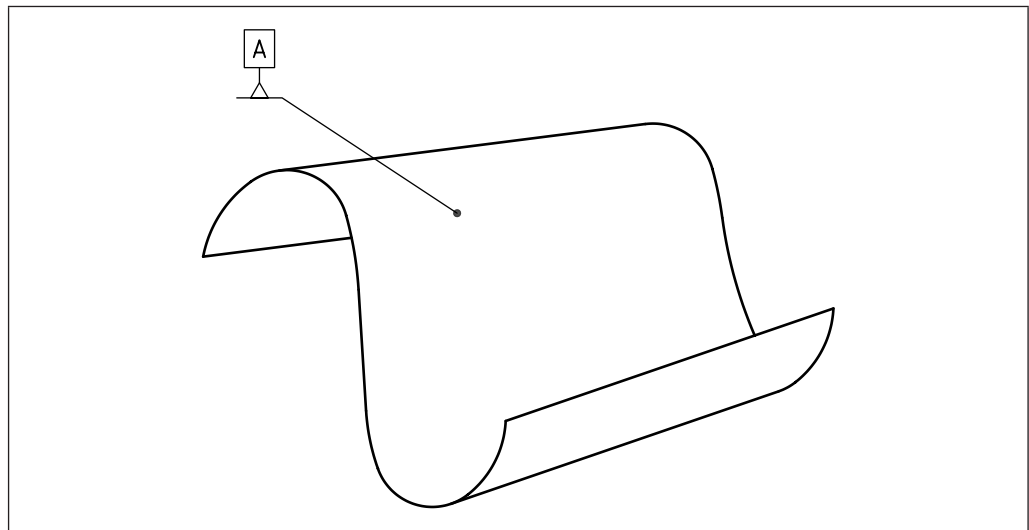
Figure 87 Datum feature consisting of a non-ideal wedge



### 6.3.10 Prismatic feature

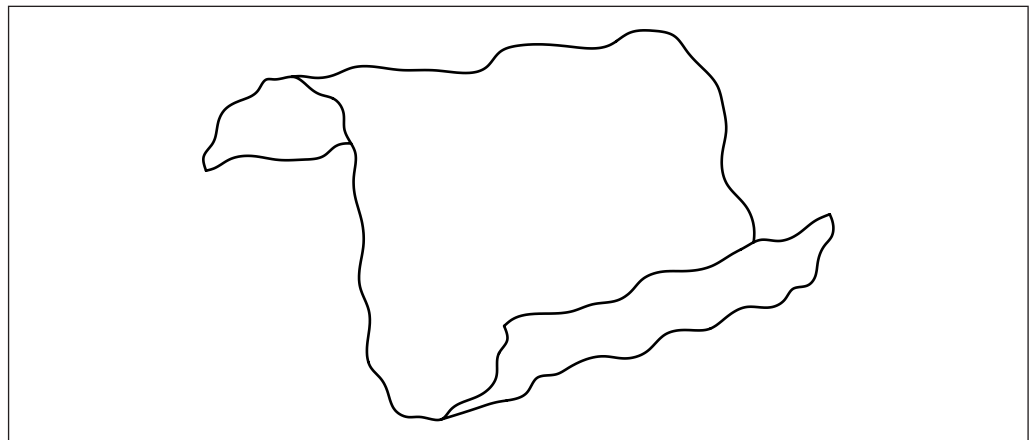
The datum shall be based on a prismatic feature as shown in Figure 88.

Figure 88 Datum for prismatic feature



The datum feature shall consist of a non-ideal prismatic surface as shown in Figure 89.

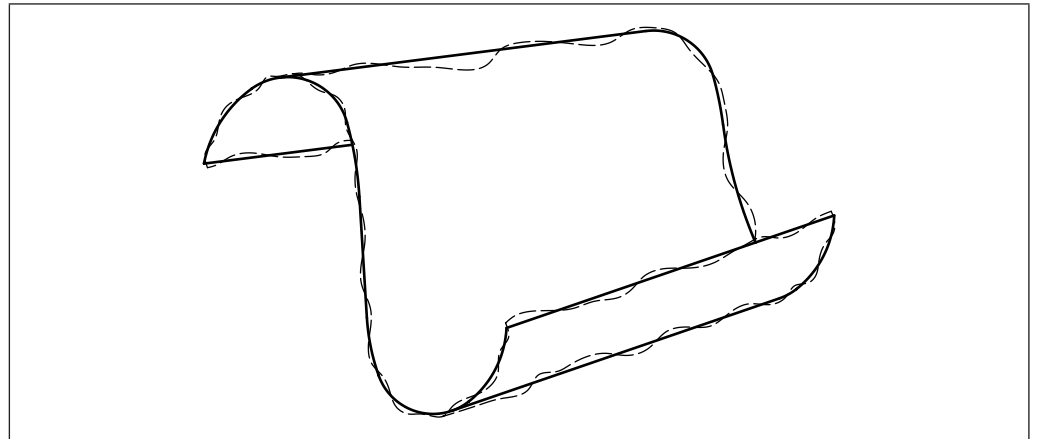
Figure 89 Non-ideal prismatic surface



The associated feature shall be constructed such that it is in contact with the surface, but outside the material of the workpiece (see Figure 90), and arranged so that the distance between the associated feature and the manufactured surface is minimized.

*NOTE* Alternatively, a non-default associate such as a least squares fit could be defined (see Annex C).

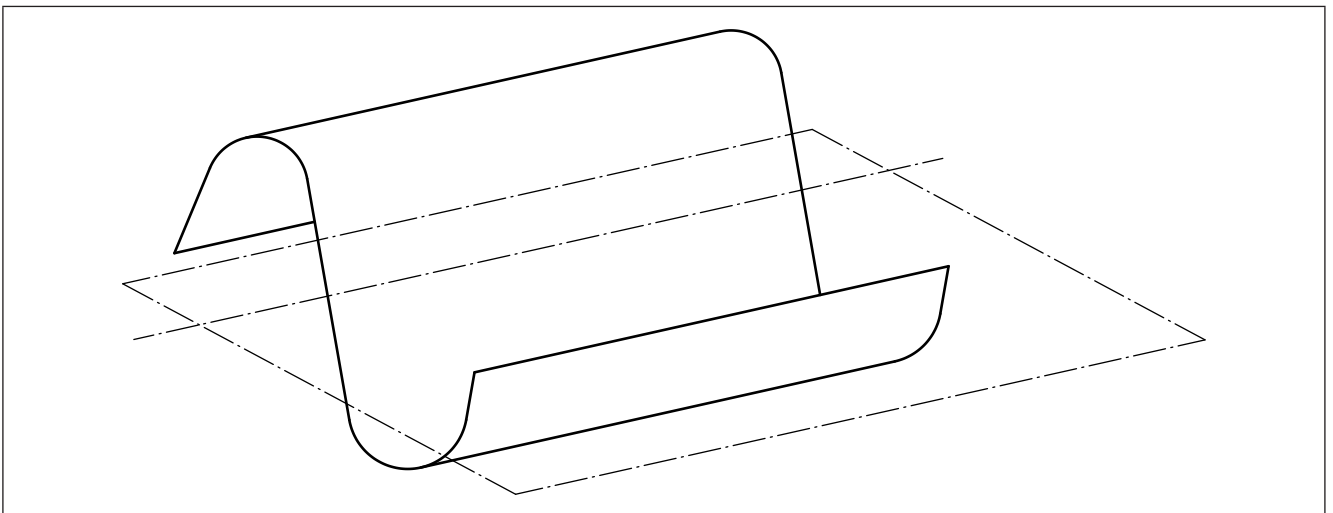
Figure 90 Associated feature of prismatic surface



The situation features for a prismatic feature shall be a plane and a line (see Figure 91).

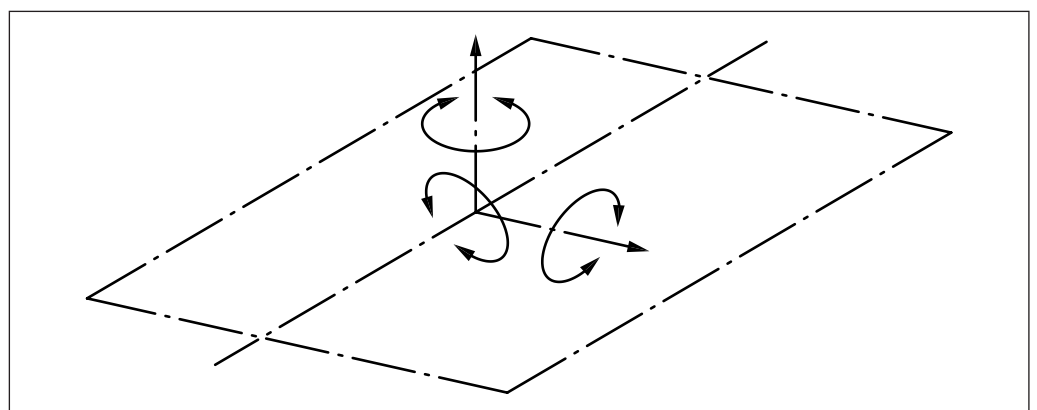
*NOTE* In many cases, neither the plane nor the line has a unique location, so the specifier can determine where these are placed relative to the surface (see 6.4).

Figure 91 Situation features for prismatic surface



A primary datum based on a prismatic feature shall control five degrees of freedom. All three rotations shall be controlled, along with translation in the two directions normal to the line situation feature (see Figure 92).

Figure 92 Degrees of freedom that can be controlled



A secondary datum based on a prismatic datum feature shall consist of a plane and an axis, constructed as for a primary datum, but with the additional requirement that the plane and line are perfectly orientated and aligned with the primary datum.

A tertiary datum based on a prismatic datum feature shall consist of a plane and an axis, constructed as for a primary datum, but with the additional requirement that the plane and line are perfectly orientated and aligned with the primary and secondary datums.

### 6.3.11 Complex surface

**COMMENTARY ON 6.3.11**

*The datum feature consists of a non-ideal surface (see Figure 93).*

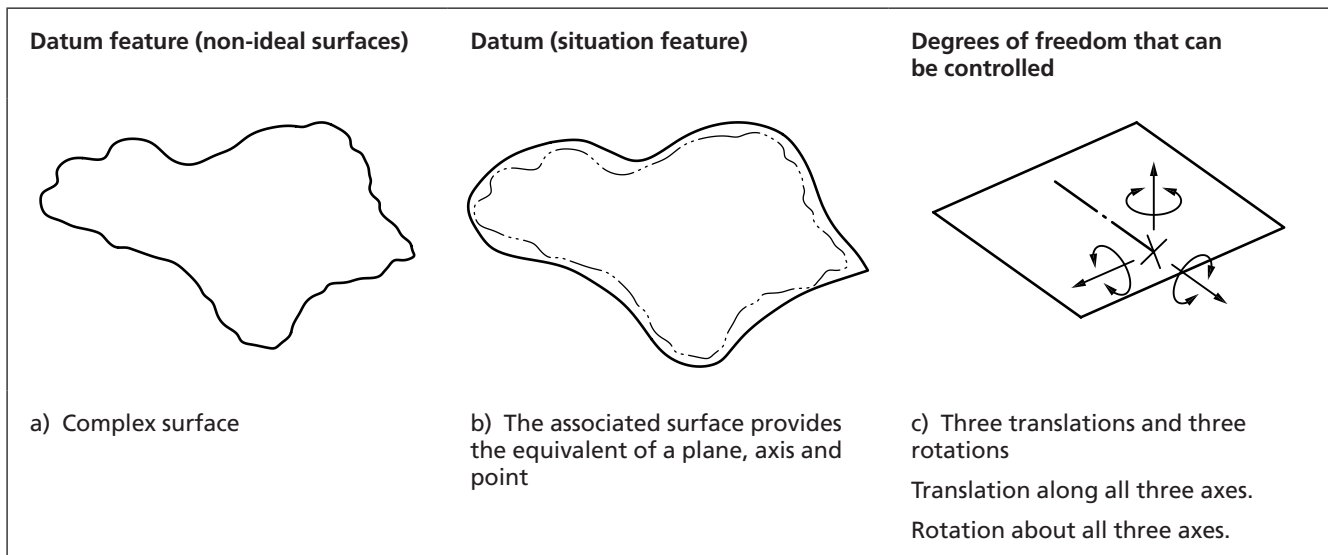
*A complex surface can be used in its entirety as a datum feature. The associated feature would be an ideal version of the surface, adjusted by varying the surface normal vectors so that it is in contact with the surface but outside the surface, such that the distance from the surface is minimized. Alternatively, a non-default associate such as a least squares fit could be defined (see Annex C).*

*This results in a single datum which is the equivalent of three situation features, a surface, a line and a point, which can lock all six degrees of freedom. This is similar to offering the datum feature up to a fixture containing a negative impression of the feature (adjustable in the surface normal direction). While the datum feature is in contact with the fixture, the workpiece is immobilized (all six degrees of freedom locked).*

*Not all inspection systems are capable of working with complex datum features in this way. Datum targets provide an alternative way of defining datums based on complex surfaces.*

A primary datum based on the datum feature in Figure 93 shall be equivalent to a plane, an axis and a point.

Figure 93 Datum feature consisting of a non-ideal complex surface



## 6.4 Indications of situation features in a technical product specification

**COMMENTARY ON 6.4**

*When a datum feature has a single situation feature, the situation feature has a unique location.*



For example, if the datum feature is a cylinder, the situation feature is a straight line, and it can only be centred in the associated cylinder; if the datum feature is a flat surface, the situation feature can only be a tangent plane.

When the datum feature has more than one situation feature, at least one of the situation features does not have a unique location.

For example, if the datum feature is a cone, the situation features are a line and a point. The line (the axis of the cone) has only one location, but the point can be taken to be anywhere along that line.

The location of the point is determined by the specifier; it can be taken as the point where a "gauge diameter" for the cone is defined or as the point at the apex of the cone.

Where necessary, the situation features shall be identified on a drawing or in a CAD model.

When these are shown on the specification, the situation features shall be represented as follows:

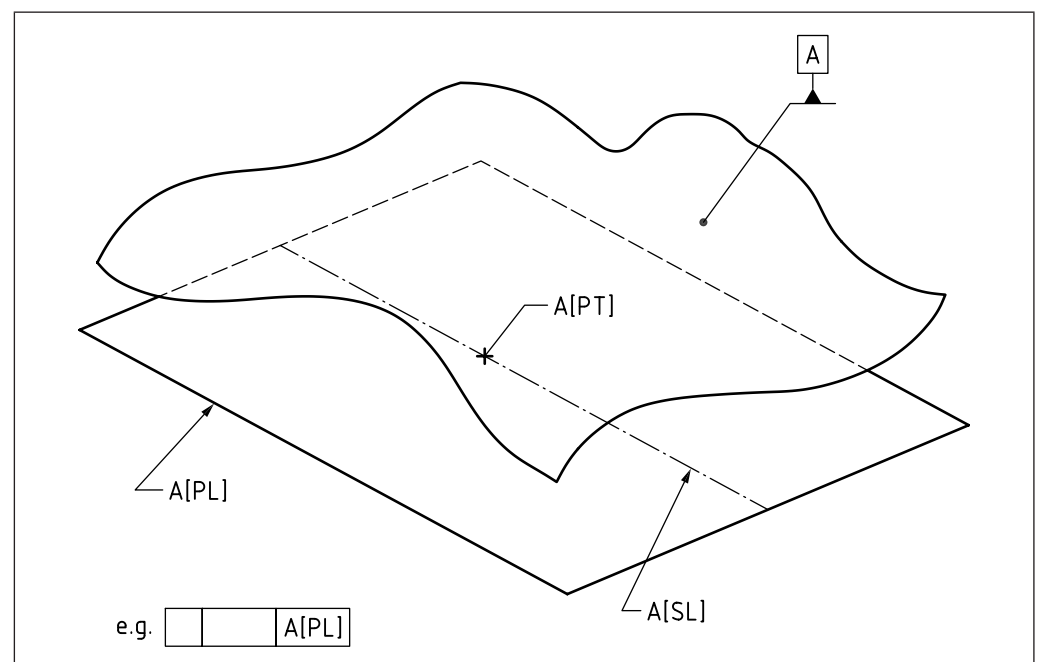
- a) point: by a cross;
- b) line: by a long-dashed double-dotted narrow line (line type 05.1 from BS ISO 128-24:1999);
- c) plane: when shown edge on, by a line [see b)] or by a rectangular plane outlined with a long-dashed double-dotted narrow line.

The situation features shall be labelled with an identifier as follows:

- 1) point: by an identifier consisting of the name of the datum, followed by PT in square brackets;
- 2) line: by an identifier consisting of the name of the datum, followed by SL in square brackets (see Figure 94);
- 3) plane: by an identifier consisting of the name of the datum, followed by PL in square brackets (see Figure 94).

Where necessary, these identifiers shall be shown in more than one drawing view.

Figure 94 Example identifiers for situation features



NOTE 2 See Annex E for further information regarding implementation in CAD.

## 6.5 Identifying datum features: Placement of the datum feature indicator

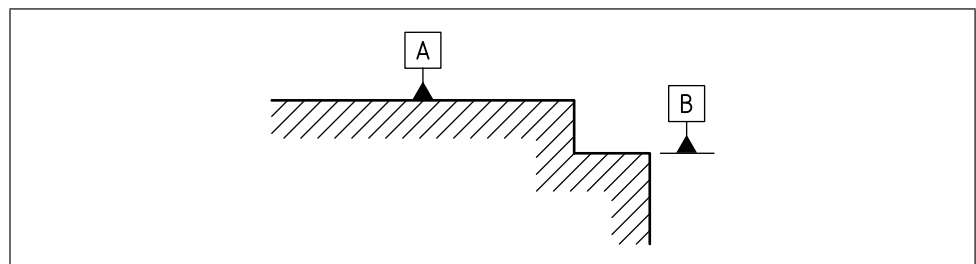
### 6.5.1 General

Where a datum is based on a single datum feature, the datum feature shall be identified with a datum feature indicator.

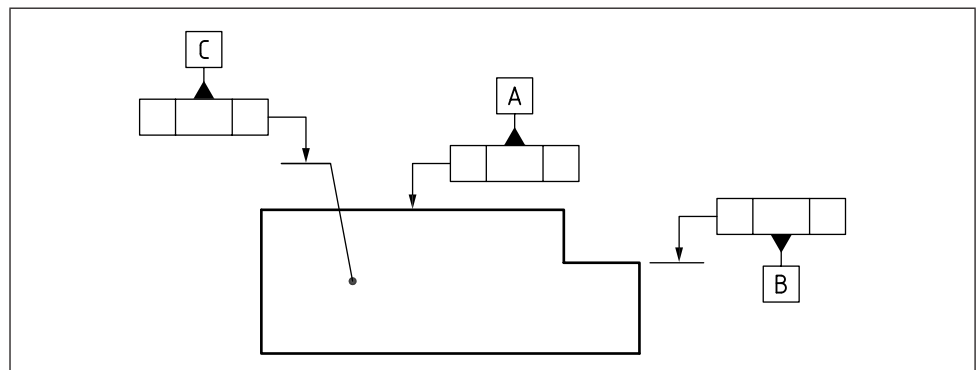
*NOTE The datum is based on the entire surface of the datum feature, unless otherwise indicated. If the datum is based on part of the datum feature, datum targets are used (see 6.8.1).*

If the feature is not a feature of size, the datum feature indicator shall be placed in one of the following positions.

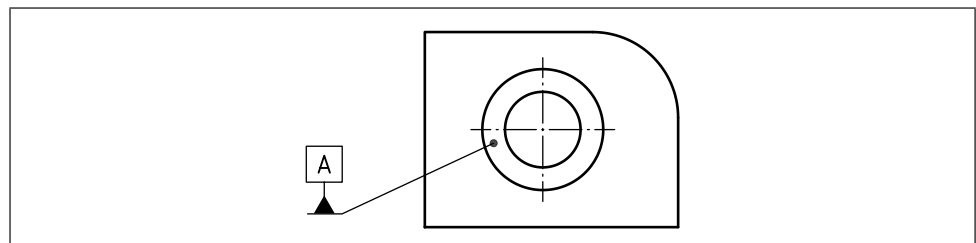
- a) Attached to an outline, or an extension line from an outline, representing the feature in profile.



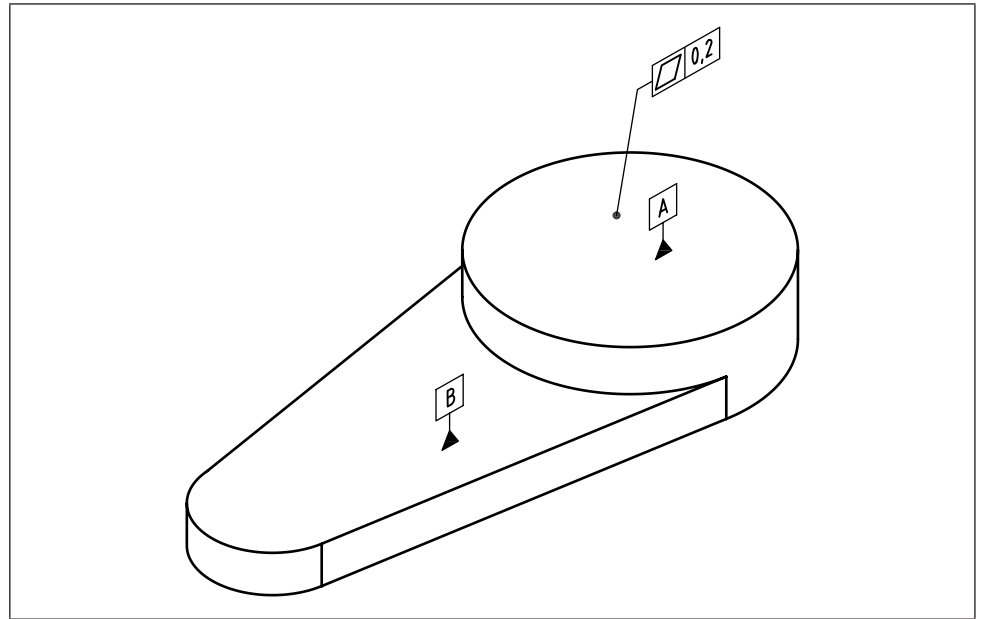
- b) Attached to a tolerance frame which is attached to the feature.



- c) Attached to a visible surface with a leader line ending in a filled dot on the surface.



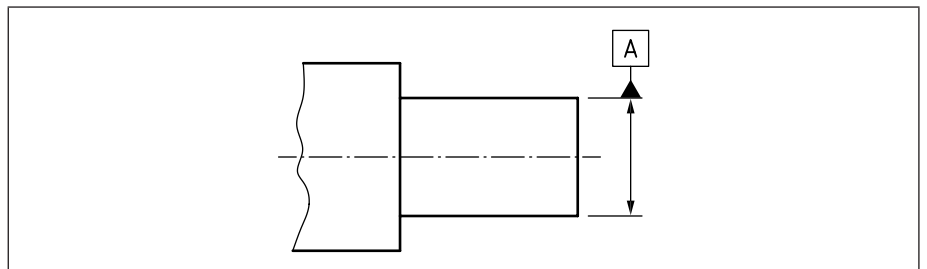
- d) Attached to a visible surface on a 3D TPS.



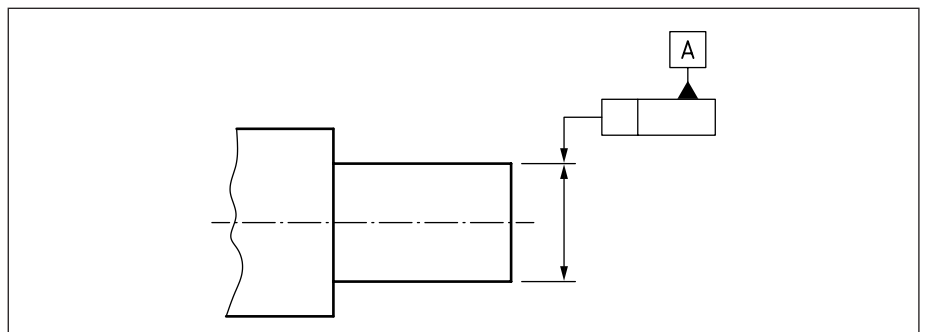
If the datum feature is a feature of size, the datum feature indicator shall be placed in one of the following positions.

- 1) In line with the dimension line for the size dimension of the feature.

*NOTE* The datum feature indicator is placed in line with the size dimension to unambiguously identify the feature that the datum is to be derived from.



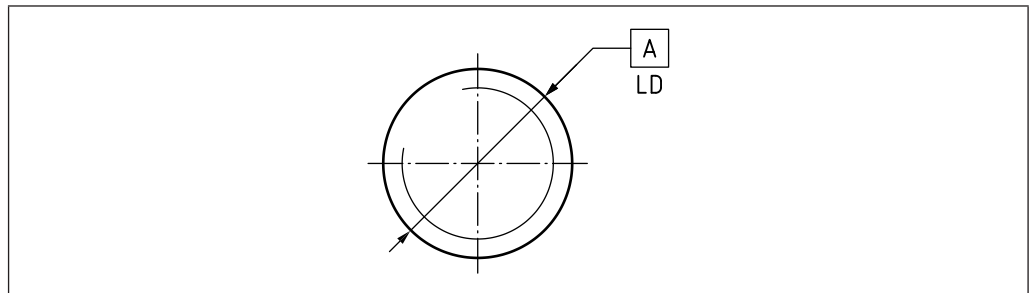
- 2) Attached to a tolerance frame which has its leader line in line with the dimension line for the size dimension of the feature.



### 6.5.2 Datums based on threaded features, gears or splines

If the datum feature is a threaded feature, then it shall be treated like a cylindrical feature of size. The datum feature indicator shall be placed in line with the thread dimension, or attached to a tolerance frame which is attached in line with the

thread dimension. By default, the datum shall be a datum axis based on the pitch cylinder of the thread. The datum definition can be altered by placing the MD (major diameter) or LD (minor diameter) modifier adjacent to the datum feature indicator (see BS EN ISO 1101).



If the datum feature is a cylindrical gear form or a splined cylindrical feature, then it shall be treated like a cylindrical feature of size. The datum feature indicator shall be placed in line with the size dimension, or attached to a tolerance frame which is attached in line with the size dimension for the feature.

There is no default definition of the datum axis based on a gear form or spline. The datum definition shall be completed by placing the PD (pitch diameter), MD or LD modifier adjacent to the datum feature indicator (see BS EN ISO 1101).

*NOTE* An example of a datum based on a single datum feature is given in Table 14.

Table 14 Example: single datum

Indication of datum feature	Indication of datum in tolerance frame	Illustration of the meaning	Invariance class and situation feature (see 7.5)	Datum
			Cylindrical Axis of associated cylinder	
			Planar Associated plane	

**Key**

- 1 Associated feature (without orientation constraint)
- 2 Straight line which is the situation feature of the associated cylinder (its axis)
- 3 Plane which is the situation feature of the associated plane (the associated plane itself)

*NOTE* Association for single datums is described in BS EN ISO 5459:2011, Annex A.

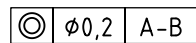
## 6.6 Common datums

### 6.6.1 General

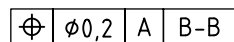
#### COMMENTARY ON 6.6.1

A common datum is a single datum based on more than one datum feature.

A common datum shall be identified by listing the individual datum feature identifiers in a single datum compartment of the tolerance frame. The individual datum feature identifiers shall be separated by a hyphen, e.g.:



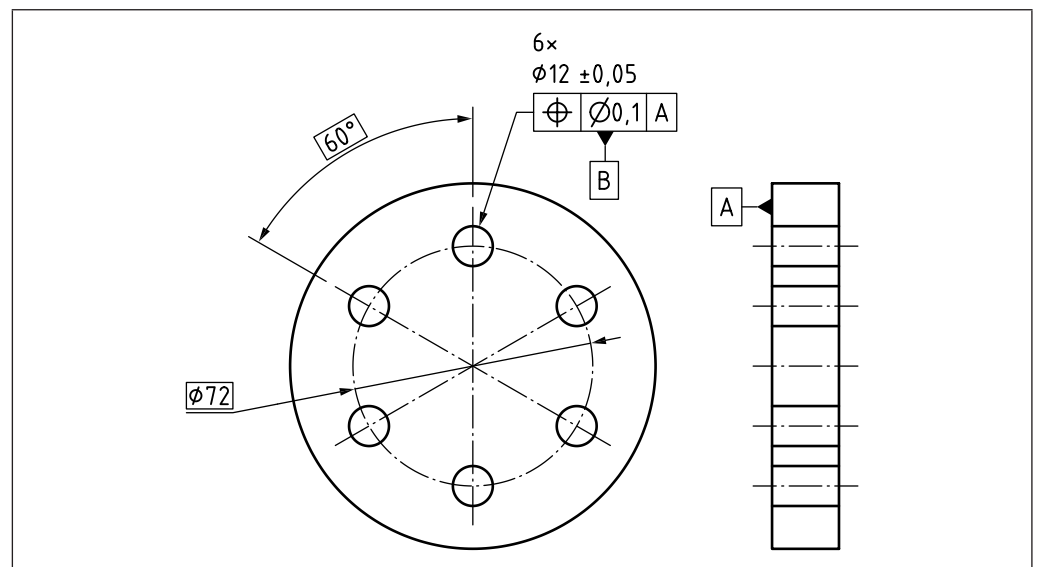
Where a common datum is based on a group of identical features, which are identified with a single datum feature indicator, as in Figure 95, then the datum feature identifier shall be shown twice, separated by a hyphen, e.g.:



When a common datum is used, the relationship between the individual datum features shall be tolerated.

When a common datum is constructed, the theoretically exact relationships between the individual datum features shall also apply to the associated features which are used to construct the datum.

Figure 95 Common datum established by a group of identical features



### 6.6.2 Example 1: Common datums based on two coaxial cylinders

Where a single datum axis defined by two coaxial, cylindrical features used simultaneously (as shown in Figure 96) is a primary datum, it shall consist of:

- a single axis constructed from the minimum circumscribing cylinder which can be constructed around datum feature A; and
- the minimum circumscribing cylinder which can be constructed around datum feature B simultaneously,

where the two minimum circumscribing cylinders are additionally constrained to be coaxial with each other (see Figure 97).

Figure 96 Common datum established from two coaxial cylinders

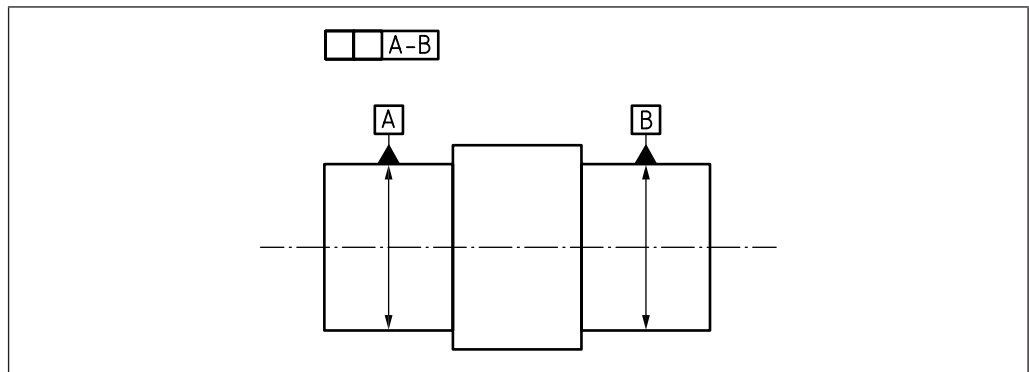
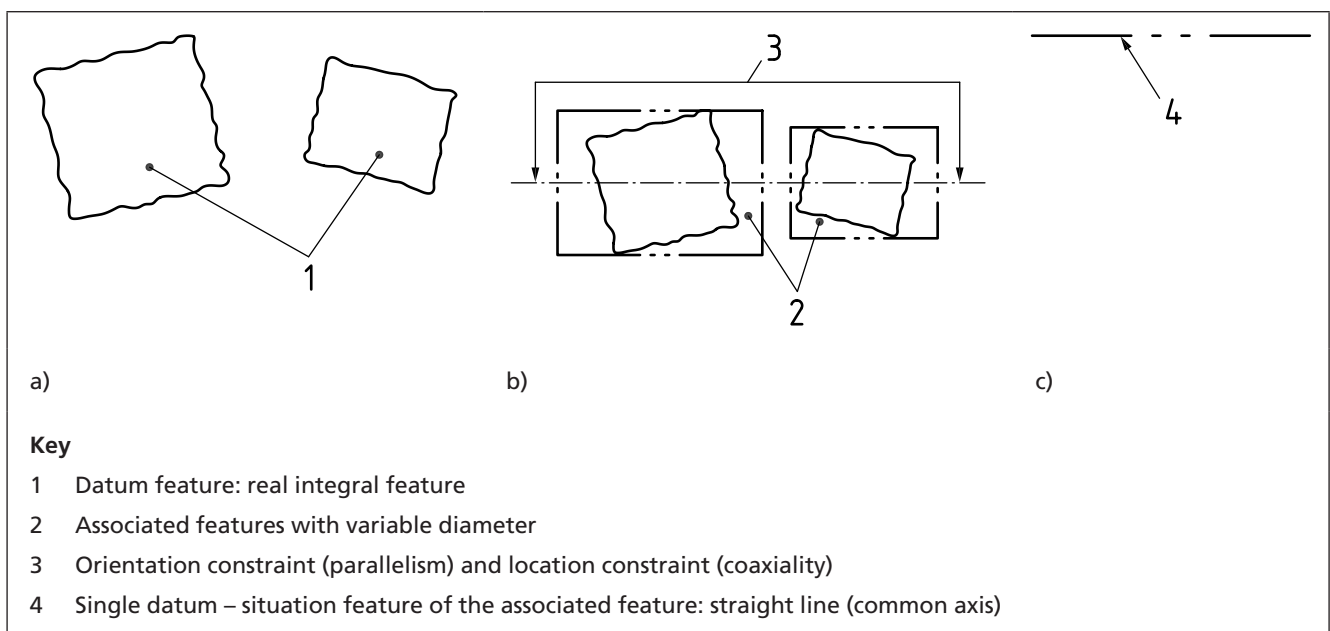


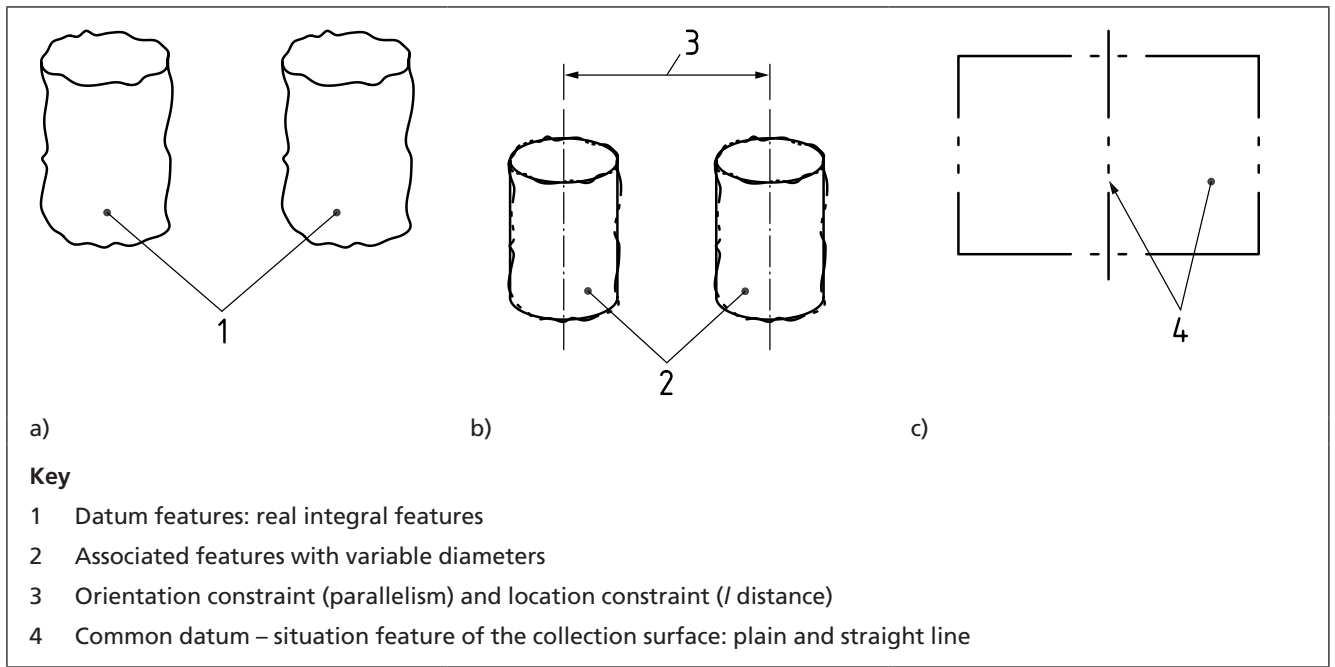
Figure 97 Establishing a common datum from two coaxial cylinders



### 6.6.3 Example 2: Common datums based on two parallel cylinders

Where a single datum defined by two parallel, cylindrical holes is a primary datum, a maximum inscribing cylinder shall be constructed for each of the two holes simultaneously, with the additional constraint that the two inscribing cylinders shall remain parallel with each other, and a fixed distance ( $l$ ) apart. The datum shall consist of two situation features, an axis and a plane. The axis shall be a mean between the axes of the two inscribing cylinders, and the plane shall be a plane through that axis and the axis of either one of the inscribing cylinders (see Figure 98).

Figure 98 Establishing a common datum from two parallel cylinders



**6.6.4 Example 3: Common datums based on a group of cylinders**

Where a single datum defined by a group of five, nominally identical cylindrical holes (as shown in Figure 99) is a primary datum, a maximum inscribing cylinder shall be constructed for each of the five holes simultaneously, with the additional constraint that the five inscribing cylinders shall remain parallel with each other and centred on a pitch circle of diameter  $\varnothing d$  at  $72^\circ$  increments. The datum shall consist of two situation features, an axis and a plane. The axis shall be a mean between the axes of the five inscribing cylinders, and the plane shall be a plane through that axis and the axis of one of the inscribing cylinders (see Figure 100).

*NOTE These principles can be equally applied to non-parallel cylinders.*

Figure 99 **Pattern of five cylinders: input for reading (drawing indication) and for writing (design intent)**

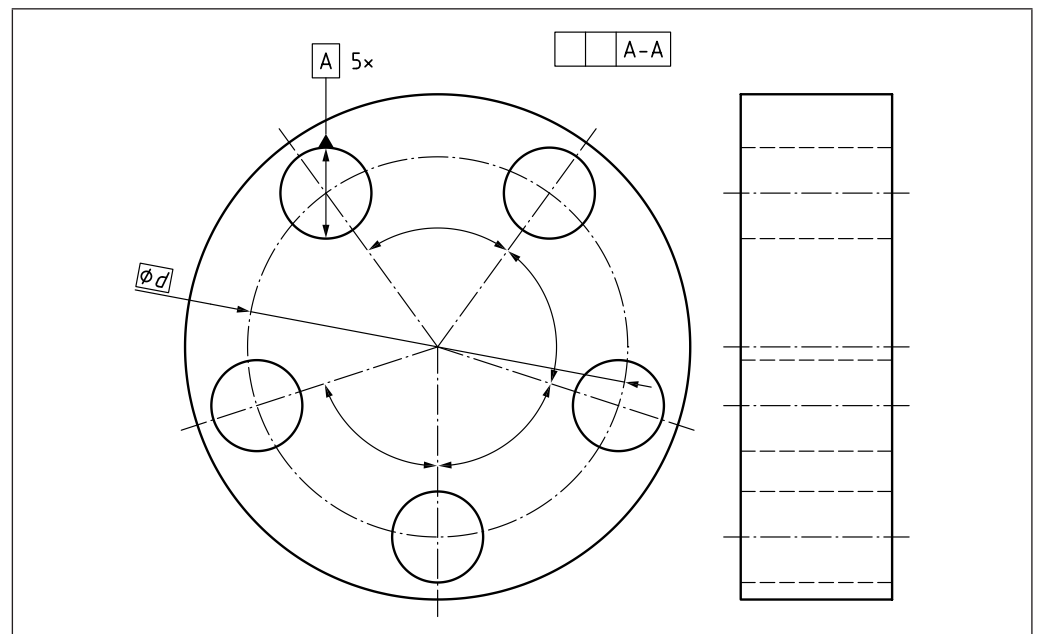
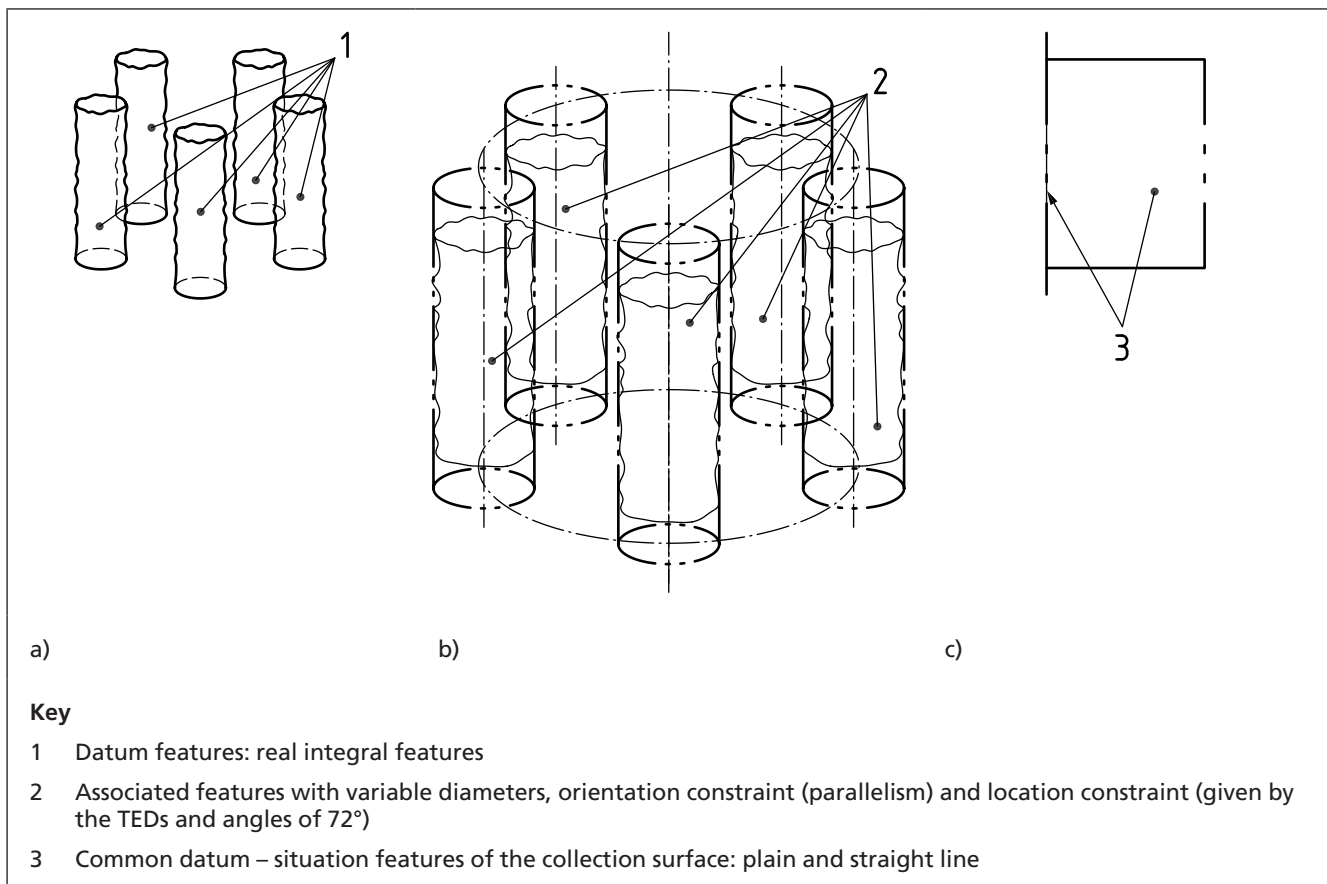


Figure 100 Establishing a common datum from a pattern of five cylinders



### 6.6.5 Association for common datums

#### COMMENTARY ON 6.6.5

*The association method for common datums requires that a collection of ideal single surfaces be fitted simultaneously (in one step) to several non-ideal surfaces.*

The process of association for common datums shall include location and orientation constraints between the different associated features. These constraints shall be:

- a) the new intrinsic characteristics defined by the collection of the features;
- b) either defined explicitly or implicitly by TEDs (implicit orientation constraint: 0°, 90°, 180°, 270° and implicit location constraint: 0 mm).

The internal constraints for association described for single datums are also applicable for common datums, but complementary constraints (e.g. coplanarity, coaxiality) between the associated features shall be added.

### 6.6.6 Default association criteria

The following constraints for establishing a common datum shall be applied to each associated feature included in the collection defined by the common datum indication:

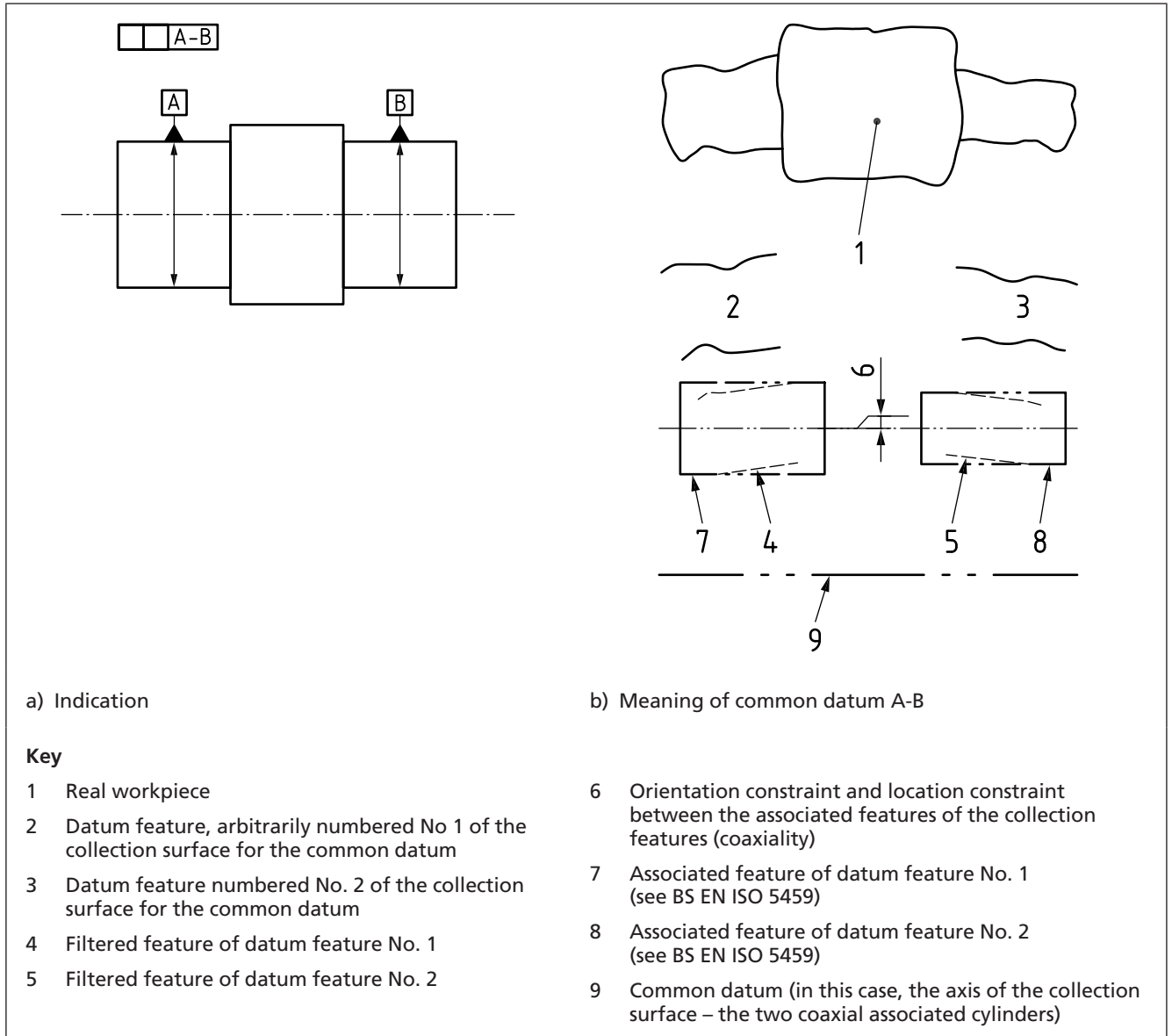
- a) be outside the material of its corresponding filtered feature;
- b) respect the orientation and location constraints defining the relationship between the nominal features in the collection (indicated by an explicit or implicit TED), while taking into account any modifiers (see 6.9.2, Figure 118).



*NOTE 1 The objective function is to simultaneously minimize the maximum distance normal to the associated feature between each associated feature and its filtered feature.*

*NOTE 2 Figure 101 illustrates the process used to establish a common datum from two surfaces nominally cylindrical and coaxial.*

Figure 101 Association for a common datum based on two coaxial cylinders



## 6.7 Datum systems and the six degrees of freedom

### COMMENTARY ON 6.7

*A datum system is a set of two or three datums used together (see 6.2.4).*

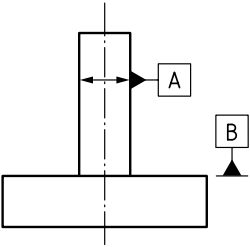
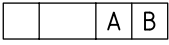
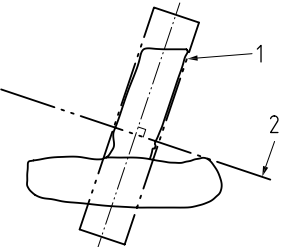
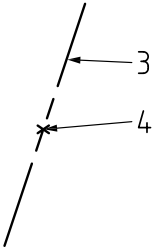
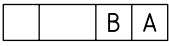
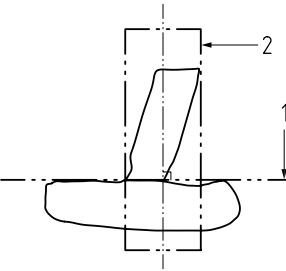
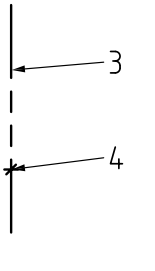
In a datum system, the datums shall be used to lock some or all of the six degrees of freedom available to the tolerance zone.

**NOTE 1** The effect of datums can be modified with the "orientation only" symbol (see 6.9.1):

- a) the primary datum locks whichever degrees of freedom it can lock;
- b) the secondary datum locks whichever degrees of freedom it can lock, and which have not already been locked by the primary datum;
- c) the tertiary datum locks whichever degrees of freedom it can lock, and which have not already been locked by the primary and secondary datum.

**NOTE 2** Table 15 and Table 16 give examples of datum systems.

Table 15 Examples: datum systems

Indication of datum feature	Indication of datum in tolerance frame	Meaning on workpiece	Resulting common datum or datum system	Degrees of freedom controlled
				Five degrees of freedom locked. Rotation about the axis (item 3) not locked
				

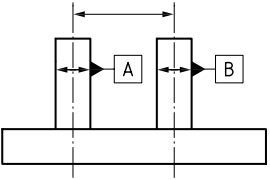
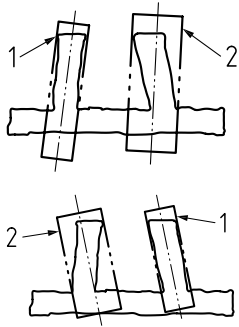
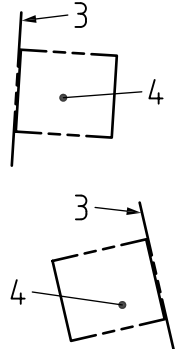
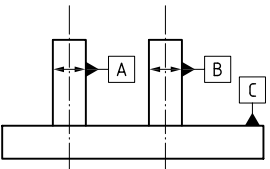
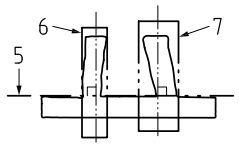
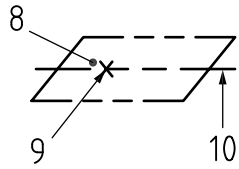
**Key**

- 1 First associated feature without orientation constraint
- 2 Second associated feature with orientation constraint from the first associated feature
- 3 Straight line which is the situation feature of the associated cylinder (its axis)
- 4 Point of intersection between the straight line and the plane

**NOTE 1** The orientation and location of datums are different, depending on the datum indications in the tolerance frame.

**NOTE 2** Association for single datums is described in BS EN ISO 5459:2011, Annex A.

Table 16 Examples: datum systems

Indication of datum feature	Indication of datum in tolerance frame	Meaning on workpiece	Resulting common datum or datum system	Degrees of freedom that can be locked
	<div style="border: 1px solid black; padding: 2px; display: inline-block; margin-bottom: 10px;"> <span style="border: 1px solid black; padding: 0 5px;">A</span> <span style="border: 1px solid black; padding: 0 5px;">B</span> </div> <div style="border: 1px solid black; padding: 2px; display: inline-block;"> <span style="border: 1px solid black; padding: 0 5px;">B</span> <span style="border: 1px solid black; padding: 0 5px;">A</span> </div>			Five degrees of freedom locked. Translation along the axis (item 3) not locked
	<div style="border: 1px solid black; padding: 2px; display: inline-block;"> <span style="border: 1px solid black; padding: 0 5px;">C</span> <span style="border: 1px solid black; padding: 0 5px;">A</span> <span style="border: 1px solid black; padding: 0 5px;">B</span> </div>			All six degrees of freedom locked

**Key**

- 1 First associated cylinder without constraint
- 2 Second associated cylinder with parallelism constraint from the first associated feature
- 3 Straight line which is the axis of the first associated cylinder
- 4 Plane including the axes of the two associated cylinders
- 5 First associated feature without a constraint
- 6 Second associated feature with a perpendicularity constraint from the first associated feature
- 7 Third associated feature with a perpendicularity constraint from the first associated feature (and parallelism constraint from the second feature)
- 8 Plane which is the first associated feature
- 9 Point of intersection between the plane and the axis of the second associated feature
- 10 Straight line which is the intersection between the associated plane and the plane containing the two axes

*NOTE 1 The orientation and location of datums are different depending on the datum indication in the tolerance frame. Not all possibilities for establishing the datums are covered.*

*NOTE 2 Association for single datums is described in BS EN ISO 5459:2011, Annex A.*

## 6.8 Datum targets

### 6.8.1 General

When a datum is based on part of a datum feature, then datum targets shall be used to identify the part of the datum feature to be used.

Where applicable, datum targets shall be used to:

- a) simulate the interface between the workpiece and other components of an assembly;
- b) simulate the interface between the workpiece and a fixture (frequently used with cast or forged components, which are held in fixtures for machining operations);
- c) identify points to be used in workpiece verification.

Where applicable, a datum target shall as necessary take the form of:

- 1) a point;
- 2) a line; or
- 3) an area.

A datum target shall be indicated by a datum target indicator constructed from:

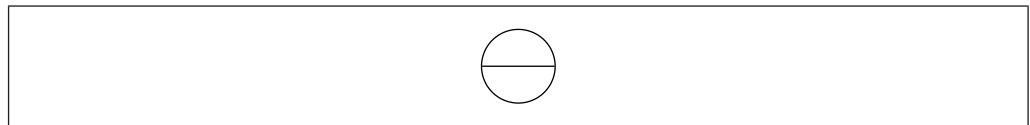
- i) a datum target frame;
- ii) a datum target symbol; and
- iii) a leader line linking the two symbols (directly or through a reference line).

Where necessary, the same datum target shall be indicated on several appropriate views in order to provide an unambiguous definition (see Figure 112, Figure 113, Figure 114 and Figure 115).

### 6.8.2 Datum target frame

The datum target frame shall be a circle, divided into two compartments by a horizontal line (see Figure 102). The lower compartment shall be reserved for the datum feature identifier, followed by a digit (from 1 to  $n$ ), corresponding to the datum target number. The upper compartment shall be reserved for additional information, such as dimensions of the target area.

Figure 102 **Single datum target frame**

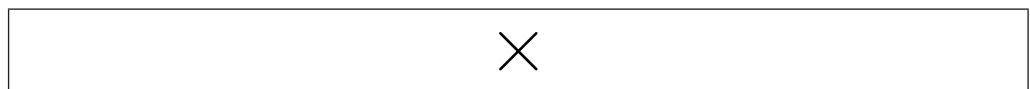


### 6.8.3 Datum target symbol

The datum target symbol indicates the type of datum target.

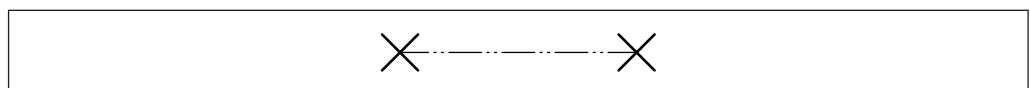
A datum target point shall be identified with a cross (see Figure 103).

Figure 103 **Datum target point**



A datum target line shall be indicated by a long-dashed double-dotted narrow line (type 05.1 of BS ISO 128-24:1999). If the line is open, each end shall be terminated by a cross (see Figure 104). Where applicable, this line shall be straight, circular or a line of any shape.

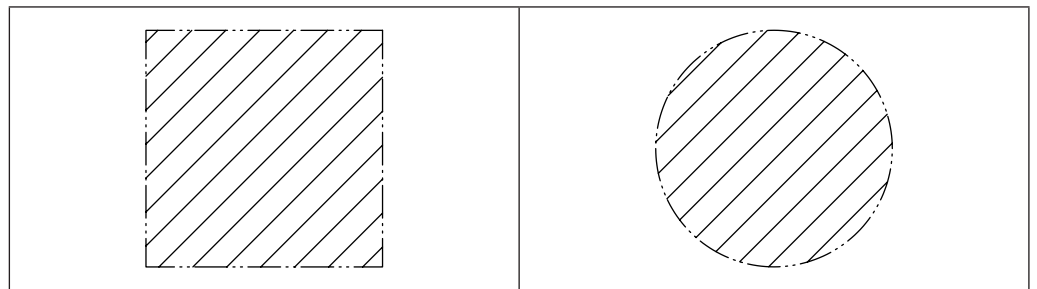
Figure 104 **Open datum target line**



A datum target area shall be indicated with an outline using a long-dashed double-dotted narrow line (type 05.1 of BS ISO 128-24:1999), and cross-hatched (see Figure 105).

*NOTE For 3D TPS a shaded surface can be used (see BS ISO 16792:2015, 10.3.4).*

Figure 105 Datum target area



6.8.4 Leader line

The datum target frame shall be connected directly, or through a reference line, to the datum target symbol by a leader line terminated with or without an arrow or a dot (see Figure 106, Figure 107 and Figure 108).

Figure 106 Indicator for single datum target point

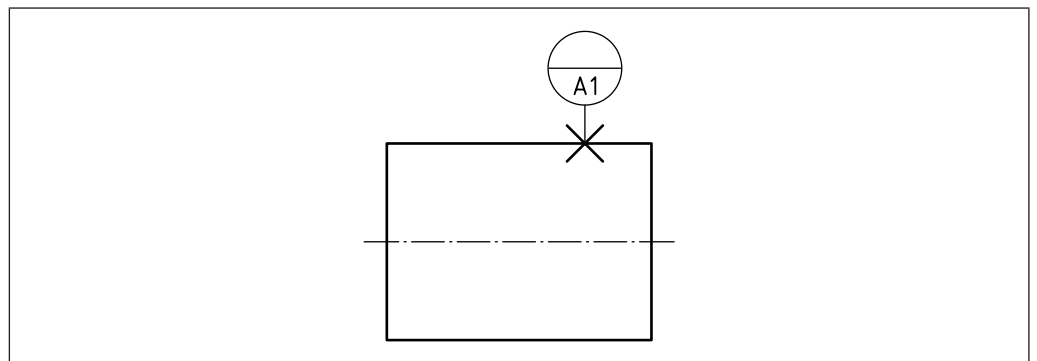


Figure 107 Indicator for single datum target line

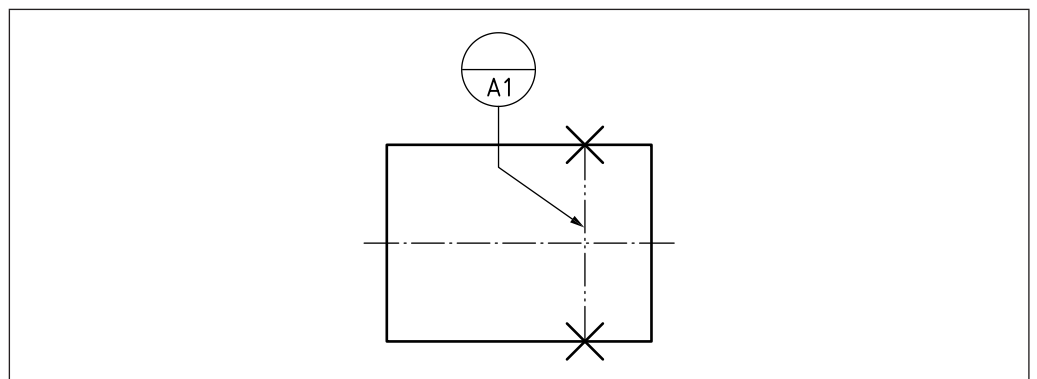
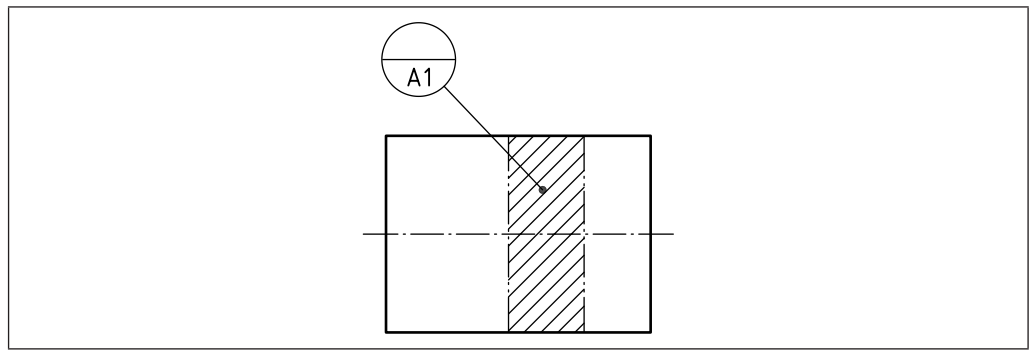


Figure 108 Indicator for single datum target surface

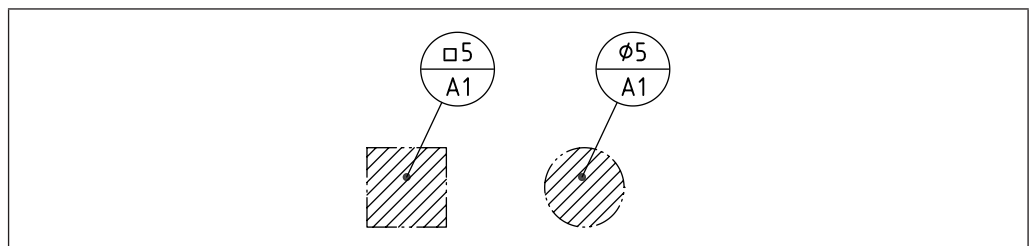


NOTE The orientation of the leader line connecting the frame with the datum target symbol is unimportant.

### 6.8.5 Datum target areas

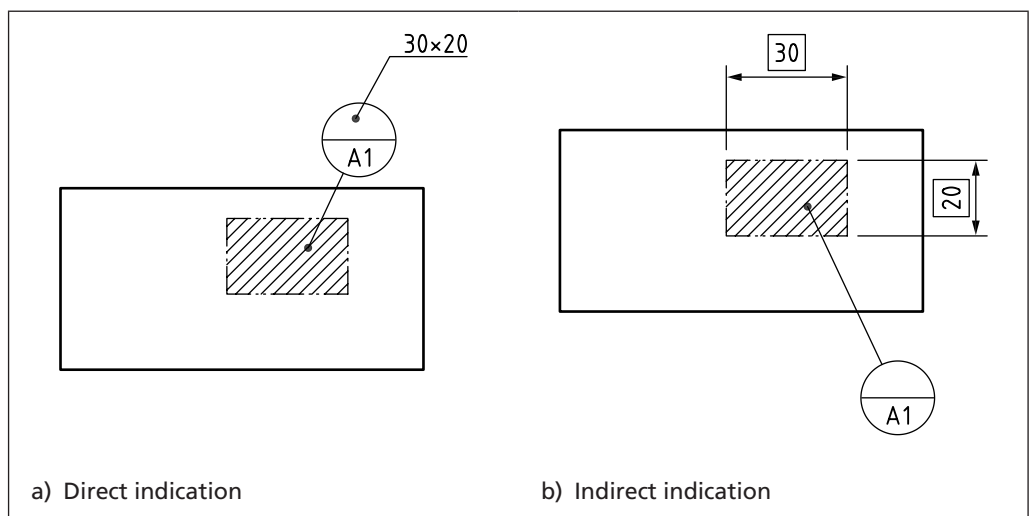
The upper compartment of the datum target frame shall only be used when defining a datum target area (see Figure 109).

Figure 109 Indicator for single datum target area



Where applicable, the size of the area shall, as appropriate, be indicated in the upper compartment or using dimensions elsewhere on the specification (in which case the upper compartment remains blank) (see Figure 110).

Figure 110 Direct and indirect indication for single datum target area



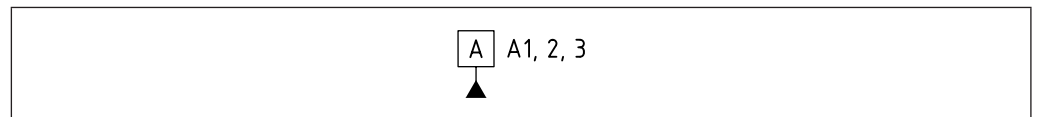
NOTE The dimensions defining the size of the datum target area are theoretically exact.

### 6.8.6 Datum feature indicators used with datum targets

If a single datum feature is established from one or more datum targets belonging to only one surface, then the datum feature identifier identifying the surface shall be repeated close to the datum indicator, followed by the list of numbers (separated by commas) identifying the targets (see Figure 111). Each individual datum target shall be identified by a datum target indicator indicating the datum feature identifier, the number of the datum target and, if applicable, the dimensions of the datum target.

*NOTE 1* The list of datum targets can be placed anywhere adjacent to the datum feature identifier.

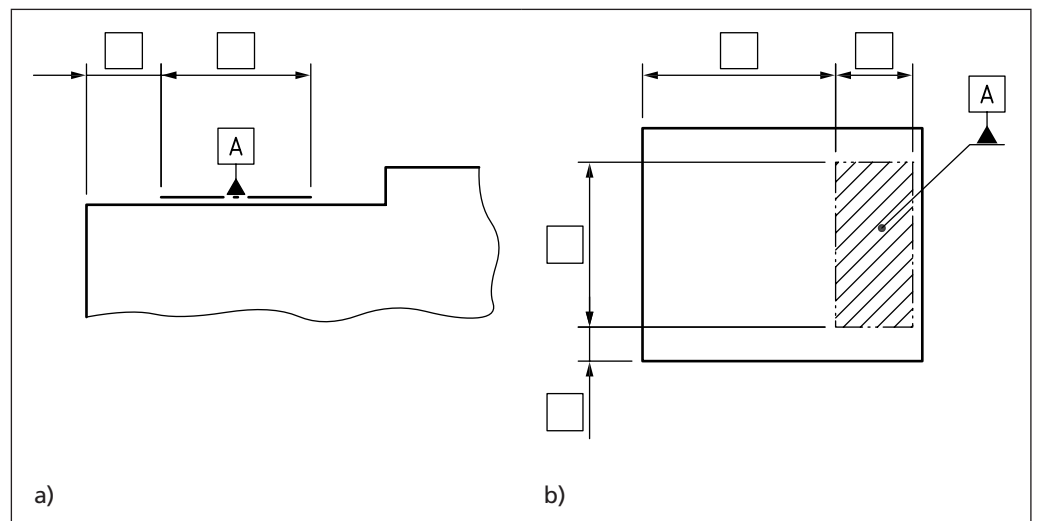
Figure 111 Indication of datums established from datum targets



*NOTE 2* In the case of a large number of datum targets (e.g. when defining a datum for a large, flexible panel), an abbreviated indication, such as "A1-20", is acceptable.

*NOTE 3* If there is only one datum target, the drawing indication may be simplified by placing the datum indicator as shown in Figure 112.

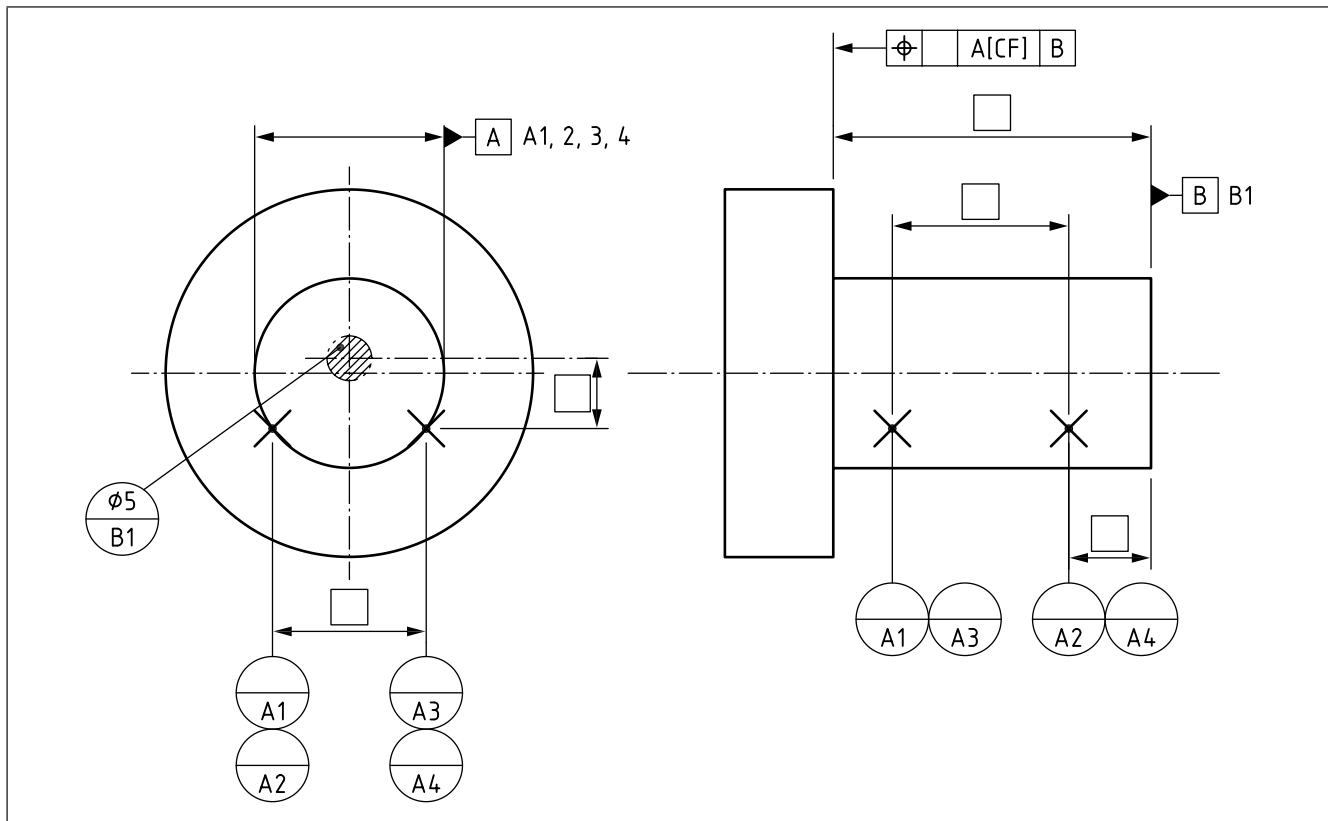
Figure 112 Simplification of drawing indication when there is only one datum target area



### 6.8.7 Datums based on more than one datum target

If a single datum is based on more than one datum target, the relationships between the datum targets shall as necessary be defined with theoretically exact dimensions (see Figure 113).

Figure 113 Datums based on more than one datum target



**NOTE 1** In this case the TEDs can be used without any corresponding geometrical tolerance. The tolerance on the location of the datum targets is not part of the definition of the workpiece geometry, so does not need to be defined on the design specification.

When datum targets are used to define datums on a rigid workpiece (see Figure 114 and Figure 115), the primary datum shall normally be defined with three datum targets, the secondary datum with two datum targets, and the tertiary datum with one datum target, except where the geometry of the datum feature necessitates the use of more datum targets in order to ensure a unique solution (see Figure 113).

If a primary datum plane is defined with more than three datum targets, ISO standards do not currently define how this would be interpreted. In such a case, a statement shall be included in the TPS to explain how the datum is to be constructed, e.g.:

DATUM A IS A LEAST SQUARES PLANE CONSTRUCTED FROM DATUM TARGETS A1-8.

**NOTE 2** This requirement also applies when a secondary datum plane is based on more than two datum targets, and a tertiary datum plane is based on more than one datum target.



Figure 114 Application of datum targets

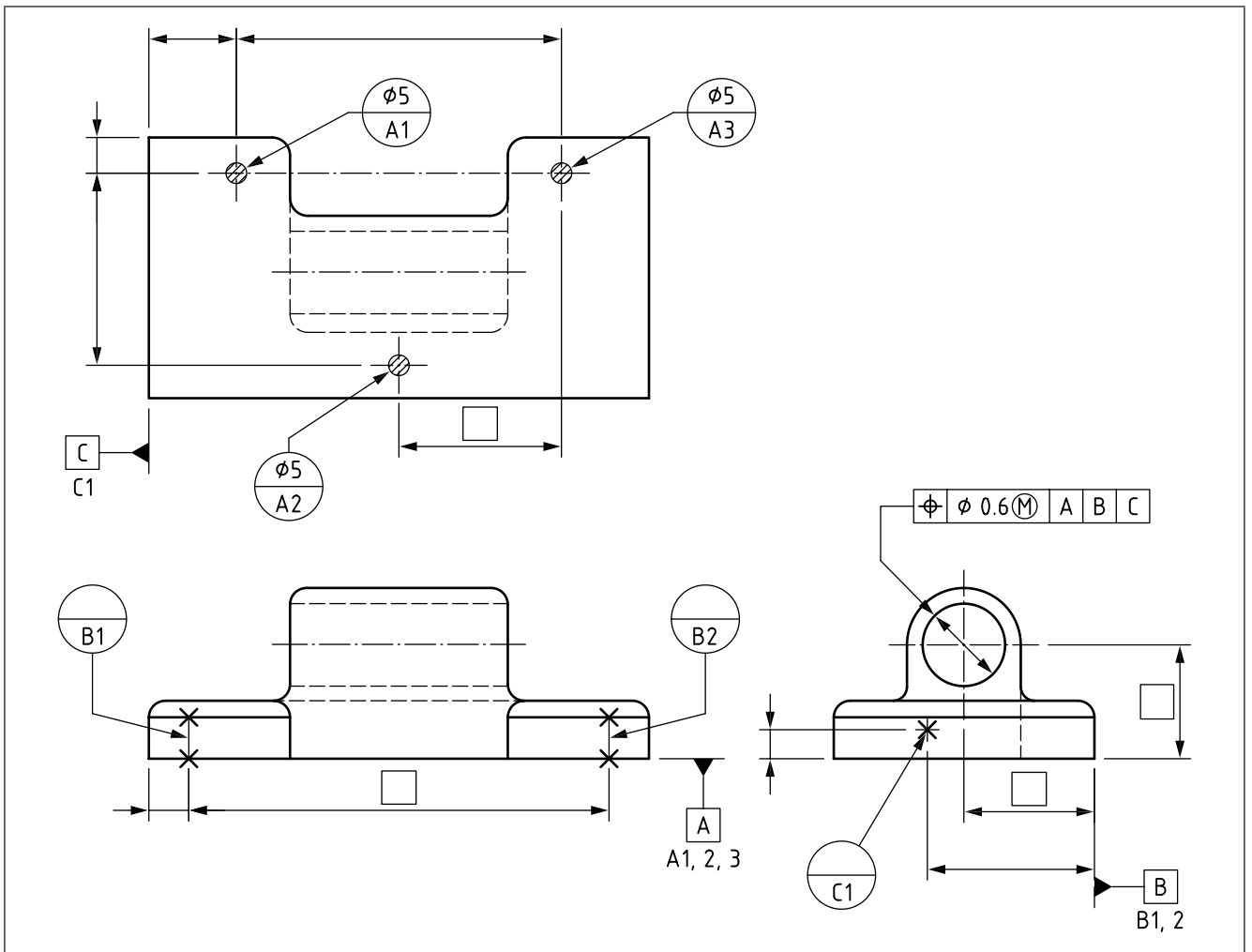
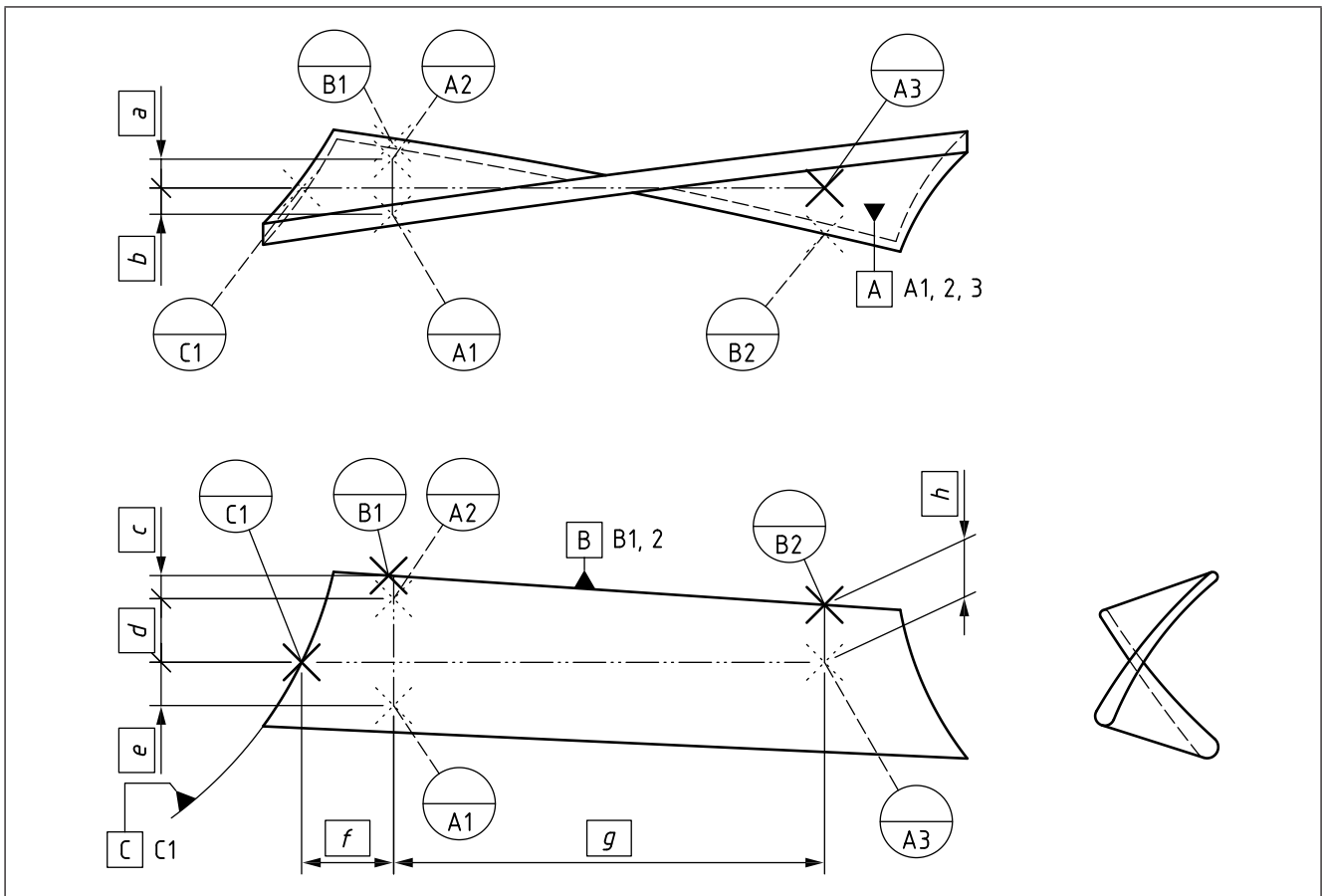


Figure 115 Application of datum targets

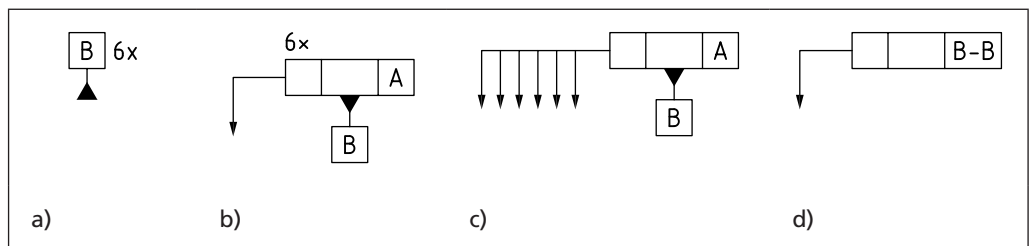


**6.8.8 Datums based on multiple datum features or targets**

Where multiple datum features or targets are to be used to define a specific situation feature of a datum, this shall be shown in accordance with Figure 116.

*NOTE* Where multiple individual datum features are used to define a single datum, simplification can be used. See Figure 116.

Figure 116 Examples of complementary indication



## 6.9 Modifying the effects of datums

### COMMENTARY ON 6.9

The effect of a datum can be modified in several ways.

### 6.9.1 "Orientation only" modifier

#### COMMENTARY ON 6.9.1

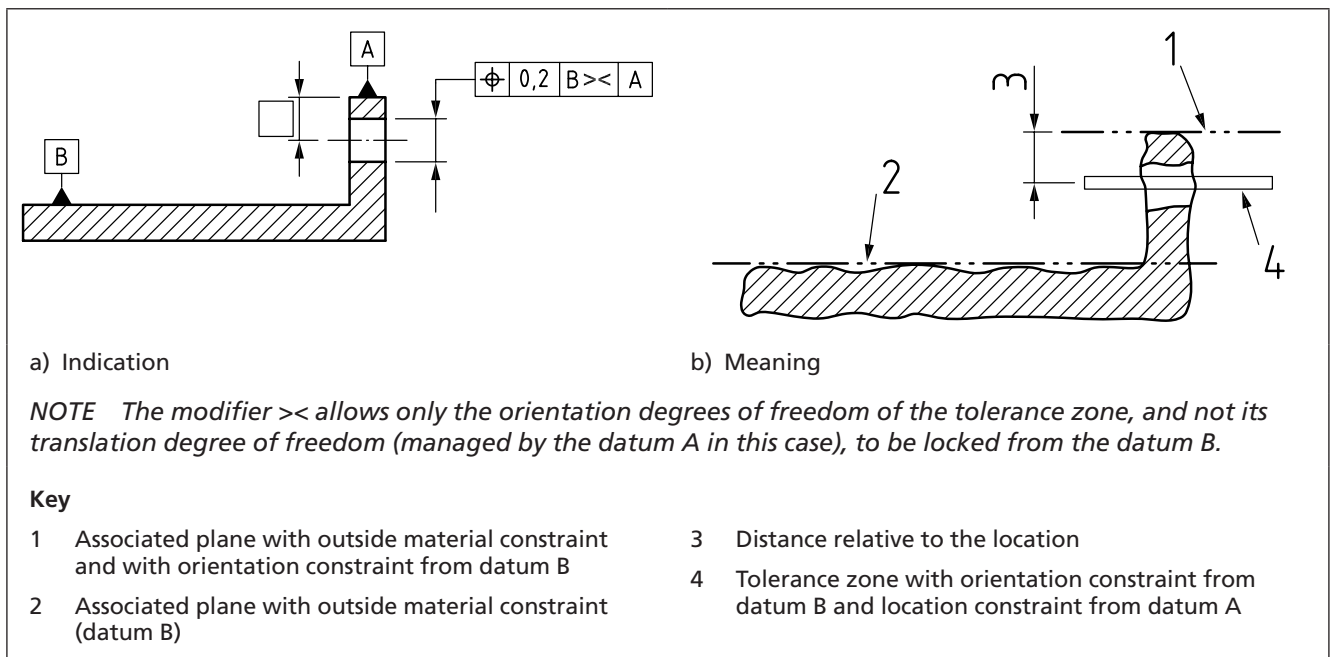
In some instances, a datum might be required only to control the orientation of a tolerance zone, and not its location.

In order to prevent the datum controlling the location of the tolerance zone, the "orientation only" modifier shall be used in the datum reference compartment of the tolerance frame (see Figure 117).

The "orientation only" modifier shall consist of two angle brackets used in the following arrangement, "><".

If the datum reference can only control the orientation of the tolerance zone in any case, the "><" modifier is redundant and shall be omitted.

Figure 117 Application of "orientation-only" modifier



### 6.9.2 Situation feature modifiers

#### COMMENTARY ON 6.9.2

A datum can be based on a set of more than one situation feature. In some instances, the full effect of all the situation features defining the datum can prevent the tolerance requirement from being correctly defined. The tolerance requirement might need to utilize the effect of only a subset of the situation features.

Individual situation features shall be invoked, as appropriate, by using the following modifiers (see Figure 118).

- If the situation feature to be utilized is a plane, the [PL] modifier shall be used.
- If the situation feature to be utilized is a straight line, the [SL] modifier shall be used.
- If the situation feature to be utilized is a point, the [PT] modifier shall be used.

**NOTE** More than one of these modifiers can be used with a single datum reference.

Figure 118 Indication of which modifier is needed in the set of situation features

	$\overline{\text{B[PL]}}$		$\overline{\text{B[SL]}}$
a) The plane		b) The straight line	
	$\overline{\text{B[PT]}}$		$\overline{\text{B[PL][SL]}}$
c) The point		d) The plane and the straight line	

# Section 7: Geometrical product specification – Tolerances

## 7.1 Geometric tolerances

Geometrical tolerancing shall conform to the following standards, as appropriate.

BS EN ISO 1101	<i>Geometrical product specifications (GPS) – Geometrical tolerancing – Tolerances of form, orientation, location and run-out</i>
BS EN ISO 2692	<i>Geometrical product specifications (GPS) – Geometrical tolerancing – Maximum material requirement (MMR), least material requirement (LMR) and reciprocity requirement (RPR)</i>
BS EN ISO 5458	<i>Geometrical Product Specifications (GPS) – Geometrical tolerancing – Positional tolerancing</i>
BS EN ISO 5459	<i>Geometrical product specifications (GPS) – Geometrical tolerancing – Datums and datum systems</i>
BS EN ISO 7083	<i>Technical drawings – Symbols for geometrical tolerancing – Proportions and dimensions</i>
BS EN ISO 12180-1	<i>Geometrical product specifications (GPS) – Cylindricity – Part 1: Vocabulary and parameters of cylindrical form</i>
BS EN ISO 12180-2	<i>Geometrical product specifications (GPS) – Cylindricity – Part 2: Specification operators</i>
BS EN ISO 12181-1	<i>Geometrical product specifications (GPS) – Roundness – Part 1: Vocabulary and parameters of roundness</i>
BS EN ISO 12181-2	<i>Geometrical product specifications (GPS) – Roundness – Part 2: Specification operators</i>
BS EN ISO 12780-1	<i>Geometrical product specifications (GPS) – Straightness – Part 1: Vocabulary and parameters of straightness</i>
BS EN ISO 12780-2	<i>Geometrical product specifications (GPS) – Straightness – Part 2: Specification operators</i>
BS EN ISO 12781-1	<i>Geometrical product specifications (GPS) – Flatness – Part 1: Vocabulary and parameters of flatness</i>
BS EN ISO 12781-2	<i>Geometrical product specifications (GPS) – Flatness – Part 2: Specification operators</i>

## 7.2 Basic concepts

Geometrical tolerances shall be specified in accordance with functional requirements.

*NOTE 1 Manufacturing and inspection requirements can also influence geometrical tolerancing.*

*NOTE 2 Indicating geometrical tolerances on a drawing does not necessarily imply the use of any particular method of production, measurement or gauging.*

Tolerances shall never be implied, and shall always be indicated.

A geometrical tolerance applied to a feature defines the tolerance zone within which that feature shall be contained (see 7.6).

*NOTE 3* A feature is a specific portion of the workpiece, such as a point, a line or a surface; these features can be integral features (e.g. the external surface of a cylinder) or derived (e.g. a median line or median surface). See BS EN ISO 14660-1.

The tolerance shall apply to the whole extent of the considered feature, unless otherwise specified as in 7.9 and 7.10.

*NOTE 4* Geometrical tolerances which are assigned to features related to a datum do not limit the form deviations of the datum feature itself. It might be necessary to specify tolerances of form for the datum feature(s).

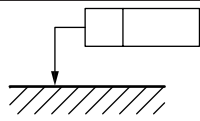
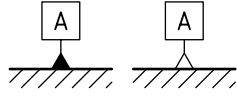






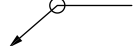

## 7.3 Symbols

Symbols for geometrical characteristics shall be as indicated in Table 17 and Table 18, and as indicated in BS EN ISO 1101.

Table 17 Symbols for geometrical characteristics

Tolerances	Characteristics	Symbol	Datum needed
Form	Straightness	—	no
	Flatness	▭	no
	Roundness	○	no
	Cylindricity	⊘	no
	Profile any line	∩	no
	Profile any surface	∪	no
Orientation	Parallelism	//	yes
	Perpendicularity	⊥	yes
	Angularity	∠	yes
	Profile any line	∩	yes
	Profile any surface	∪	yes
Location	Position	⊕	yes or no
	Concentricity (for centre points)	⊙	yes
	Coaxiality (for axes)	⊗	yes
	Symmetry	≡	yes
	Profile any line	∩	yes
	Profile any surface	∪	yes
Run-out	Circular run-out	↗	yes
	Total run-out	↗↗	yes

Table 18 Additional symbols

Description	Symbol
Toleranced feature indication	
Datum feature indication	
Datum target indication	
Theoretically exact dimensions	
Projected tolerance zone	
Maximum material requirement	
Least material requirement	
Free state condition (non-rigid parts)	
All around (profile)	
Envelope requirement	
Common zone	CZ
Minor diameter	LD
Major diameter	MD
Pitch diameter	PD
Line element	LE
Not convex	NC
Any cross section	ACS

*NOTE Further symbols and modifiers are standardized in BS EN ISO 1101 and other standards.*

## 7.4 Tolerance frame

The requirements shall be shown in a rectangular frame which is divided into two or more compartments, in accordance with BS EN ISO 1101. These compartments shall contain, from left to right, in the following order:

- the symbol for the geometrical characteristic;
- the tolerance value in the unit used for linear dimensions, preceded by the symbol "Ø" if the tolerance zone is circular or cylindrical or by "SØ" if the tolerance zone is spherical;
- if applicable, the letter or letters identifying the datum or common datum or datum system.

When a tolerance applies to more than one feature this shall be indicated above the tolerance frame by the number of features, followed by the symbol "x" (see Figure 119).

If required, indications qualifying the form of the feature within the tolerance zone shall be written near the tolerance frame (see example of Figure 120).

*NOTE 1* If it is necessary to specify more than one geometrical characteristic for a feature, the requirements can be given in tolerance frames, one under the other for convenience (see example of Figure 121).

*NOTE 2* Figure 132 gives examples of geometrical tolerances and requirements associated with them.

Figure 119 Tolerance applying to more than one feature

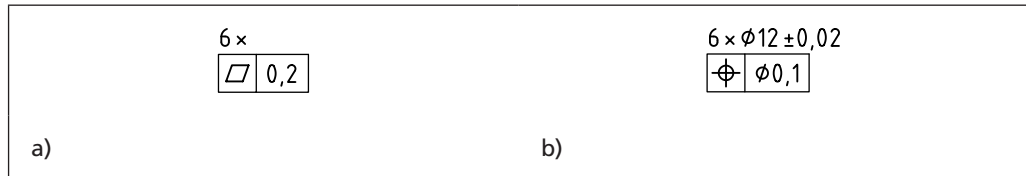


Figure 120 Indications qualifying the form of the feature within the tolerance zone

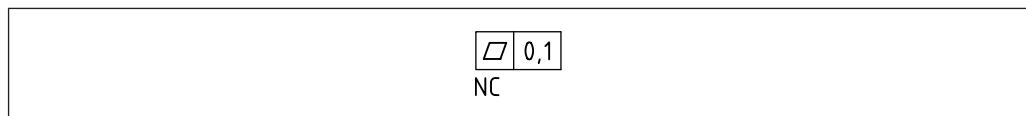
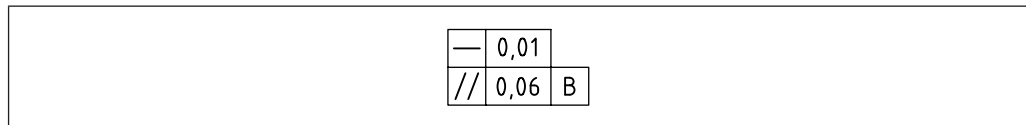


Figure 121 Requirements given in tolerance frames one under the other



## 7.5 Toleranced features

As specified by BS EN ISO 1101, the tolerance frame shall be connected to the toleranced feature by a leader line starting from either side of the frame and ending with a terminator (arrowhead or filled dot) in one of the following ways:

- on the outline of the feature or an extension of the outline (but clearly separated from the dimension line), with a leader line terminating in an arrowhead, when the tolerance refers to the line or surface itself [see Figure 122a) and Figure 122b)];
- NOTE 1* The arrowhead could be placed on a reference line using a leader line to point to the surface [see example of Figure 122c)].
- on the surface of a feature, with a leader line ending in a filled dot on the surface, when the tolerance refers to that surface [see Figure 122d)];
  - as an extension of the dimension line when the tolerance refers to the median line or median surface, or a point defined by the feature so dimensioned [see Figure 123)].

If needed, an indication specifying the form of the feature (line instead of a surface) shall be written near the tolerance frame.

*NOTE 2* When the toleranced feature is a line, a further indication might be needed to control the orientation.



Figure 122 Terminator on the outline or the surface of a feature or as an extension

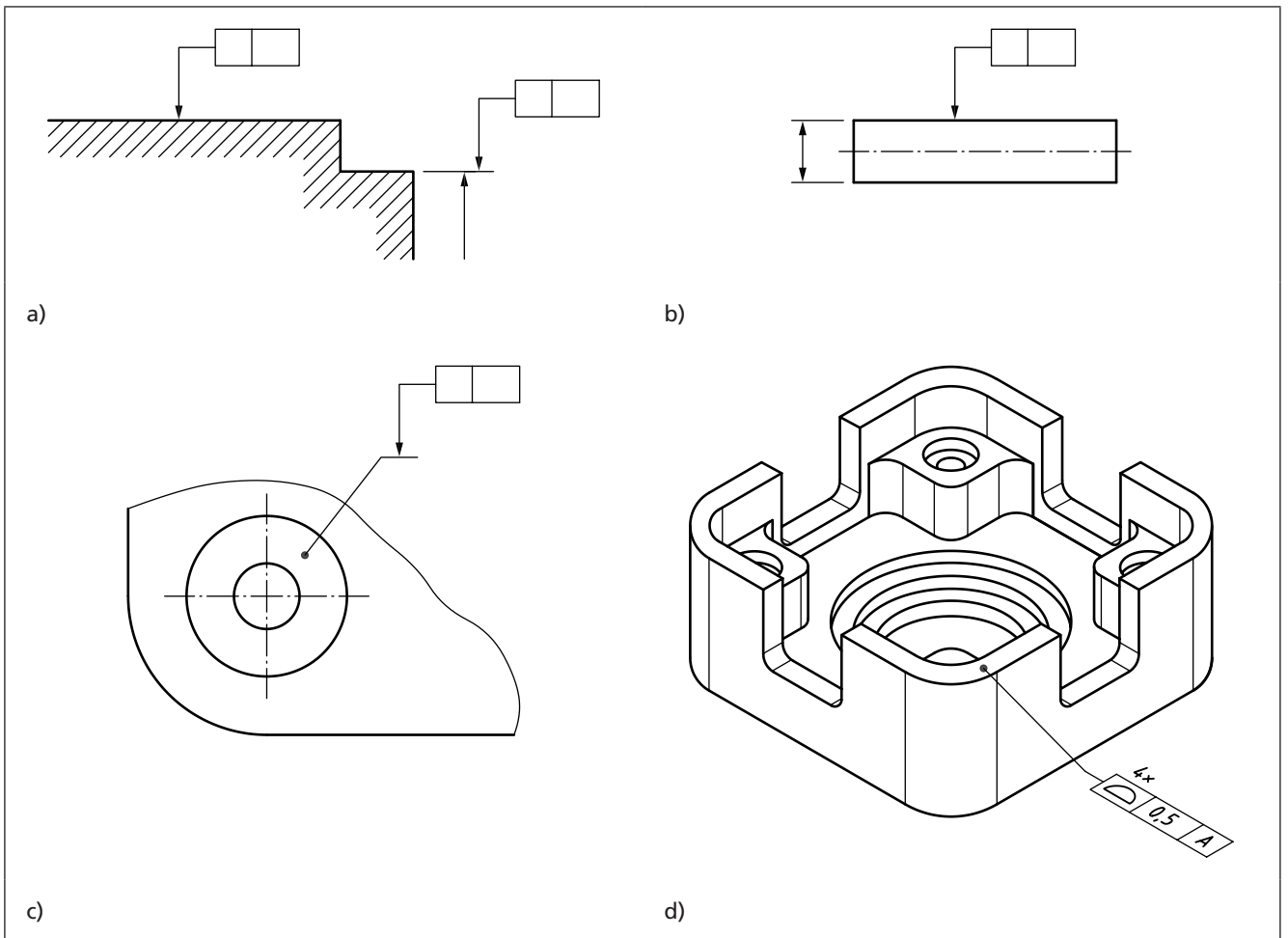
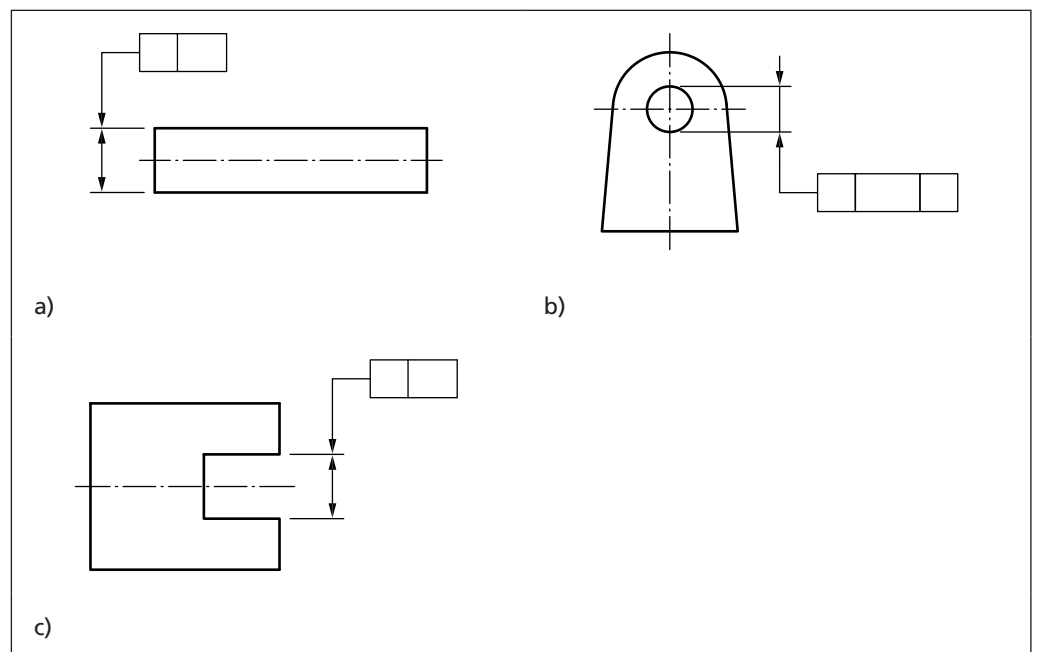


Figure 123 Terminator as an extension of the dimension line



## 7.6 Tolerance zones

The width of the tolerance zone shall apply normal to the specified geometry (see Figure 124), unless otherwise indicated (see Figure 125).

*NOTE 1 The orientation alone of the leader line does not influence the definition of the tolerance.*

According to the characteristic to be tolerated and the manner in which it is dimensioned, the tolerance zone shall be one of the following:

- the space within a circle;
- the space between two concentric circles;
- the space between two equidistant lines or two parallel straight lines;
- the space within a cylinder;
- the space between two coaxial cylinders;
- the space between two equidistant surfaces or two parallel planes;
- the space within a sphere.

Unless a more restrictive indication is required, for example by an explanatory note, the tolerated feature shall be of any form or orientation within this tolerance zone.

Figure 124 Width of tolerance zone applying to the specified geometry

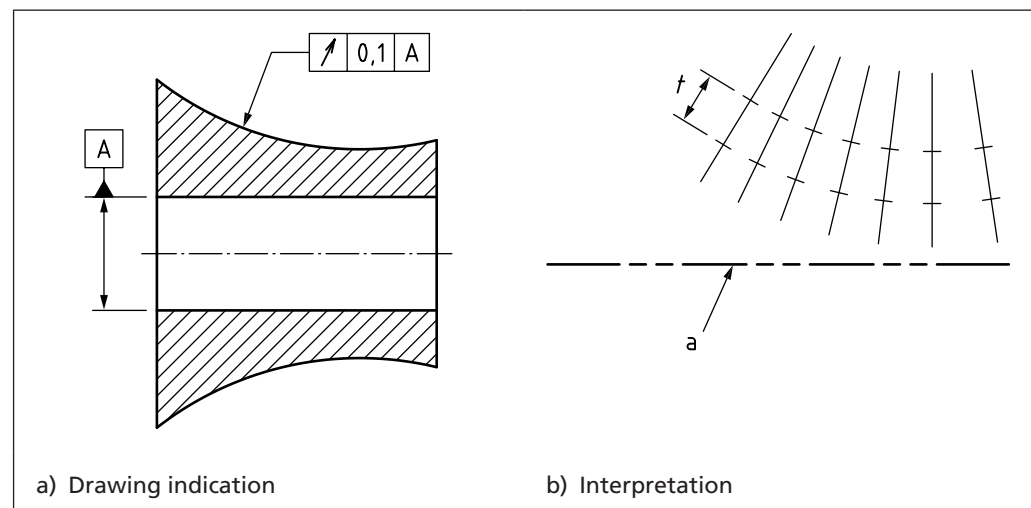
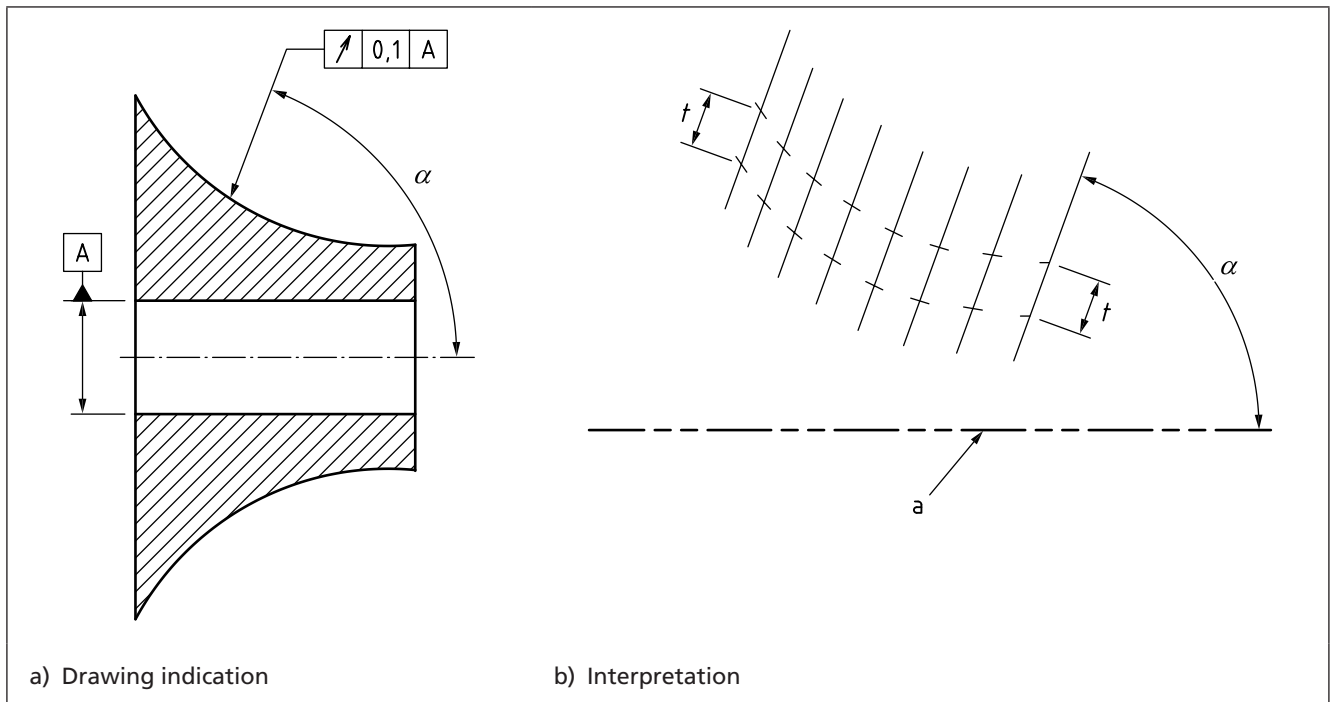


Figure 125 Width of tolerance zone, otherwise indicated



The angle  $\alpha$  shown in Figure 125a) shall be indicated, even if it is equal to  $90^\circ$ .

In the case of roundness, the width of the tolerance zone shall always apply in a plane perpendicular to the nominal axis.

In the case of a centre point or median line or median surface tolerated in one direction:

- the orientation of the width of a positional tolerance zone shall be based on the pattern of the theoretically exact dimensions (TED) and shall be at  $0^\circ$  or  $90^\circ$  as indicated by the direction of the arrowhead of the leader line, unless otherwise indicated (see Figure 126);
- the orientation of the width of an orientation tolerance zone shall be at  $0^\circ$  or  $90^\circ$  relative to the datum as indicated by the direction of the arrowhead of the leader line, unless otherwise indicated (see Figure 127 and Figure 128);
- when two tolerances are stated, they shall be perpendicular to each other, unless otherwise specified (see Figure 127 and Figure 128).

Figure 126 Orientation of the width of a positional tolerance zone

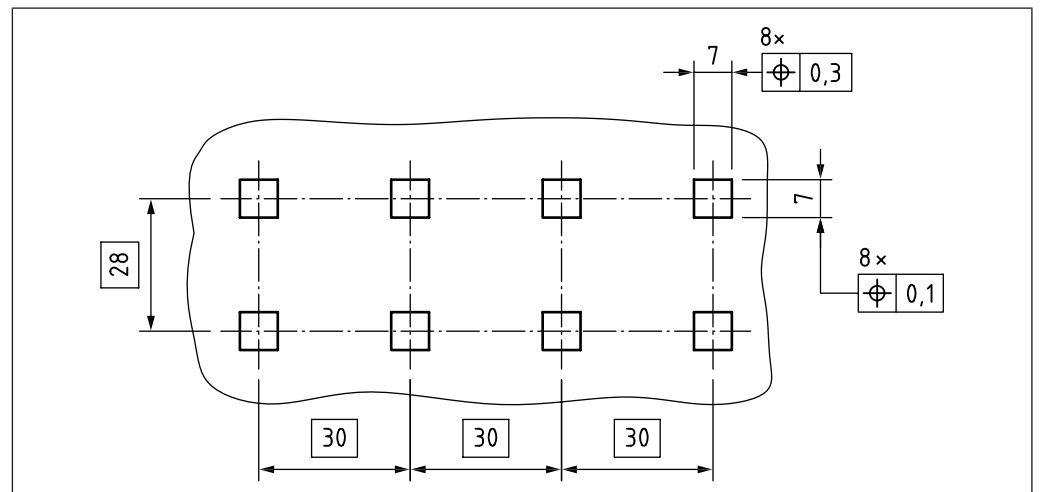


Figure 127 Orientation of the width of an orientation tolerance zone

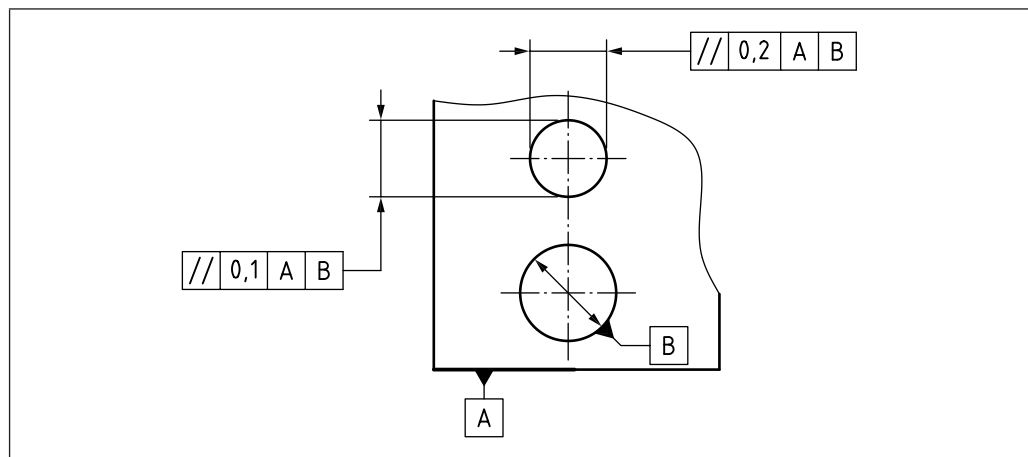
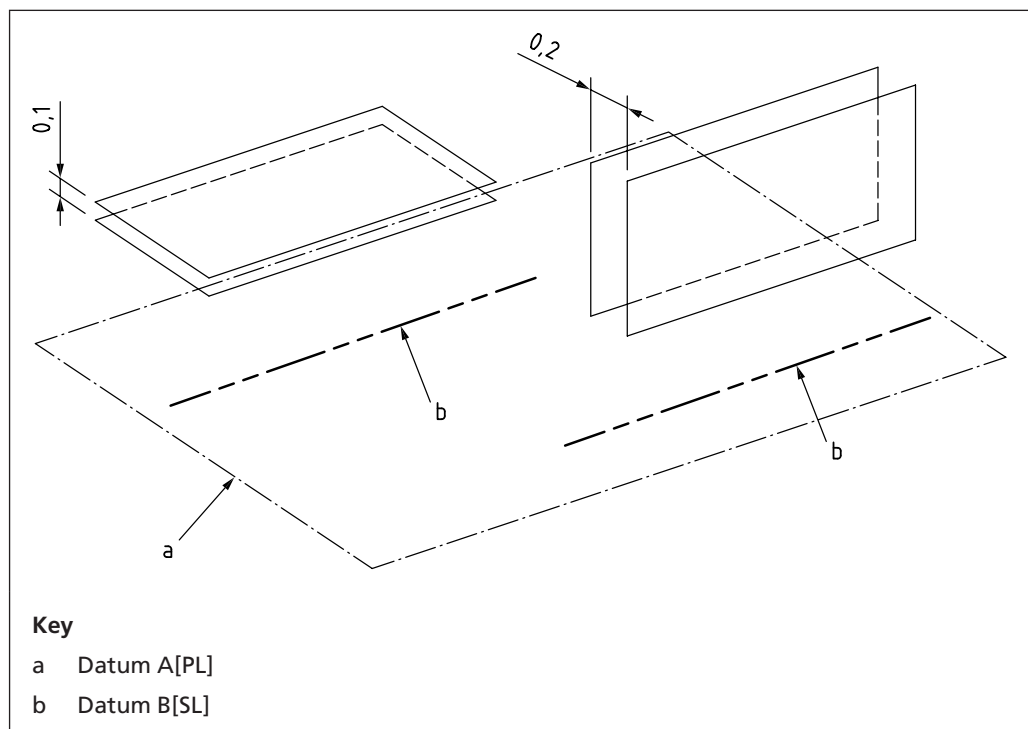
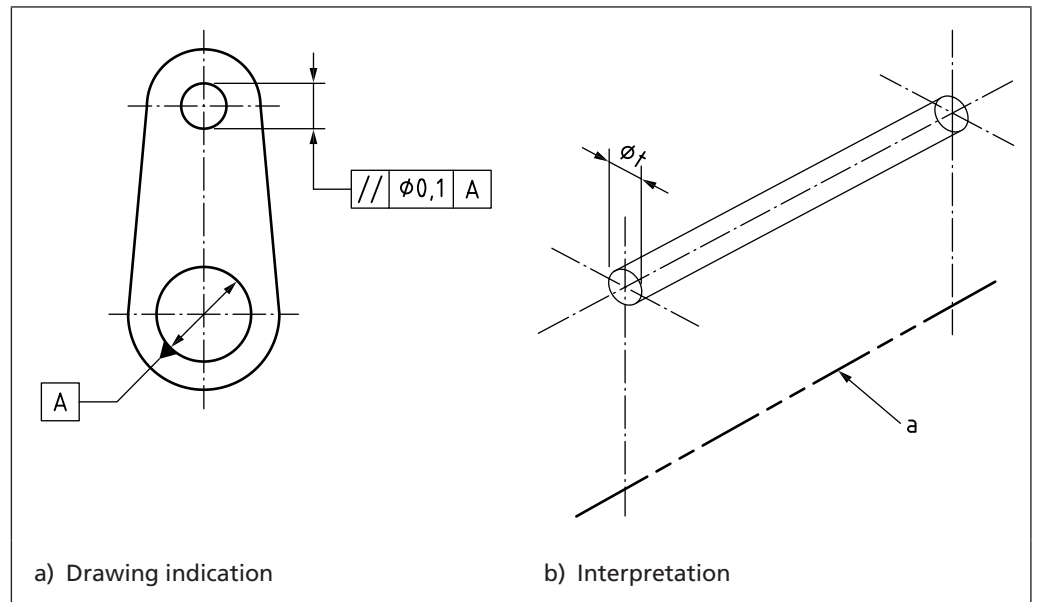


Figure 128 Tolerances perpendicular to each other



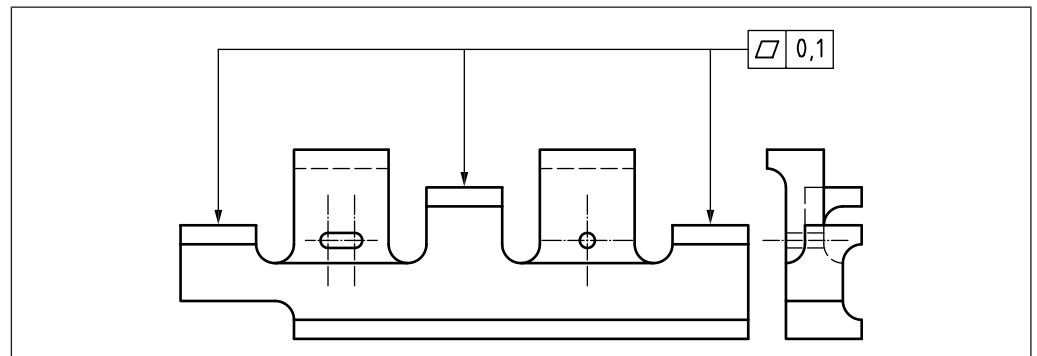
The tolerance zone shall be cylindrical (see Figure 129) or circular if the tolerance value is preceded by the symbol "Ø", or spherical if it is preceded by the symbol "SØ".

Figure 129 Cylindrical and circular tolerance zones



**NOTE 2** Individual tolerance zones of the same value applied to several separate features can be specified (see Figure 130).

Figure 130 Tolerance zones applied to separate features

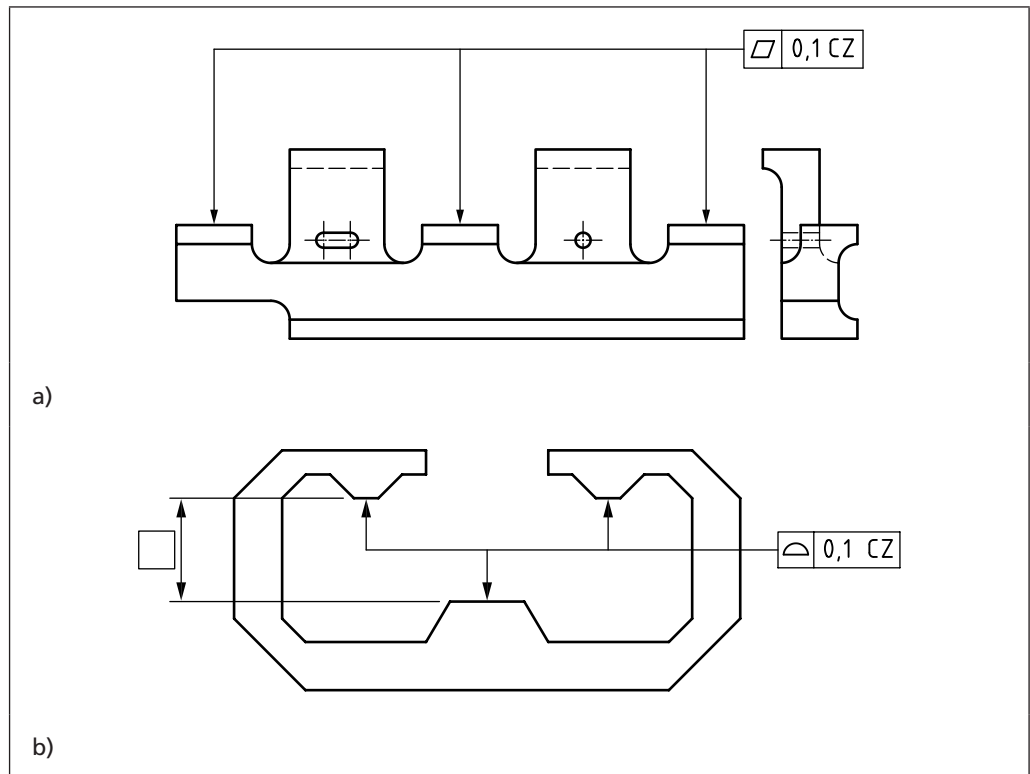


Where a common tolerance zone is applied to several separate features, this common requirement shall be indicated by the symbol "CZ" for common zone following the tolerance in the tolerance frame [see the example in Figure 131a)].

Where several tolerance zones (controlled by the same tolerance frame) are applied simultaneously to several separate features (not independently) to create a combined zone, the requirement shall be indicated by the symbol "CZ" for common zone following the tolerance in the tolerance frame [see the example in Figure 131b)] and an indication that the specification applies to several features, e.g. using "3×" over the tolerance frame or using three leader lines attached to the tolerance frame.

Where CZ is indicated in the tolerance frame, all the related individual tolerance zones shall be constrained in location and in orientation amongst themselves using either implicit (0 mm, 0°, 90°, etc.) or TEDs.

Figure 131 Single tolerance zone applied to separate features



NOTE 3 Figure 132 gives examples of geometrical tolerances and requirements associated with them.

Figure 132 Examples of geometrical tolerancing (1 of 6)

Symbol	Definition of the tolerance zone	Indication and explanation in 2D
<b>Straightness tolerance</b>		
—	The tolerance zone, in the considered plane, shall be limited by two parallel straight lines a distance $t$ apart and in the specified direction only ( $a$ = any distance).	Any extracted (actual) line on the upper surface, parallel to the plane of projection in which the indication is shown, shall be contained between two parallel straight lines 0,1 apart.
—	The tolerance zone shall be limited by two parallel planes a distance $t$ apart.	Any extracted (actual) generating line on the cylindrical surface shall be contained between two parallel planes 0,1 apart.

Figure 132 Examples of geometrical tolerancing (2 of 6)

Symbol	Definition of the tolerance zone	Indication and explanation in 2D
—	The tolerance zone shall be limited by a cylinder of diameter $t$ , if the tolerance value is preceded by the symbol $\varnothing$ .	The extracted (actual) median line of the cylinder to which the tolerance applies shall be contained within a cylindrical zone of diameter 0,08.
<b>Flatness tolerance</b>		
▭	The tolerance zone shall be limited by two parallel planes a distance $t$ apart.	The extracted (actual) surface shall be contained between two parallel planes 0,08 apart.
<b>Roundness tolerance</b>		
○	The tolerance zone, in the considered cross section, shall be limited by two concentric circles with a difference in radii of $t$ ( $a$ = any cross section).	The extracted (actual) circumferential line in any cross section of the conical surface shall be contained between two coplanar concentric circles with a difference in radii of 0,1.

Figure 132 Examples of geometrical tolerancing (3 of 6)

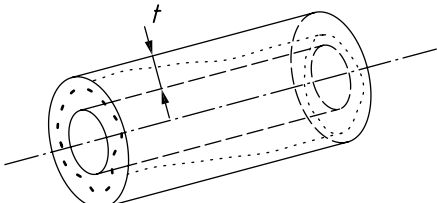
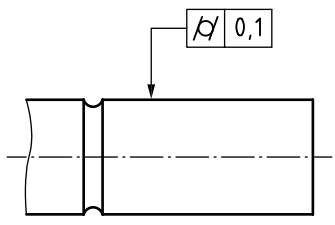
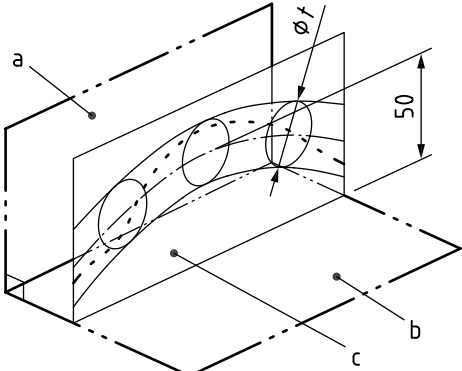
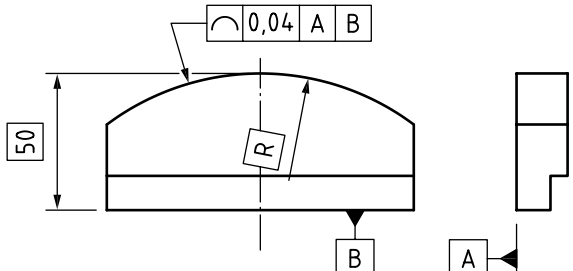
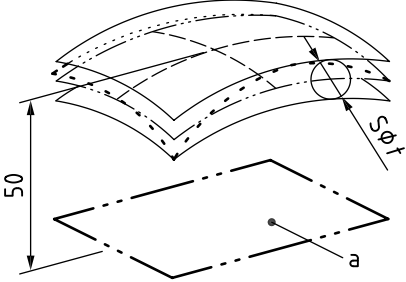
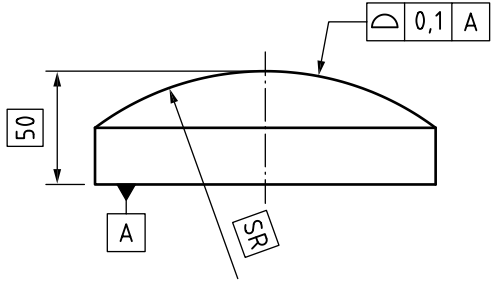
Symbol	Definition of the tolerance zone	Indication and explanation in 2D
<b>Cylindricity tolerance</b>		
$\text{⌀}$	The tolerance zone shall be limited by two coaxial cylinders with a difference in radii of $t$ .	The extracted (actual) cylindrical surface shall be contained between two coaxial cylinders with a difference in radii of 0,1.
		
<b>Profile tolerance of a line related to a datum system</b>		
$\text{⌒}$	The tolerance zone shall be limited by two lines enveloping circles of diameter $t$ , the centres of which are situated on a line having the theoretically exact geometrical form with respect to datum plane A and datum plane B.	In each section, parallel to the plane of projection in which the indication is shown, the extracted (actual) profile line shall be contained between two equidistant lines enveloping circles of diameter 0,04, the centres of which are situated on a line having the theoretically exact geometrical form with respect to datum plane A and datum plane B.
		
	<i>NOTE a = datum A; b = datum B; c = plane parallel to datum A.</i>	
<b>Profile tolerance of a surface related to a datum</b>		
$\text{Ⓢ}$	The tolerance zone shall be limited by two surfaces enveloping spheres of diameter $t$ , the centres of which are situated on a surface having the theoretically exact geometrical form with respect to datum plane A (a = datum A).	The extracted (actual) surface shall be contained between two equidistant surfaces enveloping spheres of diameter 0,1, the centres of which are situated on a surface having the theoretically exact geometrical form with respect to datum plane A.
		



Figure 132 Examples of geometrical tolerancing (4 of 6)

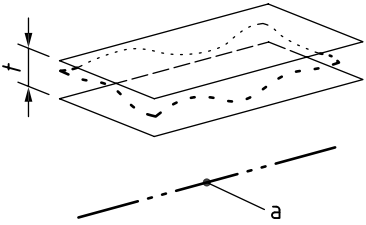
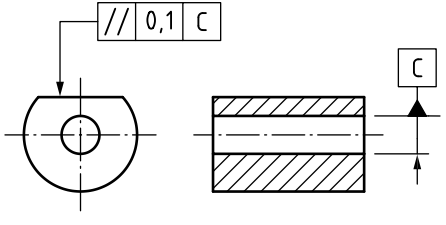
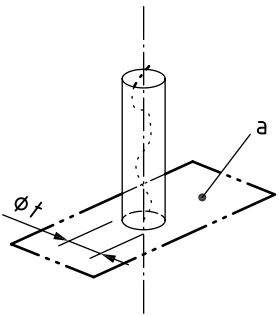
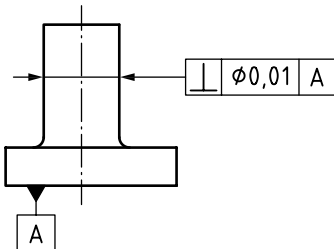
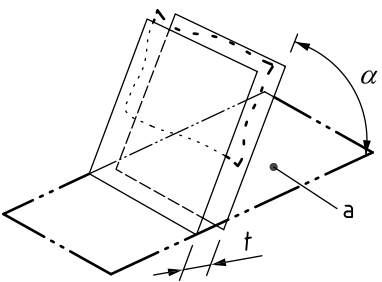
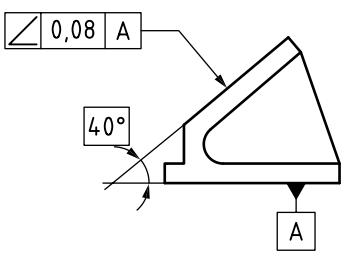
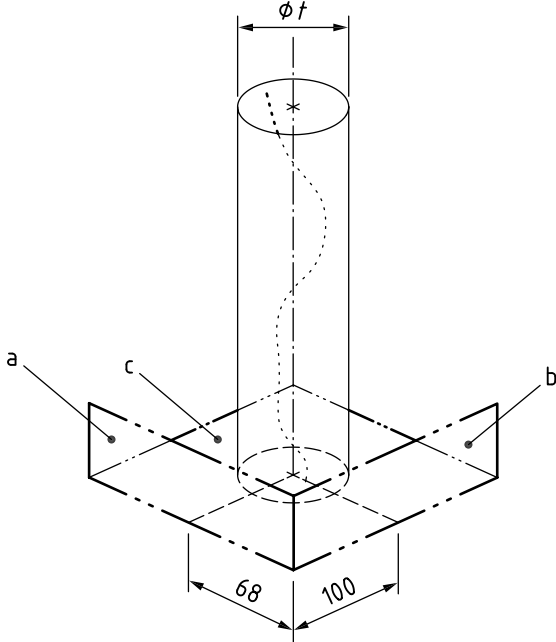
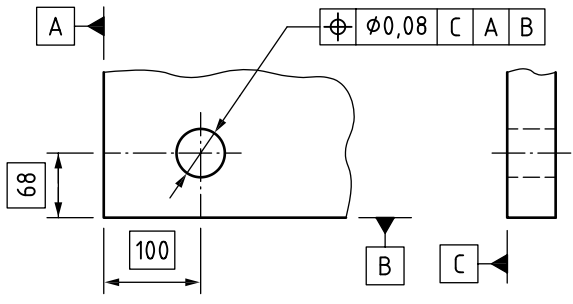
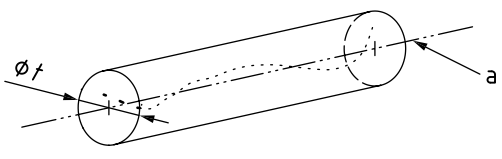
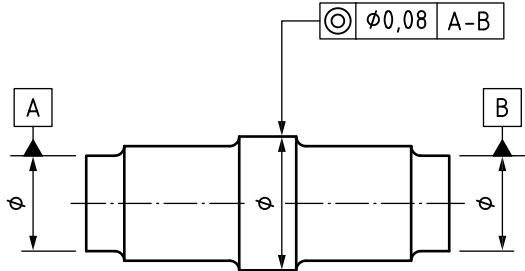
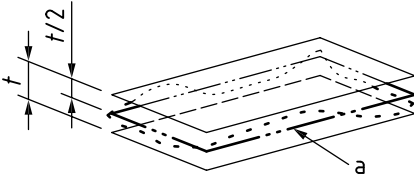
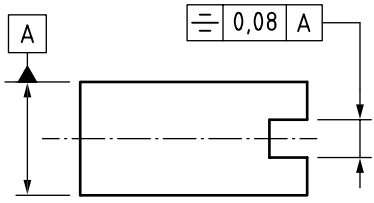
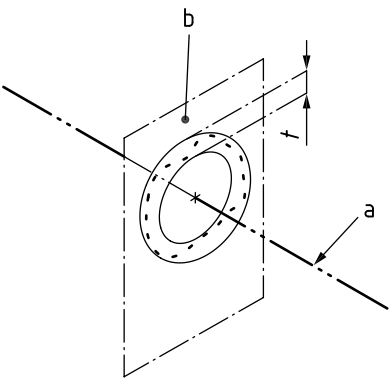
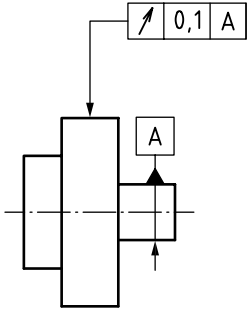
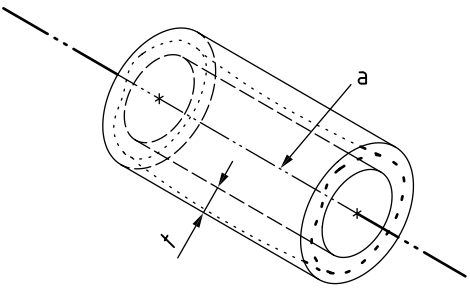
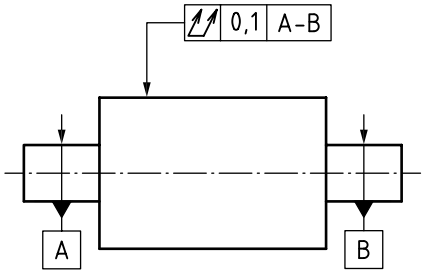
Symbol	Definition of the tolerance zone	Indication and explanation in 2D
<b>Parallelism tolerance of a surface related to a datum line</b>		
//	The tolerance zone shall be limited by two parallel planes a distance $t$ apart and parallel to the datum ( $a = \text{datum C}$ ).	The extracted (actual) surface shall be contained between two parallel planes 0,1 apart, which are parallel to the datum axis C.
		
<b>Perpendicularity tolerance of a line related to a datum surface</b>		
⊥	The tolerance zone shall be limited by a cylinder of diameter $t$ perpendicular to the datum if the tolerance value is preceded by the symbol $\varnothing$ ( $a = \text{datum A}$ ).	The extracted (actual) median line of the cylinder shall be within a cylindrical zone of diameter 0,01 perpendicular to datum plane A.
		
<b>Angularity tolerance of a surface related to a datum surface</b>		
∠	The tolerance zone shall be limited by two parallel planes a distance $t$ apart and inclined at the specified angle to the datum ( $a = \text{datum A}$ ).	The extracted (actual) surface shall be contained between two parallel planes 0,08 apart that are inclined at a theoretically exact angle of $40^\circ$ to datum plane A.
		

Figure 132 Examples of geometrical tolerancing (5 of 6)

Symbol	Definition of the tolerance zone	Indication and explanation in 2D
<b>Positional tolerance of a line</b>		
⊕	The tolerance zone shall be limited by a cylinder of diameter $t$ if the tolerance value $s$ is preceded by the symbol $\emptyset$ . The axis of the tolerance cylinder shall be fixed by theoretically exact dimensions with respect to the datums C, A and B.	<p>The extracted (actual) median line shall be within a cylindrical zone of diameter 0,08, the axis of which coincides with the theoretically exact position of the considered hole, with respect to datum planes C, A and B.</p>  
<b>Coaxiality tolerance of an axis</b>		
◎	The tolerance zone shall be limited by a cylinder of diameter $t$ ; the tolerance value shall be preceded by the symbol $\emptyset$ . The axis of the cylindrical tolerance zone coincides with the datum (a = datum A-B).	<p>The extracted (actual) median line of the tolerated cylinder shall be within a cylindrical zone of diameter 0,08, the axis of which is the common datum straight line A-B.</p>  

NOTE a = datum A; b = datum B; c = datum C.

Figure 132 Examples of geometrical tolerancing (6 of 6)

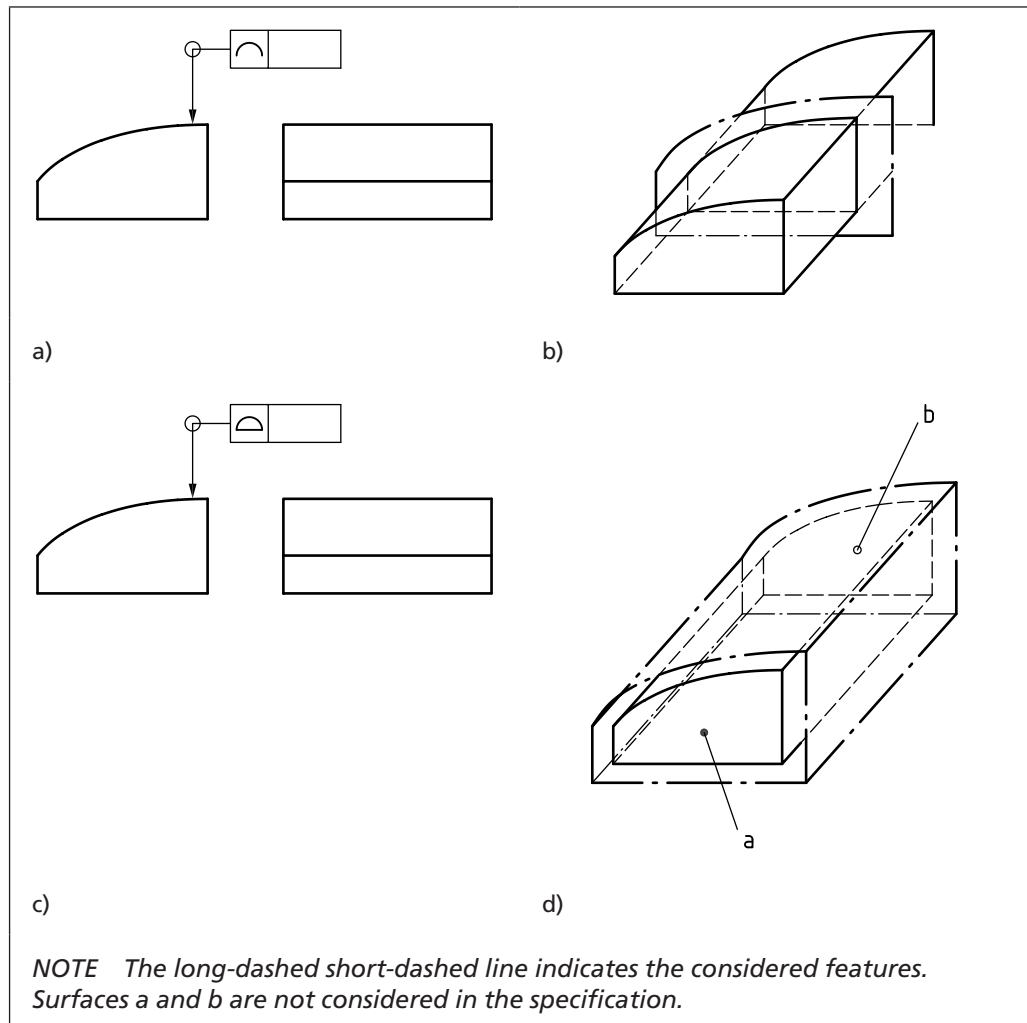
Symbol	Definition of the tolerance zone	Indication and explanation in 2D
<b>Symmetry tolerance of a median plane</b>		
≡	<p>The tolerance zone shall be limited by two parallel planes a distance <math>t</math> apart, symmetrically disposed about the median plane, with respect to the datum (<math>a = \text{datum}</math>).</p> 	<p>The extracted (actual) median surface shall be contained between two parallel planes 0,08 apart, which are symmetrically disposed about the datum median plane A.</p>  <p>The extracted (actual) median surface shall be contained between two parallel planes 0,08 apart and symmetrically disposed about the common datum plane A-B.</p>
<b>Circular run-out tolerance – Radial</b>		
↗	<p>The tolerance zone shall be limited within any cross section perpendicular to the datum axis by two concentric circles with a difference in radii of <math>t</math>, the centres of which coincide with the datum.</p> 	<p>The extracted (actual) line in any cross section plane perpendicular to datum axis A shall be contained between two coplanar concentric circles with a difference in radii of 0,1.</p> 
<i>NOTE a = datum; b = cross section plane.</i>		
<b>Total radial run-out tolerance</b>		
↗↗	<p>The tolerance zone shall be limited by two coaxial cylinders with a difference in radii of <math>t</math>, the axes of which coincide with the datum (<math>a = \text{datum A-B}</math>).</p> 	<p>The extracted (actual) surface shall be contained between two coaxial cylinders with a difference in radii of 0,1 and the axes coincident with the common datum straight line A-B.</p> 

## 7.7 Supplementary indications

If a profile characteristic is applied to the entire outline of the cross sections or, if it is applied to the entire surface represented by the outline, it shall be indicated using the symbol “all around”.

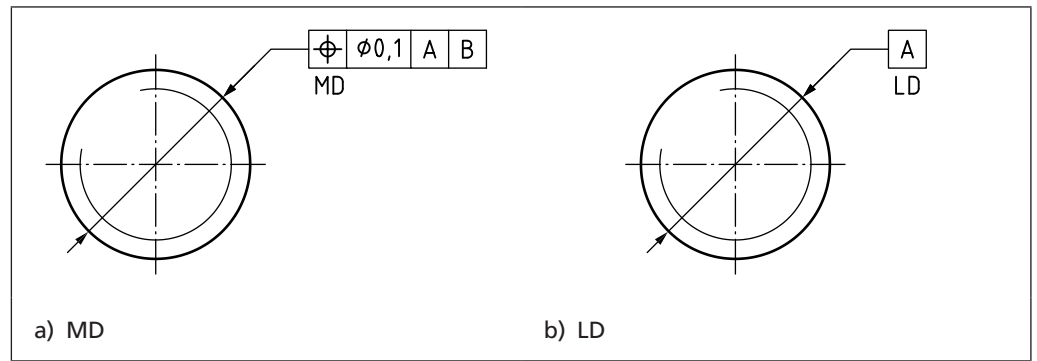
*NOTE* The “all around” symbol does not involve the entire workpiece, but only the surfaces represented by the outline and identified by the tolerance indication (see Figure 133).

Figure 133 Examples of the use of the “all around” symbol



Tolerances and datums specified for screw threads shall apply to the axis derived from the pitch cylinder, unless otherwise specified, e.g. “MD” for major diameter and “LD” for minor diameter (see example of Figure 134). Tolerances and datums specified for gears and splines shall designate the specific feature to which they apply, i.e. “PD” for pitch diameter, “MD” for major diameter or “LD” for minor diameter.

Figure 134 Examples of "MD" and "LD"



### 7.8 Theoretically exact dimensions (TED)

*COMMENTARY ON 7.8*

A TED is a dimension which has the dimension value enclosed in a frame.

No tolerance shall be applied directly to the value of a TED.

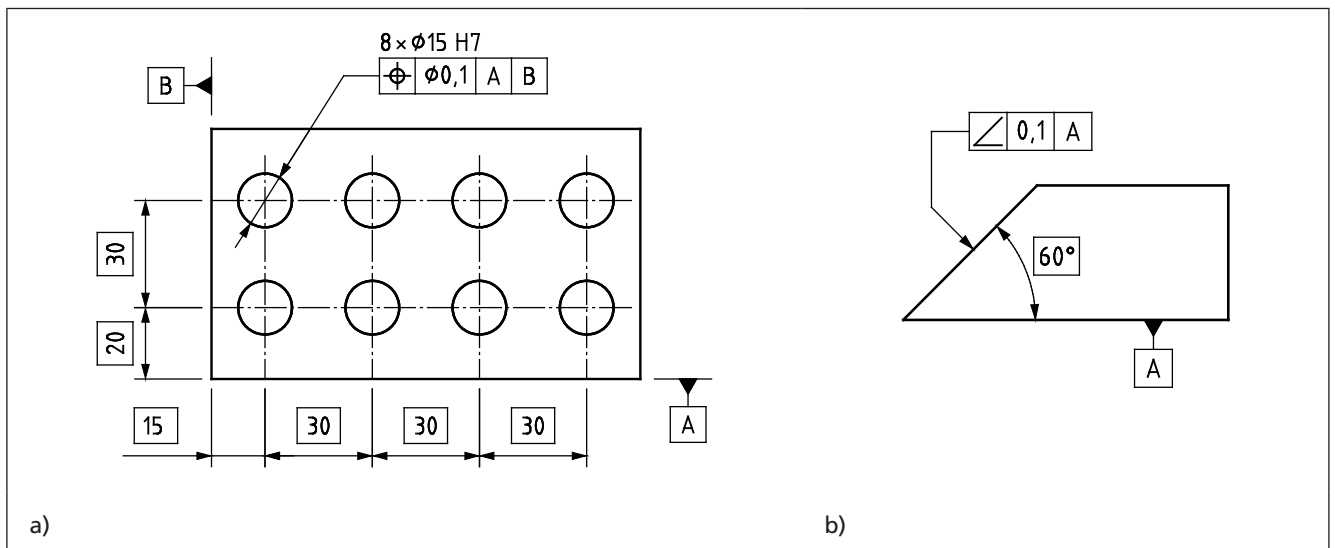
When a geometrical tolerance is used to tolerance the location of a feature (or group of features), the theoretically exact location of the feature(s) shall be defined with TEDs [see Figure 135a)].

When a geometrical tolerance is used to tolerance the orientation of a feature (or group of features), the theoretically exact orientation of the feature(s) shall be defined with TEDs [see Figure 135b)].

*NOTE* Examples are given in Figure 132.

When a profile tolerance is applied to a feature (or group of features), the theoretically exact profile or surface shall be defined with TEDs.

Figure 135 Use of theoretically exact dimensions (TEDs)

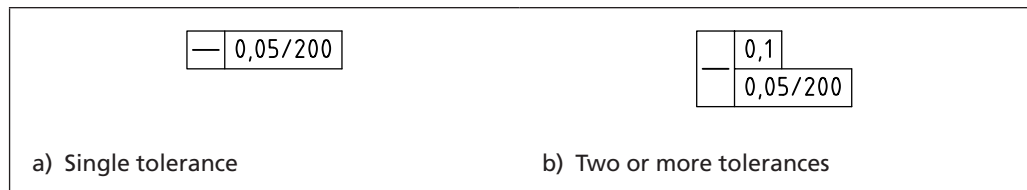


## 7.9 Restrictive specifications

If a tolerance of the same characteristic is applied to a restricted length, lying anywhere within the total extent of the feature, the value of the restricted length shall be added after the tolerance value and separated from it by an oblique stroke [see Figure 136a)].

*NOTE 1* If two or more tolerances of the same characteristic are to be indicated, they could be combined as shown in Figure 136b). The use of separate tolerance characteristic symbols or a single combined tolerance characteristic symbol are both permitted and have an identical meaning. Where a single combined tolerance symbol is used this is not equivalent to the composite tolerancing concept in ASME Y14.5 [1].

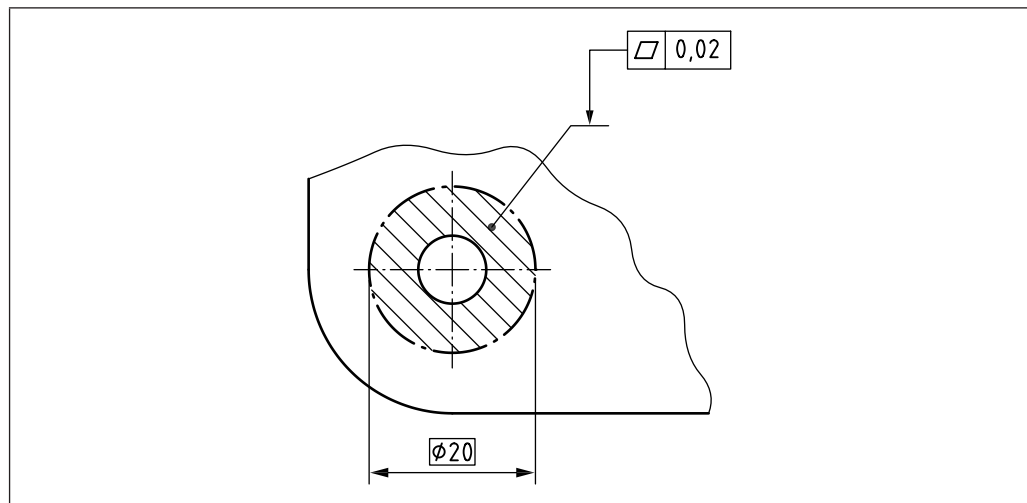
Figure 136 Examples of tolerances of the same characteristic



If a tolerance is applied to a restricted part of a feature only, this restriction shall be shown as a wide, long, dashed-dotted line and dimensioned (see Figure 137).

*NOTE 2* See BS ISO 128-24:1999, Table 2.

Figure 137 Tolerance applied to a restricted part of a feature

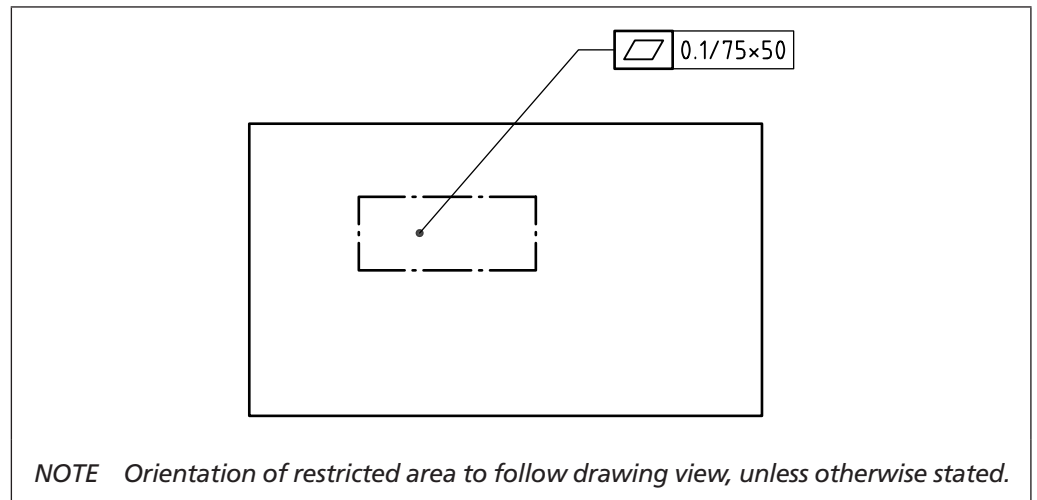


*NOTE 3* For information about the restricted part of a datum see BS EN ISO 1101:2013, 9.4.

*NOTE 4* Restrictions to the form of a feature within the tolerance zone are given in 5.3 and BS EN ISO 1101:2013, Clause 7.

If a tolerance is applied to a restricted part of a feature only, this shall be as shown in Figure 138.

Figure 138 Tolerance applied to an area

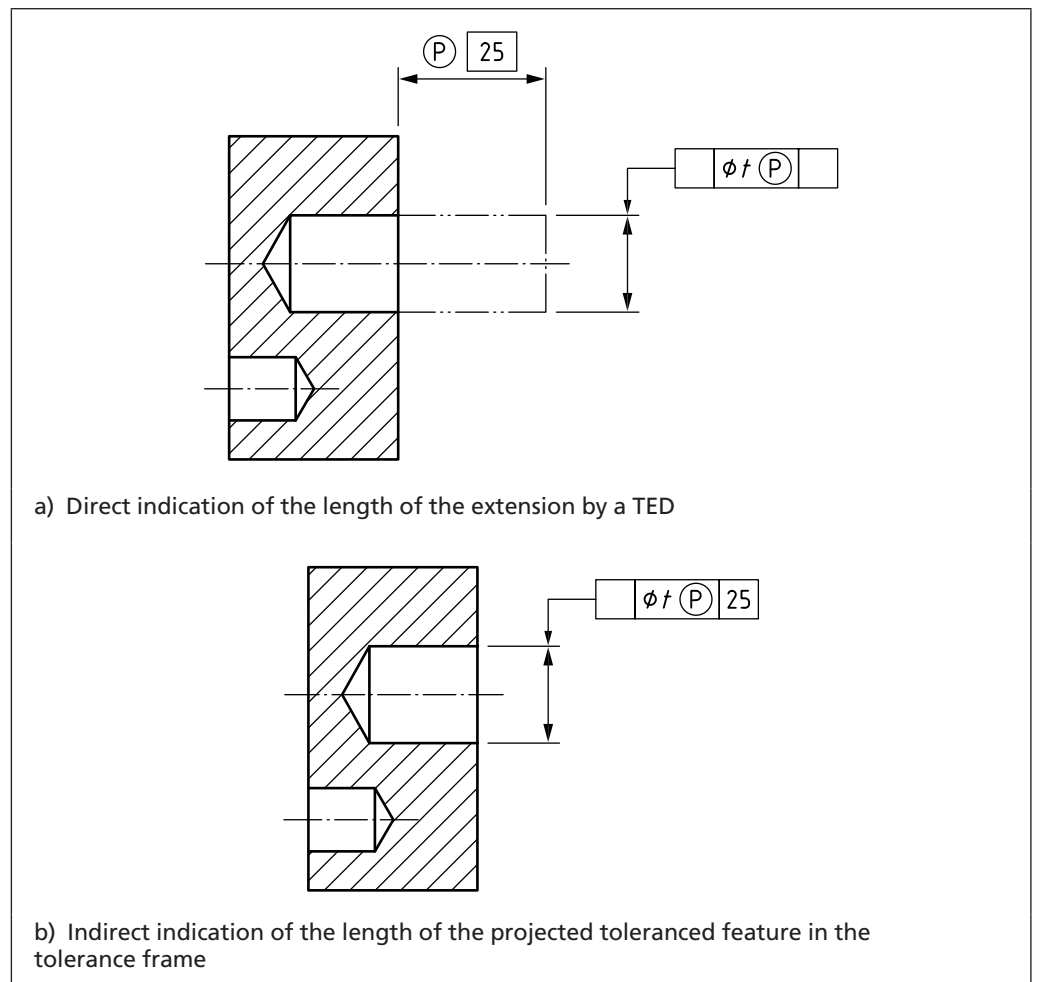


### 7.10 Projected tolerance zone

Projected tolerance zones shall be indicated by the specification modifier symbol  $\textcircled{P}$  (see example in Figure 139).

*NOTE* See BS EN ISO 1101 for additional information.

Figure 139 Two ways of indicating a geometrical specification with projected tolerance modifier

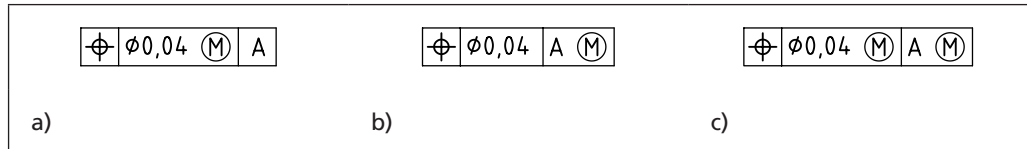


### 7.11 Maximum material requirement

The maximum material requirement shall be indicated by the specification modifier symbol  $\textcircled{M}$ . The symbol shall be placed after the specified tolerance value, datum letter or both as appropriate (see Figure 140).

*NOTE* See BS EN ISO 2692 for detailed rules.

Figure 140 Indication of the maximum material requirement

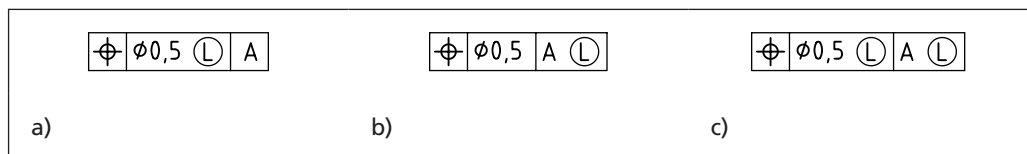


### 7.12 Least material requirement

The least material requirement shall be indicated by the specification modifier symbol  $\textcircled{L}$ . The symbol shall be placed after the specified tolerance value, datum letter or both as appropriate (see Figure 141).

*NOTE* See BS EN ISO 2692 for additional information.

Figure 141 Indication of the least material requirement

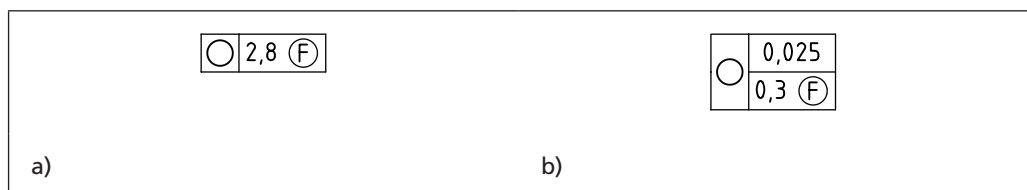


### 7.13 Free state condition

The free state condition for non-rigid parts shall be indicated by the specification modifier symbol  $\textcircled{F}$  placed after the specified tolerance value (see Figure 142).

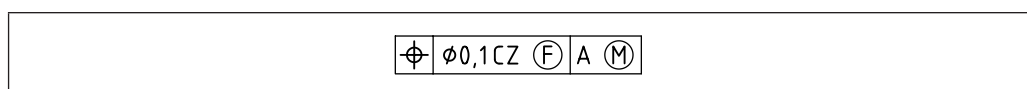
*NOTE 1* See BS ISO 10579 and BS EN ISO 1101 for additional information.

Figure 142 Free state condition



*NOTE 2* Several specification modifiers, e.g.  $\textcircled{P}$ ,  $\textcircled{M}$ ,  $\textcircled{L}$ ,  $\textcircled{F}$ , CZ and  $\angle\phi\Delta$ , could be used simultaneously in the same tolerance frame (see Figure 143).

Figure 143 Use of several specification modifiers





## 7.14 Interrelationship of geometrical tolerances

### COMMENTARY ON 7.14

*For functional reasons, one or more characteristics can be tolerated to define the geometrical deviations of a feature. Certain types of tolerances which limit the geometrical deviations of a feature can also limit other types of deviations for the same feature.*

Location tolerances of a feature shall control location deviation, orientation deviation and form deviation of this feature.

Orientation tolerances of a feature shall control orientation and form deviations of the feature.

Form tolerances of a feature shall only control form deviations of this feature.

## Section 8: Surface texture specification

### COMMENTARY ON SECTION 8

*Although the surface of a workpiece might appear smooth there is a complex surface structure or texture, comprising peaks and valleys, with its form and orientation derived from manufacturing and surface treatment processes. The texture of surfaces is critical to the durability and performance of interacting systems, particularly in the case of lubricated sliding and rolling contacts. It is therefore useful to be able to specify the surface texture and orientation required for the desired functionality.*

*BS 1134 offers an excellent introduction to surface texture specification.*

### 8.1 General

Indication of surface texture shall conform to the following standards, as appropriate.

BS 1134                      *Assessment of surface texture – Guidance and general information*

BS EN ISO 1302          *Geometrical Product Specifications (GPS) – Indication of surface texture in technical product documentation*

*NOTE 1 The correct application of BS EN ISO 1302 requires the use of the following standards.*

*NOTE 2 Although it is not usual practice to make secondary references such as these, BS EN ISO 1302 itself is of such significance that it is considered appropriate to ensure their inclusion in the BS 8888 kits in this way.*

BS EN ISO 8785          *Geometrical product specification (GPS) – Surface imperfections – Terms, definitions and parameters*

BS EN ISO 3274          *Geometrical Product Specifications (GPS) – Surface texture: Profile method – Nominal characteristics of contact (stylus) instruments*

BS EN ISO 4287          *Geometrical product specification (GPS) – Surface texture: Profile method – Terms, definitions and surface texture parameters*

BS EN ISO 4288          *Geometric Product Specification (GPS) – Surface texture – Profile method: Rules and procedures for the assessment of surface texture*

BS EN ISO 10135        *Geometrical product specifications (GPS) – Drawing indications for moulded parts in technical product documentation (TPD)*

BS EN ISO 16610-21    *Geometrical product specifications (GPS) – Filtration – Part 21: Linear profile filters: Gaussian filters*

BS EN ISO 12085        *Geometrical Product Specifications (GPS) – Surface texture: Profile method – Motif parameters*

BS EN ISO 13565-1     *Geometric Product Specifications (GPS) – Surface texture: Profile method – Surfaces having stratified functional properties – Part 1: Filtering and general measurement conditions*

BS EN ISO 13565-2     *Geometrical Product Specifications (GPS) – Surface texture: Profile method – Surfaces having stratified functional properties – Part 2: Height characterization using the linear material ration curve*

BS EN ISO 13565-3     *Geometrical product specifications (GPS) – Surface texture: Profile method – Surfaces having stratified functional*

*properties – Part 3: Height characterization using the material probability curve*

BS EN ISO 14253-1 *Geometrical Product Specifications (GPS) – Inspection by measurement of workpieces and measuring equipment – Part 1: Decision rules for proving conformity or non-conformity with specifications*

BS EN ISO 14660-1 *Geometrical Product Specifications (GPS) – Geometrical features – Part 1: General terms and definitions*

BS EN ISO 81714-1 *Design of graphical symbols for use in the technical documentation of products – Part 1: Basic rules*

*NOTE 3 The following documents detail different aspects of filtering which could be utilized to process surface texture readings.*

DD ISO/TS 16610-1 *Geometrical product specifications (GPS) – Filtration – Part 1: Overview and basic concepts*

DD ISO/TS 16610-20 *Geometrical product specifications (GPS) – Filtration – Part 20: Linear profile filters: Basic concepts*

DD ISO/TS 16610-22 *Geometrical product specifications (GPS) – Filtration – Part 22: Linear profile filters: Spline filters*

DD ISO/TS 16610-29 *Geometrical product specifications (GPS) – Filtration – Part 29: Linear profile filters: Spline wavelets*

DD ISO/TS 16610-40 *Geometrical product specifications (GPS) – Filtration – Part 40: Morphological profile filters: Basic concepts*

DD ISO/TS 16610-41 *Geometrical product specifications (GPS) – Filtration – Part 41: Morphological profile filters: Disk and horizontal line-segment filters*

DD ISO/TS 16610-49 *Geometrical product specifications (GPS) – Filtration – Part 49: Morphological profile filters: Scale space techniques*

## 8.2 Characterization

### COMMENTARY ON 8.2

*BS 1134 provides guidance and general information on the assessment of surface texture.*

### 8.2.1 General

The surface profile shall be measured to establish a range of geometrical parameters and is usually taken perpendicular to the direction of the lay unless otherwise indicated.

*NOTE Typically, a stylus device is drawn across the surface in the X direction, where Y is nominally parallel to the lay of the surface texture and Z is normal to the surface as shown in Figure 144a). The measuring device generates the total profile prior to the application of filters for the separation of roughness from waviness, form and signal noise.*

### 8.2.2 Profiles

#### COMMENTARY ON 8.2.2

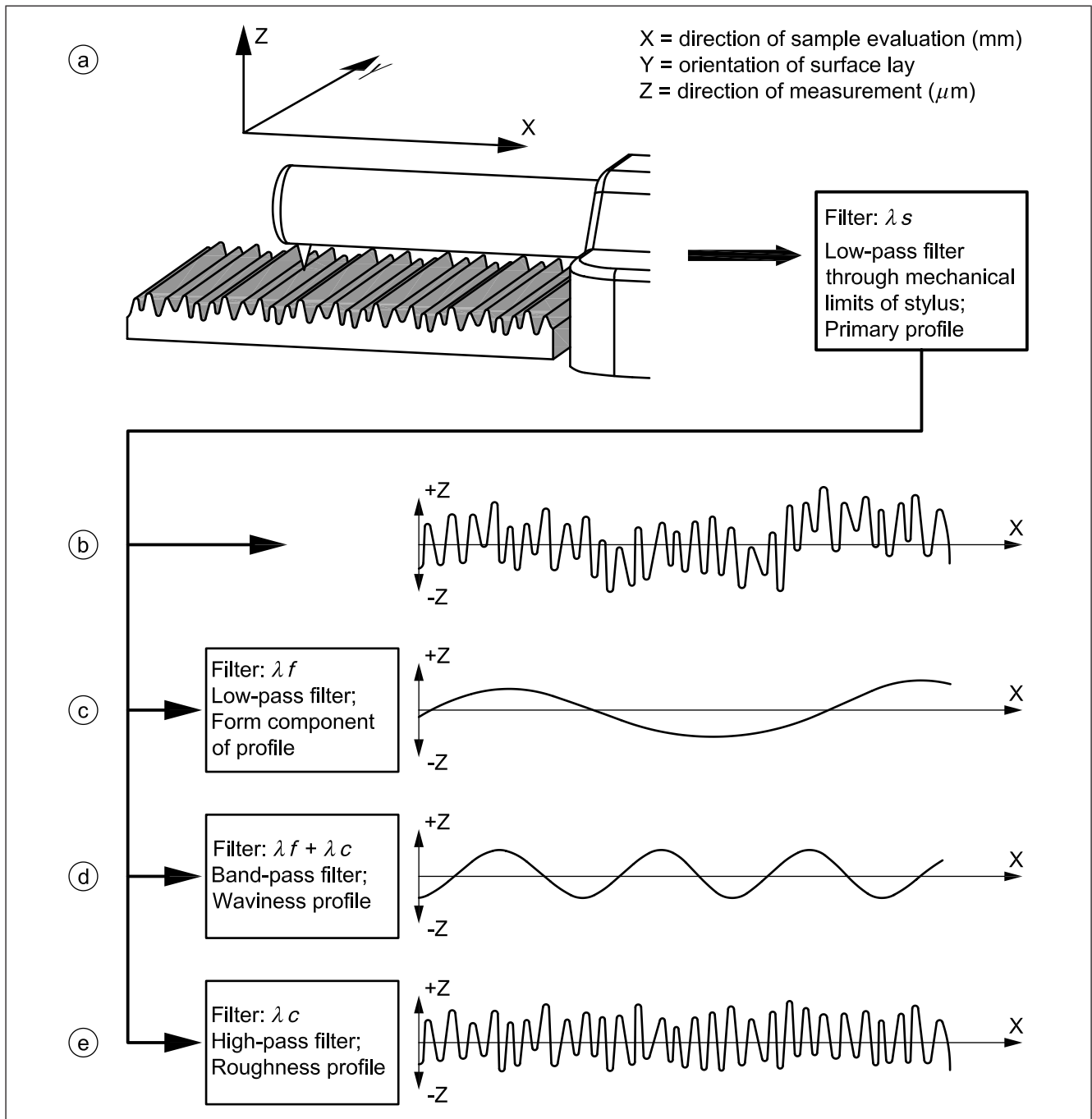
*The primary profile is the total profile after application of the low pass filter  $\lambda_s$ . In practice, this filter is often the mechanical limit of the measurement stylus. The profile includes waviness, roughness and longer wavelength components of form as shown in Figure 144b). The application of a low pass filter  $\lambda_f$  suppresses the waviness and roughness profiles while retaining the form component as shown in Figure 144c).*

The waviness profile shall be derived from the primary profile, the through application of a band pass filter where the  $\lambda_c$  suppresses the roughness and the  $\lambda_f$  suppresses the form component as shown in Figure 144d).

The roughness profile shall be derived from the primary profile through the application of a high pass filter where the  $\lambda_c$  filter suppresses both form and waviness as shown in Figure 144e).

The filter settings and derived evaluation length have a significant effect upon the measured result and shall be taken into consideration when specifying surface roughness parameters.

Figure 144 Use of several specification modifiers

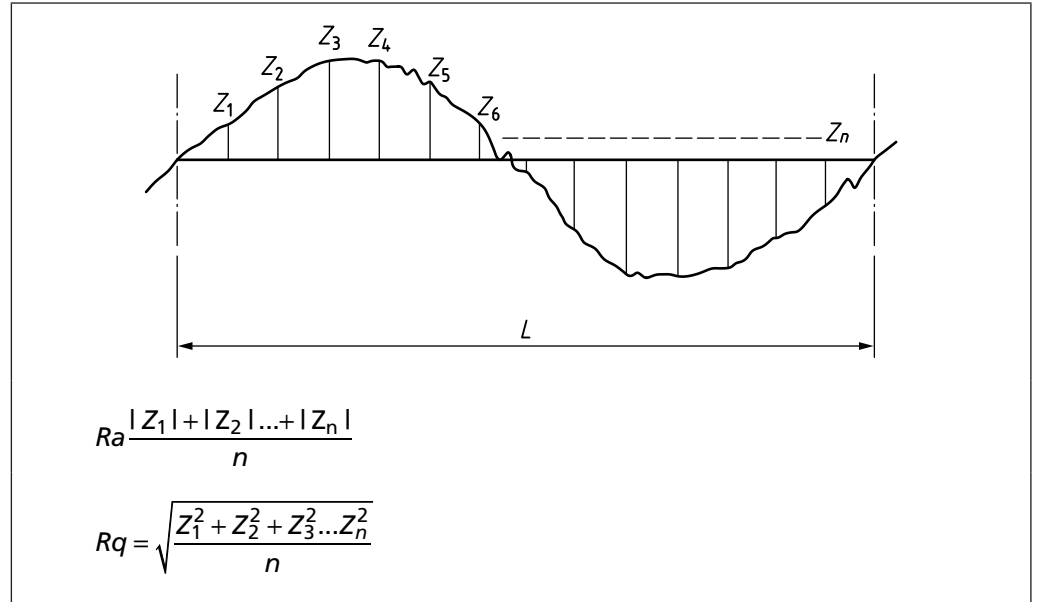


### 8.2.3 Roughness specifications

**COMMENTARY ON 8.2.3**

A wide range of surface roughness parameters can be specified and are described in BS 1134. The most commonly used are the arithmetical mean deviation ( $R_a$ ) and the root mean square deviation ( $R_q$ ) as shown in Figure 145.

Figure 145 Mathematical derivation of  $R_a$  and  $R_q$



The maximum peak height ( $R_p$ ) and maximum valley depth ( $R_v$ ) can be combined to produce the maximum profile height ( $R_z$ ) (see Figure 146) while surface skewness can be evaluated using  $R_{sk}$  (see Figure 147).

Figure 146 Peak height ( $R_p$ ), valley depth ( $R_v$ ) and maximum height of profile ( $R_z$ )

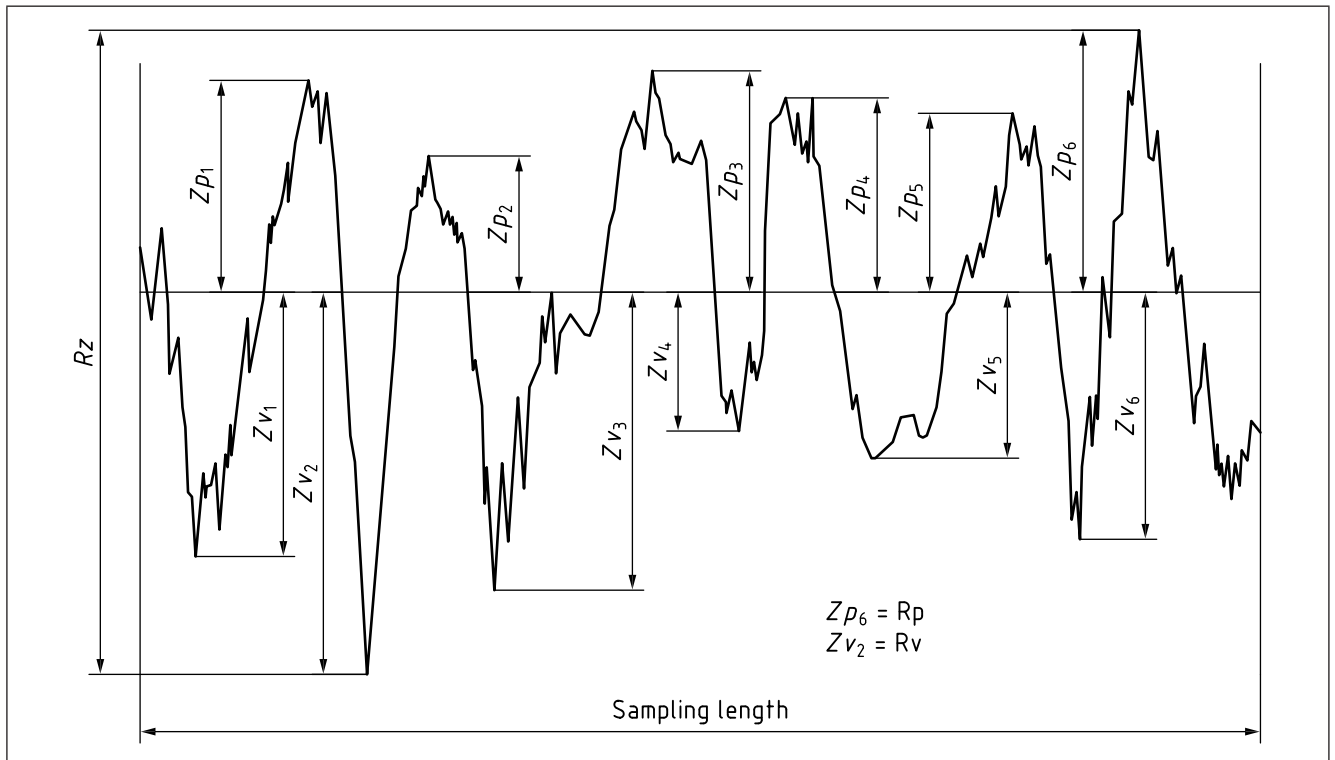
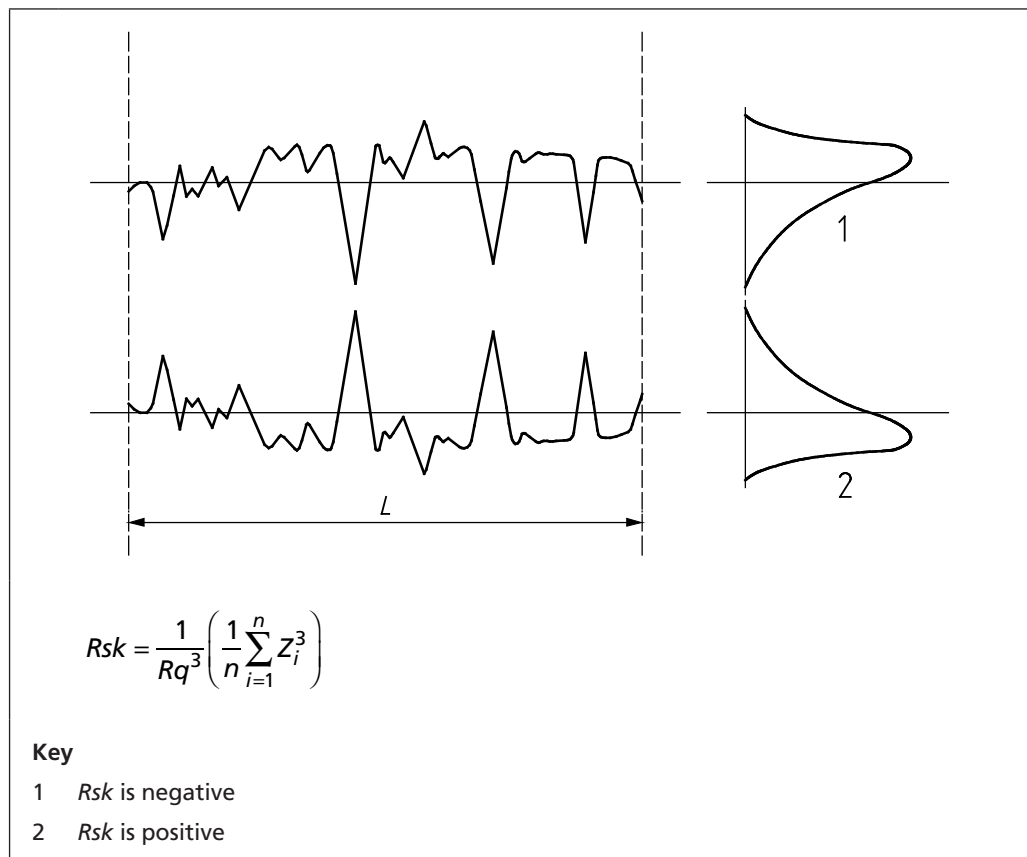


Figure 147 Mathematical derivation of surface skewness ( $R_{sk}$ )

Although it is common to indicate only the desired surface texture specification, the filter and evaluation length settings shall also be specified.

*NOTE 1 Failure to provide these settings will result in a lengthy procedure prior to establishing the correct settings for the sampled surface, with subsequent cost implications.*

For non-periodic surfaces measuring  $R_a$  and  $R_q$  the standard cut-off settings shall be as shown in Table 19, while those for  $R_z$  shall be as shown in Table 20.

*NOTE 2 Cut-off settings for periodic surfaces when measuring any surface roughness parameter are dependent upon the mean width of profile elements ( $RS_m$ ) value as shown in Figure 148 prior to selection from Table 21.*

Table 19 Estimates for choosing roughness sampling lengths for the measurement of non-periodic profiles ( $R_a$ )

$R_a$	Roughness sampling length	Roughness evaluation length
$R_a/\mu\text{m}$	$l_r/\text{mm}$	$l_n/\text{mm}$
$0,006 < R_a \leq 0,02$	0,08	0,40
$0,02 < R_a \leq 0,1$	0,25	1,25
$0,1 < R_a \leq 2$	0,80	4,00
$2 < R_a \leq 10$	2,50	12,50
$10 < R_a \leq 80$	8,00	40,00

Table 20 Estimates for choosing roughness sampling lengths for the measurement of non-periodic profiles ( $R_z$ )

$R_z$	Roughness sampling length	Roughness evaluation length
$Rz1max/\mu m$	$l_r/mm$	$l_n/mm$
$0,025 < Rz Rz1max \leq 0,1$	0,08	0,40
$0,1 < Rz Rz1max \leq 0,5$	0,25	1,25
$0,5 < Rz Rz1max \leq 10$	0,80	4,00
$10 < Rz Rz1max \leq 50$	2,50	12,50
$50 < Rz Rz1max \leq 200$	8,00	40,00

NOTE 1  $R_z$  is used when measuring  $R_z$ ,  $R_v$ ,  $R_p$ ,  $R_c$  and  $R_t$ .

NOTE 2  $Rz1max$  is used only when measuring  $Rz1max$ ,  $Rv1max$ ,  $Pr1max$  and  $Rc1max$ .

Figure 148 Derivation of mean width of profile element ( $RS_m$ )

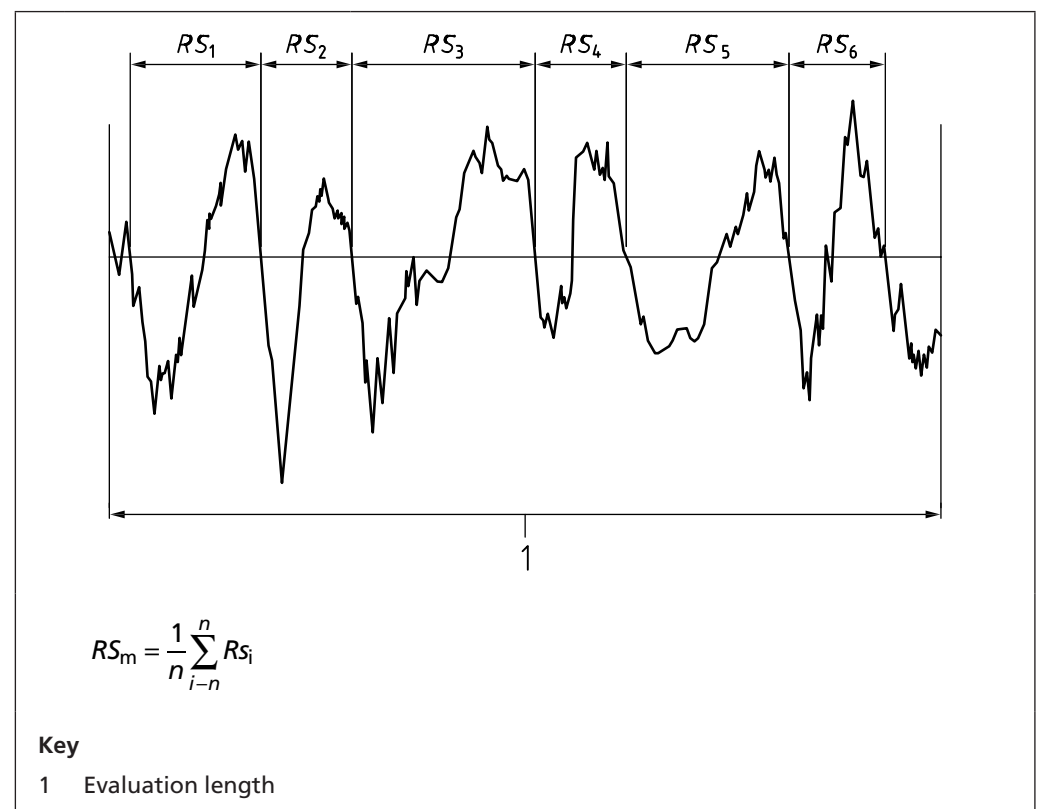


Table 21 Estimates for choosing roughness sampling lengths for the measurement of periodic profiles

$RS_m$	Roughness sampling length	Roughness evaluation length
$RS_m/mm$	$l_r/mm$	$l_n/mm$
$0,013 < RS_m \leq 0,04$	0,08	0,40
$0,04 < RS_m \leq 0,13$	0,25	1,25
$0,13 < RS_m \leq 0,4$	0,80	4,00
$0,4 < RS_m \leq 1,3$	2,50	12,50
$1,3 < RS_m \leq 4$	8,00	40,00

### 8.2.4 16% rule

When sampling surface texture not more than 16% of samples shall fall outside of the specification. If the Max or Min indication is made no samples shall fall outside of the specification.

*NOTE BS EN ISO 4288 provides further guidance on a simplified procedure for roughness inspection.*

Where the 16% rule is employed the test shall be stopped if:

- the first measurement does not exceed 70% of the specified value;
- the first three measurements are within specification;
- not more than one of the first six measurements exceeds the specification;
- not more than two of the first twelve exceed the specification.

## 8.3 Drawing indication of surface texture specification

*NOTE BS EN ISO 1302 provides a full description for the indication of surface specification.*

The surface specification shall be indicated through the use of the graphical symbol shown in Figure 149, while the positions of various requirements shall be indicated as shown in Figure 150.

Figure 149 Surface texture graphical symbol

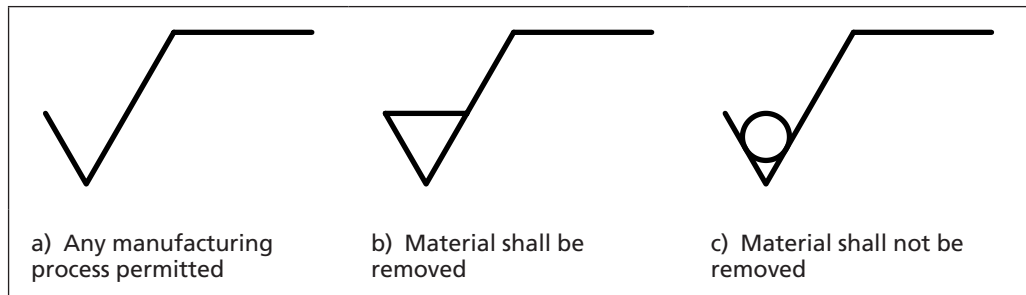
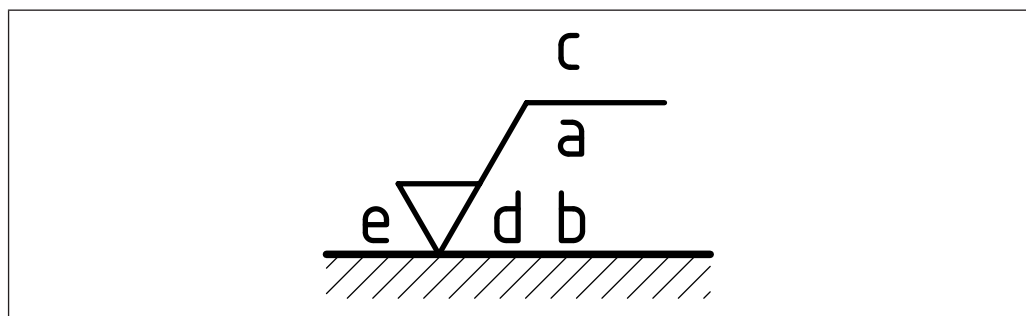


Figure 150 Positions (a to e) for location of texture requirements



The surface texture requirement shall be in position “a” and indicate the sampling length or transmission band, separated by oblique (/), then texture parameter designation (with limit indicator if required), separation by double space and numerical limit. If a second specification is required this shall be in position “b”; further specifications require the enlargement of the symbol.


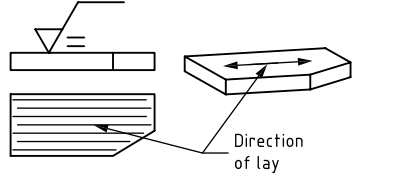

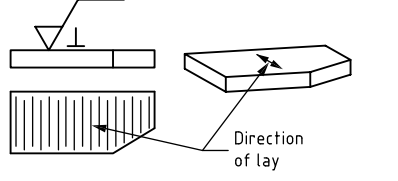

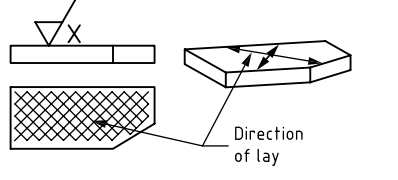

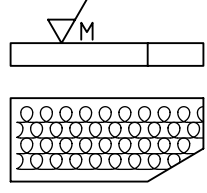

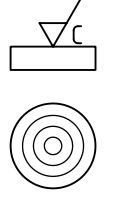

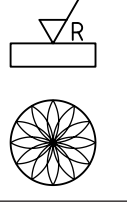

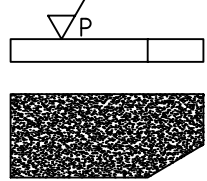
The manufacturing method, treatment or other process if required shall be in position “c”.



Surface lay and orientation (as shown in Table 22) relative to the plane of projection shall be shown in position "d".

Indication of any machining allowance as a numerical value in mm shall be shown in position "e".

Table 22 Indication of surface lay<sup>A)</sup>

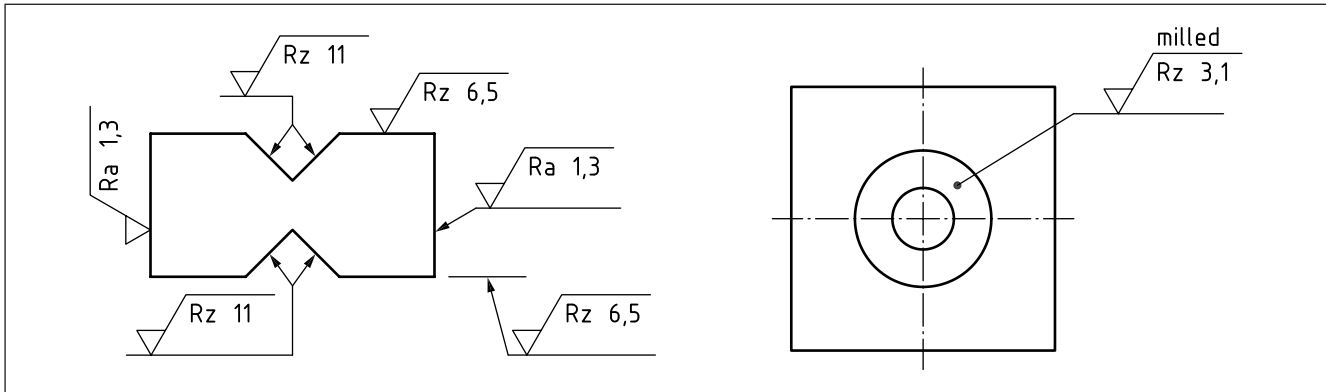
Graphical symbol	Interpretation and example	
	Parallel to plane of projection of view in which symbol is used	
	Perpendicular to plane of projection of view in which symbol is used	
	Crossed in two oblique directions relative to plane of projection of view in which symbol is used	
	Multi-directional	
	Approx. circular relative to centre of surface to which symbol applies	
	Approx. radial relative to centre of surface to which symbol applies	
	Lay is particulate, non-directional, or protuberant	

<sup>A)</sup> If it is necessary to specify a surface pattern which is not clearly defined by these symbols, this shall be achieved by the addition of a suitable note to the drawing.

## 8.4 Position and orientation of graphical symbol

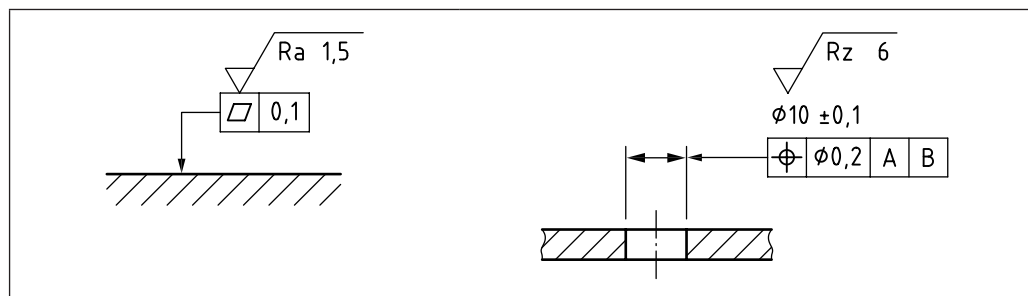
The graphical symbol and information shall be orientated so that they are readable from the bottom or right-hand side of the drawing in accordance with BS ISO 129-1. The symbol or terminating leader shall point at the surface from outside the workpiece, either to the outline or to an extension of it (see Figure 151).

Figure 151 Attachment of surface texture requirement to workpiece



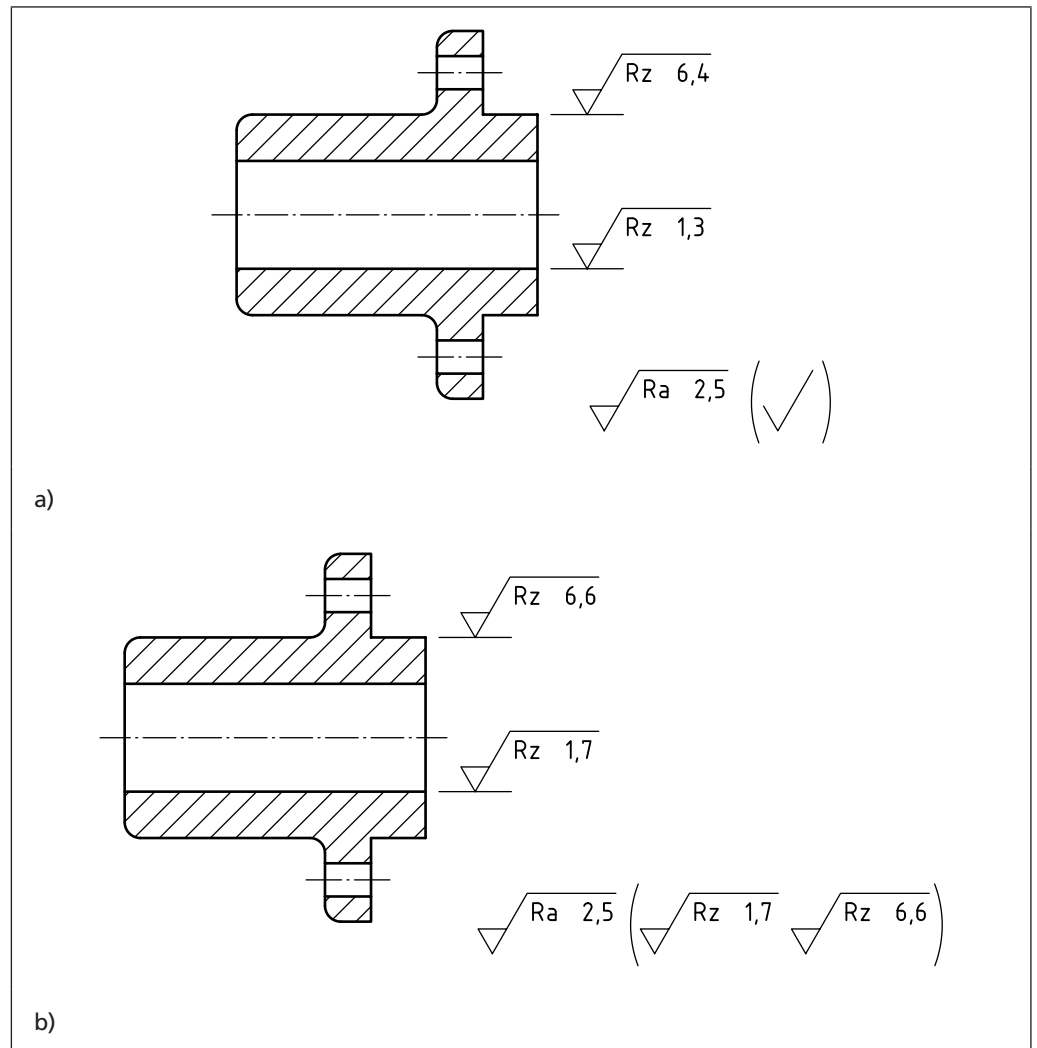
*NOTE 1* The surface texture requirement can also be attached to a tolerance feature indicator where geometrical tolerancing is applied to BS EN ISO 1101, as shown in Figure 152.

Figure 152 Surface texture requirement: Geometrical tolerance indication



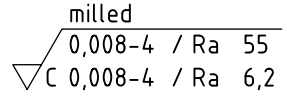
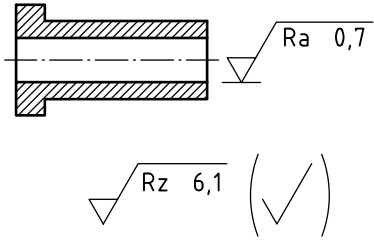
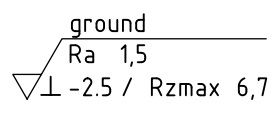
Where the same surface texture is required on the majority of surfaces the requirement shall be placed close to the title block of the drawing. The symbol representing general requirement shall be followed by either a basic symbol [Figure 153a)] or the actual requirements [Figure 153b)] in parentheses in order to indicate that other surface texture requirements are specified.

Figure 153 Simplified indication: Majority of surfaces with same surface texture requirement



NOTE 2 BS EN ISO 1302 provides a full description of the application of surface texture requirements for engineering drawings with extensive examples of the application of surface texture specification, some of which are reproduced in Table 23.

Table 23 Example application of surface texture

Requirement	Example								
<p>Surface roughness:</p> <ul style="list-style-type: none"> <li>- bilateral specification;</li> <li>- upper specification limit <math>Ra = 55 \mu\text{m}</math>;</li> <li>- lower specification limit <math>Ra = 6,2 \mu\text{m}</math>;</li> <li>- both "16 %-rule", default (BS EN ISO 4288);</li> <li>- both transmission band 0,008-4 mm;</li> <li>- default evaluation length (5 mm × 4 mm = 20 mm) (BS EN ISO 4288);</li> <li>- surface lay approximately circular around the centre;</li> <li>- manufacturing process, milling.</li> </ul> <p><i>NOTE U and L are not stated because there is no doubt.</i></p>	 <p>milled  <math>\sqrt{0,008-4 / Ra 55}</math>  <math>\sqrt{C 0,008-4 / Ra 6,2}</math></p>								
<p>One surface has a specific requirement for a surface roughness:</p> <ul style="list-style-type: none"> <li>- one single, unilateral/upper specification limit;</li> <li>- <math>Ra = 0,7 \mu\text{m}</math>;</li> <li>- "16 %-rule", default;</li> <li>- default transmission band (BS EN ISO 4288 and BS EN ISO 3274);</li> <li>- default evaluation length (5 × <math>\lambda c</math>) (BS EN ISO 4288);</li> <li>- surface lay, no requirement;</li> <li>- manufacturing process shall remove material.</li> </ul> <p>Unspecified surfaces have a roughness requirement of:</p> <ul style="list-style-type: none"> <li>- one single, unilateral/upper specification limit;</li> <li>- <math>Rz = 6,1 \mu\text{m}</math>;</li> <li>- "16 %-rule", default (BS EN ISO 4288);</li> <li>- default transmission band (BS EN ISO 4288 and BS EN ISO 3274);</li> <li>- default evaluation length (5 × <math>\lambda c</math>) (BS EN ISO 4288);</li> <li>- surface lay, no requirement;</li> <li>- manufacturing process shall remove material.</li> </ul>	 <p><math>Ra 0,7</math>  <math>Rz 6,1</math> (✓)</p>								
<p>Surface roughness:</p> <ul style="list-style-type: none"> <li>- two, unilateral/upper specification limits:             <table style="width: 100%; border: none;"> <tr> <td style="width: 50%;">1) <math>Ra = 1,5 \mu\text{m}</math>;</td> <td style="width: 50%;">5) <math>Rz \text{ max} = 6,7 \mu\text{m}</math>;</td> </tr> <tr> <td>2) "16 %-rule", default (BS EN ISO 4288);</td> <td>6) max-rule;</td> </tr> <tr> <td>3) default transmission band (BS EN ISO 4288 and BS EN ISO 3274);</td> <td>7) transmission band – 2,5 mm (BS EN ISO 3274);</td> </tr> <tr> <td>4) default evaluation length (5 × <math>\lambda c</math>) (BS EN ISO 4288);</td> <td>8) evaluation length default (5 × 2,5 mm);</td> </tr> </table> </li> <li>- surface lay approximately perpendicular on the projection plane;</li> <li>- manufacturing process, grinding.</li> </ul>	1) $Ra = 1,5 \mu\text{m}$ ;	5) $Rz \text{ max} = 6,7 \mu\text{m}$ ;	2) "16 %-rule", default (BS EN ISO 4288);	6) max-rule;	3) default transmission band (BS EN ISO 4288 and BS EN ISO 3274);	7) transmission band – 2,5 mm (BS EN ISO 3274);	4) default evaluation length (5 × $\lambda c$ ) (BS EN ISO 4288);	8) evaluation length default (5 × 2,5 mm);	 <p>ground  <math>\sqrt{Ra 1,5}</math>  <math>\sqrt{\perp -2.5 / Rzmax 6,7}</math></p>
1) $Ra = 1,5 \mu\text{m}$ ;	5) $Rz \text{ max} = 6,7 \mu\text{m}$ ;								
2) "16 %-rule", default (BS EN ISO 4288);	6) max-rule;								
3) default transmission band (BS EN ISO 4288 and BS EN ISO 3274);	7) transmission band – 2,5 mm (BS EN ISO 3274);								
4) default evaluation length (5 × $\lambda c$ ) (BS EN ISO 4288);	8) evaluation length default (5 × 2,5 mm);								

## 8.5 Statistical tolerancing

### COMMENTARY ON 8.5

*Although not currently standardized within the ISO GPS system, it is recommended that where statistical methods have been used to determine tolerance values these values are identified as such on the TPS by the use of the  $\langle \text{ST} \rangle$  symbol and are accompanied by a note stating the appropriate process control criteria to be associated to the tolerance.*

*The process control criteria for demonstrating conformity should be agreed between the producer and integrator and is in addition to satisfying the statistical tolerance specification limits.*

*Where appropriate, the statistically calculated value and a more restrictive theoretical worst case arithmetic value should be represented concurrently in the TPS to provide the option to the producer of either achieving the more restrictive value or achieving the less restrictive statistical value with process control criteria applied.*

*Differentiating statistically derived tolerances via  $\langle \text{ST} \rangle$  symbology and/or a note also identifies that the tolerance has been used in statistical analysis and as such, when added to other contributory tolerances, could exceed the overall product requirement specification limits when calculated using theoretical worst case tolerance accumulation.*

*It is recommended that appropriate statistical methods, based on the specific application, are used in both the calculation and control of the tolerances, and that physical validation is used to demonstrate achievement of the product requirement specification when statistical tolerances and associated process control criteria are applied.*

Where used, the  $\langle \text{ST} \rangle$  symbol shall be placed after the feature tolerance and any modifiers in a tolerance frame or after any linear, size or angle dimension.

**NOTE** See BS EN ISO 14253-1:2013, 5.1.

## Section 9: Symbols and abbreviations

### 9.1 Symbols and abbreviations

#### 9.1.1 General

Abbreviations (text equivalents) used in a TPS shall be the same in the singular and plural. A full stop shall not be used except where an abbreviation forms a word (e.g. NO. as an abbreviation for “number”).

*NOTE* Where possible, abbreviations should be avoided (see 9.1.2).

Symbols used for physical quantities and units of measurement shall conform to the following standards, as appropriate.

BS EN ISO 80000-1	<i>Quantities and units – Part 1: General</i>
BS EN ISO 80000-2	<i>Quantities and units – Part 2: Mathematical signs and symbols to be used in the natural sciences and technology</i>
BS EN ISO 80000-3	<i>Quantities and units – Part 3: Space and time</i>
BS EN ISO 80000-4	<i>Quantities and units – Part 4: Mechanics</i>
BS EN ISO 80000-5	<i>Quantities and units – Part 5: Thermodynamics</i>
BS EN 80000-6	<i>Quantities and units – Part 6: Electromagnetism</i>
BS ISO 80000-7	<i>Quantities and units – Part 7: Light</i>
BS EN ISO 80000-8	<i>Quantities and units – Part 8: Acoustics</i>
BS EN ISO 80000-9	<i>Quantities and units – Part 9: Physical chemistry and molecular physics</i>
BS EN ISO 80000-10	<i>Quantities and units – Part 10: Atomic and nuclear physics</i>
BS EN ISO 80000-11	<i>Quantities and units – Part 11: Characteristic numbers</i>
BS EN ISO 80000-12	<i>Quantities and units – Part 12: Solid state physics</i>
BS EN 80000-13	<i>Quantities and units – Part 13: Information science and technology</i>
BS EN 80000-14	<i>Quantities and units – Part 14: Telebiometrics related to human physiology</i>

#### 9.1.2 Standard symbols and abbreviations

##### *COMMENTARY ON 9.1.2*

*In the existing environment of outsourcing across national borders, every effort is being made to make the use of GPS (geometrical product specification) independent of language through the adoption of standard symbology. It is for this reason that the continued use of abbreviations is deprecated.*

Where particular specification requirements cannot be expressed using the available GPS system, full text description shall be employed.

*NOTE 1* It is suggested that, where such a requirement occurs frequently, this be drawn to the attention of the relevant ISO committee through the appropriate BSI Technical Committee.

For diagrams used in technical applications, a library of harmonized graphical symbols has been developed with close cooperation between ISO and IEC. This is published in the following series of standards and these shall be applied wherever practicable to improve the universal applicability of the TPS.

BS ISO 14617-1	<i>Graphical symbols for diagrams – Part 1: General information and indexes</i>
BS ISO 14617-2	<i>Graphical symbols for diagrams – Part 2: Symbols having general application</i>
BS ISO 14617-3	<i>Graphical symbols for diagrams – Part 3: Connections and related devices</i>
BS ISO 14617-4	<i>Graphical symbols for diagrams – Part 4: Actuators and related devices</i>
BS ISO 14617-5	<i>Graphical symbols for diagrams – Part 5: Measurement and control devices</i>
BS ISO 14617-6	<i>Graphical symbols for diagrams – Part 6: Measurement and control functions</i>
BS ISO 14617-7	<i>Graphical symbols for diagrams – Part 7: Basic mechanical components</i>
BS ISO 14617-8	<i>Graphical symbols for diagrams – Part 8: Valves and dampers</i>
BS ISO 14617-9	<i>Graphical symbols for diagrams – Part 9: Pumps, compressors and fans</i>
BS ISO 14617-10	<i>Graphical symbols for diagrams – Part 10: Fluid power converters</i>
BS ISO 14617-11	<i>Graphical symbols for diagrams – Part 11: Devices for heat transfer and heat engines</i>
BS ISO 14617-12	<i>Graphical symbols for diagrams – Part 12: Devices for separating, purification and mixing</i>

Symbols appropriate to TPS are provided and detailed throughout the suite of documents cross-referenced from this British Standard, and these shall be used where appropriate.

*NOTE 2 It is strongly recommended that abbreviations not be used.*

Where, in particular technical fields, certain abbreviations are in common use and generally understood, it is accepted that these can continue to be used, but new abbreviations shall not be introduced.

*NOTE 3 Former practice has resulted in certain abbreviations becoming accepted as symbols and these should not be considered to provide precedence for the proliferation of abbreviations.*

## Section 10: Document handling

### 10.1 Types of documentation

#### 10.1.1 General

*COMMENTARY ON 10.1.1*

*The careful targeting of TPD to known or intended users can greatly assist the accuracy with which the specification is converted into the final product.*

While precision and avoidance of ambiguity are always paramount, the means employed to convey this information shall be seen to match the capability, or potential capability, of the available or achievable manufacturing facility.

*NOTE Specification beyond this level is unlikely to produce satisfactory results and can often prove expensive, both in terms of the cost of the over-specification itself and in terms of inadequate or unacceptable product.*

#### 10.1.2 Presentation media

##### 10.1.2.1 General

The presentation of the drawings shall conform to the following standards, as appropriate.

BS EN ISO 5457      *Technical product documentation – Sizes and layout of drawing sheets*

BS EN ISO 7200      *Technical product documentation – Data fields in title blocks and document headers*

BS ISO 7573        *Technical product documentation – Parts lists*

##### 10.1.2.2 Format

Drawing sheets and other documents shall be presented in one of the following formats:

- a) landscape: intended to be viewed with the longest side of the sheet horizontal;
- b) portrait: intended to be viewed with the longest side of the sheet vertical.

*NOTE Contrary to BS EN ISO 5457, A4 sheets can be used in landscape or portrait mode.*

### 10.2 Security

#### 10.2.1 Introduction

Many TPSs have minimal requirements for security, other than that provided by general handling and storage procedures. However, where specific need for a general level of security is identified, the requirements in 10.2.2, 10.2.3 and 10.2.4 shall be met.

#### 10.2.2 General security

Procedures for ensuring the security of TPDs and TPSs shall conform to the following standard.

BS EN ISO 11442      *Technical product documentation – Document management*



### 10.2.3 Enhanced security

Where enhanced security is claimed, the requirements of Annex D shall be met, in addition to those in 10.2.4.

### 10.2.4 Security level identification

The level of security attributed to any given TPS shall be clearly identified by the relevant marking placed adjacent to the title or title block of every TPD making up that TPS.

## 10.3 Storage

Methods for storage and retrieval of the document shall conform to the following standards, as appropriate.

BS EN ISO 6428      *Technical drawings – Requirements for microcopying*

BS EN ISO 11442    *Technical product documentation – Document management*

## 10.4 Marking

### 10.4.1 General

Technical product documents shall be marked to indicate which standards, or system of standards, are to govern their interpretation in a prominent location.<sup>7)</sup>

Technical product documents prepared in accordance with this British Standard shall be prepared in accordance with the ISO system.

*NOTE* The marking of a TPD or TPS with the number of this standard constitutes a claim that the appropriate requirements of all relevant cross-referenced standards, in addition to the requirements directly stated in this British Standard, have been met. Attention is drawn to the date of issue principle (3.1.3).

### 10.4.2 Enhanced security

TPDs conforming to Annex D, shall be marked in a prominent location with the number of this standard, followed by the suffix "/D", i.e.:

CONFORMS TO BS 8888/D

## 10.5 Protection notices

Where appropriate to place restrictions on the use of TPD, the following standard shall be applied.

BS ISO 16016      *Technical product documentation – Protection notices for restricting the use of documents and products*

---

<sup>7)</sup> Marking BS 8888:2017 on or in relation to a product represents a manufacturer's declaration of conformity, i.e. a claim by or on behalf of the manufacturer that the product meets the requirements of the standard. The accuracy of the claim is solely the claimant's responsibility. Such a declaration is not to be confused with third-party certification of conformity.

**Annex A**  
(normative)

## Normative references

The following referenced documents are indispensable for the application of this document. For dated references, only the edition cited applies. For undated references, the latest edition of the referenced document (including any amendments) applies.

BS 1134, *Assessment of surface texture – Guidance and general information*

BS 1916-1, *Limits and fits for engineering – Part 1: Guide to limits and tolerances*

BS 1916-2, *Limits and fits for engineering – Part 2: Guide to the selection of fits in BS 1916-1*

BS 1916-3, *Limits and fits for engineering – Part 3: Guide to tolerances, limits and fits for large diameters*

BS 3238-1, *Graphical symbols for components of servo-mechanisms – Part 1: Transducers and Magnetic Amplifiers*

BS 3238-2, *Graphical symbols for components of servo-mechanisms – Part 2: General Servo-mechanisms*

BS 3734-1, *Rubber – Tolerances for products – Part 1: Dimensional tolerances<sup>8)</sup>*

BS 4500, *Limits and fits – Guidance for system of cone (taper) fits and tolerances for cones from  $C = 1:3$  to  $1:500$ , lengths from 6 mm to 630 mm and diameters up to 500 mm*

BS 7010, *Code of practice for a system of tolerances for the dimensions of plastic mouldings*

BS EN 80000-6, *Quantities and units – Part 6: Electromagnetism*

BS EN 80000-13, *Quantities and units – Part 13: Information science and technology*

BS EN 80000-14, *Quantities and units – Part 14: Telebiometrics related to human physiology*

BS EN ISO 1, *Geometrical product specifications (GPS) – Standard reference temperature for the specification of geometrical and dimensional properties*

BS EN ISO 128-20, *Technical drawings – General principles of presentation – Part 20: Basic conventions for lines*

BS EN ISO 128-21, *Technical drawings – General principles of presentation – Part 21: Preparation of lines by CAD systems*

BS EN ISO 286-1, *Geometrical product specifications (GPS) – ISO code system for tolerances on linear sizes – Part 1: Basis of tolerances, deviations and fits*

BS EN ISO 286-2, *Geometrical product specifications (GPS) – ISO code system for tolerances on linear sizes – Part 2: Tables of standard tolerance classes and limit deviations for holes and shafts*

BS EN ISO 1101, *Geometrical product specifications (GPS) – Geometrical tolerancing – Tolerances of form, orientation, location and run-out<sup>9)</sup>*

BS EN ISO 1119, *Geometrical product specifications (GPS) – Series of conical tapers and taper angles*

BS EN ISO 1302, *Geometrical Product Specifications (GPS) – Indication of surface texture in technical product documentation*

<sup>8)</sup> Withdrawn.

<sup>9)</sup> This standard also gives informative references to BS EN ISO 1101:2013.

- BS EN ISO 1660, *Technical drawings – Dimensioning and tolerancing of profiles*
- BS EN ISO 2162-1, *Technical product documentation – Springs – Part 1: Simplified representation*
- BS EN ISO 2162-2, *Technical product documentation – Springs – Part 2: Presentation of data for cylindrical helical compression springs*
- BS EN ISO 2203, *Technical drawings – Conventional representation of gears*
- BS EN ISO 2553, *Welded and allied processes – Symbolic representation on drawings – Welded joints*
- BS EN ISO 2692, *Geometrical product specifications (GPS) – Geometrical tolerancing – Maximum material requirement (MMR), least material requirement (LMR) and reciprocity requirement (RPR)*
- BS EN ISO 3040, *Geometrical product specifications (GPS) – Dimensioning and tolerancing – Cones*
- BS EN ISO 3098-0, *Technical Product Documentation – Lettering – Part 0: General requirements<sup>10)</sup>*
- BS EN ISO 3098-2, *Technical product documentation – Lettering – Part 2: Latin alphabet, numerals and marks*
- BS EN ISO 3098-3, *Technical product documentation – Lettering – Part 3: Greek alphabet*
- BS EN ISO 3098-4, *Technical product documentation – Lettering – Part 4: Diacritical and particular marks for the Latin alphabet*
- BS EN ISO 3098-5, *Technical product documentation – Lettering – Part 5: CAD lettering of the Latin alphabet, numerals and marks*
- BS EN ISO 3098-6, *Technical product documentation – Lettering – Part 6: Cyrillic alphabet*
- BS EN ISO 3274, *Geometrical Product Specifications (GPS) – Surface texture: Profile method – Nominal characteristics of contact (stylus) instruments*
- BS EN ISO 4063, *Welding and allied processes – Nomenclature of processes and reference numbers*
- BS EN ISO 4287, *Geometrical product specification (GPS) – Surface texture: Profile method – Terms, definitions and surface texture parameters*
- BS EN ISO 4288, *Geometric Product Specification (GPS) – Surface texture – Profile method: Rules and procedures for the assessment of surface texture*
- BS EN ISO 5261, *Technical drawings – Simplified representation of bars and profile sections*
- BS EN ISO 5456-2, *Technical drawings – Projection methods – Part 2: Orthographic representations*
- BS EN ISO 5456-3, *Technical drawings – Projection methods – Part 3: Axonometric representations*
- BS EN ISO 5457, *Technical product documentation – Sizes and layout of drawing sheets*
- BS EN ISO 5458, *Geometrical Product Specifications (GPS) – Geometrical tolerancing – Positional tolerancing*
- BS EN ISO 5459, *Geometrical product specifications (GPS) – Geometrical tolerancing – Datums and datum systems<sup>11)</sup>*

---

<sup>10)</sup> Withdrawn.

<sup>11)</sup> This standard also gives an informative reference to BS EN ISO 5459:2011.

- BS EN ISO 5845-1, *Technical drawings – Simplified representation of the assembly of parts with fasteners – Part 1: General principles*
- BS EN ISO 6410-1, *Technical drawings – Screw threads and threaded parts – Part 1: General conventions*
- BS EN ISO 6410-2, *Technical drawings – Screw threads and threaded parts – Part 2: Screw thread inserts*
- BS EN ISO 6410-3, *Technical drawings – Screw threads and threaded parts – Part 3: Simplified representation*
- BS EN ISO 6411, *Technical drawings – Simplified representation of centre holes*
- BS EN ISO 6412-1, *Technical drawings – Simplified representation of pipelines – Part 1: General rules and orthogonal representation*
- BS EN ISO 6412-2, *Technical drawings – Simplified representation of pipelines – Part 2: Isometric projection*
- BS EN ISO 6412-3, *Technical drawings – Simplified representation of pipelines – Part 3: Terminal features of ventilation and drainage systems*
- BS EN ISO 6413, *Technical drawings – Representation of splines and serrations*
- BS EN ISO 6428, *Technical drawings – Requirements for microcopying*
- BS EN ISO 7083, *Technical drawings – Symbols for geometrical tolerancing – Proportions and dimensions*
- BS EN ISO 7200, *Technical product documentation – Data fields in title blocks and document headers*
- BS EN ISO 8015, *Geometrical product specifications (GPS) – Fundamentals – Concepts, principles and rules*
- BS EN ISO 8062-1, *Geometrical product specifications (GPS) – Dimensional and geometrical tolerances for moulded parts – Part 1: Vocabulary*
- BS EN ISO 8062-3, *Geometrical product specifications (GPS) – Dimensional and geometrical tolerances for moulded parts – Part 3: General dimensional and geometrical tolerances and machine allowances for castings*
- BS EN ISO 8785, *Geometrical product specification (GPS) – Surface imperfections – Terms, definitions and parameters*
- BS EN ISO 8826-1, *Technical drawings – Roller bearings – Part 1: General simplified representation*
- BS EN ISO 8826-2, *Technical drawings – Roller bearings – Part 2: Detailed simplified representation*
- BS EN ISO 9222-1, *Technical drawings – Seals for dynamic application – Part 1: General simplified representation*
- BS EN ISO 9222-2, *Technical drawings – Seals for dynamic application – Part 2: Detailed simplified representation*
- BS EN ISO 10135, *Geometrical product specifications (GPS) – Drawing indications for moulded parts in technical product documentation (TPD)*
- BS EN ISO 10209, *Technical product documentation – Vocabulary – Terms relating to technical drawings, product definition and related documentation*
- BS EN ISO 11442, *Technical product documentation – Document management*
- BS EN ISO 12085, *Geometrical Product Specifications (GPS) – Surface texture: Profile method – Motif parameters*
- BS EN ISO 12180-1, *Geometrical product specifications (GPS) – Cylindricity – Part 1: Vocabulary and parameters of cylindrical form*

BS EN ISO 12180-2, *Geometrical product specifications (GPS) – Cylindricity – Part 2: Specification operators*

BS EN ISO 12181-1, *Geometrical product specifications (GPS) – Roundness – Part 1: Vocabulary and parameters of roundness*

BS EN ISO 12181-2, *Geometrical product specifications (GPS) – Roundness – Part 2: Specification operators*

BS EN ISO 12780-1, *Geometrical product specifications (GPS) – Straightness – Part 1: Vocabulary and parameters of straightness*

BS EN ISO 12780-2, *Geometrical product specifications (GPS) – Straightness – Part 2: Specification operators*

BS EN ISO 12781-1, *Geometrical product specifications (GPS) – Flatness – Part 1: Vocabulary and parameters of flatness*

BS EN ISO 12781-2, *Geometrical product specifications (GPS) – Flatness – Part 2: Specification operators*

BS EN ISO 13565-1, *Geometric Product Specifications (GPS) – Surface texture: Profile method – Surfaces having stratified functional properties – Part 1: Filtering and general measurement conditions*

BS EN ISO 13565-2, *Geometrical Product Specifications (GPS) – Surface texture: Profile method – Surfaces having stratified functional properties – Part 2: Height characterization using the linear material ration curve*

BS EN ISO 13565-3, *Geometrical product specifications (GPS) – Surface texture: Profile method – Surfaces having stratified functional properties – Part 3: Height characterization using the material probability curve*

BS EN ISO 13920, *Welding – General tolerances for welded constructions – Dimensions for lengths and angles – Shape and position*

BS EN ISO 14253-1, *Geometrical product specifications (GPS) – Inspection by measurement of workpieces and measuring equipment – Part 1: Decision rules for proving conformity or non-conformity with specifications<sup>12)</sup>*

BS EN ISO 14405-1, *Geometrical product specifications (GPS) – Dimensional tolerancing – Part 1: Linear sizes*

BS EN ISO 14405-2, *Geometrical product specifications (GPS) – Dimensional tolerancing – Part 2: Dimensions other than linear sizes*

BS EN ISO 14660-1, *Geometrical Product Specifications (GPS) – Geometrical features – Part 1: General terms and definitions*

BS EN ISO 14660-2, *Geometrical Product Specifications (GPS) – Geometrical features – Part 2: Extracted median line of a cylinder and a cone, extracted median surface, local size of an extracted feature<sup>13)</sup>*

BS EN ISO 15785, *Technical drawings – Symbolic presentation and indication of adhesive, fold and pressed joints*

BS EN ISO 16610-21, *Geometrical product specifications (GPS) – Filtration – Part 21: Linear profile filters: Gaussian filters*

BS EN ISO 26909, *Springs – Vocabulary*

BS EN ISO 80000-1, *Quantities and units – Part 1: General*

BS EN ISO 80000-2, *Quantities and units – Part 2: Mathematical signs and symbols to be used in the natural sciences and technology*

---

<sup>12)</sup> This standard also gives an informative reference to BS EN ISO 14253-1:2013.

<sup>13)</sup> Withdrawn.



- BS EN ISO 80000-3, *Quantities and units – Part 3: Space and time*
- BS EN ISO 80000-4, *Quantities and units – Part 4: Mechanics*
- BS EN ISO 80000-5, *Quantities and units – Part 5: Thermodynamics*
- BS EN ISO 80000-8, *Quantities and units – Part 8: Acoustics*
- BS EN ISO 80000-9, *Quantities and units – Part 9: Physical chemistry and molecular physics*
- BS EN ISO 80000-10, *Quantities and units – Part 10: Atomic and nuclear physics*
- BS EN ISO 80000-11, *Quantities and units – Part 11: Characteristic numbers*
- BS EN ISO 80000-12, *Quantities and units – Part 12: Solid state physics*
- BS EN ISO 81714-1, *Design of graphical symbols for use in the technical documentation of products – Part 1: Basic rules*
- BS ISO 128-22, *Technical drawings – General principles of presentation – Part 22: Basic conventions and applications for leader lines and reference lines*
- BS ISO 128-23, *Technical drawings – General principles of presentation – Part 23: Lines on construction drawings*
- BS ISO 128-24, *Technical drawings – General principles of presentation – Part 24: Lines on mechanical engineering drawings<sup>14)</sup>*
- BS ISO 128-25, *Technical drawings – General principles of presentation – Part 25: Lines on shipbuilding drawings*
- BS ISO 128-30, *Technical drawings – General principles of presentation – Part 30: Basic conventions for views*
- BS ISO 128-34, *Technical drawings – General principles of presentation – Part 34: Views on mechanical engineering drawings*
- BS ISO 128-40, *Technical drawings – General principles of presentation – Part 40: Basic conventions for cuts and sections*
- BS ISO 128-44, *Technical drawings – General principles of presentation – Part 44: Sections on mechanical engineering drawings*
- BS ISO 128-50, *Technical drawings – General principles of presentation – Part 50: Basic conventions for representing areas on cuts and sections*
- BS ISO 129-1, *Technical drawings – Indications of dimensions and tolerances – Part 1: General principles*
- BS ISO 1219-1, *Fluid power systems and components – Graphical symbols and circuit diagrams – Part 1: Graphical symbols for conventional use and data-processing applications*
- BS ISO 5456-4, *Technical drawings – Projection methods – Part 4: Central projection*
- BS ISO 7573, *Technical product documentation – Parts lists*
- BS ISO 10579, *Geometrical product specifications (GPS) – Dimensioning and tolerancing – Non-rigid parts*
- BS ISO 13715, *Technical drawings – Edges of unidentified shape – Vocabulary and indications*
- BS ISO 14617-1, *Graphical symbols for diagrams – Part 1: General information and indexes*
- BS ISO 14617-2, *Graphical symbols for diagrams – Part 2: Symbols having general application*

---

<sup>14)</sup> This standard also gives informative references to BS ISO 128-24:1999.

- BS ISO 14617-3, *Graphical symbols for diagrams – Part 3: Connections and related devices*
- BS ISO 14617-4, *Graphical symbols for diagrams – Part 4: Actuators and related devices*
- BS ISO 14617-5, *Graphical symbols for diagrams – Part 5: Measurement and control devices*
- BS ISO 14617-6, *Graphical symbols for diagrams – Part 6: Measurement and control functions*
- BS ISO 14617-7, *Graphical symbols for diagrams – Part 7: Basic mechanical components*
- BS ISO 14617-8, *Graphical symbols for diagrams – Part 8: Valves and dampers*
- BS ISO 14617-9, *Graphical symbols for diagrams – Part 9: Pumps, compressors and fans*
- BS ISO 14617-10, *Graphical symbols for diagrams – Part 10: Fluid power converters*
- BS ISO 14617-11, *Graphical symbols for diagrams – Part 11: Devices for heat transfer and heat engines*
- BS ISO 14617-12, *Graphical symbols for diagrams – Part 12: Devices for separating, purification and mixing*
- BS ISO 16016, *Technical product documentation – Protection notices for restricting the use of documents and products*
- BS ISO 16792, *Technical product documentation – Digital product definition data practices<sup>15)</sup>*
- BS ISO 80000-7, *Quantities and units – Part 7: Light*
- DD ISO/TS 16610-1, *Geometrical product specifications (GPS) – Filtration – Part 1: Overview and basic concepts*
- DD ISO/TS 16610-20, *Geometrical product specifications (GPS) – Filtration – Part 20: Linear profile filters: Basic concepts*
- DD ISO/TS 16610-22, *Geometrical product specifications (GPS) – Filtration – Part 22: Linear profile filters: Spline filters*
- DD ISO/TS 16610-29, *Geometrical product specifications (GPS) – Filtration – Part 29: Linear profile filters: Spline wavelets*
- DD ISO/TS 16610-40, *Geometrical product specifications (GPS) – Filtration – Part 40: Morphological profile filters: Basic concepts*
- DD ISO/TS 16610-41, *Geometrical product specifications (GPS) – Filtration – Part 41: Morphological profile filters: Disk and horizontal line-segment filters*
- DD ISO/TS 16610-49, *Geometrical product specifications (GPS) – Filtration – Part 49: Morphological profile filters: Scale space techniques*
- ISO/IEC Guide 98-3, *Guide to the expression of uncertainty in measurement (GUM)*
- ISO/IEC Guide 99, *International vocabulary of metrology – Basic and general concepts and associated terms (VIM)*
- PD CEN ISO/TS 8062-2, *Geometrical Product Specifications (GPS) – Dimensional and geometrical tolerances for moulded parts – Part 2: Rules*

---

<sup>15)</sup> This standard also gives an informative reference to BS ISO 16792:2015.

Annex B  
(informative)

## Bibliography

### Standards publications

For dated references, only the edition cited applies. For undated references, the latest edition of the referenced document (including any amendments) applies.

BS 308, *Engineering drawing practice*<sup>16)</sup>

BS 1192 (all parts), *Construction drawing practice*

BS 3643-1, *ISO metric screw threads – Part 1: Principles and basic data*

BS 3643-2, *ISO metric screw threads – Part 2: Specification for selected limits of size*

BS 4235-1, *Specification for metric keys and keyways – Part 1: Parallel and taper keys*

BS 4235-2, *Specification for metric keys and keyways – Part 2: Woodruff keys and keyways*

BS 4827, *Specification for ISO miniature screw threads – Metric series*

BS 8887 (all parts), *Design for manufacture, assembly, disassembly and end-of-life processing (MADE)*

BS 8889, *Technical product verification – Inspection of size, form and surface texture in relation to function – Specification*<sup>17)</sup>

BS EN 10243-1, *Steel die forgings – Tolerances on dimensions – Part 1: Drop and vertical press forgings*

BS EN 22768-1, *General tolerances – Part 1: Tolerances for linear and angular dimensions without individual tolerance indications*

BS EN 22768-2, *General tolerances – Part 2: Geometrical tolerances for features without individual tolerance indications*

BS EN ISO 216, *Writing paper and certain classes of printed matter – Trimmed sizes – A and B series, and indication of machine direction*

BS EN ISO 5455, *Technical drawings – Scales*

BS EN ISO 5456-1, *Technical drawing – Projection methods – Part 1: Synopsis*

BS EN ISO 17450-1, *Geometrical product specification (GPS) – General concepts – Part 1: Model for geometrical specification and verification*

BS ISO 129-2, *Technical product documentation – Indication of dimensions and tolerances – Part 2: Dimensioning of mechanical engineering drawing*<sup>17)</sup>

BS ISO 129-4, *Technical product documentation (TPD) – Indication of dimensions and tolerances – Part 4: Dimensioning of shipbuilding drawings*

BS ISO 261, *ISO general purpose metric screw threads – General plan*

BS ISO 262, *ISO general purpose metric screw threads – Selected sizes for screws, bolts and nuts*

BS ISO 965-1, *ISO general purpose metric screw threads – Tolerances – Part 1: Principles and basic data*

BS ISO 15786, *Technical drawings – Simplified representation and dimensioning of holes*

BS ISO 29845, *Technical product documentation — Document types*

<sup>16)</sup> Withdrawn.

<sup>17)</sup> In development.



DIN 7167, *Relationship between tolerances of size, form, and parallelism; envelope requirement without individual indication on the drawing*<sup>18)</sup>

ISO/TR 14638, *Geometrical product specification (GPS) – Masterplan*<sup>18)</sup>

PD 68888, *Objectives and learning outcomes for BS 8888 training*

### Other publications

[1] AMERICAN SOCIETY OF MECHANICAL ENGINEERS (ASME). *Dimensioning and tolerancing (Y14.5)*. New York: ASME, 2009.

Annex C  
(informative)

## Associations

### C.1 Association operations

The association operation is the method used to “fit” the ideal geometry to the non-ideal feature. Traditionally, when this was achieved using a mechanical device such as a surface table, angle plate or chuck, there was no need to define an association operation, as there was only one possibility.

Advances in metrological equipment have meant that devices such as coordinate measuring machines (CMMs), articulated arms and scanners of various kinds can offer a multiplicity of different association operations. Some of these are used when defining datums, while others are used when evaluating tolerances; some of these work better with some kinds of geometry, and others with different kinds of geometry. The term “best fit” is frequently used, often very loosely, and can refer to any of a number of association operations, including the following:

- a) minimax (also known as the  $L_{\infty \text{ norm}}$ ): the associated feature is arranged to minimize the maximum distance between the associated feature and the datum feature;
- b) minimum circumscribed (also known as “Chebyshev”): the associated feature is the smallest ideal feature which fully envelops the datum feature;
- c) maximum inscribed (also known as “Chebyshev”): the associated feature is the largest ideal feature which can be fully enveloped by the datum feature;
- d) least squares (also known as “Gaussian” or  $L_2 \text{ norm}$ ): the associated feature is an ideal feature fitted to the datum feature using the total least squares algorithm.

*NOTE* The name is usually taken from the mathematical algorithm on which the operation is based.

In addition, the following factors can affect the association.

#### 1) Location and orientation constraints

If the association is being performed in the definition of a secondary or tertiary datum, it will include additional orientation or location constraints to ensure that the correct relationship with the preceding datums is maintained.

#### 2) Material constraints

In some cases, the associated feature can be established entirely outside the material of the workpiece, or entirely inside the material of the workpiece.

<sup>18)</sup> Withdrawn.

### 3) Intrinsic constraints

Some datum features can be defined either with a toleranced dimension, or with a theoretically exact dimension. In some cases, the associated feature could be defined with either a toleranced dimension or a theoretically exact dimension.

## C.2 Default association operations

When defining datums, there are default association operations which are to be used, unless otherwise stated (see Table C.1).

Table C.1 Default association operations used when defining datums

Datum feature	Internal or external	Default association operation	Default material constraint	Intrinsic characteristic	Default intrinsic constraint	Situation feature
Plane	–	Minimax	Outside the material	–	–	Plane
Two parallel opposed planes	External (flange)	Minimum circumscribed <sup>A)</sup>	Outside the material	Width (distance between the two parallel planes)	Variable	Plane
	Internal (slot)	Maximum inscribed <sup>A)</sup>				
Cylinder	External (shaft)	Minimum circumscribed <sup>A)</sup>	Outside the material	Diameter	variable	Line (axis)
	Internal (hole)	Maximum inscribed <sup>A)</sup>				
Sphere	External (ball)	Minimum circumscribed <sup>A)</sup>	Outside the material	Diameter	Variable	Point
	Internal (socket)	Maximum inscribed <sup>A)</sup>				
Cone	External	Minimax	Outside the material	Angle	Fixed	Line and point
	Internal	Minimax				
Wedge	External	Minimax	Outside the material	Angle	Fixed	Plane and line
	Internal	Minimax				
Prismatic	–	Minimax	Outside the material	–	–	Plane and line
Complex	–	Minimax	Outside the material	–	–	Plane, line and point

<sup>A)</sup> In cases where the linear size (of the feature or size) is considered variable, the result of the association can lead to several solutions with the same datum feature ("unstable association"). In this case, the following alternative association criterion are used: minimize the maximum distance normal to the associated feature between the associated feature and the datum feature or between the two associated features and the two datum features (in the case of two parallel planes).

## C.3 Non-default association operations

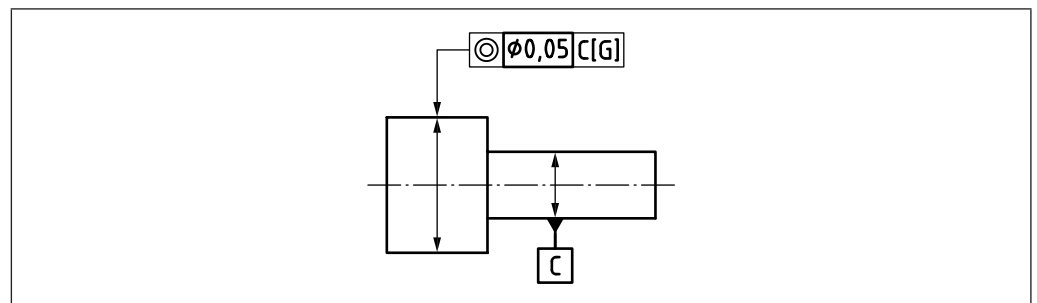
It is also possible to use alternative association operations. These can be invoked by using the following modifiers next to the datum reference in a tolerance frame. As these are yet to be standardized in a published ISO standard, it is imperative that the use of any of these modifiers is fully explained with a key or a description on the specification.

Non-default association algorithms are invoked with the following symbols:

Algorithm	Symbol
Least squares (Gaussian)	G
Minimax	C
Minimum circumscribed (Chebyshev)	N
Maximum inscribed (Chebyshev)	X
Minimizing p-norm distance	$L_1$ , $L_2$ or $L_\infty$

An example of an individual specification operator for a datum association is given in Figure C.1.

Figure C.1 Example of individual specification operator for a datum association



Non-default material constraints can be invoked with the following symbols:

Material constraint	Symbol
Outside material	O
Inside material	I
No material constraint	M
Shifted tangent outside material	+
Shifted tangent inside material	-

Non-default intrinsic constraints can be invoked with the following symbols:

Intrinsic constraint	Symbol
Size fixed	[SF]
Size variable	[SV]

Annex D  
(normative)

## Document security – Enhanced

### D.1 Enhanced security

Where requirements for enhanced security are known to exist, the procedures identified in this annex shall be applied in addition to those specified in 10.2.4.

### D.2 Identification of security classification

Any required security classification and/or caveat shall be inserted in the TPS immediately after classified information is incorporated.

Each sheet shall be classified according to its content.

The security classification shall always appear at the top and bottom of A4 sheets and at the top left and bottom right-hand corners of sheets larger than A4.

The security classification shall either be:

- a) larger than the largest text used in the TPS; or
- b) bolder and the same size as the largest text used in the TPS.

### D.3 Marking for enhanced security

Technical product document sets, prepared in accordance with the requirements of D.1 and D.2, shall be identified by the addition of the suffix "/D" to the number of this standard, i.e. "BS 8888/D", in a prominent location.

## Annex E (informative) Implementation in CAD

### E.1 General

Most CAD software:

- is limited in its ability to implement the full requirements of ISO standards;
- does not correctly distinguish between datums and datum features; and
- is not currently capable of dealing with datums consisting of more than one situation feature.

To implement these concepts in CAD, it might be necessary to deviate from the rules and methods defined in BS 8888 and ISO standards.

The following does not replace or override the requirements of BS 8888 and ISO standards; they are simply offered to assist with the practical implementation of some of the datum requirements described in this section.

### E.2 Implementation according to BS 8888 and BS EN ISO 5459

In Figure E.1:

- a) datum A is a single datum;
- b) the datum feature is a complex surface;
- c) datum A consists of a plane, line and point; and
- d) if a position tolerance is applied to a hole in the part, a reference to datum A is sufficient to control all six degrees of freedom for the tolerance zone.

### E.3 Implementation according to most CAD software

Where necessary, each situation feature can be treated as a separate datum. For example, in Figure E.2:

- a) the datum system consists of three mutually perpendicular planes, each of which has a separate datum name;
- b) the datum feature is the complex surface.

Because the CAD system has been used to allocate datum names individually to the three planes, it is not usually possible to use a datum feature identifier on the complex surface, and it needs to be labelled with a note instead.

It might be necessary to highlight the datum feature surfaces in some way to clearly distinguish them.

It might also be necessary to clarify the “best fit” method to be used with a note.

EXAMPLE:

DATUM SYSTEM  $\boxed{A|B|C}$  IS DEFINED USING LEAST SQUARES BEST FIT TO DATUM SURFACE INDICATED.

Figure E.1 Implementation according to BS 8888 and BS EN ISO 5459

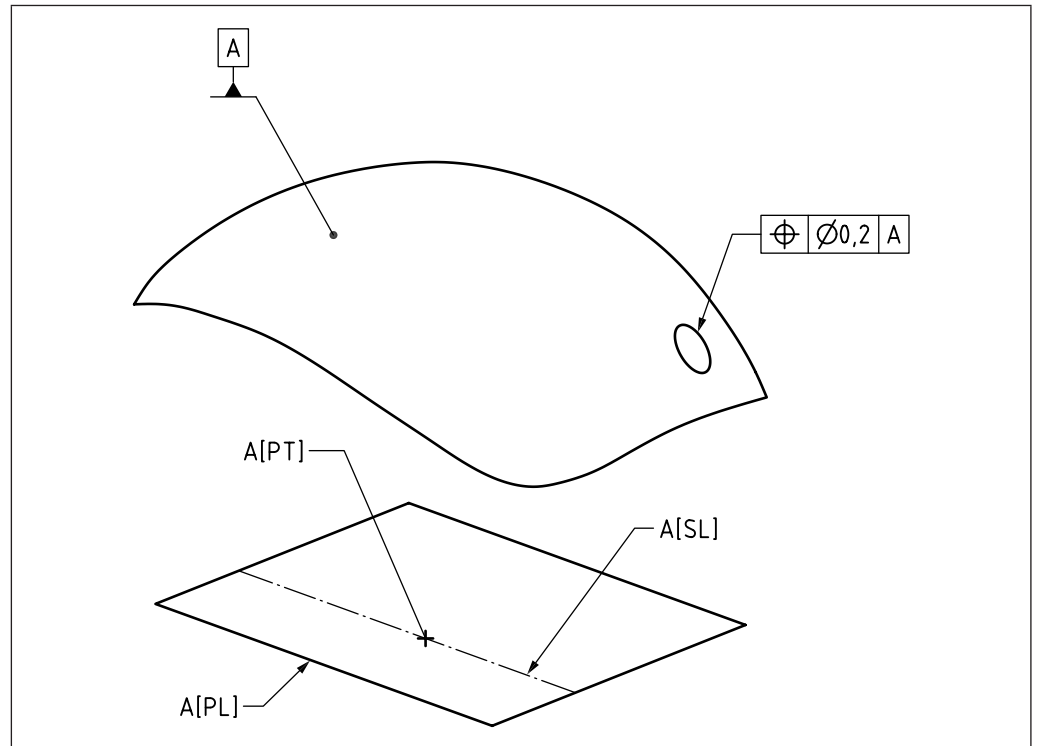
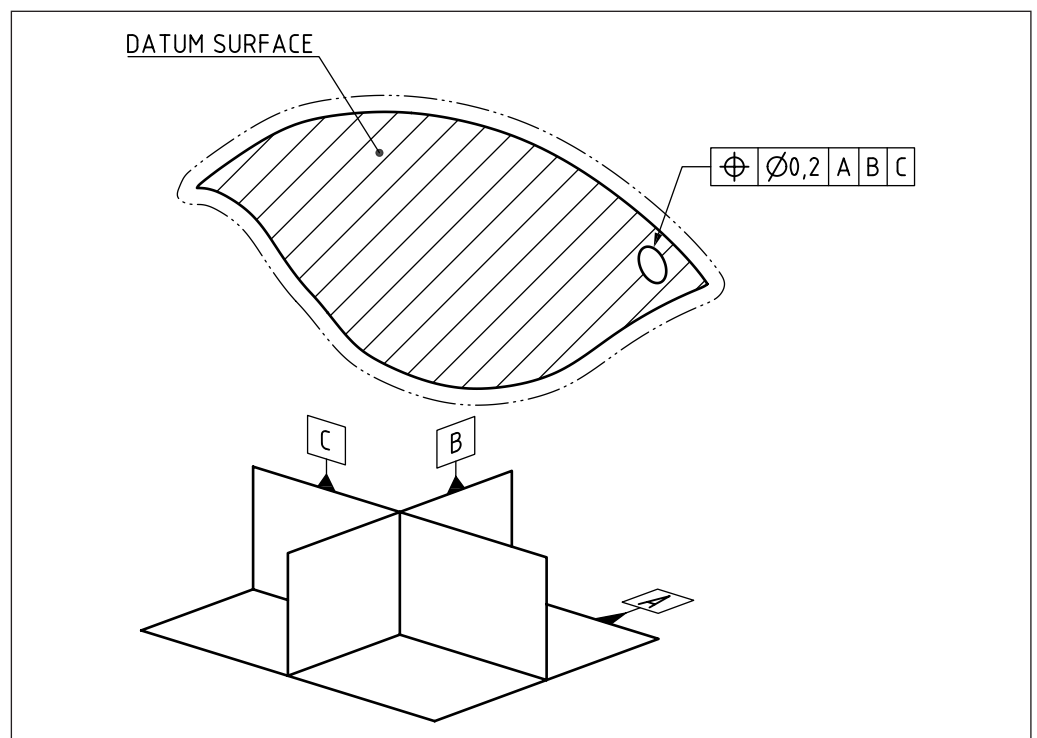


Figure E.2 Implementation according to most CAD software



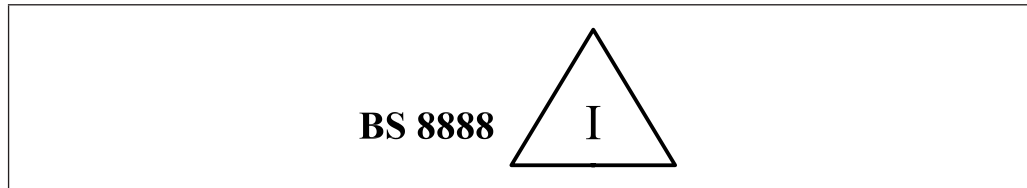
Annex F  
(informative)

## Tolerancing system: Former practice

It was former practice to mark a TPS with the indication "BS 8888", supplemented by the letter "I" contained within an equilateral triangle (see Figure F.1) or the letter "D" contained within an equilateral triangle (see Figure F.2).

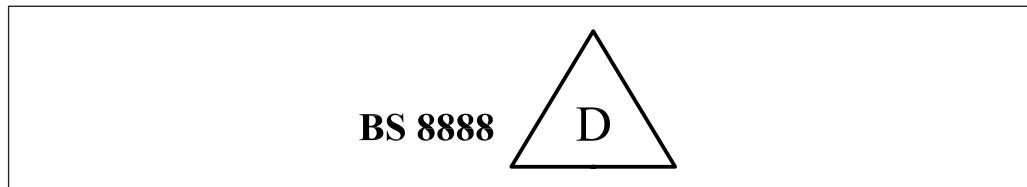
The triangle "I" symbol (see Figure F.1) was taken to indicate that the principle of independency was to be used to govern the interpretation of size and form requirements. While this had the same meaning as "TOLERANCING ISO 8015", its meaning might not be apparent to an interpreter who was familiar with ISO standards, but not BS 8888, so its use is no longer recommended.

Figure F.1 **BS 8888 independency system symbol**



The triangle "D" symbol (see Figure F.2) was taken to indicate that the principle of dependency was to be used to govern the interpretation of size and form requirements. While this was included to maintain consistency with earlier versions of BS 8888 and BS 308, the interpretation of the principle of dependency as a general requirement is not fully defined within the ISO system, so there might be ambiguities in its interpretation. In view of such possible ambiguities, and the fact that the symbol might not be understood by interpreters who were familiar with the ISO system but not BS 8888, the use of this symbol is no longer recommended.

Figure F.2 **BS 8888 dependency system symbol**



**Annex G Selected ISO fits: Hole and shaft basis**  
(informative)

Table G.1 Selected ISO fits: Hole basis (1 of 2)

Nominal sizes		Clearance fits										Transition fits						Interference fits					
		Tolerances		Tolerances		Tolerances		Tolerances		Tolerances		Tolerances		Tolerances		Tolerances		Tolerances		Nominal sizes			
Over	To	H11	c11	H9	d10	H9	e9	H8	f7	H7	g6	H7	h6	H7	k6	H7	n6	H7	p6	H7	s6	Over	To
mm	mm	0,001 mm		0,001 mm		0,001 mm		0,001 mm		0,001 mm		0,001 mm		0,001 mm		0,001 mm		0,001 mm		0,001 mm		mm	mm
-	3	+60	-60	+25	-20	+25	-14	+14	-6	+10	-2	0	0	-6	+6	+10	+10	+10	+12	+10	+20	-	3
		0	-120	0	-60	0	-39	0	-16	0	0	0	0	0	0	0	+4	0	+6	0	+14		
3	6	+75	-70	+30	-30	+30	-20	+18	-10	+12	-4	0	0	-4	+9	+12	+16	+12	+20	+12	+27	3	6
		0	-145	0	-78	0	-50	0	-22	0	-12	0	-8	+1	0	+18	+18	0	+12	0	+19		
6	10	+90	-80	+36	-40	+36	-25	+22	-13	+15	-5	0	0	-9	+10	+15	+19	+15	+24	+15	+32	6	10
		0	-170	0	-98	0	-61	0	-28	0	-14	0	0	0	0	0	+10	0	+15	0	+23		
10	18	+110	-95	+43	-50	+43	-32	+27	-16	+18	-6	0	0	-17	+12	+18	+23	+18	+29	+18	+39	10	18
		0	-205	0	-120	0	-75	0	-34	0	-17	0	-11	0	+1	0	+12	0	+18	0	+28		
18	30	+130	-110	+52	-65	+52	-40	+33	-20	+21	-7	0	0	-20	+15	+21	+28	+21	+35	+21	+48	18	30
		0	-240	0	-149	0	-92	0	-41	0	-20	0	-13	0	+2	0	+15	0	+22	0	+35		
30	40	+160	-120	+62	-80	+62	-50	+39	-25	+25	-9	0	0	-25	+18	+25	+33	+25	+42	+25	+59	30	40
		0	-280	0	-180	0	-112	0	-50	0	-25	0	-16	0	+2	0	+17	0	+26	0	+43		
40	50	+190	-140	+74	-100	+74	-60	+46	-30	+30	-10	0	0	-19	+21	+30	+39	+30	+51	+30	+72	50	65
		0	-330	0	-220	0	-134	0	-60	0	-29	0	0	0	+2	0	+20	0	+32	0	+53		
65	80	+220	-170	+87	-120	+87	-72	+54	-36	+35	-12	0	0	-22	+25	+35	+45	+35	+59	+35	+71	65	80
		0	-340	0	-260	0	-159	0	-71	0	-34	0	0	0	+3	0	+23	0	+37	0	+59		
80	100	+250	-180	+100	-145	+100	-85	+63	-43	+40	-14	0	0	-25	+28	+40	+52	+40	+68	+40	+101	80	100
		0	-400	0	-305	0	-185	0	-83	0	-39	0	0	0	+3	0	+27	0	+43	0	+101		
100	120	+290	-230	+115	-170	+115	-100	+72	-50	+46	-15	0	0	-29	+33	+46	+60	+46	+79	+46	+117	100	120
		0	-480	0	-355	0	-215	0	-96	0	-44	0	0	0	+4	0	+31	0	+50	0	+117		
120	140	+290	-240	+115	-170	+115	-100	+72	-50	+46	-15	0	0	-29	+33	+46	+60	+46	+79	+46	+117	120	140
		0	-530	0	-355	0	-215	0	-96	0	-44	0	0	0	+4	0	+31	0	+50	0	+117		
140	160	+290	-210	+115	-170	+115	-100	+72	-50	+46	-15	0	0	-29	+33	+46	+60	+46	+79	+46	+117	140	160
		0	-460	0	-305	0	-185	0	-83	0	-39	0	0	0	+3	0	+27	0	+43	0	+117		
160	180	+290	-230	+115	-170	+115	-100	+72	-50	+46	-15	0	0	-29	+33	+46	+60	+46	+79	+46	+117	160	180
		0	-480	0	-355	0	-215	0	-96	0	-44	0	0	0	+4	0	+31	0	+50	0	+117		
180	200	+290	-240	+115	-170	+115	-100	+72	-50	+46	-15	0	0	-29	+33	+46	+60	+46	+79	+46	+117	180	200
		0	-530	0	-355	0	-215	0	-96	0	-44	0	0	0	+4	0	+31	0	+50	0	+117		
200	225	+290	-260	+115	-170	+115	-100	+72	-50	+46	-15	0	0	-29	+33	+46	+60	+46	+79	+46	+117	200	225
		0	-550	0	-355	0	-215	0	-96	0	-44	0	0	0	+4	0	+31	0	+50	0	+117		
225	250	+290	-280	+115	-170	+115	-100	+72	-50	+46	-15	0	0	-29	+33	+46	+60	+46	+79	+46	+117	225	250
		0	-570	0	-355	0	-215	0	-96	0	-44	0	0	0	+4	0	+31	0	+50	0	+117		
250																							

Table G.1 Selected ISO fits: Hole basis (2 of 2)

Nominal sizes		Clearance fits											Transition fits						Interference fits					
		Tolerances		Tolerances		Tolerances		Tolerances		Tolerances		Tolerances		Tolerances		Tolerances		Tolerances		Tolerances		Tolerances		Nominal sizes
Over	To	H11	C11	H9	d10	H9	e9	H8	f7	H7	g6	H7	h6	H7	k6	H7	n6	H7	p6	H7	s6	Over	To	
mm	mm	0,001 mm		0,001 mm		0,001 mm		0,001 mm		0,001 mm		0,001 mm		0,001 mm		0,001 mm		0,001 mm		0,001 mm		mm	mm	
250	280	+320	-300	+130	-190	+130	-110	+81	-56	+52	-17	+52	0	+52	+36	+52	+66	+52	+88	+190	+52	250	280	
		0	-620	0	-400	0	-240	0	-108	0	-49	0	-32	0	+4	0	+34	0	+56	0	+158	280	315	
			-650																		+170			
315	355	+360	-360	+140	-210	+140	-125	+89	-62	+57	-18	+57	0	+57	+40	+57	+73	+57	+98	+226	+57	315	355	
		0	-720	0	-440	0	-265	0	-119	0	-54	0	-36	0	+4	0	+37	0	+62	+190	0			
			-760																		+244			
																					+208			
400	450	+400	-440	+155	-230	+155	-135	+97	-68	+63	-20	+63	0	+63	+45	+63	+80	+63	+108	+272	+63	400	450	
		0	-840	0	-480	0	-290	0	-131	0	-60	0	-40	0	+5	0	+40	0	+68	+232	0			
			-880																		+292			
																					+252			

Table G.2 Selected ISO fits: Shaft basis (1 of 2)

Nominal sizes		Clearance fits											Transition fits						Interference fits					
		Tolerances		Tolerances		Tolerances		Tolerances		Tolerances		Tolerances		Tolerances		Tolerances		Tolerances		Tolerances		Tolerances		Nominal sizes
Over	To	h11	C11	h9	D10	h9	E9	h7	F8	h6	G7	h6	H7	h6	K7	h6	N7	h6	P7	h6	S7	Over	To	
mm	mm	0,001 mm		0,001 mm		0,001 mm		0,001 mm		0,001 mm		0,001 mm		0,001 mm		0,001 mm		0,001 mm		0,001 mm		mm	mm	
-	3	0	+120	0	+60	0	+39	0	+20	0	+12	0	+10	0	0	0	-4	0	-6	0	-14	-	3	
		-60	+60	-25	+20	-25	+14	-10	+6	-6	+2	-6	0	-6	-10	-6	-14	-6	-16	-6	-24			
3	6	0	+145	0	+78	0	+50	0	+28	0	+16	0	+12	0	+3	0	-4	0	-8	0	-15	3	6	
		-75	+70	-30	+30	-30	+20	-12	+10	-8	+4	-8	0	-8	-9	-8	-16	-8	-20	-8	-27			
6	10	0	+170	0	+98	0	+61	0	+35	0	+20	0	+15	0	+5	0	-4	0	-9	0	-17	6	10	
		-90	+80	-36	+40	-36	+25	-15	+13	-9	+5	-9	0	-9	-10	-9	-19	-9	-24	-9	-32			
10	18	0	+205	0	+120	0	+75	0	+43	0	+24	0	+18	0	+6	0	-5	0	-11	0	-21	10	18	
		-110	+95	-43	+50	-43	+32	-18	+16	-11	+6	-11	0	-11	-12	-11	-23	-11	-29	-11	-39			
18	30	0	+240	0	+149	0	+92	0	+53	0	+28	0	+21	0	+6	0	-7	0	-14	0	-27	18	30	
		-130	+110	-52	+65	-52	+40	-21	+20	-13	+7	-13	0	-13	-15	-13	-28	-13	-35	-13	-48			
30	40	0	+280	0	+180	0	+112	0	+64	0	+34	0	+25	0	+7	0	-8	0	-17	0	-34	30	40	
		-160	+290	-62	+80	-62	+50	-25	+25	-16	+9	-16	0	-16	-18	-16	-33	-16	-42	-16	-59			
			+130																			40	50	



Table G.2 Selected ISO fits: Shaft basis (2 of 2)

Nominal sizes		Clearance fits											Transition fits						Interference fits				
		Tolerances		Tolerances		Tolerances		Tolerances		Tolerances		Tolerances		Tolerances		Tolerances		Tolerances		Tolerances		Nominal sizes	
Over	To	h11	C11	h9	D10	h9	E9	h7	F8	h6	G7	h6	H7	h6	K7	h6	N7	h6	P7	h6	S7	Over	To
mm	mm	0,001 mm	0,001 mm	0,001 mm	0,001 mm	0,001 mm	0,001 mm	0,001 mm	0,001 mm	0,001 mm	0,001 mm	0,001 mm	0,001 mm	0,001 mm	0,001 mm	0,001 mm	0,001 mm	0,001 mm	0,001 mm	0,001 mm	0,001 mm	mm	mm
50	65	0	+330 +140	0	+220 +100	0	+134 +60	0	+76 +30	0	+40 +10	0	+30 0	0	+9 -21	0	-9 -39	0	-21 -51	0	-42 -72	50	65
65	80	-190	+340 +150	-74	+100	-74	+60	-30	+30	-19	+10	-19	0	0	-19	-19	-39	-19	-51	-19	-48 -78	65	80
80	100	0	+390 +170	0	+260 +120	0	+159 +72	0	+90 +36	0	+47 +12	0	+35 0	0	+10 -25	0	-10 -45	0	-24 -59	0	-58 -93	80	100
100	120	-220	+400 +180	-87	+120	-87	+72	-35	+36	-22	+12	-22	0	0	-22	-22	-45	-22	-59	-22	-66 -101	100	120
120	140	0	+450 +200	0	+305 +145	0	+185 +85	0	+106 +43	0	+54 +14	0	+40 0	0	+12 -28	0	-12 -52	0	-28 -68	0	-77 -117	120	140
140	160	0	+460 +210	0	+305 +145	0	+185 +85	0	+106 +43	0	+54 +14	0	+40 0	0	+12 -28	0	-12 -52	0	-28 -68	0	-85 -125	140	160
160	180	-250	+480 +230	-100	+145	-100	+85	-40	+43	-25	+14	-25	0	0	-25	-25	-52	-25	-68	-25	-93 -133	160	180
180	200	0	+530 +240	0	+355 +170	0	+215 +100	0	+122 +50	0	+61 +15	0	+46 0	0	+13 -33	0	-14 -60	0	-33 -79	0	-105 -151	180	200
200	225	0	+550 +260	0	+355 +170	0	+215 +100	0	+122 +50	0	+61 +15	0	+46 0	0	+13 -33	0	-14 -60	0	-33 -79	0	-113 -159	200	225
225	250	-290	+570 +280	-115	+170	-115	+100	-46	+50	-29	+15	-29	0	0	-29	-29	-60	-29	-79	-29	-123 -169	225	250
250	280	0	+620 +300	0	+400 +190	0	+240 +110	0	+137 +56	0	+62 +17	0	+52 0	0	+16 -36	0	-14 -66	0	-36 -88	0	-138 -190	250	280
280	315	-320	+650 +330	-130	+190	-130	+110	-52	+56	-32	+17	-32	0	0	-32	-32	-66	-32	-88	-32	-150 -202	280	315
315	355	0	+720 +360	0	+440 +210	0	+265 +125	0	+151 +62	0	+75 +18	0	+57 0	0	+17 -40	0	-16 -73	0	-41 -98	0	-169 -226	315	355
355	400	-360	+760 +400	-140	+210	-140	+125	-57	+62	-36	+18	-36	0	0	-36	-36	-73	-36	-98	-36	-187 -244	355	400
400	450	0	+840 +440	0	+480 +230	0	+290 +135	0	+165 +68	0	+83 +20	0	+63 0	0	+18 -45	0	-17 -80	0	-45 -108	0	-209 -272	400	450
450	500	-400	+880 +480	-155	+230	-155	+135	-63	+68	-40	+20	-40	0	0	-40	-40	-80	-40	-108	-40	-229 -292	450	500

Annex H  
(informative)

## Filtration

### H.1 Introduction

Whenever a measurement is taken of a manufactured surface, the measurement data are always incomplete. For instance, some information regarding the surface is lost due to the resolution of the measurement process.

The data representing the manufactured surface are thus filtered by the measurement process. The manner in which the measurement process filters the measurement data can be controlled, for instance, by defining the diameter of a probe tip, by defining the point extraction strategy, or by defining the extent over which a trace is taken.

In addition to the filtration that is an inevitable consequence of the measurement process, additional filters can be imposed on the measurement data in order to highlight particular properties of a surface, or simply to reduce the quantity of measurement data to a manageable level.

Filtration of measurement data is unavoidable, but traditionally mechanical specifications have tended to ignore this. This has meant that the metrologist checking a specification has considerable scope to sway a measurement towards conformity (or nonconformity), irrespective of the actual properties of the workpiece, by choosing a form of filtration that ensures a convenient outcome. It also means that the metrologist might inadvertently select measurement processes that fail to detect manufacturing deviations on which the designer wished to place a limit.

### H.2 Defining filters

The definition of the filter should be the responsibility of the designer or specifier, as it has a direct influence on the way in which conformity and nonconformity of a workpiece is determined, and thus on the properties and performance of the finished product. This, however, requires a major change in the working practices of designers and specifiers in all areas of industry. BS 8888 and ISO standards do not, currently, impose any requirement on specifiers to define filtration properties, but they are now introducing the means to define these requirements.

The practice of defining filtration properties is already well established with surface texture definitions. The possibility of defining filter properties for geometrical tolerances of form, such as flatness and roundness, has been around since 2003, when the ISO form standards ISO 12180, ISO 12181, ISO 12780 and ISO 12781 first appeared as ISO Technical Specifications [these later became full ISO standards (implemented as European standards), and ISO plans to merge them into the next revision of ISO 1101]. ISO standards are now going to extend these capabilities to enable filtration requirements to be defined for any geometrical tolerance requirement.

The definition of filtration requirements for a tolerance is optional, but if they are not defined, the specification and measurement uncertainties can be greatly increased.

### H.3 Filters and nesting indices

When a filter is defined, there are two components: one is the type of filter, and the other is the parameter (or parameters) required for that type of filter.

An analogy sometimes used is that of a sieve, used to filter out objects larger than the holes in the sieve. The type of filter is the type of sieve; some have round

holes, some have square holes, and some may have slots arranged in various ways. The parameters associated with the filter define the properties of the aperture (such as the size of the hole or the width of the slot).

The parameter associated with a filter (in the analogy, the size of the aperture in the sieve) is referred to as the “nesting index”. As the nesting index approaches zero, the size of the aperture approaches zero and nothing can get through, so all data representing the surface are captured and nothing is filtered out.

When a filter is applied to an “open” feature, a feature which terminates at an edge or a point, such as a line element or plane, the nesting index is defined in millimetres.

When a filter is applied to a “closed” surface, a feature which is continuous, such as a circular line element or a cylinder in the circumferential direction, the nesting index is defined in “undulations per revolution” (UPR).

## H.4 Different types of filter

Filters are classified in a number of different ways, the most fundamental of which are profile and areal filters:

**a) Profile filters**

Profile filters are applied to a two-dimensional profile.

**b) Areal filters**

Areal filters are applied to three-dimensional areas.

Another way in which filters are classified is as long-wave pass, short-wave pass and band pass:

**1) Long-wave pass filters**

Long-wave pass filters allow longer wavelength properties to pass through and filter out the shorter wavelength properties. This is probably the most common type of filter.

**2) Short-wave pass filters**

Short-wave pass filters allow shorter wavelength properties to pass through and filter out the longer wavelength properties.

**3) Band pass filters**

Band pass filters have longer and shorter wavelength limits, allowing a specified range of wavelengths through.





# British Standards Institution (BSI)

BSI is the national body responsible for preparing British Standards and other standards-related publications, information and services.

BSI is incorporated by Royal Charter. British Standards and other standardization products are published by BSI Standards Limited.

## About us

We bring together business, industry, government, consumers, innovators and others to shape their combined experience and expertise into standards-based solutions.

The knowledge embodied in our standards has been carefully assembled in a dependable format and refined through our open consultation process. Organizations of all sizes and across all sectors choose standards to help them achieve their goals.

## Information on standards

We can provide you with the knowledge that your organization needs to succeed. Find out more about British Standards by visiting our website at [bsigroup.com/standards](http://bsigroup.com/standards) or contacting our Customer Services team or Knowledge Centre.

## Buying standards

You can buy and download PDF versions of BSI publications, including British and adopted European and international standards, through our website at [bsigroup.com/shop](http://bsigroup.com/shop), where hard copies can also be purchased.

If you need international and foreign standards from other Standards Development Organizations, hard copies can be ordered from our Customer Services team.

## Copyright in BSI publications

All the content in BSI publications, including British Standards, is the property of and copyrighted by BSI or some person or entity that owns copyright in the information used (such as the international standardization bodies) and has formally licensed such information to BSI for commercial publication and use.

Save for the provisions below, you may not transfer, share or disseminate any portion of the standard to any other person. You may not adapt, distribute, commercially exploit, or publicly display the standard or any portion thereof in any manner whatsoever without BSI's prior written consent.

## Storing and using standards

Standards purchased in soft copy format:

- A British Standard purchased in soft copy format is licensed to a sole named user for personal or internal company use only.
- The standard may be stored on more than 1 device provided that it is accessible by the sole named user only and that only 1 copy is accessed at any one time.
- A single paper copy may be printed for personal or internal company use only.

Standards purchased in hard copy format:

- A British Standard purchased in hard copy format is for personal or internal company use only.
- It may not be further reproduced – in any format – to create an additional copy. This includes scanning of the document.

If you need more than 1 copy of the document, or if you wish to share the document on an internal network, you can save money by choosing a subscription product (see 'Subscriptions').

## Reproducing extracts

For permission to reproduce content from BSI publications contact the BSI Copyright & Licensing team.

## Subscriptions

Our range of subscription services are designed to make using standards easier for you. For further information on our subscription products go to [bsigroup.com/subscriptions](http://bsigroup.com/subscriptions).

With **British Standards Online (BSOL)** you'll have instant access to over 55,000 British and adopted European and international standards from your desktop. It's available 24/7 and is refreshed daily so you'll always be up to date.

You can keep in touch with standards developments and receive substantial discounts on the purchase price of standards, both in single copy and subscription format, by becoming a **BSI Subscribing Member**.

**PLUS** is an updating service exclusive to BSI Subscribing Members. You will automatically receive the latest hard copy of your standards when they're revised or replaced.

To find out more about becoming a BSI Subscribing Member and the benefits of membership, please visit [bsigroup.com/shop](http://bsigroup.com/shop).

With a **Multi-User Network Licence (MUNL)** you are able to host standards publications on your intranet. Licences can cover as few or as many users as you wish. With updates supplied as soon as they're available, you can be sure your documentation is current. For further information, email [subscriptions@bsigroup.com](mailto:subscriptions@bsigroup.com).

## Revisions

Our British Standards and other publications are updated by amendment or revision.

We continually improve the quality of our products and services to benefit your business. If you find an inaccuracy or ambiguity within a British Standard or other BSI publication please inform the Knowledge Centre.

## Useful Contacts

### Customer Services

**Tel:** +44 345 086 9001

**Email (orders):** [orders@bsigroup.com](mailto:orders@bsigroup.com)

**Email (enquiries):** [cservices@bsigroup.com](mailto:cservices@bsigroup.com)

### Subscriptions

**Tel:** +44 345 086 9001

**Email:** [subscriptions@bsigroup.com](mailto:subscriptions@bsigroup.com)

### Knowledge Centre

**Tel:** +44 20 8996 7004

**Email:** [knowledgecentre@bsigroup.com](mailto:knowledgecentre@bsigroup.com)

### Copyright & Licensing

**Tel:** +44 20 8996 7070

**Email:** [copyright@bsigroup.com](mailto:copyright@bsigroup.com)

### BSI Group Headquarters

389 Chiswick High Road London W4 4AL UK