

**BS 8541-2:2011**

*Incorporating Corrigendum No. 1*



BSI Standards Publication

# **Library objects for architecture, engineering and construction –**

Part 2: Recommended 2D symbols of  
building elements for use in  
building information modelling

NO COPYING WITHOUT BSI PERMISSION EXCEPT AS PERMITTED BY COPYRIGHT LAW

*raising standards worldwide™*



**Publishing and copyright information**

The BSI copyright notice displayed in this document indicates when the document was last issued.

© BSI 2011

ISBN 978 0 580 77126 2

ICS 01.100.30

The following BSI references relate to the work on this standard:

Committee reference B/555

Draft for comment 11/30218810 DC

**Publication history**

First published September 2011

**Amendments issued since publication**

<b>Date</b>	<b>Text affected</b>
31 December 2011	See foreword

## Contents

0	Introduction	1
<b>Section 1: General</b>		
1	Scope	3
2	Normative references	3
3	Terms and definitions	3
4	Rationale	4
5	Design and use of symbolism	6
<b>Section 2: Compendium</b>		
6	Presentation of the compendium	9
<b>Group 1: Information devices</b>		
<b>Group 2: Materials in section</b>		
<b>Group 3: Land use</b>		
<b>Group 4: Landscape</b>		
<b>Group 5: Building components</b>		
<b>Group 6: Pipes, ducts, drains and sewers</b>		
	Bibliography	37
<b>List of figures</b>		
	Figure 1 – Core Maturity Model	2
	Figure 2 – Examples of symbols/elements and constructed symbols	5
	Figure 3 – Comparison between representations, simplified representation and symbols	5
	Figure 4 – Symbols and attributes	7
	Figure 5 – Symbol and level of detail	8
<b>List of tables</b>		
	Table 1.1 – Datums, levels and orientation	10
	Table 1.2 – Indication of planes and voids	11
	Table 1.3 – Conventions for indicating zones	12
	Table 1.4 – Termination of dimension lines	13
	Table 1.5 – Termination of modular coordination lines <sup>A)</sup>	14
	Table 1.6 – Referencing/cross-referencing	15
	Table 1.7 – Handling of ironmongery for annotating schedules	16
	Table 1.8 – Steps and gradients	17
	Table 1.9 – Alterations and demolitions	18
	Table 2.1 – Wood	19
	Table 2.2 – Manufactured materials	19
	Table 2.3 – Masonry	20
	Table 2.4 – Site-formed materials	21
	Table 3.1 – Drawings for statutory applications	22
	Table 3.2 – Colouring/markings on Land Registry filed plans	23
	Table 4.1 – Ground shaping, surfacing, edges	24
	Table 4.2 – Existing trees	25
	Table 4.3 – Proposed trees	26
	Table 5.1 – Windows in horizontal/vertical section/cut	27
	Table 5.2 – Windows in elevation	28
	Table 5.3 – Doors and doorsets on plans	29
	Table 5.4 – Support, enclosures and holes	30
	Table 5.5 – Way-finding signage	31
	Table 6.1 – Pipes, ducts, drains and sewers	32
	Table 6.2 – Pipe fittings	33

Table 6.3 – Sanitary fittings	35
Table 6.4 – Manholes and gullies	36

**Summary of pages**

This document comprises a front cover, an inside front cover, pages i to iv, pages 1 to 38, an inside back cover and a back cover.

## Foreword

### Publishing information

This part of BS 8541 is published by BSI and came into effect on 30 September 2011. It was prepared by Technical Committee B/555, *Construction design, modelling and data exchange*. A list of organizations represented on this committee can be obtained on request to its secretary.

### Supersession

This part of BS 8541 supersedes BS 1192-3:1987, which is withdrawn.

### Relationship with other publications

BS 8541 comprises four parts as follows:

- *Part 1: Identification and [C1] classification [C1]* <sup>1)</sup>
- *Part 2 (this part): Recommended 2D symbols of building elements for use in building information modelling*
- *Part 3: Shape and measurement* <sup>1)</sup>
- *Part 4: Attributes for specification and assessment* <sup>1)</sup>

### Information about this document

The start and finish of text introduced or altered by Corrigendum No. 1 is indicated in the text by tags [C1] and [C1].

This part of BS 8541 was written to bring the recommendations for construction drawing practice up-to-date and to conform to other national standards of the United Kingdom and with standards of the International Organization for Standardization (ISO) that have been accepted by the UK.

### Use of this document

As a guide, this part of BS 8541 takes the form of guidance and recommendations. It should not be quoted as if it were a specification and particular care should be taken to ensure that claims of compliance are not misleading.

Any user claiming compliance with this part of BS 8541 is expected to be able to justify any course of action that deviates from its recommendations.

### Presentational conventions

The provisions in this standard are presented in roman (i.e. upright) type. Its recommendations are expressed in sentences in which the principal auxiliary verb is "should".

*Commentary, explanation and general informative material is presented in smaller italic type, and does not constitute a normative element.*

The word "should" is used to express recommendations of this standard. The word "may" is used in the text to express permissibility, e.g. as an alternative to the primary recommendation of the clause. The word "can" is used to express possibility, e.g. a consequence of an action or an event.

Notes and commentaries are provided throughout the text of this standard. Notes give references and additional information that are important but do not form part of the recommendations. Commentaries give background information.

---

<sup>1)</sup> In preparation.

**Contractual and legal considerations**

This publication does not purport to include all the necessary provisions of a contract. Users are responsible for its correct application.

**Compliance with a British Standard cannot confer immunity from legal obligations.**

## 0 Introduction

### 0.1 General

This part of BS 8541 is intended for those concerned with the application of symbols and other graphic conventions on drawings and 2D BIM models and for those concerned with the design, development and standardization of such conventions, for the construction industry.

### 0.2 Work within the International Organization for Standardization (ISO)

International agreement has not always been achieved in this field of work: acceptability of symbols internationally is dependent partly on precedent and partly on rationale. Precedent in this context can be determined only by an international survey which, although advocated by the United Kingdom, has not been undertaken. The development of a rationale for the design of new graphic conventions and for the selection of existing graphic conventions demands a major research programme. As yet such a programme has not been undertaken.

### 0.3 UK work

Although not the result of either an international survey or a major research programme, this part of BS 8541 is based on principles of rationale and also on precedent. Graphic conventions proposed by ISO or other authorities that do not conform either to the stated rationale or to national precedent are not included. This part of BS 8541 is the first step towards a theoretical and practical basis for symbols and other graphic conventions for an industry that is constantly progressing and changing. It will, therefore, be necessary for this work to be regularly monitored, adjusted and extended.

### 0.4 Core Maturity Model

Figure 1 shows the Core Maturity Model against which this British Standard assists in the implementation of Building Information Modelling and Management BIM(M).

The purpose of the levels is to categorize types of technical and collaborative working to enable a concise description and understanding of the processes, tools and techniques to be used. The levels are as follows:

- 0 - Unmanaged CAD probably 2D, with paper (or electronic paper) as the most likely data exchange mechanism.
- 1 - Managed CAD in 2 or 3D format using BS 1192:2007 with a collaboration tool providing a common data environment, possibly some standard data structures and formats. Commercial data managed by standalone finance and cost management packages with no integration.
- 2 - Managed 3D environment held in separate discipline "BIM" tools with attached data. Commercial data managed by an ERP. Integration on the basis of proprietary interfaces or bespoke middleware could be regarded as "pBIM" (proprietary). The approach may utilise 4D programme data and 5D cost elements.
- 3 - Fully open process and data integration enabled by IFC/IFD. Managed by a collaborative model server. Could be regarded as iBIM or integrated BIM potentially employing concurrent engineering processes.

This standard for 2D symbology is the first of a number of symbology standards and has been developed to sit within Level 0 and Level 1 of the maturity model.

Figure 1 Core Maturity Model

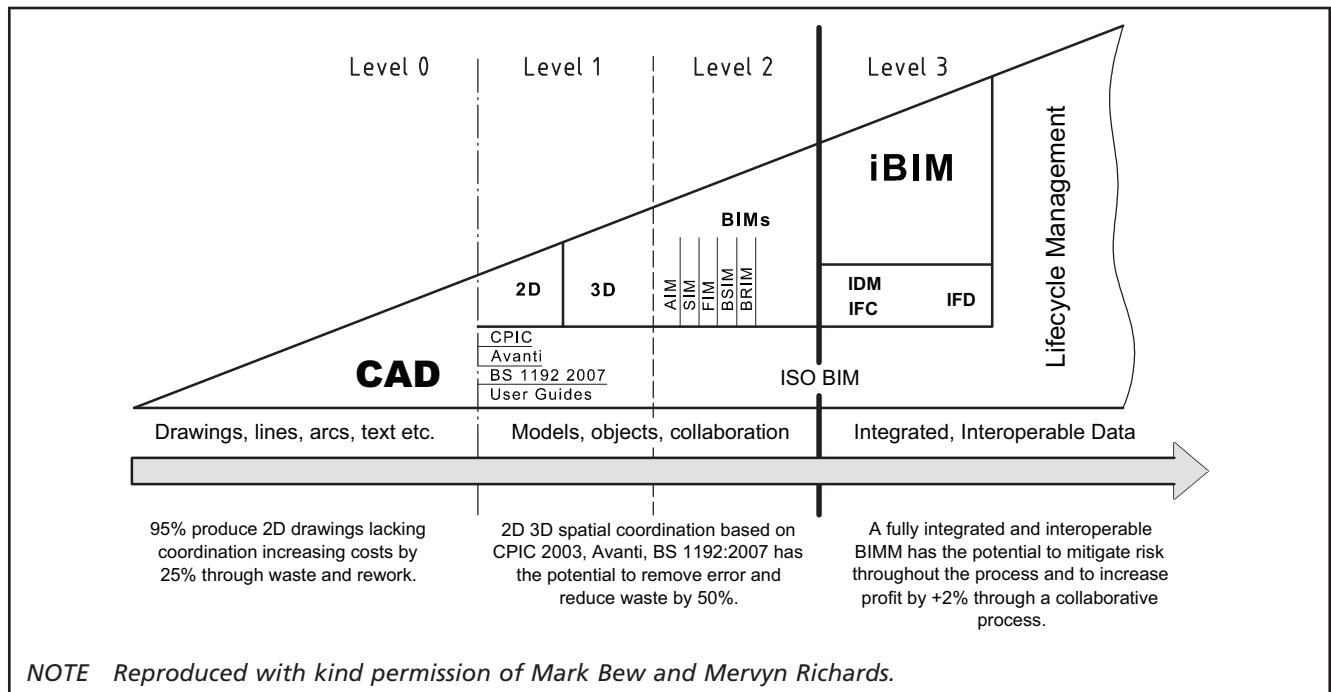

The symbols have been developed to provide consistent 2D representation for drawing renditions and schematics with the basic metadata or attributes required for this level of definition.

Further 3D symbols are to be developed to enable use in 3D models and Building Information environments with the ability to be enhanced to allow for manufacturers' objects, information and data.



# Section 1: General

## 1 Scope

This part of BS 8541 gives guidance and recommendations for symbols and other graphic conventions for use on drawings for the construction industry.

It is primarily intended for those preparing drawings.

The symbols covered by this British Standard is restricted to the architectural and land registry symbols as the base for architecture drawing, modelling and planning activities. The more specific symbols for mechanical, electrical and plumbing along with the structural steel sections and welding are deferred to those institutes that have a greater understanding of the needs of their members in a fast changing world.

*NOTE* For example, BSRIA has a large symbol library for the MEP and Building Services engineers and the Institution of Engineering and Technology (IET) covers both electronic and electrical symbols.

It also describes a rationale of symbolism (Clause 4) which establishes rules for the design of symbols and other graphic conventions, and gives recommendations for the application of those rules and the ways in which symbolism should be used (Clause 5).

It does not include the following:

- symbols applicable to signs for use on buildings or equipment;
- symbols for use on fire protection drawings (which are given in BS 1635).

## 2 Normative references

The following referenced documents are indispensable for the application of this document. For dated references, only the edition cited applies. For undated references, the latest edition of the referenced document (including any amendments) applies.

BS 3975-4, *Glossary for landscape work – Plant description*

BS EN ISO 9431, *Construction drawings – Spaces for drawing and for text, and title blocks on drawing sheets*

## 3 Terms and definitions

For the purposes of this part of BS 8541, the terms and definitions given in BS EN ISO 9431, BS 3975-4 and the following apply.

### 3.1 convention

accepted way of drawing an item which may have the nature of a representation, a simplified representation or a symbol

### 3.2 information device

convention indicating an abstract item

### 3.3 representation

scale view of an object

### 3.4 simplified representation

scale view incorporating only the essential shape, size or features of an object

**3.5 symbol**

graphic device without scale used:

- a) on a drawing to indicate the occurrence and/or location of an item;
- b) in an annotation to indicate one or more of the attributes of an item

**3.6 symbol element (element)**

graphic device without scale used only in combination with a symbol (or symbols) or with other elements, to form a symbol

## 4 Rationale

**4.1 Indication of all features of an object**

Although all the features of an object (subject to the limitations of the scale of the drawing) can be shown on a detailed pictorial view (a representation, see 3.3), there are usually other attributes of the object which need to be described, annotated or referred to in other documents.

**4.2 Limited indication of the features of an object**

To reduce drawing effort and time, a pictorial view such as that described in 4.1 can sometimes, as appropriate, be limited in detail (a simplified representation, see 3.4) but can still need a description, annotation or reference.

**4.3 Non-realistic indication of objects**

To reduce drawing effort and time still further for an object of which the size is not significant on a drawing, especially if many such objects occur, the object can be indicated non-realistically by using a symbol (see 3.5).

**4.4 Symbols sharing common subsidiary features**

Some symbols share common subsidiary features; this part of BS 8541 refers to these features as elements (see 3.6). These can be incorporated in new symbols, can be added to established symbols or can be combined with other elements as needed.

A symbol element should not be used in isolation.

**4.5 Types of symbol**

The simplest form of symbol is the basic symbol.

More complex types of symbol are derived from the basic symbol. There are three ways of deriving symbols:











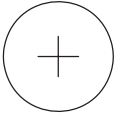



- a) by embellishment of a basic symbol;
- b) by a combination of basic symbols;
- c) by extension of a basic symbol.



Figure 2 gives examples of symbols/elements and constructed symbols.

**4.6 Conventions showing abstract items**

Conventions showing abstract items are referred to as information devices (see 3.2).

Figure 2 Examples of symbols/elements and constructed symbols





	1	2	3
Symbols/elements	any new tree 	luminaire  pole  arm 	fall of ground 
	short standard  half standard  light standard  standard  tall standard  selected standard 	luminaire on pole  luminaire on pole-mounted arm 	bank 

NOTE The symbols given in columns 2 and 3 give examples of elements being combined to produce other  constructed  symbols.

#### 4.7 Comparison between representations, simplified representations and symbols

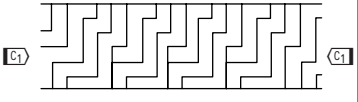
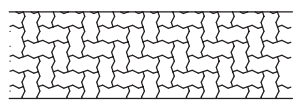
Figure 3 shows a comparison between representations, simplified representations and symbols.

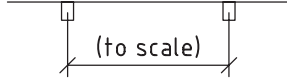
Figure 3 Comparison between representations, simplified representation and symbols

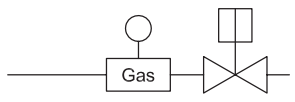
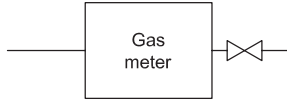
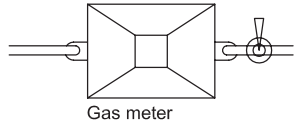
Item	Symbol	Simplified representation	Representation
Interlocking concrete block paving			
Fence			
Gas meter and shut-off valve			

## 5 Design and use of symbolism

### 5.1 Graphic simplicity

The amount of detail in a representation should be appropriate to the scale of the drawing.

The amount of detail in a simplified representation should be limited to the essential attributes of the object (see 3.4 and Figure 3).

*NOTE Geometric shapes for information devices, elements and symbols are limited. Precedent (see the Introduction) can establish that one shape can have several meanings, the relevant meaning being determined normally by context and experience.*

A geometric shape should not be used if its meaning is not determined by context and experience.

Over-complexity of information devices, elements and symbols should be avoided by one of the following methods:

- a) omitting unnecessary information (for example, if all the items in a project are of the same type);
- b) annotating differences between one item and another;
- c) referring differences to a schedule or other document.

### 5.2 Symbols (including elements of symbols)

The size of a symbol does not necessarily relate to the size of an object, or to the scale of a drawing.

The shape of a symbol does not necessarily relate to the shape of an object.

A symbol does not necessarily indicate graphically all the attributes of an item.

A symbol can be combined with an element or a symbol to form another symbol.

A symbol can be added to a convention, a representation, a simplified representation or another symbol. (See Figure 4.)

### 5.3 Graphics

#### 5.3.1 Method of creation

The illustrations in Section 2: *Compendium*, indicate the size of symbolism that should typically be used on drawings. Account has been taken, in the light of evaluation tests, of producing symbolism by:

- a) manual draughting using a 0.35 mm pen, including the manufacture of suitable templates (stencils);
- b) computer draughting;
- c) using dry transfer.

Figure 4 Symbols and attributes

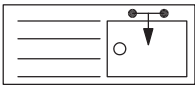
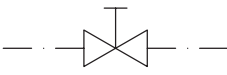
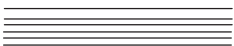
Item	Symbolism	Component parts of symbolism			
		Elements	Conventions	Symbols	Simp. Rep'ns
Sinktop (RH bowl) with mixer tap		7.4 E2	—	7.405	7.4R4
		7.4 E3			
Wheel valve on exposed pipe at high level		—	1.302	7.101 7.313	—
Metal faced plywood		—	—	2.205	—
				2.207	

### 5.3.2 Techniques

Graphic techniques should follow the recommendations in BS EN ISO 9431, and in particular:

- a) line thickness should be not less than 0.25 mm on drawings to be reproduced without reduction, or to be microfilmed;
- b) line thickness should be not less than 0.35 mm on drawings to be reduced by up to 50%;
- c) if different line thicknesses are used, each thickness should be at least twice the next thinner line;
- d) the space between lines should be not less than 0.7 mm;
- e) inclined lines should be at an angle of 15° or a multiple of 15°;
- f) solidly filled areas should be kept to a minimum (because they tend to disappear in successive reproductions): hatching is preferred;
- g) lettering (including numbers) should have a capital height of:
  - 1) not less than 2.5 mm for drawings as in (a) above;
  - 2) not less than 3.5 mm for drawings as in (b) above.

### 5.3.3 Orientation of symbolism excluding elements

The orientation of an element should always be as shown in Section 2: *Compendium*, but the orientation of other types of symbolism should not be regarded as affecting the meaning of the symbolism concerned.

## 5.4 Authority

**5.4.1** Each drawing or set of drawings which uses symbolism drawn from this part of BS 8541 should include a statement to that effect in the information panel of the drawing concerned.

#### EXAMPLE



“The symbols represented on this drawing should be read in conjunction with BS 8541-2...”

**5.4.2** Symbols derived from symbols in this standard should be illustrated and their meaning should be clearly explained on the drawings concerned. Care should be taken to ensure that derived symbols do not become over-complicated.

**5.4.3** When a symbol is taken from other sources, e.g. from BS 1553-1, BS 1635 or BS EN 60617 parts 1 to 8 a statement to that effect should be included in the

information panel of the drawing concerned, the symbol should be illustrated and its meaning should be clearly explained on the drawing.

EXAMPLE

“The symbols represented on this drawing should be read in conjunction with  BS 1553-1 ...”

### 5.5 Level of detail for symbols

Levels of detail in symbology varies depending on the representative scale (see Figure 5):

- a) Low
- b) Medium
- c) High

If the detail is too complex it might not reproduce on the plotted facsimile.

Figure 5 Symbol and level of detail

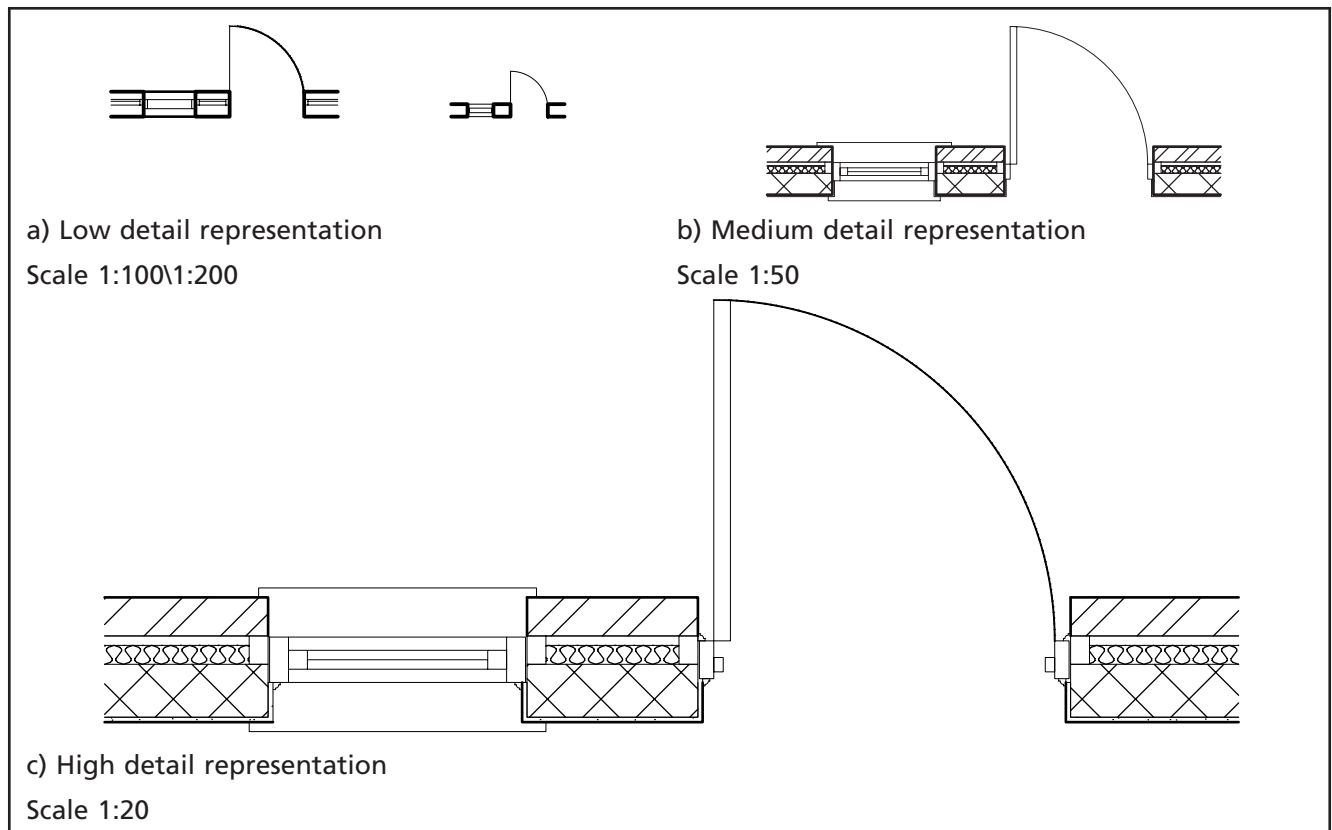

## Section 2: Compendium

### 6 Presentation of the compendium

#### 6.1 General

Section 2 comprises a compendium of symbols and other graphic conventions that are recommended for use on construction drawings. Examples of the application of symbols are given as appropriate. The compendium is organized by subject area.

#### 6.2 Background matrix

C1 Text deleted C1

The background to some elements and symbols incorporates additional lines to indicate, as appropriate, how they should:

- a) be drawn;
- b) relate to the context in which they occur.

#### 6.3 Reference system

**6.3.1** Tables are grouped in broad categories and the group number is the first digit of the table number.

**6.3.2** The second digit of the table number identifies that table within its group.

**6.3.3** Elements are numbered sequentially within their table of origin, with E interposed between the table number and the sequential number.

**6.3.4** Conventions and symbols are numbered sequentially (always with two digits) within their table of origin, the sequential number being suffixed to the table number.

**6.3.5** Elements and symbols originating in other tables and used in a table are only listed in that table; they are illustrated in their tables of origin.

**6.3.6** Applications illustrate examples of conventions and symbols in use, and are not numbered.

**6.3.7** The numbers of the elements and symbols used in applications are listed.

**6.3.8** In Table 6.3 (which covers sanitary fittings), the simplified representations based on ISO 4067-2 are numbered similarly to elements (see **6.3.3**). The difference is that R is interposed instead of E.

#### 6.4 Arrangement of tables

The contents of each table are arranged in the following order:

- a) elements;
- b) elements and symbols from other tables;
- c) conventions;
- d) symbols;
- e) simplified representations;
- f) applications.

*NOTE Not every table includes all these contents.*

## 6.5 Interdependence of tables

Although some groups of tables are related to particular aspects of the construction industry and professions, a group does not contain all the symbolism relevant to its particular aspect.

All the tables in the compendium should therefore be consulted for the symbolism relevant to a drawing.

## Group 1: Information devices

Table 1.1 Datums, levels and orientation

Symbols	Applications
1.101 bench mark	Change of suspended ceiling level at bulkhead
1.102 <sup>A)</sup> datum on plans	
1.103 datum on cuts, sections, elevation	
1.104 <sup>A)</sup> level on plans	1.106 1.302 1.608 Datum and levels on section
1.105 level on cuts, sections, elevations	
1.106 ceiling height above ffl on plans	
1.107 ceiling heights in plan	
1.108 North point	

<sup>A)</sup> Location at cross.



Table 1.2 Indication of planes and voids

Symbols	Applications
1.201 direction of span, floor or roof structure	Part plan of floor with lift well opening
1.202 opening in ceiling/floor/wall/etc.	
	1.201/1.202 1.304

Table 1.3 Conventions for indicating zones

Conventions	Applications <sup>A)</sup>
1.301 behind cutting plane, hidden <sup>B)</sup>	Example of cut (A-A on plan)
1.302 behind cutting plane, visible <sup>B)</sup>	
1.303 beyond cutting plane, visible	
1.304 beyond cutting plane, hidden <sup>B)</sup>	
	Example of plan

<sup>A)</sup> Only part of the cut and plan drawing is shown.

<sup>B)</sup> Behind and beyond cut plane should be avoided where possible to aid drawing clarity.

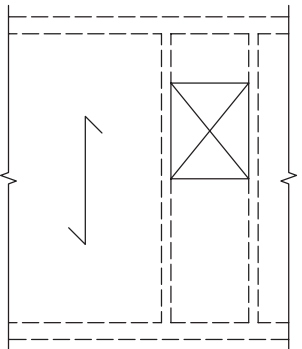
† The cutting plane is not usually drawn on cuts, elevations and sections.







‡ Floor benchmark (see BS 5606).

Table 1.4 Termination of dimension lines

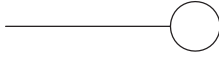
Symbols		Applications	
1.401 open arrowhead <sup>A)</sup>		Dimensions	
1.402 closed arrowhead <sup>A)</sup>			
1.403 oblique stroke <sup>A)</sup>		1.403 Small dimensions	
1.404 dot <sup>A)</sup>		1.408 Running dimensions	
1.405 circle <sup>A)</sup>		1.401/1.406	
1.406 common datum point for running dimensions <sup>A)</sup>		Small running dimensions	
1.407 open arrow for small dimensions <sup>A)</sup>			
1.408 closed arrow for small dimensions <sup>A)</sup>			

<sup>A)</sup> Only one termination should be used on a set of drawings.

Table 1.5 Termination of modular coordination lines <sup>A)</sup>

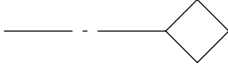
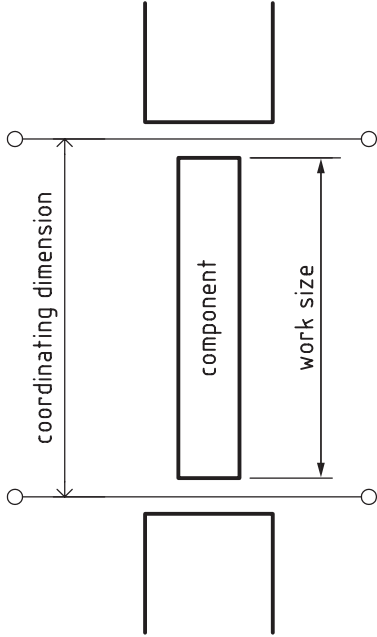
Symbols		Applications	
1.501 key reference plane, any type		Reference line, any type	
1.502 key reference plan, site setting out datum		Centre line, any type	
1.503 dimension line, co-ordinating dimension		Reference line, site setting out	
1.504 dimension line, work size		Centre line, site setting out	
		Dimension of coordinated component showing work size of component	
1.501/1.503/1.504			

<sup>A)</sup> See BS 6750.

Table 1.6 Referencing/cross-referencing

**Symbols**

1.601 to note, from within outline		1.609 detail tag	
1.602 to note, from outline		1.610 detail tag, view title and scale	
1.603 to detail, on same drawing		1.611 to section, on another drawing	
1.604 to detail, on another drawing		1.612 to elevation, on another drawing	
1.605 to another drawing		1.613 to call out, on another drawing	
1.606 to schedule		<b>Applications</b>	
1.607 termination of cutting plane		Plane of change	
1.608 plane/point of change		Point of change	
		1.608	

Table 1.7 Handling of ironmongery for annotating schedules









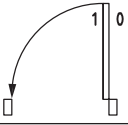
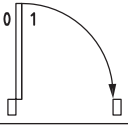
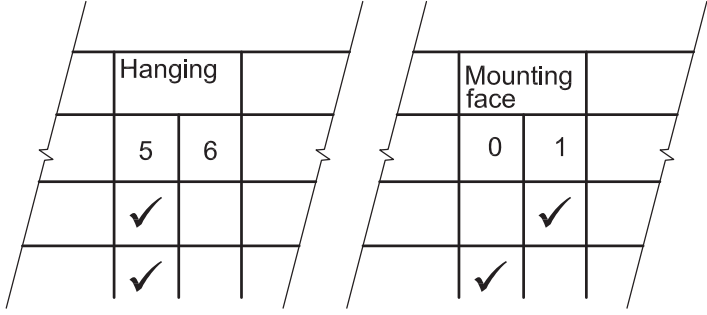
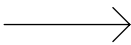
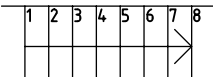

Symbols	Explanatory diagram	
1.701 clockwise closing	<b>5</b>	<b>6</b> 1.702/1.703/1.704
		
		<b>5</b> 1.702/1.703/1.704
		
1.702 anti-clockwise closing	<b>6</b>	
1.703 opening face	<b>0</b>	<b>Application</b>
1.704 closing face	<b>1</b>	Part of schedule
	1.701/1.702 1.703/1.704	

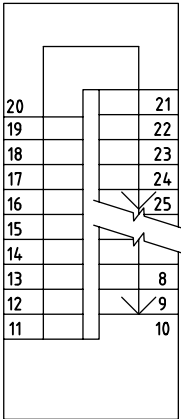
Table 1.8 Steps and gradients

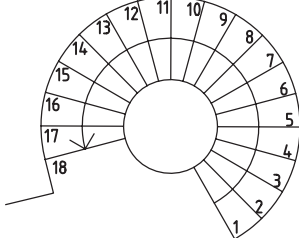
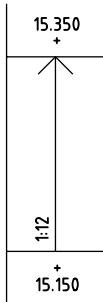
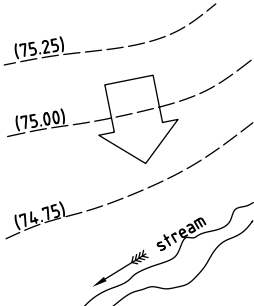
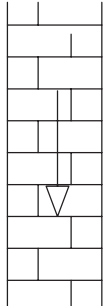
Symbols	Applications <sup>A) B)</sup>
1.801 direction of RISE, ramp/stair/steps	 Straight stairs/steps 1.801 
1.802 direction of FALL, ramp/stair/steps	 Dog leg stairs 1.801 
1.803 direction of FALL, natural drainage	
1.804 direction of FALL, watercourse	
Helical stairs 1.801	
	
Ramp 1.104 1.801	
	
Part of ground survey 1.803/1.804 4.102	
	
Sloping paving 1.802 4.108	
	

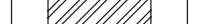
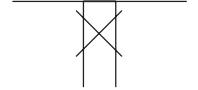
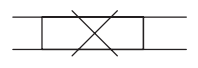
A) Risers should be numbered.  
B) See BS 5395-1.

Table 1.9 Alterations and demolitions

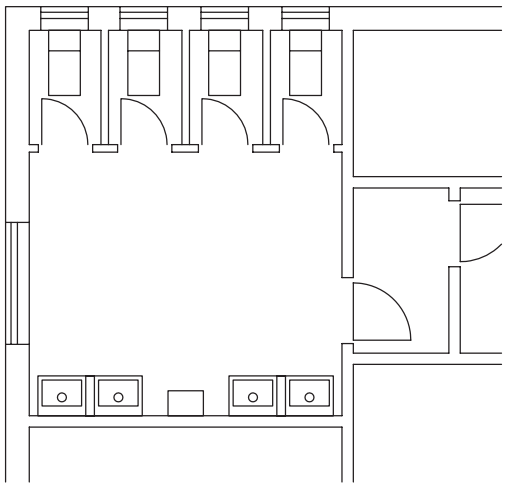
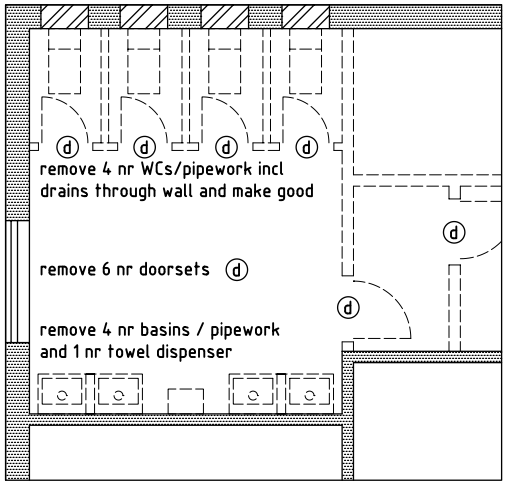
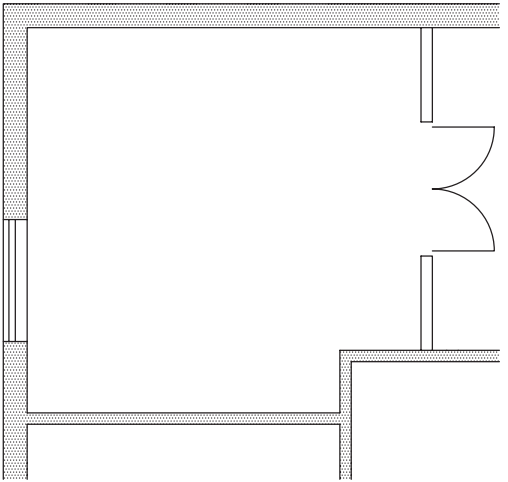
Symbols	Applications
1.901 removal of part 	Part of plan of survey
1.902 removal of area 	5.102 5.301/5.303 5.404 6.3R7/6.3R12
1.903 infilling opening 	
1.904 making good after removal of part 	Part of plan showing alterations and demolitions <b>[C1]</b> Text deleted <b>[C1]</b> shading used to emphasize walls to be retained; annotation used for some items to clarify drawing.
1.905 making good after forming opening 	<b>[C1]</b> Text deleted <b>[C1]</b>
1.906 making good to surface 	
1.907 sealing off 	
1.908 removal of part alternative for manual drawings 	
	
	 <p>remove 4 nr WCs/pipework incl drains through wall and make good</p> <p>remove 6 nr doorsets (d)</p> <p>remove 4 nr basins / pipework and 1 nr towel dispenser</p>
	Part of plan of new work after alterations and demolitions (drawn on copy of alterations and demolitions drawing); shading used to emphasize walls retained and openings infilled.
	2.302 5.102 5.307
	



## Group 2: Materials in section

Table 2.1 Wood







Elements		Symbols	
2.1E1 machining face		2.101 any type, sawn	
2.1E2 straightening face		2.102 any type, machined one face	
		2.103 any type, straightened	
		2.104 any type, thickened	
		2.105 softwood, machined all round	
		2.106 hardwood, machined all round	

Table 2.2 Manufactured materials

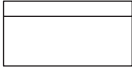

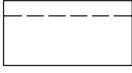

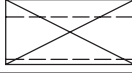

Symbols		Applications	
2.201 board/layer/membrane /quilt/sheet, any type; small scale		Board with membrane of thin sheet facing 2.201/2.203	
2.202 sheet, any type; large scale		Veneered blockboard 2.201/2.208	
2.203 board, any type; large scale		Rolled steel angle 2.207	
2.204 quilt, any type; large scale			
2.205 plywood sheet			
2.206 glass sheet			
2.207 metal sheet			
2.208 blockboard			
2.209 insulation board			
2.210 insulation quilt			
2.211 particle board sheet			

Table 2.3 Masonry

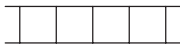
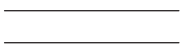
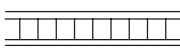



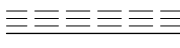

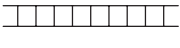
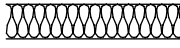
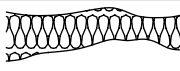
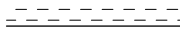



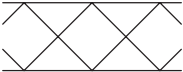
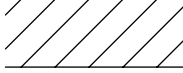
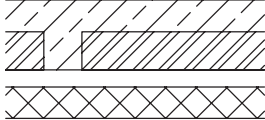

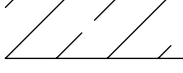
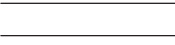
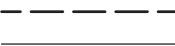
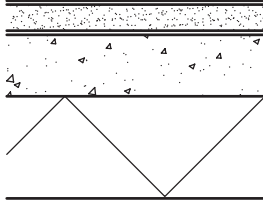

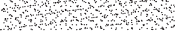

Symbols		Application
2.301 blockwork (low/medium density)		Blockwork/brickwork cavity wall with keyed stonework facing (ashlar)
2.302 blockwork (high density)		
2.303 brickwork		C1 2.301/2.303/2.304 C1
2.304 stonework		

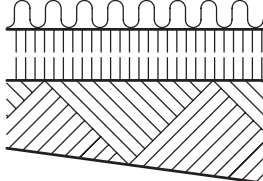
Table 2.4 Site-formed materials

Elements and symbols from other tables	Symbols	Applications	
2.201 board/layer/membrane/quilt sheet, any type, small scale	2.401 layer, any type, faced one side 	Thin flooring on screed on damp proof membrane on concrete slab on separating membrane on hard fill	
	2.201 2.402 layer, any type, irregular surface 		
	2.403 asphalt/macadam 		
	2.404 plaster/render/screed 		2.201 2.401/2.404/2.407
	2.405 concrete 		
	2.406 granular fill 	Mulched topsoil on subsoil	
	2.407 hardfill 		
	2.408 subsoil 		[C1] 2.402/2.408/2.409/2.410 [C1]
	2.409 topsoil 	Asphalt roofing on separating layer on tapered insulation board on vapour barrier on concrete slab	
	2.410 mulch 		
		2.201/2.209 2.401/2.403/2.405	

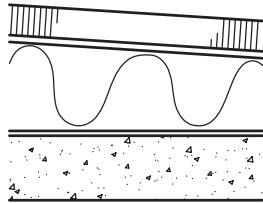
## Group 3: Land use

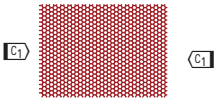
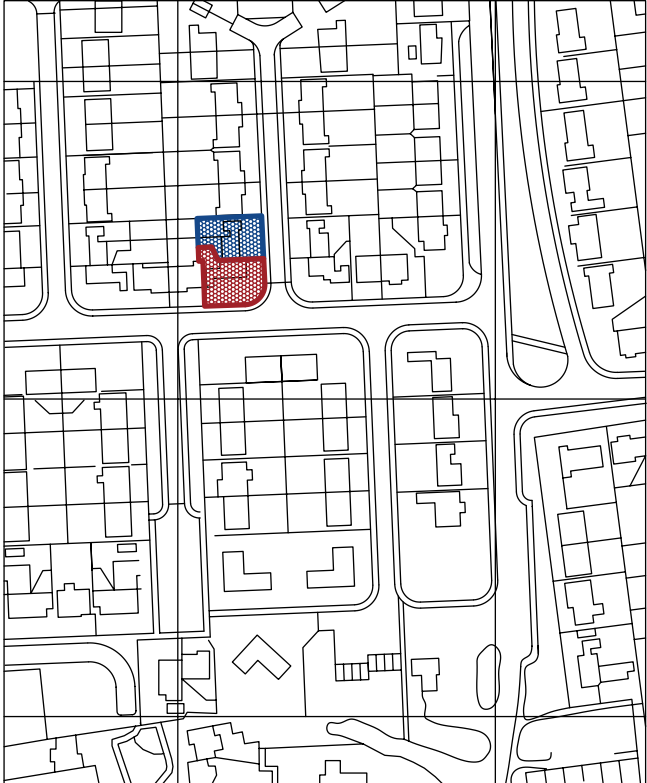
Table 3.1 Drawings for statutory applications

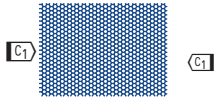
Symbols	Applications
<p>3.101 site, subject of the application</p> 	<p>Site Location Plan showing subject site and adjoining land in the same ownership coloured and should show the direction of North. Typical scale 1:1250 or 1:2500 for larger sites and should show the direction North.</p>
<p>3.102 site, subject of the application</p> 	
<p>3.103 adjoining land, same owner as subject site</p> 	
<p>3.104 adjoining land, same owner as subject site</p> 	

*NOTE The local authority should state if other or additional colourings and/or substituted hatching is required.*

Site Block Plan showing use of hatching and thick outlines to distinguish elements of proposed development and should show the direction of North. Typical Scale 1:200 or 1:500.

**Key**

- A Existing building
- B Part of existing building to be altered
- C New extension
- D Existing access to be extinguished
- E New access

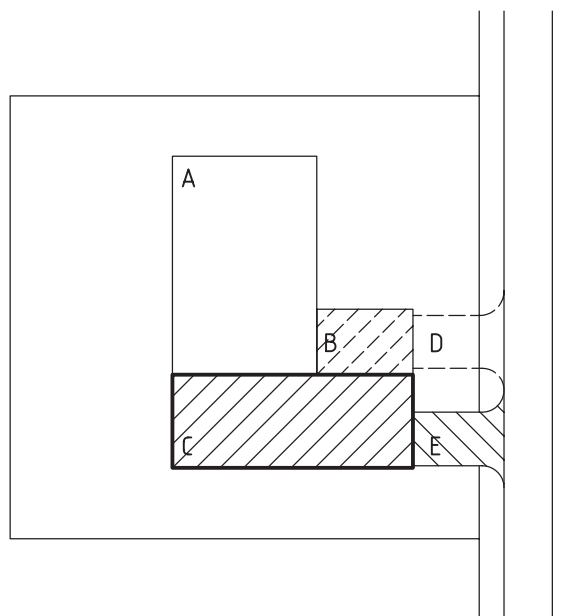

Table 3.2 Colouring/marking on Land Registry filed plans

Conventions		Applications	
3.201 boundary of registered land		Example of filed plan	
3.202 boundary of land removed from title		A Registered land in the title to which the filed plan refers	
3.203 land excluded from title but within area		B Land removed from the title (A)	
3.204 right of way on registered land for use by other land (alternative to 3.205)		C Land excluded from the title (A) but within the area of that title	
3.205 right of way on other land for use by registered land (alternative to 3.204)		D Right of way on land in the title (A) for use by other land (B and C)	
3.206 right of way on other land for use by registered land (alternative to 3.207)		E Right of way on other land for use by land on the title (A)	
3.207 right of way on other land for use by registered land (alternative to 3.206)		(Separate filed plans are prepared for the land within titles B and C and for the land on which area E occurs.)	
3.208 drain/cable/etc., any type		<b>Explanatory notes:</b>	
3.209 <sup>A)</sup> drain/cable/etc., other types	yellow brown mauve	Deed plans: the preferred scale is 1:500, although 1:1 250 can be acceptable; it is very important to HM Land Registry that sites and their features are surveyed and drawn accurately.	
3.210 <sup>A) B)</sup> other features, edging	blue yellow brown mauve	Drawings: should be prepared as recommended with particular attention to their suitability for photocopying in colour	
3.211 <sup>B)</sup> other features, hatching	NOT black or green; NOT blue or brown if already used	Conventions: those shown are normally used by Land Registry on the title plans, and should also be used on draft plans, proposed layout plans and deed plans submitted to Land Registry to avoid difficulties and delays	
3.212 <sup>A) B) C)</sup> other feature, tinting	pink blue (unless already used) yellow, brown mauve	Descriptions: in addition to the colourings/markings, a description should be given of all features (e.g. "... edged in..." and numbered...) if conventions 3.209 to 3.212 are used, their significance should be described	
<sup>A)</sup> In descending order of preference		Advice: HM Land Registry can supply specimen extracts from filed plans and should be consulted in cases of doubt.	
<sup>B)</sup> Other features, e.g. fences, restrictive covenants, etc.			
<sup>C)</sup> Blue tinting should be used to indicate floor levels			

## Group 4: Landscape

Table 4.1 Ground shaping, surfacing, edges

Elements	Symbols	
4.1E1 fall of ground		4.108 <sup>A)</sup> large unit paving
<b>Symbols</b>		4.109 cobble
4.101 contour		4.110 edge, any type
4.102 		4.111 kerbed edge
4.103 line of no cut/no fill		4.112 edge of mowing margin
4.104 ground line (in section)		4.113 point of transition
4.105 existing ground line (in section)		4.114 bank
4.106 cut volume (in section)		4.115 cutting
4.107 <sup>A)</sup> small unit paving		4.116 embankment

### Applications

Plan showing contours, existing contours, line of no cut/no fill

1.607  
4.101/4.102/4.103

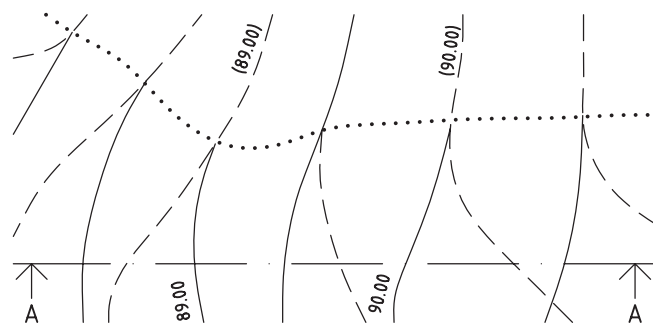

Section A-A on plan showing cut volume, subsoil fill

2.408  
4.104/4.105/4.106

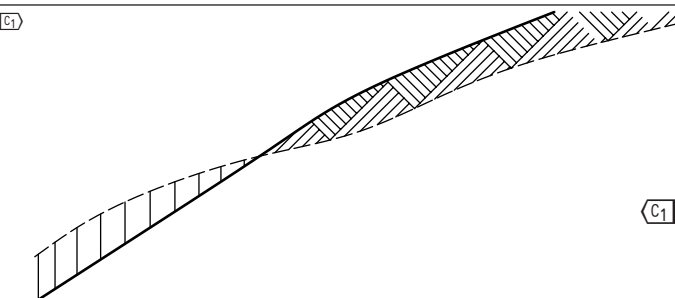





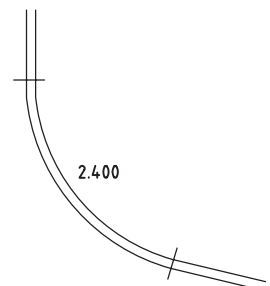

Plan of kerbed edge with curve, radius of curve and points of transition

4.111/4.113

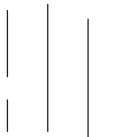





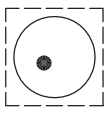





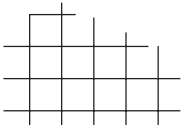



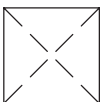



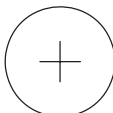









<sup>A)</sup> On large scale drawings, unit paving should be drawn to scale.

Table 4.2 Existing trees

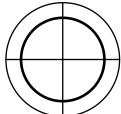
Elements		Symbols		Applications	
4.2E1 trunk		4.201 existing woodland		Protection of trunk 4.202 5.401	
4.2E2 <sup>A)</sup> canopy		4.202 existing tree 4.2E1/4.2E2		Temporary protection of trunk 4.202 5.402	
		4.203 existing tree to be removed 4.2E1/4.2E2		Temporary protection of canopy 4.202 5.402	

<sup>A)</sup> A freehand line can be used.

Table 4.3 Proposed trees

Symbols			
4.301 woodland planting grid		4.314 proposed advanced nursery stock, extra heavy standard	  
4.302 tree pit		4.315 proposed advanced nursery stock, selected heavy standard	  
4.303 proposed tree, any type		4.316 proposed semi-mature tree, any type	  
4.304 proposed transplant or whip			
4.305 proposed nursery stock, any type		<b>Applications</b>	
4.306 proposed nursery stock, short standard		Protection of proposed tree, any type	
4.307 proposed nursery stock, half standard		4.303	
		5.401	
		Temporary protection of proposed tree, any type	
		4.303	
		5.402	
4.308 proposed nursery stock, light standard			
4.309 proposed nursery stock, standard			
4.310 proposed nursery stock, tall standard			
4.311 proposed nursery stock, selected standard			
4.312 proposed advanced nursery stock, any type	  		
4.313 proposed advanced nursery stock, heavy standard	  		



## Group 5: Building components

Table 5.1 Windows in horizontal/vertical section/cut











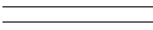
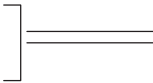
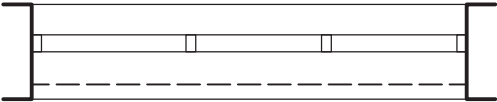

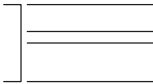

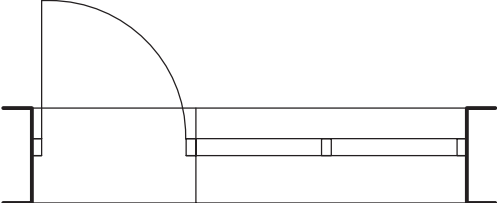



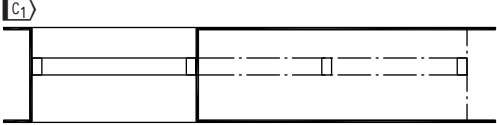

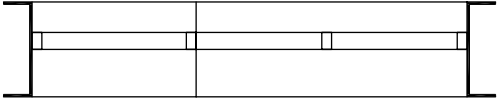
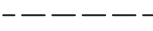
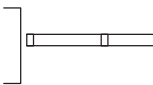

Elements	Symbols	Applications			
5.1E1 zone of frame		5.101 any type 	Plan of window showing frame, mullions and blind (between the jambs)	5.102/5.104/5.106 	
5.1E2 cill/jamb/ threshold		5.102 with cill/jamb/ threshold 	 Plan of window with incorporated door showing frame, mullions, cill and threshold 	5.102/5.104 	
5.1E3 mullion/ perimeter frame/ transom		5.103 with frame 	 Plans of window with change in cill level 	Plan at lower level  	5.102/5.104 Plan at upper level 
5.1E4 accessory		5.104 with frame and mullion/ transom 	Vertical cut through window showing frame transom and internal intruder bars	Vertical cut through window with higher cill, with window beyond  with  lower cill 	
		5.105 with accessory on face of wall 	 	 	
		5.106 with accessory between jambs/cill and head 	 	 	

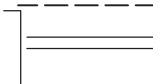
Table 5.1 Windows in horizontal/vertical section/cut

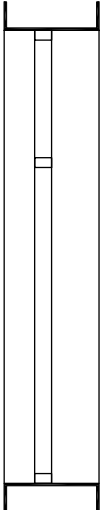
Elements	Symbols	Applications
		5.102/5.104/ 5.105
		1.304 5.102/5.104

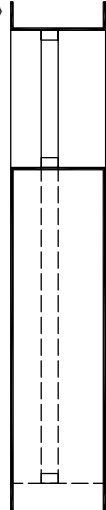
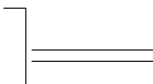
Table 5.2 Windows in elevation







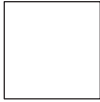
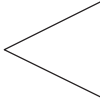
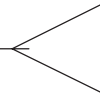

Elements	Symbols	Symbols (continued)
5.2E1 perimeter outline		5.201 any type
5.2E2 hinge (pivot) axis		5.202 fixed
5.2E3 pivot point		5.203 hinged at side
5.2E4 slide to open		5.204 hinged at top
5.2E5 reversible		5.205 hinged at bottom
5.2E6 fixed (not openable)	F	5.206 pivoted, horizontal axis
5.2E7 secondary function	-----	5.207 pivoted, horizontal axis, reversible
		5.208 pivoted, vertical axis
		5.209 pivoted, vertical axis, asymmetrical
5.210 pivoted, vertical axis, reversible		5.211 moving axis, hinged, vertical axis
5.212 moving axis, hinged, horizontal axis		5.213 sliding horizontally
5.214 sliding vertically		5.215 "slide and tilt"
5.216 "slide and tilt" showing secondary function		5.217 "tilt and turn"
5.218 "tilt and turn" showing secondary function		

Table 5.3 Doors and doorsets on plans



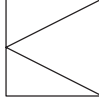
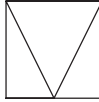
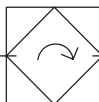
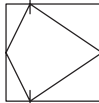

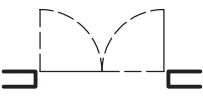

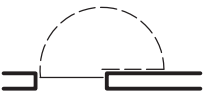



Symbols	Applications	Applications (continued)
5.301 <sup>A)</sup> hinged leaf	1 leaf, any type 5.301	1 leaf, opening either way, any type 5.306
5.302 <sup>A)</sup> hinged leaf	1 leaf, normally closed 5.303	1 leaf, opening either way, normally closed 5.303/5.306
5.303 hinged leaf, normally closed	1 leaf, normally open 5.304	2 leaves, opening either way, any type 5.306
5.304 hinged leaf, normally open	1 ½ leaves, whole leaf any type, half leaf normally closed 5.301/5.303	2 leaves, opening either way, normally closed 5.303/5.306
5.305 hinged leaf, opening 180°, any type	1 ½ leaves both leaves normally closed 5.30	2 leaves, opening either way, normally open 5.304/5.308
5.306 hinged leaf, opening either way, any type	1 ½ leaves both leaves normally open 5.30	Sliding leaf, any type, on face 5.308
5.307 two hinged leaves, any type	2 leaves, any type 5.30	Sliding leaf, normally closed, on face 5.303/5.308
5.308 sliding leaf, any type	2 leaves, both normally closed 5.30	Sliding leaf, normally open, on face 5.304/5.308
5.309 revolving leaves	2 leaves, both normally open 5.30	Sliding leaf, any type, opening into recess 5.308

Table 5.3 Doors and doorsets on plans

Symbols	Applications	Applications (continued)
5.310 sliding- folding leaves, end hung		2 leaves, one normally closed, other normally open 5.30
5.311 sliding- folding leaves, centre hung		1 leaf, opening 180°, any type 5.30
		Revolving leaves 5.309
		Sliding folding leaves, centre hung, opening into recess 5.3011
		1 leaf, opening 180° normally closed 5.30

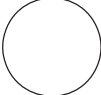









A) Shows the swept path and should be used on drawings if this is significant.

Table 5.4 Support, enclosures and holes

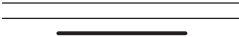
Elements	Symbols
5.4E1 mounting arm	
5.4E2 mounting bollard/pole	
5.4E3 mounting bracket	
5.4E4 suspension cable	
5.4E5 suspension mounting	
5.4E6 restricted access	
	
	
	
	
	

A) The size of the hole should be given in annotation.

Table 5.5 Way-finding signage

Elements and symbols from other tables	Symbols	Applications	
5.404 rectangular casing/outline	5.501 any type	 Single sided sign, illuminated by fluorescent luminaire 5.501	
	5.502 internally illuminated	 Single sided sign, illuminated by spotlight 5.501	
		Single sided sign, fixed flat to wall 5.501	
		Single sided sign, fixed to poles 5.501	
		Twin single sided signs, fixed to poles 5.501	
		Single sided or double sided sign, fixed between poles 5.4E4 5.501	
		Single sided or double sided sign, fixed to end bracket 5.4E3 5.501	
		Single sided or double sided sign, fixed to hangers 5.4E6 5.501	

## Group 6: Pipes, ducts, drains and sewers

Table 6.1 Pipes, ducts, drains and sewers

Symbols	Applications		
6.101 any type			
6.102 direction of flow			
6.103 gradient in direction of flow			
6.104 land drain, any type			
6.105 land drain, mole		<p>(explanatory isometric)</p>	
6.106 French drain			pipe from high level (visible) crossing cutting plane to low level (hidden)
6.107 pipes/ duct crossing, not connected			beyond cutting plane, visible visible drop
6.108 pipes/ duct perpendicular to cutting plane			behind cutting plane, hidden (e.g. in duct)
<b>Applications</b>	1.301/1.303 6.108		
Pipe, duct, drain or sewer showing direction of flow 6.101/6.102			Duct from low level (hidden) cross cutting plane to high level (visible)
Showing fall in direction of flow 6.101/6.102/6.103			
Showing rise in direction of flow 6.101/6.102/6.103			
Duct in two line convention showing direction of flow 6.102			

Table 6.1 Pipes, ducts, drains and sewers

Symbols	Applications
	1.203 1.302/1.304

Table 6.2 Pipe fittings

Elements		Symbols		Symbols (continued)
6.2E1 gas	GAS	6.201 Union joint		6.214 Venturi 
6.2E2 water	WATER	6.202 flanged end		6.215 pressure tapping 
		6.203 flanged joint		6.216 test point 
		6.204 bonded joint		6.217 test/sensor pocket 
<b>Elements and symbols from other tables</b>		6.205 anchor point		6.218 strainer 
5.404 rectangular outline <i>Text deleted</i>		6.206 pipe guide		6.219 steam trap/ separator 
		6.207 sliding coupler		6.220 condensate release trap 
		6.208 flexible coupler		6.221 open vent 
<b>Applications</b>		6.209 capped end		6.222 valved vent 
Orifice plate with pressure tappings <i>Text deleted</i>		6.210 blanking plate		6.223 bottled vent 
Venturi with pressure tappings		6.211 draw off point (tap)		6.224 automatic air vent 
		6.212 spray outlet		6.225 gas meter 

Table 6.2 Pipe fittings

Elements	Symbols	Symbols (continued)
6.213 □ orifice □ plate	 	6.226 water meter 



Table 6.3 Sanitary fittings

Elements		Symbols		Simplified representations on plan (continued)
6.3E1 twin outlet tap		6.301 single tap in taphole		6.3R7 wash basin 
6.3E2 combined outlet tap (mixer)		6.302 single tap on wall plate		6.3R8 wash trough 
6.3E3 tap mounting taphole		6.303 twin outlet tap in taphole		6.3R9 bath 
6.3E4 tap mounting, wallplate		6.304 twin outlet tap on wallplate		6.3R10 shower tray 
6.3E5 waste hole		6.305 combined outlet tap in tapholes		6.3R11 bidet 
6.3E6 drained area		6.306 C1 combined outlet tap on wallplates C1		6.3R12 WC with closed coupled cistern 
6.3E7 for emergency use		6.307 C1 combined outlet tap, monoblock on taphole C1		6.3R13 WC with separate cistern (visible) 
<b>Elements and symbols from other tables</b>		6.308 combined outlet tap, monoblock on wallplate		6.3R14 WC with separate cistern (concealed, e.g. in duct) 
		6.309 combined outlet tap with spray outlet, in tapholes		6.3R15 urinal bowl 
		6.310 combined outlet tap with spray outlet, on wallplates		6.3R16 urinal stall 
5.403 circular casing/outline				6.3R17 drinking water fountain 
5.404 rectangular casing/outline				6.3R18 eyewash fountain 
6.211 tap				
6.212 spray outlet				
		<b>Simplified representations on plan <sup>A)</sup></b>		

Table 6.3 Sanitary fittings

Elements	Symbols	Simplified representations on plan (continued)
6.3R1 sink, any type		6.3R19 emergency shower
6.3R2 bucket sink		
6.3R3 shelf sink		
6.3R4 sinktop, RH bowl		
6.3R5 sinktop, LH bowl		
6.3R6 double bowl sinktop		

† Waste holes should be positioned as required.

<sup>A)</sup> Typically applies to scale 1:200. More detailed symbols for larger scales to be used.

Table 6.4 Manholes and gullies

Elements	Symbols	Symbols (continued)
horizontal inlet		rectangular manhole  access point (rodding eye)
vertical inlet		circular manhole  petrol/oil/ grease separator
back drop		rectangular back drop manhole
separator		circular back drop manhole  horizontal inlet gully
		sealed invert access plate  vertical inlet gully

## Bibliography

For dated references, only the edition cited applies. For undated references, the latest edition of the referenced document (including any amendments) applies.

BS 1192:2007, *Collaborative production of architectural, engineering and construction information – Code of practice*

BS 1553-1, *Specification for graphical symbols for general engineering – Part 1: Piping systems and plant*

BS 1635, *Recommendations for graphic symbols and abbreviations for fire protection drawings*

BS 5395-1, *Stairs – Part 1: Code of practice for the design of stairs with straight flights and winders*

BS 5606, *Guide to accuracy in building*

BS 6750, *Specification for modular coordination in building*

BS EN 60617 (parts 1 to 8), *Graphical symbols for diagrams*

ISO 4067-2, *Building and civil engineering drawings – Installations – Part 2: Simplified representation of sanitary appliances*





# British Standards Institution (BSI)

BSI is the independent national body responsible for preparing British Standards and other standards-related publications, information and services.

It presents the UK view on standards in Europe and at the international level.

It is incorporated by Royal Charter.

## Revisions

British Standards are updated by amendment or revision. Users of British Standards should make sure that they possess the latest amendments or editions.

It is the constant aim of BSI to improve the quality of our products and services. We would be grateful if anyone finding an inaccuracy or ambiguity while using this British Standard would inform the Secretary of the technical committee responsible, the identity of which can be found on the inside front cover.

**Tel: +44 (0)20 8996 9001 Fax: +44 (0)20 8996 7001**

BSI offers Members an individual updating service called PLUS which ensures that subscribers automatically receive the latest editions of standards.

**Tel: +44 (0)20 8996 7669 Fax: +44 (0)20 8996 7001**

**Email: [plus@bsigroup.com](mailto:plus@bsigroup.com)**

## Buying standards

You may buy PDF and hard copy versions of standards directly using a credit card from the BSI Shop on the website [www.bsigroup.com/shop](http://www.bsigroup.com/shop). In addition all orders for BSI, international and foreign standards publications can be addressed to BSI Customer Services.

**Tel: +44 (0)20 8996 9001 Fax: +44 (0)20 8996 7001**

**Email: [orders@bsigroup.com](mailto:orders@bsigroup.com)**

In response to orders for international standards, it is BSI policy to supply the BSI implementation of those that have been published as British Standards, unless otherwise requested.

## Information on standards

BSI provides a wide range of information on national, European and international standards through its Knowledge Centre.

**Tel: +44 (0)20 8996 7004 Fax: +44 (0)20 8996 7005**

**Email: [knowledgecentre@bsigroup.com](mailto:knowledgecentre@bsigroup.com)**

Various BSI electronic information services are also available which give details on all its products and services.

**Tel: +44 (0)20 8996 7111 Fax: +44 (0)20 8996 7048**

**Email: [info@bsigroup.com](mailto:info@bsigroup.com)**

BSI Subscribing Members are kept up to date with standards developments and receive substantial discounts on the purchase price of standards. For details of these and other benefits contact Membership Administration.

**Tel: +44 (0)20 8996 7002 Fax: +44 (0)20 8996 7001**

**Email: [membership@bsigroup.com](mailto:membership@bsigroup.com)**

Information regarding online access to British Standards via British Standards Online can be found at [www.bsigroup.com/BSOL](http://www.bsigroup.com/BSOL)

Further information about BSI is available on the BSI website at [www.bsigroup.com/standards](http://www.bsigroup.com/standards)

## Copyright

Copyright subsists in all BSI publications. BSI also holds the copyright, in the UK, of the publications of the international standardization bodies. Except as permitted under the Copyright, Designs and Patents Act 1988 no extract may be reproduced, stored in a retrieval system or transmitted in any form or by any means – electronic, photocopying, recording or otherwise – without prior written permission from BSI. This does not preclude the free use, in the course of implementing the standard of necessary details such as symbols, and size, type or grade designations. If these details are to be used for any other purpose than implementation then the prior written permission of BSI must be obtained. Details and advice can be obtained from the Copyright & Licensing Manager.

**Tel: +44 (0)20 8996 7070**

**Email: [copyright@bsigroup.com](mailto:copyright@bsigroup.com)**

## BSI Group Headquarters

389 Chiswick High Road London W4 4AL UK

Tel +44 (0)20 8996 9001

Fax +44 (0)20 8996 7001

[www.bsigroup.com/standards](http://www.bsigroup.com/standards)