

# Children's beds for domestic use – Safety requirements and test methods

ICS 97.140

**Publishing and copyright information**

The BSI copyright notice displayed in this document indicates when the document was last issued.

© BSI 2008

ISBN 978 0 580 59411 3

The following BSI references relate to the work on this standard:

Committee reference CW/41

Draft for comment 08/30168262 DC

**Publication history**

First published August 2008

**Amendments issued since publication**

<b>Amd. no.</b>	<b>Date</b>	<b>Text affected</b>
-----------------	-------------	----------------------

---

# Contents

Foreword *iii*

1	Scope	1
2	Normative references	1
3	Terms and definitions	1
4	General requirements	2
5	Chemical hazards	12
6	Thermal hazards	12
7	Mechanical hazards – gaps and openings	13
8	Mechanical hazards – folding	16
9	Mechanical hazards – crushing and shearing	17
10	Mechanical hazards – protruding parts	17
11	Mechanical hazards – entanglement in cords, ribbons and similar parts	18
12	Mechanical hazards – small parts	18
13	Mechanical hazards – suffocation	19
14	Mechanical hazards – edges and protruding parts	20
15	Mechanical hazards – points and wires	20
16	Mechanical hazards – inadequate structural integrity – materials and fastenings	20
17	Mechanical hazards – inadequate structural integrity – vertical static strength of bed base edges	21
18	Mechanical hazards – inadequate structural integrity – vertical impact strength of bed base	21
19	Mechanical hazards – inadequate structural integrity – durability of bed base	22
20	Mechanical hazards – inadequate structural integrity – durability of bed edge	23
21	Mechanical hazards – inadequate structural integrity – strength of head and foot boards	24
22	Mechanical hazards – inadequate structural integrity – strength of side guards and/or safety rails	24
23	Mechanical hazards – inadequate structural integrity – strength of top rails for four poster features	25
24	Product information	26

## List of figures

Figure 1	Hip probe	3
Figure 2	Head probe	4
Figure 3	V and irregular shaped openings template	4
Figure 4	Finger probe with hemispherical end	5
Figure 5	Finger probe with conical end	5
Figure 6	Conical probe	6
Figure 7	Loop and mass	7
Figure 8	Ball chain	7
Figure 9	Small parts cylinder	8
Figure 10	Bed base impactor	9
Figure 11	Striking surface	10
Figure 12	Bed base loading pad	10
Figure 13	Naturalistically shaped loading pad geometry: moulded fibre glass construction	11
Figure 14	Method of insertion of portion B	14
Figure 15	Method of insertion of portion B	14
Figure 16	Method of insertion of portion A	15

Figure 17 – Vertical static strength test of bed edge 21  
Figure 18 – Vertical impact points 22  
Figure 19 – Durability of bed base test positions 23  
Figure 20 – Loading of top side rail 25  
Figure 21 – Loading of top end rail 26

**Summary of pages**

This document comprises a front cover, an inside front cover, pages i to iv, pages 1 to 27 and a back cover.

# Foreword

## Publishing information

This British Standard is published by BSI and came into effect on 29 August 2008. It was prepared by Technical Committee CW/41, *Child use and care articles*. A list of organizations represented on this committee can be obtained on request to its secretary.

## Information about this document

This is a new standard, which has been written to cover children's beds that fall outside the scope of BS EN 716.

## Use of this document

It has been assumed in the preparation of this British Standard that the execution of its provisions will be entrusted to appropriately qualified and experienced people, for whose use it has been produced.

## Presentational conventions

The provisions of this standard are presented in roman (i.e. upright) type. Its requirements are expressed in sentences in which the principal auxiliary verb is "shall".

*Commentary, explanation and general informative material is presented in smaller italic type, and does not constitute a normative element.*

## Contractual and legal considerations

This publication does not purport to include all the necessary provisions of a contract. Users are responsible for its correct application.

**Compliance with a British Standard cannot confer immunity from legal obligations.**

Licensed Copy: :FULLNAME, : DATE, Uncontrolled Copy, (c) BSI

## 1 Scope

This British Standard specifies requirements for the safety of children's beds for domestic use with a maximum internal width of 1 000 mm and a maximum height of bed base of 400 mm.

The requirements apply to children's beds that are fully assembled and ready for use.

This British Standard does not apply to foldaway beds, bunk and high beds, cabin/mid-height beds, children's cots, bedside cots and children's cots that allow free access for the child by means of a hinged opening or removal of some vertical bars/slats.

This standard does not cover products that have been incorporated into children's beds, for example luminaires, tables or storage furniture.

## 2 Normative references

The following referenced documents are indispensable for the application of this document. For dated references, only the edition cited applies. For undated references, the latest edition of the referenced document (including any amendments) applies.

BS EN 71-1, *Safety of toys – Part 1: Mechanical and physical properties*

BS EN 71-2:2006, *Safety of toys – Part 2: Flammability*

BS EN 71-3, *Safety of toys – Part 3: Specification for migration of certain elements*

BS EN 716 (all parts), *Furniture – Children's cots and folding cots for domestic use*

BS EN 717-2, *Wood-based panels – Determination of formaldehyde release – Part 2: Formaldehyde release by the gas analysis method*

BS EN 1084, *Plywood – Formaldehyde release classes determined by the gas analysis method*

BS EN 1103, *Textiles – Fabrics for apparel – Detailed procedure to determine the burning behaviour*

BS EN ISO 2439:2001, *Flexible cellular polymeric materials – Determination of hardness (indentation technique)*

BS EN ISO 14184-1, *Textiles – Determination of formaldehyde – Part 1: Free and hydrolyzed formaldehyde (water extraction method)*

## 3 Terms and definitions

### 3.1 child's bed

cot bed, toddler bed or junior bed

### 3.2 cot bed

bed converted from a cot for use by one child aged 18 months to 4 years

### 3.3 toddler bed

bed for use by one child aged 18 months to 4 years with a maximum internal length of 1 500 mm

*NOTE This might include child appealing designs such as cars, castles and four poster beds.*

### 3.4 junior bed

bed for use by one child aged over 4 years

*NOTE This might include child appealing designs such as cars, castles and four poster beds.*

### 3.5 side guard

component that is higher than the mattress and extends along one side of the child's bed for about one third of the bed's total length

### 3.6 safety rail

component that is higher than the mattress and extends along the entire length of the child's bed, fixed to both head and foot boards

## 4 General requirements

### 4.1 Guards and safety rails

Side guards or safety rails shall not be fitted to junior beds.

*NOTE Side guards and safety rails may be fitted to cot beds and toddler beds.*

### 4.2 Mattresses

If mattress is supplied with the child's bed, the gap between the mattress and the sides and ends of the child's bed shall be no greater than 30 mm with the mattress in any position.

### 4.3 Cot beds

*NOTE A cot may be converted into a cot bed by having either both sides or a single side completely removed and different foot and/or head boards fitted.*

**4.3.1** A cot bed, when assembled as a cot, shall conform to BS EN 716 and then the same sample, assembled as a cot bed, shall be assessed to this standard.

**4.3.2** One sample of a cot bed shall undergo the structural integrity testing of BS EN 716 and of this standard without failure.

### 4.4 Test conditions

**4.4.1** Tests shall be carried out in ambient conditions of 15 °C to 25 °C.

**4.4.2** The tests shall be applied to children's beds that are fully assembled and ready for use.

If of knock-down type, the child's bed shall be assembled according to the manufacturer's instructions. Knock-down fittings shall be tightened before testing and not be retightened throughout the testing procedures unless this is specifically required by the manufacturer.



If the child's bed can be assembled or combined in different ways, the most onerous combinations shall be used for each test.

4.4.3 Unless otherwise stated, tests shall be carried out on the same sample in the order listed in this standard.

## 4.5 Apparatus

4.5.1 Unless otherwise stated, the following tolerances shall apply.

- Forces:  $\pm 5\%$  of the nominal force.
- Masses:  $\pm 0.5\%$  of the nominal mass.
- Dimensions:  $\pm 1.0$  mm of the nominal dimension.
- Angles:  $\pm 2^\circ$  of the nominal angle.
- Positioning of loading pads:  $\pm 5$  mm.
- Duration of forces:  $2\text{ s} \pm 1\text{ s}$  for durability tests/ $10\text{ s} \pm 2\text{ s}$  for static load tests.

*NOTE 1* The tests are described in terms of the application of forces, however masses can be used.

*NOTE 2* Unless otherwise specified, the test forces may be applied by any suitable device which does not adversely affect the results.

4.5.2 *Hip probe*, made from plastics or other hard, smooth material with the dimensions given in Figure 1.

Figure 1 Hip probe

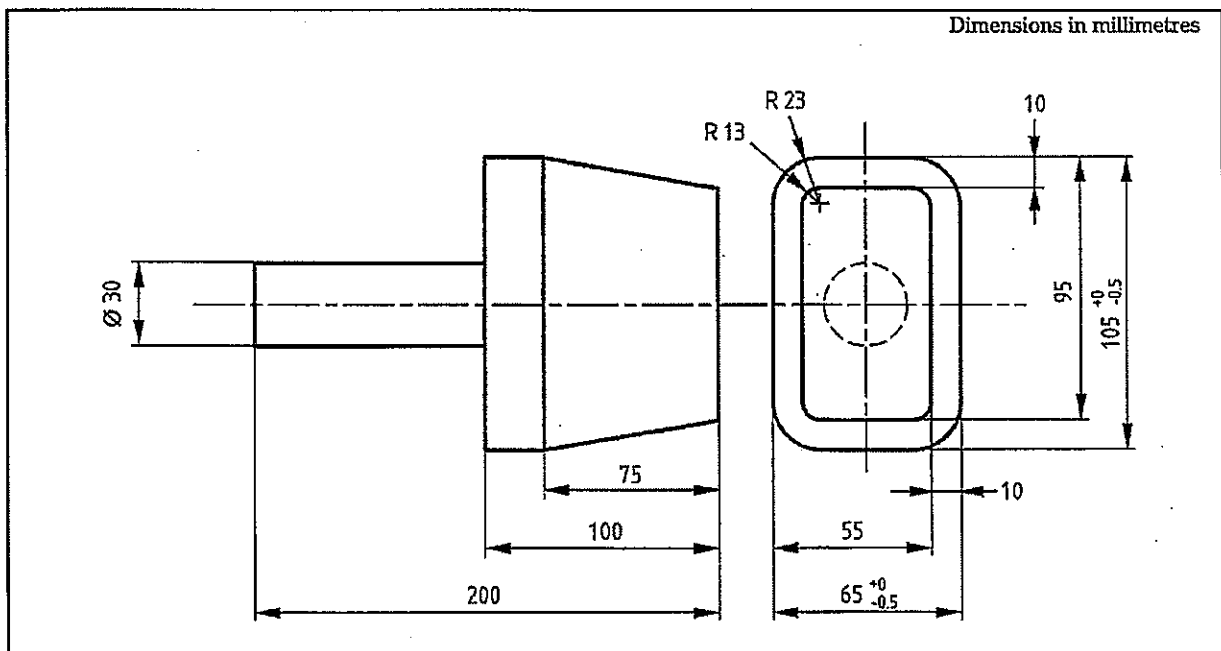

4.5.3 *Head probe*, made from plastics or other hard, smooth material with the dimensions given in Figure 2.

Figure 2 Head probe

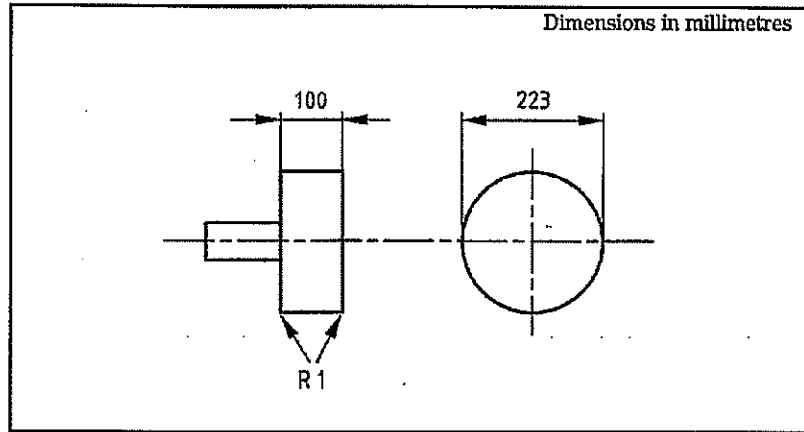

4.5.4 V and irregular shaped template, made from plastics or other hard, smooth material with the dimensions given in Figure 3.

Figure 3 V and irregular shaped openings template

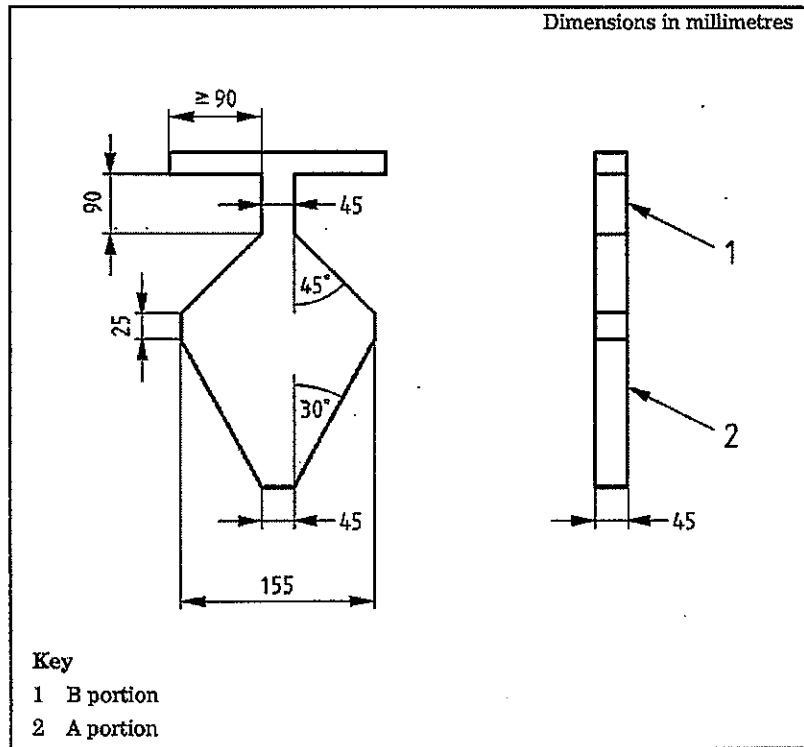

4.5.5 Two finger probes with hemispherical ends, one of 7 mm diameter and the other 12 mm, made from plastics or other hard smooth material (see Figure 4), and capable of being mounted on a device for exerting force in such a way that the hemispherical ends can be presented to openings.

Figure 4 Finger probe with hemispherical end

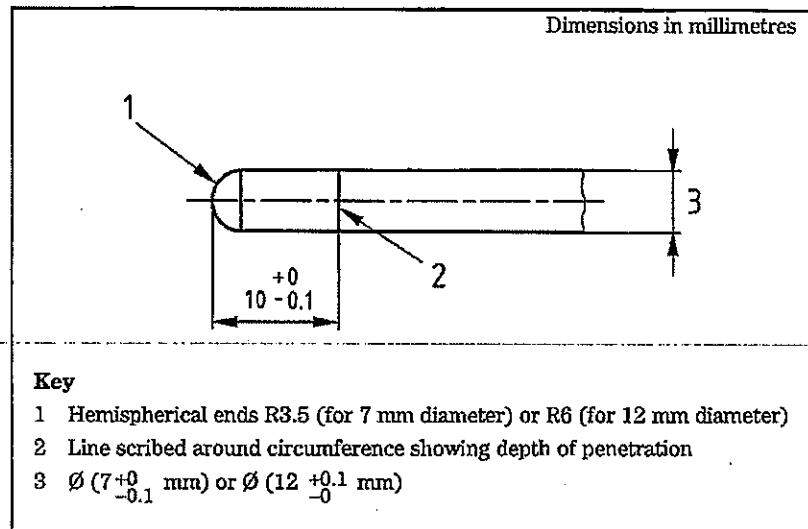

**4.5.6** *Finger probe with a conical end*, of 7 mm diameter, made from plastics or other hard smooth material (see Figure 5), and capable of being mounted on a device for exerting force in such a way that the conical end can be presented to openings.

Figure 5 Finger probe with conical end

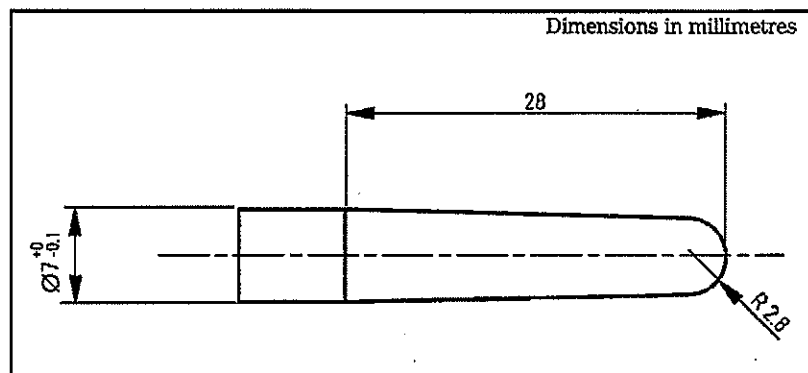

**4.5.7** *Three probes with conical ends*, made of plastics or other hard, smooth material, and capable of being mounted on a device for exerting force in such a way that the conical ends can be presented to openings, each with:

- a) an angle of  $30^\circ \pm 0.5^\circ$ ; and
- b) diameters of:  $25^{+0.1}_{-0}$  mm),  $60^{+0.1}_{-0}$  mm) or  $85^{+0.1}_{-0}$  mm) as applicable (see Figure 6).

Figure 6 Conical probe

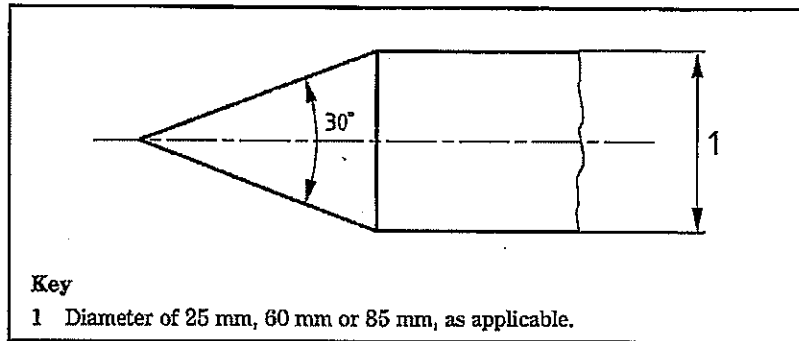

**4.5.8 Ball chain loop attached to a spherical mass** (see Figure 7):

- a) the ball chain comprising a chain of balls each with a diameter of  $3.2 \text{ mm} \pm 0.1 \text{ mm}$  and with a distance of 4 mm between ball centres (see Figure 8);
- b) the smooth spherical mass being  $2.5 \text{ kg} \pm 0.05 \text{ kg}$  with a diameter of 115 mm;
- c) the ball chain loop being formed by entering the ball chain into the spherical mass at a common fixing point with a ball from each side of the chain in contact with each other;
- d) the external peripheral length of the ball chain loop being  $400 \begin{smallmatrix} +5 \\ -0 \end{smallmatrix} \text{ mm}$ .

Figure 7 Loop and mass

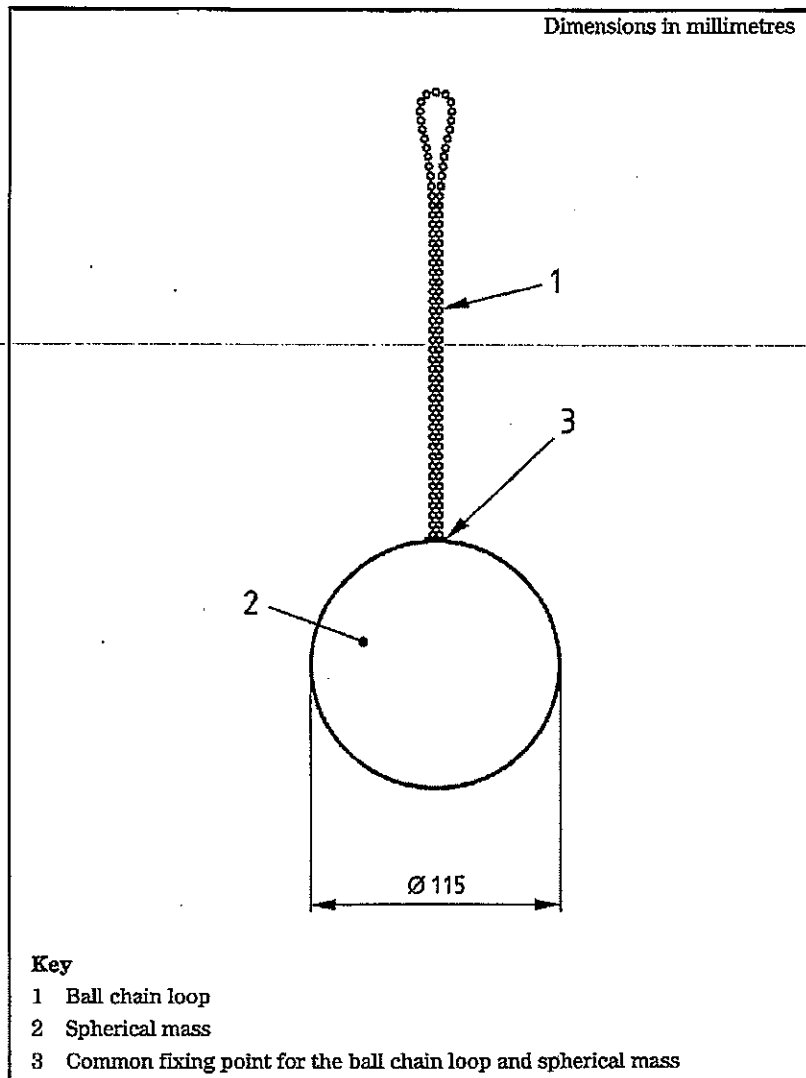
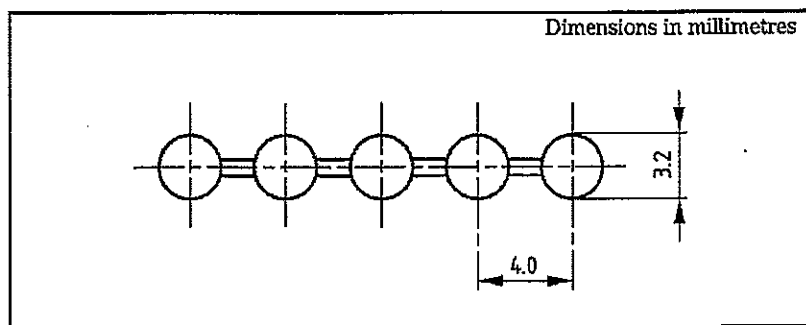
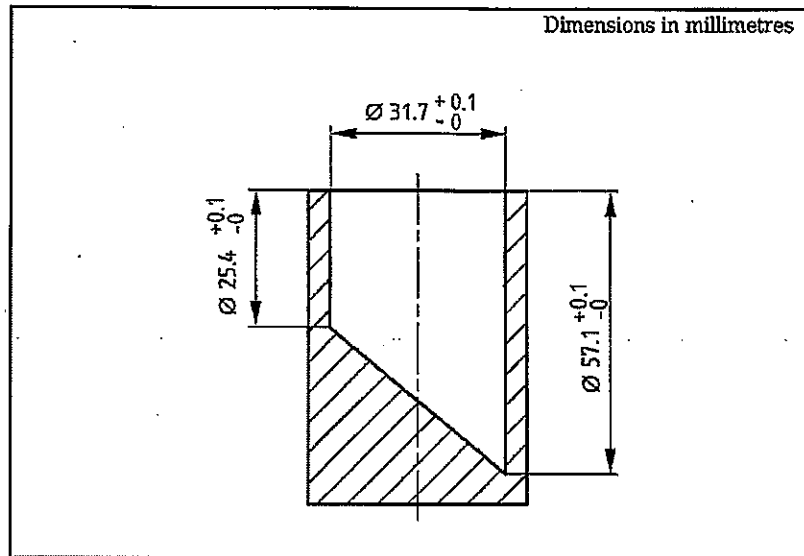

Figure 8 Ball chain



4.5.9 *Cylinder*, having the main dimensions given in Figure 9.

Figure 9 Small parts cylinder



4.5.10 *Two bed edge loading pads*, being cylinders made from hard rigid material with a diameter of 100 mm and edges of 12 mm radius, and smooth surfaces.

4.5.11 *Test mattress* which:

- a) is bigger than the loading pad by at least 100 mm all round,
- b) comprises a soft polyether foam sheet with:
  - a thickness of 100 mm;
  - a bulk density of  $30 \text{ kg/m}^3 \pm 2 \text{ kg/m}^3$ ; and
  - an indentation hardness index of  $170 \text{ N} \pm 20 \text{ N}$ , in accordance with BS EN ISO 2439:2001, 7.2.

The test mattress may have a cover which shall have the following characteristics:

- composition: pure cotton;
- weave in plain: 1/1;
- mass per unit area:  $100 \text{ g/m}^2$  to  $120 \text{ g/m}^2$ ;
- warp and weft: 20 to 30 threads/cm;
- finishing: washed, no finishing agents;
- cover make up: tight fit, but with no restriction on the foam.

The same part of the test mattress shall not be re-used within two hours and the mattress shall be replaced if damaged or after five complete bed tests.

4.5.12 *Bed base impactor* (see Figure 10), having the following characteristics:

- a) a nominal diameter of 200 mm;
- b) separated from the striking surface by helical compression springs, with a combined:
  - spring rate of  $6.9 \text{ N/mm} \pm 1 \text{ N/mm}$ ;

- total friction resistance of the moving parts of between 0.25 N and 0.45 N;
  - compression to an initial load of  $1\,040\text{ N} \pm 5\text{ N}$  (measured statically);
  - spring compression movement, available from the initial compression point to the point where the springs become fully closed, of not less than 60 mm;
- c) free to move relative to the striking surface on a line perpendicular to the plane of the central area of the striking surface (see Figure 11), the striking surface being a rigid circular object, 200 mm in diameter, the face of which has a convex spherical curvature of 300 mm radius with a 12 mm front edge radius;
- d) the body and associated parts minus the springs having a mass of  $17\text{ kg} \pm 0.1\text{ kg}$ ;
- e) the whole apparatus, including mass, springs and striking surface, having a mass of  $25\text{ kg} \pm 0.1\text{ kg}$ ;
- f) connecting part to a lifting device which does not restrain the free fall.

Figure 10 Bed base impactor

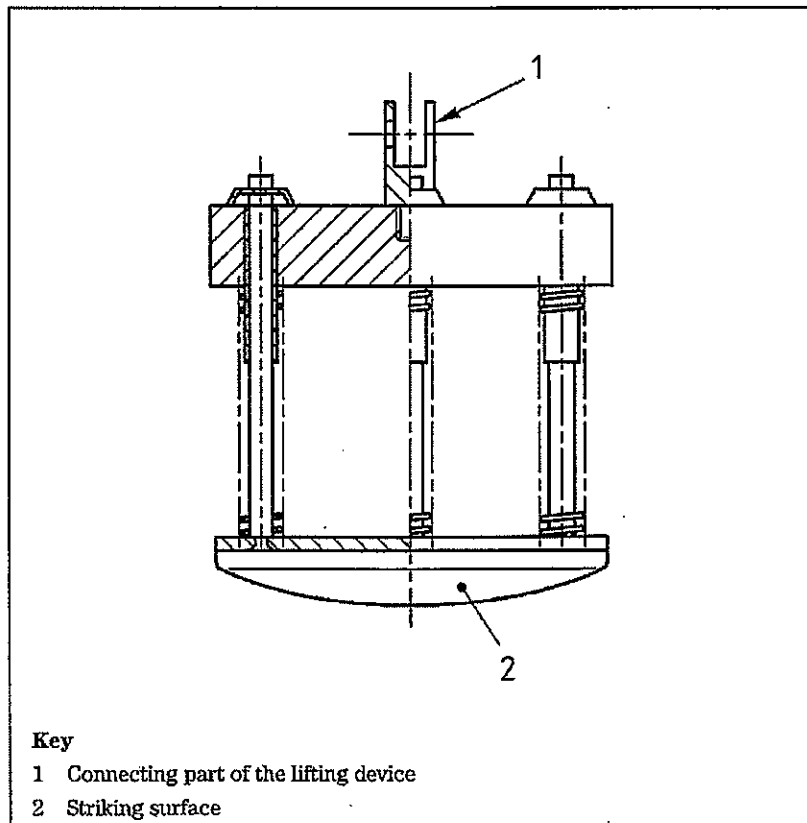
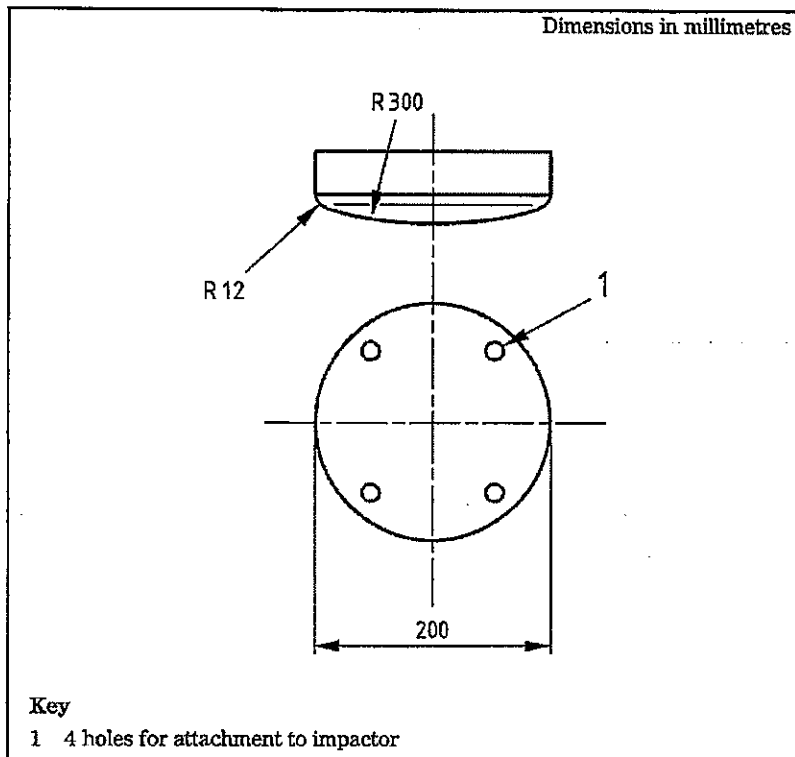
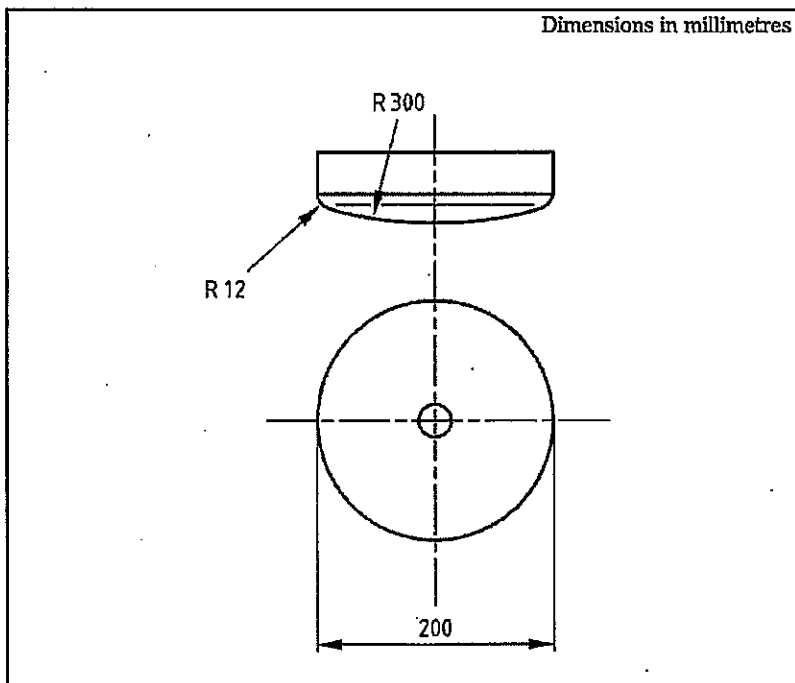

Figure 11 Striking surface



4.5.13 *Bed base loading pad*, being a rigid circular object 200 mm in diameter, the face of which has a convex spherical curvature of 300 mm radius with a 12 mm front edge radius, see Figure 12.

Figure 12 Bed base loading pad





4.5.14 *Naturalistically shaped loading pad* with a hard, smooth surface made from moulded fibre glass with the dimensions and geometry as specified in Figure 13.

Figure 13 **Naturalistically shaped loading pad geometry: moulded fibre glass construction**

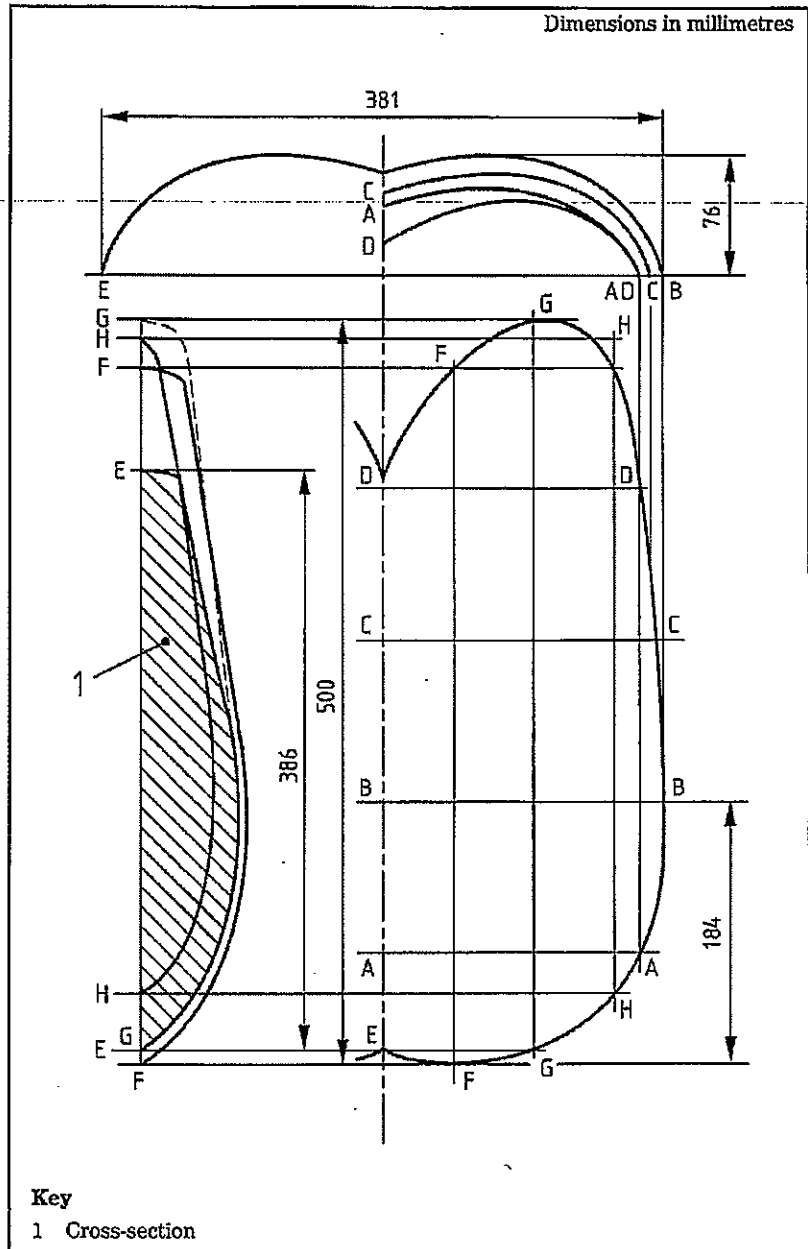

4.5.15 *Test machine*, such that a bed edge loading pad can be mounted and pivoted in a vertical plane about its transverse axis.

## 5 Chemical hazards

### 5.1 Migration of certain elements

When tested in accordance with BS EN 71-3, the migration of synthetic or natural elements from coatings of paint, varnish, lacquer and/or polymer and similar coatings on exterior surfaces shall not exceed the following.

Antimony	60 mg/kg.
Arsenic	25 mg/kg.
Barium	1 000 mg/kg.
Cadmium	75 mg/kg.
Chromium	60 mg/kg.
Lead	90 mg/kg.
Mercury	60 mg/kg.
Selenium	500 mg/kg.

Where a surface is coated with a multi-layer of paint or similar coating, the test specimen shall not include the base material.

*NOTE A separate sample may be used for these tests.*

### 5.2 Total content and migration of formaldehyde

When tested in accordance with BS EN ISO 14184-1, textile components of children's beds shall not contain free or hydrolyzed formaldehyde in excess of 30 mg/kg.

When tested in accordance with BS EN 717-2 and BS EN 1084, wooden components of children's beds shall not release formaldehyde in excess of 80 mg/kg.

## 6 Thermal hazards

### 6.1 General

When curtains or textiles are supplied that surround the sleeping surface of the child's bed, they shall conform to 6.2, 6.3 and 6.4.

### 6.2 Flash effect

When tested in accordance with BS EN 1103, there shall be no flash effect.

### 6.3 Flame propagation

When tested in accordance with BS EN 71-2:2006, 4.4, the maximum rate of spread of flame of textile materials or coated textile materials shall be 30 mm/sec.

## 6.4 Melting behaviour of materials

When tested in accordance with BS EN 71-2:2006, 4.4, if the sample has a rate of spread of flame greater than 20 mm/s, there shall be no flaming debris or molten drips.

*NOTE* A separate sample may be used for the tests in 6.2, 6.3 and 6.4.

## 7 Mechanical hazards – gaps and openings

### 7.1 Entrapment of head and neck

#### 7.1.1 Completely bound openings

When tested in accordance with 7.1.3, completely bound openings that allow the hip probe to pass completely through shall also allow the head probe to pass completely through the opening.

Completely bound openings that allow the head probe to pass completely through shall conform to the requirement for partially bound, V and irregular shaped openings (see 7.1.2).

#### 7.1.2 Partially bound, V and irregular shaped openings

Partially bound, V and irregular shaped openings shall be constructed so that, when tested in accordance with 7.1.4:

- a) portion B of the V and irregular shaped openings template does not enter the opening; or
- b) the apex of portion A of the V and irregular shaped openings template contacts the base of the opening.

#### 7.1.3 Test for completely bound openings

**7.1.3.1** Insert the hip probe (see 4.5.2) with the highest force possible up to 30 N into completely bound openings.

**7.1.3.2** If the hip probe passes completely through the opening, then insert the head probe (see 4.5.3) into the completely bound opening with a force of up to 5 N.

#### 7.1.4 Test for partially bound, V and irregular shaped openings

**7.1.4.1** Position the B portion of the V and irregular shaped openings template (see 4.5.4) between and perpendicular to the boundaries of the opening (see Figure 14 or Figure 15 as appropriate).

**7.1.4.2** If the V and irregular shaped openings template can be inserted to a depth greater than the thickness of the template (45 mm), apply the A portion of the V and irregular shaped openings template, so that its centre line is in line with the centre line of the opening. Ensure that the plane of the test template is parallel and applied in line with the opening (see Figure 16). Insert the V and irregular shaped openings template along the centre line of the opening until its motion is arrested by contact with the boundaries of the opening.

Figure 14 Method of insertion of portion B

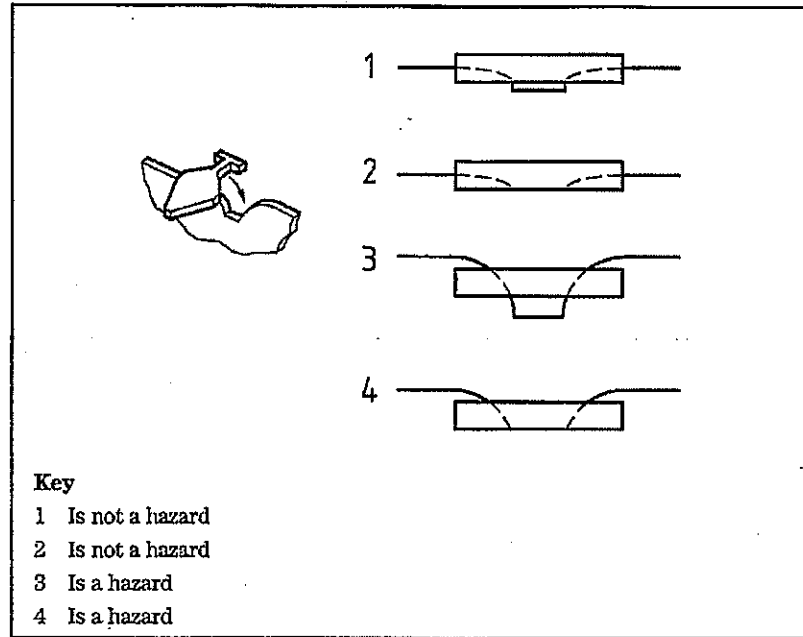

Figure 15 Method of insertion of portion B

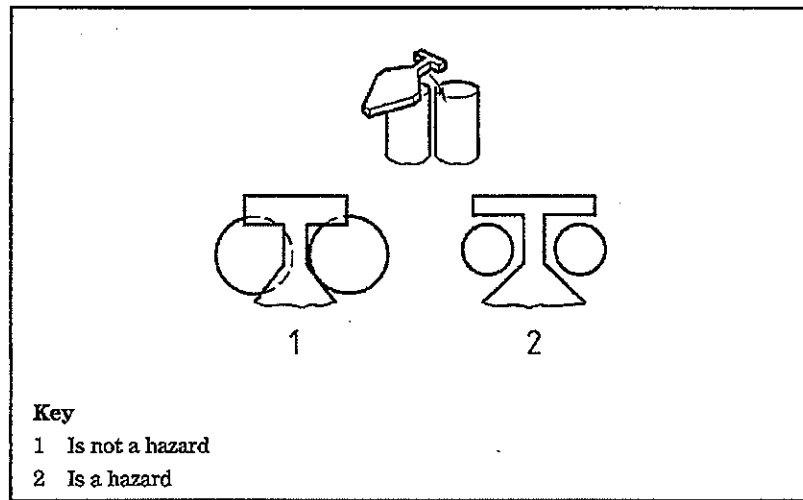
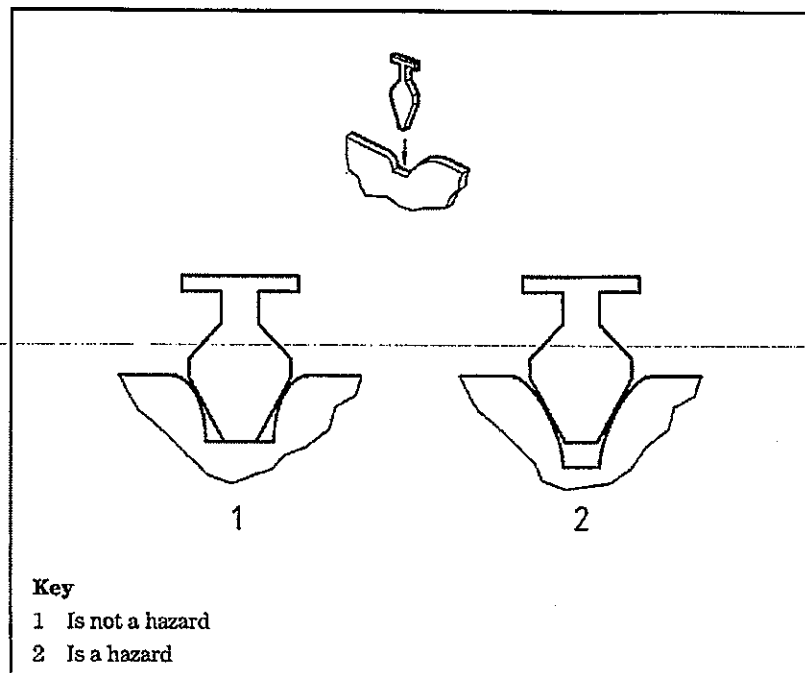

Figure 16 Method of insertion of portion A



## 7.2 Entrapment of fingers

### 7.2.1 Requirements

**7.2.1.1** When tested in accordance with 7.2.2.1, there shall be no openings between 7 mm and 12 mm, unless the depth of penetration is less than 10 mm (see 7.2.2.2).

**7.2.1.2** When tested in accordance with 7.2.2.3, there shall be no openings in mesh or flexible materials that allow the finger probe for mesh to penetrate to the 7 mm diameter section.

### 7.2.2 Test

**7.2.2.1** Mount the 7 mm probe with hemispherical end (see 4.5.5) on the device for exerting force, so that the end can be presented to the opening being tested. Insert the probe with an applied force of up to 30 N into any accessible opening in any possible orientation.

**7.2.2.2** If the 7 mm probe enters 10 mm or more, mount the 12 mm probe with hemispherical end (see 4.5.5) on the device for exerting force and insert with an applied force of up to 5 N into any accessible opening in any possible orientation.

**7.2.2.3** Mount the probe (see 4.5.6) with conical end on the device for exerting force, so that the conical end can be presented to the opening being tested. Insert the probe with an applied force of up to 30 N into the openings in mesh and flexible materials.

## **7.3 Entrapment in bed base or between bed base and other structures**

### **7.3.1 Requirements**

**7.3.1.1** When tested in accordance with 7.3.2.1, the 60 mm cone shall not pass between any two adjacent slats of the bed base.

**7.3.1.2** When tested in accordance with 7.3.2.2, the 85 mm conical probe shall not pass between the springs or wire of a bed base.

**7.3.1.3** When tested in accordance with 7.3.2.3, the 25 mm diameter conical probe shall not pass between the bed edge or head/foot boards and bed base or other components.

### **7.3.2 Test**

**7.3.2.1** Mount the 60 mm diameter conical probe (see 4.5.7) on the device for exerting force, so that the conical end can be presented to the opening being tested. Insert the probe with a force up to 30 N, between two adjacent slats of the bed base.

**7.3.2.2** Mount the 85 mm diameter conical probe (see 4.5.7) on the device for exerting force. Insert the 85 mm probe, with a force up to 30 N, into any openings between the springs or wire of a bed base.

**7.3.2.3** Mount the 25 mm diameter conical probe (see 4.5.7) on the device for exerting force. Insert the 25 mm probe with a force up to 30 N, between the bed edge or head/foot boards and bed base or other components.

## **8 Mechanical hazards – folding**

### **8.1 Requirements**

#### **8.1.1 Incomplete deployment**

Children's beds that have folding components shall have at least one lock that engages automatically when they are deployed for use.

When tested in accordance with 8.2, the folding components shall not fold or detach.

#### **8.1.2 Unintentional release of folding mechanisms**

Children's beds that have folding components shall conform to one of the following before and after testing in accordance with 8.3:

- a) folding is only possible when two independent locks are operated simultaneously by separate actions; or
- b) there are two or more automatically engaging locks that cannot be released by one single action; or
- c) folding involves two consecutive actions, the first of which is maintained while the second is being carried out.

### **8.2 Test for automatic locking mechanism**

With only the automatic locking mechanism(s) engaged or one automatic locking mechanism engaged, apply a force of 200 N to any part of the child's bed except the locking release mechanism.

### **8.3 Test for folding mechanism**

Unfold and fold the folding components of the child's bed 300 times.

## **9 Mechanical hazards – crushing and shearing**

When the child's bed is assembled for use, there shall be no accessible openings or gaps between components that can close to less than 12 mm, unless the openings or gaps are always less than 3 mm, as a result of:

- a) the mass or movement of the child's bed; or
- b) the movement of body weight by the child using the child's bed; or
- c) the application of an external force (either by another child or adult or by a powered mechanism).

If the child's bed is adjustable, it shall not be possible to adjust it without the use of a tool.

## **10 Mechanical hazards – protruding parts**

### **10.1 Requirement**

When tested in accordance with 10.2, the spherical mass shall not be supported by means of the ball chain loop on any protruding part accessible from inside the child's bed.

### **10.2 Test**

**10.2.1** Hold the spherical mass in one hand and, with the other hand, create an open loop in the ball chain (see 4.5.8).

**10.2.2** Place the ball chain loop over any potential protruding part accessible from the sleeping surface of the child's bed. Lower the weight until either the ball chain loop is supported and the weight hangs freely from the protruding part or the ball chain loop slides over the protruding part.

## 11 Mechanical hazards – entanglement in cords, ribbons and similar parts

### 11.1 Requirements

When tested in accordance with 11.2, cords, ribbons and similar parts that are accessible from inside the child's bed shall have a maximum free length of 220 mm. Where cords, ribbons and similar parts are attached to the child's bed either together or within 80 mm of each other, the combined length from one loose end of one cord, ribbon or similar part to the loose end of the other cord, ribbon or similar part shall be a maximum of 360 mm.

Loops shall have a maximum peripheral dimension of 360 mm.

Monofilament threads shall not be used as cords, ribbons and similar parts, loops or as sewing threads.

*NOTE* These requirements also apply to furnishings supplied with the child's bed.

### 11.2 Test

11.2.1 Measure the length of a cord, ribbon or similar part from the fixing point on the child's bed or furnishing to the free end of the cord, ribbon or similar part while applying a 25 N tensile force to the cord, ribbon or similar part.

11.2.2 Measure the peripheral dimension of a loop while applying a 25 N tensile force to the loop.

## 12 Mechanical hazards – small parts

### 12.1 Requirement

When tested in accordance with 12.2 and 12.3, any component or part of a component that is removed, whether intended to be removed without the use of a tool or not, shall not fit entirely within the small parts cylinder (see 4.5.9).

### 12.2 Torque test

12.2.1 Attach a clamp to any component on the child's bed that a child could grip, taking care not to damage the attachment mechanism or body of the component.

12.2.2 Apply a torque gradually to the component within a period of 5 s in a clockwise direction until either:

- a) a rotation of 180° from the original position has been attained; or
- b) a torque of 0.34 Nm is reached.

12.2.3 Apply the maximum rotation or required torque for 10 s.

12.2.4 Allow the component to return to a relaxed condition and repeat the procedure in an anticlockwise direction.



**12.2.5** Where projections, components or assemblies are rigidly mounted on an accessible rod or shaft designed to rotate together with the projections, components or assemblies, clamp the rod or shaft to prevent rotation.

**12.2.6** If a component which is attached by a screw thread becomes loosened during application of the required torque, continue to apply the torque until:

- a) the specified torque is exceeded;
- b) the component disassembles; or
- c) it becomes apparent that the component will not disassemble.

**12.2.7** Check whether any component or part of a component that becomes removed fits wholly within the small parts cylinder (see 4.5.9).

### 12.3 Tensile test

**12.3.1** The same components as tested in 12.2.

**12.3.2** Attach the clamp to any component that a child could grip taking care not to damage the attachment mechanism or body of the component.

**12.3.3** Apply a tensile force of up to 90 N to the component within a period of 5 s and maintain for 10 s, at a sufficiently slow rate to ensure that negligible dynamic force is applied.

**12.3.4** Check whether the component or any part of a component that is removed fits wholly within the small parts cylinder (see 4.5.9).

## 13 Mechanical hazards – suffocation

### 13.1 Self adhesive labels and decals

Self adhesive labels and decals shall not be applied to the inside of the head and foot boards of a child's bed.

### 13.2 Packaging materials

Any plastic covering used as packaging that does not conform to BS EN 71-1 shall be conspicuously marked with the following statement:

**TO AVOID DANGER OF SUFFOCATION REMOVE PLASTIC COVER BEFORE USING THIS ARTICLE. THIS COVER SHALL BE DESTROYED OR KEPT AWAY FROM CHILDREN.**

*NOTE* The statement may be expressed in different words providing they clearly convey the same information.

## **14 Mechanical hazards – edges and protruding parts**

### **14.1 General**

Edges and protruding parts accessible during normal use shall be rounded or chamfered; all other edges and protruding parts shall be free from burrs and sharp edges.

### **14.2 Edges on tubes**

When the child's bed is assembled for use, any accessible external and internal edges on open ended tubes shall have a minimum radius of 2 mm or be chamfered.

Open ended tubes with a wall thickness of less than 4 mm shall be closed, covered or capped.

## **15 Mechanical hazards – points and wires**

There shall be no sharp points, e.g. staples, nails or screws, protruding from any part of the child's bed.

Staples shall not be proud of the surface.

## **16 Mechanical hazards – inadequate structural integrity – materials and fastenings**

### **16.1 Materials**

Wood and wood-based material shall be visually free of infestation.

### **16.2 Connecting screws for direct fastening**

Connecting screws for direct fastening, e.g. self tapping screws, shall not be used for the assembly of any component that is designed to be removed or loosened when dismantling the child's bed for transportation, storage or conversion from a cot.

### **16.3 Staples**

Staples shall be loaded in shear.

## 17 Mechanical hazards – inadequate structural integrity – vertical static strength of bed base edges

### 17.1 Requirements

When tested in accordance with 17.2, no part of the child's bed shall break, be damaged or become detached and the child's bed shall still function as intended.

When a safety rail is fitted to a cot bed or toddler bed, the test shall be conducted on both the bed edge and the safety rail.

### 17.2 Test

Position the two bed edge loading pads (see 4.5.10) 300 mm either side of the centre line (M) of the child's bed base edge. Apply a force of 1 200 N simultaneously to each loading pad for  $60\text{ s} \pm 2\text{ s}$  (see Figure 17). If the bed tends to overturn, apply a suitable force to the bed to prevent this.

Figure 17 Vertical static strength test of bed edge

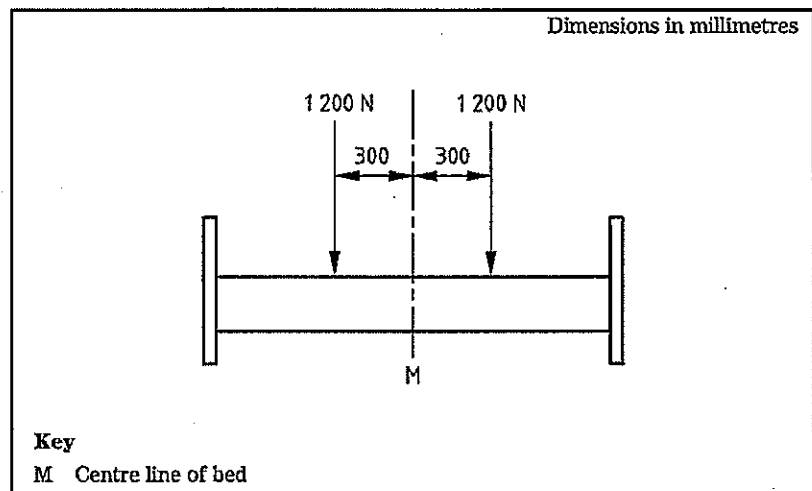

## 18 Mechanical hazards – inadequate structural integrity – vertical impact strength of bed base

### 18.1 Requirement

When tested in accordance with 18.2, no part of the child's bed shall break, be damaged or become detached and the child's bed shall still function as intended.

## 18.2 Test

18.2.1 Place the test mattress (see 4.5.11) flat on the bed base.

18.2.2 Drop the impactor (see 4.5.12) 10 times, allowing it to fall freely, from a height of 180 mm above the bed base onto the mattress, at each of the vertical impact points (see Figure 18).

*NOTE The impactor may be guided by a guide rail.*

18.2.3 In addition to the impact points given in Figure 18, select one further impact point where the bed base appears to be weakest and test this with the impactor.

Figure 18. Vertical impact points

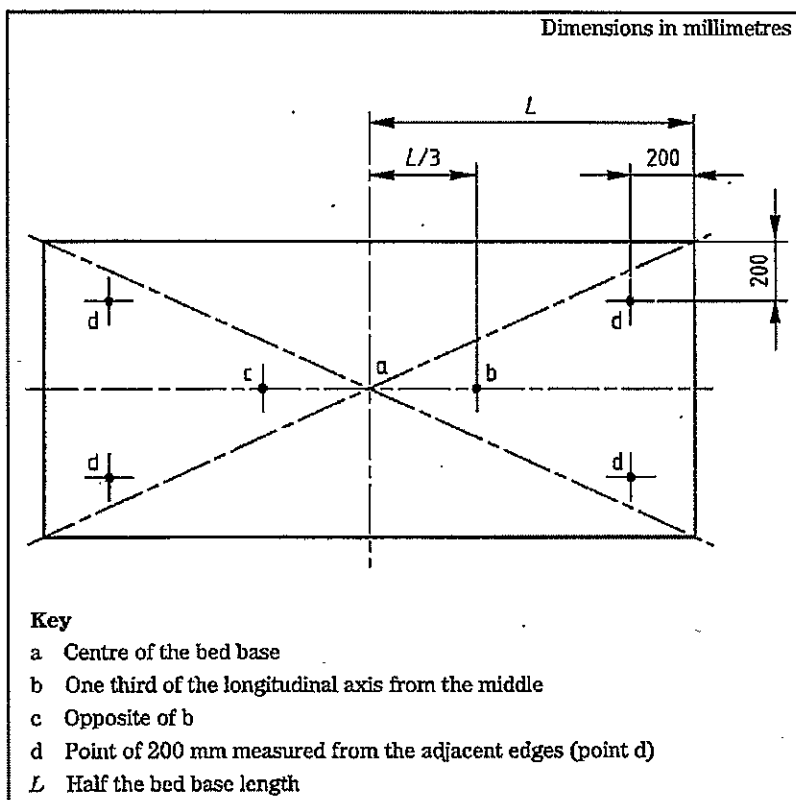

## 19 Mechanical hazards – inadequate structural integrity – durability of bed base

### 19.1 Requirement

When tested in accordance with 19.2, no part of the child's bed shall break, be damaged or become detached and the child's bed shall still function as intended.

## 19.2 Test

**19.2.1** Place the test mattress (see 4.5.11) flat on the bed base.

**19.2.2** Apply a vertical force of 1 000 N downwards with the bed base loading pad (see 4.5.13) in the centre of the bed base and at one point 300 mm from one side and at 300 mm from the adjacent edge (see Figure 19).

**19.2.3** Apply the force 10 000 times for  $2\text{ s} \pm 1\text{ s}$  at each position, at a rate such as to ensure that no excessive heating occurs.

**19.2.4** If the child's bed tends to move during the test, restrict the movement in such a way that it does not affect the test.

Figure 19 Durability of bed base test positions

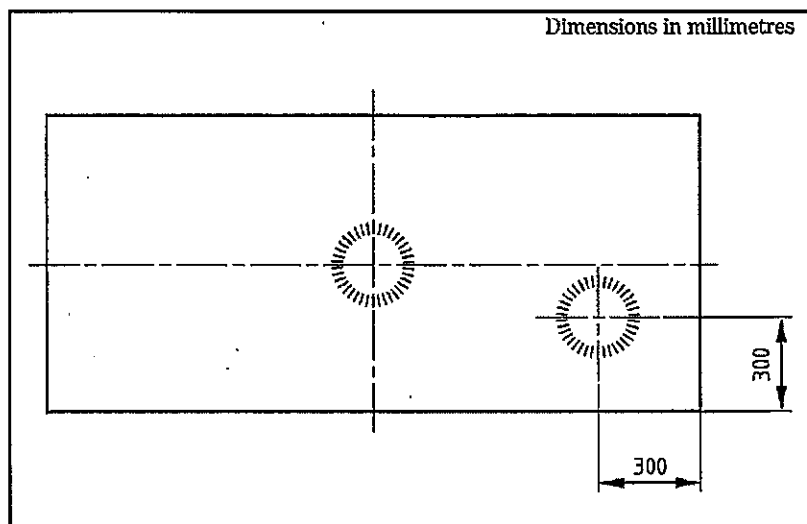

## 20 Mechanical hazards – inadequate structural integrity – durability of bed edge

### 20.1 Requirement

When tested in accordance with 20.2, no part of the child's bed shall break, be damaged or become detached and the child's bed shall still function as intended.

### 20.2 Test

**20.2.1** Mount the naturalistically shaped loading pad (see 4.5.14) on the device for exerting force in such a way that it can pivot in the vertical plane about its transverse axis.

**20.2.2** Apply a force of 1 000 N for 5 000 cycles of  $2\text{ s} \pm 1\text{ s}$  with the naturalistically shaped edge loading pad, on one edge, at the centre of its length, at 200 mm from the edge of the top surface of the test mattress (see 4.5.11), at a rate that does not cause excessive heating.

**20.2.3** If the child's bed tends to move during the test, restrict the movement in such a way that it does not affect the test.

## **21 Mechanical hazards – inadequate structural integrity – strength of head and foot boards**

### **21.1 Requirement**

When tested in accordance with 21.2, the headboard and footboard shall not break, be damaged or loosened, or become detached.

### **21.2 Test**

**21.2.1** Place the legs of the headboard end of the child's bed against stops to prevent the bed moving.

**21.2.2** Gradually apply an inwards force of 300 N over a period of 5 s at the centre of the top edge of the footboard and maintain for 10 s.

**21.2.3** Repeat steps 21.2.1 and 21.2.2 with the footboard.

## **22 Mechanical hazards – inadequate structural integrity – strength of side guards and/or safety rails**

### **22.1 Requirement**

When tested in accordance with 22.2, any integral side guards or safety rails shall not break, be damaged or loosened, or become detached.

### **22.2 Test**

**22.2.1** Place a load on the child's bed sufficient to prevent overturning.

**22.2.2** Apply the following forces separately to the centre and to one end of the side guard or safety rail using the bed edge loading pad (see 4.5.10), at the point most likely to cause failure:

- a) vertical upwards force of 150 N;
- b) vertical downwards force of 150 N;
- c) horizontal force of 300 N outwards;
- d) horizontal force of 300 N inwards.

**22.2.3** Apply each force for  $30\text{ s} \pm 2\text{ s}$ , for a total of 10 times at each position, and at a sufficiently slow rate to ensure that negligible dynamic force is applied.

**22.2.4** Where the construction or fastening of the side guard or safety rail differs between ends, test both ends.

## 23 Mechanical hazards – inadequate structural integrity – strength of top rails for four poster features

### 23.1 Requirement

When tested in accordance with 23.2, the top rails of any four poster feature shall not break, be damaged or loosened, or become detached.

### 23.2 Test

23.2.1 Place a load on the child's bed with an additional four poster feature sufficient to prevent overturning.

23.2.2 Apply to the following a force of 600 N for  $60\text{ s} \pm 2\text{ s}$  by means of a 50 mm wide webbing strap, at a sufficiently slow rate to ensure that negligible dynamic force is applied:

- to the centre line (M) of the top side rail (see Figure 20);
- on the other top side rail;
- on the centre line (N) of one top end rail (see Figure 21); and
- on the other top end rail.

Figure 20 Loading of top side rail

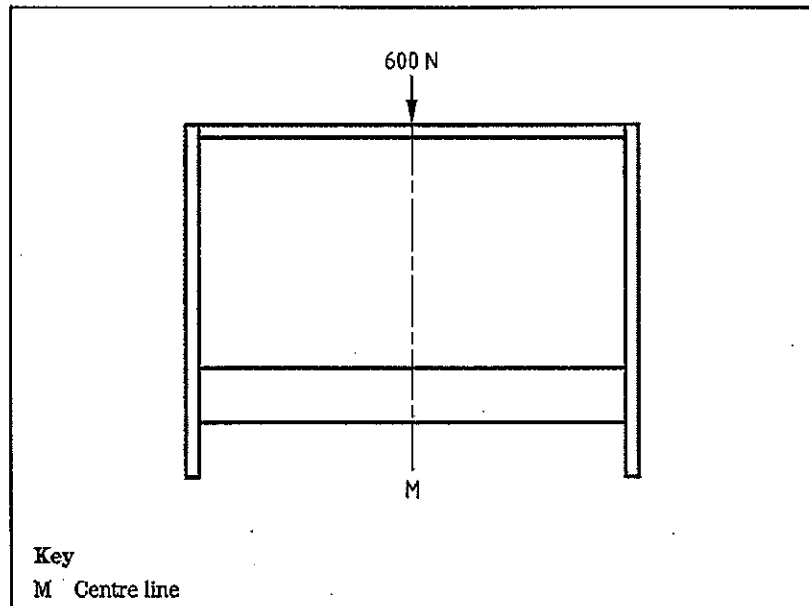
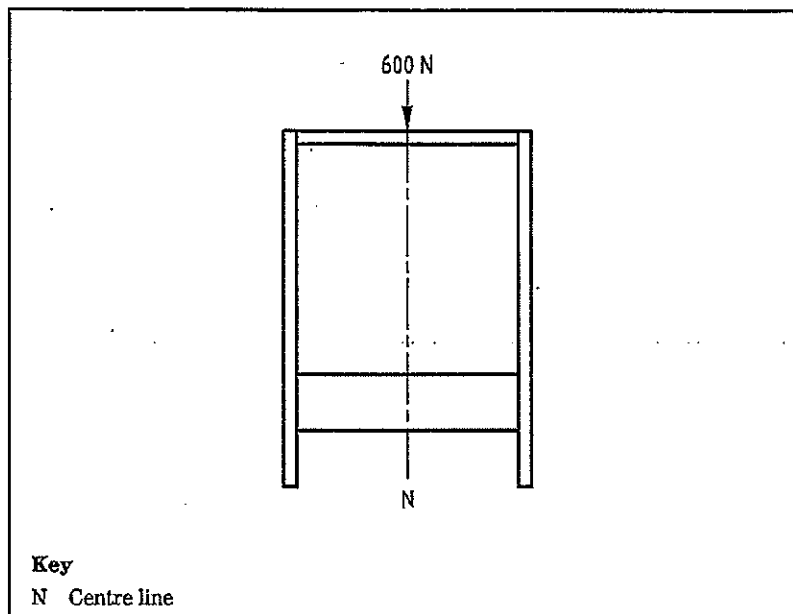

Figure 21 Loading of top end rail



## 24 Product information

### 24.1 Marking

Children's beds shall be permanently marked with the following:

- the number and year of this British Standard, i.e. BS 8509:2008<sup>1)</sup>;
- the name, registered trade name or registered trade mark of either the manufacturer, distributor or retailer.

Markings shall be conspicuous and legible, and labels shall be securely attached.

### 24.2 Durability of marking

#### 24.2.1 Requirement

After testing in accordance with 24.2.2, any permanent label and/or marking shall not be removed and markings shall be legible.

#### 24.2.2 Test

Manually rub any permanent label and/or marking with a water dampened cloth for 20 s.

### 24.3 Purchase information

The following information shall be provided at the point of sale:

- Marking BS 8509:2008 on or in relation to a product represents a manufacturer's declaration of conformity, i.e. a claim by or on behalf of the manufacturer that the product meets the requirements of the standard. The accuracy of the claim is solely the claimant's responsibility. Such a declaration is not to be confused with third-party certification of conformity.



- a) the age range of the child for which the child's bed is intended;
- b) the size of the mattress to be used with the child's bed, if one is not supplied;
- c) that the child's bed conforms to BS 8509:2008 <sup>2)</sup>;
- d) means of identifying the product e.g. model number.

## 24.4 Instructions for use

### 24.4.1 General

Instructions for the safe use of the child's bed shall be provided and shall be headed "IMPORTANT! KEEP FOR FUTURE REFERENCE" in letters not less than 5 mm high.

### 24.4.2 Warnings

The instructions shall contain the following warnings:

**WARNING.** Do not place this child's bed near heat sources, windows and other furniture.  
**WARNING.** Do not use this child's bed if any part is broken, torn or missing.

### 24.4.3 Additional information

The instructions shall contain the following additional information:

- a) that the child's bed conforms to BS 8509:2008 <sup>2)</sup>;
- b) the registered trade name or trademark of the manufacturer, distributor, importer or retailer;
- c) means of identification, e.g. model number;
- d) the age range of the child for which the child's bed is intended;
- e) the size of the mattress to be used with the child's bed;
- f) if applicable, an assembly drawing, list and description of all parts and tools required for assembly, and a diagram of the bolts and other fastenings required;
- g) a statement that all assembly fittings should always be tightened properly and checked periodically;
- h) cleaning and maintenance recommendations;
- i) that children are likely to play, bounce, jump and climb on beds, therefore the child's bed should not be placed too close to other furniture or windows, and should be placed either tight to any wall or have a gap of 300 mm between the wall and the side of the bed;
- j) where luminaires are included as part of the child's bed, a warning about electric shock and/or heat sources;
- k) a recommendation that any additional or replacement parts are obtained from the manufacturer or distributor.

<sup>2)</sup> Marking BS 8509:2008 on or in relation to a product represents a manufacturer's declaration of conformity, i.e. a claim by or on behalf of the manufacturer that the product meets the requirements of the standard. The accuracy of the claim is solely the claimant's responsibility. Such a declaration is not to be confused with third-party certification of conformity.

## BSI – British Standards Institution

BSI is the independent national body responsible for preparing British Standards. It presents the UK view on standards in Europe and at the international level. It is incorporated by Royal Charter.

### Revisions

British Standards are updated by amendment or revision. Users of British Standards should make sure that they possess the latest amendments or editions.

It is the constant aim of BSI to improve the quality of our products and services. We would be grateful if anyone finding an inaccuracy or ambiguity while using this British Standard would inform the Secretary of the technical committee responsible, the identity of which can be found on the inside front cover.

Tel: +44 (0)20 8996 9000 Fax: +44 (0)20 8996 7400

BSI offers members an individual updating service called PLUS which ensures that subscribers automatically receive the latest editions of standards.

### Buying standards

Orders for all BSI, international and foreign standards publications should be addressed to Customer Services. Tel: +44 (0)20 8996 9001

Fax: +44 (0)20 8996 7001 Email: [orders@bsigroup.com](mailto:orders@bsigroup.com)

You may also buy directly using a debit/credit card from the BSI Shop on the Website <http://www.bsigroup.com/shop>.

In response to orders for international standards, it is BSI policy to supply the BSI implementation of those that have been published as British Standards, unless otherwise requested.

### Information on standards

BSI provides a wide range of information on national, European and international standards through its Library and its Technical Help to Exporters Service. Various BSI electronic information services are also available which give details on all its products and services. Contact the Information Centre. Tel: +44 (0)20 8996 7111 Fax: +44 (0)20 8996 7048 Email: [info@bsigroup.com](mailto:info@bsigroup.com)

Subscribing members of BSI are kept up to date with standards developments and receive substantial discounts on the purchase price of standards. For details of these and other benefits contact Membership Administration. Tel: +44 (0)20 8996 7002 Fax: +44 (0)20 8996 7001 Email: [membership@bsigroup.com](mailto:membership@bsigroup.com)

Information regarding online access to British Standards via British Standards Online can be found at <http://www.bsigroup.com/BSOL>.

Further information about BSI is available on the BSI website at <http://www.bsigroup.com>.



BSI Group Headquarters  
389 Chiswick High Road,  
London W4 4AL, UK  
Tel +44 (0)20 8996 9001  
Fax +44 (0)20 8996 7001  
[www.bsigroup.com/standards](http://www.bsigroup.com/standards)

### Copyright

Copyright subsists in all BSI publications. BSI also holds the copyright, in the UK, of the publications of the international standardization bodies. Except as permitted under the Copyright, Designs and Patents Act 1988 no extract may be reproduced, stored in a retrieval system or transmitted in any form or by any means – electronic, photocopying, recording or otherwise – without prior written permission from BSI.

This does not preclude the free use, in the course of implementing the standard, of necessary details such as symbols, and size, type or grade designations. If these details are to be used for any other purpose than implementation then the prior written permission of BSI must be obtained.

Details and advice can be obtained from the Copyright & Licensing Manager.  
Tel: +44 (0)20 8996 7070 Email: [copyright@bsigroup.com](mailto:copyright@bsigroup.com)