

Code of practice for

Design of concrete structures for retaining aqueous liquids

UDC 624.953:621.642.3.031:691.32:614.8

Committees responsible for this British Standard

The preparation of this British Standard was entrusted by the Civil Engineering and Building Structures Standards Committee (CSB/-) to Technical Committee CSB/60, upon which the following bodies were represented:

Department of the Environment (Property Services Agency)
Health and Safety Executive
Institution of Civil Engineers
Institution of Structural Engineers
Water Authorities Association

This British Standard, having been prepared under the direction of the Civil Engineering and Building Structures Standards Committee, was published under the authority of the Board of BSI and comes into effect on 30 October 1987.

© BSI 11-1998

The following BSI references relate to the work on this standard:
Committee reference CSB/60
Draft for comment 86/12222 DC

ISBN 0 580 16134 X

Amendments issued since publication

Amd. No.	Date of issue	Comments

Contents

	Page
Committees responsible	Inside front cover
Foreword	iii
<hr/>	
Section 1. General	
1.1 Scope	1
1.2 Field of application	1
1.3 Symbols	1
1.4 Operational safety	1
1.5 Statutory requirements	1
<hr/>	
Section 2. Design: objectives and general recommendations	
2.1 Design objectives	2
2.2 Structural design	2
2.3 Loads	3
2.4 Analysis of walls and junctions	3
2.5 Site conditions	4
2.6 Causes and control of cracking	4
2.7 Design life and serviceability	5
2.8 Specification	7
2.9 Operational safety considerations	7
<hr/>	
Section 3. Design and detailing: reinforced concrete	
3.1 General	8
3.2 Design	8
<hr/>	
Section 4. Design and detailing: prestressed concrete	
4.1 General	10
4.2 Basis of design	10
4.3 Cylindrical prestressed concrete structures	10
4.4 Other prestressed concrete structures	10
<hr/>	
Section 5. Design, detailing and workmanship of joints	
5.1 General	11
5.2 Types of joint	11
5.3 Movement joints	11
5.4 Construction joints	13
5.5 Temporary open sections	14
5.6 Joints in ground slabs	14
5.7 Joints in walls	14
5.8 Joints in roofs	14
<hr/>	
Section 6. Concrete: specification and materials	
6.1 General	16
6.2 Materials	16
6.3 Mix proportions	16
6.4 Workability	16
6.5 Surface finish of concrete	16
6.6 Blinding layer	16
6.7 Pneumatically applied mortar	16
<hr/>	
Section 7. Specification and workmanship: reinforcement	
7.1 General	17
7.2 Special reinforcement	17

	Page
Section 8. Specification and workmanship: prestressing tendons	
8.1 General	18
Section 9. Inspection and testing of the structure	
9.1 General	19
9.2 Testing of structures	19
9.3 Testing of roofs	19
Appendix A Calculation of minimum reinforcement, crack spacing and crack widths in relation to temperature and moisture effects	20
Appendix B Calculation of crack widths in mature concrete	26
Appendix C Jointing materials	27
Appendix D Bibliography	30
Figure 5.1 — Examples of movement joints	15
Figure A.1 — Surface zones: walls and suspended slabs	21
Figure A.2 — Surface zones: ground slabs	22
Figure A.3 — Restraint factor R for various wall and floor slab placing sequences	25
Table 3.1 — Allowable steel stresses in direct or flexural tension for serviceability limit states	9
Table 5.1 — Design options for control of thermal contraction and restrained shrinkage	13
Table A.1 — Factors for the calculation of minimum reinforcement for crack distribution and crack spacing	21
Table A.2 — Typical values of T_1 for OPC concretes, where more particular information is not available	24
Table A.3 — Influence of slab proportions on the centreline restraint factor	26
Publications referred to	Inside back cover

Foreword

This British Standard has been prepared under the direction of the Civil Engineering and Building Structures Standards Committee. It replaces BS 5337, which is withdrawn.

Following the withdrawal of CP 114 the alternative method of design allowed in BS 5337 has been omitted in this British Standard. Secondly, the withdrawal of CP 110 and its replacement by BS 8110 have led to the updating of this code to align with BS 8110. One important change is that the crack width equations have been modified to align with the recommendations of BS 8110 and now include a crack width equation for direct tension. Other changes include a more logical arrangement of objectives and general recommendations for design, the introduction of a restraint factor, the introduction of recommendations for partially prestressed concrete structures, improved recommendations for joints, updating of guidance on jointing materials, an elaboration of the recommendations for concrete and reinforcement (including special reinforcement), and a revision of the inspection and testing recommendations for the structure.

For the first time in a British Standard civil engineering design code the designer is recommended to consider operational safety and to provide appropriately at the design stage.

It has been assumed in the drafting of this code that the design of liquid-retaining reinforced and prestressed concrete structures is entrusted to chartered civil or structural engineers experienced in the use of reinforced or prestressed concrete, and that site construction is carried out under the direction of a competent person.

This code, which is a type 1¹⁾ design code, has been prepared by a Technical Committee consisting of chartered engineers nominated by the organizations represented (see the back cover). The members of the Drafting Panel, convened by the Institution of Structural Engineers, were as follows.

Mr R D Anchor B Sc, C Eng, F I Struct E, F I C E Chairman

Mr A H Allen M A (Cantab), B Sc, C Eng, F I Struct E, F I C E

Professor B P Hughes B Sc(Eng), D Sc, Ph D, C Eng, F I Struct E,
M I C E

Mr D W Quinion B Sc(Eng), C Eng, F I Struct E, F I C E

Mr E H Thorpe C Eng, M I Struct E

Mr R J W Milne B Sc Secretary

The work of the Drafting Panel was overseen by the Steering Group from the Technical Committee, whose members included the following.

Mr C J Evans M A(Cantab), F Eng, F I Struct E, F I C E, F I W E S Chairman

Mr H B Gould C Eng, F I Struct E, F I C E

Mr I T Millar B Sc, C Eng, M I C E

Mr E M O'Leary B E, C Eng, F I Struct E, F I C E, M I H T

Mr K Rowe C Eng, M I C E, F B I M, M I W E S

NOTE The numbers in square brackets used throughout the text of this standard relate to the bibliographic references given in appendix D.

¹⁾ Type 1 codes are defined in PD 6501-1 as "those detailing professional knowledge or practices".

A British Standard does not purport to include all the necessary provisions of a contract. Users of British Standards are responsible for their correct application.

Compliance with a British Standard does not of itself confer immunity from legal obligations.

Summary of pages

This document comprises a front cover, an inside front cover, pages i to iv pages 1 to 30, an inside back cover and a back cover.

This standard has been updated (see copyright date) and may have had amendments incorporated. This will be indicated in the amendment table on the inside front cover.

Section 1. General

1.1 Scope

This British Standard provides recommendations for the design and construction of normal reinforced and prestressed concrete structures used for the containment or exclusion of aqueous liquids. The term “liquid” in this code includes any contained or excluded aqueous liquids but excludes aggressive liquids. The code does not cover dams, pipes, pipelines, lined structures, or the damp-proofing of basements. The term “structure” is used herein for the vessel that contains or excludes the liquid, and includes tanks, reservoirs, and other vessels.

NOTE 1 The design of structures of special form or in unusual circumstances is a matter for the judgement of the designer.

NOTE 2 The titles of the publications referred to in this standard are listed on the inside back cover.

1.2 Field of application

This British Standard applies particularly to UK conditions, and although the principles are applicable to design in other parts of the world, the designer should take account of local conditions, particularly variations in climate and the possibility of earthquakes, which have not been considered for UK conditions. Consideration has been given to the storage of liquids at ambient temperatures or at temperatures up to approximately 35 °C such as are found in swimming pools and industrial structures.

Recommendations are given for structures in aggressive soils and for structures in areas liable to settlement and subsidence. No recommendations have been made for the effect of any dynamic forces nor for the effect of ice formation on the structure, and the designer should refer to specialist literature for information.

1.3 Symbols

For the purposes of this British Standard the symbols given in BS 8110-1:1985 apply.

1.4 Operational safety

The code includes recommendations for design to provide for operational safety.

1.5 Statutory requirements

Designers should check compliance with any statutory requirements.²⁾

²⁾ Reference should be made to the Reservoirs Act 1975 for structures that have a capacity of more than 25 000 m³.

Section 2. Design: objectives and general recommendations

2.1 Design objectives

The purpose of design is the achievement of acceptable probabilities that the structure being designed will not become unfit in any way for the use for which it is intended. This code provides for a method of design based on limit state philosophy that is generally in accordance with the methods employed in BS 8110. Structural elements that are not part of the liquid-retaining structure should be designed in accordance with BS 8110.

2.2 Structural design

2.2.1 Limit state recommendations

The design of the whole structure and all individual members should be in accordance with the recommendations given in BS 8110 as modified by the recommendations of this code. When all relevant limit states are considered, the design should lead to an adequate degree of safety and serviceability.

It is recommended that the size of the elements and the amounts of reinforcement are assessed on the basis of the serviceability crack width limit state, and that other limit states, including the ultimate limit states, are checked.

2.2.2 Ultimate limit states (ULS)

The partial safety factor, γ_f , for retained liquid loads should be taken as 1.4 (as given in Table 2.1 of BS 8110-1:1985) for load combinations 1 and 2 and as 1.2 for load combination 3, as appropriate.³⁾

2.2.3 Serviceability limit states (SLS)

2.2.3.1 General. The partial safety factor, γ_f , for all loads should be taken as unity as implied in 3.3 of BS 8110-2:1985.

2.2.3.2 Flotation. A structure subject to groundwater pressure should be designed to resist flotation. The deadweight of the empty structure with any anchoring devices should provide a safety factor of not less than 1.1 against uplift pressures during construction and in service. A factor of 1.1 should be used only where the maximum groundwater level can be assessed accurately; otherwise the factor should be assessed by the designer. The uplift may be reduced by:

- a) providing effective drainage to prevent a build-up of external water as far as local conditions permit;

- b) providing pressure relief devices discharging into the vessel (where the entry of external groundwater is acceptable).

2.2.3.3 Cracking. For the purpose of defining the serviceability crack width limit state, the maximum design surface crack widths for the exposure conditions defined in 2.7.3 should be taken to be the following.

- a) *Reinforced concrete.* The maximum design surface crack widths for direct tension and flexure or restrained temperature and moisture effects are:
 - 1) severe or very severe exposure: 0.2 mm;
 - 2) critical aesthetic appearance: 0.1 mm.

- b) *Prestressed concrete.* Except for the special recommendations for the design of cylindrical prestressed structures (see 4.3), the tensile stress in the concrete should be limited for prestressed concrete structures in accordance with the recommendations of 2.2.3.4.2 of BS 8110-1:1985.

A statically determinate member nominally subjected to axial prestressing should be assumed to have a minimum eccentricity of prestressing of 20 mm or 0.05 times the overall thickness in the plane of bending, whichever is less. For statically indeterminate structures, including cylindrical prestressed structures, this minimum eccentricity recommendation can be ignored.

The required exposure conditions for the surfaces of all members should be clearly defined at the outset of the design process and each member designed in accordance with the crack width limit state recommendations in this section.

Guidance on assumptions and methods that may be used for calculating crack widths are given in 2.6 and appendices A and B.

³⁾ In exceptional circumstances where it is envisaged that the height of the liquid can greatly exceed the height of the wall, factors derived from 2.2.2 of BS 8110-2:1985 should be considered.

2.2.3.4 Deflections. The recommendations for span/effective depth ratios given in BS 8110-1:1985 apply to horizontal members carrying uniformly distributed loads. For a cantilever wall which tapers uniformly away from the support and which is loaded with a triangular pressure, a net reduction factor should be applied to the above ratios if the thickness at the top is less than 0.6 times the thickness at the base. This reduction factor can be assumed to vary linearly between 1.0 and 0.78 where the thickness at the top varies between 0.6 and 0.3 times the thickness at the bottom. In addition, allowance should be made for the significant additional deflection which occurs at the top of the wall due to rotation, if the pressure distribution under the base is triangular or very asymmetrically trapezoidal. Limits for deflections will normally be those for non-liquid-retaining structures since only in exceptional circumstances will deflections be more critical with regard to freeboard, drainage or redistribution of load. Retaining walls should be backfilled in even layers around the structure, the thickness of the layers being specified by the designer. Overcompaction adjacent to the wall should be avoided otherwise large differential deflections (and sliding) of the wall may occur.

At least 75 % of the liquid load should be considered as permanent when calculating deflections.

2.3 Loads

All structures required to retain liquids should be designed for both the full and empty conditions, and the assumptions regarding the arrangement of loading should be such as to cause the most critical effects. Particular attention should be paid to possible sliding and overturning.

Liquid loads should allow for the actual density of the contained liquid and possible transient conditions, e.g. suspended or deposited silt or grit where appropriate. For ultimate limit state conditions, liquid levels should be taken to the tops of walls assuming that the liquid outlets are blocked. For serviceability limit state conditions the liquid level should be taken to the working top liquid level or the overflow level as appropriate to working conditions.

Allowance should be made for the effects of any adverse soil pressures on walls, according to the compaction and/or surcharge of the soil and the condition of the structure during construction and in service. No relief should be given for beneficial soil pressure effects on the walls of containment structures in the full condition. Thermal expansion of a roof should be minimized by reflective gravel or other protection against solar radiation. An example of a critical adverse loading effect occurs when thermal expansion of a roof forces the walls of an empty structure into the surrounding backfill. In this case the passive soil pressure on the walls may be limited by insertion of a thickness of compressible and durable material and/or by providing a sliding joint between the top of the wall and the underside of the roof. This can be either a temporary free sliding joint that is not cast into a fixed or pinned connection until reflective gravel or other solar protective material is placed on the roof, or a permanently sliding joint of assessed limiting friction. Movement of a roof may occur also where there are substantial variations in the temperature of the contained liquid. Where a roof is rigidly connected to a wall this may lead to additional loading in the wall that should be considered in the design. Earth covering on reservoir roofs may be taken as dead load, but due account should be taken of construction loads from plant and heaped earth, which may exceed the intended design load.

2.4 Analysis of walls and junctions

The liquid pressure on plane walls may be resisted by a combination of horizontal and vertical bending moments. An assessment should be made of the proportions of the pressure to be resisted by bending moments in the vertical and horizontal planes. Allowance should also be made for the effects of direct tension in walls induced by flexural action in adjacent walls. Reinforcement should be provided to resist horizontal bending moments at all corners where walls are rigidly joined.

Cylindrical structures may be constructed with a fixed, pinned or sliding joint between the walls and the foundation slab. Allowance should be made for the calculated flexural actions and hoop tensions. Sections should be checked for shear resistance.

2.5 Site conditions

2.5.1 Ground movement

Ground movement leading to displacement and cracking of liquid-retaining structures may cause severe leakage. The designer should therefore consider the possibility of geological faults, mining and other conditions giving rise to foundation conditions where the bearing strata have varying degrees of compressibility. When it is not possible to avoid sites where such conditions occur, the designer should consider adopting one or more of the following measures:

- a) dividing the whole structure into smaller compartments in order to reduce the likely differential movement in each compartment;
- b) providing specially designed joints in the structure to facilitate movement;
- c) using prestressing techniques to act as a safeguard against cracking;
- d) providing flexible sections in service pipes;
- e) in mining areas, providing a form of foundation that will reduce any horizontal forces from ground movement;
- f) providing underfloor drainage to prevent possible uplift pressures on floors and wall bases where groundwater is not considered in the design, for example, where only one compartment of a two-compartment structure is filled and leakage occurs.

Other measures may also be necessary depending on the predicted degree of subsidence.

2.5.2 Aggressive soils and chemical deterioration

Chemical analyses of the soil and groundwater are essential where aggressive substances are suspected. Some waters containing dissolved free carbon dioxide, natural acids or salts may be aggressive, and it will be necessary to take special precautions. Dissolved salts may cause serious deterioration in the concrete and corrosion of the steel. Reference should be made to **6.2** of BS 8110-1:1985 concerning concrete exposed to sulphate or other attack or susceptible to alkali-silica reaction, and for the use of special cements to resist the action of certain aggressive substances. In other and more serious conditions, an impermeable protective coating of a suitable bituminous or other composition may be used on the surface of the concrete.

2.6 Causes and control of cracking

2.6.1 Applied loading effects

Direct or flexural tension in the concrete arising from applied external service loads, from temperature gradients due to solar radiation, or from the containment of liquids at temperatures above ambient, may cause cracking in the concrete. The limitation of cracking from applied loading is dealt with in **2.2.3.3** and in the appropriate design sections. Crack widths arising from flexure and direct tension in mature concrete may be calculated as indicated in appendix B.

2.6.2 Temperature and moisture effects

2.6.2.1 Origins. Changes in the temperature of the concrete and reinforcement and in the moisture content of the concrete cause dimensional changes which, if resisted internally or externally, may crack the concrete. The distribution and width of such cracks can be controlled by reinforcement, together with the provision of movement joints. In this clause, i.e. **2.6.2**, temperature and moisture changes and methods for their control in relation to the particular problems of liquid-retaining structures are considered; it supplements information given in BS 8110-2:1985.

Heat is evolved as cement hydrates, and the temperature will rise for a day or more after casting and then fall towards ambient. Cracking usually occurs at this time while the concrete is still weak. Subsequent lower ambient temperatures and loss of moisture when the concrete is mature will open these cracks, although the loss of moisture at the surface under external drying conditions is usually low. A structure built in the summer but not filled or an external structure standing empty will usually be subjected to greater drops in temperature than the same structure filled. Structures constantly full and protected from climatic effects (e.g. by earth cover, shading or reflective treatment) will have a temperature near that of the liquid stored.

The designer should allow for both the greatest drop in temperature below the peak temperature arising from the heat of hydration and the maximum drying that can be expected, bearing in mind the effects of delays in construction and of conditions that may occur when structures are emptied for maintenance or repair.

2.6.2.2 Methods of control. Cracking arising from temperature and moisture changes in concrete structures can be controlled by reinforcement, by prestress, by movement joints, by temporary open sections closed with subsequent short infill strips, or by a combination of these methods. Cracking arising from minor uneven settlement may also be controlled by the provision of movement joints and by reinforcement or prestress (see **2.5.1**).

In order to minimize and control cracking that may result from temperature and moisture changes in the structure it is desirable to limit the following factors:

- a) the maximum temperature and moisture changes during construction by:
 - 1) using aggregates having low or medium coefficients of thermal expansion and avoiding the use of shrinkable aggregates,
 - 2) using the minimum cement content consistent with the requirements for durability and, when necessary, for sulphate resistance,
 - 3) using cements with lower rates of heat evolution,
 - 4) keeping concrete from drying out until the structure is filled or enclosed,
 - 5) avoiding thermal shock or over-rapid cooling of a concrete surface;
- b) restraints to expansion and contraction by the provision of movement joints (see **5.3**);
- c) restraints from adjacent sections of the work by using a planned sequence of construction or temporary open sections (see **5.5**);
- d) localized cracking within a particular member between movement joints by using reinforcement or prestress;
- e) rate of first filling with liquid (see **9.2**);
- f) thermal shock caused by filling a cold structure with a warm liquid or vice versa.

2.6.2.3 Reinforcement to control restrained shrinkage and thermal movement cracking. The reinforcement referred to in **2.6.2.2** to control cracking arising from restrained shrinkage and thermal movement should be placed in all slabs (floors, walls, roofs) as near to the surface of the concrete as is consistent with the requirement for cover. Prestressed slabs should be provided with reinforcement in any lateral direction in which there is no significant prestress.

The reinforcement should be calculated in accordance with **5.3.3** and appendix A. Except as provided for in option 3 in Table 5.1 and **5.3.3**, the amount of reinforcement in each of two directions at right angles within each surface zone should be not less than 0.35 % of the surface zone cross section, as defined in Figure A.1 and Figure A.2 for deformed grade 460 reinforcement⁴⁾ and not less than 0.64 % for plain grade 250 reinforcement. In wall slabs less than 200 mm in thickness the calculated amount of reinforcement may all be placed in one face. For ground slabs less than 300 mm thick (see **A.2**), the calculated reinforcement should be placed as near to the upper surface as possible consistent with the nominal cover. Bar spacings should generally not exceed 300 mm or the thickness of the section, whichever is the lesser. Where welded fabric⁴⁾ only is used bar spacings should not exceed 1.5 times the thickness of the section.

2.7 Design life and serviceability

2.7.1 General

The life of a completed structure depends on the durability of its components. For a correctly designed structure and good-quality materials and workmanship, the design life of the structure should be between 40 years and 60 years. Some components of the structure (such as jointing materials) have a shorter life than the structural concrete and may require renewal during the life of the structure.

⁴⁾ Deformed grade 460 bars complying with BS 4449 or BS 4461 and high-yield wire fabric complying with BS 4483 having a guaranteed yield or proof stress and guaranteed weld strength.

2.7.2 Maintenance and operation

The completed structure should be inspected regularly. The designer should provide the user with a statement listing the items requiring examination during such maintenance inspections, and stating the recommended frequency of such inspections. The inspection should include examination of the concrete for cracking, leakage, surface deterioration and settlement. Particular attention should be paid to any rust stains that might indicate corrosion of the reinforcement. Any defects should then be corrected. Movement joints should be cleaned and the joint materials replaced if necessary.

The designer should also prepare a schedule of precautions to be taken by the user in order to prevent the structure being damaged or the design life shortened during use. The schedule should be included in the commissioning documentation.

2.7.3 Exposure and appearance

For the purposes of this code, both faces of a liquid-containing or liquid-excluding structural member, together with any internal walls and columns of a containment structure, are to be considered as subject to severe exposure as defined in 3.3.4 of BS 8110-1:1985.

Surfaces subjected to very severe exposure as defined in 3.3.4 of BS 8110-1:1985 should be designed for a maximum design crack width of 0.2 mm (see 2.2.3.3) and concrete cover and mix complying with the recommendations of BS 8110-1:1985, as well as 2.7.6 and 6.3.

Where significant efflorescence and staining of the surface of the structure would be considered to be unacceptable, the recommendations for critical aesthetic appearance should be satisfied (see 2.2.3.3).

2.7.4 Durability

The recommendations in this code for cover, concrete grade, cement content, maximum free water/cement ratio and the means of ensuring a low permeability of the concrete are intended to meet the durability recommendations that correspond generally with the recommendations in Table 3.4 of BS 8110-1:1985 for severe exposure (see 6.3). Consideration should be given to the effect of the liquid to be stored on the durability of all the materials of construction, e.g. concrete, reinforcement or prestressing steel and jointing materials: this is especially pertinent to process liquids and some sewage effluents, although the latter are usually deficient in oxygen and not particularly aggressive. Similar considerations apply to groundwaters (see 2.5.2). Attention is also drawn to the possibility of biological attack, especially on the jointing materials.

The protection afforded by the specified cover and a correctly designed and fully compacted concrete mix is satisfactory for the majority of constructions, but where extended design life is required for a structure, consideration may be given to increasing the cement content (see the next paragraph), increasing the cover (see 2.7.6) or using special reinforcement (see 7.2).

A concrete mix with an increased cement content will provide extra protection for the reinforcement, but a higher cement content will cause more heat of hydration and require extra reinforcement in accordance with appendix A.

2.7.5 Impermeability of the concrete

The concrete should have low permeability. This is important not only for its direct effect on leakage but also because it is one of the main factors influencing durability, resistance to leaching, chemical attack, erosion, abrasion, frost damage and the protection from corrosion of embedded steel. The recommendations in this code for concrete mixes, aggregates, minimum cement content and strength, curing and admixtures generally ensure an adequately impermeable concrete, but it is essential that complete compaction without segregation is obtained on site. In some cases an increased cement and water content may be required in order to obtain adequate workability to ensure complete compaction without increasing the water/cement ratio, but in no case should the maximum cement content be exceeded. Alternatively, adequate workability may be achieved by using a lower water/cement ratio for the same cement content: for this a water-reducing agent is employed.

2.7.6 Cover

The nominal cover of concrete for all steel, including stirrups, links, sheathing, and spacers should be not less than 40 mm. A greater cover may be necessary at a face in contact with aggressive soils (see 2.5.2) or subject to erosion or abrasion. If the nominal cover is increased, crack widths will increase, especially flexural and direct tension cracks in sections less than 300 mm thick.

In thin sections where it is not possible to achieve 40 mm cover, a higher cement content (see 2.7.4) or special reinforcement (see 7.2) may be used to give a normal design life.

2.8 Specification

The designer should consider the following items when preparing the specification for the structure to ensure that the design assumptions for both materials and workmanship are realized during construction:

- a) dimensional tolerances for concrete;
- b) dimensional tolerances for placing reinforcement and prestressing tendons;
- c) a scheme for ensuring the quality of the concrete in the structure in terms both of constituent materials and of batching, mixing, etc.;
- d) a scheme for ensuring the quality of the steel reinforcement and prestressing tendons;
- e) the positions and details of all construction and movement joints;
- f) the requirements for the test for liquid retention or exclusion, and any period during which autogenous healing is permissible.

For the purposes of this code, this clause replaces 2.3 of BS 8110-1:1985.

2.9 Operational safety considerations

2.9.1 Statutory safety requirements

The designer should take account of the safety requirements appropriate to the construction and operation of the structure issued by the Health and Safety Executive [1]. The requirements are available on request from the Health and Safety Executive.

2.9.2 Provision for access

In enclosed structures the provision of access for personnel is required for inspection, cleaning and testing. At least two access hatches should be provided at opposite ends of the structure and at least one in each compartment. The hatches should be of sufficient size to enable personnel wearing breathing apparatus to enter (e.g. 600 mm × 900 mm), and it should be possible to lock the hatches in both the open and closed positions. The designer should also consider providing concrete stairs where access is required into large liquid compartments that are deeper than 2.5 m. It is preferable to provide a platform under an access hatch. Metal ladders, where provided, should be in accordance with class A of BS 4211 and walkways should be in accordance with BS 5395-3. Step irons in accordance with BS 3572 should be provided where appropriate.

2.9.3 Ventilation

Harmful and/or explosive gases may collect in enclosed structures, and provision should be made for adequate ventilation to limit any possible dangerous accumulations to acceptable levels.

2.9.4 Toxic materials

Toxic materials should not be used, except where their toxicity exists only for a short period prior to commissioning.

Section 3. Design and detailing: reinforced concrete

3.1 General

This section gives methods of analysis and design that will in general ensure that the recommendations in section 2 for reinforced concrete structures are met.

3.2 Design

3.2.1 Basis of design

Design and detailing in reinforced concrete should be in accordance with the recommendations given in section 3 of BS 8110-1:1985, except that:

- a) references to section 2 therein should be read in conjunction with section 2 of this code, which takes precedence;
- b) the design ultimate anchorage bond stresses for horizontal bars in sections in direct tension should not be greater than 0.7 times the values obtained from **3.12.8.4** of BS 8110-1:1985;
- c) maximum design crack widths should be calculated in accordance with **3.2.2** of this code, for the exposure conditions described in **2.7.3** and to the limits given in **2.2.3.3**;
- d) **3.1.2** (basis of design for reinforced concrete) of BS 8110-1:1985 does not apply;
- e) for the design of flat slab roofs, the coefficients for the simplified method given in **3.7.2.7** of BS 8110-1:1985 may also be used for analysis at the serviceability limit state, provided that the effective column head diameters are of the maximum size permitted, based on the shortest span framing into the column;
- f) **3.12.2** (joints) of BS 8110-1:1985 is replaced by section 5 of this code;
- g) **3.3.1** (nominal cover), including Table 3.4, of BS 8110-1:1985 is replaced by **2.7.6**;
- h) **3.3.4.1** (exposure conditions: general) of BS 8110-1:1985 is replaced by **2.7.3**;
- i) **3.12.5** (minimum areas of reinforcement in members) of BS 8110-1:1985 is to be read in conjunction with **2.6.2.3** and appendix A.

3.2.2 Crack widths

Methods of calculating crack widths are given in appendix A (which covers the calculation of minimum reinforcement, crack spacing and crack widths in relation to temperature and moisture effects) and appendix B (which describes the calculation of crack widths in mature concrete). The calculated crack width is that crack width that has an acceptable probability of not being exceeded. An occasional wider crack in a completed structure should not necessarily be regarded as evidence of excessive local damage unless other factors, such as leakage or appearance, contribute to its unacceptability.

Compliance with the recommendations for maximum design surface crack width for each class of exposure given in **2.2.3.3** may be achieved by providing adequate reinforcement at suitable spacings to resist the appropriate stresses. The reinforcement provided to control cracking arising from direct tension in the immature concrete may be regarded as forming the whole or a part of the reinforcement required to control cracking arising from direct and flexural tension in the mature concrete. Calculations for the different cases should be carried out as follows.

- a) *Direct tension in immature concrete.* The crack widths arising from restrained shrinkage and heat of hydration movement should be assessed in accordance with appendix A.
- b) *Direct tension in mature concrete.* The crack widths for reinforced concrete members in externally applied direct tension should be assessed in accordance with appendix B or they may be deemed to be satisfactory if the steel stress in service conditions does not exceed the appropriate value in Table 3.1. Tension resulting from seasonal movement of mature concrete should be assessed in accordance with appendix A.

c) *Flexural tension in mature concrete.* The crack widths should be assessed in accordance with appendix B or they may be deemed to be satisfactory if the steel stress in service conditions does not exceed the appropriate value in Table 3.1. The equations in appendix B apply specifically to members in pure flexure and direct tension. When a column or other member is subjected to combined flexural and compressive stresses, or combined flexural and tensile stresses, the calculated flexural strain should be modified to allow for the direct strain before estimating the crack width.

Table 3.1 — Allowable steel stresses in direct or flexural tension for serviceability limit states

Design crack width	Allowable stress	
	Plain bars ^a	Deformed bars ^b
mm	N/mm ²	N/mm ²
0.1	85	100
0.2	115	130

^a Plain grade 250 bars complying with BS 4449.
^b Deformed grade 460 bars complying with BS 4449 or BS 4461 and high-yield wire fabric complying with BS 4483 having a guaranteed yield or proof stress and guaranteed weld strength.

Section 4. Design and detailing: prestressed concrete

4.1 General

This section gives methods of analysis and design that will in general ensure that for prestressed concrete structures the recommendations in section 2 are met.

4.2 Basis of design

Design should be in accordance with the recommendations given in section 4 of BS 8110-1:1985 except where these are at variance with the specific recommendations of this code. In general the design of prestressed concrete members in exposure conditions as defined in 2.7.3 is controlled by the concrete tension limitations for service load conditions, but the ultimate limit state should be checked.

4.3 Cylindrical prestressed concrete structures

The special recommendations for the design of cylindrical concrete structures prestressed vertically and circumferentially are as follows.

- a) The jacking force in the circumferential tendons should not exceed 75 % of the characteristic strength.
- b) The principal compressive stress in the concrete should not exceed $0.33 f_{cu}$.
- c) The temporary vertical moment induced by the circumferential prestressing operation in the partially stressed condition should also be considered. The maximum value of the flexural stress in the vertical direction from this cause may be assumed to be numerically equal to 0.3 times the circumferential compressive stress. Where the tensile stress would exceed 1.0 N/mm^2 , either the vertical prestress should be increased or the circumferential prestress should be built up in stages, with each stage involving a progressive application of prestress from one end of the cylinder.
- d) When the structure is full there should be no resultant tension in the concrete in the circumferential direction, after allowance for all losses of prestress and on the assumption that the top and bottom edges of the wall are free of all restraint.

e) The bending moments in the vertical direction should be assessed on the basis of a restraint equal to one-half of that provided by a pinned foot, when the foot of the wall is free to slide. In other cases where sliding at the foot of the wall is prevented, the moments in the vertical direction should be assessed for the actual degree of restraint at the wall foot. The tensile stress arising from vertical moments should not exceed 1.0 N/mm^2 .

f) Where the structure is to be emptied and filled at frequent intervals, or perhaps left empty for a prolonged period, the structure should be designed so that there is no residual tension in the concrete at any point when the structure is full or empty.

Prestressing wire may be placed outside the walls, provided that it is protected with pneumatic mortar. However in industrial areas or near the sea, where there is a possibility of corrosive penetration of the covering concrete, the cables should preferably be placed within the walls and grouted. Non-bonded tendons may be used provided that they and their anchorages are adequately protected against corrosion.

Cylindrical concrete structures which are prestressed circumferentially and reinforced vertically should comply generally with the recommendations of this clause, except that 4.3 f) may be relaxed to allow tensile stresses not exceeding 1 N/mm^2 . The design for the vertical reinforcement should be in accordance with section 3.

4.4 Other prestressed concrete structures

Class 3 prestressed concrete structures as defined in 2.2.3.4.2 of BS 8110-1:1985 should be designed in accordance with 4.2 and 4.3. In addition, the nominal cover should satisfy the "very severe" exposure conditions given in Table 4.8 of BS 8110-1:1985, and should be not less than 40 mm.

Section 5. Design, detailing and workmanship of joints

5.1 General

Joints in liquid-retaining structures are temporary or permanent discontinuities at sections, and may be formed or induced.

This section describes the types of joint that may be required and gives recommendations for their design and construction. The types of joint are illustrated in Figure 5.1 and are intended to be diagrammatic. Jointing materials are considered in appendix C.

Joints may be used, in conjunction with a corresponding proportion of reinforcement, to control the concrete crack widths arising from shrinkage and thermal changes to within acceptable limits.

5.2 Types of joints

A movement joint (see 5.3) is intended to accommodate relative movement between adjoining parts of a structure, special provision being made to maintain the water-tightness of the joint.

Movement joints may be of the following types.

- a) *Expansion joint*. This has no restraint to movement and is intended to accommodate either expansion or contraction of the concrete.
- b) *Complete contraction joint*. This also has no restraint to movement, but is intended to accommodate only contraction of the concrete.
- c) *Partial contraction joint*. This provides some restraint, but is intended to accommodate some contraction of the concrete.
- d) *Hinged joint*. This allows two structural members to rotate relative to one another with minimal restraint.
- e) *Sliding joint*. This allows two structural members to slide relative to one another with minimal restraint.

A construction joint (see 5.4) is a joint in the concrete introduced for convenience in construction. Measures are taken to achieve subsequent continuity with no provision for further relative movement.

5.3 Movement joints

5.3.1 Need for movement joints

Structures should be provided with movement joints if effective and economic means cannot otherwise be taken to avoid unacceptable cracking. Regard should be paid to the conditions of structures in service. In elevated structures where restraint is small, movement joints may not be required.

The risk of cracking because of overall temperature and shrinkage effects may be reduced by limiting the changes in temperature to which the structure is subjected, as discussed in 2.6.2.

The storage of warm liquids may affect the provision of expansion joints, as may an uninsulated roof slab.

Restraints on free contraction or expansion of the structure should be reduced as far as possible. With long wall bases or slabs founded at or below ground level, restraints can be reduced by the provision of a sliding layer. This can be provided by founding the structure on a flat and smooth layer of site concrete with interposition of some material to break the bond and facilitate movement, provided that friction is not assumed in the design to resist sliding. Structures on piled foundations should be designed to have a sliding layer between the foundations and the superstructure, or the restraint provided by the piles should be considered in the design.

An order of casting slabs that gives temporary free edges in two directions at right angles will help reduce the restraint to free contraction of the immature concrete.

5.3.2 Design and detailing of movement joints

5.3.2.1 General. All movement joints should be designed to accommodate repeated movement of the structure without loss of liquid. The joint should be designed to suit the characteristics of the material available (see appendix C) and should also provide for the exclusion of grit and debris that would prevent the closing of the joint. Liquid pressure on the joint should be adequately resisted. Detailing at places where the joint changes direction or intersects with another joint should be uncomplicated.

5.3.2.2 Expansion joint. At an expansion joint there is complete discontinuity in both reinforcement and concrete. An initial gap should be provided between adjoining parts of the structure to accommodate the expansion or contraction of the structure. Waterstops, joint fillers and joint sealing compounds are essential.

Design of the joint so as to incorporate sliding surfaces is not precluded and may sometimes be advantageous.

5.3.2.3 Complete contraction joint. At a complete contraction joint there is complete discontinuity in both reinforcement and concrete. Cracking in the adjoining parts of the structure is controlled by the spacing of the joints and the corresponding amount of reinforcement required to transmit movements to the adjacent joints.

A joint may be formed either by using stop ends with no initial gap between the concrete or by using a crack inducer (or other means) to reduce the depth of the concrete section by at least 25 %. In the latter case, the restraint to initial contraction of the concrete exerted by the reduced cross section of the concrete at the joint is small and may be neglected. Waterstops are essential, as are joint sealing compounds, where debris may enter the joints. Transfer of shear across the joint can be achieved by the use of dowel bars with one end of the dowel free to slide.

5.3.2.4 Partial contraction joint. A distinction is made between a complete contraction joint and a partial contraction joint in that, while both types have discontinuity in the concrete, a partial contraction joint has a proportion of the reinforcement continuing through the joint.

5.3.2.5 Hinged joint. A hinged joint is a joint that transmits thrust and shearing force, but permits rotation with minimal restraint. A hinged joint may be formed either by completely separating the two elements, placing one element in a groove in the other, or by crossing the reinforcement at the junction of the two elements. In either case the rotation of one element will not transfer moment to the other.

5.3.2.6 Sliding joint. A sliding joint has complete discontinuity in both reinforcement and concrete and allows relative movement in the plane of the joint. The surface of the concrete on the lower component should be flat and smooth so that movement is not restricted. In order to prevent bonding between the two faces, a separating layer or layers of a suitable material should be provided to allow movement to take place.

5.3.3 Spacing of movement joints

The provision of movement joints and their spacing are dependent on the design philosophy adopted, i.e. whether to allow for or restrain shrinkage and thermal contraction in walls and slabs. At one extreme, the designer may exercise control by providing a substantial amount of reinforcement in the form of small diameter bars at close spacing with no movement joints. At the other extreme, the designer may provide closely spaced movement joints in conjunction with a moderate proportion of reinforcement. Between these extremes, control may be exercised by varying the reinforcement and joint spacing, an increase in spacing being compensated for by an increase in the proportion of reinforcement required.

The three main options for the designer are summarized in Table 5.1 as follows.

- a) *In option 1 (design for full restraint)* no contraction joints are provided within the area designed for continuity, and crack widths and spacing are controlled by the reinforcement. Construction joints become part of the crack pattern and have similar crack widths.
- b) *In option 2 (design for partial restraint)* cracking is controlled by the reinforcement, but the joint spacing is such that some of the daily and seasonal movements in the mature slab or structural member are accommodated at the joints, so reducing the amount of movement to be accommodated at the cracks between the joints.
- c) *In option 3 (design for freedom of movement)* cracking is controlled by the proximity of the joints, with a moderate amount of reinforcement provided, sufficient to transmit movement at any cracked section to the adjacent movement joints. Significant cracking between the adjacent movement joints should not occur.

The options given in Table 5.1 are considered in terms of horizontal movement, but vertical movement in walls should also be considered. Two cases are as follows.

- 1) It is possible for horizontal cracks to occur at any free-standing vertical end because of the change in horizontal restraint with respect to height. For bays of any height the vertical strain arising from this warping effect may be taken as approximately half the horizontal strain, and the vertical steel ratio should not be less than the critical ratio, ρ_{crit} .
- 2) The vertical restraint exerted on a newly cast bay at a vertical construction joint may be assumed to develop at a depth of 2.4 m from the free top surface. Thus design for freedom of movement (option 3) may be used for the vertical reinforcement in the top 2.4 m of a lift. Design for partial restraint (option 2) is appropriate for vertical steel below this depth.

The choice of design imposes a discipline on construction. It is desirable to achieve minimum restraint to early thermal contraction of the immature concrete in walls and slabs even though the finished structure may be designed for full continuity. Cracks arising from thermal contraction in a roof supported on columns may be minimized or even prevented if the roof slab is not tied rigidly to the walls during construction.

5.4 Construction joints

The positions of construction joints should be specified by the designer and indicated on the drawings. If there is a need on-site to revise any specified position or to have additional joints the proposed positions should be agreed with the designer.

Full structural continuity is assumed in design at a construction joint. Reinforcement is fully continuous across the joint and the concrete is taken to be as nearly monolithic as possible. Cracking in the concrete member arising from all thermal and load effects is controlled by the use of reinforcement. The designer should specify the following.

The concrete at the joint should be bonded with that subsequently placed against it, without provision for relative movement between the two. Concrete should not be allowed to run to a feather-edge, and vertical joints should be formed against a stop end. Particular care should be taken when forming the joints.

The surface of the first pour should be roughened to increase the bond strength and to provide aggregate interlock. With horizontal joints, the joint surface should be roughened, without disturbing the coarse aggregate particles, by spraying the joint surface, approximately 2 h to 4 h after the concrete is placed, with a fine spray of water and/or brushing with a stiff brush. Vertical joints can be treated similarly, if the use of a retarder on the stop end is authorized, to enable the joint surface to be treated after the stop end has been removed.

Table 5.1 — Design options for control of thermal contraction and restrained shrinkage

Option	Type of construction and method of control	Movement joint spacing	Steel ratio (see note 2)	Comments
1	Continuous: for full restraint	No joints, but expansion joints at wide spacings may be desirable in walls and roofs that are not protected from solar heat gain or where the contained liquid is subjected to a substantial temperature range	Minimum of ρ_{crit}	Use small size bars at close spacing to avoid high steel ratios well in excess of ρ_{crit}
2	Semicontinuous: for partial restraint	a) Complete joints, ≤ 15 m b) Alternate partial and complete joints (by interpolation), ≤ 11.25 m c) Partial joints, ≤ 7.5 m	Minimum of ρ_{crit}	Use small size bars but less steel than in option 1
3	Close movement joint spacing: for freedom of movement	a) Complete joints, in metres $\leq 4.8 + \frac{w}{\epsilon}$ b) Alternate partial and complete joints, in metres $\leq 0.5s_{max} + 2.4 + \frac{w}{\epsilon}$ c) Partial joints $\leq s_{max} + \frac{w}{\epsilon}$	$2/3 \rho_{crit}$	Restrict the joint spacing for options 3 b) and 3 c)

NOTE 1 References should be made to appendix A for the description of the symbols used in this table and for calculating ρ_{crit} , s_{max} and ϵ .

NOTE 2 In options 1 and 2 the steel ratio will generally exceed ρ_{crit} to restrict the crack widths to acceptable values. In option 3 the steel ratio of $2/3 \rho_{crit}$ will be adequate.

If the joint surface is not roughened until the concrete has hardened, the larger aggregate particles near the surface should be exposed by sandblasting or by applying a scaling hammer or other mechanical device. Powerful hammers should not be used as they may damage or dislodge aggregate particles so reducing, rather than increasing, the capacity of the joint to transfer stresses. Care should be taken that the joint surface is clean immediately before the fresh concrete is placed against it. It may need to be dampened prior to the new concrete being placed, to prevent excessive loss of mix water into it by absorption. Particular care should be taken in the placing of new concrete close to the joint to ensure that it has an adequate fines content and is fully compacted and dense. It is not necessary to incorporate waterstops in properly constructed construction joints.

5.5 Temporary open sections

Where structural continuity is required in the final structure (e.g. the wall of a rectangular tank) the amount of reinforcement required to control early thermal effects may be reduced by the use of temporary open sections.

The width of the open section between adjacent panels should be not greater than 1 000 mm. Properly formed construction joints should be provided at each end of the temporary open section with the longitudinal reinforcement from each adjacent panel lapping in this area.

Provided that the isolated panels satisfy the criteria for option 3 a) of Table 5.1, only the effects of T_2 , the temperature fall due to seasonal variations (see A.3), need be considered when designing the complete continuous structure.

Sufficient time should be allowed for all the early thermal movement to take place before the open section is infilled.

5.6 Joints in ground slabs

The floor of a structure may be designed to permit thermal contraction and shrinkage by minimizing restraints to movement. A separating layer of 1 000 g/m² polyethylene should be provided between the floor slab and the blinding concrete. Panels may be cast in single bays or in larger areas with induced joints.

Alternatively, the floor may be designed as fully restrained against shrinkage and thermal contraction and should be cast directly onto the blinding concrete.

Frequently, in large structures, the floor is designed as a series of continuous strips with transverse induced complete contraction joints provided to ensure that cracking occurs in predetermined positions. Longitudinal joints between the strips should form complete contraction joints.

5.7 Joints in walls

Walls may be designed as fully restrained against thermal contraction and shrinkage, or the restraints may be reduced by providing movement joints in accordance with Table 5.1.

Where the wall is designed to be monolithic with the base slab, a kicker should be cast at the same time as, and integrally with, the slab. The height of the kicker should be at least 75 mm to enable the next lift of formwork to fit tightly and to avoid leakage of cement grout from the newly deposited concrete. The joint in this position will be a construction joint, and although it is recommended that wall panels are cast in one lift, any necessary extra horizontal joints will be construction joints.

In walls to circular structures, one of the predominant forces from the liquid pressure is horizontal hoop tension.

For structural design purposes the horizontal reinforcement should be completely continuous at vertical joints. A central waterstop should be used together with sealing compounds on both faces, whether or not any attempt is made to achieve concrete continuity.

5.8 Joints in roofs

Roof slabs are generally designed as flat slabs, in which case all interior joints should be construction joints so that the slab is structurally monolithic. Early thermal effects and subsequent temperature effects should be considered. Roofs, even those covered by soil, may be subjected to a larger thermal change than the walls and floor, but if the roof is not connected monolithically to the wall the subsequent temperature effects may be disregarded (i.e. reinforcement to control cracking is based only on T_1 , the fall in temperature between the hydration peak and ambient (see A.3)).

Where roofs and walls are monolithic, movement joints in roofs should correspond with those in the walls to avoid the possibility of sympathetic cracking. The final connection between the roof and walls should not be made until the roof is insulated. If, however, provision is made by means of a sliding joint for movement between the roof and walls, correspondence of the joints is less important.

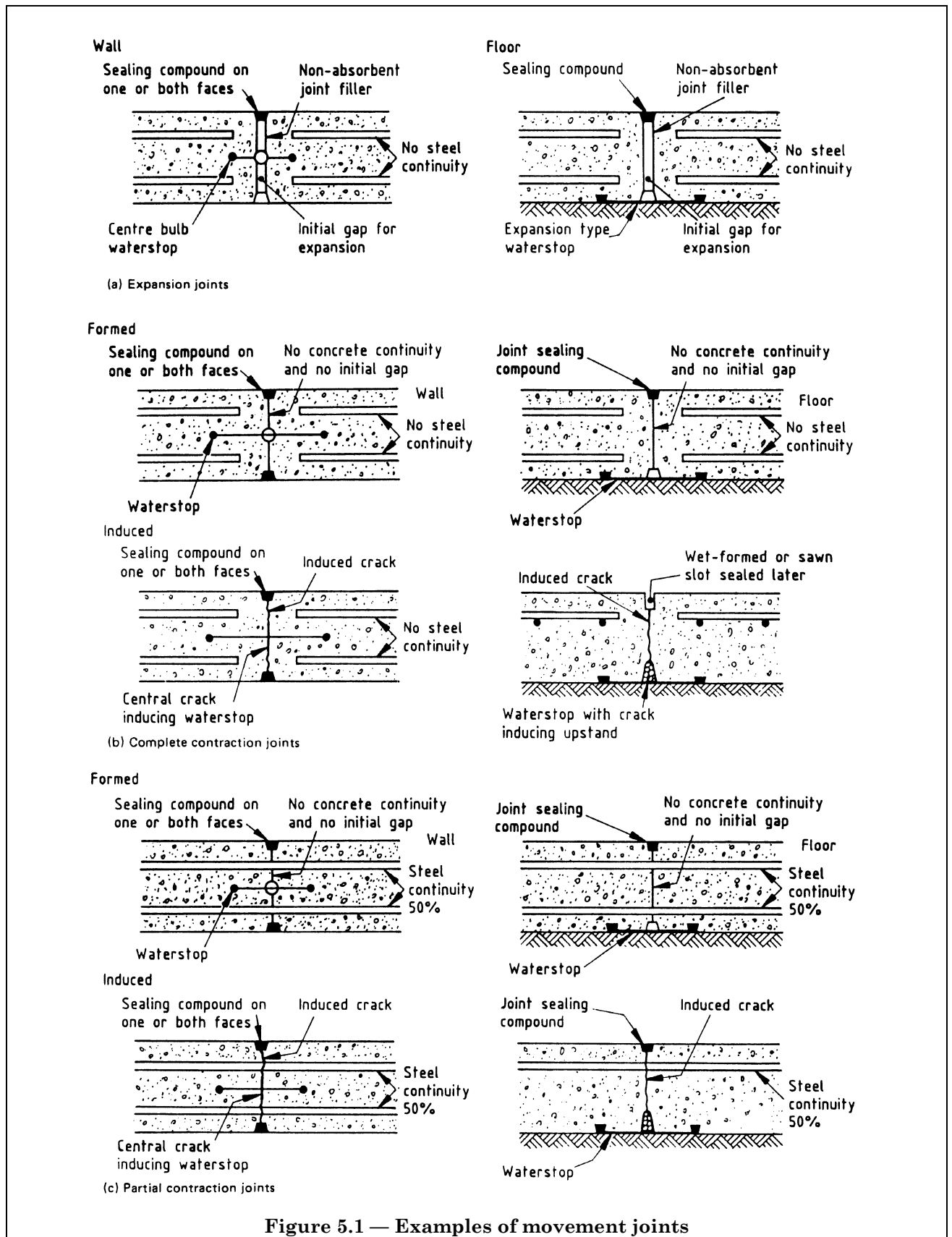

Section 6. Concrete: specification and materials

6.1 General

This section gives methods of specifying, producing and assessing concrete for compliance that will in general ensure that the strength, durability and impermeability will be adequate for liquid-retaining structures. The recommendations in section 6 of BS 8110-1:1985 apply except where these are amended by this code.

6.2 Materials

6.2.1 Cements, ground granulated blastfurnace slags (g.g.b.s) and pulverized-fuel ashes (p.f.a.)

These are to be used as specified in 6.1.2 of BS 8110-1:1985 except that for normal use the target mean proportion of g.g.b.s. should not exceed 50 %. This applies to blended cements (6.1.2.1 b)) and combinations made at the mixer (6.1.2.1 d)). The target mean proportion of p.f.a. should not exceed 35 % as stated in BS 8110-1.

NOTE In this code the term "cement" means Portland cement or a combination of Portland cement and g.g.b.s. in accordance with BS 6699 or p.f.a. in accordance with BS 3892-1, unless otherwise stated.

6.2.2 Aggregates

Aggregates to be used should comply with either BS 882 or BS 1047 and have an absorption, as measured in accordance with BS 812-2:1975, generally not greater than 3 %.

NOTE Coarse aggregates with a low coefficient of thermal expansion are preferred (see BS 8110-2:1985).

6.3 Mix proportions

The minimum cement content should be 325 kg/m^3 . A maximum water/cement ratio of 0.55 should be used except when Portland pulverized-fuel ash cement or a combination of ordinary Portland cement and p.f.a. is used, when the water/cement ratio should be 0.50. The 28-day characteristic cube strength should not be less than 35 N/mm^2 , and the concrete should be classed as grade C35A.

It should be noted that this classification is not in accordance with BS 8110, as higher 28-day strengths may, with some types and proportions of constituent materials, lead to undesirably high cement contents. A reduction in the water/cement ratio may be achieved by the use of plasticizers.

For reinforced concrete the cement content should not exceed either 400 kg/m^3 of ordinary Portland cement or cements containing g.g.b.s. or 450 kg/m^3 where cements containing p.f.a. are used. For prestressed concrete the maximum cement content may be increased to 500 kg/m^3 or 550 kg/m^3 respectively.

6.4 Workability

The workability of the concrete should be specified in relation to the equipment and methods of handling and compaction, so that the concrete is placed without segregation, fully compacted, surrounds all reinforcement, tendons and ducts and completely fills the formwork. It is particularly important to ensure that full compaction is obtained in the vicinity of construction and movement joints, embedded water bars, tendon anchorages, pipes, etc.

6.5 Surface finish of concrete

The type of surface finish to be given to any member will depend on its position in the structure, its exposure, whether or not it is to receive an applied finish and the properties of the liquid to be stored. The recommendations in 6.10 of BS 8110-1:1985 apply.

It is not possible to ensure that a reinforced concrete member will remain uncracked. It is recommended, therefore, that any member that is to be permanently exposed to view is provided with a profile and type of finish that tend to minimize the effects of any surface marking.

6.6 Blinding layer

Where walls or floors are founded on the ground a screeded layer of plain concrete not less than 75 mm thick should be placed over the ground.

In normal circumstances this concrete should have proportions weaker than that used in the remainder of the structure, but not weaker than grade C20 as given in Table 6.2 of BS 8110-1:1985. Where aggressive soil or aggressive groundwater is expected, the concrete should not be weaker than grade C25, and if necessary, a sulphate-resisting or other special cement should be specified.

6.7 Pneumatically applied mortar

The pneumatic application of mortar is a specialist operation and should be carried out only by experienced operators. The designer should agree a full specification with the contractor for materials, mix proportions, mixing, placing, equipment and curing before any work commences.

Section 7. Specification and workmanship: reinforcement

7.1 General

The provisions of section 7 of BS 8110-1:1985 apply.

7.2 Special reinforcement

7.2.1 Galvanized reinforcement

Normal bar and fabric reinforcement may be hot-dip zinc coated in accordance with BS 729. The minimum coating thickness should be 85 μm .

7.2.2 Epoxy coated reinforcement

Reinforcement may be epoxy powder coated with the coating bonded by an electrostatic fusion process. It is essential that the coating process is undertaken in factory conditions, and as there is no British Standard, ASTM A775/A775M-84 should be complied with as a minimum, in respect of the coating.

7.2.3 Stainless steel reinforcement

Bar reinforcement in accordance with the preferred range of sizes given in BS 6744 should be used.

7.2.4 Bond strength

It may be assumed for the design that the bond strength of deformed bar types 1 and 2 is not affected by hot-dip zinc coating or epoxy coating.

NOTE No guidance can be given for coated plain surface bars.

Section 8. Specification and workmanship: prestressing tendons

8.1 General

Prestressing tendons should comply with the recommendations in section 8 of BS 8110-1:1985.

Section 9. Inspection and testing of the structure

9.1 General

Inspection and testing of structures should be carried out in accordance with 2.8. Testing for liquid tightness should be in accordance with 9.2 and 9.3.

9.2 Testing of structures

For a test of liquid retention, the structure should be cleaned and initially filled to the normal maximum level with the specified liquid (usually water) at a uniform rate of not greater than 2 m in 24 h.

When first filled, the liquid level should be maintained by the addition of further liquid for a stabilizing period while absorption and autogenous healing take place. The stabilizing period may be 7 days for a maximum design crack width of 0.1 mm or 21 days for 0.2 mm or greater. After the stabilizing period the level of the liquid surface should be recorded at 24 h intervals for a test period of 7 days. During this 7-day test period the total permissible drop in level, after allowing for evaporation and rainfall, should not exceed 1/500th of the average water depth of the full tank, 10 mm or another specified amount.

Notwithstanding the satisfactory completion of the test, any evidence of seepage of the liquid to the outside faces of the liquid-retaining walls should be assessed against the requirements of the specification. Any necessary remedial treatment of the concrete, cracks, or joints should, where practicable, be carried out from the liquid face. When a remedial lining is applied to inhibit leakage at a crack it should have adequate flexibility and have no reaction with the stored liquid.

Should the structure not satisfy the 7-day test, then after the completion of the remedial work it should be refilled and if necessary left for a further stabilizing period; a further test of 7 days' duration should then be undertaken in accordance with this clause.

9.3 Testing of roofs

The roofs of liquid-retaining structures should be watertight and should, where practicable, be tested on completion by flooding the roof with water to a minimum depth of 25 mm for 24 h or longer if so specified. Where it is impracticable, because of roof falls or otherwise, to contain a 25 mm depth of water, the roof should have water applied by a continuous hose or sprinkler system to provide a sheet flow of water over the entire area of the roof for not less than 6 h. In either case the roof should be considered satisfactory if no leaks or damp patches show on the soffit. Should the structure not satisfy either of these tests, then after the completion of the remedial work it should be retested in accordance with this clause. The roof insulation and covering should be completed as soon as possible after satisfactory testing.

Appendix A Calculation of minimum reinforcement,⁵⁾ crack spacing and crack widths in relation to temperature and moisture effects

A.1 General

The design procedures given in A.2 and A.3 are appropriate to long continuous wall or floor or roof slabs of "thin" cross section. Reference should be made to 5.3.3 for modifications that are necessary when considering the introduction of movement joints. A.4 considers "thick" sections. A.5 considers external restraint factors and their application to thin sections subject to varying degrees of external restraint. Finally, A.6 refers to specialist literature regarding factors other than design that have a significant influence on the degree of thermal and moisture effects.

A.2 Minimum reinforcement⁵⁾

Direct tension cracking from thermal movement is not the same mechanism as that of flexural cracking. After the formation of an initial crack, all the other cracks are influenced by the reinforcement. Provided that the reinforcement across these primary cracks does not yield, the contraction of the concrete at both sides of the crack becomes restrained by the reinforcement. Once this restrained contraction reaches the tensile strain capacity of the concrete, a further crack may be induced. Therefore, the effect of the reinforcement on the cracking pattern is to increase the number of cracks above those given in the primary cracking pattern, but all of the cracks, both primary and secondary, are of a controlled width.

To be effective in distributing cracking the amount of reinforcement provided needs to be at least as great as that given by the equation:

$$\rho_{\text{crit}} = f_{\text{ct}}/f_y$$

where

ρ_{crit} is the critical steel ratio, i.e. the minimum ratio, of steel to the gross area of the concrete section, required to distribute the cracking, "concrete section" being the surface zones given in Figure A.1 and Figure A.2;

f_{ct} is the direct tensile strength of the immature concrete (usually taken at the age of 3 days as 1.6 N/mm² for grade C35A);

f_y is the characteristic strength of the reinforcement as given in Table 3.1 of BS 8110-1:1985.

A.3 Crack spacing

When sufficient reinforcement is provided to distribute cracking the likely maximum spacing of cracks, s_{max} , is given by the equation:

$$s_{\text{max}} = \frac{f_{\text{ct}}}{f_b} \times \frac{\phi}{2\rho}$$

where

$\frac{f_{\text{ct}}}{f_b}$ is the ratio of the tensile strength of the concrete (f_{ct}) to the average bond strength (f_b) between concrete and steel (see Table A.1);

ϕ is the size of each reinforcing bar;

ρ is the steel ratio based on the areas of surface zones (see Figure A.1 and Figure A.2).

For square-mesh fabric reinforcement in which the cross-wires are not smaller than the main wires, it may be assumed that 20 % of the maximum force in the main wires is taken at each welded intersection within the bond development length.

Thus:

$$s_{\text{min}} = \frac{f_{\text{ct}}}{f_b} \times \frac{\phi}{4\rho} (1 - 0.2n_w)$$

where

n_w is the number of welded intersections within the length s_{min} and is normally 1 or 2;

$$s_{\text{max}} = 2s_{\text{min}}$$

For immature concrete [2], the value of f_{ct}/f_b may be taken as unity for plain round bars and two-thirds for deformed (type 2) bars, as shown in Table A.1.

⁵⁾ Although the expression "minimum reinforcement" is used it is possible to have $2/3 \rho_{\text{crit}}$ under option 3 of Table 5.1.

Table A.1 — Factors for the calculation of minimum reinforcement^a for crack distribution and crack spacing (in immature concrete: thermal movement dominant)

Concrete grade	ρ_{crit}		f_{ct}/f_b	
	Grade 250	Grade 460	Plain round bars, $f_b = 1.6 \text{ N/mm}^2$	Deformed bars, type 2, $f_b = 2.4 \text{ N/mm}^2$
C35A	0.0064	0.0035	1.0	0.67
When calculating the area of thermal crack control steel: $A_s = A_c \rho_{crit}$ to distribute the cracking (A.2); or $A_s = A_c \rho$ for specified maximum crack widths (see A.3).				
^a Although the expression "minimum reinforcement" is used it is possible to have $2/3 \rho_{crit}$ under option 3 of Table 5.1.				

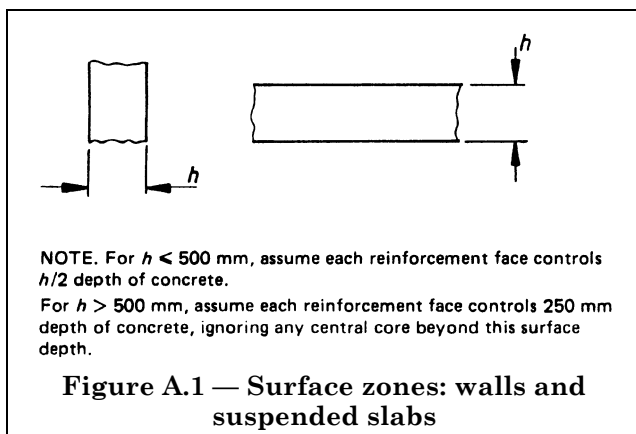

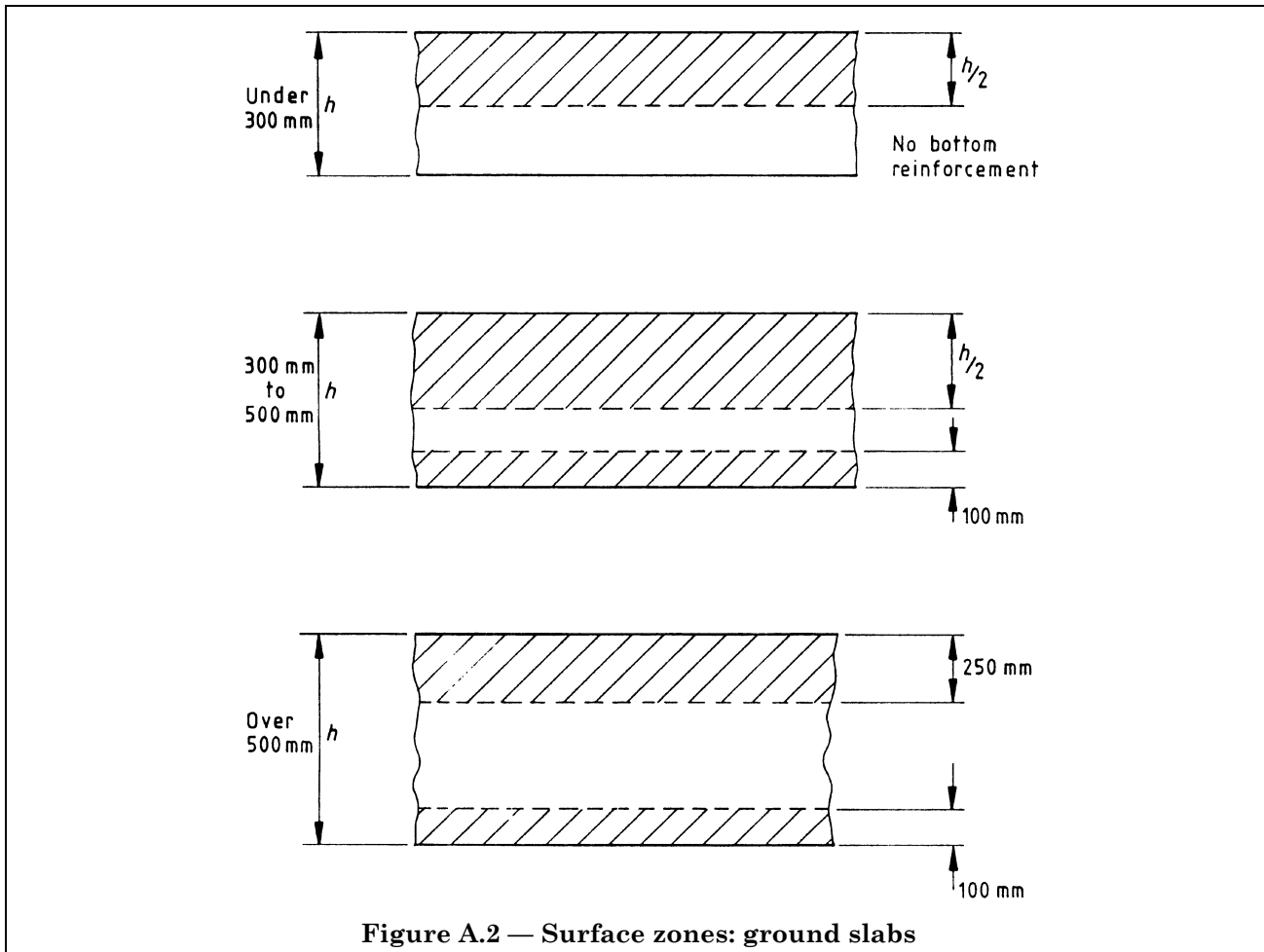

Figure A.2 — Surface zones: ground slabs

The width of a fully developed crack arising from drying shrinkage and thermal movement contraction in restrained walls and slabs may be obtained from:

$$w_{\max} = s_{\max} \epsilon$$

where

w_{\max} is the estimated maximum crack width;

s_{\max} is the estimated likely maximum crack spacing;

ϵ is the effective strain and is obtained from:

$$\epsilon = [\epsilon_{cs} + \epsilon_{te} - (100 \times 10^{-6})]$$

where

ϵ_{cs} is the estimated shrinkage strain;

ϵ_{te} is the estimated total thermal contraction after peak temperature arising from thermal effects.

For immature concrete the coefficient of thermal contraction, less its associated creep strain (which is very high in immature concrete), may be taken as one-half of the value for mature concrete.

For walls and slabs exposed to normal UK climatic conditions, the shrinkage strain less its associated creep strain is generally less than 100×10^{-6} (i.e. about one-half of the ultimate concrete tensile strain) unless high shrinkage aggregates are used (see 2.6.2). Hence the value of w_{\max} for cooling to ambient from the peak hydration temperature may be assumed to be:

$$w_{\max} = s_{\max} \frac{\alpha}{2} T_1$$

where

α is the coefficient of thermal expansion of mature concrete;

T_1 is the fall in temperature between the hydration peak and ambient.

Alternatively, the above may be expressed as:

$$w_{\max} = s_{\max} R a T_1$$

where

R is the restraint factor, being the restrained proportion of the theoretical linear thermal or shrinkage movement, taken as 0.5 for immature concrete with rigid end restraints, after allowing for the internal creep of the concrete.

A low α significantly reduces the percentage of thermal crack control reinforcement required to restrict crack widths (see Table 7.3 of BS 8110-2:1985 for typical values).

Typical values of T_1 for UK concreting using OPC are given in Table A.2. For design purposes T_1 should be assumed to be not less than 20 °C for walls and not less than 15 °C for slabs. In Table A.2 values of T_1 below these are marked with an asterisk.

NOTE For guidance on appropriate values of T_1 when using other types of concrete, see sections 2.4 and 2.5 of CIRIA report no. 91 [3].

Admixtures have little direct effect on the temperature rise, other than to alter the time-scale of the temperature rise.

Provided that durability is not impaired, workability aids and cementitious materials other than OPC may be used to reduce the OPC content and early-age thermal cracking (see section 2.5 of CIRIA report no. 91 [3]).

A concrete placing temperature higher than that assumed in Table A.2 can be expected in the UK on at least a few days each year, but because of the lower total heat evolved with higher placing temperatures, massive sections are unlikely to show more than a 15 % increase over that given in Table A.2. In thin sections, where the rate of heat evolution is controlling the temperature rise, higher placing temperatures, coupled with high daily temperatures, can substantially increase the temperature rise over that given in Table A.2, but these temperature rises cannot be greater than those for massive sections.

The designer should consider whether it is necessary to assume a maximum concrete placing temperature of 25 °C for special UK conditions, such as hot weather and long-haul distances, to ensure that design assumptions are not significantly exceeded.

The minimum and maximum cement content should be specified, and the design should be based on the specified maximum permitted content, unless the actual maximum is known.

In addition to the temperature fall T_1 there can be a further fall in temperature, T_2 , because of seasonal variations. The consequent thermal contractions occur in the mature concrete for which the factors controlling cracking behaviour are substantially modified. The ratio of the tensile strength of the concrete to the average bond strength, f_{ct}/f_b , is appreciably lower for mature concrete. In addition, the restraint along the base of the member tends to be much more uniform and less susceptible to stress raisers, since a considerable shear resistance can be developed along the entire length of the construction joint.

Although precise data are not available for these effects, a reasonable estimate is to assume that the combined effect of these factors, in conjunction with creep, is to reduce the estimated contraction by half. Hence the value of w_{\max} when taking an additional seasonal temperature fall into account is given by:

$$w_{\max} = s_{\max} \frac{\alpha}{2} (T_1 + T_2)$$

or

$$w_{\max} = s_{\max} R \alpha (T_1 + T_2)$$

Thus, in terms of restraint factor, the value of R for mature concrete with rigid external restraint can also be taken as 0.5. If movement joints as indicated in option 2 and 3 of Table 5.1 are provided, then the subsequent temperature fall T_2 need not be considered (see also A.5), provided that the steel has been reduced by 50 % at partial contraction joints.

A.4 Internal restraint in thick sections

For thick sections, major causes of cracking are the differences in temperature that develop between the surface zones and the core of the section (see 3.8.4.1 a) of BS 8110-2:1985). The thickness of concrete that can be considered within the "surface zone" is somewhat arbitrary. However, site observations have indicated that the zone thicknesses for $h > 500$ mm in Figure A.1 and Figure A.2 are appropriate for thick sections, and the procedure for calculating thermal crack control reinforcement in thick sections is then the same as for thin sections.

Table A.2 — Typical values of T_1 for OPC concretes, where more particular information is not available

1	2			3			4		
Section thickness	Walls						Ground slabs: OPC content, kg/m ³		
	Steel formwork: OPC content, kg/m ³			18 mm plywood formwork: OPC content, kg/m ³					
	325	350	400	325	350	400	325	350	400
mm	°C	°C	°C	°C	°C	°C	°C	°C	°C
300	11*	13*	15*	23	25	31	15	17	21
500	20	22	27	32	35	43	25	28	34
700	28	32	39	38	42	49	—	—	—
1 000	38	42	49	42	47	56	—	—	—

NOTE 1 For suspended slabs cast on flat steel formwork, use the data in column 2.

NOTE 2 For suspended slabs cast on plywood formwork, use the data in column 4.

The table assumes the following:

- that the formwork is left in position until the peak temperature has passed;
- that the concrete placing temperature is 20 °C;
- that the mean daily temperature is 15 °C;
- that an allowance has not been made for solar heat gain in slabs.

A.5 External restraint factors

Effective external restraint may be taken as 50 % of the total external restraint because of internal creep. Reference was made in A.3 to movement joints that greatly reduce the rigid external restraint assumed for continuous walls. However, there are other situations where the assumed external restraint factor R can be less than 0.5. Some typical situations for thin sections subjected to external restraint are illustrated in Figure A.3 and allow for any beneficial internal restraints.

Note that no thermal cracking is likely to occur within 2.4 m of a free edge since experience has shown that this is the length of wall or floor slab over which the tensile strain capacity of the concrete exceeds the increasing restrained contraction, the restraint factor varying between zero at the free edge to a maximum of 0.5 at 2.4 m from the free edge. Note that cracking can occur near the ends if stress inducers such as pipes occur within this 2.4 m length of wall or slab. However, if not less than $2/3 \rho_{crit}$, based on the surface zones, is provided and there are no obvious stress raisers, it may be assumed that the free ends of the members will move inwards without cracking up to where $R = 0.5$. Where this is only a temporary free edge and a subsequent bay is cast against the edge, the larger restraint factor for the subsequent bay is shown in parentheses in Figure A.3 and should be assumed [4].

The restraint within a wall or floor panel depends not only on the location within the slab but also on the proportions of the slab. Table A.3 shows how the restraint factors vary between opposite edges, one free and one fixed (e.g. for a wall slab the base section is the fixed edge and the top section is the free edge).

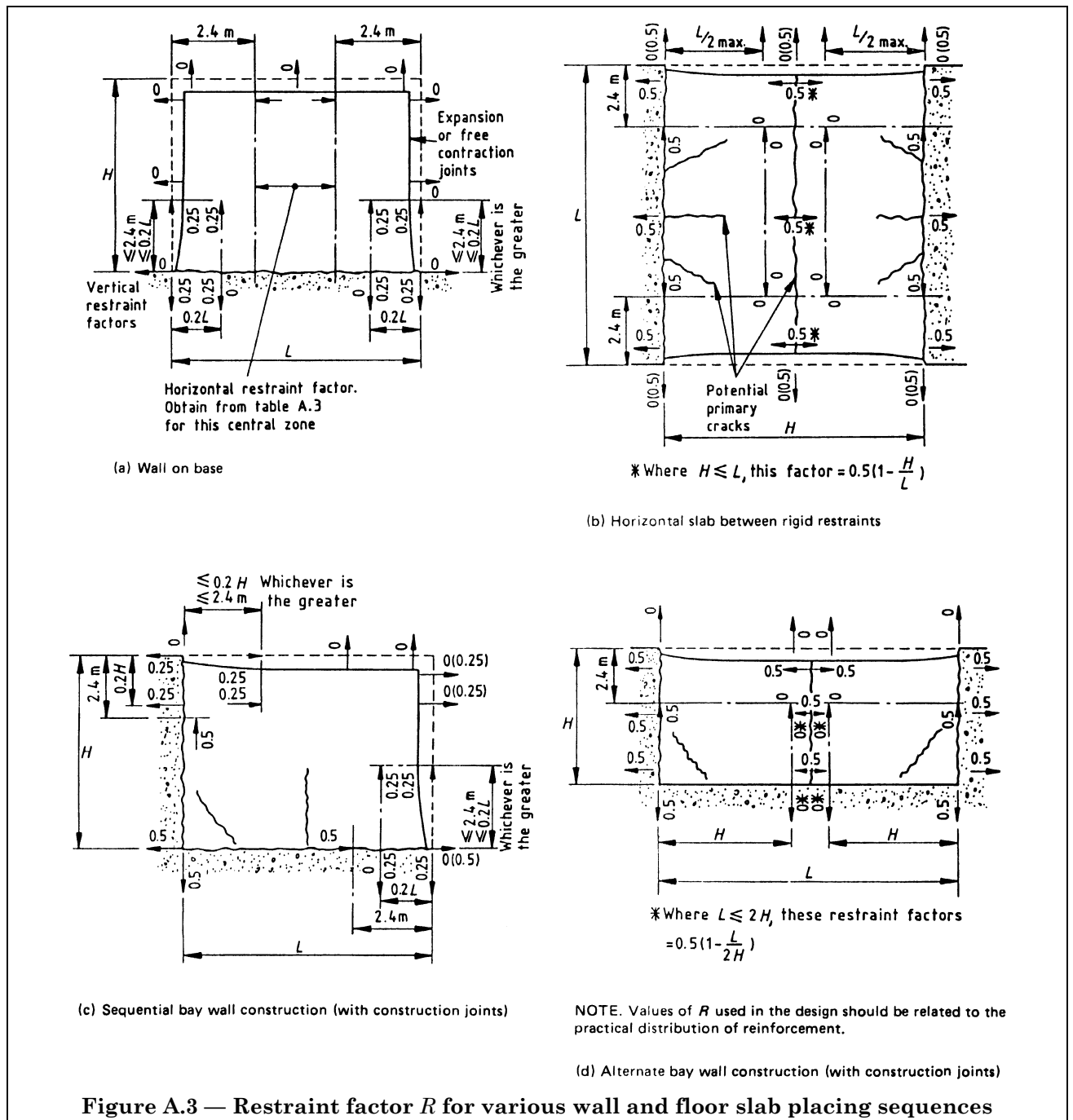

Figure A.3 — Restraint factor R for various wall and floor slab placing sequences

Table A.3 — Influence of slab proportions on the centreline restraint factor

<i>L/H</i> ratio ^a	Design centreline horizontal restraint factors	
	Base of panel	Top of panel
1	0.5 ^b	0
2	0.5 ^b	0
3	0.5 ^b	0.05 ^b
4	0.5 ^b	0.3 ^b
≥ 8	0.5 ^b	0.5 ^b

^a *H* is the height or width to a free edge;
^b *L* is the distance between full contraction joints.
^b These values can be less if *L* < 4.8 m.

The effective external restraint in ground slabs cast on smooth⁶⁾ blinding concrete for the seasonal temperature variation T_2 may be taken as being the design restraint factor $R = 0.5$ at the mid-length, for 30 m lengths and over, and it may be assumed to vary uniformly from 0.5 to zero at the ends.

A.6 Specialist literature

A summary of the factors that help prevent or control early-age thermal cracking, many of which are not within the control of the designer and which should be taken into account in the specification, is given in Table 10 of CIRIA report no. 91 [3].

Appendix B. Calculation of crack widths in mature concrete

B.1 Symbols

For the purposes of this appendix the following symbols apply.

a'	distance from the compression face to the point at which the crack width is being calculated
a_{cr}	distance from the point considered to the surface of the nearest longitudinal bar
A_s	area of tension reinforcement
b_t	width of the section at the centroid of the tension steel
c_{min}	minimum cover to the tension steel
d	effective depth
E_s	modulus of elasticity of the reinforcement
h	overall depth of the member
w	design surface crack width
x	depth of the neutral axis
ϵ_m	average strain at the level where the cracking is being considered
ϵ_1	strain at the level considered ⁷⁾

ϵ_2 strain due to the stiffening effect of concrete between cracks

B.2 Assessment of crack widths in flexure

Provided that the strain in the tension reinforcement is limited to $0.8f_y/E_s$ and the stress in the concrete is limited to $0.45f_{cu}$, the design surface crack width should not exceed the appropriate value given in 2.2.3.3 and may be calculated from equation (1).

$$w = \frac{3a_{cr} \epsilon_m}{1 + 2 \left(\frac{a_{cr} - c_{min}}{h - x} \right)} \quad (1)$$

where ϵ_m is assessed in accordance with B.3.

B.3 Average strain in flexure

The average strain at the level where cracking is being considered is assessed by calculating the apparent strain using characteristic loads and normal elastic theory. Where flexure is predominant but some tension exists at the section, the depth of the neutral axis should be adjusted. The calculated apparent strain ϵ_1 is then adjusted to take into account the stiffening effect of the concrete between cracks ϵ_2 . The value of the stiffening effect may be assessed from B.4, and

$$\epsilon_m = \epsilon_1 - \epsilon_2$$

B.4 Stiffening effect of concrete in flexure

The stiffening effect of the concrete may be assessed by deducting from the apparent strain a value obtained from equation (2) or (3).

For a limiting design surface crack width of 0.2 mm:

$$\epsilon_2 = \frac{b_t(h-x)(a'-x)^2}{3E_s A_s (d-x)} \quad (2)$$

For a limiting design surface crack width of 0.1 mm:

$$\epsilon_2 = \frac{1.5b_t(h-x)(a'-x)}{3E_s A_s (d-x)} \quad (3)$$

The stiffening effect factors should not be interpolated or extrapolated and apply only for the crack widths stated.

B.5 Assessment of crack widths in direct tension

Provided that the strain in the reinforcement is limited to $0.8f_y/E_s$, the design crack width should not exceed the appropriate value given in 2.2.3.3 and may be calculated from equation (4)

$$w = 3\alpha_{cr} \epsilon_m$$

⁶⁾ Power floated and/or use of sheet membrane to break bond.

⁷⁾ Calculated ignoring the stiffening effect of the concrete in the tension zone.

where ϵ_m is assessed in accordance with **B.6**.

B.6 Average strain in direct tension

The average strain is assessed by calculating the apparent strain using characteristic loads and normal elastic theory. The calculated apparent strain is then adjusted to take into account the stiffening effect of the concrete between cracks. The value of the stiffening effect may be assessed from **B.7**.

B.7 Stiffening effect of concrete in direct tension

The stiffening effect of the concrete may be assessed by deducting from the apparent strain a value obtained from equation (5) or (6).

For a limiting design surface crack width of 0.2 mm;

$$\epsilon_2 = \frac{2b_t h}{3E_s A_s} \quad (5)$$

For a limiting design surface crack width of 0.1 mm;

$$\epsilon_2 = \frac{b_t h}{E_s A_s} \quad (6)$$

The stiffening effect factors should not be interpolated or extrapolated and apply only for the crack widths stated.

Appendix C. Jointing materials

C.1 General

The joints described in section 5 require the use of combinations of jointing materials, which may be classified as:

- a) joint fillers;
- b) waterstops;
- c) joint sealing compounds (including primers where required).

These materials are inaccessible once the liquid-retaining structure has been commissioned until the structure is taken out of use. The design uses for these materials in joints should take into account their performance characteristics, both individually and in combination, and the restrictions and difficulties of access to them should the joints not perform as designed. One of the principal problems with joints is obtaining continuously satisfactory adhesion between joint sealing compounds and the concrete surfaces between which they are to provide a liquid-tight seal. Joint sealing compounds cannot be expected to provide a liquid-tight seal for more than a proportion of the life of the structure, and waterstops should always be provided in movement joints.

When proprietary materials or products are used, the recommendations of the manufacturer should be followed.

Jointing materials should be capable of accommodating repeated movement without permanent distortion or extrusion, and they should not be displaced by fluid pressure. The materials should remain effective over the whole range of temperature and humidities considered. For example, they should not slump unduly in hot weather neither should they become brittle when cold. The materials should be insoluble and durable and not change unduly by evaporation of solvent or plasticizers, nor, in exposed portions, should they be altered by exposure to light. Depending on the application, they may need to be non-toxic and taintless and resistant to chemical and biological attack. Ease of handling and of application or installation are important, and the use of jointing materials should not prevent the proper compaction of the concrete next to the joint. Detailing at places where the joint changes direction or intersects another joint should not be unduly complicated. Sealants, unless otherwise specified in this code, should comply with BS 6213.

C.2 Joint fillers

Joint fillers are used in expansion joints as illustrated in section 5. They consist of compressible sheet or strip material fixed to the face of the first-placed concrete and against which the second-placed concrete is cast. They provide the initial separation between the faces of the concrete and compress under the predetermined expansion from each face of the concrete. It is important that the joint filler accommodates the compression without transferring appreciable load across the expansion joint and recovers so that the joint remains filled when the concrete faces subsequently move apart. Since the percentage expansion or contraction of the filler is inversely proportional to the initial width of the joint, there is an advantage in using a wide joint.

The usefulness of a joint filler is increased if the material remains in contact with both faces of the joint throughout joint movements. This is important since the joint filler is used as a support to the joint sealing compound which is usually resisting liquid pressure.

Only non-rotting and non-absorbent materials should be used as joint fillers.

C.3 Waterstops

Waterstops are preformed strips of durable impermeable material that are wholly or partially embedded in the concrete during construction. They are located across joints in the structure to provide a permanent liquid-tight seal during the whole range of joint movements. Waterstops are usually proprietary items with determined performance characteristics in accordance with BS 6213. When specified, waterstops should be appropriate to the required design performance.

The different applications of waterstops are described in section 5 and illustrated in Figure 5.1. It is essential that the concrete placed around the waterstop is well compacted and that the waterstop be fixed and maintained firmly in position until the concrete placing is completed and the concrete has set.

Waterstops may be divided into four categories. The first category, known as the central-bulb type, is used in walls to form expansion, contraction and partial contraction joints. The central bulb is positioned across the joint, and the main waterstop is set parallel to the water-surface of the concrete wall. There is a solid bulb or wing at each end of this type of waterstop, which is made of rubber or flexible plastics such as PVC. The distance of the waterstop from the nearest exposed concrete face should not be less than half the width of the waterstop. The second category is similar to the first category but has no central bulb. It is set in a similar manner to category one, but should be used only in contraction, partial contraction and construction joints. The third category, consisting of surface types of waterstop, is mainly used on the undersides of concrete slabs, and sometimes on the outer face of walls that are backfilled. These waterstops are set into the surface of the concrete each side of contraction or partial contraction joints that are formed. They are also used with a central crack-inducing tongue for induced contraction joints. To secure good compaction of the concrete against the water-stop it should be fixed to a base of blinding concrete or formwork. The use of a surface waterstop is sometimes specified at construction joints. This type of waterstop is usually formed from rubber or flexible plastics such as PVC. The fourth category of waterstop is a rigid type and is specified when, as in construction joints, no movement is expected at the joint but a positive waterstop is required because of the pressure of the contained liquid as in a pressure pipeline. Such waterstops are usually formed from copper or steel strip.

The design of the structure should generally provide for the continuity of the waterstop system across all joints and particularly junctions between floor and wall systems. The correct procedure for making the running joints on site using heat fused butt welds for PVC, vulcanized or pocketed sleeve joints for rubber and brazed or welded lap joints for copper or steel needs to be adopted. Intersections and special junctions such as those that arise between rubber and PVC should be prefabricated.

Metal waterstops can be lapped instead of welded, provided that the gap between them is 5 mm greater than the specified size of the coarse aggregate.

Surface waterstops should be used only in situations where there is sufficient pressure from the outside to ensure that the waterstop remains in position.

C.4 Joint sealing compound

These materials (or sealants) are impermeable ductile materials that are required to provide a liquid-tight seal by adhesion to the concrete throughout the range of joint movements. The sealing performance is obtained by permanent adhesion of the sealing compound to the concrete each side of the joint only, and most sealants should be applied in conditions of complete dryness and cleanliness. There are joint sealing compounds that are produced for application to surfaces that are not dry. The recommendations of the manufacturer should be followed to ensure that the sealing compounds are applied correctly to adequately prepared surfaces. It is necessary that the corners of the concrete each side of the joint are accurately cast as detailed with impermeable concrete to avoid water by-passing the sealant through the concrete. BS 6213:1982 provides guidance on types of constructional sealant and on their selection and correct application, so enabling the specifier to select appropriately from Table 4 of that standard. This table lists the main types of sealants, their suitability for the different types of joints in a variety of liquid-retaining structures. Table 4 and sections 6 and 7 of BS 6213:1982 give guidance on the method of application of the sealants. Table 2 provides an expected service life for the various types, with an indication that 20 years is a reasonable maximum, although in favourable conditions a longer service life may be obtained.

In floor joints, the sealing compound is usually applied in a chase formed in the surface of the concrete along the line of the joint. The actual minimum width will depend on the known characteristics of the material. In floor joints of the expansion type, the sealant is supported by the joint filler. In floor joints, retention of the sealant is assisted by gravity, and in many cases sealing can be delayed until just before the structure is put into service, so that the amount of joint opening subsequently to be accommodated is small. The chase should be neither too narrow nor too deep to hinder complete filling and should be primed before the sealing compound is applied. Here again, a wider joint demands a smaller percentage distortion in the material.

Vertical joints in walls should be primed where necessary and then sealed on the liquid-face with a sealant that is usually pressured by gun or knife into the preformed chase. The sealants should have non-slumping properties and great extensibility.

The long-term performance of a joint sealing compound depends on its formulation, the workmanship with which it is prepared and applied as well as the circumstances of the structure. It would be unwise to depend on the sealing compound for liquid-tightness in the long term and that should be provided by the waterstop. The sealing compound should maintain stability at the face of the joint and preclude the ingress of any hard objects that could impair joint movements.

Appendix D. Bibliography

1. HEALTH AND SAFETY EXECUTIVE. *Articles and substances for use at work*, Guidance note GS 8, August 1977.

HEALTH AND SAFETY EXECUTIVE. *Entry into confined spaces*, Guidance note GS 5, June 1980.

HEALTH AND SAFETY EXECUTIVE. *Occupational exposure limits*, Guidance note EH 40/85, April 1985.

2. HUGHES, B.P. *Control of thermal and shrinkage cracking in restrained reinforced concrete walls*, Technical note 21, CIRIA, London 1976.

3. HARRISON, T.A. *Early-age thermal crack control in concrete*, Report no. 91, CIRIA, London 1981.

4. HUGHES, B.P. *Elimination of shrinkage and cracking in a water-retaining structure*, Technical note 36, CIRIA, London 1971.

Further reading

5. WATER AUTHORITIES ASSOCIATION. *Civil engineering specification for the water industry*, 2nd edition, 1984.

6. ANCHOR, R.D. and HUGHES, B.P. *Guide to BS 8007*, Institution of Structural Engineers, London (to be published).

7. ANCHOR, R.D. *Design of liquid retaining concrete structures*, Surrey University Press, Glasgow 1981.

Publications referred to

BS 729, *Specification for hot dip galvanized coatings on iron and steel articles.*

BS 812, *Testing aggregates.*

BS 812-2, *Methods for determination of physical properties.*

BS 882, *Specification for aggregates from natural sources for concrete.*

BS 1047, *Specification for air-cooled blastfurnace slag aggregate for use in construction.*

BS 3572, *Specification for access fittings for chimneys and other high structures in concrete or brickwork.*

BS 3892, *Pulverized-fuel ash.*

BS 3892-1, *Specification for pulverized-fuel ash for use as a cementitious component in structural concrete.*

BS 4211, *Specification for ladders for permanent access to chimneys, other high structures, silos and bins.*

BS 4449, *Specification for hot rolled steel bars for the reinforcement of concrete.*

BS 4461, *Specification for cold worked steel bars for the reinforcement of concrete.*

BS 4483, *Specification for steel fabric for the reinforcement of concrete.*

BS 5395, *Stairs, ladders and walkways.*

BS 5395-3, *Code of practice for the design of industrial type stairs, permanent ladders and walkways.*

BS 6213, *Guide to selection of constructional sealants.*

BS 6699, *Specification for ground granulated blastfurnace slag for use with Portland cement.*

BS 6744, *Specification for austenitic stainless steel bars for the reinforcement of concrete.*

BS 8110, *Structural use of concrete.*

BS 8110-1, *Code of practice for design and construction.*

BS 8110-2, *Code of practice for special circumstances.*

PD 6501, *The preparation of British Standards for building and civil engineering*

PD 6501-1, *Guide to the types of British Standard, their aims, relationship, content and application.*⁸⁾

ASTM A775/A775M-84 *Specification for epoxy coated reinforcing steel bars, 01.04, American Society for Testing and Materials Philadelphia 1984*

NOTE See also bibliography.

⁸⁾ Referred to in the foreword only.

BSI — British Standards Institution

BSI is the independent national body responsible for preparing British Standards. It presents the UK view on standards in Europe and at the international level. It is incorporated by Royal Charter.

Revisions

British Standards are updated by amendment or revision. Users of British Standards should make sure that they possess the latest amendments or editions.

It is the constant aim of BSI to improve the quality of our products and services. We would be grateful if anyone finding an inaccuracy or ambiguity while using this British Standard would inform the Secretary of the technical committee responsible, the identity of which can be found on the inside front cover. Tel: 020 8996 9000. Fax: 020 8996 7400.

BSI offers members an individual updating service called PLUS which ensures that subscribers automatically receive the latest editions of standards.

Buying standards

Orders for all BSI, international and foreign standards publications should be addressed to Customer Services. Tel: 020 8996 9001. Fax: 020 8996 7001.

In response to orders for international standards, it is BSI policy to supply the BSI implementation of those that have been published as British Standards, unless otherwise requested.

Information on standards

BSI provides a wide range of information on national, European and international standards through its Library and its Technical Help to Exporters Service. Various BSI electronic information services are also available which give details on all its products and services. Contact the Information Centre. Tel: 020 8996 7111. Fax: 020 8996 7048.

Subscribing members of BSI are kept up to date with standards developments and receive substantial discounts on the purchase price of standards. For details of these and other benefits contact Membership Administration. Tel: 020 8996 7002. Fax: 020 8996 7001.

Copyright

Copyright subsists in all BSI publications. BSI also holds the copyright, in the UK, of the publications of the international standardization bodies. Except as permitted under the Copyright, Designs and Patents Act 1988 no extract may be reproduced, stored in a retrieval system or transmitted in any form or by any means – electronic, photocopying, recording or otherwise – without prior written permission from BSI.

This does not preclude the free use, in the course of implementing the standard, of necessary details such as symbols, and size, type or grade designations. If these details are to be used for any other purpose than implementation then the prior written permission of BSI must be obtained.

If permission is granted, the terms may include royalty payments or a licensing agreement. Details and advice can be obtained from the Copyright Manager. Tel: 020 8996 7070.