



BSI Standards Publication

**Electric cables –
Thermosetting insulated,
armoured, fire-resistant
cables of rated
voltage 600/1 000 V for
fixed installations, having
low emission of smoke and
corrosive gases when
affected by fire –
Specification**

Publishing and copyright information

The BSI copyright notice displayed in this document indicates when the document was last issued.

© The British Standards Institution 2015

Published by BSI Standards Limited 2015

ISBN 978 0 580 86731 6

ICS 13.220.99; 29.060.20

The following BSI references relate to the work on this document:

Committee reference GEL/20

Draft for comment 15/30301742 DC

Publication history

First published September 1996

Second edition, October 2000

Third edition, September 2009

Fourth (current) edition, November 2015

Amendments issued since publication

Date	Text affected
-------------	----------------------

Contents

1	Scope	1
2	Normative references	1
3	Terms and definitions	2
4	Voltage designation and fire resistance categories	3
5	Conductors	5
6	Insulation	5
7	Identification of cores	5
8	Laying-up	7
9	Bedding	7
10	Armour	8
11	Oversheath	9
12	Cable marking and additional information	9
13	End sealing	12
14	Schedule of tests	13
15	Test conditions	14
16	Routine tests	14
17	Sample tests	15
18	Type tests	17

Annexes

Annex A (informative)	Guide to use and installation of cables	22
Annex B (normative)	Armour wire tests	28
Annex C (normative)	Compatibility test	30
Annex D (normative)	Abrasion resistance test	31
Annex E (normative)	Insulation resistance constant test on oversheath	31
Annex F (normative)	Resistance of armour	32
Annex G (informative)	Gross cross-sectional area of armour	33
Annex H (normative)	Test for shrinkage of oversheath	34
Annex I (normative)	Fire resistance test for category F2 – Additional provisions for cables with a diameter over 20 mm	35
Annex J (informative)	Guidance on type tests	37

Bibliography	41
--------------	----

List of figures

Figure 1	– An example of the marking on the oversheath of the cable	11
Figure I.1	– Method of mounting a sample for test for resistance to fire with mechanical shock	36

List of tables

Table 1	– Maximum permitted voltages against rated voltage of cable	4
Table 2	– Diameter of armour wire and mass of zinc coating	8
Table 3	– Schedule of tests	13
Table 4	– Two core 600/1 000 V cables with copper conductors	18
Table 5	– Three core 600/1 000 V cables with copper conductors	19
Table 6	– Four core 600/1 000 V cables with copper conductors	20
Table 7	– Five core 600/1 000 V cables with copper conductors	21
Table 8	– Multicore auxiliary 600/1 000 V cables with copper conductors	21
Table A.1	– Selection of cables for a.c. systems	23
Table A.2	– Test voltages after installation	28
Table B.1	– Temperature correction multiplication factors	29
Table C.1	– Compatibility requirements	30
Table D.1	– Vertical load requirements	31
Table F.1	– Maximum resistance of armour for two-, three-, four- and five-core cable	32

Table F.2 – Maximum resistance of armour for 600/1 000 V multicore auxiliary cables 32

Table G.1 – Gross cross-sectional area of armour wires for the two-, three-, four- and five-core 600/1 000 V cable 33

Table G.2 – Gross cross-sectional area of armour wires for 600/1 000 V multicore auxiliary cable 33

Table J.1 – Test schedule for the smoke emission test 38

Summary of pages

This document comprises a front cover, an inside front cover, pages i to iv, pages 1 to 42, an inside back cover and a back cover.

Foreword

Publishing information

This British Standard is published by BSI Standards Limited, under licence from The British Standards Institution, and came into effect on 30 November 2015. It was prepared by Technical Committee GEL/20, *Electric cables*. A list of organizations represented on this committee can be obtained on request to its secretary.

Supersession

This British Standard supersedes BS 7846:2009, which will be withdrawn on 1 December 2016.

Information about this document

This is a full revision of the standard, and introduces the following principal changes.

- a) Interlocked tape armour has been removed as it no longer has market relevance.
- b) 48 core auxiliary cables have been removed as they are no longer market relevant.
- c) The marking requirements have been updated and clarified.
- d) The guide to use given in Annex A has been updated to reflect modern installation practice and the recommendations in BS 8519:2010.
- e) Test methods have been updated in accordance with the latest BS EN standards.

The new edition takes account of:

- BS EN 50363 (replacing certain parts of BS 7655) on materials;
- BS EN 50395 (replacing Annex K of BS 7846:2009) on electrical tests;
- BS EN 50396 (replacing Annex D of BS 7846:2009) on thickness measurement;
- BS EN 60332-1-2 (replacing BS EN 50265-2-1);
- BS EN 60332-3-24 (replacing BS EN 50266-2-4);
- BS EN 62230 (replacing BS EN 50356 and BS 5099) on spark testing.

Product certification/inspection/testing

Users of this British Standard are advised to consider the desirability of third-party certification/inspection/testing of product conformity to this British Standard. Users seeking assistance in identifying appropriate conformity assessment bodies or schemes may ask BSI to forward their enquiries to the relevant association.

Hazard warnings

WARNING. This British Standard calls for the use of substances and/or procedures that can be injurious to health if adequate precautions are not taken. It refers only to technical suitability and does not absolve the user from legal obligations relating to health and safety at any stage.

Use of this document

It has been assumed in the preparation of this British Standard that the execution of its provisions will be entrusted to appropriately qualified and experienced people, for whose use it has been produced.

Presentational conventions

The provisions of this standard are presented in roman (i.e. upright) type. Its requirements are expressed in sentences in which the principal auxiliary verb is "shall".

Commentary, explanation and general informative material is presented in smaller italic type, and does not constitute a normative element.

Contractual and legal considerations

This publication does not purport to include all the necessary provisions of a contract. Users are responsible for its correct application.

Compliance with a British Standard cannot confer immunity from legal obligations.

1 Scope

This British Standard specifies requirements for construction and performance of thermosetting insulated, armoured, fire-resistant cables of rated voltage 600/1 000 V having low emission of smoke and corrosive gases when affected by fire.

This British Standard is applicable to cables for use in fixed installations in industrial areas, buildings or similar applications, where maintenance of power supply during a fire is required for a defined period of time.

This British Standard specifies requirements for the following types of cables:

- a) wire armoured and oversheathed cables with two-, three-, four- or five-cores, and with stranded copper conductor;
- b) multicore auxiliary cables, wire armoured and oversheathed, with stranded copper conductor.

This British Standard specifies four categories of cables based on their performance in tests which assess separately resistance to fire, resistance to fire with water spray and resistance to fire with mechanical shock (Category F2) and which assess resistance to fire with direct mechanical impact and water jet in combination (Categories F30, F60 and F120).

This British Standard is applicable to cables that are designed for a maximum sustained conductor temperature of 90 °C and for a maximum short-circuit conductor temperature of 250 °C (for a maximum of 5 s).

NOTE 1 Limitation on the temperature of the cables might be imposed in situations where they may be touched or where they could touch other materials.

NOTE 2 Annex A gives the guide to use, Annex B gives armour wire tests, Annex C gives compatibility test, Annex D gives abrasion test, Annex E gives insulation resistance constant test on oversheath, Annex F gives resistance of conductor and armour, Annex G gives gross cross-sectional area of armour, Annex H gives a test for shrinkage of oversheath, Annex I gives the fire resistance test for category F2 – additional provisions for cables with a diameter over 20 mm, and Annex J gives notes on type tests.

2 Normative references

The following documents, in whole or in part, are normatively referenced in this document and are indispensable for its application. For dated references, only the edition cited applies. For undated references, the latest edition of the referenced document (including any amendments) applies.

BS 6387, *Test method for resistance to fire of cables required to maintain circuit integrity under fire conditions*

BS 7655-1.2, *Specification for insulating and sheathing materials for cables – Part 1: Cross-linked elastomeric insulating compounds – Section 2: General 90°C application*

BS 7655-1.3, *Specification for insulating and sheathing materials for cables – Part 1: Elastomeric insulating compounds – Section 3: XLPE*

BS 7655-6.1, *Specification for insulating and sheathing materials for cables – Part 6: Thermoplastic sheathing compounds having low emission of corrosive gases, and suitable for use in cables having low emission of smoke when affected by fire – Section 1: General application thermoplastic types*

BS 7671, *Requirements for electrical installations – IET Wiring Regulations – Seventeenth edition*

BS 8491, *Method for assessment of fire integrity of large diameter power cables for use as components for smoke and heat control systems and certain other active fire safety systems*

BS EN 10244-2:2009, *Steel wire and wire products – Non-ferrous metallic coatings on steel wire – Part 2: Zinc or zinc alloy coatings*

BS EN 50363-5, *Insulating, sheathing and covering materials for low voltage energy cables – Part 5: Halogen-free, cross-linked insulating compounds*

BS EN 50395, *Electrical test methods for low voltage energy cables*

BS EN 50396, *Non electrical test methods for low voltage electric cables*

BS EN 60228, *Conductors of insulated cables*

BS EN 60229, *Electric cables – Tests on extruded oversheaths with a special protective function*

BS EN 60332-1-2:2004, *Tests on electric and optical fibre cables under fire conditions – Part 1: Test for vertical flame propagation for a single insulated wire or cable – Procedure for 1 kW pre-mixed flame*

BS EN 60332-3-24:2009, *Tests on electric and optical fibre cables under fire conditions – Part 3: Test for vertical flame spread of vertically-mounted bunched wires or cables – Category C*

BS EN 60754-1, *Test on gases evolved during combustion of materials from cables – Part 1: Determination of the halogen acid gas content*

BS EN 60811-401, *Electric and optical fibre cables – Test methods for non-metallic materials – Part 401: Miscellaneous tests – Thermal ageing methods – Ageing in an air oven*

BS EN 60811-501, *Electric and optical fibre cables – Test methods for non-metallic materials – Part 501: Mechanical tests – Tests for determining the mechanical properties of insulating and sheathing compounds*

BS EN 60811-502, *Electric and optical fibre cables – Test methods for non-metallic materials – Part 502: Mechanical tests – Shrinkage test for insulations*

BS EN 61034-2, *Measurement of smoke density of cables burning under defined conditions – Part 2: Test procedure and requirements*

BS EN 62230, *Electric cables – Spark-test method*

IEC 60050-461, *International Electrotechnical Vocabulary – Part 461: Electric cables*

3 Terms and definitions

For the purposes of this British Standard, the terms and definitions given in IEC 60050-461 and the following apply.

3.1 cable manufacturer

organization that has the capability to both produce and control the conformity of cable made to this British Standard

NOTE See 12.1a) for information on marking the cable with the cable manufacturer's name and identifier.

3.2 length of lay

axial length of one complete turn of the helix formed by one cable component

3.3 routine tests, R

tests made on all production cable lengths to demonstrate their integrity

3.4 sample tests, S

tests made on samples of completed cable, or components taken from a completed cable, adequate to verify that the product meets the design specifications

3.5 type tests, T

tests made before supplying, on a general commercial basis, a type of cable covered by this British Standard, in order to demonstrate satisfactory performance characteristics to meet the intended application

NOTE Type tests are of such a nature that after they have been made, they need not be repeated unless changes are made in the cable materials, design or type of manufacturing process, which might change the performance characteristics.

3.6 values**3.6.1 approximate value**

value which is only indicative

NOTE Values described as "approximate" do not constitute requirements to be checked by measurement.

3.6.2 nominal value

value by which a quantity is designated

NOTE Nominal values usually give rise to values to be checked by measurements taking into account specified tolerances.

3.7 voltages**3.7.1 maximum voltage, U_m**

maximum sustained power-frequency voltage between phase conductors for which the cable is suitable

3.7.2 rated voltage, U_0

nominal power-frequency voltage between conductor(s) and earth for which the cable is suitable

3.7.3 rated voltage, U

nominal power-frequency voltage between phase conductors for which the cable is suitable

3.8 fire resistance

ability of a cable to maintain circuit integrity under fire for a stated period of time and under defined conditions

NOTE The designation 'fire resistant' given to a cable implies that it fulfils the requirements of the relevant fire resistance test.

4 Voltage designation and fire resistance categories

4.1 Voltage designation

The cables shall be designated by the rated voltages U_0 and U , expressed in the form U_0/U .

The rated voltage recognized for the purpose of this standard shall be 600/1 000 V.

NOTE 1 The maximum permitted operating voltages of the system are stated in Table 1.

Table 1 Maximum permitted voltages against rated voltage of cable

Rated voltage of cable U_0/U	Maximum permitted operating voltage of the system			
	a.c.		d.c.	
	Conductor-earth, U_0 max	Conductor-conductor, U_m	Conductor-earth	Conductor-conductor
V	V	V	V	V
600/1 000	700	1 200	900	1 800

In an alternating current system, the rated voltage of the cable shall be at least equal to the nominal voltage of the system for which it is intended.

NOTE 2 Guidance on the selection of cables of appropriate voltage designations for particular systems is given in A.4.

4.2 Fire resistance categories

Cables shall be designated by category according to their fire resistance characteristics as follows:

- Category F2.** Resistance to fire, resistance to fire with water, resistance to fire with mechanical shock, assessed separately, when tested in accordance with 17.6.2;
- Category F30.** Resistance to fire with direct mechanical impact and water jet assessed in combination, when tested in accordance with BS 8491 for 30 min;
- Category F60.** Resistance to fire with direct mechanical impact and water jet assessed in combination, when tested in accordance with BS 8491 for 60 min;
- Category F120.** Resistance to fire with direct mechanical impact and water jet assessed in combination, when tested in accordance with BS 8491 for 120 min.

All cables shall conform to the requirements for category F2.

For cables with 2 cores, 3 cores, 4 cores, 5 cores or 7 cores, with a measured overall diameter of 20 mm or greater, if the manufacturer wishes to claim additional fire resistance the cable shall conform to the requirements for category F30, F60 or F120, as applicable, as specified in 17.6.

If a cable conforms to the requirements for category F60 it shall be deemed to conform to the requirements for category F30 as the tests are identical except for the test durations.

If a cable conforms to the requirements for category F120 it shall be deemed to conform to the requirements for categories F30 and F60 as the tests are identical except for the test durations.

NOTE 1 The test in BS 8491 is only applicable to cables of measured overall diameter of 20 mm or greater.

NOTE 2 Attention is drawn to the fact that the ability of a given cable to meet a particular category in this standard refers only to the test conditions stated, and the level of performance achieved in a particular installation can be influenced by actual installation conditions.

5 Conductors

The conductors shall be annealed copper as given in Table 4 to Table 8, and shall conform to the requirements of BS EN 60228, Class 2.

6 Insulation

6.1 Type of insulation

The insulation shall be type GP 8 conforming to BS 7655-1.3, type GP 6 conforming to BS 7655-1.2, or type EI 5 conforming to BS EN 50363-5, except for the requirement for corrosive and acid gas emissions, which shall only be in accordance with 18.2, and shall apply to all types of insulation. The manufacturer shall declare which insulation type the insulation meets.

6.2 Application

The insulation shall be applied by an extrusion process and cross-linked. The insulation shall be applied either in a single layer, or in a number of layers. Each individual layer shall be compact and homogeneous.

Where more than one layer is used, the complete insulation shall be tested as though it were a single layer.

NOTE 1 The manufacturer should demonstrate that all insulated cores are, as a continuous and on-going part of the manufacturing process, subject to spark testing in accordance with BS EN 62230, using only a.c. or d.c. methods.

NOTE 2 Insulation applied in more than one layer does not conform to the definition of "double insulation" given, for instance, in BS 7671.

The manufacturer shall have the option to apply a tape or tapes under and/or over the insulation. These tapes shall not be considered as part of the insulation for the purposes of testing or measurement.

It shall be possible to remove the insulation without damage to the insulation itself or to the conductor. This shall be checked by visual examination.

6.3 Thickness of insulation

The mean value of the radial thickness of the insulation, when measured in accordance with BS EN 50396, 4.1, shall be not less than the relevant value given in Table 4 to Table 8. The smallest value measured, t_m , shall not fall below 90% of the relevant value given in Table 4 to Table 8 by more than 0.1 mm, i.e.:

$$t_m \geq 0.9t_n - 0.1$$

where:

t_m is the smallest value measured, in millimetres (mm); and

t_n is the radial thickness given in Table 4 to Table 8, in millimetres (mm).

The thickness of any tape(s) over either the conductor or the insulation shall not be included in the measurement of the thickness of the insulation.

7 Identification of cores

7.1 General

The cores of all cables shall be identified either by:

- a) colours; or
- b) numbers

7.2 Coloured cores

Unless otherwise agreed between the manufacturer and the purchaser, the colour coding shall be in accordance with the following standard sequence:

- a) Two-core: brown, blue;
- b) Three-core: brown, black, grey;
- c) Four-core: blue, brown, black, grey;
- d) Five-core: green-and-yellow, blue, brown, black, grey.

It shall be permitted to use other identification colours subject to agreement with the manufacturer, taking into account the core colour requirements specified in BS 7671 or other standards. Where other identification colours are used, the marking requirement as stated in 12.5 does not apply.

NOTE Attention is drawn to BS 7671, Appendix 7 where other core colours that are still required outside the EU are given.

The colour shall be applied:

- a) throughout the insulation;
- b) throughout the outermost layer of insulations that comprise more than one layer; or
- c) via a dedicated colouring layer.

Conformity shall be checked by visual examination.

7.3 Numbered cores

Numbers shall be marked sequentially starting with the number 1.

All cores that are numbered shall be of the same insulation colour.

Numbers on each core shall be printed in a colour contrasting with that of the insulation and shall be legible. Each number shall be repeated at intervals not greater than 70 mm.

Conformity shall be checked by visual examination and measurement.

7.4 Bi-colour combination

On the core marked with the bi-colour combination green-and-yellow, the distribution of the colours shall be such that for every 15 mm length of core, one of these colours shall cover not less than 30% and at most 70% of the surface of the core, while the other colour shall cover the remainder of the surface. Conformity shall be checked by measurement.

NOTE 1 In the case of shaped cores one colour may be applied as one or more stripes, provided that both colours remain readily visible.

NOTE 2 In cases of dispute, and where appropriate to the method of colour marking of the insulation, a suitable test for checking conformity is given in BS EN 50396, 5.2, for circular cores, and in BS 8573:2012, Annex F for shaped cores.

7.5 Clarity and durability

The colour or the number used for core identification shall be clearly identifiable and durable such that it cannot be removed when tested in accordance with BS EN 50396, 5.1.

8 Laying-up

The cores of cables having two, three, four or five cores shall be laid up with a uni-directional lay or right-hand-left-hand alternating direction of lay. Where standard colour coding of cores given in 7.2 has been used, the cores shall be laid up in the sequence given in 7.2.

Auxiliary cables having up to and including seven cores shall be laid-up with a uni-directional lay or with a right-and-left-hand direction of lay.

For multicore auxiliary cables of greater than seven cores, the direction of lay shall alternate for each successive layer.

Numbered cores shall be laid-up in number sequence.

Conformity shall be checked by visual examination.

The maximum length of lay for cores with circular conductors shall not exceed 65 times the diameter of the laid-up cores, and the maximum length of lay for cores with shaped conductors shall not exceed 80 times the diameter of the laid-up cores.

Conformity shall be checked by the test method given in 17.2.

It shall be permitted for the manufacturer to apply synthetic fillers or binder tapes.

It shall be possible to remove the fillers and/or tape(s), if any, from the cable without damaging the insulation of the cores.

Conformity shall be checked by visual examination.

9 Bedding

9.1 General

The bedding shall consist of an extruded layer of polymeric material consistent with the operating temperature of the cable. When tested in accordance with BS EN 60811-501 it shall have a tensile strength of not less than 4 N/mm² and elongation at break of not less than 50%. It shall be possible to remove the bedding without damaging the insulation of the cores. This shall be checked by visual examination.

9.2 Thickness of bedding

When measured in accordance with BS EN 50396, 4.2, the smallest value, t_m , of the radial thickness of the bedding shall not fall below 80% of the relevant nominal value given in Table 4 to Table 8, as applicable, by more than 0.2 mm, i.e.:

$$t_m \geq 0.8t_n - 0.2$$

where:

t_m is the smallest value measured, in millimetres (mm); and

t_n is the nominal thickness given in Table 4 to Table 8, in millimetres (mm).

10 Armour

10.1 General

The armour shall consist of a single layer of galvanized steel wires having nominal dimensions as given in Table 4 to Table 8, as appropriate. The armour shall be applied helically with a left-hand lay for cables having up to and including five cores. For multicore auxiliary cables the armour shall be applied helically with a direction of lay opposite to that of the final layer of cores, except when the cores of the cable have been laid-up with alternating right-and-left-hand lay in which case the armour shall be applied with either a right-hand or a left-hand lay.

The manufacturer shall have the option to apply a tape or tapes under and/or over the armour.

The maximum length of lay for the armour wires of nominal wire diameter up to and including 1.6 mm shall not exceed 20 times the diameter over the armour.

The maximum length of lay for the armour wires of nominal wire diameter 2.0 mm and greater shall not exceed 15 times the diameter over the armour.

Conformity shall be checked by the test method given in 17.3.

10.2 Armour wire

The armour wire shall conform to the following.

- When determined in accordance with B.1, the diameter shall fall within the minimum and maximum wire diameters given in Table 2.
- When determined in accordance with B.2, the mass of zinc coating shall be not less than the relevant value given in Table 2.
- When tested in accordance with B.3, none of the wires shall break.

Table 2 Diameter of armour wire and mass of zinc coating

Nominal wire diameter mm	Wire diameter		Minimum mass of zinc coating g/m ²
	Minimum mm	Maximum mm	
0.90	0.85	0.95	112
1.25	1.18	1.32	150
1.60	1.51	1.69	172
2.00	1.90	2.10	180
2.50	2.37	2.63	195
3.15	2.99	3.31	206

10.3 Joints

Joints in the armour shall be brazed or welded and any surface irregularity shall be removed carefully.

A joint in any armour wire shall be not less than 1 m from the nearest joint in any other armour wire in the complete cable.

10.4 Armour resistance

When measured and corrected to 20 °C in accordance with B.4, the d.c. resistance of the armour of the completed cable shall not exceed the relevant value given in Table F.1 or Table F.2, as applicable.

NOTE For the purposes of calculating maximum fault current, it is also necessary to know the gross cross-sectional area of armour wires. Such information is given in Annex G.

11 Oversheath

11.1 General

The oversheath shall be an extruded layer of Type LTS 1 conforming to BS 7655-6.1.

NOTE Oversheaths are normally black and, when properly formulated and compounded, this provides good resistance to deterioration from outdoor exposure to light. Oversheaths with colours other than black can be provided by agreement between the manufacturer and the purchaser but, unless such oversheaths also include additives to protect the cable from UV, the cables are not suitable for all exposure conditions.

11.2 Application

The oversheath shall be applied in a single layer over the armour. Conformity shall be checked by visual examination.

11.3 Thickness of oversheath

When measured in accordance with BS EN 50396, 4.2, the smallest value, t_m , of the radial thickness of oversheath shall not fall below 80% of the relevant nominal value given in Table 4 to Table 8 by more than 0.2 mm, i.e.:

$$t_m \geq 0.80 t_n - 0.2$$

where:

t_m is the smallest value measured, in millimetres (mm); and

t_n is the nominal thickness given in Table 4 to Table 8, in millimetres (mm).

11.4 Spark testing of oversheath

When tested in accordance with the a.c or d.c test methods and the test voltages specified in BS EN 62230, there shall be no breakdown of the oversheath.

12 Cable marking and additional information

12.1 External marking

The external surface of all cables conforming to this British Standard shall be legibly marked with the following elements.

Element	Example of marking
a) Cable manufacturer	Manufacturer's name and their unique factory identifier

Element	Example of marking
---------	--------------------

NOTE 1 A simplified version of the manufacturer's name, or a trading name of the manufacturer, may be used in place of the full name.

NOTE 2 Any suitable method may be used to unambiguously identify the manufacturer's factory.

NOTE 3 The manufacturer's own trademark or equivalent may be added but this cannot be used instead of the manufacturer's name or identifier.

- | | |
|------------------------|------------------------------|
| b) Electric cable | ELECTRIC CABLE |
| c) Voltage designation | 600/1000 V
600/1000 V AUX |

NOTE 4 See 12.2

- | | |
|---|--|
| d) British Standard number and fire resistance category | BS 7846-F2 ¹⁾
BS 7846-F30 ²⁾
BS 7846-F60 ²⁾
BS 7846-F120 ²⁾ |
|---|--|

NOTE 5 See 12.3

- | | |
|--|--------|
| e) Number of cores and nominal area of conductor | 4 × 70 |
|--|--------|

NOTE 6 See 12.4

- | | |
|------------------------|------|
| f) Year of manufacture | ZZZZ |
|------------------------|------|

NOTE 7 The year of manufacture may take the form of the actual year (e.g. 2015) or a coded year identifier assigned by the manufacturer.

- | | |
|------------------------------------|---|
| g) Standard core colour identifier | H |
|------------------------------------|---|

NOTE 8 See 12.5

The marking of items a) to g) shall be by embossing or indenting on the oversheath.

For cables with overall diameters greater than 15 mm, items a) to d) shall appear, in any sequence that is deemed neither to confuse nor conflict, on two or more primary lines along the axis of the cable, approximately equally spaced around the circumference of the cable. Items e), f), and g) shall appear on either one of the primary lines, or on a secondary line or lines, in any sequence that is deemed neither to confuse nor conflict.

-
- ¹⁾ Marking BS 7846-F2 on or in relation to a product represents a manufacturer's declaration of conformity, i.e. a claim by or on behalf of the manufacturer that the product meets the requirements of the standard. The accuracy of the claim is solely the claimant's responsibility. Such a declaration is not to be confused with third-party certification of conformity.
- ²⁾ Where a manufacturer is claiming conformity to one of the additional optional fire resistance categories F30, F60 or F120, as an alternative to marking BS 7846-F2, the cable may be marked BS 7846-F30, BS 7846-F60 or BS 7846-F120, as applicable. Such a marking on or in relation to a product represents a manufacturer's declaration of conformity, i.e. a claim by or on behalf of the manufacturer that the product meets the requirements of the standard and the requirements for the fire resistance category stated. The accuracy of the claim is solely the claimant's responsibility. Such a declaration is not to be confused with third party certification of conformity.

For cables with overall diameters up to and including 15 mm, items a) to g) shall appear on one or more primary lines along the axis of the cable. Where more than one line is used, they shall be approximately equally spaced around the circumference of the cable.

NOTE 9 The order in which the elements of marking appear along the length of the oversheath is not prescribed, but it is preferred that they be in the order a) to g) as shown in this subclause.

The letters and figures shall consist of upright block characters.

The distance between the beginning of one complete group of specified markings [items a) to g)] and the beginning of the next identical complete group of the markings shall be not more than 550 mm in accordance with Figure 1.

Conformity of the marking shall be checked by visual examination and measurement of at least two complete groups of specified markings.

Figure 1 – An example of the marking on the oversheath of the cable

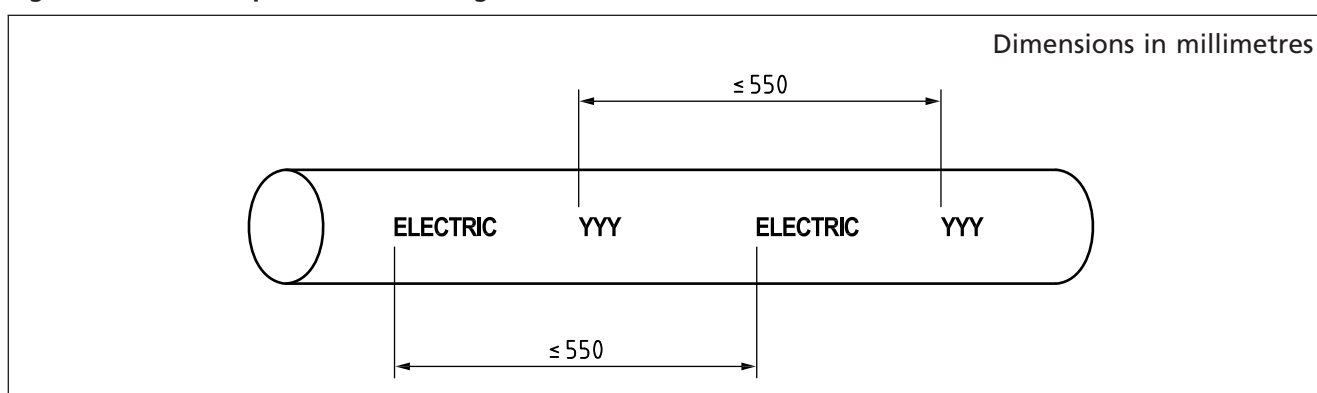

12.2 Voltage designation identifier

Cables manufactured to Table 4, Table 5, Table 6 and Table 7 with coloured cores shall be marked with the voltage designation 600/1 000 V.

Cables manufactured to Table 8 and cables manufactured to Table 4, Table 5, Table 6 and Table 7 with numbered cores shall be marked with the voltage designation 600/1 000 V AUX.

12.3 British Standard number and fire resistance category

Cables shall be marked with the British Standard number and their declared fire resistance category as follows.

- a) If the cable only meets the fire resistance requirement specified in 17.6.2, it shall be marked: "BS 7846-F2".
- b) If the cable meets the fire resistance requirements specified in 17.6.2 and 17.6.3 and is being declared as meeting fire resistance category F30, it shall be marked: "BS 7846-F30".
- c) If the cable meets the fire resistance requirements of 17.6.2 and 17.6.4 and is being declared as meeting fire resistance category F60, it shall be marked: "BS 7846-F60".
- d) If the cable meets the fire resistance requirements of 17.6.2 and 17.6.5 and is being declared as meeting fire resistance category F120, it shall be marked: "BS 7846-F120".

NOTE Clause 4.2 defines those cables for which F30, F60 and F120 are suitable, i.e. up to and including 7 core only and with a measured diameter over 20 mm.

12.4 Number of cores and cross-sectional area identifier

Cables shall be marked with the number of cores they contain and the nominal cross-sectional area of the conductors they contain, i.e.:

$$N \times A$$

where

N is the number of cores;

A is the nominal cross-sectional area of the conductors.

12.5 Standard core colour identifier

When the standard core colour combinations are used in accordance with 7.2, the letter "H" shall be included in the marking on the oversheath of the cable in accordance with 12.1.

12.6 The mark of an approval organization

If the mark of an approval organization is used, it shall be embossed or indented throughout the length of the oversheath of the cable.

The mark shall be in the form of symbol(s) specified by the approval organization, and the maximum distance between marks shall be not greater than 1 100 mm.

12.7 Additional information

Any additional information shall be embossed, indented or printed throughout the length of the oversheath of the cable.

The additional information shall be in one continuous string that does not render illegible the marking specified in 12.1 to 12.6. The distance between the start of one mark and the start of the next identical mark shall be not greater than 1 100 mm. Any additional information shall not conflict or cause confusion with the marking in 12.1, 12.2, 12.3, 12.4, 12.5 and 12.6.

NOTE 1 Marking that is considered to conflict or confuse includes but is not limited by:

- a) *marking of codes of practice, e.g. BS 8519;*
- b) *marking of a fire test standard that is already included in this standard including performance requirements, e.g. BS 8491; or*
- c) *marking of any performance requirements that are included in standards referenced in the document, e.g. Category 3.*

NOTE 2 Marking that is considered not to conflict or confuse includes but is not limited to:

- a) *marking of a fire test standard that is not included in this standard; or*
- b) *marking of the cable's intended application.*

12.8 Durability of additional information

Where the additional information is applied by printing it shall be durable such that it cannot be removed when tested in accordance with BS EN 50396, 5.1.

13 End sealing

Before dispatch, the manufacturer shall cap the ends of the cable in order to form a seal to prevent the ingress of water during transportation and storage.

14 Schedule of tests

The tests to be performed on cables specified in this British Standard shall be as scheduled in Table 3, which refers to the relevant clauses of this standard specifying the requirements and test methods as well as the category of each test which applies, i.e. T, S or R (as defined in Clause 3).

Table 3 Schedule of tests

Test	Requirements given in Clause	Test method	Test category
Conductors	5	BS EN 60228	S
Insulation			
• material	6.1	BS 7655-1.2 or BS 7655-1.3 or BS EN 50363-5	T
• application	6.2	Visual examination	S
• thickness	6.3	BS EN 50396, 4.1	S
Core identification			
• colours and numbers	7.2, 7.3, 7.4	Visual examination and measurement	S
• clarity and durability	7.5	BS EN 50396, 5.1	S
Laying-up			
• direction and sequence of lay	8	Visual examination	S
• length of lay of assembled cores	8	17.2	S
• fillers and binders	8	Visual examination	S
Bedding			
• material	9.1	BS EN 60811-501	T
• application	9.1	Visual examination	S
• thickness	9.2	BS EN 50396, 4.2	S
Armour			
• armour lay length	10.1	17.3	S
• armour wire diameter	10.2a)	B.1	S
• mass of zinc coating	10.2b)	B.2	T
• wrapping test	10.2c)	B.3	T
• armour resistance	10.4	B.4	S
Oversheath			
• material	11.1	BS 7655-6.1	T
• application	11.2	Visual examination	S
• thickness	11.3	BS EN 50396, 4.2	S
• spark test	11.4	BS EN 62230	R
• Cable marking	12	Visual examination and measurement	S
• durability of printed additional information	12.8	BS EN 50396, 5.1	T
Conductor resistance	16.2	BS EN 60228	R
Voltage test on completed cable	16.3	BS EN 50395, 10.3	R
Flame propagation on a single cable	17.4	BS EN 60332-1-2	S
Smoke emission	17.5	BS EN 61034-2	S
Test for resistance to fire – Category F2 ^{A)}	17.6.2	BS 6387, Clauses 6, 7 and 8 and Annex I of this British Standard	S ^{A)}

Table 3 Schedule of tests

Test	Requirements given in Clause	Test method	Test category
Test for resistance to fire – Category F30	17.6.3	BS 8491	S
Test for resistance to fire – Category F60	17.6.4	BS 8491	S
Test for resistance to fire – Category F120	17.6.5	BS 8491	S
Ovality	17.7	17.7	S
Corrosive and acid gas	18.2	BS EN 60754-1	T
Compatibility	18.3	Annex C	T
Shrinkage of insulation	18.4	BS EN 60811-502	T
Abrasion resistance	18.5	Annex D	T
Insulation resistance constant of oversheath	18.6	Annex E	T
Shrinkage of oversheath	18.7	Annex H	T
Flame propagation on multiple cables	18.8	BS EN 60332-3-24	T

NOTE 1 Tests classified as sample (S) or routine (R) might be required as part of a type approval scheme.

NOTE 2 The order of the tests in this schedule does not imply a sequence of testing.

^{A)} If one of the test categories F30, F60 or F120 is being claimed for a cable then category F2 shall be considered as a type approval category T for that cable.

15 Test conditions

15.1 Temperature

Tests shall be performed at a temperature of (20 ± 15) °C unless otherwise specified in the details for the particular test.

15.2 Frequency and waveform of power frequency test voltages

The frequency of the alternating test voltages shall be in the range of 49 Hz to 61 Hz, unless otherwise specified in the particular test. The waveform shall be substantially sinusoidal.

16 Routine tests

COMMENTARY ON CLAUSE 16

In some tests, the preparation and presentation of the test sample can have a critical effect on the result of the tests, so test samples should always be prepared carefully.

16.1 General

Routine tests shall be performed in accordance with Table 3 as indicated by the symbol R in column 4.

NOTE The requirements for routine testing which are not fully covered by earlier clauses are detailed in 16.2 and 16.3.

16.2 Conductor resistance

The d.c. resistance of each conductor shall conform to Clause 5 when measured in accordance with BS EN 60228 and corrected to 20 °C. The measurement shall be made on a drum length of completed cable or on a 1 m sample taken from that drum.

16.3 Voltage test on completed cable

The completed multicore cable shall be tested in accordance with BS EN 50395, 10.3, using a test voltage of 3 500 V a.c. r.m.s. for 5 min between conductors, and between each conductor and the armour which shall be earthed. There shall be no breakdown of the insulation.

The completed multicore auxiliary cables shall be tested as a multicore cable and the cores may be suitably connected for successive application of the test voltage to limit the total testing time. The sequence of connections ensures that the voltage is applied, for the time given, between each conductor and each other conductor, and between each conductor and the armour which shall be earthed. There shall be no breakdown of the insulation.

17 Sample tests

COMMENTARY ON CLAUSE 17

In some tests, the preparation and presentation of the test sample can have a critical effect on the result of the tests, so test samples should always be prepared carefully.

17.1 General

Sample tests shall be performed in accordance with Table 3, as indicated by the symbol S in column 4.

NOTE The requirements for sample testing which are not fully covered by earlier clauses are detailed in 17.2 to 17.7.

17.2 Length of lay of assembled cores

The length of lay of laid-up cores shall be determined by measuring the length of two pitches of a sample and dividing by 2.

If the cores of the cable have been laid up using the right-hand-left-hand alternating direction method, only the right-hand or left-hand portion of the laid-up cores shall be used (i.e. not the transition between directions of lay). The result shall be taken as the length of lay of the laid-up cores.

17.3 Length of lay of armour wires

The length of lay of the laid up armour wires shall be determined by measuring the length of two pitches of a sample and dividing this length by 2. The result shall be taken as the length of lay of the armour wires.

17.4 Flame propagation on a single cable

When tested in accordance with BS EN 60332-1-2, the sample of completed cable shall conform to BS EN 60332-1-2:2004, Annex A.

17.5 Smoke emission

When a sample of the complete cable is tested in accordance with BS EN 61034-2, the minimum value for the light transmittance shall not fall below 70% at any time during the test.

17.6 Tests for resistance to fire

17.6.1 General

All cables shall conform to the requirements for fire resistance category F2 as specified in **17.6.2**.

If, in addition to this, for cables with 2 cores, 3 cores, 4 cores, 5 cores or 7 cores, with a measured 20 mm overall diameter or above, the manufacturer wishes to claim that the cables conform to requirements for fire resistance category F30, F60 or F120, the cables shall be tested in accordance with, and conform to the requirements specified in **17.6.3**, **17.6.4** or **17.6.5**, as applicable.

When fire resistance category F30 is being claimed, then the manufacturer shall test for fire resistance category F2 as specified in **17.6.2** and fire resistance category F30 as specified in **17.6.3**. When fire resistance category F30 is being claimed, then the test for fire resistance category F2 as specified in **17.6.2** shall only be tested as test category T and not as test category S.

When fire resistance category F60 is being claimed, then the manufacturer shall test for fire resistance category F2 as specified in **17.6.2** and fire resistance category F60 as specified in **17.6.4**. When fire resistance category F60 is being claimed, then the test for fire resistance category F2 as specified in **17.6.2** shall only be tested as test category T and not as test category S.

When fire resistance category F120 is being claimed, then the manufacturer shall test for fire resistance category F2 as specified in **17.6.2** and fire resistance category F120 as specified in **17.6.5**. When fire resistance category F120 is being claimed, then the test for fire resistance category F2 as specified in **17.6.2** shall only be tested as test category T and not as test category S.

17.6.2 Category F2

The complete cable shall be tested in accordance with BS 6387, Clause 6 and shall withstand 950 °C for 3 h at a rated voltage of 600/1 000 V without rupture of the 3 A fuse or circuit breaker and with no loss of continuity.

Additionally, complete cables of a diameter not exceeding 20 mm, shall be tested in accordance with BS 6387, Clause 7 and Clause 8 and shall conform to the requirements for protocol W and protocol Z at a rated voltage of 600/1 000 V. For complete cables of a diameter exceeding 20 mm the same requirements shall be met, subject to the additional provisions given in Annex I of this British Standard.

17.6.3 Category F30

A sample of complete cable shall be tested in accordance with BS 8491 for 30 min and shall survive the test without failure for 30 min.

17.6.4 Category F60

A sample of complete cable shall be tested in accordance with BS 8491 for 60 min and shall survive the test without failure for 60 min.

17.6.5 Category F120

A sample of complete cable shall be tested in accordance with BS 8491 for 120 min and shall survive the test without failure for 120 min.

17.7 Ovality

A test sample shall be taken from a cable from three places, separated by at least 1 m. Two diameter measurements shall be taken at the same cross-section of the cable, covering the maximum and minimum values. The difference between each of the two values and their mean shall not exceed 15%.

18 Type tests

COMMENTARY ON CLAUSE 18

In some tests, the preparation and presentation of the test sample can have a critical effect on the result of the tests, so test samples should always be prepared carefully.

18.1 General

Type tests shall be performed in accordance with Table 3, as indicated by the symbol T in column 4.

NOTE The requirements for type testing which are not fully covered by earlier clauses are detailed in 18.2 to 18.8. Guidance on type testing is given in Annex J.

18.2 Corrosive and acid gas

Every non-metallic component shall be tested in accordance with BS EN 60754-1. The level of HCl in each component shall not exceed 0.5%.

18.3 Compatibility

When a sample of complete cable is tested in accordance with Annex C, the insulation and oversheath shall conform to the requirements given in Table C.1. In addition, at the end of the test period in the oven, the blotting paper shall be free of stains.

18.4 Shrinkage of insulation

When a 200 mm sample of core is tested at (130 ± 2) °C for 1 h in accordance with BS EN 60811-502, the shrinkage of the insulation shall not exceed 4%.

The test shall be performed on all cables. For cables having up to five-cores, each core shall be tested. For multicore auxiliary cables, five-cores selected at random shall be tested.

18.5 Abrasion resistance

When a sample of the complete cable is tested in accordance with Annex D, the oversheath shall be deemed to be satisfactory provided that, following the test, examination of the sample with normal or corrected vision without magnification reveals no cracks or splits in the internal and external surfaces.

18.6 Insulation resistance constant of oversheath

When a sample of complete cable is subjected to the test given in Annex E, the value of K shall be not less than $0.0035 \text{ M}\Omega\cdot\text{km}$.

18.7 Shrinkage of oversheath

When a sample of complete cable is tested at (80 ± 2) °C for 4 h in accordance with Annex H, the shrinkage of the oversheath shall not exceed 4%.

18.8 Flame propagation on multiple cables

Cables shall be tested in accordance with BS EN 60332-3-24. The test shall be carried out on a sample of completed cable. After the test, the cable shall conform to the performance recommendations given in BS EN 60332-3-24:2009, Annex B.

Table 4 Two core 600/1 000 V cables with copper conductors

Nominal cross-sectional area of conductor	Radial thickness of insulation	Nominal thickness of extruded bedding	Nominal steel armour wire diameter	Nominal thickness of oversheath	Approximate overall diameter
mm ²	mm	mm	mm	mm	mm
1.5 ^{A)}	0.6	0.8	0.9	1.3	13.0
2.5 ^{A)}	0.7	0.8	0.9	1.4	14.5
4 ^{A)}	0.7	0.8	0.9	1.4	15.5
4 ^{A)C)}	0.7	0.8	1.25	1.4	21.5
6 ^{A)}	0.7	0.8	0.9	1.4	16.5
6 ^{A)C)}	0.7	0.8	1.25	1.4	22.0
10 ^{A)}	0.7	0.8	0.9	1.5	19.0
10 ^{A)C)}	0.7	0.8	1.25	1.5	23.5
16 ^{A)}	0.7	0.8	1.25	1.5	21.5
25 ^{A)}	0.9	0.8	1.25	1.6	21.5
25 ^{B)}	0.9	0.8	1.25	1.6	25.0
35 ^{A)}	0.9	1.0	1.6	1.7	24.5
35 ^{B)}	0.9	1.0	1.6	1.7	28.5
50 ^{B)}	1.0	1.0	1.6	1.8	26.5
70 ^{B)}	1.1	1.0	1.6	1.9	30.0
95 ^{B)}	1.1	1.2	2.0	2.0	34.0
120 ^{B)}	1.2	1.2	2.0	2.1	37.0
150 ^{B)}	1.4	1.2	2.0	2.2	40.0
185 ^{B)}	1.6	1.4	2.5	2.4	46.0
240 ^{B)}	1.7	1.4	2.5	2.5	50.0
300 ^{B)}	1.8	1.6	2.5	2.6	55.0
400 ^{B)}	2.0	1.6	2.5	2.8	60.0

^{A)} Circular or compacted circular stranded conductor (Class 2).

^{B)} Shaped stranded conductor (Class 2).

^{C)} Cables with alternative armour wire size.

Table 5 Three core 600/1 000 V cables with copper conductors

Nominal cross-sectional area of conductor	Radial thickness of insulation	Nominal thickness of extruded bedding	Nominal steel armour wire diameter	Nominal thickness of oversheath	Approximate overall diameter
mm ²	mm	mm	mm	mm	mm
1.5 ^{A)}	0.6	0.8	0.9	1.3	13.5
2.5 ^{A)}	0.7	0.8	0.9	1.4	15.0
4 ^{A)}	0.7	0.8	0.9	1.4	16.5
4 ^{A)C)}	0.7	0.8	1.25	1.4	21.5
6 ^{A)}	0.7	0.8	0.9	1.4	17.5
6 ^{A)C)}	0.7	0.8	1.25	1.4	22.5
10 ^{A)}	0.7	0.8	1.25	1.5	20.5
16 ^{A)}	0.7	0.8	1.25	1.6	22.5
25 ^{A)}	0.9	1.0	1.6	1.7	24.5
25 ^{B)}	0.9	1.0	1.6	1.7	27.5
35 ^{A)}	0.9	1.0	1.6	1.8	26.5
35 ^{B)}	0.9	1.0	1.6	1.8	31.0
50 ^{B)}	1.0	1.0	1.6	1.8	30.0
70 ^{B)}	1.1	1.0	1.6	1.9	33.0
95 ^{B)}	1.1	1.2	2.0	2.1	38.0
120 ^{B)}	1.2	1.2	2.0	2.2	42.0
150 ^{B)}	1.4	1.4	2.5	2.3	47.0
185 ^{B)}	1.6	1.4	2.5	2.4	51.0
240 ^{B)}	1.7	1.4	2.5	2.6	56.0
300 ^{B)}	1.8	1.6	2.5	2.7	61.0
400 ^{B)}	2.0	1.6	2.5	2.9	68.0

A) Circular or compacted circular stranded conductor (Class 2).

B) Shaped stranded conductor (Class 2).

C) Cables with alternative armour wire size.

Table 6 Four core 600/1 000 V cables with copper conductors

Nominal cross-sectional area of conductor	Radial thickness of insulation	Nominal thickness of extruded bedding	Nominal steel armour wire diameter	Nominal thickness of oversheath	Approximate overall diameter
mm ²	mm	mm	mm	mm	mm
1.5 ^{A)}	0.6	0.8	0.9	1.3	14.5
2.5 ^{A)}	0.7	0.8	0.9	1.4	16.0
4 ^{A)}	0.7	0.8	0.9	1.4	17.5
4 ^{A)C)}	0.7	0.8	1.25	1.4	22.5
6 ^{A)}	0.7	0.8	1.25	1.5	20.0
10 ^{A)}	0.7	0.8	1.25	1.5	22.5
16 ^{A)}	0.7	0.8	1.25	1.6	24.5
25 ^{A)}	0.9	1.0	1.6	1.7	27.5
25 ^{B)}	0.9	1.0	1.6	1.7	30.0
35 ^{A)}	0.9	1.0	1.6	1.8	30.0
35 ^{B)}	0.9	1.0	1.6	1.8	33.0
50 ^{B)}	1.0	1.0	1.6	1.9	33.0
70 ^{B)}	1.1	1.2	2.0	2.1	39.0
95 ^{B)}	1.1	1.2	2.0	2.2	43.0
120 ^{B)}	1.2	1.4	2.5	2.3	48.0
150 ^{B)}	1.4	1.4	2.5	2.4	53.0
185 ^{B)}	1.6	1.4	2.5	2.6	58.0
240 ^{B)}	1.7	1.6	2.5	2.7	64.0
300 ^{B)}	1.8	1.6	2.5	2.9	70.0
400 ^{B)}	2.0	1.8	3.15	3.2	79.0

^{A)} Circular or compacted circular stranded conductor (Class 2).

^{B)} Shaped stranded conductor (Class 2).

^{C)} Cables with alternative armour wire size.

Table 7 Five core 600/1 000 V cables with copper conductors

Nominal cross-sectional area of conductor ^{A)}	Radial thickness of insulation	Nominal thickness of extruded bedding	Nominal steel armour wire diameter	Nominal thickness of oversheath	Approximate overall diameter
mm ²	mm	mm	mm	mm	mm
1.5	0.6	0.8	0.9	1.4	15.5
2.5	0.7	0.8	0.9	1.4	17.5
4	0.7	0.8	0.9	1.5	19.0
4 ^{B)}	0.7	0.8	1.25	1.5	20.5
6	0.7	0.8	1.25	1.5	21.5
10	0.7	0.8	1.25	1.6	24.0
16	0.7	1.0	1.6	1.7	27.5
25	0.9	1.0	1.6	1.8	32.5
35	0.9	1.0	1.6	1.9	36.0
50	1.0	1.2	2.0	2.0	42.0
70	1.1	1.2	2.0	2.2	48.0

^{A)} Circular or compacted circular stranded conductor (Class 2).

^{B)} Cables with alternative armour wire size.

Table 8 Multicore auxiliary 600/1 000 V cables with copper conductors

Numbers of cores ^{A)}	Nominal cross-sectional area of conductor ^{B)}	Radial thickness of insulation	Nominal thickness of extruded bedding	Nominal steel armour wire diameter	Nominal thickness of oversheath	Approximate overall diameter
	mm ²	mm	mm	mm	mm	mm
7	1.5	0.6	0.8	0.9	1.4	16.5
7	1.5 ^{C)}	0.6	0.8	1.25	1.4	20.0
12	1.5	0.6	0.8	1.25	1.5	21.5
19	1.5	0.6	0.8	1.25	1.6	24.5
27	1.5	0.6	1.0	1.6	1.7	29.5
37	1.5	0.6	1.0	1.6	1.7	33.0
7	2.5	0.7	0.8	0.9	1.4	18.5
7	2.5 ^{C)}	0.7	0.8	1.25	1.4	20.0
12	2.5	0.7	0.8	1.25	1.6	24.5
19	2.5	0.7	1.0	1.6	1.7	29.0
27	2.5	0.7	1.0	1.6	1.8	34.0
37	2.5	0.7	1.0	1.6	1.8	36.0
7	4	0.7	0.8	1.25	1.5	21.0
12	4	0.7	1.0	1.6	1.6	27.5
19	4	0.7	1.0	1.6	1.7	32.0
27	4	0.7	1.0	1.6	1.9	38.0
37	4	0.7	1.2	2.0	2.0	43.0

^{A)} The numbers of cores given here are preferred. Other numbers up to a maximum of 37 are permitted subject to agreement between the purchaser and the manufacturer and, where such numbers are manufactured, the dimensional details shall be as for the next highest preferred numbers of cores. Auxiliary cables with 2 to 5 cores shall be in accordance with Table 4, Table 5, Table 6 or Table 7, as applicable.

^{B)} Circular or compacted circular stranded conductor (Class 2).

^{C)} Cables with alternative armour wire size.

Annex A
(informative)**Guide to use and installation of cables**

NOTE The details given in this Annex are intended only as general technical guidance and not as interpretation of any UK statutory regulations.

A.1 Aim

The aim of this Annex is to inform users of characteristics and limitations of electric cables and thereby minimize their misuse.

It is assumed that the design of installations and the specification, purchase and installation of cables specified in this British Standard is entrusted to people who meet the definition of a skilled person or instructed person, as given in BS 7671.

NOTE The definitions (taken from BS 7671) are:

- *Skilled person (electrically) – Person who possesses, as appropriate to the nature of the electrical work to be undertaken, adequate education, training or practical skills, and who is able to perceive risks and avoid hazards which electricity can create.*
- *Instructed person (electrically) – Person adequately advised or supervised by a skilled person (as defined) to enable that person to perceive risks and to avoid hazards which electricity can create.*

In cases of doubt as to the suitability of cables for a particular use, further specific guidance should be obtained from the manufacturer.

A.2 General

When selecting cables for their fire performance (circuit integrity), reference should be made to BS 8519 for the selection of cables, installation practice and systems for cable support.

Cables should be installed and used in association with other equipment in accordance with BS 7671.

NOTE 1 Attention is also drawn to any nationally applicable regulations, which in the UK are those referenced in BS 7671 and/or the Electricity Safety, Quality and Continuity Regulations [1], as appropriate.

In special environments, the appropriate regulations and codes of practice should be observed.

The cables specified in this British Standard are intended for installation in air, or for either direct burial in the ground (in free draining soil) or installation within cable ducts that are buried in the ground (in free draining soil). When cables are to be installed in any other environment, guidance should be sought.

Multicore auxiliary cables are frequently used for interconnection of systems, control circuitry and small power circuits. Some codes of practice, dependent on the application and where it is being used may limit the use of such cables and the relevant standards would need to be consulted.

NOTE 2 Attention is drawn to the fact that in countries outside the UK, corresponding national regulations might apply.

A.3 Maximum operating, short circuit and overload temperatures

The cables specified in this British Standard are suitable for use where the combination of ambient temperature and temperature rise due to load results in a conductor temperature not exceeding 90 °C. In the case of short circuit, the maximum allowable time is 5 s and the maximum conductor temperature should not exceed 250 °C. In the case of overload, the maximum allowable time is 4 h and the maximum conductor temperature should not exceed 156 °C. Repeated short circuits and overloads can potentially damage the cable and lead to premature failure.

These operating, short-circuit and overload temperatures are based on the intrinsic properties of the insulating material.

The accessories that are used in the cable system with mechanical and/or soldered connections should be:

- a) suitable for the temperature adopted for the cable;
- b) able to accommodate a cable conductor operating temperature of 90 °C; and
- c) able to accommodate the overload and short circuit temperatures.

A.4 Voltage ratings

The rated voltage of the cable for a given application should be suitable for the operating conditions of the system in which the cable is used. To facilitate the selection of the cable, such systems are divided into the following three categories.

- a) **Category A**, which comprises those systems in which any phase conductor that comes in contact with earth, or an earth conductor, is disconnected from the system within 1 min.
- b) **Category B**, which comprises those systems that under fault conditions are operated for a short time with one phase earthed. This period, according to IEC 60183, should not exceed 1 h. For cables specified in this British Standard, a longer period not exceeding 8 h on any occasion can be tolerated. The total duration of earth faults in any year should not exceed 125 h.
- c) **Category C**, which comprises all systems that do not fall into categories A or B.

NOTE In a system where an earth fault is not automatically and promptly isolated, the extra stresses on the insulation of cables during the earth fault reduce the life of the cables to a certain degree. If the system is expected to be operated fairly often with a permanent earth fault, it might be advisable to classify the system into a higher category.

Table A.1 gives the lowest rated voltage of cable that should be used for an a.c. system according to the system voltage and category.

Table A.1 Selection of cables for a.c. systems

System voltage		System category	Minimum rated voltage of cable
Nominal voltage (U) kV	Maximum sustained voltage (U_m) kV		
Up to 1.0	1.2	A, B or C	0.6/1.0

The nominal system voltage, U , given in Table A.1 is the nominal voltage between phases.

The maximum sustained system voltage, U_m , is the highest voltage between phases that can be sustained under normal operating conditions at any time and at any point in the system. It excludes transient voltage variations, due, for example, to lightning impulses, fault conditions and rapid disconnection of loads.

The cables specified in this British Standard are suitable for d.c. systems operating at up to 900 V conductor to earth and up to 1 800 V between conductors, however the magnetic effect of the armour needs to be taken into account.

Consideration should be given to the peak value when determining the voltage of a d.c. system derived from rectifiers, bearing in mind that smoothing does not modify the peak value when the rectifiers are operating on an open circuit.

A.5 Cable selection and system design

A.5.1 The cables specified in this British Standard are intended for fixed installations and to be used for the supply of electrical energy up to the rated voltage indicated on the cable. **A.4** classifies the voltage ratings of cables manufactured in accordance with this standard. These ratings should not be exceeded.

A.5.2 These cables are intended for use within a nominal power frequency range of 49 Hz to 61 Hz.

A.5.3 For current ratings of cables installed in and around buildings, reference should be made to BS 7671.

A.5.4 Due to the relatively high conductor temperature, there is a risk of drying out the surrounding soil causing an increase in thermal resistivity which in turn would lead to the cable temperature rising to a higher value than anticipated. For cable laid directly in the ground or within cable ducts in the ground, a suitable de-rating factor should be applied or a lower maximum sustained conductor operating temperature should be assumed to take into account the possible effects of soil drying out.

A.5.5 In addition to the current ratings, the following should be taken into account:

- a) the capability of the cable to withstand the worst anticipated fault and overload condition of the system;
- b) the earth loop impedance;
- c) the operating characteristics of the connected equipment; and
- d) the voltage drop requirements during normal load or motor starting conditions.

In installations which include cable joints and terminations, the performance of these accessories should be taken into account in deciding the maximum operating temperature of the cable.

A.5.6 The possible effects of transient over-voltages should be taken into account as they can be detrimental to cables.

A.5.7 The cables are suitable for locations where low levels of emission of smoke and corrosive gases are required in the case of fire.

A.5.8 The cables are intended to provide circuit integrity when appropriately selected and installed.

A.6 Environment and application

COMMENTARY ON A.6

If cables as specified in this British Standard are exposed to localized heat, solar radiation or high temperature ambient conditions or there is a possibility of higher soil thermal resistivity, the current carrying capacity will be reduced.

A.6.1 Cables specified in this British Standard are not specifically designed for use:

- a) as self-supporting aerial cables;
- b) as submarine cable or for laying in water-logged conditions;
- c) where subsidence is likely, unless special precautions are taken to minimize damage;

- d) where any exposure to excessive heat is involved;
- e) where the oversheath is subjected to a voltage test after installation.

A.6.2 Protection against mechanical damage, appropriate to the cable and the installation conditions, should be provided.

A.6.3 Cables could be harmed by exposure to corrosive products or solvent substances, especially petroleum-based chemicals or their vapours. This should be avoided.

A.6.4 Special precautions are required where cables are to be installed in potentially explosive gas atmospheres. Precautions should be taken in accordance with BS EN 60079-14.

A.6.5 The standard oversheathing compounds supplied on the cables specified in this British Standard do not provide protection against damage by rodents, termites etc.

A.6.6 Loaded cables can have high surface temperatures and protection against accidental contact should be provided.

A.7 Installation

A.7.1 General

Cables specified in this British Standard are designed for use in fixed installations in industrial areas, buildings and similar applications. They are also suitable for either direct burial in the ground (free draining soil) or installation within cable ducts that are buried in the ground (free draining soil).

The cables specified in this British Standard are designed for fixed installations only, so they should not be used where they would be subject to flexing.

A.7.2 Minimum temperature during installation

Cables specified in this standard should be installed only when both the cable and ambient temperatures are above 0 °C and have been so for at least the previous 24 h, or where special precautions have been taken to maintain the cable above this temperature.

A.7.3 Minimum installation radius

None of the cables specified in this standard should be bent during installation to a radius smaller than $8D$ where D is the measured overall diameter of the cable.

Wherever possible, larger installation radii should be used.

A.7.4 Preventing damage to cables

Precautions should be taken to avoid mechanical damage to the cables before and during installation.

Careful planning of the route and the method of installation of cable can limit the likelihood of the cable being damaged during installation.

The following points should be taken into account when deciding cable routeing.

NOTE 1 This is not an exhaustive list, as every installation is different.

- a) The minimum installation radius of the cable should not be exceeded (see **A.7.3**).
- b) The number of bends should be reduced to the minimum possible, and installation arrangements made accordingly.

- c) Maximum pulling tensions as advised by the cable manufacturer should not be exceeded.
NOTE 2 Exceeding the manufacturer's recommended maximum pulling tensions could result in damage to the cable.
- d) Maximum sidewall pressure as advised by the cable manufacturers should not be exceeded.
- e) Cable guides should be used where there is a danger of cable oversheath coming into contact with sharp edges.
- f) Rollers, side rollers, skid plates, guides at ducts entry and exit points, and lubricants can aid installation.
- g) A sufficient number of staff should be available to ensure the cable can be installed safely and without damage.
- h) Care should be taken to ensure that the cable is not twisted as it is installed.
- i) The installation speed should not be such that it requires the supply drum to be turned in a dangerous manner.
- j) If the cable is being attached to a pulling rope, it should be done in such a manner as not to cause damage to the cable, or a sufficient length of cable should be sacrificed.

Care should be exercised during installation to avoid any damage to cable coverings. This is particularly important in wet or other aggressive environments such as those that contain oils and petrochemicals. The protective caps should not be removed from the ends of the cable until immediately prior to termination or jointing. When the caps have been removed, the unprotected ends of the cable should not be exposed to moisture.

The possibility of damage to moisture seals during handling and installation or during storage of the cable should be taken into account. Where such damage might have occurred, the seals should be inspected. If moisture ingress has occurred either a sufficient length of cable should be sacrificed or correction actions should be made. The seals should be remade if necessary.

A.7.5 Selection of cable glands, accessories and associated tools

The selection of cable glands, accessories and any associated tools should take account of all aspects of intended use of the cable and its fire resistance. As such, products that are suitable for use should be selected from the following:

- a) Cable glands when used should conform to BS EN 62444.
- b) Cable joints, when used, should conform to BS EN 50393.
- c) Cable cleats, when used, should conform to BS EN 61914.
- d) Cable ties, when used, should conform to BS EN 62275.

The selection of cable support systems, glands and joints should be made in accordance with the recommendations given in BS 8519.

A.7.6 Earth fault currents

Owing to the absence of a metal sheath, all earth fault currents will return through the armour unless there is a parallel bonding connection to relieve them of some of the fault current. In either event it is necessary to ensure that there is no discontinuity in the return circuit via the armour, and the resistance added by bonds and clamps is kept to a minimum.

Careful attention should therefore be paid to the design of all bonding clamps in joints and terminations to ensure that each armour wire contributes equally to the conductance of the bonding connection and that the resistance of the material replacing the armour is not higher than that of the equivalent length of connected armour of the cable.

It is also important to ensure that all armour wires and all faces of armour clamps or connectors making contact with them are thoroughly cleaned during installation and that the clamps are adequately tightened to ensure good electrical contact.

Bonding clamps in joints should be electrically connected with a conducting material having a conductance at least equal to that of the length of armour it replaces, and with adequate thermal capacity to avoid excessive overheating under short circuit conditions.

Provision should be made for earthing the armour to the main earth system at the supply end by means of a metallic bond of adequate conductance, the bonding connection being as short and straight as possible.

Special precautions might be necessary to eliminate the risk of corrosion, especially corrosion due to the use of dissimilar metals.

A.7.7 Joints and terminations

For compound filled joints, the design of the box and the composition of the filling compound should provide an effective seal to prevent moisture gaining access to the conductor ferrules and armour connections.

The filling compound should be compatible with the materials of the cable components with which it comes into contact. Account should be taken of the pouring temperatures or the temperatures resulting from exothermic reaction.

Compound filling is not necessary for terminations, provided that adequate clearances are maintained between phases and between each phase and earth.

The minimum clearances should be related to the voltage and category of the system and the environmental conditions.

Where the required clearances cannot be achieved, some other means of insulation should be provided.

The selection of cable joints and terminations should take account of the performance requirements of the cable and the intended application.

A.8 Storage and handling of drums

NOTE A detailed guide to the safe handling of cable drums is given in BS 8512.

A.8.1 Cable drums should be regularly inspected during storage to assess their physical condition.

A.8.2 Battens, where applied, should not be removed from drums until the cable is about to be installed.

A.8.3 When handling drums, precautions should be taken to avoid injury taking into account the weight, method and direction of rolling, lifting, protruding nails and splinters.

A.8.4 Care should be taken to avoid deterioration of drums or their becoming a hazard to the general public.

A.9 Waste and scrap cable

Information and guidance on the incineration of scrap cable should be obtained from the Environment Agency or equivalent national or regional bodies.

A.10 Voltage test after installation

A voltage test after installation is not a requirement of this standard. If, however, a test is made it should be performed with direct current, the value of the voltage being as given in Table A.2.

Table A.2 Test voltages after installation

Cable voltage designation	D.C. test voltage	
	Between conductors	Between each conductor and armour
V	V	V
600/1 000	3 500	3 500

During the test, the voltage should be increased gradually to the full value and maintained continuously for 15 min. The test should be made between conductors and between each conductor and the armour.

No breakdown should occur.

Sequential testing may be used to reduce overall testing time for multicore auxiliary cables.

The test voltages given in Table A.2 are intended for cables immediately after installation and not for cables that have been in service. When testing is required after cables have been in service, regardless of service duration, the manufacturer should be consulted for the appropriate test conditions, which depend on the individual circumstances.

Care should be taken when voltage testing cables during and immediately after installation, as repeated testing can lead to premature failure of the cable.

Annex B (normative)

Armour wire tests

B.1 Measurement of diameter of round wire armour

Take at random, from one sample of completed cable, 10% of the total number of wires, and determine the diameter of each wire with a micrometer by taking two measurements at right angles to each other. Take the mean of all the measurements as the wire diameter.

B.2 Mass of zinc coating of galvanized steel wire

Take at random, from one sample of completed cable, 10% of the total number of wires and determine the mass of zinc coating by either a gravimetric or gas volumetric method as described in BS EN 10244-2:2009, 5.2. Take the average of all the measurements as being the mass of zinc coating.

B.3 Wrapping test for galvanized steel wire

Take at random, from one sample of completed cable, 10% of the total number of wires. Wrap each wire round a cylindrical mandrel for one complete turn. The mandrel shall have a diameter of approximately four times the specified nominal diameter (see Table 2) of the wire under test.

B.4 Armour resistance test

Determine the d.c. resistance of the armour by measuring the resistance of all the armour wires of the completed cable connected together.

Use the temperature correction multiplication factor, k_t given in Table B.1, to correct the measured resistance at t °C to 20 °C.

Table B.1 Temperature correction multiplication factors

Temperature of armour at time of measurement, t °C	Correction factor k_t
5	1.07 2
6	1.06 7
7	1.06 2
8	1.05 7
9	1.05 2
10	1.04 7
11	1.04 2
12	1.03 7
13	1.03 3
14	1.02 8
15	1.02 3
16	1.01 8
17	1.01 4
18	1.00 9
19	1.00 5
20	1.00 0
21	0.99 6
22	0.99 1
23	0.98 7
24	0.98 2
25	0.97 8
26	0.97 4
27	0.96 9
28	0.96 5
29	0.96 1
30	0.95 7
31	0.95 3
32	0.94 9
33	0.94 5
34	0.94 1
35	0.93 7

NOTE The values of correction factor k_t are based on resistance temperature coefficients at 20 °C of 0.004 5 per K for galvanized steel wire.

Annex C (normative)

Compatibility test

C.1 General

This test determines whether the insulation and oversheath are likely to deteriorate due to contact with the other components in the cable.

C.2 Procedure

C.2.1 Prepare a test sample by ageing it in an air oven in accordance with BS EN 60811-401, for 7 days at (100 ± 2) °C.

C.2.2 Place a sheet of clean white blotting paper under each test sample in the oven to detect any exudate which might drip from the cable.

C.2.3 After completion of the ageing test, the tensile strength and the elongation at break for insulation and oversheath shall conform to Table C.1 when measured in accordance with BS EN 60811-501.

Table C.1 Compatibility requirements

Component	Parameter	Requirement			
		GP 8	GP 6	EI 5	LTS 1
Insulation	Minimum tensile strength (N/mm ²)	12.5	8.5	10	—
	Minimum percentage elongation at break	200	200	125	—
	Maximum percentage variation ^{A)} of tensile strength	±25	±30	±30	—
	Maximum percentage variation ^{A)} of elongation at break	±25	±30	±30	—
Oversheath	Minimum tensile strength (N/mm ²)	—	—	—	10
	Minimum percentage elongation at break	—	—	—	100
	Maximum percentage variation ^{A)} of tensile strength	—	—	—	±40
	Maximum percentage variation ^{A)} of elongation at break	—	—	—	±40

^{A)} The variation is the difference between the respective values obtained prior to and after heat treatment, expressed as a percentage of the former.

Annex D (normative)

D.1 Abrasion resistance test General

This test determines the abrasion resistance of the complete cable.

D.2 Test method

A sample of the complete cable shall be tested in accordance with BS EN 60229, 4.1.2.1, using the vertical load specified in Table D.1.

Table D.1 Vertical load requirements

Overall measured diameter of cable		Force
Greater than or equal to	Less than	
mm	mm	N
—	10	10
10	20	15
20	30	35
30	40	65
40	50	105
50	60	155
60	70	210
70	80	270
80	90	340

Annex E (normative)

E.1 Insulation resistance constant test on oversheath Procedure

Immerse a length of at least 5 m of completed cable for at least 12 h in water at (20 ± 5) °C, leaving a length of about 250 mm at each end projecting above the water. Maintain the temperature of the water at (20 ± 1) °C for the 30 min immediately preceding the test. Apply a voltage of between 80 V and 500 V d.c. between the armour and the water. Measure the insulation resistance 1 min after the application of the voltage.

E.2 Calculation of results

Calculate the insulation resistance constant (*K* value) in $M\Omega \cdot km$ from the equation:

$$K = \frac{IR}{1000 \log_{10}(D/d)}$$

where:

- D* is the diameter over the oversheath in millimetres (mm)
- d* is the diameter over armour in millimetres (mm)
- l* is the immersed length of cable in metres (m)
- R* is the insulation resistance of the length of the cable in megohms ($M\Omega$)

Annex F
(normative)**Resistance of armour**

The maximum values of the conductor resistance and of the resistance of galvanized steel wire armour for multicore cables with rated voltage of 600/1 000 V, as designated in Table 4 to Table 8 shall be as specified in Table F.1 or Table F.2 as applicable.

Table F.1 **Maximum resistance of armour for two-, three-, four- and five-core cable**

Nominal cross-sectional area of conductor mm ²	Maximum resistance per km of cable 20 °C			
	Steel wire armour			
	Two-core	Three-core	Four-core	Five-core
	Ω	Ω	Ω	Ω
1.5	10.2	9.5	8.8	8.2
2.5	8.8	8.2	7.7	6.8
4	7.9	7.5	6.8	6.2
6	7.0	6.7	4.3	3.9
10	6.0	4.0	3.7	3.4
16	3.7	3.5	3.1	2.2
25	3.7	2.5	2.3	1.8
35	2.6	2.3	2.0	1.6
50	2.3	2.0	1.8	1.1
70	2.0	1.8	1.2	0.94
95	1.4	1.3	1.1	—
120	1.3	1.2	0.76	—
150	1.2	0.78	0.68	—
185	0.82	0.71	0.61	—
240	0.73	0.63	0.54	—
300	0.67	0.58	0.49	—
400	0.59	0.52	0.35	—

Table F.2 **Maximum resistance of armour for 600/1 000 V multicore auxiliary cables**

Nominal cross-sectional area of conductor mm ²	Maximum resistance per km of cable 20 °C				
	Steel wire armour ^{A)}				
	7 cores	12 cores	19 cores	27 cores	37 cores
	Ω	Ω	Ω	Ω	Ω
1.5	7.5	4.0	3.5	2.3	2.0
2.5	6.3	3.5	2.3	1.9	1.7
4.0	4.0	2.3	2.0	1.7	1.2

^{A)} For a non-preferred number of cores, the maximum resistance shall not be greater than that of the next lowest preferred number of cores. For 6 core cables this shall be as for 5 core cables.

Annex G
(informative)**Gross cross-sectional area of armour**

Table G.1 and Table G.2 give gross cross-sectional areas of armour for use in calculating the maximum fault current permissible for conformity to the earthing arrangements and protective conductor requirements of BS 7671.

Table G.1 **Gross cross-sectional area of armour wires for the two-, three-, four- and five-core 600/1 000 V cable**

Nominal cross-sectional area of conductor mm ²	Gross cross-sectional area of armour wires			
	Two-core mm ²	Three-core mm ²	Four-core mm ²	Five-core mm ²
1.5	15	16	17	19
2.5	17	19	20	22
4	19	20	22	25
6	22	23	36	40
10	26	39	42	46
16	42	45	50	72
25	42	62	70	88
35	60	68	78	100
50	68	78	90	144
70	80	90	131	166
95	113	128	147	—
120	125	141	206	—
150	138	201	230	—
185	191	220	255	—
240	215	250	289	—
300	235	269	319	—
400	265	304	452	—

NOTE The values stated in Table G1 are indicative only and for specific values required to calculate pulling tensions the manufacturer should be consulted.

Table G.2 **Gross cross-sectional area of armour wires for 600/1 000 V multicore auxiliary cable**

Nominal cross-sectional area mm ²	Gross cross-sectional area of armour wires				
	Number of cores				
	7 mm ²	12 mm ²	19 mm ²	27 mm ²	37 mm ²
1.5	20	39	45	70	78
2.5	24	45	70	84	94
4	39	68	80	96	138

NOTE 1 For a non-preferred number of cores, the gross cross-sectional area of armour will be at least equal to that of the next lowest preferred number of cores. For 6 core cables this shall be as for 5 core cables.

NOTE 2 The values stated in Table G2 are indicative only and for specific values required to calculate pulling tensions the manufacturer should be consulted.

**Annex H
(normative)****Test for shrinkage of oversheath****H.1****General**

This test determines the shrinkage of the oversheath during heat treatment.

H.2 Selection of samples

Take one sample of each cable to be tested, about 300 mm in length, and at least 500 mm away from the end of the cable length.

H.3 Preparation of test piece

Within an interval of not more than 5 min from the time of cutting the sample, mark a test length of (200 ± 5) mm on the middle part of the test piece. Measure the distance between the marks to an accuracy of 0.5 mm.

Prepare the test piece by removing the oversheath from both ends of the sample up to positions between 2 mm and 5 mm away from the marks. Bind the armour wires at each end of the test piece.

H.4 Procedure

Perform the test in an electrically heated air oven capable of maintaining a temperature of (80 ± 2) °C. Support the test piece by means of a freshly prepared talc bath. The combined volume of talc bath and test piece shall not exceed 10% of the volume of the oven. Preheat the oven, with the talc bath in place, for a minimum of 2 h at 80 °C before the test piece is introduced.

Support the test piece horizontally on the surface of the talc bath. Ensure that there is sufficient depth of talc so that the test piece does not touch the bottom of the bath. Spread the talc evenly, without compacting it, at the start of the test, so as to permit free movement of the oversheath.

Introduce the test piece into the oven, and maintain it at a temperature of (80 ± 2) °C for 4 h. At the end of this period, remove the apparatus with the test piece in place, and allow it to cool to room temperature.

Re-measure the distance between the two marks on the test piece to an accuracy of 0.5 mm.

H.5 Evaluation of results

Calculate the difference in the distance between the marks before the heat treatment and after the heating and cooling, and record the shrinkage as a percentage of the distance between the marks before treatment.

Annex I
(normative) **Fire resistance test for category F2 – Additional provisions for cables with a diameter over 20 mm**

I.1 Test for resistance to fire with water

Cables of a diameter greater than 20 mm shall be tested in accordance with BS 6387, Clause 7 adjusting the positions of the cable and burner in accordance with BS 6387, 7.1.5 without reference to the particular dimensions given in BS 6387, Figure 4.

I.2 Test for resistance to fire with mechanical shock

Cables greater than 20 mm in diameter shall be tested in accordance with BS 6387, Clause 8 with the following modifications.

- a) The cable shall be bent to form a “U” shape. The internal radius of the bend shall be as given in A.7.3.
- b) The cable shall be mounted as shown in Figure I.1.
- c) The position of the thermocouple shall be aligned with the lower surface of the cable as shown in Figure I.1.
- d) The clips shall support the cable as shown in Figure I.1.

Figure I.1 Method of mounting a sample for test for resistance to fire with mechanical shock

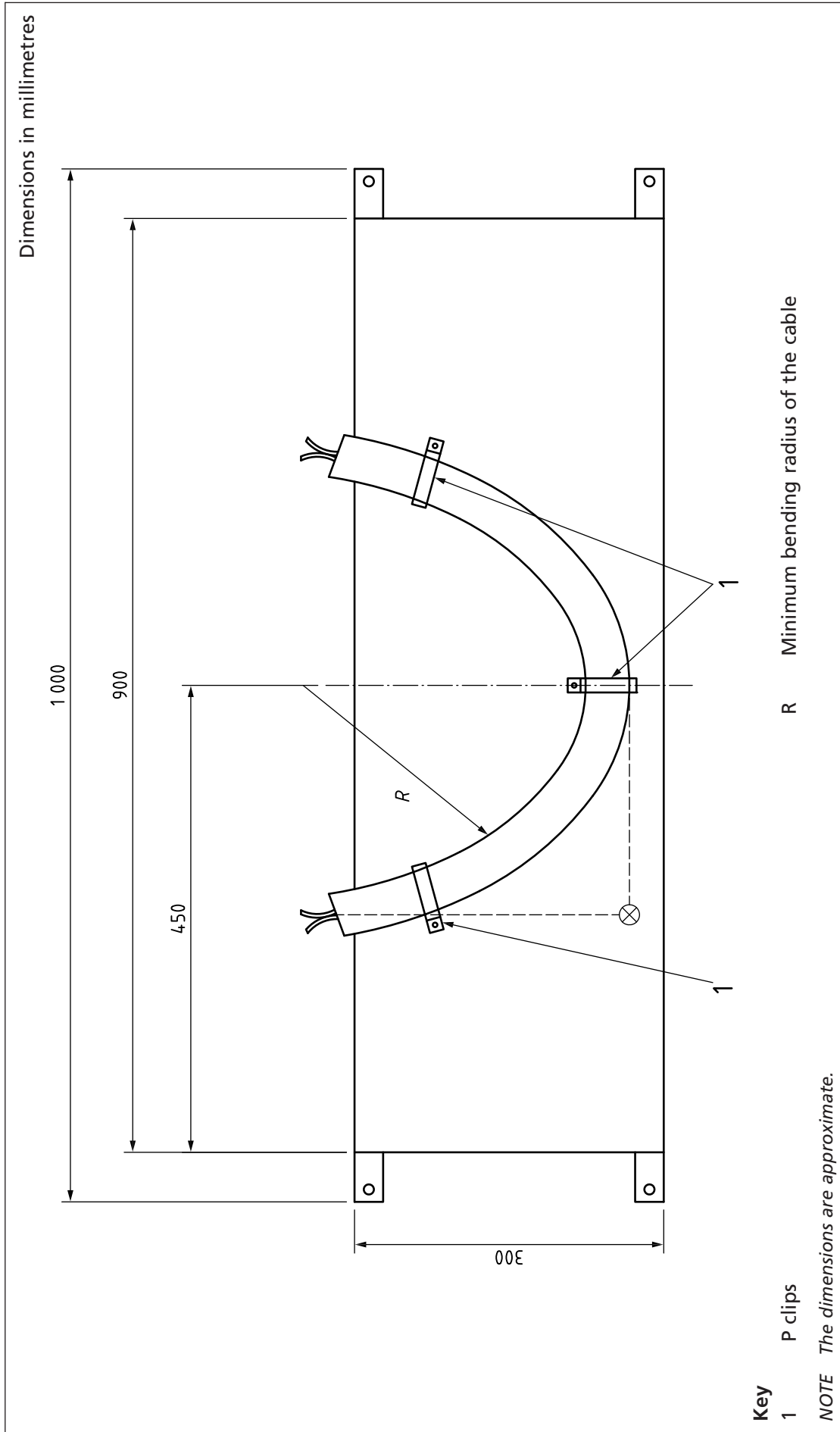

Annex J (informative)

J.1 **General**

Type tests, after they have been completed, need not be repeated unless changes have been made that affect conformity to the performance requirements. This means that type tests are not normally required on cables for any individual contracts provided that such type tests have already been successfully performed by the manufacturer.

Sub-clauses J.2, J.3 and J.4 give guidance as to the amount of type testing that might be required.

J.2 **Sample selection for type tests**

J.2.1 **General**

Type tests for components may be performed on any one cable sample.

NOTE The results of these type tests are not determined by the cable size or construction.

For the type tests on finished cable, conformity to the requirements should be confirmed for the complete range of cables in this standard by selecting samples for testing as follows.

- For multicore cable specified in Table 4 to Table 7 the smallest conductor size with smallest number of cores, and the largest conductor size with the largest number of cores for that size, and an appropriate mid-range sized cable should be tested.
- For multicore auxiliary cable specified in Table 8, any one cable taken from the range stated should be tested.

Where multiple ranges from the above selection are being covered, consideration may be given to reduce the number of samples taken.

To comply with smoke testing requirements (17.5 and J.2.8) and the resistance to fire tests (17.6 and J.2.9) and the flame propagation on multiple cable test requirements (18.8 and J.2.16), specific cable sizes may need to be selected. In addition, where manufacturers wish to demonstrate conformity of cables to this standard, the cable samples should be subjected to full dimensional checks and to all other sample (S) and routine (R) tests given in Table 3.

J.2.2 **Insulation material test (see 6.1)**

One test should be performed for each grade of insulation material on any one cable from the range of cables selected.

J.2.3 **Bedding material test (see 9.1)**

One test should be performed for each grade of bedding material on any one cable from the range of cables selected.

J.2.4 **Armour wire test (see 10.2)**

One test should be performed on each size and material grade of armour wire from the range of cables selected.

J.2.5 **Oversheath material test (see 11.1)**

One test should be performed for each grade of oversheath material on any one cable from the range of cables selected.

J.2.6 Durability of printing test (see 12.8)

One test should be performed on any one cable from the range of cables selected.

J.2.7 Corrosive and acid gas test (see 18.2)

As this is a test on a cable component and is therefore generally independent of size or number of cores, only one test should be carried out on each component.

J.2.8 Smoke emission test (see 17.5)

NOTE This test is classified as a sample test. The guidance given in J.2.8 applies to type testing.

The loss of light transmittance during the 3 m cube test is a function of cable size. Therefore, although a range of cables might have identical components, tests on two different sizes of cable are necessary, in accordance with Table J.1, to confirm conformity for either the complete or a limited range.

Table J.1 Test schedule for the smoke emission test

Size range for which conformity is to be established	Number of lengths for each test (see 17.5)
Complete ^{A)}	3 and 1
Cables sizes up to 40 mm ^{B)}	3 and 2
Cable sizes above 20 mm ^{C)}	2 and 1
Cables sizes up to 20 mm ^{D)}	3

^{A)} For "complete" approval, two samples should be selected to give respectively 3 lengths and 1 length.

^{B)} For "cable sizes up to 40 mm" approval, two samples should be selected to give respectively 3 lengths and 2 lengths.

^{C)} For "cable sizes above 20 mm" approval, two samples should be selected to give respectively 2 lengths and 1 length.

^{D)} For "cable sizes up to 20 mm" approval, one sample should be selected to give 3 lengths.

J.2.9 Fire resistance tests (see 17.6)**J.2.9.1 General**

NOTE 1 It is at the discretion of the manufacturer whether to claim approval against any of the cables that are suitable for the additional fire resistance categories F30, F60 or F120 (see 4.2).

NOTE 2 These tests are classified as sample tests. The following guidance applies to type testing.

If a cable conforms to the requirements for category F60 it is deemed to conform to the requirements for category F30 and the tests referred to in J.2.9.3 (see 17.6.3) do not need to be carried out.

If a cable conforms to the requirements for category F120 it is deemed to conform to the requirements for categories F60 and F30 and the tests referred to in J.2.9.4 (see 17.6.4) and J.2.9.3 (see 17.6.3) do not need to be carried out.

J.2.9.2 Category F2 (see 17.6.2)

For multicore power cables, the smallest conductor size with the smallest number of cores, and the largest conductor size with the largest number of cores should be tested.

For multicore auxiliary cables, the smallest conductor size with the smallest number of cores, and the largest conductor size with the largest number of cores should be tested.

J.2.9.3 Category F30 (see 17.6.3)

When category F30 is being claimed on 2 core, 3 core, 4 core or 5 core cables with a measured 20 mm overall diameter or above, the smallest conductor size with the smallest number of cores, and the largest conductor size with the largest number of cores of the range claimed should be tested. In addition the tests referred to in J.2.9.2 (for Category F2) (see 17.6.2) should be carried out.

When category F30 is being claimed on 7 core cables with a measured 20 mm overall diameter or above, any one cable in the range should be tested. In addition the tests referred to in J.2.9.2 (for Category F2) (see 17.6.2) should be carried out.

J.2.9.4 Category F60 (see 17.6.4)

When category F60 is being claimed on 2 core, 3 core, 4 core or 5 core cables with a measured 20 mm overall diameter or above, the smallest conductor size with the smallest number of cores, and the largest conductor size with the largest number of cores of the range claimed should be tested. In addition the tests referred to in J.2.9.2 (for Category F2) (see 17.6.2) should be carried out.

When category F60 is being claimed on 7 core cables with a measured 20 mm overall diameter or above, any one cable in the range should be tested. In addition the tests referred to in J.2.9.2 (for Category F2) (see 17.6.2) should be carried out.

J.2.9.5 Category F120 (see 17.6.5)

When category F120 is being claimed on 2 core, 3 core, 4 core or 5 core cables with a measured 20 mm overall diameter or above, the smallest conductor size with the smallest number of cores, and the largest conductor size with the largest number of cores of the range claimed should be tested. In addition the tests referred to in J.2.9.2 (for Category F2) (see 17.6.2) should be carried out.

When category F120 is being claimed on 7 core cables with a measured 20 mm overall diameter or above, any one cable in the range should be tested. In addition the tests referred to in J.2.9.2 (for Category F2) (see 17.6.2) should be carried out.

J.2.10 Compatibility test (see 18.3)

One test should be performed on each cable selected.

J.2.11 Shrinkage test on insulation (see 18.4)

One test should be performed on each cable selected.

J.2.12 Length of lay of assembled cores (see 17.2)

NOTE This test is classified as a sample test. The guidance given below applies to type testing.

One test should be performed on each cable selected.

J.2.13 Length of lay of armour wires (see 17.3)

NOTE This test is classified as a sample test. The guidance given below applies to type testing.

One test should be performed on each cable selected.

J.2.14 Abrasion test (see 18.5)

One test should be performed on each cable selected.

J.2.15 Insulation resistance constant of oversheath (see 18.6)

One test should be performed on each cable selected.

J.2.16 Flame propagation on multiple cables (see 18.8)

For conformity to the recommendations of BS EN 60332-3-24:2009, Annex B, two possible methods of installation are stated, i.e. in spaced and touching formations. One size of multicore cable having a diameter not exceeding 15 mm should therefore be selected and tested in touching formation and one having a diameter between 26 mm and 40 mm (providing that at least two samples are used) and tested in spaced formation for conformity to the recommendations of BS EN 60332-3-24:2009, Annex B.

If the range of cables covered does not exceed a conductor size of 35 mm², the smallest and the largest in the range should be tested.

J.3 Change of material

The tests referred to in J.2 assume that the materials are consistent throughout the range of cables for which conformity is to be confirmed. Where a change occurs, additional testing should be included to ensure that such changes are adequately examined.

J.4 Evidence of type testing

When evidence of type testing is required, this should be stated at the enquiry stage. Because of the possible variations in cable designs, it should not be assumed that full type test information will be available for the size and type of cable in a particular enquiry.

A certificate of type test signed by the representative of a competent witnessing body, or a report authorized report by the manufacturer giving the test results, is acceptable.

Bibliography

Standards publications

For dated references, only the edition cited applies. For undated references, the latest edition of the referenced document (including any amendments) applies.

BS 5099, *Electric cables – Voltage levels for spark testing*

BS 7846:2009, *Electric cables – Thermosetting insulated, armoured, fire-resistant cables of rated voltage 600/1000 V, having low emission of smoke and corrosive gases when affected by fire – Specification*

BS 8512, *Electric cables – Code of practice for the storage, handling, installation and disposal of cables on wooden drums*

BS 8519:2010, *Selection and installation of fire-resistant power and control cable systems for life safety and fire-fighting applications – Code of practice*

BS 8573:2012, *Electric cables – Thermosetting insulated, non-armoured cables with a voltage of 600/1 000V, for fixed installations, having low emissions of smoke and corrosive gases when affected by fire*

BS EN 50265-2-1, *Common test methods for cables under fire conditions – Test for resistance to vertical flame propagation for a single insulated conductor or cable – Procedures – Part 2: 1 kW pre-mixed flame – Section 1: 1 kW pre-mixed flame*

BS EN 50266-2-4, *Common test methods for cables under fire conditions – Test for vertical flame spread of vertically-mounted bunched wires or cables – Procedures – Part 2: Category C*

BS EN 50356, *Method for spark testing of cables*

BS EN 50393, *Test methods and requirements for accessories for use on distribution cables of rated voltage 0,6/1,0 (1,2) kV*

BS EN 60079-14, *Explosive atmospheres – Part 14: Electrical installations design, selection and erection*

BS EN 61914, *Cable cleats for electrical installations*

BS EN 62275, *Cable management systems – Cable ties for electrical installations*

BS EN 62444, *Cable glands for electrical installations*

IEC 60183, *Guidance for the selection of high-voltage A.C. cable systems*

Other publications

[1] GREAT BRITAIN. The Electricity Safety, Quality and Continuity Regulations 2002. London: The Stationery Office.

British Standards Institution (BSI)

BSI is the national body responsible for preparing British Standards and other standards-related publications, information and services.

BSI is incorporated by Royal Charter. British Standards and other standardization products are published by BSI Standards Limited.

About us

We bring together business, industry, government, consumers, innovators and others to shape their combined experience and expertise into standards-based solutions.

The knowledge embodied in our standards has been carefully assembled in a dependable format and refined through our open consultation process. Organizations of all sizes and across all sectors choose standards to help them achieve their goals.

Information on standards

We can provide you with the knowledge that your organization needs to succeed. Find out more about British Standards by visiting our website at bsigroup.com/standards or contacting our Customer Services team or Knowledge Centre.

Buying standards

You can buy and download PDF versions of BSI publications, including British and adopted European and international standards, through our website at bsigroup.com/shop, where hard copies can also be purchased.

If you need international and foreign standards from other Standards Development Organizations, hard copies can be ordered from our Customer Services team.

Subscriptions

Our range of subscription services are designed to make using standards easier for you. For further information on our subscription products go to bsigroup.com/subscriptions.

With **British Standards Online (BSOL)** you'll have instant access to over 55,000 British and adopted European and international standards from your desktop. It's available 24/7 and is refreshed daily so you'll always be up to date.

You can keep in touch with standards developments and receive substantial discounts on the purchase price of standards, both in single copy and subscription format, by becoming a **BSI Subscribing Member**.

PLUS is an updating service exclusive to BSI Subscribing Members. You will automatically receive the latest hard copy of your standards when they're revised or replaced.

To find out more about becoming a BSI Subscribing Member and the benefits of membership, please visit bsigroup.com/shop.

With a **Multi-User Network Licence (MUNL)** you are able to host standards publications on your intranet. Licences can cover as few or as many users as you wish. With updates supplied as soon as they're available, you can be sure your documentation is current. For further information, email bsmusales@bsigroup.com.

BSI Group Headquarters

389 Chiswick High Road London W4 4AL UK

Revisions

Our British Standards and other publications are updated by amendment or revision.

We continually improve the quality of our products and services to benefit your business. If you find an inaccuracy or ambiguity within a British Standard or other BSI publication please inform the Knowledge Centre.

Copyright

All the data, software and documentation set out in all British Standards and other BSI publications are the property of and copyrighted by BSI, or some person or entity that owns copyright in the information used (such as the international standardization bodies) and has formally licensed such information to BSI for commercial publication and use. Except as permitted under the Copyright, Designs and Patents Act 1988 no extract may be reproduced, stored in a retrieval system or transmitted in any form or by any means – electronic, photocopying, recording or otherwise – without prior written permission from BSI. Details and advice can be obtained from the Copyright & Licensing Department.

Useful Contacts:

Customer Services

Tel: +44 845 086 9001

Email (orders): orders@bsigroup.com

Email (enquiries): cservices@bsigroup.com

Subscriptions

Tel: +44 845 086 9001

Email: subscriptions@bsigroup.com

Knowledge Centre

Tel: +44 20 8996 7004

Email: knowledgecentre@bsigroup.com

Copyright & Licensing

Tel: +44 20 8996 7070

Email: copyright@bsigroup.com



...making excellence a habit.™