

Methods of test for full-flow lubricating oil filters for internal combustion engines —

Part 12: Filtration efficiency using particle counting, and contaminant retention capacity

ICS 21.260; 27.020

Confirmed June 2011

National foreword

This British Standard reproduces verbatim ISO 4548-12:2000 and implements it as the UK national standard.

The UK participation in its preparation was entrusted by Technical Committee MCE/21, Filters for gases and liquids, to Subcommittee MCE/21/5, Filters for lubricating oil, which has the responsibility to:

- aid enquirers to understand the text;
- present to the responsible international/European committee any enquiries on the interpretation, or proposals for change, and keep the UK interests informed;
- monitor related international and European developments and promulgate them in the UK.

A list of organizations represented on this subcommittee can be obtained on request to its secretary.

Cross-references

The British Standards which implement international publications referred to in this document may be found in the BSI Standards Catalogue under the section entitled “International Standards Correspondence Index”, or by using the “Find” facility of the BSI Standards Electronic Catalogue.

A British Standard does not purport to include all the necessary provisions of a contract. Users of British Standards are responsible for their correct application.

Compliance with a British Standard does not of itself confer immunity from legal obligations.

Summary of pages

This document comprises a front cover, an inside front cover, the ISO title page, pages ii to v, a blank page, pages 1 to 26, an inside back cover and a back cover.

The BSI copyright notice displayed in this document indicates when the document was last issued.

This British Standard, having been prepared under the direction of the Engineering Sector Committee, was published under the authority of the Standards Committee and comes into effect on 15 May 2000

© BSI 05-2000

ISBN 0 580 34284 0

Amendments issued since publication

Amd. No.	Date	Comments

INTERNATIONAL STANDARD

BS 7403-12:2000
ISO
4548-12

First edition
2000-02-15

Methods of test for full-flow lubricating oil filters for internal combustion engines —

Part 12: Filtration efficiency using particle counting, and contaminant retention capacity

*Méthodes d'essai des filtres à huile de lubrification à plein débit pour les
moteurs à combustion interne —*

*Partie 12: Efficacité de filtration par comptage des particules et capacité de
rétention des contaminants*



Reference number
ISO 4548-12:2000(E)

Contents

Page

Foreword.....	iv
Introduction	v
1 Scope	1
2 Normative references	1
3 Terms and definitions	2
4 Symbols	2
5 Equipment	2
6 Materials	5
7 Accuracy of measuring instruments and test conditions	5
8 Test rig validation	5
9 Preliminary preparation	7
10 Test procedure	9
11 Calculations.....	11
12 Test report	13
Annex A (normative) Specification of test fluid for oil filter test	14
Annex B (informative) Typical filter test report	16
Annex C (normative) Filter efficiency calculations.....	22
Bibliography	26

Foreword

ISO (the International Organization for Standardization) is a worldwide federation of national standards bodies (ISO member bodies). The work of preparing International Standards is normally carried out through ISO technical committees. Each member body interested in a subject for which a technical committee has been established has the right to be represented on that committee. International organizations, governmental and non-governmental, in liaison with ISO, also take part in the work. ISO collaborates closely with the International Electrotechnical Commission (IEC) on all matters of electrotechnical standardization.

International Standards are drafted in accordance with the rules given in the ISO/IEC Directives, Part 3.

Draft International Standards adopted by the technical committees are circulated to the member bodies for voting. Publication as an International Standard requires approval by at least 75 % of the member bodies casting a vote.

Attention is drawn to the possibility that some of the elements of this part of ISO 4548 may be the subject of patent rights. ISO shall not be held responsible for identifying any or all such patent rights.

International Standard ISO 4548-12 was prepared by Technical Committee ISO/TC 70, *Internal combustion engines*, Subcommittee SC 7, *Tests for lubricating oil filters*.

ISO 4548 consists of the following parts, under the general title *Methods of test for full-flow lubricating oil filters for internal combustion engines*:

- *Part 1: Differential pressure/flow characteristics*
- *Part 2: Element by-pass valve characteristics*
- *Part 3: Resistance to high differential pressure and to elevated temperature*
- *Part 4: Initial particle retention efficiency, life and cumulative efficiency (gravimetric method)*
- *Part 5: Cold start simulation and hydraulic pulse durability test*
- *Part 6: Static burst pressure test*
- *Part 7: Vibration fatigue test*
- *Part 9: Inlet and outlet anti-drain valve tests*
- *Part 10: Life and cumulative efficiency in the presence of water in oil*
- *Part 11: Self-cleaning filters*
- *Part 12: Filtration efficiency using particle counting, and contaminant retention capacity*

Annexes A and C form a normative part of this part of ISO 4548. Annex B is for information only.

Introduction

ISO 4548 establishes standard test procedures for measuring the performance of full-flow lubricating oil filters for internal combustion engines. It has been prepared in separate parts, each part relating to a particular performance characteristic.

Together the tests provide the information necessary to assess the characteristics of a filter, but if agreed between the purchaser and the manufacturer, the tests may be conducted separately.

Methods of test for full-flow lubricating oil filters for internal combustion engines —

Part 12:

Filtration efficiency using particle counting, and contaminant retention capacity

1 Scope

This part of ISO 4548 specifies a multi-pass filtration test with continuous contaminant injection and using the on-line particle counting method for evaluating the performance of full-flow lubricating oil filters for internal combustion engines.

The test procedure determines the contaminant capacity of a filter, its particulate removal characteristics and differential pressure.

This test is intended for application to filter elements having a rated flow between 4 l/min and 600 l/min and with an efficiency of less than 99 % at a particle size greater than 10 μm .

NOTE Several test flow loops built into one test rig, or several test rigs, would be required to cover the complete flow range of 4 l/min to 600 l/min.

2 Normative references

The following normative documents contain provisions which, through reference in this text, constitute provisions of this part of ISO 4548. For dated references, subsequent amendments to, or revisions of, any of these publications do not apply. However, parties to agreements based on this part of ISO 4548 are encouraged to investigate the possibility of applying the most recent editions of the normative documents indicated below. For undated references, the latest edition of the normative document referred to applies. Members of ISO and IEC maintain registers of currently valid International Standards.

ISO 1219-1:1991, *Fluid power systems and components — Graphic symbols and circuit diagrams — Part 1: Graphic symbols*.

ISO 2942:1994, *Hydraulic fluid power — Filter elements — Verification of fabrication integrity and determination of the first bubble point*.

ISO 3968:1981, *Hydraulic fluid power — Filters — Evaluation of pressure drop versus flow characteristics*.

ISO 4021:1992, *Hydraulic fluid power — Particulate contamination analysis — Extraction of fluid samples from lines of an operating system*.

ISO 4405:1991, *Hydraulic fluid power — Fluid contamination — Determination of particulate contamination by the gravimetric method*.

BS 7403-12:2000

ISO 11171:1999, *Hydraulic fluid power — Calibration of automatic particle counters for liquids.*

ISO 11841-1:—¹⁾, *Road vehicles and internal combustion engines — Filter vocabulary — Part 1: Definitions of filters and filter components.*

ISO 11841-2:—¹⁾, *Road vehicles and internal combustion engines — Filter vocabulary — Part 2: Definitions of characteristics of filters and their components.*

ISO 11943:1999, *Hydraulic fluid power — On-line automatic particle-counting systems for liquids — Methods of calibration and validation.*

ISO 12103-1:1997, *Road vehicles — Test dust for filter evaluation — Part 1: Arizona test dust.*

3 Terms and definitions

For the purposes of this part of ISO 4548, the terms and definitions given in ISO 11841-1 and ISO 11841-2, together with the following, apply.

3.1

multi-pass test

test which requires the recirculation of unfiltered fluid through the filter element

3.2

base upstream gravimetric level

upstream contaminant concentration if no contaminant is recirculated

3.3

filtration efficiency

ability of the filter to retain particles expressed as the percentage of particles of a given size retained by the filter under test

3.4

overall efficiency

efficiency calculated from the average upstream and downstream particle counts

3.5

X % micron²) (μm) rating

particle size, in micrometres, corresponding to an overall efficiency of a given percentage X

4 Symbols

The graphical symbols used in this part of ISO 4548 are in accordance with ISO 1219-1.

5 Equipment

5.1 Test rig

The test rig shall comprise a filter test circuit and a contaminant injection circuit, as described in 5.1.1 and 5.1.2. See Figure 1.

1) To be published.

2) 1 micron \equiv 1 micrometre.

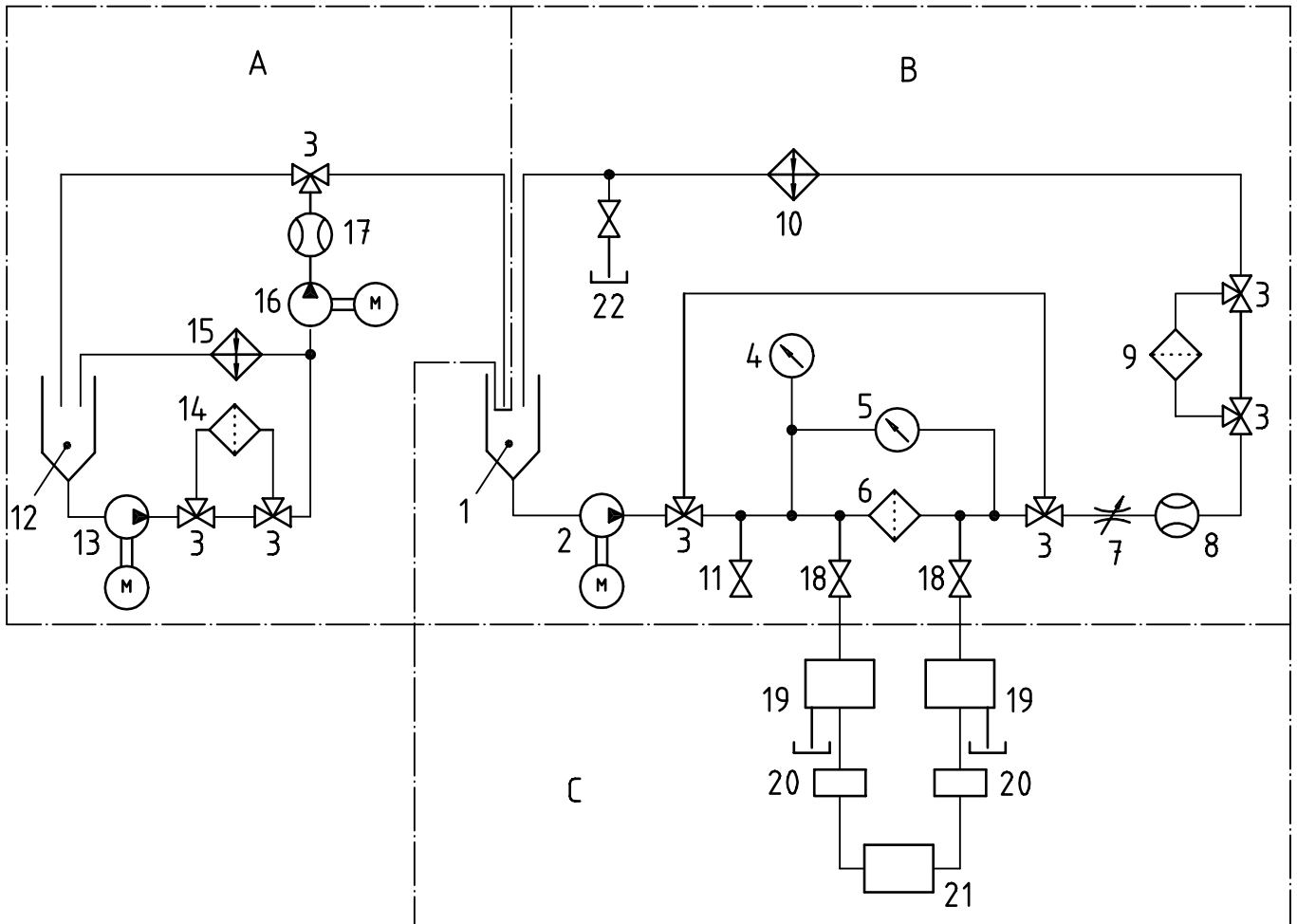
**Key**

- | | |
|--|---|
| 1 Reservoir incorporating a thermostatically controlled heater | 12 Reservoir incorporating a thermostatically controlled heater |
| 2 Pump | 13 Pump |
| 3 Three-way valve | 14 Clean-up filter |
| 4 Pressure gauge | 15 Heat exchanger |
| 5 Differential pressure gauge | 16 Injection pump |
| 6 Test filter | 17 Flow meter |
| 7 Throttle valve (for pressure regulation) | 18 Sampling valve |
| 8 Flow meter | 19 Dilution system |
| 9 Clean-up filter | 20 Particle sensor |
| 10 Heat exchanger | 21 Particle counter |
| 11 Sampling valve | 22 Volume control valve |
- A Contaminant injection circuit
 B Filter test circuit
 C Dilution and counting system

Figure 1 — Diagrammatic arrangement of test rig

5.1.1 Filter test circuit

The filter test circuit shall include the following components.

- a) Reservoir (1) constructed with a conical bottom having an included angle of not more than 90° and where the oil entering is diffused below the fluid surface.
- b) Oil pump (2) which does not alter the contaminant particle size distribution and which does not exhibit excessive flow pulses.
- c) Device, such as a filter head to accommodate spin-on filters, to connect the test filter (6) which can be by-passed or replaced by a straight section of pipe.
- d) System clean-up filter (9) capable of providing an initial system contamination level of less than 15 particles greater than 10 µm/ml.
- e) Sampling valves in accordance with ISO 4021, for turbulent sampling upstream and downstream of the test filter, for on-line particle counting (18) and for gravimetric analysis (11).
- f) Pressure tappings in accordance with ISO 3968.
- g) Piping sized to ensure that turbulent mixing conditions exist throughout the filter test circuit.

5.1.2 Contaminant injection circuit

The contaminant injection circuit shall include the following components:

- a) Reservoir (12) constructed with a conical bottom having an included angle of not more than 90° and where the oil entering is diffused below the fluid surface.
- b) Oil pump (13), centrifugal or of another type which does not alter the contaminant particle size distribution.
- c) System clean-up filter (14) capable of providing either of the following conditions:
 - 1) an initial system contamination level of less than 1 000 particles/ml having a size greater than 10 µm;
 - 2) a gravimetric level less than 2 % of the calculated level at which the test is being conducted, measured in accordance with the double membrane gravimetric method described in ISO 4405.
- d) Piping sized to ensure that turbulent mixing conditions exist throughout the contaminant injection circuit.

5.2 On-line dilution and particle counting system

The on-line dilution and particle counting system shall include the following components:

- a) On-line sample delivery pipework sized to maintain a fluid velocity which will prevent silting.
- b) Dilution system (19) comprising a reservoir, pump, clean-up filters, flowmeters and flow regulation valves.
- c) Two optical particle sensors (20) connected to a counter (21) having a minimum of five channels.

5.3 Timer, capable of measuring minutes and seconds.

6 Materials

6.1 Test contaminant

6.1.1 Contaminant grade

The contaminant shall be in accordance with the specification given for ISO 12103-A3 medium grade test dust in ISO 12103-1:1997.

6.1.2 Contaminant preparation

The test dust shall be pre-dried in quantities no larger than 200 g for at least 1 h at $105\text{ °C} \pm 5\text{ °C}$, cooled to room temperature and maintained in a desiccator until required for use.

6.2 Test fluid, having a petroleum base and conforming to the specifications given in annex A.

7 Accuracy of measuring instruments and test conditions

The measuring instruments shall be capable of measuring to the levels of accuracy given in Table 1. The last column in the table gives the limits within which the test conditions shall be maintained.

Table 1 — Instrument accuracy and test condition variation

Test condition	Units	Measurement accuracy	Allowed test condition variation
Flow	l/min	$\pm 2\%$	$\pm 5\%$
Pressure	Pa	$\pm 5\%$	—
Temperature	°C	$\pm 1\text{ °C}$	$\pm 2\text{ °C}$
Volume	l	$\pm 5\%$	$\pm 10\%$
Base upstream gravimetric level	mg/l	—	$\pm 1\text{ mg/l}$
Conductivity	pS/m	$\pm 10\%$	
Viscosity ^a	mm ² /s	$\pm 5\%$	

^a The viscosity of the test liquid should be checked at regular intervals to ensure that the test is conducted at a liquid temperature which corresponds to a viscosity of $15\text{ mm}^2/\text{sec} \pm 1\text{ mm}^2/\text{sec}$.

8 Test rig validation

NOTE These validation procedures reveal the effectiveness of the test rig in maintaining contaminant entrainment and/or preventing contaminant size modification.

8.1 Validation of filter test circuit

8.1.1 Validate the filter test circuit at the minimum flow rate at which the circuit will be operated. Install a straight section of pipe in place of a test filter during the validation procedure.

8.1.2 For flows of less than 60 l/min, adjust the total circuit volume to be numerically equal to one-half of the value of the minimum flow volume per minute through the filter, with a minimum of 6 l. For flows higher than 60 l/min, adjust the total circuit volume to be numerically equal to one-quarter of the value of the minimum flow volume per minute through the filter.

8.1.3 Contaminate the fluid to the calculated gravimetric level of 5 mg/l using ISO 12103-A3 test dust.

NOTE This contamination level is below the coincidence limit of automatic particle counters.

8.1.4 Circulate the fluid in the test system for 1 h whilst obtaining downstream cumulative counts at 10 µm and 20 µm without on-line dilution at 10 min sample intervals.

8.1.5 Calculate and record the on-line count (C_o) in particles/ml, using the equation

$$C_o = \frac{N_c}{V}$$

where

N_c is the cumulative count for the selected sample period, in number of particles;

V is the volume of fluid, in millilitres, passed through the particle counter sensor during the sample period.

8.1.6 Accept the validation test only if:

- each particle count obtained at 10 µm and 20 µm does not deviate by more than 10 % from the average particle counts for these sizes;
- the average for all particle counts per millilitre at channel > 10 µm is not less than 750 nor more than 1 000;
- the particle counts per millilitre at channel > 20 µm are not less than 70 nor more than 120.

8.2 Validation of contaminant injection circuit

8.2.1 Validate the contaminant injection circuit at the maximum volume and the maximum gravimetric level to be used.

8.2.2 Add the required quantity of contaminant in a slurry form to the injection circuit fluid and circulate for sufficient time to completely disperse the contaminant.

NOTE All systems may not disperse contaminant at the same rate. A period of 10 min to 20 min may be necessary for complete dispersion.

8.2.3 Extract fluid samples at the point where the injection fluid is discharged into the filter test circuit reservoir at 30 min intervals over 2 h and analyse each sample gravimetrically.

NOTE These samples should be taken at the intended test injection flow rate.

8.2.4 Accept the validation test only if the gravimetric level of each sample is within ± 5 % of the average of the four samples and if this average is within ± 5 % of the gravimetric level selected in 8.2.1.

8.3 Validation of on-line dilution and particle counting system

Proceed as described in ISO 11943 to validate the on-line dilution system and proceed in accordance with ISO 11171 to validate the particle counter.

9 Preliminary preparation

9.1 Test filter assembly

9.1.1 Ensure that the test fluid cannot by-pass the filter element to be evaluated. Unless agreed between the purchaser and manufacturer, the by-pass valve of the filter element shall be kept operative. If the by-pass valve has been made inoperative, this shall be clearly stated in the test report.

9.1.2 Subject the test filter element to a fabrication integrity test in accordance with ISO 2942 using MIL-H-5606 fluid prior to the multi-pass test or following the multi-pass test if the element is not readily accessible as in the spin-on configuration.

9.1.3 If the integrity test has been carried out prior to the multi-pass test and if it fails to meet the test pressure agreed between the purchaser and the manufacturer, disqualify the element from further testing. If the integrity test has been carried out after the multi-pass test and if it fails, disqualify the test result.

9.2 Contaminant injection circuit

9.2.1 Using 10 mg/l as the base upstream gravimetric level, calculate the predicted test time, (T_e), in minutes using the equation:

$$T_e = \frac{F_c}{G \times Q} = \frac{F_c}{10 \times Q}$$

where

F_c is the estimated capacity of the filter element, in milligrams;

G is the base upstream gravimetric level, in milligrams per litre;

Q is the test flow rate, in litres per minute.

NOTE 1 A test duration of more than 30 min is recommended.

NOTE 2 If the estimated capacity of the filter element (F_c) is not supplied by the manufacturer, it may be necessary to determine the capacity by testing an element.

NOTE 3 The base upstream gravimetric level (G) of 10 mg/l should be adhered to unless otherwise agreed upon by the purchaser and the manufacturer. Base upstream gravimetric levels up to 25 mg/l may be used to shorten test times but only the results of filter tests using the same base upstream gravimetric level can be compared.

9.2.2 Calculate the minimum volume of fluid (V_m) in litres, required for the operation of the injection circuit, which is compatible with the predicted test time and an injection flow rate of 0,25 l/min, using the equation:

$$V_m = 1,2T_e \times Q_i + V_0$$

where

T_e is the predicted test time, in minutes, obtained in 9.2.1;

Q_i is the injection flow rate, in litres per minute;

V_0 is the minimum volume of fluid, in litres, in the injection circuit necessary to avoid air entrainment.

NOTE 1 The calculated minimum volume should ensure a sufficient quantity of contaminant fluid to load the element, plus 20 % for adequate circulation throughout the test and to avoid entrainment. Larger injection volumes may be used.

NOTE 2 It is strongly recommended to use an injection flow rate of 0,25 l/min. Higher injection flow rates may be used if they are less than 4 % of the test flow rate, in order to minimize the effects of extraction on the filter capacity. Lower injection rates may be used if the system is validated in accordance with ISO 11943. In all cases, the flow rates extracted for dilution and counting upstream and downstream should each be 50 % of the injection flow rate, or as balanced using the downstream volume control valve (22) shown in Figure 1.

9.2.3 Calculate the gravimetric level (G_i) in mg/l of the injection fluid, using the equation:

$$G_i = \frac{G \times Q}{Q_i} = \frac{10Q}{Q_i}$$

where

G is the base upstream gravimetric level, in milligrams per litre, established in 9.2.1;

Q is the test flow rate, in litres per minute;

Q_i is the injection flow rate, in litres per minute.

9.2.4 Calculate the quantity of contaminant (W) in grams, needed for the contaminant injection circuit, using the equation:

$$W = \frac{G_i \times V_i}{1\ 000}$$

where

G_i is the gravimetric level, in milligrams per litre, obtained in 9.2.3;

V_i is the volume of fluid contained in the injection circuit, in litres.

9.2.5 Adjust the injection flow rate at stabilized temperature to within $\pm 5\%$ of the value selected in 9.2.2 and maintain throughout the test.

9.2.6 Circulate the fluid in the contaminant injection circuit through the clean-up filter (14) until either of the following conditions are attained:

- a) a contamination level of less than 1 000 particles per millilitre having a size greater than 10 μm ;
- b) a gravimetric level of less than 2 % of the value determined in 9.2.3.

9.2.7 By-pass the system clean-up filter (14) after the required initial contamination has been achieved.

9.2.8 Adjust the total volume of the contaminant injection system to the value determined in 9.2.2.

9.2.9 Ensure that the conductivity of the test fluid and the injection fluid is at least 1 000 pS/m by measuring fluid conductivity prior to each test.

NOTE A level of 1 500 pS/m \pm 500 pS/m is recommended. An initial level of 0,01 % of an antistatic agent has been shown to produce conductivity within this range.

9.2.10 Add, in slurry form to the contaminant injection circuit reservoir (12), the quantity of contaminant (W) determined in 9.2.4, and circulate until the contaminant is completely dispersed.

NOTE Complete dispersal of the contaminant may take between 10 min and 20 min.

9.3 Filter test circuit

9.3.1 Install a straight section of pipe in place of the test filter.

9.3.2 Circulate the fluid in the filter test circuit through the clean-up filter (9) until a contamination level of less than 15 particles per millilitre having a size greater than 10 µm is attained. Record this value as the initial cleanliness level of the system.

NOTE The contamination level should be checked with the on-line particle counting system which will, at the same time, clean the sampling lines.

9.3.3 Adjust the fluid volume of the filter test circuit to the value determined in 8.1.2 and record this value.

9.3.4 Ensure that the conductivity of the test fluid is at least 1 000 pS/m by measuring fluid conductivity prior to each test.

NOTE A level of 1 500 pS/m ± 500 pS/m is recommended. An initial level of 0,01 % of an antistatic agent has been shown to produce conductivity within this range.

9.3.5 Install the filter housing, without the test element, in the filter test circuit. For a spin-on type filter, install this spin-on filter body without an element inside.

9.3.6 Circulate the fluid in the filter test circuit at the rated flow and at the stabilized test temperature ± 2 °C. Measure and record the differential pressure of the empty filter housing (Δp_3).

9.3.7 Adjust the channels on the particle counter to read the following particle sizes:

— 5- (6) channel counter : (5), 10, 15, 20, 30, 40;

— 16-channel counter : 5, 6, 7, 8, 9, 10, 11, 13, 15, 17, 20, 25, 30, 35, 40, 50.

10 Test procedure

10.1 Initial measurement

10.1.1 Install the filter element (6) in its housing and subject the assembly to the flow rate required by the purchaser and to the temperature required to maintain an oil viscosity of 15 mm²/s ± 1 mm²/s. Recheck the fluid level.

10.1.2 Measure and record the differential pressure of the clean assembly (Δp_1).

10.1.3 Calculate and record the differential pressure of the clean element (Δp_2) using the equation:

$$\Delta p_2 = \Delta p_1 - \Delta p_3$$

where

Δp_1 is the differential pressure of the clean assembly measured in 10.1.2;

Δp_3 is the differential pressure of the empty filter housing measured in 9.3.6.

10.1.4 Calculate the differential pressures (Δp_5) corresponding to increases of 80 % and 100 % of the net differential pressure using the equation:

$$\Delta p_5 = \Delta p_4 - \Delta p_2$$

where

Δp_4 is the element terminal differential pressure;

Δp_2 is the differential pressure of the clean element obtained from 10.1.3.

NOTE For clarity, Δp_1 to Δp_6 are illustrated in Figure 2.

10.1.5 Obtain a fluid sample from the contaminant injection circuit, at the point where the fluid return pipe discharges into the reservoir (12).

10.1.6 Measure and record the injection flow rate.

10.1.7 Adjust the dilution at the start of the test to the anticipated maximum dilution required during the test to avoid particle counter saturation.

10.2 Performance test

10.2.1 By-pass the clean-up filter (9).

10.2.2 Allow the injection flow to enter the filter test circuit reservoir.

10.2.3 Start the timer.

10.2.4 Start the upstream and downstream sample flows.

10.2.5 Record the differential pressure and count particles upstream and downstream for 50 s every minute at the flow specified in the sensor.

10.2.6 Calculate and record the on-line count (C_o) using the equation:

$$C_o = \frac{N_c \times D}{V}$$

where

N_c is the cumulative count for the sample interval, in number of particles;

D is the dilution factor;

V is the volume of fluid passed through the particle counter sensor during the sample interval, in millilitres.

10.2.7 Record the test time, in minutes, required for the differential pressure across the filter assembly (Δp) to increase by 80 % and 100 % of the final net differential pressure (Δp_5).

10.2.8 Take an upstream sample at valve (11) for gravimetric analysis when the differential pressure across the filter assembly has increased by 80 % of the net differential pressure.

NOTE The sample is taken at the 80 % point because it often overlaps the 100 % point.

10.2.9 Stop the flow to the test filter and measure and record the exact final volume of test fluid (V_f).

NOTE If 100 % net differential pressure is reached during sampling, complete sampling before stopping the flow to the test filter.

10.2.10 Accept the test if the final volume (V_f) is within ± 10 % of the initial volume.

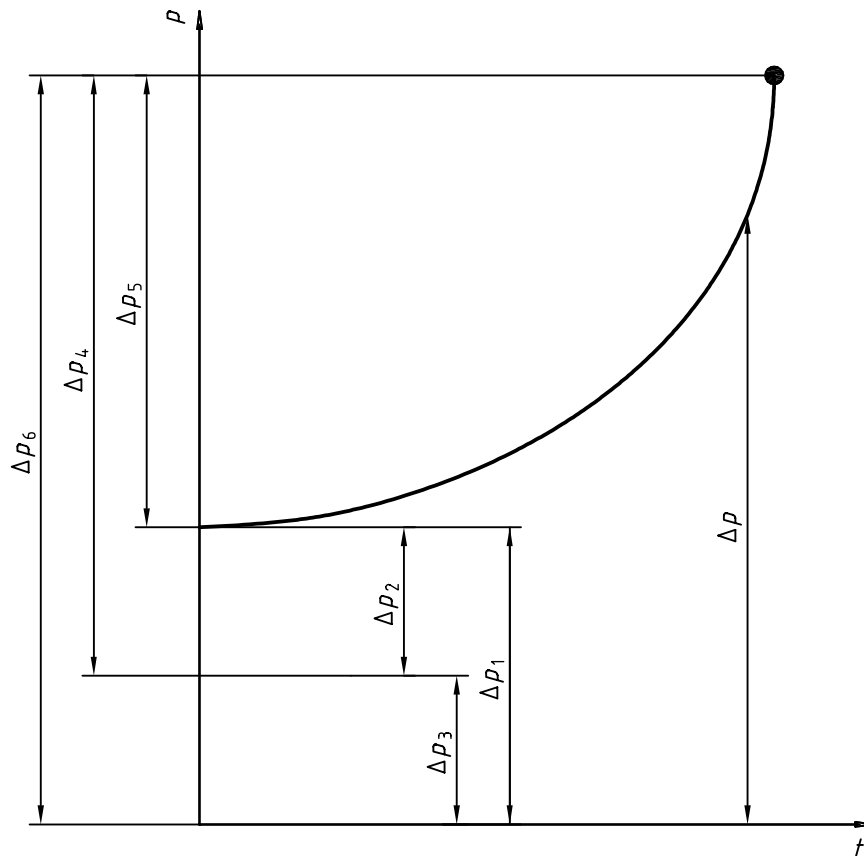

Key

- Δp Measured differential pressure
- Δp_1 Differential pressure of the clean assembly
- Δp_2 Differential pressure of the clean element
- Δp_3 Differential pressure of the housing
- Δp_4 Terminal differential pressure of the element
- Δp_5 Final net differential pressure
- Δp_6 Differential pressure across the filter assembly at the end of the test

Figure 2 — Diagrammatic representation of filter differential pressures

10.2.11 Obtain a final fluid sample from the contaminant injection circuit at the point where the injection fluid is discharged into the filter test circuit.

10.2.12 Measure and record the final injection flow rate.

10.2.13 Remove the element and check that there is no visual evidence of filter damage as a result of performing this test.

11 Calculations

11.1 Gravimetric levels

11.1.1 Conduct a gravimetric analysis in accordance with ISO 4405 on the two samples extracted from the contaminant injection circuit (see 10.1.5 and 10.2.11) and on the upstream sample extracted from the filter test circuit at the 80 % sample point (see 10.2.8)

11.1.2 Take the non-retained contaminant concentration, in milligrams per litre, at the 80 % sample point and record it as the final system gravimetric level (G_f).

11.1.3 Calculate and record the average of the gravimetric levels (G_{ia}) for the two samples taken from the contaminant injection circuit in 10.1.5 and 10.2.11.

11.1.4 Accept the test only if the gravimetric level of each sample is within 10 % of the average G_{ia} calculated in 11.1.3.

11.1.5 Calculate and record the injection flow rate (Q_{ia}) by averaging the measurements taken in 10.1.6 and 10.2.12.

11.1.6 Accept the test only if the value of Q_{ia} is equal to the selected value $\pm 5\%$ (see 9.2.2).

11.1.7 Calculate and record the actual base upstream gravimetric level (G_a) in mg/l, using the equation:

$$G_a = \frac{G_{ia} \times Q_{ia}}{Q}$$

where

G_{ia} is the average injection gravimetric level, in milligrams per litre, obtained in 11.1.3;

Q_{ia} is the average injection flow rate, in litres per minute, obtained in 11.1.5;

Q is the test flow rate, in litres per minute.

11.1.8 Accept the test only if the base upstream gravimetric level (G_a) is equal to 10 mg/l ± 1 mg/l.

11.2 Filtration efficiencies

11.2.1 Average intermediate efficiencies

From the upstream and downstream particle counts recorded from each channel of the counter in 10.2.6, calculate the average intermediate efficiencies at each particle size, as described in C.1 and C.2.

Identify the maximum and minimum calculated intermediate efficiencies for each particle size and record them in the overall filtration efficiency table in the test report (see annex B).

11.2.2 Overall efficiencies

Calculate the overall efficiency, at each particle size, as described in C.3.

Record the calculated overall efficiency at each particle size in the overall filtration efficiency table in the test report (see annex B).

Prepare a graph of overall efficiency versus particle size, as shown in Figure B.4 and, if required by the purchaser, also provide a graph as shown in Figure B.5.

11.3 Micrometer ratings

The graph of overall efficiency versus particle size may highlight the particle sizes that correspond to overall efficiencies of 50 %, 75 % and 90 % as shown in Figure B.4. These particle sizes may also be recorded in the test report sheet.

Optionally, and only in the case of high efficiency filters, identify the particle sizes that correspond to overall efficiencies of 98,7 % and 99 %.

NOTE The particle sizes that correspond to overall efficiencies of 98,7 % and 99 % cannot be determined graphically with acceptable accuracy. These values should therefore be calculated by linear interpolation.

11.4 Injected mass of contaminant

Calculate the mass of contaminant injected into the filter element (M_i) in grams, using the equation:

$$M_i = Q_{ia} \times G_{ia} \times T / 1\,000$$

where

Q_{ia} is the average injection flow rate, in litres per minute, calculated in 11.1.5;

G_{ia} is the average gravimetric level of the injection fluid, in milligrams per litre, calculated in 11.1.3;

T is the time required to reach the terminal differential pressure, in minutes (see 10.2.7).

Record the calculated value of M_i in the test report.

11.5 Non-retained mass of contaminant

Calculate the non-retained mass of contaminant (M_{nr}) in grams, using the equation:

$$M_{nr} = V_f \times G_f / 1\,000$$

where

V_f is the final volume of test fluid, in litres, obtained in 10.2.9;

G_f is the final system gravimetric level, in milligrams per litre, obtained in 11.1.2.

Record the calculated value of M_{nr} in the test report.

11.6 Retained filter capacity

Calculate the retained filter capacity (C_r) in grams, using the equation.

$$C_r = M_i - M_{nr}$$

where

M_i is the mass of contaminant injected into the filter element, in grams, obtained in 11.4.

M_{nr} is the non-retained mass of contaminant, in grams, obtained in 11.5.

Record the calculated value of C_r in the test report.

NOTE The retained capacity as calculated here is an approximate value since it does not take into account the contaminant extracted upstream and downstream for particle counting.

12 Test report

A typical test report is given in annex B.

Annex A (normative)

Specification of test fluid for oil filter test ³⁾

A.1 Petroleum base stock

The petroleum base stock shall have the following properties.

- pour point: – 59,4 °C (minimum)
- flash point: 93,3 °C (minimum)
- acid or base number: 0,1 mg KOH/g(maximum)
- precipitation number: 0

A.2 Additives

The test fluid shall contain the following added materials.

- viscosity-temperature coefficient improver: 10 % (maximum)
- oxidation inhibitors: 2 % (maximum)
- tricresyl phosphoate anti-wear agent: 0,5 % ± 0,1 %

NOTE The free phenol content of the tricresyl phosphoate anti-wear agent should not exceed 0,05 %.

A.3 Properties

The test fluid shall have the following properties.

- viscosity at 40 °C: 13,2 mm²/s⁴⁾ (minimum)
- viscosity at – 40 °C: 500 mm²/s (minimum)
- pour point: – 59,4 °C (minimum)
- flash point: 93,3 °C (minimum)
- precipitation number: 0
- acid or base number: 0,2 mg KOH/g (maximum)

3) Suitable test fluids are aircraft hydraulic oils MIL-H-5606 and AIR 3520.

4) 1 mm²/s = 1 cSt.

A.4 Colour

The test fluid shall be clear and transparent. For identification it shall contain a red dye in a proportion not greater than one part of dye per 10 000 parts of oil.

Annex B (informative)

Typical filter test report

Typical test report sheets are illustrated in Figures B.1 and B.2. The test report should include the following additional information presented in graphical form:

- a graph of differential pressure with respect to time and mass of contaminant added, as illustrated in Figure B.3;
- a graph of overall efficiency with respect to particle size, as illustrated in Figure B.4.

If required by the purchaser, the manufacturer should also include a graph of overall efficiency with respect to particle size (semi-logarithmic presentation), as illustrated in Figure B.5.

TEST IDENTIFICATION

TEST DATE: TEST TIME:	TEST LOCATION: OPERATOR:	TEST ID: PROJECT:
--------------------------	-----------------------------	----------------------

FILTER IDENTIFICATION

FILTER ID: HOUSING TYPE:	BY-PASS VALVE OPERATIVE: YES/NO	FABRICATION INTEGRITY: (hPa) DATE OF MANUFACTURE:
-----------------------------	------------------------------------	--

OPERATING CONDITIONS

TEST FLUID	Type: Conductivity: (pS/m)	Viscosity: (mm ² /s) Temperature: (°C)
TEST DUST	Grade:	Batch No.:
INJECTION SYSTEM	Dust added W : (g) Volume V_i : (l) Injection flowrate Q_{ia} : (ml/min)	Injection grav. initial: (mg/l) Injection grav. final: (mg/l) Injection grav. average G_{ia} : (mg/l)
TEST SYSTEM	Flowrate Q : (l/min) Volume: (l) Final volume V_f : (l)	Initial cleanliness: (#>10 μ m/ml) Base gravimetric level G_a : (mg/l) Final gravimetric level G_f : (mg/l)
DILUTION SYSTEM	Sensor type: Flowrate: (ml/min) Upstream dilution ratio: Downstream dilution ratio:	Sample time: (s) Hold time: (s) Sampling time: (min) Number of counts to average: Total counts:

TEST RESULTS

	CLEAN ASSY Δp_1 : (kPa)			CLEAN ELEMENT Δp_2 : (kPa)			
	HOUSING Δp_3 : (kPa)			FINAL NET Δp_5 : (kPa)			
RELATIVE NET DIFFERENTIAL PRESSURE $\frac{\Delta p - \Delta p_1}{\Delta p_5}$	5	10	15	20	40	80	100
ASSY Δp (kPa)							
TEST TIME (min)							

OVERALL FILTRATION EFFICIENCY

Particle size	> 5 μ m	> 6 μ m	> 7 μ m	> 8 μ m	> 9 μ m	> 10 μ m	> 11 μ m	> 13 μ m
Max. Eff. (%)								
Min. Eff. (%)								
Overall Eff. (%)								
Particle size	> 15 μ m	> 17 μ m	> 20 μ m	> 25 μ m	> 30 μ m	> 35 μ m	> 40 μ m	> 50 μ m
Max. Eff. (%)								
Min. Eff. (%)								
Overall Eff. (%)								

Efficiency (%):	50	75	90	98,7 ^{a)}	99 ^{a)}
Micrometer rating (μ m):					

^{a)} Optional, and only in the case of high efficiency filters.

Injected mass M_i : (g)	Non retained mass M_{nr} : (g)	Retained capacity C_r : (g)
---------------------------	----------------------------------	-------------------------------

Figure B.1 — Test report sheet

TEST DATE:	TEST LOCATION:	TEST ID:
TEST TIME:	OPERATOR:	PROJECT:

FILTRATION EFFICIENCY — ELAPSED TIME: (min); DIFF. PRESSURE: (kPa)								
Particle size	> 5 µm	> 6 µm	> 7 µm	> 8 µm	> 9 µm	> 10 µm	> 11 µm	> 13 µm
UPSTREAM								
DOWNSTREAM								
EFFICIENCY %								
Particle size	> 15 µm	> 17 µm	> 20 µm	> 25 µm	> 30 µm	> 35 µm	> 40 µm	> 50 µm
UPSTREAM								
DOWNSTREAM								
EFFICIENCY %								

FILTRATION EFFICIENCY — ELAPSED TIME: (min); DIFF. PRESSURE: (kPa)								
Particle size	> 5 µm	> 6 µm	> 7 µm	> 8 µm	> 9 µm	> 10 µm	> 11 µm	> 13 µm
UPSTREAM								
DOWNSTREAM								
EFFICIENCY %								
Particle size	> 15 µm	> 17 µm	> 20 µm	> 25 µm	> 30 µm	> 35 µm	> 40 µm	> 50 µm
UPSTREAM								
DOWNSTREAM								
EFFICIENCY %								

FILTRATION EFFICIENCY — ELAPSED TIME: (min); DIFF. PRESSURE: (kPa)								
Particle size	> 5 µm	> 6 µm	> 7 µm	> 8 µm	> 9 µm	> 10 µm	> 11 µm	> 13 µm
UPSTREAM								
DOWNSTREAM								
EFFICIENCY %								
Particle size	> 15 µm	> 17 µm	> 20 µm	> 25 µm	> 30 µm	> 35 µm	> 40 µm	> 50 µm
UPSTREAM								
DOWNSTREAM								
EFFICIENCY %								

FILTRATION EFFICIENCY — ELAPSED TIME: (min); DIFF. PRESSURE: (kPa)								
Particle size	> 5 µm	> 6 µm	> 7 µm	> 8 µm	> 9 µm	> 10 µm	> 11 µm	> 13 µm
UPSTREAM								
DOWNSTREAM								
EFFICIENCY %								
Particle size	> 15 µm	> 17 µm	> 20 µm	> 25 µm	> 30 µm	> 35 µm	> 40 µm	> 50 µm
UPSTREAM								
DOWNSTREAM								
EFFICIENCY %								

Figure B.2 — Presentation of test results

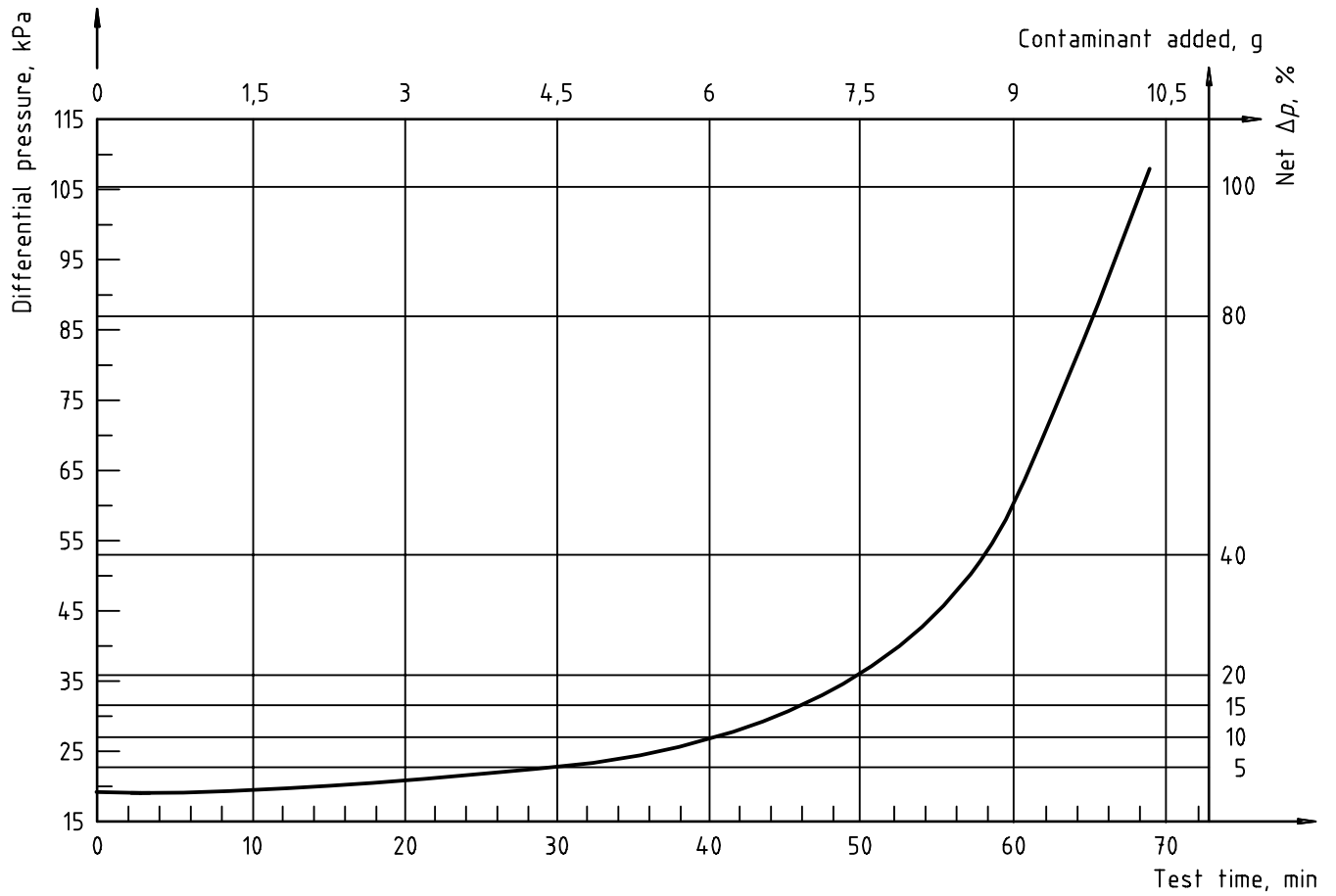

Figure B.3 — Graph of differential pressure versus test time

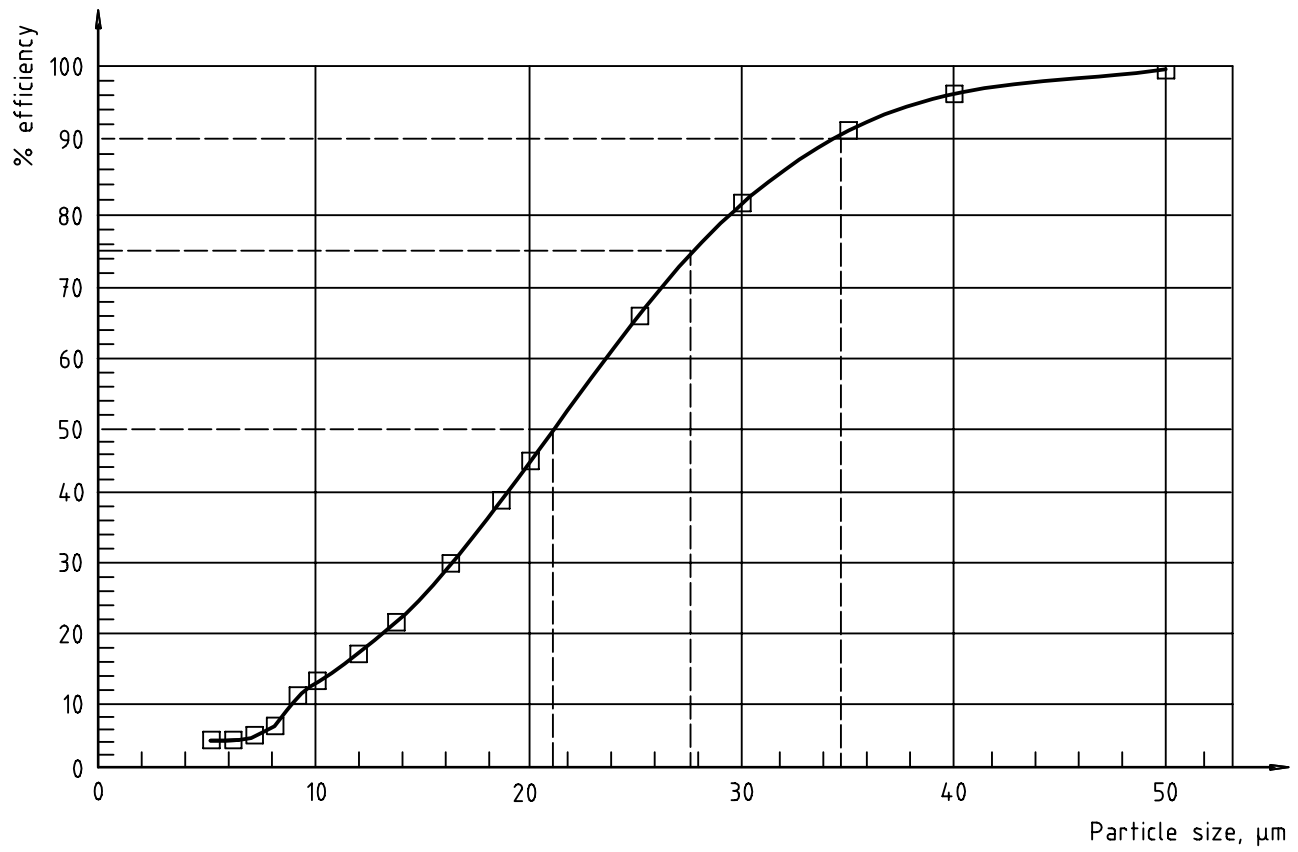

Figure B.4 — Graph of overall efficiency versus particle size

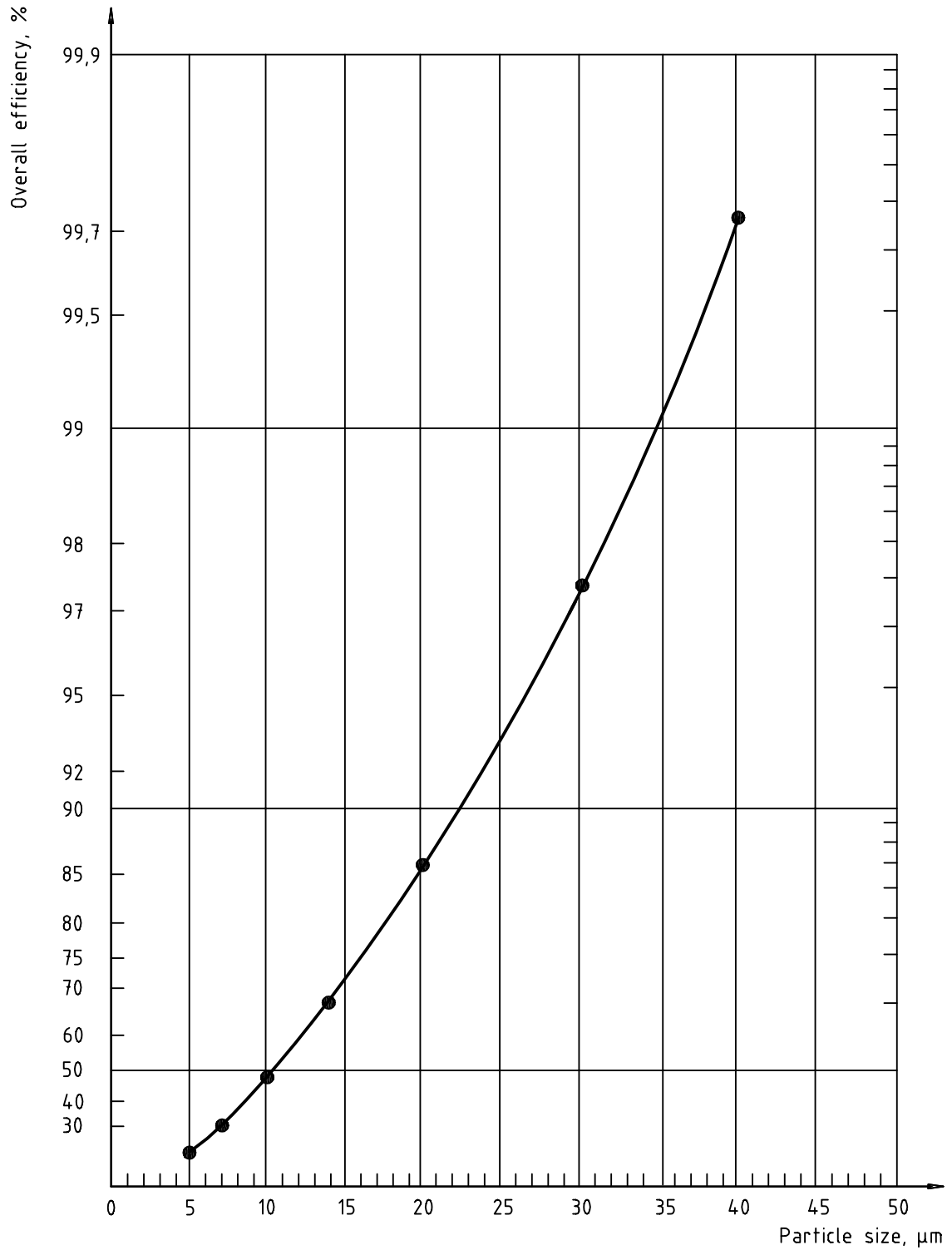

Figure B.5 — Graph of overall efficiency versus particle size (semi-logarithmic presentation)

Annex C (normative)

Filter efficiency calculations

C.1 General conditions

For the purpose of this example it is assumed that particles were counted at intervals of one minute, upstream and downstream, in 16 channels, for a test duration of 86 min. These example calculations relate to one channel in which the particle size was $> 20 \mu\text{m}$ and the readings taken at intervals of one minute were as shown in Table C.1.

Table C.1 — Particle counter readings in one channel

Time interval (min)	Particle count		Time interval (min)	Particle count	
	Upstream	Downstream		Upstream	Downstream
1	14,4	1,0	16	209,6	77,0
2	171,4	35,3	17	217,8	73,1
3	191,7	53,8	18	193,3	68,9
4	163,7	47,3	19	204,2	84,3
5	190,9	51,5	20	224,4	85,5
6	182,8	54,9	—	—	—
7	165,2	41,8	—	—	—
8	191,5	66,7	—	—	—
9	186,4	57,5	80	382,6	207,8
10	218,4	49,4	81	350,9	198,2
11	190,7	54,9	82	347,7	208,3
12	174,8	59,1	83	308,3	165,2
13	210,6	55,0	84	309,0	157,7
14	242,3	66,9	85	297,5	162,0
15	188,0	82,8	86	295,7	147,4

NOTE The readings taken at time intervals 21 min to 79 min have been omitted from the table since they are not relevant to the example calculations

C.2 Calculation of filter intermediate efficiencies

Intermediate efficiencies are calculated from the average particle counts, upstream and downstream, at either of the following time intervals:

- 5 min if the duration of the test did not exceed 1 h;
- 10 min if the duration of the test exceeded 1 h.

In the present example the duration of the test was 86 min. Therefore, the intermediate efficiencies are calculated for each 10 min interval.

C.2.1 First 10 min interval

In order to eliminate potentially erroneous particle counts obtained prior to stabilization of the system, the first three minutes of the test are disregarded.

The intermediate efficiency of the filter at the 10 min interval (E_{10}) is calculated using the equation.

$$E_{10} = \frac{C_{u10} - C_{d10}}{C_{u10}} \times 100$$

where

C_{u10} is the average of the upstream counts taken at the 4 min to 10 min intervals.

$$\left(\text{i.e. } \frac{163,7 + 190,9 \dots\dots\dots 218,4}{7} = 185,56 \right)$$

where

C_{d10} is the average of the downstream counts taken at the 4 min to 10 min intervals.

$$\left(\text{i.e. } \frac{47,3 + 51,5 \dots\dots\dots 49,4}{7} = 52,73 \right)$$

therefore

$$E_{10} = \frac{185,56 - 52,73}{185,56} \times 100 = 71,58 \%$$

C.2.2 Subsequent 10 min intervals

The intermediate efficiency is calculated for each of the subsequent 10 min intervals in accordance with the following example (E_{20}) which corresponds to the 20 min interval.

$$E_{20} = \frac{C_{u20} - C_{d20}}{C_{u20}} \times 100$$

where

C_{u20} is the average of the upstream counts taken at the 11 min to 20 min intervals.

$$\left(\text{i.e. } \frac{190,7 + 174,8 \dots\dots\dots 224,4}{10} = 205,57 \right)$$

where

C_{d20} is the average of the downstream counts taken at the 11 min to 20 min intervals.

$$\left(\text{i.e. } \frac{54,9 + 59,1 + \dots + 85,5}{10} = 70,75 \right)$$

therefore

$$E_{20} = \frac{205,57 - 70,75}{205,57} \times 100 = 65,58 \%$$

C.2.3 Final interval

The intermediate efficiency for the final interval of 6 min (i.e. period 81 min to 86 min) is calculated using the equation

$$E_{86} = \frac{C_{u86} - C_{d86}}{C_{u86}} \times 100$$

where

C_{u86} is the average of the upstream counts taken at the 81 min to 86 intervals.

$$\left(\text{i.e. } \frac{350,9 + 347,7 + \dots + 295,7}{6} = 318,18 \right)$$

where

C_{d86} is the average of the downstream counts taken at the 81 min to 86 min intervals.

$$\left(\text{i.e. } \frac{198,2 + 208,3 + \dots + 147,4}{6} = 173,13 \right)$$

Therefore

$$E_{86} = \frac{318,18 - 173,13}{318,18} \times 100 = 45,59 \%$$

C.3 Calculation of filter overall efficiencies

The overall efficiency of the filter at the $> 20 \mu\text{m}$ particle size, selected for this example, is calculated using the equation

$$E_{o20} = \frac{C_{uo20} - C_{do20}}{C_{uo20}} \times 100$$

where

C_{uo20} is the average of the upstream counts taken at the one minute intervals from 4 min to 86 min.

$$\left(\text{i.e. } \frac{163,7 + 190,9 + \dots + 295,7}{83} = 287,35 \right)$$

where

C_{do20} is the average of the downstream counts taken at intervals of one minute from 4 min to 86 min.

$$\left(\text{i.e. } \frac{47,3 + 51,5 + \dots + 147,4}{83} = 142,5 \right)$$

Therefore

$$E_{o20} = \frac{287,35 - 142,5}{287,35} \times 100 = 50,41\%$$

Bibliography

- [1] ASTM D-4308-95, *Standard Test Method for Electrical Conductivity of Liquid Hydrocarbons by Precision Meter.*

BSI — British Standards Institution

BSI is the independent national body responsible for preparing British Standards. It presents the UK view on standards in Europe and at the international level. It is incorporated by Royal Charter.

Revisions

British Standards are updated by amendment or revision. Users of British Standards should make sure that they possess the latest amendments or editions.

It is the constant aim of BSI to improve the quality of our products and services. We would be grateful if anyone finding an inaccuracy or ambiguity while using this British Standard would inform the Secretary of the technical committee responsible, the identity of which can be found on the inside front cover. Tel: 020 8996 9000. Fax: 020 8996 7400.

BSI offers members an individual updating service called PLUS which ensures that subscribers automatically receive the latest editions of standards.

Buying standards

Orders for all BSI, international and foreign standards publications should be addressed to Customer Services. Tel: 020 8996 9001. Fax: 020 8996 7001.

In response to orders for international standards, it is BSI policy to supply the BSI implementation of those that have been published as British Standards, unless otherwise requested.

Information on standards

BSI provides a wide range of information on national, European and international standards through its Library and its Technical Help to Exporters Service. Various BSI electronic information services are also available which give details on all its products and services. Contact the Information Centre. Tel: 020 8996 7111. Fax: 020 8996 7048.

Subscribing members of BSI are kept up to date with standards developments and receive substantial discounts on the purchase price of standards. For details of these and other benefits contact Membership Administration. Tel: 020 8996 7002. Fax: 020 8996 7001.

Copyright

Copyright subsists in all BSI publications. BSI also holds the copyright, in the UK, of the publications of the international standardization bodies. Except as permitted under the Copyright, Designs and Patents Act 1988 no extract may be reproduced, stored in a retrieval system or transmitted in any form or by any means – electronic, photocopying, recording or otherwise – without prior written permission from BSI.

This does not preclude the free use, in the course of implementing the standard, of necessary details such as symbols, and size, type or grade designations. If these details are to be used for any other purpose than implementation then the prior written permission of BSI must be obtained.

If permission is granted, the terms may include royalty payments or a licensing agreement. Details and advice can be obtained from the Copyright Manager. Tel: 020 8996 7070.