

BS 7291-1:2010



BSI Standards Publication

Thermoplastics pipe and fitting systems for hot and cold water for domestic purposes and heating installations in buildings

Part 1: General requirements

bsi.

...making excellence a habit.™

Publishing and copyright information

The BSI copyright notice displayed in this document indicates when the document was last issued.

© BSI 2010

ISBN 978 0 580 68861 4

ICS 83.140.30, 91.140.60

The following BSI references relate to the work on this standard:

Committee reference PRI/88

Draft for comment 09/30208674 DC

Publication history

First published May 1990

Second edition, October 2001

Third edition, June 2006

Fourth (present) edition, April 2010

Amendments issued since publication

Date	Text affected
-------------	----------------------

Contents

Foreword *iii*

1	Scope	1
2	Normative references	1
3	Terms and definitions	2
4	Service conditions	3
5	Dimensions	4
6	Performance	5
7	Intermediate layers of multilayer pipes	7
8	Marking and associated information	7

Annexes

Annex A (normative)	Test for minimum failure time	9
Annex B (normative)	Method of test for hydrostatic pressure resistance of assembled pipes and fittings	13
Annex C (normative)	Method of test for resistance to thermal cycling	14
Annex D (normative)	Method of test for resistance to cyclic pressure shock	18
Annex E (informative)	Guidance on factory control procedures	19

Bibliography 21

List of figures

Figure 1	– Designation of fittings	8
Figure B.1	– Typical arrangement for hydrostatic pressure resistance test for fittings	14
Figure C.1	– Test assembly for systems based on rigid pipes	15
Figure C.2	– Test assembly for systems based on flexible pipes	17
Figure C.3	– Configuration of bent flexible pipes for thermal cycle testing	18
Figure D.1	– Diagram of typical equipment arrangement for cyclic pressure shock test	19

List of tables

Table 1	– Class "S" service conditions	4
Table 2	– Circumferential stress values	5
Table 3	– Conditions constituting a change of material	7
Table A.1	– Failure point distribution	9
Table A.2	– Percentage points of Student's <i>t</i> distribution (upper 2.5 % points)	12
Table C.1	– Thermal cycling test schedule	15
Table E.1	– Applicability of requirements and test methods	20

Summary of pages

This document comprises a front cover, an inside front cover, pages i to iv, pages 1 to 22, an inside back cover and a back cover.

Foreword

Publishing information

This part of BS 7291 is published by BSI and came into effect on 30 April 2010. It was prepared by Subcommittee PRI/88/2/P3, *Plastics piping for hot and cold water*, under the authority of Technical Committee PRI/88, *Plastics piping systems*. A list of organizations represented on this committee can be obtained on request to its secretary.

Supersession

BS 7291-1:2010 supersedes BS 7291-1:2006, which is withdrawn.

Information about this document

The increase in unvented hot water storage systems in the UK, and the higher temperatures and pressures associated with these, lead to potential health and safety concerns in the UK. These are addressed by the exclusive use of the Class "S" for the full range of service conditions given in Table 1.

The size range of pipes and associated fittings to which this standard is applicable is up to and including 110 mm nominal outside diameter. Particular ranges of sizes are specified with reference to BS ISO 4065 and/or BS EN 1057 and/or BS EN 1254-2 and/or BS EN 1254-3, as appropriate, by the other parts of BS 7291. These alternative size ranges arise because, in addition to providing for specifications in accordance with metric sizes of thermoplastics pipes, it is considered desirable to standardize the requirements for plastics pipes made and widely used for such applications with dimensions compatible with pipework, fittings and accessories for metric sizes of copper pipes.

Additional requirements for pipes and fittings made from specific types of thermoplastics materials are specified in other parts of BS 7291:

Part 2: *Specification for polybutylene (PB) pipes and associated fittings;*

Part 3: *Specification for cross-linked polyethylene (PE-X) pipes and associated fittings.*

In particular, these parts specify requirements and test methods to ensure the quality of the material and the performance of pipes and fittings of that material, including requirements for component dimensions, which contribute to performance. The other parts also rationalize the pipe sizes specified and identify suitable jointing methods.

Fittings are permitted to be made of plastics materials other than those from which the pipes are made or of other materials, e.g. metallic fittings conforming to BS EN 1254-2 and/or BS EN 1254-3, subject to conformity with this part of BS 7291 and with any applicable requirements for jointed assemblies specified in BS 7291-2 or BS 7291-3, as applicable.

Attention is drawn to BS 5955-8, which specifies the installation requirements for plastics pipes and associated fittings falling within the scope of BS 7291 and references other relevant standards.

Presentational conventions

The provisions of this standard are presented in roman (i.e. upright) type. Requirements are expressed in sentences in which the principal auxiliary verb is "shall".

Where optional recommendations are included, they are expressed in sentences in which the principal auxiliary verb is "should".

Commentary, explanation and general informative material is presented in smaller italic type, and does not constitute a normative element.

Product certification/inspection/testing. Users of this British Standard are advised to consider the desirability of third-party certification/inspection/testing of product conformity with this British Standard. Appropriate conformity attestation arrangements are described in BS EN ISO/IEC 17025. Users seeking assistance in identifying appropriate conformity assessment bodies or schemes may ask BSI to forward their enquiries to the relevant association.

Assessed capability. Users of this British Standard are advised to consider the desirability of quality system assessment and registration against the appropriate standard in the BS EN ISO 9000 series by an accredited third-party certification body.

Contractual and legal considerations

This publication does not purport to include all the necessary provisions of a contract. Users are responsible for its correct application.

Compliance with a British Standard cannot confer immunity from legal obligations.

In particular, attention is drawn to the following statutory regulations:

The Health and Safety at Work, etc Act 1974 [1]

The Water Supply (Water Fittings) Regulations 1999 [2]

Annex A, Annex B, Annex C and Annex D are normative. Annex E is informative.

1 Scope

This part of BS 7291 specifies general requirements and methods of test for thermoplastics pipe and fitting systems intended for use within buildings for the conveyance of cold water, including drinking water, and heated water for use in domestic hot and cold water distribution and heating installations. These systems are also suitable for the conveyance of cold water for a period of 50 years at a temperature of 20 °C and a design pressure of 12½ bar.

This British Standard is applicable only to Class "S" pipes and fittings. Details of the specific applications and service conditions are given in Table 1.

This specification is applicable to rigid or flexible plain pipes, pipes incorporating a polymeric barrier to inhibit gas permeability through the pipe wall and multilayer pipes having a nominal outside diameter up to and including 110 mm.

NOTE 1 Methods of test are given in Annex A, Annex B, Annex C and Annex D. Annex E gives guidance on factory control procedures.

NOTE 2 BS 7291-2 and BS 7291-3 specify additional requirements for pipes and/or fittings manufactured from specific thermoplastics materials. They should be read in conjunction with this part of BS 7291.

NOTE 3 Reference to "pressure" in this part of BS 7291 means "gauge pressure", unless otherwise stated.

NOTE 4 Where the pipe or fitting is of a thermoplastics material covered by BS 7291-1, BS 7291-2 or BS 7291-3, either the requirements for preventing or controlling the extent of permeation specified in the applicable part, e.g. by use of a barrier pipe, should be followed, or a corrosion inhibitor added to the primary circuits in accordance with BS 5955-8.

2 Normative references

The following referenced documents are indispensable for the application of this document. For dated references, only the edition cited applies. For undated references, the latest edition of the referenced document (including any amendments) applies.

BS 5955-8, *Plastics pipework (thermoplastics materials) – Part 8: Specification for the installation of thermoplastics pipes and associated fittings for use in domestic hot and cold water services and heating systems in buildings*

BS 6100-5, *Building and civil engineering – Vocabulary – Part 5: Civil engineering – Water engineering, environmental engineering and pipe lines*

BS 6100-7, *Building and civil engineering – Vocabulary – Part 7: Services*

BS 6920-1, *Suitability of non-metallic products for use in contact with water intended for human consumption with regard to their effect on the quality of the water – Part 1: Specification*

BS 7291-2:2010, *Thermoplastics pipe and fitting systems for hot and cold water for domestic purposes and heating installations in buildings – Part 2: Specification for polybutylene (PB) pipe and associated fittings*

BS 7291-3:2010, *Thermoplastics pipe and fitting systems for hot and cold water for domestic purposes and heating installations in buildings – Part 3: Specification for cross-linked polyethylene (PE-X) pipes and associated fittings*

BS EN 578, *Plastics piping systems – Plastics pipes and fittings – Determination of the opacity*

BS EN 1057, *Copper and copper alloys – Seamless, round copper tubes for water and gas in sanitary and heating installations*

BS EN 1254-2, *Copper and copper alloys – Plumbing fittings – Part 2: Fittings with compression ends for use with copper tubes*

BS EN 1254-3, *Copper and copper alloys – Plumbing fittings – Part 3: Fittings with compression ends for use with plastics pipes*

BS EN ISO 15875-2:2003, *Plastics piping systems for hot and cold water installations – Crosslinked polyethylene (PE-X) – Part 2: Pipes*

BS EN ISO 15876-2:2003, *Plastics piping systems for hot and cold water installations – Polybutylene (PB) – Part 2: Pipes*

BS EN ISO 1167-1, *Thermoplastics pipes, fittings and assemblies for the conveyance of fluids – Determination of the resistance to internal pressure – Part 1: General methods*

BS EN ISO 1167-2, *Thermoplastics pipes, fittings and assemblies for the conveyance of fluids – Determination of the resistance to internal pressure – Part 2: Preparation of pipe test pieces*

BS EN ISO 7686, *Plastics pipes and fittings – Determination of opacity*

BS EN ISO 3126, *Plastics piping systems – Plastics components – Determination of dimensions*

BS ISO 17455, *Plastics piping systems – Multilayer pipes – Determination of the oxygen permeability of the barrier pipe*

BS ISO 472, *Plastics – Vocabulary*

BS ISO 4065, *Thermoplastics pipes – Universal wall thickness table*

3 Terms and definitions

For the purposes of this British Standard, the terms and definitions given in BS ISO 472, BS 6100-5, BS 6100-7 and the following apply.

3.1 flexible pipes

pipes available in coil form

3.2 rigid pipes

pipes available only in straight lengths

3.3 oxygen barrier pipes

pipes incorporating a polymeric barrier layer to prevent or greatly diminish the diffusion of oxygen into or through the pipe wall where the design stress requirements are entirely met by base polymer

NOTE The performance requirements, with the exception of oxygen permeability, are the same for plain pipes, barrier pipes and multilayer pipes.

3.4 maximum system service temperature T_s

maximum service temperature that can occur during normal operation

NOTE An example is thermal stratification within hot water storage vessels or of the positioning and/or operating tolerances of temperature controls.

3.5 nominal system flow temperature T_f

intended maximum flow temperature of a system for a particular application as recommended in codes of practice and other guidance documents

3.6 system malfunction temperature T_m

maximum temperature likely to be applied to pipes and fittings in the event of control thermostat failure or malfunction

3.7 multilayer pipes

pipes comprising layers of polymer materials

NOTE Layers may consist of polybutylene (PB) or cross-linked polyethylene (PE-X) layers, adhesive and intermediate layers (see also Clause 7). Layers may have the ability to:

- a) withstand pressure;
- b) block or greatly reduce the permeation of oxygen or other substances into the pipe;
- c) create interlayer adhesion;
- d) block or greatly reduce incoming UV and/or sunlight;
- e) mechanically protect other layers;
- f) control the longitudinal expansion;
- g) give the multilayer pipe a colour.

Some characteristics can be combined in one layer.

4 Service conditions

Pipes and fittings shall be capable of performing to all the application criteria of Table 1 without exception.

Table 1 Class "S" service conditions

Application	Nominal system flow temperature T_f °C	Maximum system service temperature T_s °C	System malfunction temperature T_m °C	System maximum working pressure ^{A)} bar ^{B)}
Indirect cold water systems	20	20	—	3½
Direct mains-fed cold water systems	20	20	—	12½
Subsurface heating systems	60	83	100	3½
Vented hot water supply systems	65	83	100	3½
Unvented hot water supply systems including instantaneous heaters and/or incorporating storage	65	95	100	6
Vented central heating systems and indirect hot water primary circuits	82	95	100	3½
Sealed central heating systems and indirect hot water primary circuits	82	105	114	3

Continuously operated re-circulating systems are excluded from these applications

A) Where a nominal working pressure does not comprise an integer value, the mantissa is expressed in a fractional format. This is done to reduce the possibility of misinterpretation or obscurity that could cause a system to be subjected to an excessive pressure (see also 8.4).

B) 1 bar = 10^5 N/m² = 10^5 Pa.

5 Dimensions

5.1 General

Subject to 5.2 and 5.3, the dimensions and their tolerances for specific pipes shall be as specified in BS 7291-2 and BS 7291-3, as applicable, and shall be compatible with either:

- outside diameters up to and including 110 mm for pipe systems conforming to BS ISO 4065; or
- compression fittings conforming to BS EN 1254-2 and/or BS EN 1254-3 to suit sizes of tube up to and including 35 mm conforming to BS EN 1057.

NOTE 1 The sizes adopted for a specific component may be selected from either or both of the ranges in a) and b).

NOTE 2 The dimensions and associated tolerances for fittings to suit a given pipe and application are not specified but are controlled by the need for conformity with the performance requirements of BS 7291-1 and BS 7291-2 and BS 7291-3, as applicable. The method of designating the size or pattern of a fitting is specified in 8.5.

5.2 Wall thickness of pipes

When determined in accordance with BS EN ISO 3126, the wall thickness of pipe shall be not less than one eleventh of the outside diameter, subject to a minimum value of 1.5 mm.

5.3 Coatings

If pipe is coated, the coating shall be sufficiently thin and/or removable to enable jointing with fittings and materials specified in BS 7291-2:2010, 5.1, or BS 7291-3:2010, 5.1, as applicable.

NOTE Attention is drawn to 6.1; consideration should be given to the possibility of diffusion of external coating constituents through the wall of the pipe to its interior.

6 Performance

6.1 Effect of materials on the quality of drinking water

Non-metallic products in contact or likely to come into contact with drinking water shall conform to BS 6920-1.

NOTE There is no corresponding British Standard or associated test methods generally applicable to metallic products which might come into contact with drinking water. Attention is drawn to the Water Supply (Water Fittings) Regulations [2] and to BS EN 1254-2 and/or BS EN 1254-3.

6.2 Long-term hydrostatic strength of pipes

6.2.1 Pipes shall either:

- a) conform to 6.2.2; or
- b) be tested in accordance with, and conform to, BS EN ISO 15875-2:2003, 4.2 (PE-X), or BS EN ISO 15876-2:2003, 4.2 (PB), as applicable.

6.2.2 When pipes are tested in accordance with Annex A:

- a) there shall be no rupturing or cracking throughout the wall thickness of the test piece at any point, or leakage at any associated joint under test; and
- b) the extrapolated failure times at the circumferential stress values given in Table 2 shall be not less than 438 000 h (50 years); and
- c) the 97.5% lower confidence limits of the failure times at those stress values shall be not less than 100 000 h.

Table 2 Circumferential stress values

Temperature	Stress
°C	MPa
20	9.0
65	4.5
100	2.6

6.3 Hydrostatic pressure resistance of assembled pipes and fittings

When fittings are tested in accordance with Annex B, there shall be no rupturing or cracking throughout the wall thickness of the test piece at any point, or leakage at any associated joint under test, and:

- a) the time to failure at 20 °C and 20 bar pressure shall be not less than 1 000 h;
- b) the time to failure at 95 °C and 10 bar pressure shall be not less than 1 000 h.

6.4 Resistance to thermal cycling of assembled pipes and fittings

When tested in accordance with Annex C, there shall be no leakage from pipes, fittings or joints during or at the end of testing.

NOTE The test in Annex C may be used to confirm compatibility of thermoplastics pipes and fittings with copper pipes and compression fittings conforming to BS EN 1057 and/or BS EN 1254-2 and/or BS EN 1254-3.

In this case, the test is performed with copper pipes and thermoplastics fittings using the assembly shown in Figure C.1 and with thermoplastics pipes and compression fittings using the assembly shown in Figure C.2

This is not a requirement of BS 7291:2010 and is included as an optional procedure to provide evidence of compliance with the regulators' specification for water fittings requirements.

6.5 Resistance to cyclic pressure shock of assembled pipes and fittings

When tested in accordance with Annex D, there shall be no leakage from pipes, fittings or joints.

6.6 Opacity

When determined in accordance with BS EN ISO 7686, the percentage of light passing through the wall of the pipe or fitting shall not exceed 0.2%. In the case of pipe supplied in a protective sleeve, this requirement shall relate to the performance of the combination of both pipe and sleeve.

To ensure conformity, the combination of pipe and sleeve shall not depend upon subsequent assembly of pipe and sleeve.

6.7 Oxygen permeability of multilayer oxygen barrier pipes

When multilayer oxygen barrier pipes are tested in accordance with BS ISO 17455:2005, Method I, at a temperature of 80 °C and with four connecting fittings of the system under test, the oxygen permeability shall be $\leq 3.6 \text{ mg/m}^2 \cdot \text{day}$.

6.8 Conditions constituting a change of material

If any of the characteristics in Table 3 are changed, or any level exceeds the band, the product shall be retested in accordance with this part of BS 7291 and BS 7291-2 (polybutylene) or BS 7291-3 (cross-linked polyethylene), as applicable.

Table 3 Conditions constituting a change of material

Type of material change	Characteristics, value X and band
Change of polymer	Change of supplier
	Change of polymerization
	Change of chemical properties of comonomers
Change of additive package (e.g. pigments, antioxidants)	Amount greater than $X \pm 30\%$ of individual additive;
	Chemical properties or nature of additive

7 Intermediate layers of multilayer pipes

Any intermediate layers shall include only layers made of polymers; no metal layers shall be used.

8 Marking and associated information

8.1 Each pipe shall be marked in accordance with BS 7291-2:2010, 6.1, or BS 7291-3:2010, 6.1, as applicable.

8.2 Each fitting shall be marked in accordance with BS 7291-2:2010, 6.2, or BS 7291-3:2010, 6.2.

8.3 The marking specified in BS 7291-2:2010, Clause 6, and BS 7291-3:2010, Clause 6, shall contrast clearly with the colour of the pipe, fitting or label, as applicable. It shall remain legible under handling, storage and installation conditions in accordance with BS 5955-8. Marking by indentation shall be to a depth not greater than 0.15 mm. There shall be no spaces greater than 0.5 m in length between each block of text.

8.4 If additional markings include a pressure rating that does not comprise an integer value, the mantissa shall be presented as a fraction, e.g. $3\frac{1}{2}$ (see Table 1).

8.5 The nominal size of a fitting or of each individual socket thereon shall be designated by the nominal size of the pipe(s) with which it is to be used. The method of designating the fitting shall be as follows, depending on the type of fitting.

- a) *Straight fittings and bends.* For fittings having two unequal ends, the larger end shall be given first, e.g. 20 × 16.
- b) *Tee fittings.* Tee fittings shall be designated first by the ends on the run, i.e. two ends in the same straight line with, where applicable, the larger of the two being specified first, followed by the other end. (See Figure 1.)
- c) *Transition fittings.* The end relating to BS 7291-1 shall be given first, followed by the other end.

EXAMPLES

22 mm × $\frac{3}{4}$ BSP thread external

10 mm × $\frac{1}{2}$ BSP tail pipe end

22 mm × $\frac{3}{4}$ tank connector

15 mm × $\frac{1}{2}$ tap connector

Figure 1 Designation of fittings

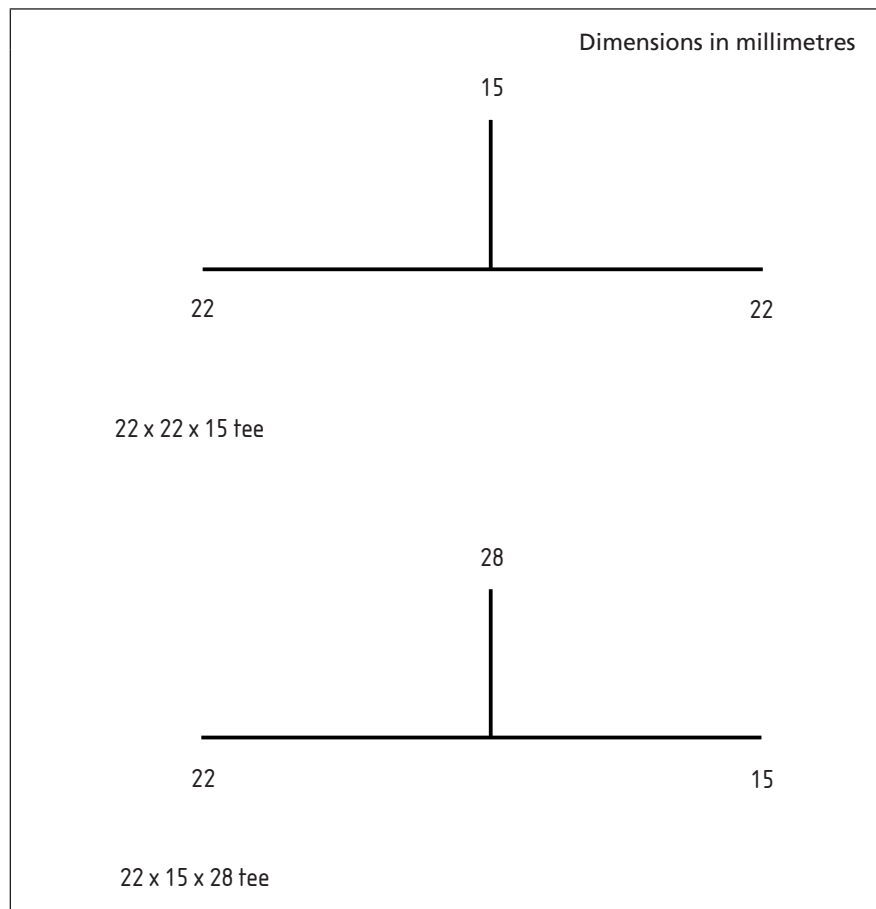

Annex A (normative) Test for minimum failure time

A.1 Principle

This method determines the minimum failure time of a thermoplastics material to be used for pipes or fittings class conforming to this standard. Test pieces are in the form of pipe or an assembly of pipes and fittings at the relevant temperatures, or interpolated, from testing, at temperatures above and below those quoted in Table A.2. The test pieces are subjected to levels of sustained hydrostatic stress to produce failures of the pipe alone after periods according to Table A.1. The data are extrapolated to determine the failure times at the relevant stresses and temperatures, with reference to a lower 97.5% confidence limits for the results.

A.2 Apparatus and test temperature

The apparatus shall conform to BS EN ISO 1167-1 and BS EN ISO 1167-2, with water or air for the external test environment. The test temperatures shall be either those given in Table 2, in which case the failure time at the required stress shall be calculated by the method given in A.5, or other test temperatures, provided they are suitable for interpolation of the results in accordance with A.6.

A.3 Test pieces

Each test piece shall be a pipe manufactured from the thermoplastics material to be tested in barrier, non-barrier, or multilayer form. It shall have an outside diameter of 22 mm or the nearest to that diameter in a manufacturer's range of products. The test piece shall be closed with pressure-tight caps or plugs such that the free length between end caps or plugs shall be not less than 150 mm.

A.4 Procedure

Obtain at least 18 test results at each test temperature for the calculation of the log of time versus log of stress regression line specified in A.5, with a failure data point distribution in accordance with Table A.1. Include as failures at the time of testing those test pieces that have not failed after being under test for more than 10 000 h if they increase the value of the extrapolated failure time [see 6.2.2b)].

Table A.1 Failure point distribution

Failure time range h	Minimum data point distribution	Recommended data point distribution ^{A)}
> 10 and < 50	2	≥ 4
≥ 50 and < 2 500	3	≥ 5
≥ 2 500 and < 6 500	3	≥ 4
≥ 6 500 and < 10 000	2	≥ 4
≥ 10 000	1	≥ 1
Total	11 + 7 others	≥ 18

^{A)} While 18 data points, distributed as shown in column 2, is the minimum pattern required, it is recommended that sufficient data points be obtained.

A.5 Method of calculation of the regression line of log time on log stress

A.5.1 The following symbols are used:

n is the number of observations;

f_i is the log of stress (in megapascals) of observation i , $i = 1, \dots, n$;

h_i is the log of time (in hours) of observation i ; $i = 1, \dots, n$;

\bar{f} is the arithmetic mean of all f_i values:

$$\frac{1}{n} \sum_{i=1}^n f_i \quad (\text{A.1})$$

\bar{h} is the arithmetic mean of all h_i values:

$$\frac{1}{n} \sum_{i=1}^n h_i \quad (\text{A.2})$$

The regression equation of log time (h) on log stress (f) is:

$$h = a + bf \quad (\text{A.3})$$

A.5.2 Calculate the following three quantities.

$$S_{ff} = \sum_{i=1}^n f_i^2 - n(\bar{f})^2 \quad (\text{A.4})$$

$$S_{hh} = \sum_{i=1}^n h_i^2 - n(\bar{h})^2 \quad (\text{A.5})$$

$$S_{fh} = \sum_{i=1}^n f_i h_i - n\bar{f}\bar{h} \quad (\text{A.6})$$

A.5.3 Calculate b and a using equations (A.7) and (A.8).

$$b = \frac{S_{fh}}{S_{ff}} \quad (\text{A.7})$$

$$a = \bar{h} - b\bar{f} \quad (\text{A.8})$$

If the slope of the regression line, b , is not negative, reject the results.

A.5.4 Calculate the mean failure time (in hours) at each required stress, using equation (A.3), where:

f is the log of the stress (in megapascals) given in Table 2 for a given test temperature;

antilog h is the failure time (in hours) at a given stress and test temperature.

A.5.5 Calculate the lower 97.5% confidence limit of the mean failure time at each required stress as follows.

Determine the residual variance about the regression line, S_r^2 , from the following equation:

$$S_r^2 = \frac{1}{n-2} \left(S_{hh} - \frac{S_{fh}^2}{S_{ff}} \right) \quad (\text{A.9})$$

Calculate the lower 97.5% confidence limit for one future observation at each stress from the following equation:

$$h_0 = a + bf_0 - t_v S_r \left[1 + \frac{1}{n} + \frac{(f_0 - \bar{f})^2}{S_{ff}} \right]^{0.5} \quad (\text{A.10})$$

where:

- h_0 is the 97.5% lower confidence limit of the estimated log time before failure (in hours) at a given stress and test temperature;
- f_0 is the log of the stress (in megapascals) given in Table 2 for test temperature;
- t_v is the Student's t for $v = n - 2$ degrees of freedom, as given in Table A.2, which gives the upper 2.5% points.

A.6 Interpolation

If testing has been carried out at temperatures other than those given in Table 2, providing data at two temperatures, one above (T_1) and one below (T_2) the temperature (T_f) specified, use the following method of interpolation to estimate failure times at a given temperature.

Following the procedure in A.4 and A.5, calculate the values of h at each temperature, $h_{(T_1)}$ and $h_{(T_2)}$, for the specified stress value.

Calculate the estimated value of $h_{(T_f)}$ for the specified temperature and stress value using the following equation:

$$h_{(T_f)} = h_{(T_1)} + \frac{(h_{(T_2)} - h_{(T_1)})(T_1 - T_f)}{(T_1 - T_2)} \quad (\text{A.11})$$

Use the same method for the calculation of interpolated values of the lower 97.5% confidence limit of the estimated time before failure (h_0) at a given stress and test temperature.

A.7 Test report

The test report shall include the following:

- a) identification of the test specimens;
- b) a reference to this method of test, i.e. BS 7291-1:2010, Annex A;
- c) the test temperature;
- d) the estimated failure time and lower 97.5% confidence limit of failure time (in hours) at a given test temperature and stress at this value;
- e) the interpolated values for failure times and lower 97.5% confidence limits at the stress values and temperatures required for conformity to Table 2;
- f) the date of the test, e.g. the month(s) and year(s) during which the pressure testing was conducted.

Table A.2 Percentage points of Student's *t* distribution (upper 2.5 % points)

<i>v</i>	<i>t_v</i>	<i>v</i>	<i>t_v</i>	<i>v</i>	<i>t_v</i>
1	12.7062	46	2.0129	91	1.9864
2	4.3027	47	2.0117	92	1.9861
3	3.1824	48	2.0106	93	1.9858
4	2.7764	49	2.0096	94	1.9855
5	2.5706	50	2.0086	95	1.9853
6	2.4469	51	2.0076	96	1.9850
7	2.3646	52	2.0066	97	1.9847
8	2.3060	53	2.0057	98	1.9845
9	2.2622	54	2.0049	99	1.9842
10	2.2281	55	2.0040	100	1.9840
11	2.2010	56	2.0032	102	1.9835
12	2.1788	57	2.0025	104	1.9830
13	2.1604	58	2.0017	106	1.9826
14	2.1448	59	2.0010	108	1.9822
15	2.1315	60	2.0003	110	1.9818
16	2.1199	61	1.9996	112	1.9814
17	2.1098	62	1.9990	114	1.9810
18	2.1009	63	1.9983	116	1.9806
19	2.0930	64	1.9977	118	1.9803
20	2.0860	65	1.9971	120	1.9799
21	2.0796	66	1.9966	122	1.9796
22	2.0739	67	1.9960	124	1.9793
23	2.0687	68	1.9955	126	1.9790
24	2.0639	69	1.9949	128	1.9787
25	2.0595	70	1.9944	130	1.9784
26	2.0555	71	1.9939	132	1.9781
27	2.0518	72	1.9935	134	1.9778
28	2.0484	73	1.9930	136	1.9776
29	2.0452	74	1.9925	138	1.9773
30	2.0423	75	1.9921	140	1.9771
31	2.0395	76	1.9917	142	1.9768
32	2.0369	77	1.9913	144	1.9766
33	2.0345	78	1.9908	146	1.9763
34	2.0322	79	1.9905	148	1.9761
35	2.0301	80	1.9901	150	1.9759
36	2.0281	81	1.9897	200	1.9719
37	2.0262	82	1.9893	300	1.9679
38	2.0244	83	1.9890	400	1.9659
39	2.0227	84	1.9886	500	1.9647
40	2.0211	85	1.9883	600	1.9639
41	2.0195	86	1.9879	700	1.9634
42	2.0181	87	1.9876	800	1.9629
43	2.0167	88	1.9873	900	1.9626
44	2.0154	89	1.9870	1000	1.9623
45	2.0141	90	1.9867	∞	1.9600

Annex B (normative) **Method of test for hydrostatic pressure resistance of assembled pipes and fittings**

B.1 Principle

An assembly incorporating one or more fittings jointed with pipe is subjected to a sustained pressure at a specified temperature, and inspected for rupture or leakage before a specified period of time has elapsed.

B.2 Apparatus

The apparatus shall conform to BS EN ISO 1167-1 and BS EN ISO 1167-2, with water or air as the external test environment, together with ancillary supports as necessary to accommodate a test assembly conforming to B.3.

B.3 Test assembly

The test assembly shall comprise an assembly of at least one fitting having at least one connection jointed and clipped in accordance with the manufacturer's recommended practice to the corresponding PB (BS 7291-2) or PE-X pipe (BS 7291-3) and, if required, copper pipe. This pipe may be connected in turn with other fittings comprising either other test pieces or fittings in the form of terminal fittings or pressure-tight connections in accordance with BS EN ISO 1167-2, e.g. as shown in Figure B.1.

B.4 Procedure

Prepare the test assembly for testing and prime it with water so that all air is excluded. Bring the test piece and its contents to the temperature specified in 6.3a) or 6.3b), as applicable. Condition and pressurize them in accordance with BS EN ISO 1167-1 to establish the applicable test conditions. Maintain the test conditions until the fitting, pipe or any associated joint under test fails or until the minimum required period under test has been exceeded.

B.5 Test report

The test report shall include the following:

- a) identification of the component(s) under test;
- b) a reference to this method of test, i.e. BS 7291-1:2010, Annex B;
- c) the test temperature and test pressure;
- d) any observations of rupturing or signs of leakage;
- e) the dates between which the testing under pressure was conducted and the period (in hours) for which no failure was apparent.

Figure B.1 Typical arrangement for hydrostatic pressure resistance test for fittings

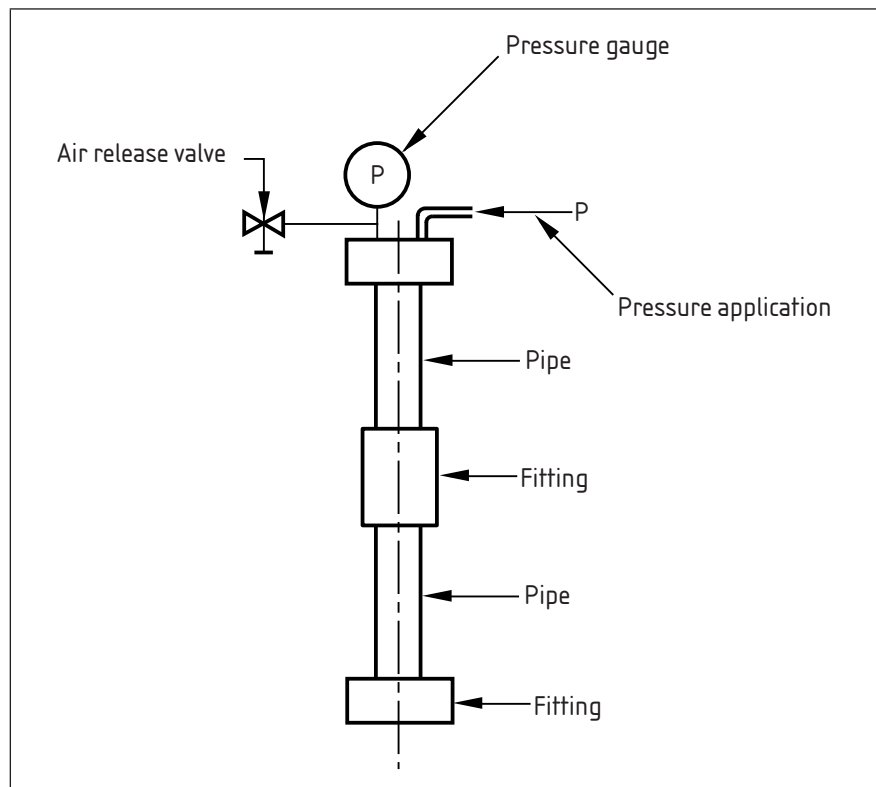

Annex C (normative) Method of test for resistance to thermal cycling

C.1 Principle

An assembly of pipe and fittings is subjected to thermal cycling by the passage of water, followed by a brief test at elevated pressure, then inspected for leakage.

C.2 Apparatus

The apparatus shall comprise means of:

- alternately circulating hot and cold water through the test assembly in accordance with the schedules given in Table C.1;
- regulating the water pressure in the test assembly; and
- measuring the water temperature at the inlet to and outlet from the test assembly.

The alternation equipment shall be capable of effecting each change between hot and cold water sources within a specified period.

For testing of flexible pipe, devices shall be included to apply a sustained tension to lengths of straight pipe.

Table C.1 Thermal cycling test schedule

Hot water		Cold water		Minimum pressure	Number of cycles
Inlet temperature	Duration	Inlet temperature	Duration		
°C	min	°C	min	bar	
83 ±2	20	15 ±5	10	6	5 000
114 ±2	20	15 ±5	10	3½	1 000
105 ±2	20	15 ±5	10	3½	5 000

C.3 Test assembly

C.3.1 General

The test assembly shall comprise pipe and fittings jointed and clipped in accordance with the manufacturer's instructions.

Where a range of fittings is available, the assembly shall comprise a representative selection of sizes and configurations manufactured or recommended by the manufacturer, arranged so that the sizes under test increase sequentially in the direction of flow, e.g. as shown in Figure C.1.

Figure C.1 Test assembly for systems based on rigid pipes

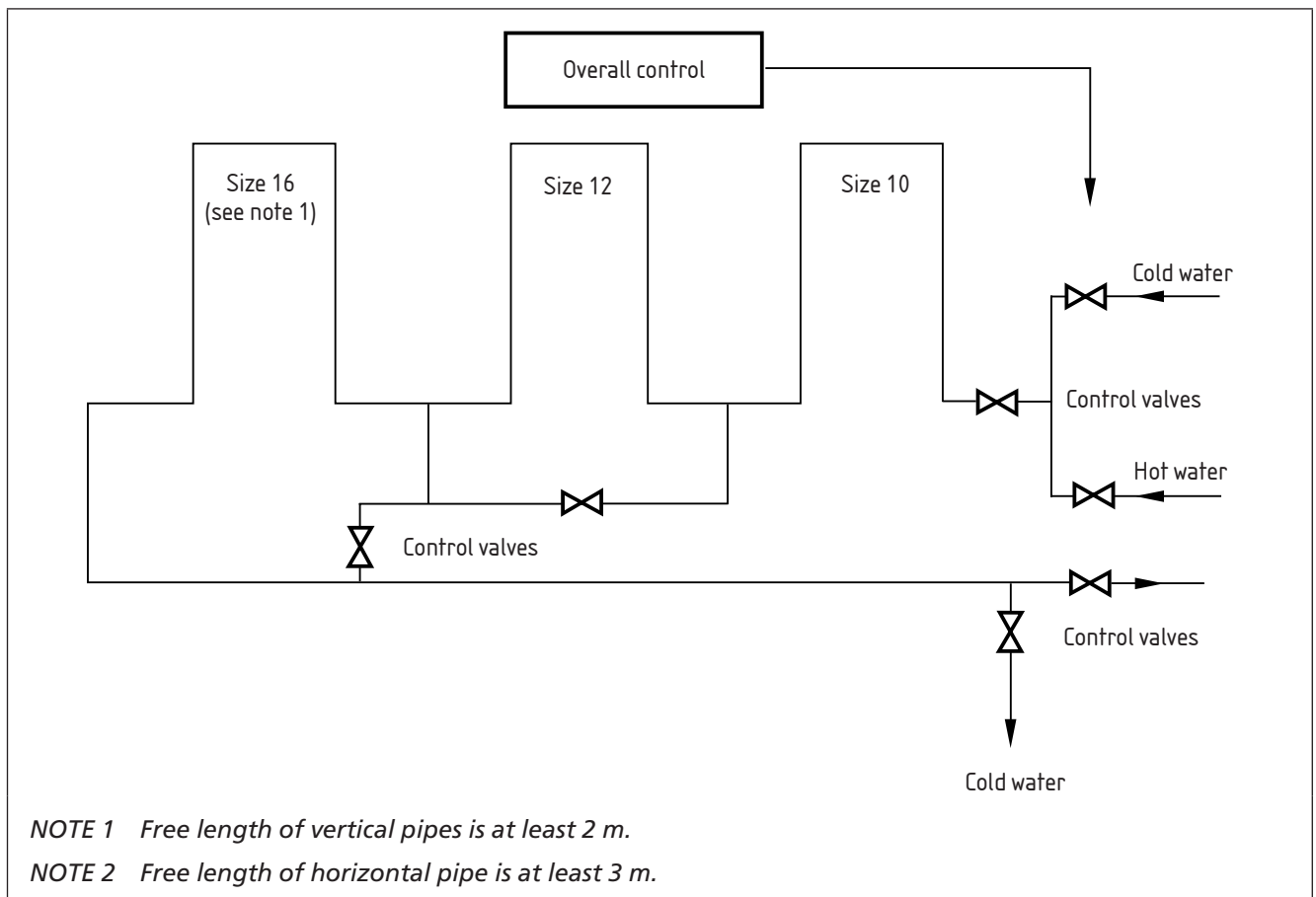

C.3.2 Systems using rigid pipes

The test assembly shall be as shown in Figure C.1, with:

- a) the free length of vertical pipes of at least 2 m;
- b) the free length of horizontal pipes of at least 3 m;
- c) the total number of fittings being no fewer than 20 and including one or more of each of the following types of fittings:
 - 1) straight connector;
 - 2) 90° elbow;
 - 3) 90° tee;
 - 4) plastics to metal transition fitting.

If a manufacturer recommends a particular installation practice, for example an expansion loop, bend clip or cold bend, it shall be included in the test.

C.3.3 Systems using flexible pipes

The test assembly shall include:

- a) at least one pair of pre-stressed pipes linked by a straight connector, incorporated in accordance with Figure C.2 (see Branch A) and stressed in accordance with C.4, with the free length of each such combination being $3\text{ m} \pm 25\text{ mm}$;
- b) at least two straight pipes, each free to move when incorporated as shown in Figure C.2 (see Branch B) and each having a free length of $(300 \pm 5)\text{ mm}$;
- c) at least one bent pipe, as shown in Figure C.3, with each pipe supported only by its ends when incorporated in accordance with Figure C.2, such that the free length of the pipe lies in the range $27d_e$ to $28d_e$, inclusive, where d_e is the nominal outside diameter of the pipe.

C.4 Procedure

Prepare the test assembly for testing and prime it with water so that all air is excluded.

In the case of flexible piping, pre-stress the test pieces (see C.3.3 and Figure C.2) to an initial tensile stress equivalent to that induced by contraction when subjected to a temperature drop of 20 °C.

Subject the test assembly to the passage of the specified cycles of hot and cold water at the pressures, temperatures and durations specified in Table C.1, with each temperature change from hot to cold water and vice versa effected within 1 min. Perform any desired tightening or adjustment of joints within the first five cycles. Control the flow rate of the circulating water such that the measured temperature drop on the hot cycle from the inlet to the outlet of the test assembly does not exceed 5 °C.

On completion of the cyclic test schedule, subject the assembly to an internal pressure of not less than 18 bar at (15 ± 5) °C for not less than 15 min and inspect all joints for signs of leakage.

NOTE To minimize temperature differences, balancing valves or series connections might be necessary in parts of the circuit.

c.5 Test report

The test report shall include the following:

- a) identification of the components under test;
- b) a reference to this method of test; i.e. BS 7291-1:2010; Annex C;
- c) the test conditions, as indicated by Class "S";
- d) any observations of signs of leakage;
- e) the period of the test, e.g. the dates between which the thermal cycling test schedule was conducted.

Figure C.2 Test assembly for systems based on flexible pipes

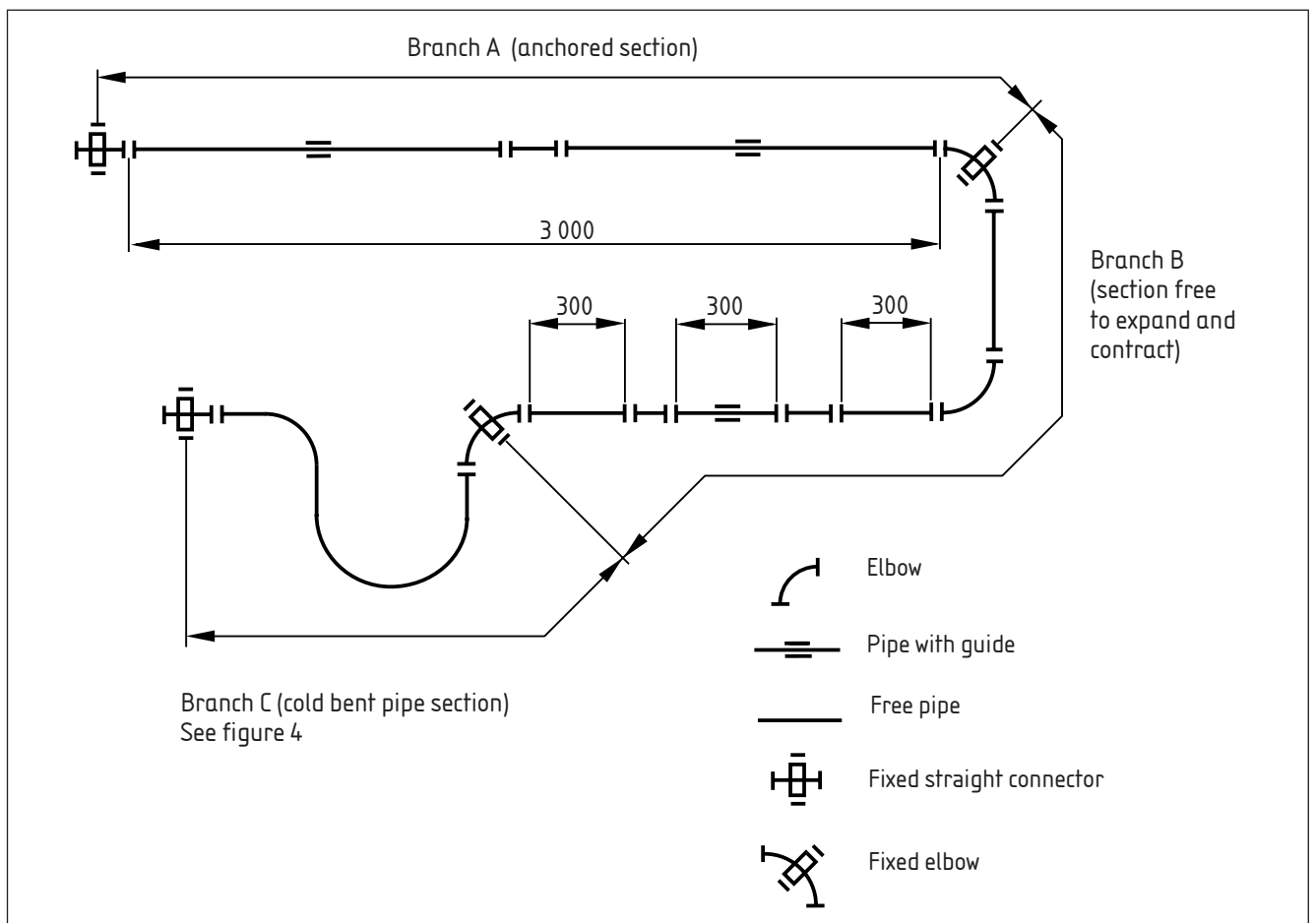
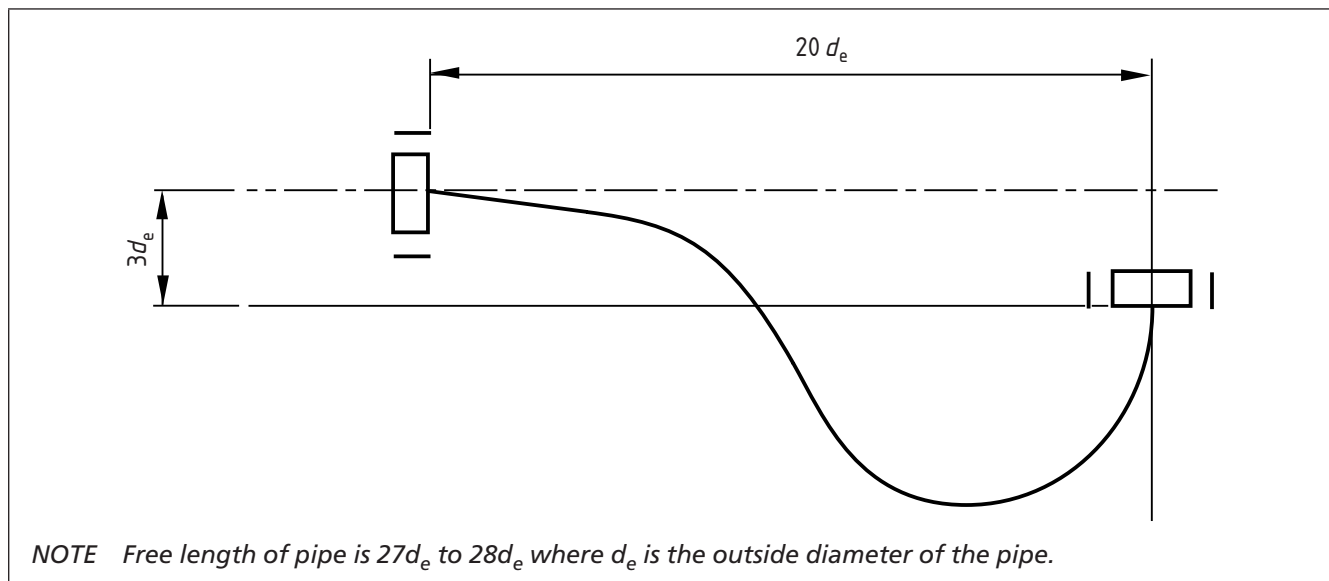

Figure C.3 Configuration of bent flexible pipes for thermal cycle testing



Annex D (normative) Method of test for resistance to cyclic pressure shock

D.1 Principle

An assembly of pipes and/or fittings is subjected to rapid pressure cycling between two positive pressure limits via a liquid medium while being maintained at elevated temperature and inspected for leakage.

D.2 Apparatus

D.2.1 Means for regulating the temperature of the test assembly and water therein, while subjecting the latter to cyclic pressure variations between specified limits at a rate of not less than 30 cycles per minute.

NOTE A typical arrangement is shown in Figure D.1.

D.3 Test assembly

The test assembly shall comprise three samples of each pipe and/or fitting under test, jointed in accordance with the manufacturer's instructions with one or more pieces of pipe, and each at least $10d_n$ in length, where d_n is the nominal outside diameter of the pipe.

NOTE In order to include the required number of pipes and/or fittings, several assemblies may be tested simultaneously.

D.4 Procedure

Prepare the test assembly for testing and prime it with water so that all air is excluded. Bring the test assembly and water therein to (93 ± 2) °C and condition it at that temperature for at least 1 h immediately before applying alternately internal positive pressures of (1 ± 0.5) bar and (9 ± 0.5) bar at a frequency of at least 30 pressure cycles (i.e. 1 bar to 9 bar to 1 bar again) per minute, while continuing to maintain the temperature.

After completing 10 000 cycles, inspect all test components and associated joints for signs of leakage.

NOTE The conditioning may be carried out with the test assembly or assemblies connected to the pressure converter, but not necessarily so. If subsequent connection is necessary, it is important to ensure that all air is again excluded.

D.5 Test report

The test report shall include the following:

- a) identification of the components and joints under test;
- b) a reference to this method of test, i.e. BS 7291-1:2010, Annex D;
- c) any observations of signs of leakage;
- d) the date of the test.

Figure D.1 Diagram of typical equipment arrangement for cyclic pressure shock test

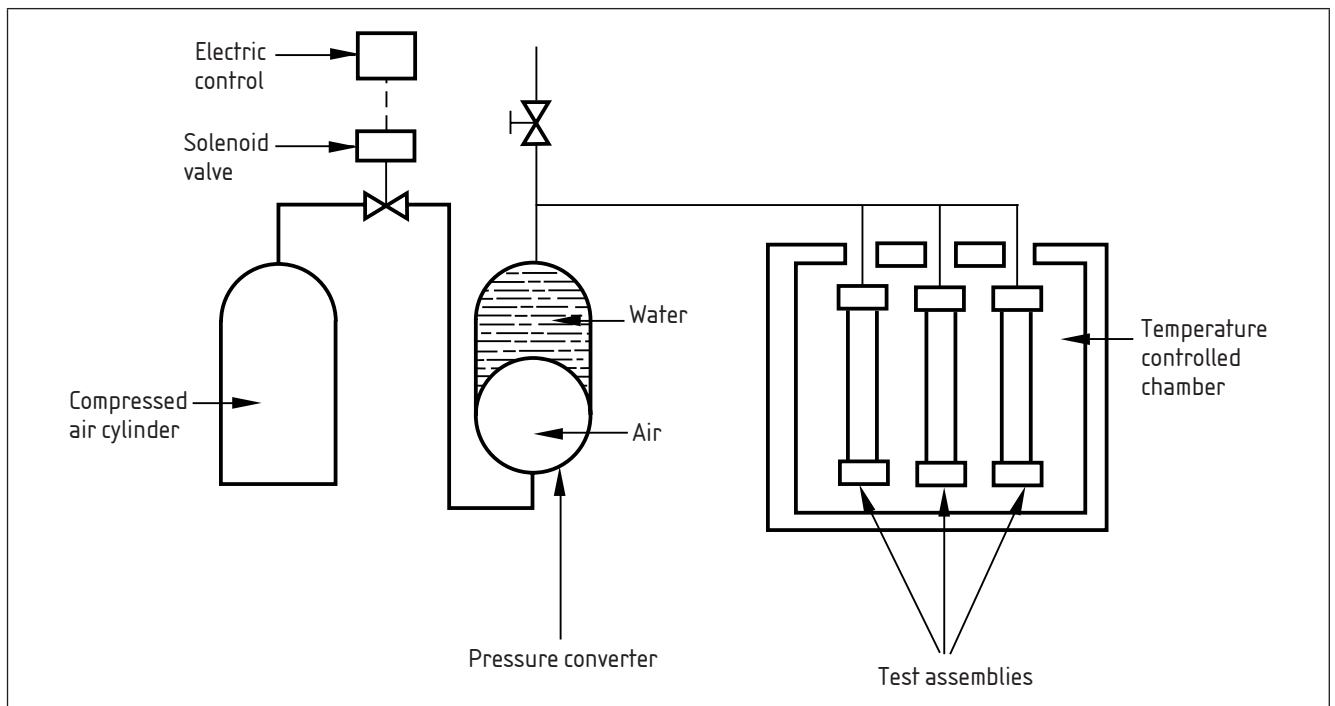

Annex E (informative) Guidance on factory control procedures

The following guidance on the nature of the requirements and test methods specified in this part of BS 7291 is provided to assist in the preparation of quality plans for the manufacture of pipes or fittings conforming to this and other parts of BS 7291.

The applicability of specific requirements and associated methods of test to different types of pipe or fitting is summarized in Table E.1, in which each requirement is classified as being considered particularly suitable for type test and/or batch release test (BRT) purposes.

Type tests are intended to prove the suitability and performance of a material composition, a compounding or processing technique or a design or size of pipe, fitting or joint assembly. Such tests should be performed when any introduction or change is made in one or more

of those aspects, but they may be performed more frequently by incorporation into a plan for monitoring the consistency of manufacture.

Batch release tests are carried out during and/or following manufacture to monitor the quality of a product item, as applicable. Certain test methods and associated requirements have been included because of the practicality and speed with which they can be performed in conjunction with a production process, compared with some of the type tests.

Some of the requirements in this standard are relevant to both type test and BRT purposes, e.g. those for dimensions.

Table E.1 **Applicability of requirements and test methods**

Product	Property	Clause	Method	Test type	
				Type test	BRT
Pipes and fittings	Dimensions	5	BS EN ISO 3126	x	
Pipes and fittings	Effect on the quality of potable water	6.1	BS 6920-1	x	
Pipes	Long-term hydrostatic strength	6.2	BS 7291-1, Annex A	x	
Pipes and fittings	Hydrostatic pressure resistance	6.3	BS 7291-1, Annex B	x	
Pipes and fittings	Resistance to thermal cycling	6.4	BS 7291-1, Annex C	x	
Pipes and fittings	Resistance to cyclic pressure shock	6.5	BS 7291-1, Annex D	x	
Pipes and fittings	Opacity	6.6	BS EN ISO 7686	x	
Pipes	Oxygen permeability	6.7	BS 7291-1, 6.7	x	
Pipes and fittings	Marking and associated information	8		x	x

NOTE All references to BS 7291-1:2010.

Bibliography

Standards publications

For dated references, only the edition cited applies. For undated references, the latest edition of the referenced document (including any amendments) applies.

BS EN ISO/IEC 17025, *General requirements for the competence of testing and calibration laboratories*

BS EN ISO 9000, *Quality management systems*

Other publications

- [1] GREAT BRITAIN: The Health and Safety at Work, etc Act 1974, London: The Stationery Office: London.
- [2] GREAT BRITAIN: The Water Supply (Water Fittings) Regulations 1999, No. 1148, London: The Stationery Office: London.

British Standards Institution (BSI)

BSI is the national body responsible for preparing British Standards and other standards-related publications, information and services.

BSI is incorporated by Royal Charter. British Standards and other standardization products are published by BSI Standards Limited.

About us

We bring together business, industry, government, consumers, innovators and others to shape their combined experience and expertise into standards-based solutions.

The knowledge embodied in our standards has been carefully assembled in a dependable format and refined through our open consultation process. Organizations of all sizes and across all sectors choose standards to help them achieve their goals.

Information on standards

We can provide you with the knowledge that your organization needs to succeed. Find out more about British Standards by visiting our website at bsigroup.com/standards or contacting our Customer Services team or Knowledge Centre.

Buying standards

You can buy and download PDF versions of BSI publications, including British and adopted European and international standards, through our website at bsigroup.com/shop, where hard copies can also be purchased.

If you need international and foreign standards from other Standards Development Organizations, hard copies can be ordered from our Customer Services team.

Subscriptions

Our range of subscription services are designed to make using standards easier for you. For further information on our subscription products go to bsigroup.com/subscriptions.

With **British Standards Online (BSOL)** you'll have instant access to over 55,000 British and adopted European and international standards from your desktop. It's available 24/7 and is refreshed daily so you'll always be up to date.

You can keep in touch with standards developments and receive substantial discounts on the purchase price of standards, both in single copy and subscription format, by becoming a **BSI Subscribing Member**.

PLUS is an updating service exclusive to BSI Subscribing Members. You will automatically receive the latest hard copy of your standards when they're revised or replaced.

To find out more about becoming a BSI Subscribing Member and the benefits of membership, please visit bsigroup.com/shop.

With a **Multi-User Network Licence (MUNL)** you are able to host standards publications on your intranet. Licences can cover as few or as many users as you wish. With updates supplied as soon as they're available, you can be sure your documentation is current. For further information, email bsmusales@bsigroup.com.

BSI Group Headquarters

389 Chiswick High Road London W4 4AL UK

Revisions

Our British Standards and other publications are updated by amendment or revision.

We continually improve the quality of our products and services to benefit your business. If you find an inaccuracy or ambiguity within a British Standard or other BSI publication please inform the Knowledge Centre.

Copyright

All the data, software and documentation set out in all British Standards and other BSI publications are the property of and copyrighted by BSI, or some person or entity that owns copyright in the information used (such as the international standardization bodies) and has formally licensed such information to BSI for commercial publication and use. Except as permitted under the Copyright, Designs and Patents Act 1988 no extract may be reproduced, stored in a retrieval system or transmitted in any form or by any means – electronic, photocopying, recording or otherwise – without prior written permission from BSI. Details and advice can be obtained from the Copyright & Licensing Department.

Useful Contacts:

Customer Services

Tel: +44 845 086 9001

Email (orders): orders@bsigroup.com

Email (enquiries): cservices@bsigroup.com

Subscriptions

Tel: +44 845 086 9001

Email: subscriptions@bsigroup.com

Knowledge Centre

Tel: +44 20 8996 7004

Email: knowledgecentre@bsigroup.com

Copyright & Licensing

Tel: +44 20 8996 7070

Email: copyright@bsigroup.com



...making excellence a habit.™