

# Non-metallic materials for surgical implants —

## Part 6: Specification for ceramic materials based on yttria-stabilized tetragonal zirconia (Y-TZP)

ICS 11.040.40

# National foreword

This British Standard reproduces verbatim ISO 13356:1997 and implements it as the UK national standard.

The UK participation in its preparation was entrusted by Technical Committee CH/18, Surgical implant materials, to Subcommittee CH/18/1, Non-metallic materials, which has the responsibility to:

- aid enquirers to understand the text;
- present to the responsible international/European committee any enquiries on the interpretation, or proposals for change, and keep the UK interests informed;
- monitor related international and European developments and promulgate them in the UK.

A list of organizations represented on this subcommittee can be obtained on request to its secretary.

## Cross-references

The British Standards which implement international or European publications referred to in this document may be found in the BSI Standards Catalogue under the section entitled "International Standards Correspondence Index", or by using the "Find" facility of the BSI Standards Electronic Catalogue.

A British Standard does not purport to include all the necessary provisions of a contract. Users of British Standards are responsible for their correct application.

**Compliance with a British Standard does not of itself confer immunity from legal obligations.**

## Summary of pages

This document comprises a front cover, an inside front cover, pages i and ii, the ISO title page, page ii, pages 1 to 4, an inside back cover and a back cover. This standard has been updated (see copyright date) and may have had amendments incorporated. This will be indicated in the amendment table on the inside front cover.

## Amendments issued since publication

Amd. No.	Date	Comments

This British Standard, having been prepared under the direction of the Health and Environment Sector Board, was published under the authority of the Standards Board and comes into effect on 15 December 1997

© BSI 03-1999

ISBN 0 580 29004 2

---

# Contents

	Page
National foreword	Inside front cover
Foreword	ii
Introduction	1
1 Scope	1
2 Normative references	1
3 Physical and chemical properties	1
4 Test methods	2
Annex A (informative) Bibliography	Inside back cover
Figure 1 — Schematic diagram of the biaxial flexure testing device employing concentric loading and support rings	3
Table 1 — Physical and chemical properties	1



INTERNATIONAL  
STANDARD

**ISO**  
**13356**

First edition  
1997-09-15

---

---

**Implants for surgery — Ceramic materials  
based on yttria-stabilized tetragonal  
zirconia (Y-TZP)**

*Implants chirurgicaux — Produits céramiques à base de zircone  
tétraogonale stabilisée à l'yttrium (Y-TZP)*



Reference number  
ISO 13356:1997(E)

## Foreword

ISO (the International Organization for Standardization) is a worldwide federation of national standards bodies (ISO member bodies). The work of preparing International Standards is normally carried out through ISO technical committees. Each member body interested in a subject for which a technical committee has been established has the right to be represented on that committee. International organizations, governmental and non-governmental, in liaison with ISO, also take part in the work. ISO collaborates closely with the International Electrotechnical Commission (IEC) on all matters of electrotechnical standardization.

Draft International Standards adopted by the technical committees are circulated to the member bodies for voting. Publication as an International Standard requires approval by at least 75 % of the member bodies casting a vote.

International Standard ISO 13356 was prepared by Technical Committee ISO/TC 150, *Implants for surgery*, Subcommittee SC 1, *Materials*.

Annex A of this International Standard is for information only.

**Descriptors:** Medical equipment, special ceramics, surgical implants, specifications, physical properties, chemical properties, radioactivity, tests, determination, chemical composition, microstructure, flexural strength.

## Introduction

No known surgical implant material has ever been shown to cause absolutely no adverse reactions in the human body. However, long-term clinical experience of the use of the material referred to in this International Standard has shown that an acceptable level of biological response can be expected when the material is used in appropriate applications.

## 1 Scope

This International Standard specifies the characteristics of, and corresponding test method for, a biocompatible and biostable ceramic bone-substitute material based on yttria-stabilized tetragonal zirconia (yttria tetragonal zirconia polycrystal, Y-TZP) for use as material for surgical implants.

## 2 Normative references

The following standards contain provisions which, through reference in this text, constitute provisions of this International Standard. At the time of publication, the editions indicated were valid. All standards are subject to revision, and parties to agreements based on this International Standard are encouraged to investigate the possibility of applying the most recent editions of the standards indicated below. Members of IEC and ISO maintain registers of currently valid International Standards.

ISO 3611:1978, *Micrometer callipers for external measurement.*

ISO 5017:—<sup>1)</sup>, *Dense shaped refractory products — Determination of bulk density, apparent porosity and true porosity.*

EN 843-1:1995, *Advanced technical ceramics — Monolithic ceramics — Mechanical properties at room temperature — Part 1: Determination of flexural strength.*

ASTM E 112:1995, *Estimating the average grain size of metals.*

ASTM C 323:1956(1995), *Test methods for chemical analysis of ceramic witheware clays.*

ASTM C 373:1988, *Test method for water absorption, bulk density, apparent porosity and apparent specific gravity of fired witheware products.*

ASTM C 573:1981(1990), *Chemical analysis of fireclay and high-alumina refractories.*

ASTM C 1161:1990, *Determination of the strength of advanced ceramics in 4-point bending.*

NOTE The ASTM references will be replaced by reference to appropriate International Standards when the latter become available.

## 3 Physical and chemical properties

The physical and chemical properties, when tested as specified in clause 4, shall comply with the values specified in Table 1.

**Table 1 — Physical and chemical properties**

Property	Unit	Requirement	Test method according to subclause
Bulk density	g/cm <sup>3</sup>	≥ 6,00	4.1
Chemical composition: ZrO <sub>2</sub> + HfO <sub>2</sub> + Y <sub>2</sub> O <sub>3</sub> Y <sub>2</sub> O <sub>3</sub> Hf <sub>2</sub> O <sub>3</sub> Al <sub>2</sub> O <sub>3</sub> Other oxides	percent mass fraction	> 99,0 4,5 to 5,4 ≤ 5 < 0,5 < 0,5	4.2
Microstructure: Mean linear intercept distance	μm	≤ 0,6	4.3
Strength <sup>a</sup> : Biaxial flexure or 4-point bending	MPa	≥ 500 ≥ 800	4.4 4.5
NOTE The radioactivity, defined as the sum of the massic activity of <sup>238</sup> U, <sup>226</sup> Ra, <sup>232</sup> Th and determined by gamma spectroscopy on the ready-to-use powder, should be less than 200 Bq/kg. This value will be reviewed at the next revision of this International Standard and will be based upon the radioactivity data from implant ceramic manufacturers.			
<sup>a</sup> Measured on a minimum of 10 samples.			

<sup>1)</sup> To be published. (Revision of ISO 5017:1988)

## 4 Test methods

### 4.1 Bulk density

The bulk density shall be determined in accordance with ISO 5017 or ASTM C 373 or ASTM E 112.

### 4.2 Chemical composition

The chemical composition shall be determined in accordance with ASTM C 323 or ASTM C 573, or by an equivalent method.

### 4.3 Microstructure

#### 4.3.1 Principle

For describing the microstructure, the average grain size is determined by measuring the linear intercept sizes.

#### 4.3.2 Apparatus

**4.3.2.1 Grinding and polishing devices**, to prepare plane and smooth surfaces.

**4.3.2.2 Furnace**, capable of maintaining a temperature of 1 400 °C.

**4.3.2.3 Scanning electron microscope**.

#### 4.3.3 Preparation of test piece

Prepare test pieces of the zirconia ceramic using methods representative of the method of production of parts for surgery, using the same precursor powder, pressing technique and pressure and firing conditions.

Grind one surface plane, polish it until the percentage of interpretable area is at least 90 % and thermally etch at a typical temperature from 1 300 °C to 1 400 °C, for 30 min to 60 min.

Coat the polished surface by sputtering with a thin metallic layer.

NOTE A gold or a gold-platinum alloy may be used.

#### 4.3.4 Procedure

Observe the microstructure using the scanning electron microscope at a magnification sufficient to clearly delineate grain boundaries. Using either lines drawn on photomicrographs or stage movement, follow the general procedure in ASTM E 112 to measure the linear intercept sizes of at least 250 grains in total over at least six fields of view on lines sufficiently long to encompass at least 20 grains, taking random orientations of measurement. Calibrate the magnification employed using a certified graticule or grid. Alternatively a calibrated stage micrometer may be used.

#### 4.3.5 Calculation of results

Calculate the mean linear intercept size and the standard deviation from the individual linear intercept sizes.

### 4.3.6 Test report

The test report shall contain at least the following information:

- a) identity of the ceramic material, details of batch number or other codes sufficient to uniquely identify the test pieces;
- b) method of preparation of the test pieces, including details of the machining procedure employed to prepare the test surfaces and of the etching procedure;
- c) mean linear intercept size and its standard deviation, expressed in micrometres.

## 4.4 Biaxial flexural strength

### 4.4.1 Principle

A disc of the test material is placed between two coaxial rings of unequal diameter and a compressive force is applied. The force applied at fracture of the test disc is recorded and the fracture stress is calculated.

### 4.4.2 Apparatus

**4.4.2.1 Mechanical testing machine**, suitable for applying a compressive load of at least 5 kN at a nominal loading rate of  $(500 \pm 100)$  N/s and equipped to record the peak force applied to an accuracy of better than 1 %. Calibration of the force-measuring device shall be performed according to agreed procedures (e.g. ISO 7500-1);

**4.4.2.2 Test jig**, comprising unequal diameter loading rings and having a geometry typically as shown in Figure 1. The jig shall have a support ring diameter of  $(30 \pm 0,1)$  mm at the diameter of contact with the test piece, and a loading ring mean diameter of  $(12 \pm 0,1)$  mm at the diameter of contact with the test piece. The radius of curvature of the test piece contact surface of the rings shall be  $(2,0 \pm 0,2)$  mm. The jig shall have a means of centring the loading and support rings and the test piece on a common axis to within  $\pm 0,2$  mm. Preferably the rings should be made of hardened steel ( $> HV 500$  or  $> HRC 40$ ) in order to minimize damage or roughness caused by fracture of the test pieces;

In order to accommodate slight departures from surface flatness of the test pieces, a  $(0,6 \pm 0,1)$  mm thick rubber plate with a Shore hardness of  $60 \pm 5$  shall be placed between the support ring and the test piece, and a piece of paper shall be placed between the test piece and the loading ring.

**4.4.2.3 Micrometer**, in accordance with ISO 3611, capable of measuring to an accuracy of  $\pm 0,01$  mm.



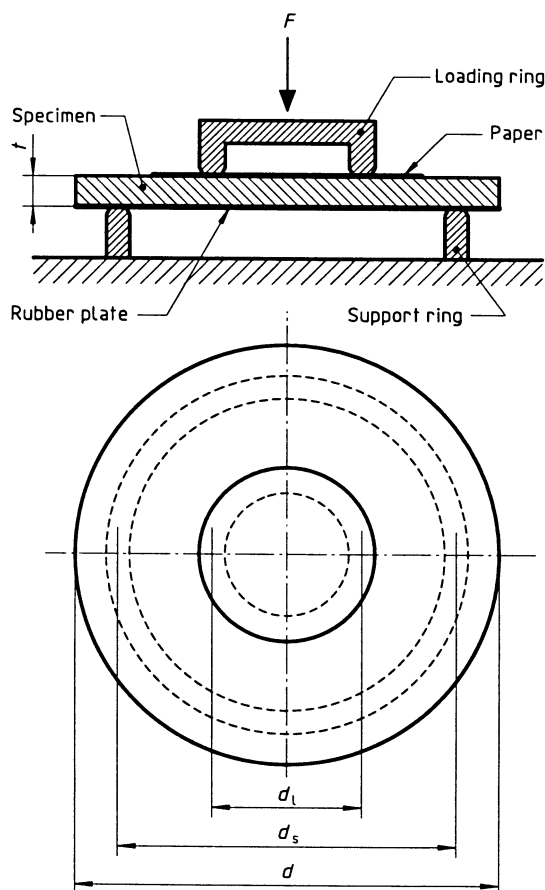

Figure 1 — Schematic diagram of the biaxial flexure testing device employing concentric loading and support rings

#### 4.4.3 Preparation of test piece

Prepare billets or discs of the zirconia ceramic using methods representative of the method of production of parts for surgery, using the same precursor powder, pressing technique and pressure and firing conditions;

Test pieces (see Figure 1) shall be circular plates of diameter  $(36,0 \pm 1,0)$  mm and thickness  $(2,0 \pm 0,1)$  mm. The surface to be tested shall be in the as-fired state;

At least 10 test pieces shall be prepared for determination of mean strength, or at least 30 test pieces if a Weibull statistical analysis is required.

#### 4.4.4 Procedure

Measure the diameter of the test piece to the nearest 0,1 mm and the thickness to the nearest 0,01 mm, each in at least three random positions. Calculate the mean diameter and mean thickness.

Place the rubber sheet on the support ring of the test jig. Place the test piece on the rubber sheet, with the surface to be tested in contact with the rubber, and centre it. Place a paper disc on the top of the test piece, place the loading ring on the paper and centre it relative to the test piece and support ring.

Apply a steadily increasing compressive force to the jig at a loading rate of  $(500 \pm 100)$  N/s until the test piece fractures. Record the load at fracture.

Inspect the fragments for evidence of the failure origin. If this is more than 0,5 mm outside the inner loading ring, note this fact in the report (4.4.6). For the purposes of calculation of the fracture stress, assume failure within the inner loading ring. Do not discard the result in calculating the mean strength of the test batch.

Repeat the procedure for each test piece in the batch.

#### 4.4.5 Calculation of results

For each test piece, calculate the nominal fracture stress,  $\sigma$ , in MPa, as:

$$\sigma = \frac{3F}{2\pi t^2} \left[ (1+\nu) \ln\left(\frac{d_s}{d_1}\right) + (1-\nu) \left(\frac{d_s^2 - d_1^2}{2d^2}\right) \right]$$

where

- $F$  is the force applied at fracture, in newtons;
- $t$  is the mean test piece thickness, in millimetres;
- $d_s$  is the support ring mean (contact) diameter, millimetres;
- $d_1$  is the loading ring mean (contact) diameter, in millimetres;
- $d$  is the test piece diameter, in millimetres;
- $\nu$  is Poisson's ratio for zirconia (assume to be 0,3).

Calculate the mean fracture stress and the standard deviation for the batch of test pieces.

#### 4.4.6 Test report

The test report shall contain at least the following information.

- a) The identity of the ceramic material, details of batch number or other codes sufficient to uniquely identify the test pieces;
- b) method of preparing the test pieces;
- c) mean value and standard deviation of the fracture stresses. If appropriate, the individual fracture stresses of the series of test pieces as well as Weibull statistical data may be given. The position of failure of test pieces shall be reported if this appears to fall outside the loading ring diameter (see 4.4.4).

#### 4.5 4-point bending strength

The 4-point bending strength shall be determined in accordance with ASTM C 1161 or EN 843-1.

The test pieces shall be  $\geq 45$  mm in length ( $4,0 \pm 0,2$ ) mm in width and ( $3,0 \pm 0,2$ ) mm in thickness. The test piece is supported by two parallel rollers of diameter ( $5,0 \pm 0,2$ ) mm. The two rollers shall be positioned symmetrically with respect to the length of the test piece with their centres ( $40 \pm 0,5$ ) mm apart (outer span).

The two loading rollers shall be symmetrically located with respect to the outer roller and shall have a span of ( $20 \pm 0,2$ ) mm.

---

**Annex A (informative)**  
**Bibliography**

[1] ISO 7500-1:1986, *Metallic materials — Verification of static uniaxial testing machine — Part 1: Tensile testing machines*.

[2] EN 623-2:1993, *Advanced technical ceramics — Monolithic ceramics — General and textural properties — Part 2: Determination of density and porosity*.

---

---

# BSI — British Standards Institution

BSI is the independent national body responsible for preparing British Standards. It presents the UK view on standards in Europe and at the international level. It is incorporated by Royal Charter.

## Revisions

British Standards are updated by amendment or revision. Users of British Standards should make sure that they possess the latest amendments or editions.

It is the constant aim of BSI to improve the quality of our products and services. We would be grateful if anyone finding an inaccuracy or ambiguity while using this British Standard would inform the Secretary of the technical committee responsible, the identity of which can be found on the inside front cover. Tel: 020 8996 9000. Fax: 020 8996 7400.

BSI offers members an individual updating service called PLUS which ensures that subscribers automatically receive the latest editions of standards.

## Buying standards

Orders for all BSI, international and foreign standards publications should be addressed to Customer Services. Tel: 020 8996 9001. Fax: 020 8996 7001.

In response to orders for international standards, it is BSI policy to supply the BSI implementation of those that have been published as British Standards, unless otherwise requested.

## Information on standards

BSI provides a wide range of information on national, European and international standards through its Library and its Technical Help to Exporters Service. Various BSI electronic information services are also available which give details on all its products and services. Contact the Information Centre. Tel: 020 8996 7111. Fax: 020 8996 7048.

Subscribing members of BSI are kept up to date with standards developments and receive substantial discounts on the purchase price of standards. For details of these and other benefits contact Membership Administration. Tel: 020 8996 7002. Fax: 020 8996 7001.

## Copyright

Copyright subsists in all BSI publications. BSI also holds the copyright, in the UK, of the publications of the international standardization bodies. Except as permitted under the Copyright, Designs and Patents Act 1988 no extract may be reproduced, stored in a retrieval system or transmitted in any form or by any means – electronic, photocopying, recording or otherwise – without prior written permission from BSI.

This does not preclude the free use, in the course of implementing the standard, of necessary details such as symbols, and size, type or grade designations. If these details are to be used for any other purpose than implementation then the prior written permission of BSI must be obtained.

If permission is granted, the terms may include royalty payments or a licensing agreement. Details and advice can be obtained from the Copyright Manager. Tel: 020 8996 7070.