



BSI Standards Publication

Electric cables – Thermosetting insulated and thermoplastic sheathed cables for voltages up to and including 450/750 V for electric power and lighting and having low emission of smoke and corrosive gases when affected by fire

NO COPYING WITHOUT BSI PERMISSION EXCEPT AS PERMITTED BY COPYRIGHT LAW

Publishing and copyright information

The BSI copyright notice displayed in this document indicates when the document was last issued.

© The British Standards Institution 2012

Published by BSI Standards Limited 2012

ISBN 978 0 580 75843 0

ICS 29.060.20

The following BSI references relate to the work on this standard:

Committee reference GEL/20/17

Draft for comment 12/30248745 DC

Publication history

First published September 1989

Second edition, March 1994

Third edition, October 1998

Fourth (present) edition, September 2012

Amendments issued since publication

Date	Text affected
------	---------------

Contents

1	Scope	1
2	Normative references	1
3	Terms and definitions	2
4	Rated voltage	3
5	Construction	4
6	Conductors	4
7	Insulation	4
8	Identification of cores	5
9	Multi-core circular cables	5
10	Optional extruded inner covering	6
11	Sheath	6
12	Cable marking and additional information	7
13	Schedule of tests	9
14	Test conditions	9
15	Routine tests	9
16	Sample tests	11
17	Type tests	12

Annexes

Annex A (informative)	Coding cross references	18
Annex B (informative)	Traditional UK cables transferred to BS EN 50525	19
Annex C (informative)	Guide to use	21
Annex D (normative)	Compatibility test	23
Annex E (normative)	Method of test for voltage withstand	24
Annex F (informative)	Notes on type tests	25

List of figures

Figure 1	An example of the marking as used on the outer sheath of the cable	8
----------	--	---

List of tables

Table 1	Maximum permitted voltages against rated voltage of cable	3
Table 2	Schedule of tests	10
Table 3	Thermosetting insulated, single-core, sheathed cables 6181B, 450/750 V	14
Table 4	Thermosetting insulated, circular 2-core 6182B, 3-core 6183B, 4-core 6184B, 5-core 6185B sheathed cables, 450/750 V	15
Table 5	Thermosetting insulated, single core 6241B, flat twin 6242B and flat 3-core 6243B sheathed cables with circuit protective conductor (CPC) 300/500 V	17
Table A.1	UK and harmonized CENELEC coding cross references	18
Table B.1	Halogen free, low smoke, conduit cable 450/750 V: formerly in BS 7211	19
Table B.2	Halogen free, low smoke, flexible conduit cable 450/750 V: formerly in BS 7211	20
Table B.3	Halogen free, low smoke, conduit cable 300/500 V: formerly in BS 7211	20
Table B.4	Halogen free low smoke flexible conduit cable 300/500 V: formerly in BS 7211	21
Table C.1	Constructional details, methods of installation and temperature for Table 3 to Table 5	22
Table C.2	Guide to use	23
Table D.1	Compatibility requirements	24

Summary of pages

This document comprises a front cover, an inside front cover, pages i to iv, pages 1 to 28, an inside back cover and a back cover.

Foreword

Publishing information

This British Standard is published by BSI Standards Limited, under licence from The British Standards Institution, and comes into effect on 1 January 2013. It was prepared by Subcommittee GEL/20/17, *Low voltage cables*, under the authority of Technical Committee GEL/20, *Electric cables*. A list of organizations represented on this committee can be obtained on request to its secretary.

Supersession

This British Standard supersedes BS 7211:1998 (incorporating Amendments Nos. 1 and 2), which is to be withdrawn on 31 December 2012.

Relationship with other publications

The new edition takes account of:

- BS EN 60228 (replacing BS 6360) on conductors;
- BS EN 50363-5 (replacing BS 7655-5.1) on materials;
- BS EN 50395 (replacing Annex B of BS 7211:1998) on electrical tests;
- BS EN 50396 (replacing BS 6469-99.1) on thickness measurement of sheath;
- BS EN 60332-1-2 (replacing BS EN 50265-2-1), BS EN 60332-3-24 (replacing BS EN 50266-2-4) and BS EN 61034-2 (replacing BS EN 50268-2) on reaction to fire performance tests;
- BS EN 62230 (replacing BS EN 50356) on spark testing.

Information about this document

In the preparation of BS 7211, GEL/20/17 has requested that references to other standards for which the committee is responsible are undated, even if referring to a specific clause. It is the committee's intention not to amend the fundamentals (e.g. clause numbers, material type designation) in any of these standards and so the latest edition applies.

This is a full revision of the standard, which has been revised due to the conversion of CENELEC Harmonization Documents HD 21 and HD 22 to BS EN 50525 (all parts). The previous edition of BS 7211 included a number of cable types that were harmonized and marked with CENELEC harmonized code designations. The following cables are now included in BS EN 50525 and withdrawn from BS 7211, which now only contains national types:

- thermosetting insulated, non-sheathed, single core, (H07Z-U, H07Z-R and H07Z-K) 450/750 V;
- thermosetting insulated, non-sheathed, single core, (H05Z-U and H05Z-K) 300/500 V.

The content of BS 7211 has been aligned with that found in BS EN 50525, where appropriate.

Annex A has been included to provide further clarification on where information from BS 7211:1998 has been moved to in this edition of BS 7211 and BS EN 50525-3-41. Annex B has been included to provide clarification on which cables have been transferred to BS EN 50525 (all parts).

The importance of the relationship between the traditional United Kingdom Cable Code (formerly known as the CMA coding) and its equivalent harmonized CENELEC code designations is emphasized. This additional information helps the user to choose the appropriate cable.

Product certification/inspection/testing. Users of this British Standard are advised to consider the desirability of third-party certification/inspection/testing of product conformity with this British Standard. Users seeking assistance in identifying appropriate conformity assessment bodies or schemes may ask BSI to forward their enquiries to the relevant association.

Hazard warnings

WARNING. This British Standard calls for the use of substances and/or procedures that can be injurious to health if adequate precautions are not taken. It refers only to technical suitability and does not absolve the user from legal obligations relating to health and safety at any stage.

Use of this document

It has been assumed in the preparation of this British Standard that the execution of its provisions will be entrusted to appropriately qualified and experienced people, for whose use it has been produced.

Presentational conventions

The provisions of this standard are presented in roman (i.e. upright) type. Its requirements are expressed in sentences in which the principal auxiliary verb is "shall".

Commentary, explanation and general informative material is presented in smaller italic type, and does not constitute a normative element.

Requirements in this standard are drafted in accordance with *The BSI guide to standardization – Section 2: Rules for the structure, drafting and presentation of British Standards*, subclause 11.3.1, which states, "Requirements should be expressed using wording such as: 'When tested as described in Annex A, the product shall ...'". This means that only those products that are capable of passing the specified test will be deemed to conform to this standard.

Presentational conventions

The provisions in this British Standard are presented in roman (i.e. upright) type. Its requirements are expressed in sentences in which the principal auxiliary verb is "shall".

Commentary, explanation and general informative material is presented in smaller italic type, and does not constitute a normative element.

Contractual and legal considerations

This publication does not purport to include all the necessary provisions of a contract. Users are responsible for its correct application.

Compliance with a British Standard cannot confer immunity from legal obligations.

1 Scope

This British Standard specifies requirements and test methods for the construction and performance of cables that:

- a) have a thermosetting insulation of rated voltage up to and including 450/750 V;
- b) emit limited amounts of smoke (see 16.6) and corrosive gases when subjected to relevant tests compared with corresponding PVC cables conforming to BS 6004;
- c) are intended for electric power and lighting.

The types of cable included in this British Standard are:

- thermosetting insulated and thermoplastic low smoke halogen free sheathed cable 450/750 V single core 6181B (see Table 3);
- thermosetting insulated and thermoplastic low smoke halogen free sheathed circular cables 450/750 V, 2-core 6182B, 3-core 6183B, 4-core 6184B and 5-core 6185B (see Table 4);
- thermosetting insulated and thermoplastic low smoke halogen free sheathed cables 300/500 V single-core 6241B, flat twin 6242B, flat 3-core 6243B with circuit protective conductor (see Table 5).

The insulation and other components are suitable to permit operation of the cables at a maximum sustained conductor temperature of 90 °C and for a maximum short-circuit conductor temperature of 250 °C (for a maximum period of 5 s).

NOTE 1 Limitation on the temperature of the cables may be imposed in situations where they could be touched, or where they could touch other materials.

NOTE 2 In installations that include wiring accessories, junction boxes and consumer units etc., the performance of these accessories should be taken into account in deciding the maximum operating temperature of the cable.

NOTE 3 Annex A provides a guide to the cross-referencing of the traditional United Kingdom Cable Codes (formerly known as the CMA codes) and harmonized CENELEC codes. Furthermore, Annex B gives information on the traditional UK cables transferred to BS EN 50525.

NOTE 4 Annex C gives guidance on the use of the cables specified in this British Standard.

NOTE 5 Annex D gives the compatibility test method.

NOTE 6 Annex E gives the voltage withstand test.

NOTE 7 Annex F gives notes on type tests.

NOTE 8 In this British Standard, corrosive (and acid) gases are defined as those that are determined as HCl.

2 Normative references

The following documents, in whole or in part, are normatively referenced in this document and are indispensable for its application. For dated references, only the edition cited applies. For undated references, the latest edition of the referenced document (including any amendments) applies.

BS 5099, *Electric cables – Voltage levels for spark testing*

BS 7655-1.3, *Specification for insulating and sheathing materials for cables – Part 1: Cross-linked elastomeric insulating compounds – Section 1.3: XLPE*

BS 7655-6.1, *Specification for insulating and sheathing materials for cables – Part 6: Thermoplastic sheathing compounds having low emission of corrosive gases, and suitable for use in cables having low emission of smoke when affected by fire – Section 6.1: General application thermoplastic types*

BS EN 50267-2-1, *Common test methods for cables under fire conditions – Tests on gases evolved during combustion of materials from cables – Part 2-1: Procedures – Determination of the amount of halogen acid gas*

BS EN 50363-5, *Insulating, sheathing and covering materials for low voltage energy cables – Part 5: Halogen-free, cross-linked insulating compounds*

BS EN 50395, *Electrical test methods for low voltage energy cables*

BS EN 50396, *Non electrical test methods for low voltage energy cables*

BS EN 60228, *Conductors of insulated cables*

BS EN 60332-1-2:2004, *Tests on electric and optical fibre cables under fire conditions – Part 1-2: Test for vertical flame propagation for a single insulated wire or cable – Procedure for 1 kW pre-mixed flame*

BS EN 60332-3-24:2009, *Tests on electric and optical fibre cables under fire conditions – Part 3-24: Test for vertical flame spread of vertically-mounted bunched wires or cables – Category C*

BS EN 60811-401, *Electric and optical fibre cables – Test methods for non-metallic materials – Part 401: Environmental tests – Thermal ageing methods – Ageing in an air oven*

BS EN 60811-501, *Electric and optical fibre cables – Test methods for non-metallic materials – Part 501: Mechanical tests – Tests for determining the mechanical properties of insulating and sheathing compounds*

BS EN 60811-502, *Electric and optical fibre cables – Test methods for non-metallic materials – Part 502: Mechanical tests – Shrinkage test for insulations*

BS EN 61034-2, *Measurement of smoke density of cables burning under defined conditions – Part 2: Test procedure and requirements*

BS EN 62230, *Electric cables – Spark-test method*

IEC 60050-461, *International Electro technical Vocabulary – Part 461: Electric cables*

3 Terms and definitions

For the purposes of this British Standard, the terms and definitions given in IEC 60050-461 and the following apply.

3.1 cable manufacturer

organization that has the capability to both produce and control the conformity of cable made to this British Standard

NOTE See 12.1a) for information on marking the cable with the cable manufacturer's name and identifier.

3.2 length of lay

axial length of one complete turn of the helix formed by one cable component

3.3 routine tests, R

tests made on all production lengths of cable to demonstrate their integrity

3.4 sample tests, S

tests made on samples of completed cable, or components taken from a completed cable, adequate to verify that the product meets the design specifications

3.5 type tests, T

tests made before supplying, on a general commercial basis, a type of cable covered by this British Standard, in order to demonstrate satisfactory performance characteristics to meet the intended application

NOTE These tests are of such a nature that, after they have been made, they need not be repeated unless changes are made in the cable materials, design or type of manufacturing process, which might change the performance characteristics.

3.6 values**3.6.1 approximate value**

value which is only indicative

NOTE Values described as "approximate" do not constitute requirements to be checked by measurement.

3.6.2 nominal value

value by which a quantity is designated

NOTE Nominal values usually give rise to values to be checked by measurements taking into account specified tolerances.

3.7 voltages**3.7.1 maximum voltage, U_m**

maximum sustained power-frequency voltage between phase conductors for which the cable is suitable

3.7.2 rated voltage, U_0

nominal power-frequency voltage between conductor(s) and earth for which the cable is suitable

3.7.3 rated voltage, U

nominal power-frequency voltage between phase conductors for which the cable is suitable

4 Rated voltage

The cables shall be designated by the rated voltages U_0 and U , expressed in the form U_0/U . The rated voltages recognized for the purpose of this British Standard shall be 300/500 V and 450/750 V.

The maximum permanent permitted operating voltages of the system shall be in accordance with Table 1.

Table 1 Maximum permitted voltages against rated voltage of cable

Rated voltage of cable	Maximum permanent permitted operating voltage of the system			
	a.c.		d.c.	
	Conductor-earth	Conductor-conductor	Conductor-earth	Conductor-conductor
U_0/U (V)	U_0 max (V)	U_m (V)	V	V
300/500	320	550	410	820
450/750	480	825	620	1 240

5 Construction

The construction of the cables shall be as specified in Table 3 to Table 5.

6 Conductors

The conductors shall be annealed copper conforming to BS EN 60228. The class of conductor shall be as given in Table 3 to Table 5.

7 Insulation

7.1 Type of insulation

The insulation shall be one of the following types, in accordance with Table 3 to Table 5:

- GP 8, as specified in BS 7655-1.3;
- EI 5, as specified in BS EN 50363-5.

NOTE 1 BS EN 50363-5 specifies various requirements for assessing the insulation's corrosive and acid gas emission. To conform to this British Standard, corrosive and acid gas emission should only be tested in accordance with 7.4, regardless of insulation types.

NOTE 2 A tape or tapes can be applied over either the conductor or the insulation.

7.2 Application

The insulation shall be applied by an extrusion process to form a compact and homogeneous layer.

NOTE 1 The insulation can be applied in a single layer, or in a number of cohesive layers.

Where more than one layer is used, all testing specified in this British Standard shall be carried out on the complete insulation as though it were a single layer of the declared insulation type (see 7.1).

NOTE 2 Insulation applied in more than one layer does not conform to the definition of "double insulation" given, for instance, in BS 7671.

When the application is tested by removing the insulation from the conductor, there shall be no damage to the insulation itself or the conductor.

7.3 Thickness

The mean value of the radial thickness of the insulation, when measured in accordance with BS EN 50396, 4.1, shall be not less than the value given in Table 3 to Table 5. The smallest value measured, t_m , shall not fall below 90% of the value given in Table 3 to Table 5 by more than 0.1 mm, i.e.:

$$t_m \geq 0.9t_n - 0.1$$

where:

t_m is the smallest value measured, in millimetres (mm);

t_n is the tabulated radial thickness, in millimetres (mm).

The thickness of any tape(s) over either the conductor or the insulation shall not be included in the measurement of insulation thickness.

7.4 Corrosive and acid gas emission from insulation and tape(s)

When tested in accordance with BS EN 50267-2-1, the level of HCl shall be not greater than 0.5%.

8 Identification of cores

8.1 General

The cores of all cables shall be identified by colour. Each core shall be identified by its colour as indicated in Table 3 to Table 5.

NOTE Other colours may be used by agreement with the manufacturer; in this case the requirements in 12.2 do not apply.

8.2 Core colours

The colour shall be applied throughout either the whole insulation or the outer cohesive layer and shall be applied as part of the extrusion process.

The insulation of the coloured cores, irrespective of the method of colouring, shall be tested as a complete single layer (see 7.2).

The colours of the cores, determined by the number of cores in the cable, and also the sequence of the colours shall be as given in Table 3 to Table 5. Where alternative colours are used (see 8.1, Note), the sequence shall be agreed with the manufacturer.

On a core with the bi-colour combination of green-and-yellow, the distribution of these colours shall be such that for every 15 mm length of core, one of the colours shall cover not less than 30% and not more than 70% of the surface of the core, while the other colour shall cover the remainder of the surface. Conformity shall be checked by measurement.

NOTE 1 In cases of dispute regarding the green-and-yellow combination, and where appropriate to the method of colour marking of the insulation, a suitable test method for checking conformity is given in BS EN 50396, 5.2.

NOTE 2 It is understood that the colours green and yellow, when they are combined as specified, are recognized as identifying exclusively the core intended for use as an earth connection or similar protection. The colour blue is for the identification of the core intended to be connected to neutral but, if there is no neutral, blue may be used to identify any core except for the earth or protective conductor.

NOTE 3 Depending on where the cables are used, restrictions may apply to the use of certain colours for some applications.

8.3 Clarity and durability

The colour used for core identification shall be clearly identifiable and durable such that it cannot be removed when tested in accordance with BS EN 50396, 5.1.

9 Multi-core circular cables

9.1 Assembly and core colour sequence

The cores of 2-core, 3-core, 4-core and 5-core circular cables shall be laid up together. Cores shall be laid up in the sequence of colours as given in Table 4. If alternative core colours to those specified in Table 4 are used, then an alternative sequence shall be agreed with the manufacturer.

Conformity shall be checked by visual examination.

The maximum length of lay for circular cables shall be not more than 25 times the diameter of the assembly of laid up cores.

Conformity shall be checked in accordance with **16.7**.

If necessary, a compact and reasonably circular cable shall be formed by one of the following methods:

- the application of synthetic fillers; or
- the application of binder tape(s); or
- a combination of both.

It shall be possible to strip the fillers and/or tape(s) from the cable without damaging the insulation of the cores.

9.2 Corrosive and acid gas emission from binder tape(s) and fillers

When tested in accordance with BS EN 50267-2-1, the level of HCl of any filler or binder tape(s) shall be not greater than 0.5%.

10 Optional extruded inner covering

10.1 General

NOTE 1 The manufacturer has the option to include, or not, an inner covering for cables in Table 4.

Where used, an optional inner covering shall consist of an extruded layer of synthetic polymeric material compatible with the operating temperature of the cable. It shall surround the laid-up 2-, 3-, 4- and 5-cores, giving a practically circular shape. The inner covering shall not adhere to the cores.

NOTE 2 An approximate value of thickness of any inner covering is given in Table 4.

It shall be possible to remove the inner covering without damaging the insulation of the cores.

NOTE 3 Tape may be applied over any optional extruded inner covering.

10.2 Corrosive and acid gas emission from inner covering and tape(s)

When tested in accordance with BS EN 50267-2-1, the level of HCl of the extruded inner covering and any tape(s) shall be not greater than 0.5%.

11 Sheath

11.1 Type of sheath

The sheath shall be an extruded layer of synthetic material of one of the following types, in accordance with Table 3 to Table 5:

- LTS 2, as specified in BS 7655-6.1;
- LTS 4, as specified in BS 7655-6.1.

11.2 Application

The sheath shall be applied by an extrusion process.

NOTE The sheath can be applied in a single layer or in a number of cohesive layers.

Where more than one layer is used, all testing specified in this British Standard shall be carried out on the complete sheath as though it were a single layer of the declared sheath type (see 11.1).

When the sheath is removed, there shall be no damage to the core insulation when visually checked.

11.3 Thickness

When measured in accordance with BS EN 50396, 4.2 or 4.3, as applicable, the smallest value, t_m , of the radial thickness of the sheath shall not fall below 85% of the value given in Table 3 to Table 5 by more than 0.1 mm, i.e.:

$$t_m \geq 0.85t_n - 0.1$$

where:

- t_m is the smallest value measured, in millimetres (mm);
- t_n is the tabulated radial thickness, in millimetres (mm).

11.4 Colour

The colour shall be applied throughout either the whole sheath or the outer cohesive layer and shall be applied as part of the extrusion process.

The sheath, irrespective of the method of colouring, shall be tested as a complete single layer (see 11.2).

The colour of the sheath shall be as specified in Table 3 to Table 5.

11.5 Corrosive and acid gas emission from sheath

When tested in accordance with BS EN 50267-2-1, the level of HCl of the sheath shall be not greater than 0.5%.

12 Cable marking and additional information

12.1 External marking

The external surface of all cables conforming to this British Standard shall be legibly marked with the following elements:

Element	Example of marking
a) Cable manufacturer	Manufacturer's name and their unique factory identifier
<i>NOTE 1 A simplified version of the manufacturer's name, or a trading name of the manufacturer, may be used in place of the full name.</i>	
<i>NOTE 2 Any suitable method may be used to unambiguously identify the manufacturer's factory.</i>	
<i>NOTE 3 The manufacturer's own trademark or equivalent may be added but this cannot be used instead of the manufacturer's name or identifier.</i>	
b) Electric cable	ELECTRIC CABLE
c) Voltage designation	300/500 V or 450/750 V ¹⁾

¹⁾ 300/500 V indicates a cable conforming to Table 5; 450/750 V indicates a cable conforming to Table 3 or Table 4.

- | | | |
|----|---|--|
| d) | British Standard number | BS 7211 ²⁾ |
| e) | UK cable code | 6242B |
| | <i>NOTE 4 The relevant UK cable code is given in Tables 3 to 5.</i> | |
| f) | Number of cores, nominal area of conductor and CPC as appropriate | i) 3×1.5 ³⁾ |
| | | ii) $2 \times 1.5 + 1.0$ ⁴⁾ |
| g) | Year of manufacture | ZZZZ |
| | <i>NOTE 5 The year of manufacture may take the form of the actual year (e.g. 2013) or a coded year identifier assigned by the manufacturer.</i> | |
| h) | Standard core colour identifier | H |
| | <i>NOTE 6 See 12.2.</i> | |

The marking of items a) to h) shall be by embossing or indenting on the sheath. The markings shall appear along the axis of the cable in any sequence that is deemed to neither confuse nor conflict.

NOTE 7 The order in which the elements of marking appear along the length of the external sheath is not prescribed, but it is preferred that they be in the order a) to h) as shown in this subclause.

The letters and figures shall consist of upright, block characters.

The distance between the end of one element of the marking and the beginning of the next identical element of the marking shall be not more than 550 mm in accordance with Figure 1.

Figure 1 An example of the marking as used on the outer sheath of the cable

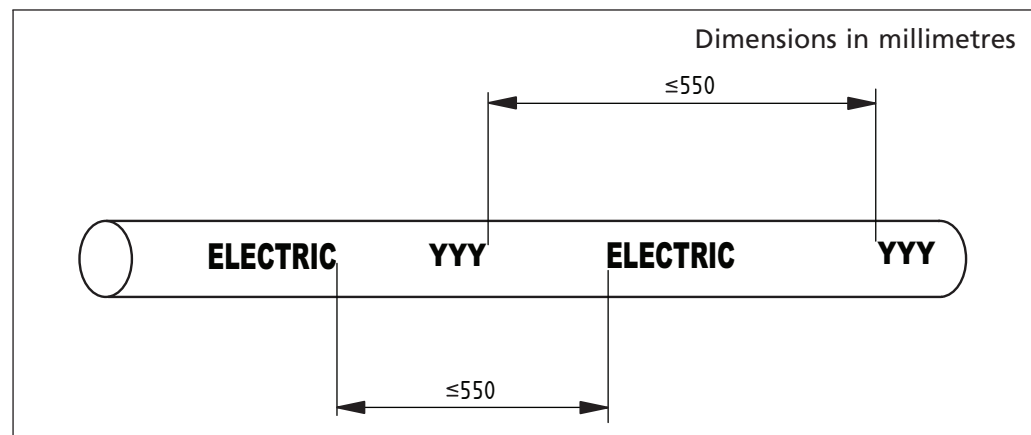

Conformity of the marking shall be checked by visual examination and measurement of at least two sets of elements.

- ²⁾ Marking BS 7211 or BS 7211:2012 on or in relation to a product represents a manufacturer's declaration of conformity, i.e. a claim by or on behalf of the manufacturer that the product meets the requirements of the standard. The accuracy of the claim is solely the claimant's responsibility. Such a declaration is not to be confused with third-party certification of conformity.
- ³⁾ 3×1.5 indicates a 3-core cable with 1.5 mm^2 conductors.
- ⁴⁾ $2 \times 1.5 + 1.0$ indicates a 2-core cable with 1.5 mm^2 conductors and a 1.0 mm^2 circuit protective conductor.

12.2 Standard core colour identifier

When the core colour combinations are used in accordance with Table 3 to Table 5, the letter "H" shall be included in the marking on the external sheath of the cable in accordance with 12.1.

12.3 The mark of an approval organization

If the mark of an approval organization is used, it shall be embossed or indented throughout the length of the external sheath of the cable.

The mark shall be in the form of symbol(s) specified by the approval organization, and the maximum distance between marks shall be not greater than 1 100 mm.

12.4 Additional information

Any additional information shall be embossed, indented or printed throughout the length of the external sheath of the cable.

The additional information shall be in one continuous string such that it does not conflict with, confuse nor render illegible the marking in 12.1, 12.2 and 12.3. The repeat interval shall not exceed 1 100 mm.

Where the information is applied by printing, it shall be durable such that it cannot be removed when tested in accordance with BS EN 50396, 5.1.

13 Schedule of tests

The tests to be performed on cables specified in this British Standard shall be as scheduled in Table 2, which refers to the relevant clauses of the standard specifying the requirements and test methods as well as the category of each test that applies, i.e. T, S or R (as defined in Clause 3).

14 Test conditions

14.1 Temperature

Tests shall be performed at a temperature of (20 ± 15) °C unless otherwise specified in the details for a particular test.

14.2 Frequency and waveform of power frequency test voltages

The frequency of the alternating test voltages shall be in the range of 49 Hz to 61 Hz, unless otherwise specified for a particular test. The waveform shall be substantially sinusoidal.

15 Routine tests

COMMENTARY ON Clause 15

In some tests, the preparation and presentation of the test sample can have a critical affect on the result of the tests so test samples should always be prepared carefully.

15.1 General

Routine tests shall be performed in accordance with Table 2 as indicated by the symbol "R" in column 4.

NOTE The requirements for routine testing that are not fully covered by earlier clauses are detailed in 15.2 and 15.3.

Table 2 Schedule of tests

Test	Requirements given in clause	Test method	Test category
Conductor construction	Clause 6	BS EN 60228	S
Insulation:			
• material	7.1	BS 7655-1.3 or BS EN 50363-5	T
• application	7.2	Visual examination and manual test	S
• thickness	7.3	BS EN 50396, 4.1	S
• corrosive and acid gas	7.4	BS EN 50267-2-1	T
Core identification:			
• colour	8.2	Visual examination	S
• clarity and durability	8.3	BS EN 50396, 5.1	S
• assembly and core colour sequence	9.1	Visual examination	S
Length of lay of assembled cores	9.1	16.7	S
Fillers and binders:			
• assembly	9.1	Visual examination	S
• corrosive and acid gas	9.2	BS EN 50267-2-1	T
Optional inner covering:			
• application	10.1	Visual Examination	S
• corrosive and acid gas	10.2	BS EN 50267-2-1	T
Sheath:			
• material	11.1	BS 7655-6.1	T
• application	11.2	Visual examination	S
• thickness	11.3	BS EN 50396, 4.2 or 4.3	S
• colour	11.4	Visual examination	S
• corrosive and acid gas	11.5	BS EN 50267-2-1	T
Cable marking	Clause 12	Visual examination and measurement	S
Durability of printed information	12.4	BS EN 50396, 5.1	T
Conductor resistance	15.2	BS EN 60228	R
Absence of faults on the insulation	15.3	BS EN 62230; BS EN 50395, 10.3	R
Mean overall dimensions	16.2	BS EN 50396, 4.4	S
Ovality	16.3	BS EN 50396, 4.4	S
Voltage withstand	16.4	Annex E	S
Flame propagation on single cable	16.5	BS EN 60332-1-2, Annex A	S
Smoke emission	16.6	BS EN 61034-2	S
Insulation resistance at 90 °C	17.2	BS EN 50395, 8.1	T
Voltage test on cores	17.3	BS EN 50395, Clause 7	T
Compatibility	17.4	Annex D	T
Vertical flame spread of bunched wires and cables	17.5	BS EN 60332-3-24	T
Shrinkage test on insulation	17.6	BS EN 60811-502	T

NOTE 1 Tests classified as sample (S) or routine (R) might be required as part of a type approval scheme.

NOTE 2 The order of the tests in this schedule does not imply a sequence of testing.

15.2 Conductor resistance

The d.c. resistance of each conductor shall conform to BS EN 60228 when measured in accordance with BS EN 60228, Annex A, and corrected to 20 °C. The measurement shall be made on a complete drum length or on a 1 m sample taken from the drum.

15.3 Test to check the absence of faults on the insulation

15.3.1 Test for single core circular cable

The completed single-core circular cable shall be tested in accordance with the a.c. or d.c. test method in BS EN 62230 at the test voltage given in BS 5099, 5.3, (insulation and sheath combined) and there shall be no breakdown of the insulation or sheath.

15.3.2 Test for flat cable and multi-core circular cable

The completed 300/500 V flat cable shall be tested in accordance with BS EN 50395, 10.3, having either a test voltage of 2 000 V a.c. r.m.s. or 5 000 V d.c., for 5 min and there shall be no breakdown of the insulation.

The completed 450/750 V multi-core circular cable shall be tested in accordance with BS EN 50395, 10.3, having either a test voltage of 2 500 V a.c. r.m.s. or 6 000 V d.c., for 5 minutes and there shall be no breakdown of the insulation.

Single-core flat cable with an uninsulated circuit protective conductor (6241B) shall have the test voltage applied to the core, and the uninsulated circuit protective conductor shall be earthed.

16 Sample tests

COMMENTARY ON Clause 16

In some tests, the preparation and presentation of the test sample can have a critical affect on the result of the tests so test samples should always be prepared carefully.

16.1 General

Sample tests shall be performed in accordance with Table 2 as indicated by the symbol "S" in column 4.

NOTE The requirements for sample testing that are not fully covered by earlier clauses are detailed in 16.2, 16.3, 16.4, 16.5, 16.6 and 16.7.

16.2 Mean overall dimensions

When tested in accordance with BS EN 50396, 4.4, the mean overall diameter of circular cables and the mean overall dimensions of flat cables shall be within the limits specified in Table 3 to Table 5.

A test sample shall be taken from a cable from three places, separated by at least 1 m. For circular cables, the mean of the six values obtained shall be taken as the mean overall diameter. For flat cables, the mean of each set of three values, for the major and minor axis, respectively, shall be taken as the relevant overall dimension.

16.3 Ovality of circular cables

The difference between any two values of the overall diameter of circular sheathed cables at the same cross-section shall be not more than 15% of the upper limit for the mean overall diameter given in Table 3 and Table 4 when tested in accordance with BS EN 50396, 4.4.

A test sample shall be taken from a cable from three places, separated by at least 1 m.

Two measurements shall be taken at the same cross-section of the cable, covering the maximum and minimum values.

16.4 Voltage withstand

When tested in accordance with Annex E, no breakdown of the insulation shall occur.

16.5 Flame propagation on single cable

When tested in accordance with BS EN 60332-1-2, the completed cable shall conform to BS EN 60332-1-2:2004, Annex A.

16.6 Smoke emission

When tested in accordance with BS EN 61034-2, as a flat horizontal unit, the smoke generated shall result in transmittance values of not less than 60%.

16.7 Length of lay

The length of lay shall be determined by measuring the length of two pitches of a laid up assembly taken from a sample of cable and calculating the average of these two lengths. The result shall be taken as the length of lay of the laid-up cores.

17 Type tests

COMMENTARY ON Clause 17

In some tests, the preparation and presentation of the test sample can have a critical effect on the result of the tests, so test samples should always be prepared carefully.

17.1 General

Type tests shall be performed in accordance with Table 2 as indicated by the symbol "T" in column 4.

NOTE 1 The requirements for type testing that are not fully covered by earlier clauses are detailed in 17.2, 17.3, 17.4, 17.5, and 17.6.

NOTE 2 Informative notes on type tests can be found in Annex F.

17.2 Insulation resistance

When the cores are tested in accordance with BS EN 50395, 8.1, under the following conditions:

- a) period of immersion in water: minimum 2 h;
- b) temperature of water for cables: (90 ± 2) °C;

none of the resulting values shall be below the minimum insulation resistance value specified in Table 3 to Table 5.

17.3 Voltage test on cores

When the cores are tested in accordance with BS EN 50395, Clause 7, under the following conditions:

- a) period of immersion in water: minimum 1 h;
- b) temperature of water: (20 ± 5) °C;

- c) applied voltage (a.c.) according to the voltage rating as specified below:
- 2 000 V for 300/500V cable or;
 - 2 500 V for 450/750 V cable;
- d) duration of each application of voltage; minimum 5 min;
- there shall be no breakdown of the insulation.

17.4 Compatibility

When a sample of complete cable is aged in accordance with **D.2**, the insulation and the outer sheath shall conform to the requirements given in Table D.1. In addition, at the end of the test period in the oven, the blotting paper shall be free of stains.

17.5 Vertical flame spread of vertically-mounted bunched wires or cables

When tested in accordance with BS EN 60332-3-24, cables in Table 4 shall conform to BS EN 60332-3-24:2009, Annex B.

17.6 Shrinkage test on insulation

All grades of insulation shall be tested in accordance with BS EN 60811-502 on a 200 mm sample of core at (130 ± 2) °C for 1 h, and the shrinkage of the insulation shall not exceed 4%.

Table 3 Thermosetting insulated, single-core, sheathed cables 6181B, 450/750 V

Construction:

- annealed copper conductor, class 1 and class 2 as shown in column 2;
- thermosetting insulation either type EI 5 or type GP 8.

Colours for core identification:

- brown;
- blue.

Synthetic sheath type:

- LTS 4.

Colour of sheath:

- white (other colours may be used by agreement between manufacturer and customer).

Nominal cross-sectional area of conductor mm ²	Class of conductor	Radial thickness of insulation mm	Radial thickness of sheath mm	Mean overall diameter		Min. insulation resistance at 90 °C MΩ.km
				Lower limit mm	Upper limit mm	
6181B 1 × 1.0	1	0.7	0.8	3.9	4.8	0.011
	2	0.7	0.8	4.0	4.9	0.011
1 × 1.5	1	0.7	0.8	4.2	5.0	0.011
	2	0.7	0.8	4.3	5.2	0.010
1 × 2.5	1	0.7	0.8	4.6	5.5	0.0092
	2	0.7	0.8	4.7	5.6	0.0084
1 × 4.0	1	0.7	0.9	5.2	6.3	0.0077
	2	0.7	0.9	5.3	6.4	0.0070
1 × 6.0	1	0.7	0.9	5.7	6.8	0.0065
	2	0.7	0.9	5.9	7.1	0.0059
1 × 10	2	0.7	0.9	6.7	8.1	0.0047
1 × 16	2	0.7	0.9	7.6	9.2	0.0039
1 × 25	2	0.9	1.0	9.4	11.4	0.0039
1 × 35	2	0.9	1.1	10.6	12.8	0.0034

Table 4 Thermosetting insulated, circular 2-core 6182B, 3-core 6183B, 4-core 6184B, 5-core 6185B sheathed cables, 450/750 V

Construction:

- annealed copper conductor, class 1 and class 2 as shown in column 2;
- thermosetting insulation either type EI 5 or type GP 8;
- the cores shall be laid up together. Centre filler may be used;
- the laid up cores may be covered by an optional extruded inner covering or separating tape as specified in Clause 10. It shall be possible to separate the cores easily.

Colours for core identification:

- 2-core: brown and blue;
- 3-core: brown, black and grey;
- 4-core: blue, brown, black and grey;
- 5-core: green/yellow, blue, brown, black and grey.

Optional inner covering:

- the thickness of the inner covering is given for guidance and is not measured.

Synthetic sheath type:

- LTS 4.

Colour of sheath:

- white (other colours may be used by agreement between manufacturer and customer).

Nominal cross-sectional area of conductor mm ²	Class of conductor	Radial thickness of insulation mm	Approximate thickness of optional inner covering mm	Radial thickness of sheath mm	Mean overall diameter		Min. insulation resistance at 90 °C MΩ.km
					Lower limit mm	Upper limit mm	
6182B							
2 × 1.0	1	0.7	0.4	1.2	7.1	9.5	0.011
	2	0.7	0.4	1.2	7.3	9.7	0.011
2 × 1.5	1	0.7	0.4	1.2	7.6	10.1	0.011
	2	0.7	0.4	1.2	7.8	10.3	0.010
2 × 2.5	1	0.7	0.4	1.2	8.4	11.0	0.0092
	2	0.7	0.4	1.2	8.5	11.3	0.0084
2 × 4.0	1	0.7	0.4	1.2	9.2	12.1	0.0077
	2	0.7	0.4	1.2	9.5	12.4	0.0070
2 × 6.0	1	0.7	0.4	1.2	10.2	13.2	0.0065
	2	0.7	0.4	1.2	10.6	13.7	0.0059
2 × 10	1	0.7	0.4	1.4	12.1	16.0	0.0053
	2	0.7	0.6	1.4	12.7	16.7	0.0047
2 × 16	2	0.7	0.6	1.4	14.4	18.8	0.0039
2 × 25	2	0.9	0.8	1.4	17.7	23.2	0.0039
2 × 35	2	0.9	0.8	1.6	20.0	26.0	0.0034
6183B							
3 × 1.0	1	0.7	0.4	1.2	7.5	10.0	0.011
	2	0.7	0.4	1.2	7.7	10.2	0.011

Table 4 Thermosetting insulated, circular 2-core 6182B, 3-core 6183B, 4-core 6184B, 5-core 6185B sheathed cables, 450/750 V

3 × 1.5	1	0.7	0.4	1.2	8.0	10.6	0.011
	2	0.7	0.4	1.2	8.2	10.9	0.010
3 × 2.5	1	0.7	0.4	1.2	8.8	11.6	0.0092
	2	0.7	0.4	1.2	9.0	11.9	0.0084
3 × 4.0	1	0.7	0.4	1.2	9.8	12.7	0.0077
	2	0.7	0.4	1.2	10.1	13.1	0.0070
3 × 6.0	1	0.7	0.4	1.2	11.2	14.4	0.0065
	2	0.7	0.4	1.4	11.6	15.0	0.0059
3 × 10	1	0.7	0.6	1.4	12.8	16.9	0.0053
	2	0.7	0.6	1.4	13.5	17.7	0.0047
3 × 16	2	0.7	0.6	1.4	15.3	19.9	0.0039
3 × 25	2	0.9	0.8	1.4	18.9	24.6	0.0039
3 × 35	2	0.9	0.8	1.6	21.3	27.6	0.0034
6184B							
4 × 1.0	1	0.7	0.4	1.2	8.1	10.7	0.011
	2	0.7	0.4	1.2	8.3	11.0	0.011
4 × 1.5	1	0.7	0.4	1.2	8.7	11.4	0.011
	2	0.7	0.4	1.2	8.9	11.7	0.010
4 × 2.5	1	0.7	0.4	1.2	9.6	12.6	0.0092
	2	0.7	0.4	1.2	9.9	12.8	0.0084
4 × 4.0	1	0.7	0.4	1.2	10.7	13.8	0.0077
	2	0.7	0.4	1.2	11.0	14.2	0.0070
4 × 6.0	1	0.7	0.4	1.4	12.2	16.1	0.0065
	2	0.7	0.6	1.4	12.7	16.7	0.0059
4 × 10	1	0.7	0.6	1.4	14.1	18.4	0.0053
	2	0.7	0.6	1.4	14.8	19.2	0.0047
4 × 16	2	0.7	0.6	1.4	16.9	21.8	0.0039
4 × 25	2	0.9	0.8	1.6	21.2	27.5	0.0039
4 × 35	2	0.9	1.0	1.6	23.5	30.7	0.0034
6185B							
5 × 1.0	1	0.7	0.4	1.2	8.8	11.5	0.011
	2	0.7	0.4	1.2	9.0	11.9	0.011
5 × 1.5	1	0.7	0.4	1.2	9.4	12.3	0.011
	2	0.7	0.4	1.2	9.7	12.6	0.010
5 × 2.5	1	0.7	0.4	1.2	10.5	13.6	0.0092
	2	0.7	0.4	1.2	10.7	13.9	0.0084
5 × 4.0	1	0.7	0.4	1.4	12.0	15.9	0.0077
	2	0.7	0.6	1.4	12.4	16.4	0.0070
5 × 6.0	1	0.7	0.6	1.4	13.3	17.5	0.0065
	2	0.7	0.6	1.4	13.8	18.1	0.0059
5 × 10	1	0.7	0.6	1.4	15.4	20.0	0.0053
	2	0.7	0.6	1.4	16.2	20.9	0.0047
5 × 16	2	0.7	0.8	1.4	18.5	24.2	0.0039
5 × 25	2	0.9	1.0	1.6	23.3	30.5	0.0039
5 × 35	2	0.9	1.0	1.6	25.9	33.6	0.0034

Table 5 Thermosetting insulated, single core 6241B, flat twin 6242B and flat 3-core 6243B sheathed cables with circuit protective conductor (CPC) 300/500 V

Construction:

- annealed copper conductor, class 1 and class 2 as shown in column 2;
- thermosetting insulation either type EI 5 or type GP 8;
- the core or cores shall be laid parallel with the uninsulated CPC.

Colours of core identification:

- single core: brown or blue;
- twin: brown and blue or, for 2 × 1.0 and 2 × 1.5 cables, brown and brown;
- 3-core: brown, black (centre core) and grey.

Position of CPC:

- twin: centrally placed between cores in same plane;
- 3-core: centrally placed between black and grey cores in same plane.

Synthetic sheath type:

- LTS 2.

Colour of sheath:

- white (other colours may be used by agreement between manufacturer and customer).

Nominal cross-sectional area of conductor mm ²	Class of conductor	Radial thickness of insulation mm	Radial thickness of sheath mm	Mean overall dimensions		CPC cross-sectional area mm ²	Class of CPC	Min. insulation resistance at 90 °C MΩ.km
				Lower limit mm	Upper limit mm			
6241B								
1 × 1.0	1	0.7	0.9	4.1 × 5.2	5.0 × 6.3	1.0	1	0.011
1 × 1.5	1	0.7	0.9	4.4 × 5.4	5.3 × 6.6	1.0	1	0.011
6242B								
2 × 1.0	1	0.7	0.9	4.1 × 7.6	5.0 × 9.2	1.0	1	0.011
	2	0.7	0.9	4.2 × 7.8	5.1 × 9.4	1.0	1	0.011
2 × 1.5	1	0.7	0.9	4.4 × 8.1	5.3 × 9.7	1.0	1	0.011
	2	0.7	0.9	4.5 × 8.3	5.4 × 10.0	1.0	1	0.011
2 × 2.5	1	0.7	1.0	4.9 × 9.3	6.0 × 11.2	1.5	1	0.0092
	2	0.7	1.0	5.0 × 9.5	6.1 × 11.4	1.5	1	0.0084
2 × 4.0	2	0.7	1.0	5.5 × 10.4	6.7 × 12.6	1.5	1	0.0070
2 × 6.0	2	0.7	1.1	6.2 × 12.0	7.5 × 14.6	2.5	1	0.0059
2 × 10	2	0.7	1.2	7.3 × 14.5	8.8 × 17.5	4.0	2	0.0047
2 × 16	2	0.7	1.3	8.4 × 17.0	10.1 × 20.5	6.0	2	0.0039
6243B								
3 × 1.0	1	0.7	0.9	4.1 × 10.0	5.0 × 12.1	1.0	1	0.011
3 × 1.5	1	0.7	0.9	4.4 × 10.7	5.3 × 12.9	1.0	1	0.011
3 × 2.5	1	0.7	1.0	4.9 × 12.0	6.0 × 14.6	1.5	1	0.0092
6243B								
3 × 4.0	2	0.7	1.0	5.5 × 14.0	6.7 × 16.9	1.5	1	0.0070
3 × 6.0	2	0.7	1.1	6.2 × 16.2	7.5 × 19.5	2.5	1	0.0059
3 × 10	2	0.7	1.2	7.3 × 19.5	8.8 × 23.6	4.0	2	0.0047
3 × 16	2	0.7	1.3	8.4 × 22.8	10.1 × 27.6	6.0	2	0.0039

Annex A (informative) Coding cross references

This annex has been included to assist users by linking the table references from BS 7211:1998 with the position of these cables either in BS 7211:2012 or in BS EN 50525-3-41; see Table A.1.

Table A.1 UK and harmonized CENELEC coding cross references

Location in BS 7211:1998	New location		UK code	CENELEC code
	Standard	Clause/Table		
Table 3a	BS EN 50525-3-41	4.1	6491B	H07Z – U/R
Table 3b	BS EN 50525-3-41	4.2	6491B	H07Z – K
Table 4a	BS EN 50525-3-41	4.3	2491B	H05Z – U
Table 4b	BS EN 50525-3-41	4.4	2491B	H05Z – K
Table 5	BS 7211:2012	Table 3	6181B	—
Table 6	BS 7211:2012	Table 4	6182B 6183B 6184B 6185B	—
Table 7	BS 7211:2012	Table 5	6241B 6242B 6243B	—

Annex B
(informative)**Traditional UK cables transferred to BS EN 50525**

Cables that have traditionally been included in British Standards, which were also harmonized, have been moved to BS EN 50525 (all parts).

For clarity and openness during this period of change, the cable types that have the most widespread applications in the United Kingdom have been included in this annex to aid understanding; see Table B.1 to Table B.4.

Table B.1 Halogen free, low smoke, conduit cable 450/750 V: formerly in BS 7211

Construction: plain copper rigid conductor, low smoke, halogen free, insulated only, 450/750 V

Traditional UK cable code: 6491B (solid) Harmonized cable code: H07Z-U

Traditional UK cable code: 6491B (rigid strand) Harmonized cable code: H07Z-R

Extracted from BS EN 50525-3-41

Nominal cross-sectional area of conductors mm ²	Class of conductor (BS EN 60228)	Thickness of insulation Specified value mm	Mean overall diameter		Minimum insulation resistance at 90 °C MΩ.km
			Lower limit mm	Upper limit mm	
1.5	1	0.7	2.6	3.3	0.011
1.5	2	0.7	2.7	3.4	0.010
2.5	1	0.8	3.2	4.0	0.010
2.5	2	0.8	3.3	4.1	0.009
4	1	0.8	3.6	4.6	0.0085
4	2	0.8	3.8	4.7	0.0077
6	1	0.8	4.1	5.2	0.0070
6	2	0.8	4.3	5.4	0.0065
10	1	1.0	5.3	6.6	0.0070
10	2	1.0	5.6	7.0	0.0065
16	2	1.0	6.4	8.0	0.0050
25	2	1.2	8.1	10.1	0.0050
35	2	1.2	9.0	11.3	0.0043
50	2	1.4	10.6	13.2	0.0043
70	2	1.4	12.1	15.1	0.0035
95	2	1.6	14.1	17.6	0.0035
120	2	1.6	15.6	19.4	0.0032
150	2	1.8	17.3	21.6	0.0032
185	2	2.0	19.3	24.1	0.0032
240	2	2.2	22.0	27.5	0.0032
300	2	2.4	24.5	30.6	0.0030
400	2	2.6	27.5	34.3	0.0028
500	2	2.8	30.5	38.2	0.0028
630	2	2.8	34.0	42.5	0.0025

Table B.2 Halogen free, low smoke, flexible conduit cable 450/750 V: formerly in BS 7211

Construction: plain copper flexible conductor, low smoke halogen free insulation, 450/750 V

Traditional UK cable code: 6491B
(flexible stranded, for fixed
installations)

Harmonized cable code: H07Z-K

Extracted from BS EN 50525-3-41

Number and nominal cross-sectional area of conductors mm ²	Thickness of insulation Specified value mm	Mean overall dimensions		Minimum insulation resistance at 90 °C MΩ.km
		Lower limit mm	Upper limit mm	
1.5	0.7	2.8	3.5	0.010
2.5	0.8	3.4	4.3	0.009
4	0.8	3.9	4.9	0.007
6	0.8	4.4	5.5	0.006
10	1.0	5.7	7.1	0.0056
16	1.0	6.7	8.4	0.0046
25	1.2	8.4	10.6	0.0044
35	1.2	9.7	12.1	0.0038
50	1.4	11.5	14.4	0.0037
70	1.4	13.2	16.6	0.0032
95	1.6	15.1	18.8	0.0032
120	1.6	16.7	20.9	0.0029
150	1.8	18.6	23.3	0.0029
185	2.0	20.6	25.8	0.0029
240	2.2	23.5	29.4	0.0028

Table B.3 Halogen free, low smoke, conduit cable 300/500 V: formerly in BS 7211

Construction: plain copper rigid conductor, low smoke, halogen free insulation, 300/500 V

Traditional UK cable code: 2491B

Harmonized cable code: H05Z-U

Extracted from BS EN 50525-3-41

Number and nominal cross-sectional area of conductors mm ²	Thickness of insulation Specified value mm	Mean overall dimensions		Minimum insulation resistance at 90 °C MΩ.km
		Lower limit mm	Upper limit mm	
0.5	0.6	1.9	2.4	0.015
0.75	0.6	2.1	2.6	0.012
1.0	0.6	2.2	2.8	0.011

Table B.4 Halogen free low smoke flexible conduit cable 300/500 V: formerly in BS 7211

Construction: plain copper flexible conductor, low smoke halogen free insulation, 300/500 V

Traditional UK cable code: 2491B

Harmonized cable code: H05Z-K

Extracted from BS EN 50525-3-41

Number and nominal cross-sectional area of conductors mm ²	Thickness of insulation Specified value mm	Mean overall dimensions		Minimum insulation resistance at 90 °C MΩ.km
		Lower limit mm	Upper limit mm	
0.5	0.6	2.1	2.6	0.013
0.75	0.6	2.2	2.8	0.011
1.0	0.6	2.4	2.9	0.010

Annex C (informative) Guide to use

COMMENTARY ON Annex C

This annex gives details on general guidance and is not intended as an interpretation of any UK statutory requirements, where these apply.

The cables contained in this British Standard are suitable for locations where low levels of emission of smoke and corrosive gases are required in case of fire or burning.

NOTE 1 Attention is drawn to the Building Regulations 2010, part B volume 1, paragraph B1.iv [1] for details on safe means of escape.

None of the cable types specified in this British Standard are intended to be laid underground.

NOTE 2 Installation requirements and current ratings are detailed in BS 7671.

It is assumed that the design of installations and the specification, purchase and installation of cables specified in this British Standard is entrusted to suitably skilled and competent people.

Information on the specific cables in this British Standard is given in the form of limiting values (see Table C.1) and is illustrated by examples (see Table C.2), which are not exhaustive but which indicate ways by which safety can be obtained.

NOTE 3 BS 7540-1 gives general guidance for the use of cables.

It is not practicable to include here all possible methods of installation that installers or users might adopt. If methods are adopted that are not recommended, then this could result in a reduction of safety and life expectancy of the cable. If the cable is intended to be used outside the recommended use, the cable manufacturer should be consulted for advice.

Table C.1 Constructional details, methods of installation and temperature for Table 3 to Table 5

Parameter		Table 3	Table 4	Table 5
		6181B ^{A)}	6182B ^{A)} 6183B 6184B 6185B	6241B ^{A)} 6242B 6243B
Constructional details:				
Nominal voltage rating	V	450/750	450/750	300/500
Conductor class ^{B)}		1 & 2	1 & 2	1 & 2
Number of cores		1	2 to 5	1 to 3
Cross-sectional area size range	mm ²	1 to 35	1 to 35	1 to 16
Method of installation: ^{C)}				
In conduit		+	+	+
In cable trunking		+	+	+
In cable ducting		+	+	+
Clipped direct		+	+	+
On cable tray		+	+	+
Embedded		+	+	+
Temperature:				
Maximum continuous conductor operating ^{D)}	°C	90	90	90
Maximum conductor short circuit (Maximum allowable time 5 s)	°C	250	250	250
Maximum overload (Maximum allowable time 4 h)	°C	156	156	156
Maximum cable surface ^{E)}	°C	90	90	90
Maximum storage	°C	40	40	40
Minimum installation and handling	°C	5	5	5

NOTE For the relevant parameter "+" indicates acceptable practice.

^{A)} These are UK cable codes.

^{B)} Conductor class designations: 1 = solid wire; 2 = stranded (rigid).

^{C)} The presence of water in contact with the cable is not acceptable.

^{D)} The maximum conductor temperature at which the particular cable should operate depends on the limiting temperature of the other cables and accessories with which it is in contact.

^{E)} See BS 7540-1.

Table C.2 Guide to use

Table	Cable type	Recommendations for use	Comments
Tables 3 and 4	Low smoke cable with single core, 2-core, 3-core, 4-core and 5-core, sheathed overall.	The cables are suitable for: locations where a low level of emission of smoke and corrosive gases are required in case of fire or burning; fixed installation in dry or damp premises; installation in surface-mounted or embedded conduits, or similar closed systems.	For use where special fire performance is necessary or where local conditions or regulations require increased levels of public safety. These cables are not intended to provide circuit integrity in case of fire. The defined tests for smoke and halogen free gases relate only to the cables and not to cable and conduit together.
Table 5	Low smoke cable with single core, flat twin and 3-core, sheathed, with circuit protective conductor.	The cables are suitable for: locations where a low level of emission of smoke and corrosive gases are required in case of fire or burning; fixed installation in dry or damp premises; fixed installation in industrial, commercial and domestic premises; installation in walls, on boards, in conduit, trunking or embedded in plaster.	For use where special fire performance is necessary or where local conditions or regulations require increased levels of public safety. These cables are not intended to provide circuit integrity in case of fire. The defined tests for smoke and halogen free gases relate only to the cables and not to cable and conduit together.

Annex D (normative) Compatibility test

D.1 Principle

This test determines whether the insulation and sheath is likely to deteriorate due to contact with the other components in the cables.

D.2 Procedure

D.2.1 Prepare a test sample by ageing it in an air oven in accordance with BS EN 60811-401, 4.2.3.4, for 7 days at (100 ± 2) °C. Place a sheet of clean white blotting paper under each test sample in the oven during the ageing to detect any exudation that might drip from the cable.

D.2.2 After completion of the ageing test, the tensile strength and elongation at break for the insulation and sheath shall conform to the requirements stated in Table D.1 when measured in accordance with BS EN 60811-501.

Table D.1 Compatibility requirements

Component	Parameter	Requirements for material type			
		GP 8	EI 5	LTS 2	LTS 4
Insulation	Minimum tensile strength (N/mm ²)	12.5	10	—	—
	Minimum percentage elongation at break	200	125	—	—
	Maximum percentage variation ^{A)} of tensile strength	±25	±30	—	—
	Maximum percentage variation ^{A)} of elongation at break	±25	±30	—	—
Sheath	Minimum tensile strength (N/mm ²)	—	—	6	10
	Minimum percentage elongation at break	—	—	100	100
	Maximum percentage variation ^{A)} of tensile strength	—	—	±40	±40
	Maximum percentage variation ^{A)} of elongation at break	—	—	±40	±40

^{A)} The variation is the difference between the respective values obtained prior to and after heat treatment, expressed as a percentage of the former.

Annex E Method of test for voltage withstand (normative)

E.1 Sample

E.1.1 *Sample of completed cable*, not less than 20 m long.

E.2 Procedure

Immerse the sample in water at a temperature of (20 ± 5) °C for a period of not less than 24 h. Ensure that the ends of the cable protrude above the water by a distance sufficient to prevent excessive surface leakage when the test voltage is applied between the conductor and the water.

Take:

- each conductor in turn;
- all other conductors, which are connected together and also connected to the water.

Gradually apply a test voltage of 2 000 V for 300/500 V cable or 2 500 V for 450/750 V cable between a) and b) and maintain at full r.m.s. value for 15 min.

Repeat the test, but applying the voltage between all conductors connected together and the water.

In both cases earth the circuit protective conductor if present but do not include it in the conductors to be tested. While the sample is still immersed, disconnect the circuit protective conductor from the water and apply a voltage of 1 000 V a.c. for 5 min between this and the water.

Annex F (informative)

Notes on type tests

F.1 General

Type tests, after they have been completed, need not be repeated unless changes have been made that might affect conformity to the test requirements. Type tests are not normally required on cables for any individual contracts provided that such type tests have already been successfully performed by the manufacturer.

Subclauses F.2, F.3 and F.4 give guidance as to the amount of type testing that might reasonably be required.

F.2 Sample selection for type tests

For type tests on finished cable, conformity can be confirmed for the complete range of cables in Table 3 to Table 5 by selecting samples for tests as follows:

- a) for single core cables, the smallest and largest conductor size shall be tested;
- b) for multicore cables, the smallest conductor size with the smallest number of cores, and the largest conductor size with the largest number of cores shall be tested.

In addition, where manufacturers want to demonstrate conformity to this British Standard, the cable samples should be subjected to full dimensional checks and to all other sample (S) and routine (R) tests in accordance with Table 2.

F.3 Type tests

F.3.1 Insulation material (see 7.1)

One test should be performed for each grade of insulation material on any one cable from the range of cables selected.

F.3.2 Sheath material (see 11.1)

One test should be performed for each grade of sheath material on any one cable from the range of cables selected.

F.3.3 Corrosive and acid gas test (see Table 2)

As this is a test on a cable component and is therefore generally independent of size or number of cores, only one test is necessary.

F.3.4 Insulation resistance at 90 °C (see 17.2)

One test should be performed on each size of cable selected.

F.3.5 Compatibility test (see 17.4)

One test should be performed on each size of cable selected.

F.3.6 Flame propagation of bunched wires or cables (see 17.5)

To conform to BS EN 60332-3-24:2009, Annex A, two possible methods of installation are stated: in spaced and touching formations. One size of multicore cable having a tabulated diameter not more than 15 mm should therefore be selected and tested in touching formation, and one having a tabulated diameter between 26 mm and 40 mm (providing that at least two samples are used) and tested in spaced formation and should conform to BS EN 60332-3-24:2009, Annex A.

F.3.7 Length of lay (see 16.7)

NOTE This test is classified as a sample test. The guidance given below applies to type testing.

One test should be performed on each size of cable selected.

F.3.8 Shrinkage test on insulation (see 17.6)

One test should be performed on each size of cable selected.

F.4 Change of material

The tests referred to in **F.3** assume that the materials are consistent throughout the range of cables for which conformity is to be confirmed. Where a change occurs, additional testing should be carried out to ensure that such changes are adequately examined.

F.5 Evidence of type testing

When evidence of type testing is required, this should be stated at the enquiry stage. Due to the possible variations in cable designs, it should not be assumed that full type test information is available for the size and type of cable of a particular enquiry.

A certificate of type test signed by the representative of a competent witnessing body, or a properly authorized report by the manufacturer giving the test results, should be acceptable.

Bibliography

Standards publications

For dated references, only the edition cited applies. For undated references, the latest edition of the referenced document (including any amendments) applies.

BS 6004, *Electric cables – PVC insulated and PVC sheathed cables for voltages up to and including 300/500 V, for electric power and lighting*

BS 6360, *Specification for conductors in insulated cables and cords*⁵⁾

BS 6469-99.1, *Insulating and sheathing materials of electric cables – Part 99: Test methods used in the United Kingdom but not specified in BS EN 60811 – Section 99.1: Non-electrical tests*⁶⁾

BS 7540-1, *Electric cables – Guide to use for cables with a rated voltage not exceeding 450/750 V – Part 1: General guidance (Implementation of CENELEC HD 516 S2)*

BS 7655-5.1, *Specification for insulating and sheathing materials for cables – Part 5: Cross-linked insulating compounds having low emission of corrosive gases, and suitable for use in cables having low emission of smoke when affected by fire – Section 5.1: Harmonized cross-linked types*⁷⁾

BS 7671, *Requirements for electrical installations – IET Wiring Regulations – Seventeenth edition*

BS EN 50265-2-1, *Common test methods for cables under fire conditions – Test for resistance for vertical flame propagation for a single insulated conductor or cable – Part 2-1: Procedures – 1 kW pre-mixed flame*⁸⁾

BS EN 50266-2-4, *Common test methods for cables under fire conditions – Test for vertical flame spread of vertically-mouthed bunched wires or cables – Part 2-4: Procedures – Category C*⁹⁾

BS EN 50268-2, *Common test methods for cables under fire conditions – Measurement of smoke density of cables burning under defined conditions – Part 2: Procedure*¹⁰⁾

BS EN 50356, *Method for spark testing of cables*¹¹⁾

BS EN 50525-3-41, *Electric cables – Low voltage energy cables of rated voltages up to and including 450/750 V(U₀/U) – Part 3-41: Cables with special fire performance – Single core non-sheathed cables with halogen-free crosslinked insulation, and low emission of smoke*

HD 21 (all parts), *Cables of rated voltages up to and including 450/750 V and having thermoplastic insulation*

HD 22 (all parts), *Cables of rated voltages up to and including 450/750 V and having cross-linked insulation*

⁵⁾ This is referred to in the Foreword only. BS 6360 has been withdrawn and replaced by BS EN 60228.

⁶⁾ This is referred to in the Foreword only.

⁷⁾ This is referred to in the Foreword only. BS 7655-5.1 has been withdrawn and replaced by BS EN 50363-5.

⁸⁾ This is referred to in the Foreword only. BS 50265-2-1 has been withdrawn and replaced by BS EN 60332-1-2.

⁹⁾ This is referred to in the Foreword only. BS EN 50266-2-4 has been withdrawn and replaced by BS EN 60332-3-24.

¹⁰⁾ This is referred to in the Foreword only. BS EN 50268 has been withdrawn and replaced by BS EN 61034.

¹¹⁾ This is referred to in the Foreword only. BS EN 50356 has been withdrawn and replaced by BS EN 62230.

HD 308 S2, *Identification of cores in cables and flexible cords*

Other publications

- [1] GREAT BRITAIN. The Building Regulations 2010, as amended. SI No. 2214.
London: The Stationery Office.

British Standards Institution (BSI)

BSI is the independent national body responsible for preparing British Standards and other standards-related publications, information and services. It presents the UK view on standards in Europe and at the international level.

BSI is incorporated by Royal Charter. British Standards and other standardisation products are published by BSI Standards Limited.

Revisions

British Standards and PASs are periodically updated by amendment or revision. Users of British Standards and PASs should make sure that they possess the latest amendments or editions.

It is the constant aim of BSI to improve the quality of our products and services. We would be grateful if anyone finding an inaccuracy or ambiguity while using British Standards would inform the Secretary of the technical committee responsible, the identity of which can be found on the inside front cover. Similar for PASs, please notify BSI Customer Services.

Tel: +44 (0)20 8996 9001 Fax: +44 (0)20 8996 7001

BSI offers BSI Subscribing Members an individual updating service called PLUS which ensures that subscribers automatically receive the latest editions of British Standards and PASs.

Tel: +44 (0)20 8996 7669 Fax: +44 (0)20 8996 7001

Email: plus@bsigroup.com

Buying standards

You may buy PDF and hard copy versions of standards directly using a credit card from the BSI Shop on the website www.bsigroup.com/shop. In addition all orders for BSI, international and foreign standards publications can be addressed to BSI Customer Services.

Tel: +44 (0)20 8996 9001 Fax: +44 (0)20 8996 7001

Email: orders@bsigroup.com

In response to orders for international standards, BSI will supply the British Standard implementation of the relevant international standard, unless otherwise requested.

Information on standards

BSI provides a wide range of information on national, European and international standards through its Knowledge Centre.

Tel: +44 (0)20 8996 7004 Fax: +44 (0)20 8996 7005

Email: knowledgecentre@bsigroup.com

BSI Subscribing Members are kept up to date with standards developments and receive substantial discounts on the purchase price of standards. For details of these and other benefits contact Membership Administration.

Tel: +44 (0)20 8996 7002 Fax: +44 (0)20 8996 7001

Email: membership@bsigroup.com

Information regarding online access to British Standards and PASs via British Standards Online can be found at www.bsigroup.com/BSOL

Further information about British Standards is available on the BSI website at www.bsi-group.com/standards

Copyright

All the data, software and documentation set out in all British Standards and other BSI publications are the property of and copyrighted by BSI, or some person or entity that own copyright in the information used (such as the international standardisation bodies) has formally licensed such information to BSI for commercial publication and use. Except as permitted under the Copyright, Designs and Patents Act 1988 no extract may be reproduced, stored in a retrieval system or transmitted in any form or by any means – electronic, photocopying, recording or otherwise – without prior written permission from BSI. This does not preclude the free use, in the course of implementing the standard, of necessary details such as symbols, and size, type or grade designations. If these details are to be used for any other purpose than implementation then the prior written permission of BSI must be obtained. Details and advice can be obtained from the Copyright & Licensing Department.

Tel: +44 (0)20 8996 7070

Email: copyright@bsigroup.com

BSI

389 Chiswick High Road London W4 4AL UK

Tel +44 (0)20 8996 9001

Fax +44 (0)20 8996 7001

www.bsigroup.com/standards