

Guide to

**Construction and use
of 130 mm (5.25 in)
flexible disk cartridges
for data interchange
using modified
frequency modulation
recording
at 7958 ftprad, 3.8 tpmm
(96 tpi) on both sides —**

**Part 1: Dimensional, physical and
magnetic characteristics**

[ISO title: Information processing — Data interchange
on 130 mm (5.25 in) flexible disk cartridges using modified
frequency modulation recording at 7 958 ftprad, 3,8 tpmm (96 tpi),
on both sides — Part 1: Dimensional, physical and magnetic
characteristics]

The European Standard EN 28378-1:1989 has the status of a
British Standard

UDC 681.327.634:002.2:004.14

Committees responsible for this British Standard

The preparation of this British Standard was entrusted by the Information Systems Technology Standards Committee (IST/-) to Technical Committee IST/4, upon which the following bodies were represented:

Association for Payment Clearing Services
 British Computer Society
 British Telecommunications plc
 Business Equipment and Information Technology Association
 Department of Trade and Industry (National Physical Laboratory)
 HM Customs and Excise
 HM Treasury (Central Computer and Telecommunications Agency)
 Institute of Administrative Management
 Institute of Quality Assurance
 Institution of Electrical Engineers
 Institution of Electronic and Radio Engineers
 Institution of Mechanical Engineers
 National Computing Centre Ltd.
 Post Office

This British Standard, having been prepared under the direction of the Information Systems Technology Standards Committee, was published under the authority of the Board of BSI and comes into effect on 28 February 1989

© BSI 12-1999

The following BSI references relate to the work on this standard:
 Committee reference IST/4
 Draft for comment 88/60280 DC

ISBN 0 580 16914 6

Amendments issued since publication

Amd. No.	Date of issue	Comments
7042	February 1992	Indicated by a sideline in the margin

Contents

	Page
Committees responsible	Inside front cover
National foreword	ii
<hr/>	
Brief history	2
0 Introduction	3
1 Scope and field of application	3
2 Conformance	3
3 References	3
4 Definitions	3
5 General description	4
6 General requirements	4
7 Dimensional characteristics	5
8 Physical characteristics	7
9 Magnetic characteristics	7
10 Bibliography	9
<hr/>	
Annex A Measurement of the cartridge thickness	14
Annex B Measurement of light transmittance	16
Annex C Method for measuring the effective track width	19
Annex D Use of hub support rings	19
<hr/>	
Figure 1 — Flexible disk cartridge	9
Figure 2 — Section A-A	10
Figure 3 — Protective envelope with cartridge	10
Figure 4 — Jacket dimensions	11
Figure 5 — Cartridge thickness	12
Figure 6 — Disk dimensions	12
Figure 7 — Disk thickness	12
Figure 8 — Pressure pad area	13
Figure 9 — Measuring gauge	14
Figure 10 — Measuring gauge	15
Figure 11 — Stylus	15
Figure 12 — Measuring device	18
Figure 13 — Electronic circuitry	18
Figure 14 — Track width	19
<hr/>	
Publications referred to	Inside back cover
<hr/>	

National foreword

This Part of BS 7023, prepared under the direction of the Information Systems Technology Standards Committee, is identical with ISO 8378-1:1986 “*Information processing — Data interchange on 130 mm (5.25 in) flexible disk cartridges using modified frequency modulation recording at 7 958 ftprad, 3,8 tpmm (96 tpi), on both sides — Part 1: Dimensional, physical and magnetic characteristics*” published by the International Organization for Standardization (ISO).

In 1989 the European Committee for Standardization (CEN) accepted ISO 8378-1 as European Standard EN 28378-1:1989.

The purpose of this standard is to define those characteristics necessary for successful data interchange using flexible disk cartridges. The information contained is intended as a guide to writing complete specifications for manufacture, purchasing and/or testing. The text of the International Standard does not accord with the recommendations for drafting product specifications given in the ISO Directives, or in BS 0-3, but the BSI Technical Committee considers the text is useful as a guide when cartridges are being described or specified. For this reason this Part of BS 7023 has a different title from the International Standard; it is issued as a British Standard guide and it should only be used as such. It should not be used on its own as a British Standard product specification and, in particular, no claims of compliance with this Part of BS 7023 should be made.

Terminology and conventions. The text of the International Standard has been approved as suitable for publication as a British Standard without deviation. Some terminology and certain conventions are not identical with those used in British Standards; attention is drawn especially to the following.

For metric units the comma has been used as a decimal marker. In British Standards it is current practice to use a full point on the baseline as the decimal marker.

Wherever the words “part of ISO 8378” and “ISO 8378” appear, referring to this standard, they should be read as “Part of BS 7023” and “BS 7023” respectively.

Cross-references

International Standard	Corresponding British Standard
ISO 7665:1983	BS 6542 <i>File structure and labelling of flexible disk cartridge for information interchange</i> Part 1:1984 <i>Specification for sequential file allocation structure</i> (Identical)
	BS 7023 <i>Guide to construction and use of 130 mm (5.25 in) flexible disk cartridges for data interchange, using modified frequency modulation recording at 7 958 ftprad, 3,8 tpmm (96 tpi) on both sides</i>
ISO 8378-2:1986	Part 2:1988 <i>Track format A</i> (Identical)
ISO 8378-3:1986	Part 3:1988 <i>Track format B</i> (Identical)

The Technical Committee has reviewed the provisions of ISO 9293, to which reference is made in the text, and has decided that they are acceptable for use in conjunction with this standard.

A British Standard does not purport to include all the necessary provisions of a contract. Users of British Standards are responsible for their correct application.

Compliance with a British Standard does not of itself confer immunity from legal obligations.

Summary of pages

This document comprises a front cover, an inside front cover, pages i to iv, the EN title page, pages 2 to 20, an inside back cover and a back cover.

This standard has been updated (see copyright date) and may have had amendments incorporated. This will be indicated in the amendment table on the inside front cover.

UDC 681.327.634

Descriptors: Data processing, information interchange, flexible disk cartridges, magnetic recording, frequency modulation, dimensions, physical properties, magnetic properties

English version

Information processing. Data interchange
on 130 mm (5,25 in) flexible disk cartridges using
modified frequency modulation recording
at 7 958 ftprad, 3,8 tpmm (96 tpi), on both sides.
Part 1: Dimensional, physical and magnetic characteristics

(ISO 8378-1, 1st edition, 1986)

Traitement de l'information. Echange de données sur cartouches à disquette de 130 mm (5,25 in) utilisant un enregistrement à modulation de fréquence modifiée à 7 958 ftprad, 3,8 tpmm (96 tpi), sur deux faces.
Partie 1: Caractéristiques dimensionnelles, physiques et magnétiques
(ISO 8378-1, 1ère édition, 1986)

Informationsverarbeitung. Datenaustausch auf 130 mm (5,25 in) Disketten mittels modifizierter Frequenzmodulationsaufzeichnung bei 7 958 ftprad, 3,8 tpmm (96 tpi), auf beiden Seiten. Teil 1: Mechanische physikalische und Grössenanforderungen
(ISO 8378-1, 1 Ausgabe, 1986)

This European Standard was approved by CEN on 1988-12-21. CEN members are bound to comply with the CEN/CENELEC Internal Regulations which stipulate the conditions for giving this European Standard the status of a national standard without any alteration.

Up-to-date lists and bibliographical references concerning such national standards may be obtained on application to the Central Secretariat or to any CEN member.

This European Standard exists in three official versions (English, French, German). A version in any other language made by translation under the responsibility of a CEN member into its own language and notified to the Central Secretariat has the same status as the official versions.

CEN members are the national standards bodies of Austria, Belgium, Denmark, Finland, France, Germany, Greece, Iceland, Ireland, Italy, Luxembourg, Netherlands, Norway, Portugal, Spain, Sweden, Switzerland and United Kingdom.

CEN

European Committee for Standardization
Comité Européen de Normalisation
Europäisches Komitee für Normung

Central Secretariat: rue de Stassart 36, B-1050 Brussels

Brief history

The Technical Board has decided to submit the International Standard

ISO 8378-1, 1st edition 1986 *“Information processing; Data interchange on 130 mm (5,25 in) flexible disk cartridges using modified frequency modulation recording at 7 958 ftprad, 3,8 tpmm (96 tpi) on both sides; Part 1: Dimensional, physical and magnetic characteristics”*

to the formal vote. The result of this vote was positive.

For the time being, this document exists only in the English and the French versions.

According to the CEN/CENELEC Common Rules, the following countries are bound to implement this standard: Austria, Belgium, Denmark, Finland, France, Germany, Greece, Iceland, Ireland, Italy, Luxembourg, Netherlands, Norway, Portugal, Spain, Sweden, Switzerland and United Kingdom.

Statement

The text of the International Standard ISO 8378-1, 1st edition, 1986, was approved by CEN as a European Standard without any modification.

0 Introduction

ISO 8378 specifies the characteristics of 130 mm (5.25 in) flexible disk cartridges recorded at 7 958 ftprad, 3,8 tpmm (96 tpi), using modified frequency modulation (MFM) recording on 80 tracks on each side.

ISO 8378-2 and ISO 8378-3 each specify the quality of recorded signals, the track layout, and a track format to be used on 130 mm (5.25 in) flexible disk cartridges, intended for data interchange between data processing systems.

ISO 8378-1 and ISO 8378-2, together with the labelling scheme specified in ISO 7665, provide for full data interchange between data processing systems.

ISO 8378-1 and ISO 8378-3, together with the labelling scheme specified in ISO 9293, provide for full data interchange between data processing systems.

1 Scope and field of application

This part of ISO 8378 specifies the dimensional, physical and magnetic characteristics of the cartridge so as to provide physical interchangeability between data processing systems.

NOTE Numeric values in the SI and/or Imperial measurement system in this part of ISO 8378 may have been rounded off and therefore are consistent with, but not exactly equal to, each other. Either system may be used, but the two should be neither intermixed nor re-converted. The original design was made using Imperial units and further developments were made using SI units.

2 Conformance

A flexible disk cartridge shall be in conformance with ISO 8378 when it meets all the requirements of this part of ISO 8378 and all those of either ISO 8378-2 or ISO 8378-3.

3 References

ISO 7665, *Information processing — File structure and labelling of flexible disk cartridges for information interchange.*

ISO 8378, *Information processing — Data interchange on 130 mm (5.25 in) flexible disk cartridges using modified frequency modulation recording at 7 958 ftprad, 3,8 tpmm (96 tpi), on both sides —*

— *Part 2: Track format A;*

— *Part 3: Track format B.*

ISO 9293, *Information processing — Volume and file structure of flexible disk cartridges for information interchange.*

4 Definitions

For the purpose of this part of ISO 8378 the following definitions apply.

4.1

flexible disk

a flexible disk which accepts and retains on the specified side or sides magnetic signals intended for input/output and storage purposes of information data processing and associated systems

4.2

reference flexible disk cartridge

a flexible disk cartridge arbitrarily selected for a given property for calibrating purposes

4.3

secondary reference flexible disk cartridge

a flexible disk cartridge intended for routine calibrating purposes, the performance of which is known and stated in relation to that of the reference flexible disk cartridge

4.4

signal amplitude reference flexible disk cartridge

a reference flexible disk cartridge selected as a standard for recording field and signal amplitude

NOTE A master standard for signal amplitudes, reference fields, overwrite and resolution characteristics has been established by the Physikalisch-Technische Bundesanstalt (PTB) Bundesallee 100 in Braunschweig, Germany, F.R. Secondary reference flexible disk cartridges can be ordered from PTB Lab 1.41 under part number RM 7487 as long as available.

4.5

typical field (for each side)

the minimum recording field, which, when applied to a flexible disk cartridge, causes a signal output equal to 95 % of the maximum average signal amplitude when taken as a function of the recording field at the specified track and flux transition frequency of that flexible disk cartridge

4.6

reference field

the typical field of the signal amplitude reference flexible disk cartridge

4.7

test recording current (for each side)

the current between 145 % and 155 % of the current which produces the reference field at 125 000 flux transitions per second (ftps) on track 00 on both sides

4.8 standard reference amplitude (SRA) (for each side)

the average signal amplitudes derived from the reference tracks on the signal amplitude reference flexible disk cartridge using the appropriate test recording current

SRA_{1f} is the average signal amplitude from a recording written using 125 000 ftps

SRA_{2f} is the average signal amplitude from a recording written using 250 000 ftps

4.9 average signal amplitude

the arithmetically averaged value for a track of the output voltages measured peak-to-peak over the whole track

4.10 in-contact

an operating condition in which the magnetic surface of the disk intended for data storage is in physical contact with the magnetic heads

4.11 formatting

writing the proper control information, establishing the physical tracks, and designating the addresses of physical records on the flexible disk's surfaces

4.12 initialization

writing the volume label, the ERMAP label and other information initially required to be on the flexible disk cartridge prior to the commencement of general processing or use

4.13 recording area

that area of each disk surface with which the head may come into contact

5 General description

5.1 General figures

A typical flexible disk cartridge is represented in Figure 1 to Figure 3 as follows:

Figure 1 — Flexible disk cartridge, shows the cartridge seen from above, side 0 up.

Figure 2 — Section A-A, is a cross-section along line A-A in Figure 1.

Figure 3 — Protective envelope with cartridge, shows a protective envelope with cartridge, side 1 up.

5.2 Main elements

The main elements of this flexible disk cartridge are

- the recording disk;
- the liner;
- the jacket.

The cartridge is stored in an envelope.

5.3 Description

The jacket is of a square form. It includes a central window, an index window and a head window in both sides.

The liner is fixed to the inside of the jacket. It comprises two layers of material between which the disk is held. The liner has the same openings as the jacket.

The disk has only a central and an index window.

5.4 Optional features

The interchange characteristics of the jacket allow for variations of its construction as follows:

- a) the jacket may include flaps (for example three flaps as shown in the diagram, or more);
- b) the jacket may include notches along the reference edge;
- c) the centre of the disk may be reinforced by hub support rings (see Annex D).

6 General requirements

6.1 Environment and transportation

6.1.1 Testing environment

Tests and measurements made on the cartridge to check the requirements of ISO 8378 shall be carried out under the following conditions:

- temperature: 23 ± 2 °C (73 ± 4 °F);
- relative humidity: 40 to 60 %;
- conditioning before testing: 24 h minimum.

The temperature and the relative humidity shall be measured in the air immediately surrounding the cartridge.

The stray magnetic field at any point on the disk surface, including that resulting from the concentrating effect of the recording head, shall not exceed 4 000 A/m (50 Oe).

6.1.2 Operating environment

Cartridges used for data interchange shall be operated under the following conditions:

- temperature: 10 to 51,5 °C (50 to 125 °F);
- relative humidity: 20 to 80 %;
- wet-bulb temperature: less than 29 °C (84 °F).

The temperature and the relative humidity shall be measured in the air immediately surrounding the cartridge. It is recommended that the rate of change of the temperature should not exceed 20 °C (36 °F) per hour.

For reliable interchange, it is recommended that the temperature and relative humidity conditions when reading are not at the opposite extremes to the conditions when writing.

There shall be no deposit of moisture on or in the cartridge.

The stray magnetic field at any point on the disk surface, including that resulting from the concentrating effect of the recording head, shall not exceed 4 000 A/m (50 Oe).

6.1.3 Storage environment

During storage the cartridges shall be kept under the following conditions:

- temperature: 4 to 51,5 °C (40 to 125 °F);
- relative humidity: 8 to 80 %.

Each cartridge shall be in an envelope and in an upright position.

There shall be no deposit of moisture on or in the cartridge.

The ambient stray magnetic field at any point on the disk surface shall not exceed 4 000 A/m (50 Oe).

NOTE Cartridges which have been stored at temperatures and humidities outside the operating conditions may exhibit degraded performance characteristics. Such cartridges should be subjected to a conditioning period of not less than 24 h within the operating environment prior to use.

6.1.4 Transportation

Responsibility for ensuring that adequate precautions are taken during transportation shall be with the sender. During transportation the cartridge shall be in its envelope and in a protective package. The latter shall be free from dust or extraneous matter. It shall have a clean interior and a construction to minimize ingress of dust and moisture. It is recommended that a sufficient space exists between cartridge and outer surface of the final container so that risk of damage due to stray magnetic fields will be negligible.

It is recommended that the following conditions are not exceeded:

- temperature: – 40 to 51,5 °C (– 40 to 125 °F);
- maximum rate of temperature change: 20 °C (36 °F) per hour;
- relative humidity: 8 to 90 %.

There should be no deposit of moisture on or in the cartridge.

6.1.5 Handling

The cartridge shall stay out of its envelope for the shortest time possible. When handling the cartridge the operator shall not touch the exposed magnetic surfaces of the disk and shall avoid exposing the cartridge to direct sunlight, moisture and dust.

6.2 Materials

6.2.1 Jacket

The jacket may be constructed from any suitable material.

6.2.2 Liner

The material of the liner shall be able to retain dust without damage to the disk.

6.2.3 Disk

The disk may be constructed from any suitable material (for example bi-axially oriented polyethylene terephthalate) coated on both sides with a strong and flexible layer of magnetic material (for example γ -Fe₂O₃).

6.2.4 Envelope

The envelope may be manufactured from any suitable material (for example paper).

6.3 Direction of rotation

The direction of rotation shall be counterclockwise when looking at side 0.

7 Dimensional characteristics

The dimensional characteristics listed in the following clauses are indicated in Figure 4 to Figure 7.

Figure 4 — Jacket dimensions, shows the jacket.

Figure 5 — Cartridge thickness, shows a partial cross-section of the jacket.

Figure 6 — Disk dimensions, shows the disk.

Figure 7 — Disk thickness, shows a cross-section of the disk.

All dimensions are referred to the reference edge of the cartridge (see Figure 4).

7.1 Jacket

7.1.1 Form

The jacket shall have a square form with angles of 90° ± 30', and a side length

$$l_1 = 133,3 \pm 0,4 \text{ mm (5.250} \pm 0.015 \text{ in)}$$

7.1.2 Thickness

7.1.2.1 Jacket wall and liner

In an area defined by

$$r_1 = 35 \text{ mm (1.38 in)}$$

$$r_2 = 50 \text{ mm (1.97 in)}$$

and with a probe having a diameter of 15 mm (0.59 in) applied against the cartridge with a force of 1 N (3.6 ozf), the thickness of the jacket wall and liner shall be

$$e_1 = 0,45 \pm 0,15 \text{ mm (0.018} \pm 0.006 \text{ in)}$$

7.1.2.2 Cartridge

The overall thickness of the cartridge shall be (see 7.1.7)

1,2 mm (0.047 in) $< e_2 < 2,1$ mm (0.083 in), when measured according to clauses A.1 and A.2 of Annex A.

The cartridge shall fall freely through a gauge with a 2,6 mm (0.10 in) wide opening having flat, vertical walls and depth of 150 mm (5.90 in).

7.1.3 Central windows

The central windows shall have a diameter

$$d_1 = 39,7 \pm 0,2 \text{ mm (1.563} \pm 0.008 \text{ in)}$$

The position of their centre is defined by

$$l_2 = 66,65 \pm 0,30 \text{ mm (2.624} \pm 0.012 \text{ in)}$$

7.1.4 Index windows

7.1.4.1 Location

The centre of the index windows shall be defined by

$$l_3 = 42,10 \pm 0,25 \text{ mm (1.657} \pm 0.010 \text{ in)}$$

$$l_4 = 60,00 \pm 0,25 \text{ mm (2.362} \pm 0.010 \text{ in)}$$

7.1.4.2 Diameter

The diameter of the index windows shall be

$$d_2 = 6,35 \pm 0,20 \text{ mm (0.250} \pm 0.008 \text{ in)}$$

7.1.5 Head windows

7.1.5.1 Location

The location of the lowest point of the head windows shall be defined by

$$l_5 = 3,30 \pm 0,25 \text{ mm (0.130} \pm 0.010 \text{ in)}$$

7.1.5.2 Dimensions

The width of the head windows shall be

$$l_6 = 12,7 \pm 0,2 \text{ mm (0.500} \pm 0.008 \text{ in)}$$

The nominal radius of their ends shall be

$$r_3 = 6,35 \text{ mm (0.250 in)}$$

Their length shall be

$$l_7 = 35,00 \pm 0,25 \text{ mm (1.378} \pm 0.010 \text{ in)}$$

7.1.6 Reference edge profile

Within an area defined by

$$l_8 = 25 \text{ mm (1.0 in)}$$

the reference edge shall have a convex profile, for example be rounded off with one or more radii of 0,3 mm min. (0.012 in min.).

7.1.7 Construction of the jacket

If the jacket utilises flaps, their width shall not exceed

$$l_9 = 12 \text{ mm (0.47 in)}$$

The total thickness e_2 of the cartridge with flaps shall satisfy the conditions of 7.1.2.2 (see Annex A).

7.1.8 Notches

Two notches may be provided along the reference edge. If provided, they shall be entirely contained within areas defined by

$$l_{10} = 48 \text{ mm min. (1.889 in min.)}$$

$$l_{11} = 58 \text{ mm max. (2.283 in max.)}$$

$$l_{12} = 75 \text{ mm min. (2.953 in min.)}$$

$$l_{13} = 85,5 \text{ mm max. (3.366 in max.)}$$

$$l_{14} = 2,0 \text{ mm max. (0.078 in max.)}$$

7.1.9 Write-enable notch

The position and size of the write-enable notch shall be defined by

$$l_{19} = 96,5 \pm 0,2 \text{ mm (3.799} \pm 0.008 \text{ in)}$$

$$l_{20} = 6,35 \pm 0,13 \text{ mm (0.250} \pm 0.005 \text{ in)}$$

$$l_{21} = 3,8 \pm 0,2 \text{ mm (0.150} \pm 0.008 \text{ in)}$$

Writing is inhibited by covering the notch with a material of sufficient stiffness and/or opacity.

7.2 Liner

The liner shall always cover the recording area (7.3.4). However, no part of the liner shall protrude by more than 0,5 mm (0.019 in) into the openings of the jacket.

7.3 Disk

7.3.1 Diameter

The external diameter of the disk shall be

$$d_3 = 130,2 \pm 0,2 \text{ mm (5.125} \pm 0.008 \text{ in)}$$

The inner diameter of the disk shall be

$$d_4 = 28,575 \pm 0,025 \text{ mm (1.125} \pm 0.001 \text{ in)}$$

7.3.2 Thickness

The thickness of the disk shall be

$$e_3 = 0,080 \pm 0,010 \text{ mm (0.003} \pm 0.000 \text{ 4 in)}$$

not including hub supports rings, if fitted.

7.3.3 Index window

7.3.3.1 Location

The location of the index window shall be defined by

$$r_4 = 25,4 \pm 0,1 \text{ mm (1.000} \pm 0.004 \text{ in)}$$

7.3.3.2 Diameter

The diameter of the index window shall be

$$d_5 = 2,54 \pm 0,10 \text{ mm (0.100} \pm 0.004 \text{ in)}$$

7.3.4 Recording area

The recording area shall be defined, on both sides, by

$$r_5 = 31,3 \text{ mm max. (1.23 in max.)}$$

$$r_6 = 62,5 \text{ mm min. (2.46 in min.)}$$

7.3.5 Sides

For convenience of description, the two sides are defined as side 0 and side 1; they are shown in Figure 1 to Figure 4 and Figure 8.

8 Physical characteristics

8.1 Flammability

The cartridge shall be made from materials that, if ignited from a match flame, do not continue to burn in a still carbon dioxide atmosphere.

8.2 Coefficient of linear thermal expansion of the disk

The coefficient of thermal expansion of the disk shall be

$$(17 \pm 8) \times 10^{-6} \text{ K}^{-1}$$

8.3 Coefficient of linear hygroscopic expansion of the disk

The coefficient of hygroscopic expansion of the disk shall be

$$(0 \text{ to } 15) \times 10^{-6} \text{ per percent of relative humidity}$$

8.4 Opacity

8.4.1 Opacity of the jacket

The jacket shall have a light transmittance of less than 1 % using an LED with a nominal wavelength of $940 \pm 10 \text{ nm}$ as the radiation source when measured according to Annex B.

8.4.2 Opacity of the disk

The disk shall have a light transmittance of less than 1 % using an LED with a nominal wavelength of $940 \pm 10 \text{ nm}$ as the radiation source when measured according to Annex B.

8.5 Torque

8.5.1 Starting torque

The starting torque, without heads and pad(s) loaded to the cartridge, shall not exceed $0,01 \text{ N m}$ (1.42 ozf in).

8.5.2 Running torque

When the disk cartridge is tested at a rotational speed of $300 \pm 6 \text{ r/min}$, with a pressure pad of $280 \pm 10 \text{ mm}^2$ ($0.434 \pm 0.015 \text{ in}^2$) surface applied with a force of $0,70 \pm 0,05 \text{ N}$ ($2.52 \pm 0.18 \text{ ozf}$) and located parallel to the head windows as defined in Figure 8 by

$$l_{15} = 44 \text{ mm (1.72 in)}$$

$$l_{16} = 55 \text{ mm (2.16 in)}$$

$$l_{17} = 7 \text{ mm (0.28 in)}$$

$$l_{18} = 35 \text{ mm (1.38 in)}$$

the torque necessary to rotate the disk shall not exceed $0,03 \text{ N m}$ (4.26 ozf in).

9 Magnetic characteristics¹⁾

9.1 Track geometry

9.1.1 Number of tracks

There shall be 80 discrete concentric tracks on each side of the disk in the recording area (7.3.4) for data interchange.

9.1.2 Width of tracks

The recorded track width on the disk surface shall be

$$0,159 \text{ 0} \pm 0,006 \text{ 3 mm (0.006 25} \pm 0.000 \text{ 25 in)}$$

The area between the tracks shall be erased. The method of measuring effective track width is given in Annex C.

¹⁾ The peak of each voltage pulse generated at the read head defines the position of each magnetic flux transition. If two adjacent flux transitions are relatively far apart, then the two voltage signals (one positive and one negative) will not overlap. As the distance between flux transitions decreases, the two voltage signals begin to overlap and to subtract from each other, causing a reduction in signal amplitude and a shift in the positions of the voltage signal peaks. This latter phenomenon is referred to as "peak shift". A test method for measuring that portion of the peak shift that is attributable to the flexible cartridge is not presently available but continues to be investigated.

9.1.3 Track location

9.1.3.1 Nominal locations

The nominal radius of the centrelines of all tracks shall be calculated by using the formula

$$R_n = X - \frac{n}{96} \times 25,4 \text{ mm}$$

$$(R_n = X - \frac{n}{96} \text{ in})$$

where

n is the track number: $n = 00$ to 79 ;

$X = 57,150$ mm for side 0 (2.250 0 in);

$X = 55,033$ mm for side one (2.166 7 in).

Therefore, each track on side 1 is offset inwards by eight track positions from the track on side 0 having the same track number.

9.1.3.2 Track location tolerance

For testing purposes, the centrelines of the recorded tracks shall be within $\pm 0,025$ mm (± 0.001 in) of the nominal positions, when measured in the testing environment (see 6.1.1).

9.1.4 Track number

The track number shall be a two-digit decimal number (00 to 79 for each side) which identifies the tracks consecutively, starting at the outermost track (00).

9.1.5 Index

The index signal shall only be used for timing purposes. The index is the point which determines the beginning and the end of the track. At the instant of having detected the leading edge of the index hole, the index is under the read-write gap.

9.2 Functional testing

For the purpose of the following tests the same drive unit shall be used for writing and reading operations.

The in-contact operating condition shall be used.

9.2.1 Surface tests

The magnetic properties of both data surfaces are defined by the testing requirements given below.

9.2.1.1 Test conditions

The disk shall be tested at 300 ± 6 r/min. The test frequencies [flux transitions per second (ftps)] used shall be

$$1f = 125\,000 \pm 125 \text{ ftps}$$

$$2f = 250\,000 \pm 250 \text{ ftps}$$

The frequency(ies) to be used shall be specified for each test.

These measurements are performed on tracks 78 because their positions correspond to the certified areas of RM 7487 (see the note to 4.4).

9.2.1.2 Typical field

The typical field of the disk under test shall be within ± 20 % of the reference field. It shall be measured using $1f$ on track 00 on each side.

9.2.1.3 Average signal amplitude

When the disk under test has been recorded with the test recording current, then read back and compared with the signal amplitude reference flexible disk cartridge recorded under the same conditions, and on the same system, the average signal amplitude shall be

side 0, track 00, using $1f$: less than 130 % of SRA_{1f} for side 0;

side 0, track 78, using $2f$: more than 80 % of SRA_{2f} for side 0;

side 1, track 00, using $1f$: less than 130 % of SRA_{1f} for side 1;

side 1, track 78, using $2f$: more than 80 % of SRA_{2f} for side 1.

9.2.1.4 Resolution

For each side record on track 78, using the test recording current for that side, the ratio

$$\frac{\text{Average signal amplitude using } 2f}{\text{Average signal amplitude using } 1f}$$

shall be greater than 90 % of the value of the same ratio for the equivalent side of the signal amplitude reference flexible disk cartridge.

9.2.1.5 Overwrite

On track 00 of each side, after recording with the appropriate test recording current, first using $1f$ and then overwriting with $2f$ for one revolution, the ratio

$$\frac{\text{Residual average signal amplitude at } 1f \text{ after overwrite using } 2f}{\text{Average signal amplitude after first recording using } 1f}$$

shall be less than 100 % of the value of the same ratio for the signal amplitude reference flexible disk cartridge. This test shall be performed on both sides with a frequency-selective voltmeter.

9.2.1.6 Modulation

Modulation shall be

$$\frac{\text{Maximum mean} - \text{Minimum mean}}{\text{Maximum mean} + \text{Minimum mean}} \times 100 \%$$

The maximum mean shall be the average value of the amplitude modulated output voltage in that part of the track with the maximum amplitudes, and the minimum mean shall be that in the respective part with the minimum amplitudes. Output voltage shall be measured peak-to-peak; averaging shall be done over about 2 000 consecutive flux transitions.

On both sides, on track 00 using $1f$ and on track 78 using $2f$, modulation shall be less than 10 %.

9.2.2 Track quality tests

These tests apply to all usable tracks at the defined positions on each side. The test recording current shall be used.

9.2.2.1 Missing pulse

Write a track at $2f$ with the appropriate test recording current. Any playback signal, when measured base-to-peak, which is less than 40 % of half the arithmetically averaged value of the output voltages measured peak-to-peak over the preceding 2 000 consecutive flux transitions, shall be a missing pulse.

9.2.2.2 Extra pulse

Write a track at $2f$ with the appropriate test recording current. Erase for one revolution with a constant direct current equivalent to the quiescent value of this test recording current.

Any playback signal which, when measured base-to-peak, including the statistical noise and the residual signal of the disk, exceeds 20 % of half the average signal amplitude at $2f$ of the track under test, shall be an extra pulse.

9.2.3 Rejection criteria

9.2.3.1 Defective track

A track on which one or more missing and/or extra pulses are detected in the same position(s) on consecutive passes shall be a defective track. The applicable number of consecutive passes shall be a matter for agreement between the interested parties.

9.2.3.2 Requirements for tracks

As initially received from the medium supplier, the cartridge shall have no defective tracks.

9.2.3.3 Rejected cartridge

A cartridge which does not meet the requirements of 9.2.3.2 shall be rejected.

10 Bibliography

ISO 646, *Information processing — ISO 7-bit coded character set for information processing interchange*.

ISO 2022, *Information processing — ISO 7-bit and 8-bit coded character set — Code extension techniques*.

ISO 4873, *Information processing — ISO 8-bit code for information interchange — Structure and rules for implementation*.

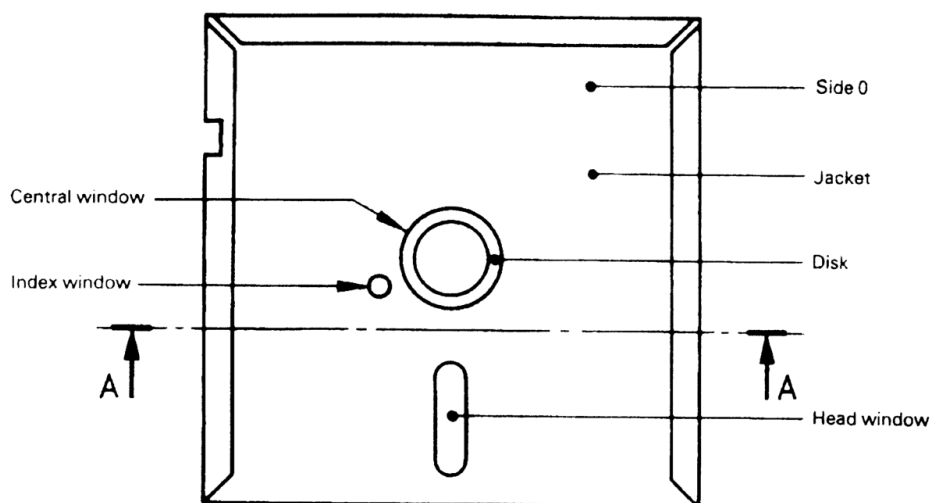

Figure 1 — Flexible disk cartridge

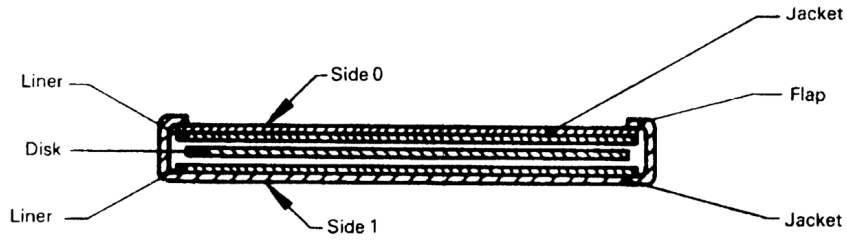

Figure 2 — Section A-A

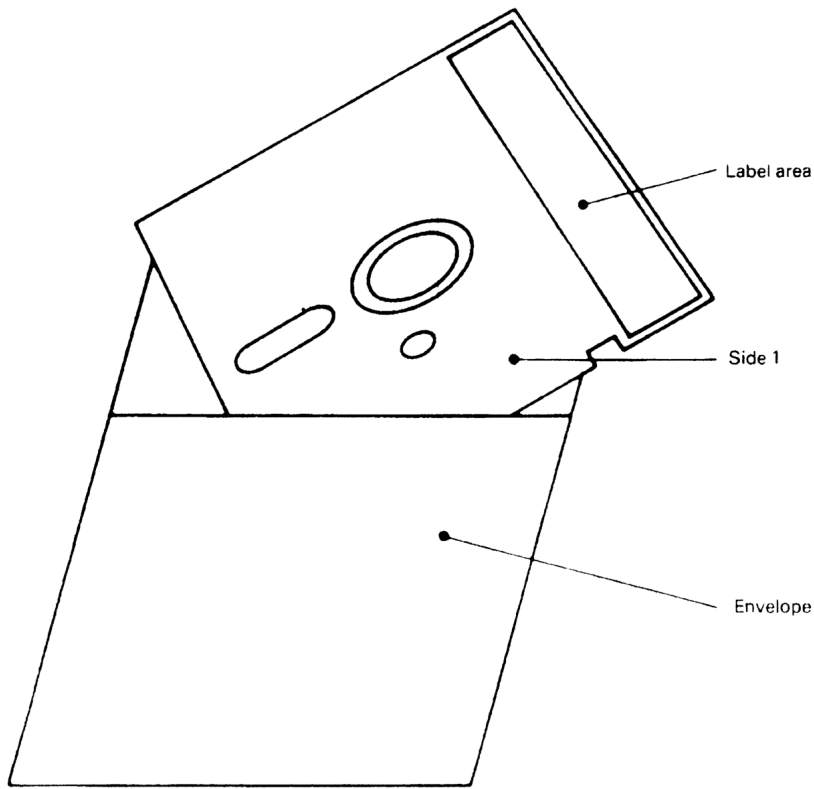

Figure 3 — Protective envelope with cartridge

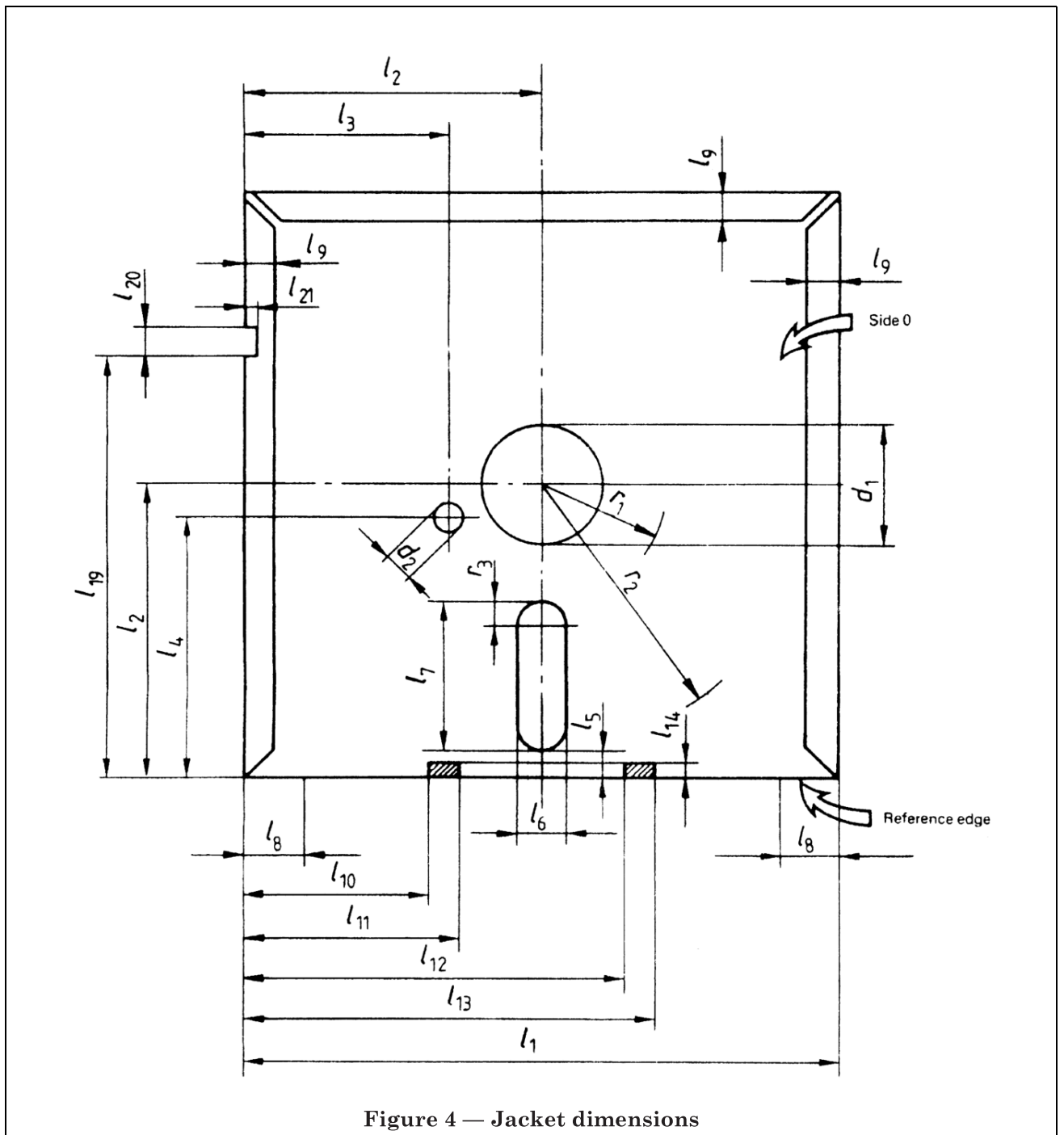

Figure 4 — Jacket dimensions

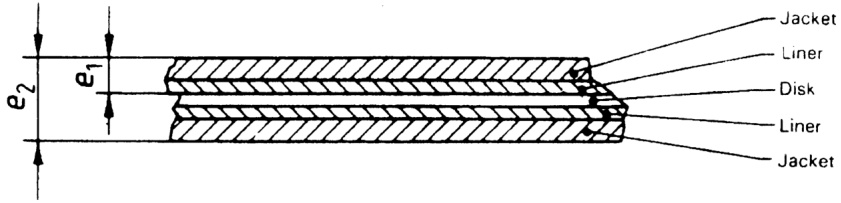

Figure 5 — Cartridge thickness

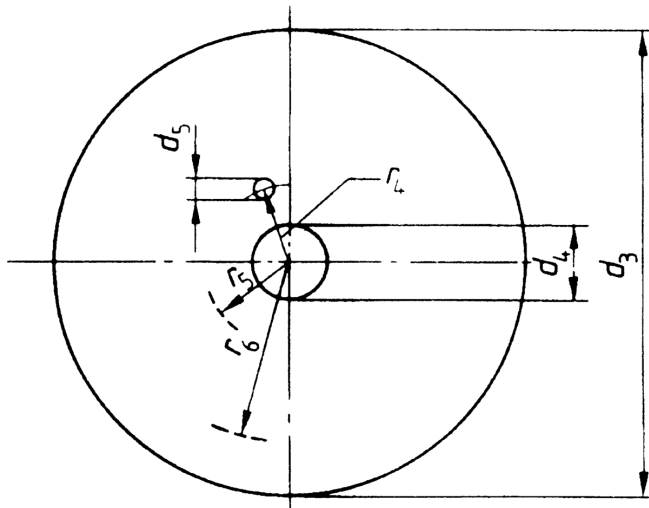

Figure 6 — Disk dimensions

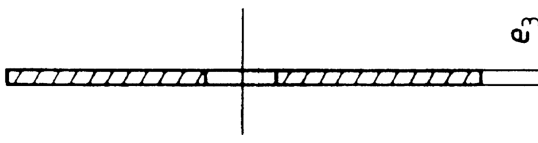
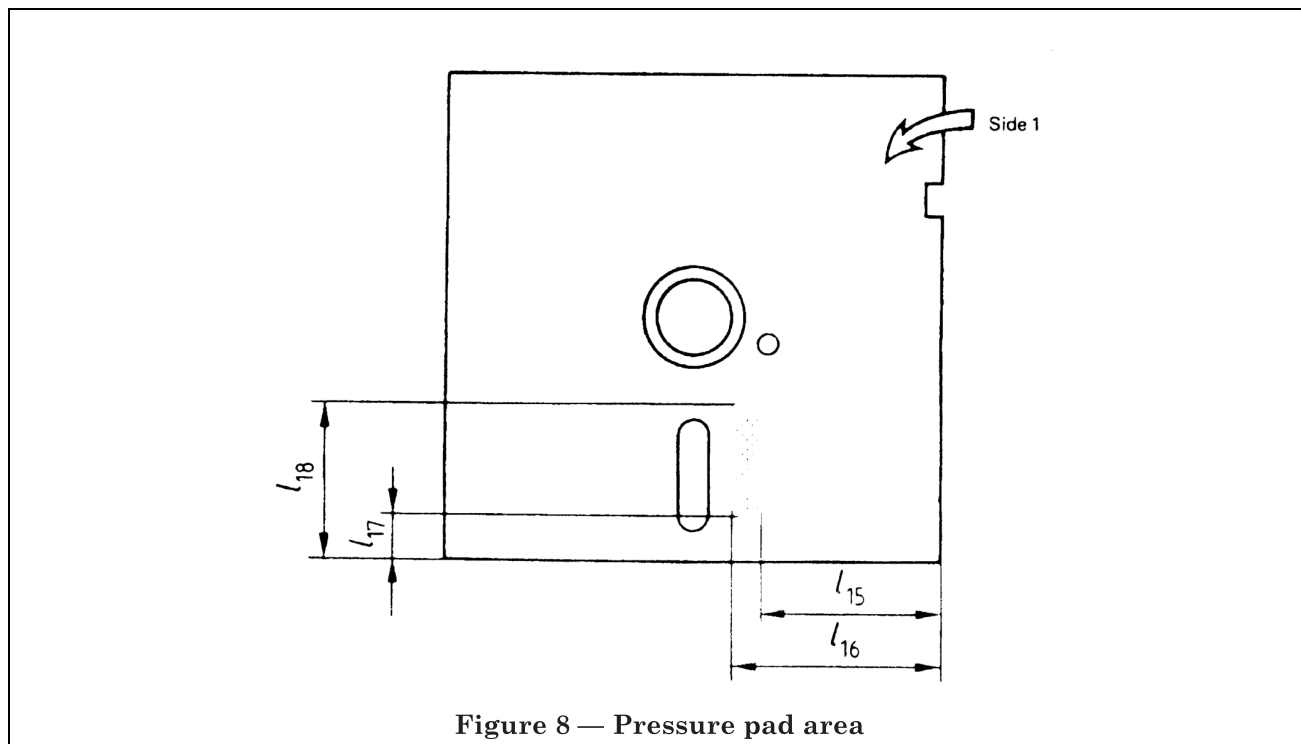

Figure 7 — Disk thickness



Annex A Measurement of the cartridge thickness

(This annex forms part of the standard.)

A.1 Maximum thickness

This value shall be measured for all edges using the gauge of Figure 9. The cartridge shall be capable of entering the gauge for at least 15 mm (0.59 in) when a force of 1 N max. (3.6 ozf max.) is applied on the opposite edge.

A.2 Minimum thickness

This value shall be measured for all edges using the gauge of Figure 10. This gauge has a length of 40 mm (1.57 in). When submitted to a force of 1 N (3.6 ozf) the cartridge shall enter the slot by less than 1 mm (0.039 in).

A.3 Thickness of the flaps (if any)

This thickness shall be measured with the stylus of Figure 11. The cartridge is placed on a horizontal surface with flaps opposite to the bottom surface.

The stylus is put on the flap, its axis being perpendicular to the cartridge edge. The stylus is loaded with a force of 1 N (3.6 ozf). The total thickness is measured with a dial gauge. The stylus is then moved radially to the nearest internal zone of the cartridge and the thickness is measured again. The difference between the two values measured is the contribution of the flap to the total thickness of the cartridge.

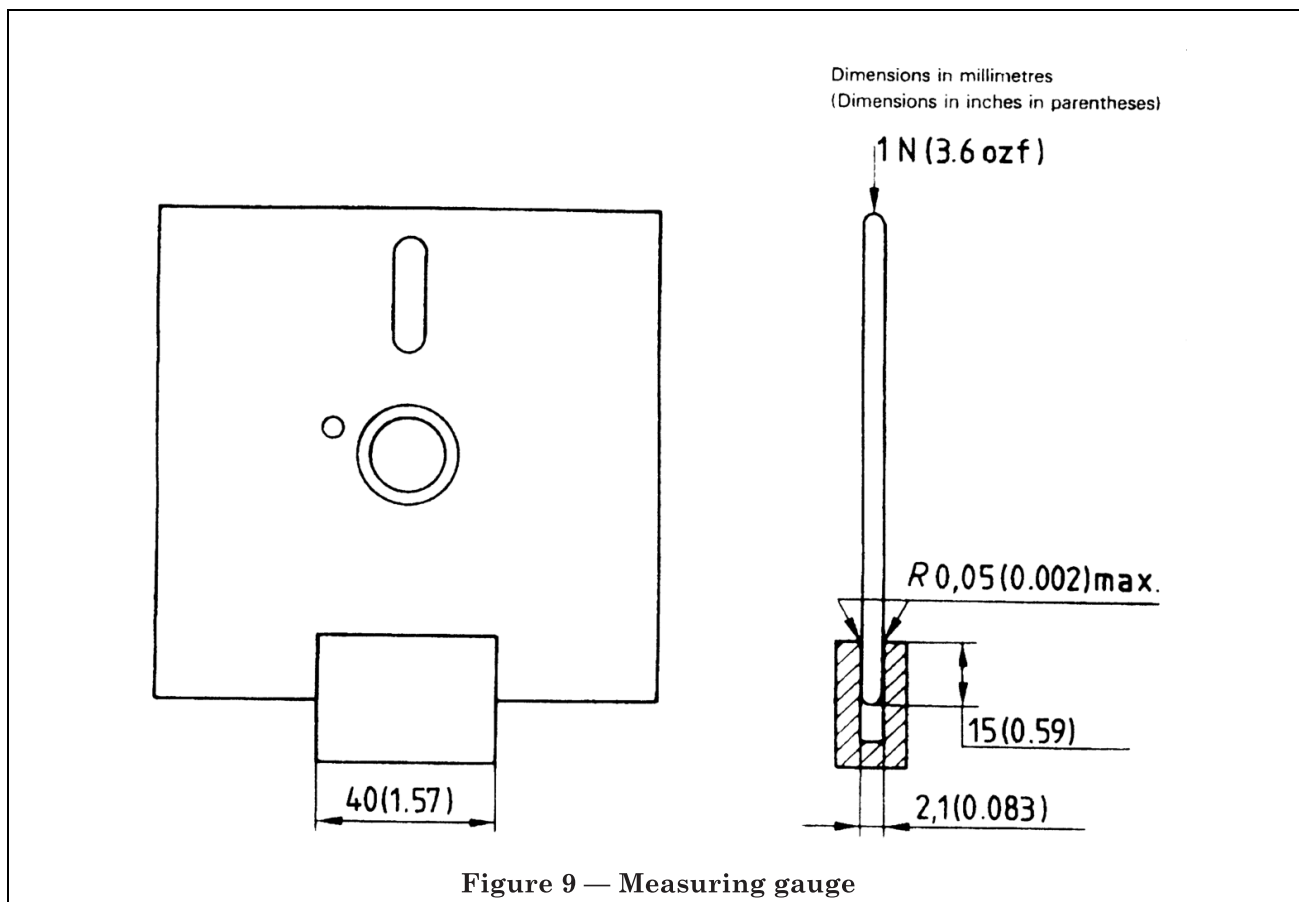

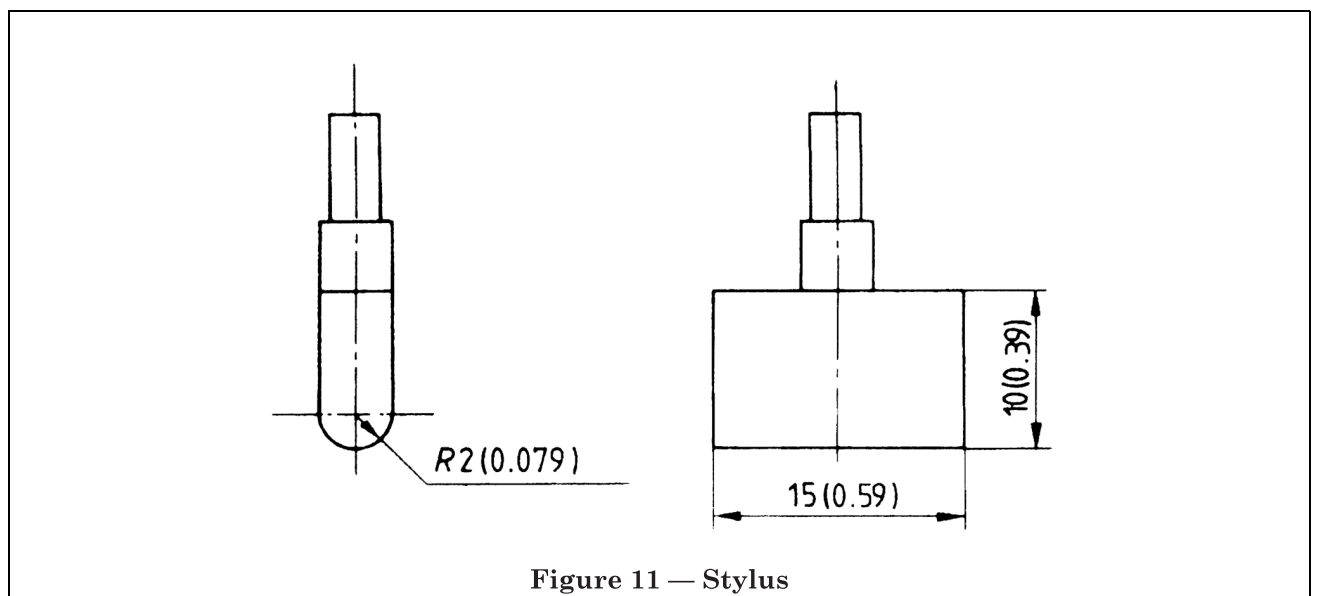
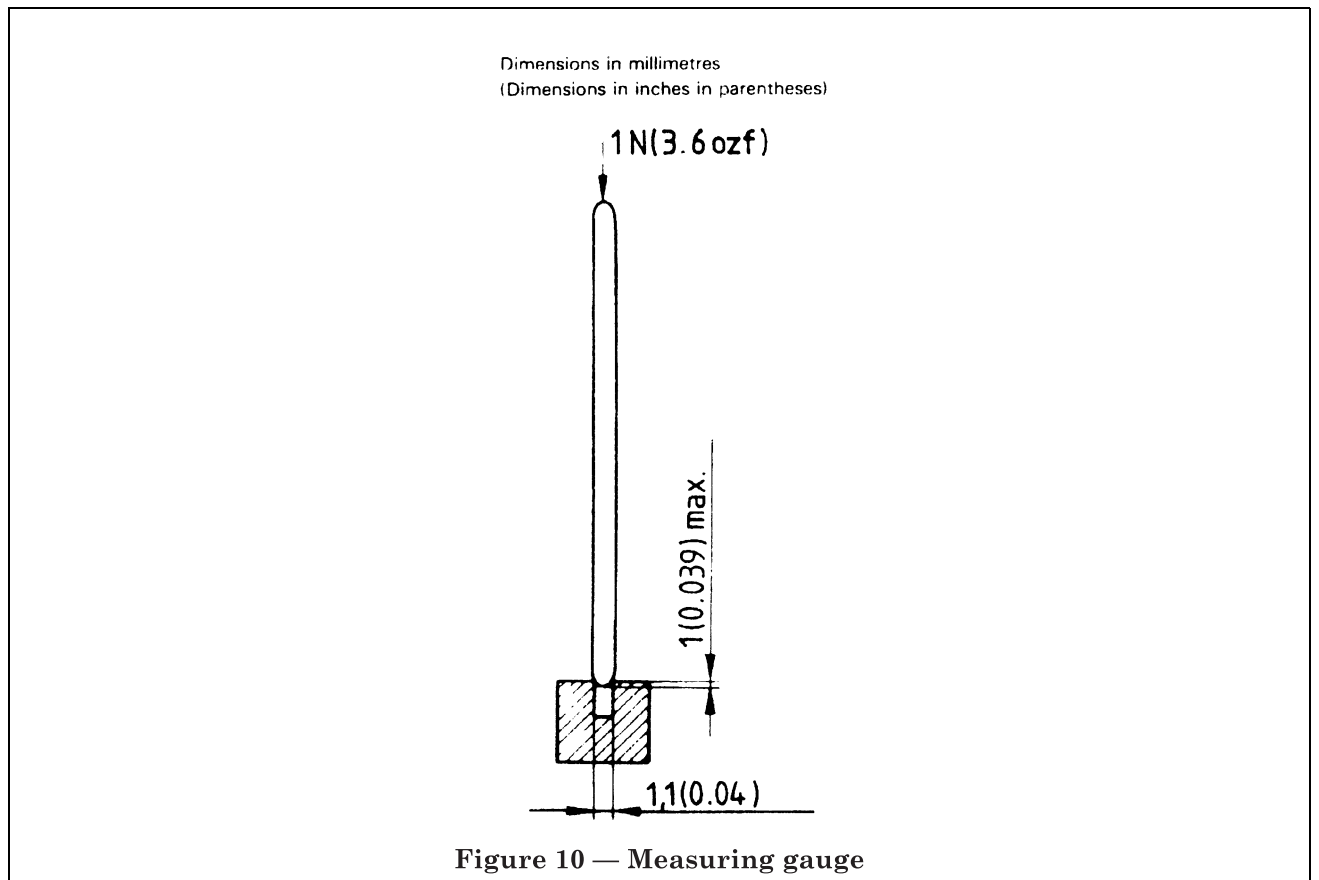

Annex B Measurement of light transmittance

(This annex forms part of the standard.)

B.0 Introduction

The following description outlines the general principle of the measuring equipment and the measuring method to be applied when measuring the radiation (light) transmittance of the jacket and of the magnetic disk.

For the purpose of this International Standard, "light transmittance" is defined by convention as the relationship between the reading obtained from the test device with the sample inserted and the reading obtained when no sample is present. The transmittance value is expressed as the percentage ratio of the two readings.

The essential elements of the measuring equipment are

- the radiation source;
- the photo diode;
- the optical path;
- the measuring circuitry.

B.1 Description of the measuring equipment

B.1.1 Radiation source

An infra red light-emitting diode (LED) with the following parameters shall be used:

Wavelength at peak emission $\lambda_{\text{peak}} = 940 \pm 10$ nm

Half-power band width $b = \pm 25$ nm

NOTE Earlier International Standards for unrecorded flexible disk cartridges required the use of an LED with a nominal wavelength of 900 nm, which is no longer available.

B.1.2 Radiation receiver

A flat silicon photo diode shall be used as the radiation receiver. It shall be operated in the shortcircuit mode. The active area of the diode shall be equal to, or at the most 20 % larger than, the open area of the aperture. This condition guarantees a linear dependency of the short circuit diode current on the light intensity.

B.1.3 Optical path (see Figure 12)

The optical axis of the set up shall be perpendicular to the disk.

The distance from the emitting surface of the LED to the disk shall be

$$L_1 = \frac{d_{\text{max}}}{2 \tan \alpha}$$

where

d_{max} is the maximum diameter of the index window;

α is the angle where the relative intensity of the LED is equal to, or greater than, 95 % of the maximum intensity of the optical axis.

The aperture shall have a thickness of between 1,2 to 1,4 mm (0.047 to 0.055 in) and a diameter given by

$$D = (2 L_2 \tan \alpha) \text{ mm}$$

$$L_2 = (L_1 \pm 1,5) \text{ mm}$$

Its surfaces shall be matt black. The whole device should be enclosed within a light-tight casing.

B.1.4 *Measuring circuitry*

Figure 13 shows the recommended circuitry with the following components:

- E : regulated power supply with variable output voltage
- R : current-limiting resistor
- LED : light-emitting diode
- D_i : Si photo diode
- A : operational amplifier
- R_{f0} , R_{f1} : feedback resistors
- S : gain switch
- V : voltmeter

The forward current of the LED and consequently its radiation power can be varied by means of the power supply E. D_i is working in the short circuit mode. The output voltage of the operational amplifier is given by

$$V_0 = I_k \times R_f$$

and is therefore a linear function of the light intensity. I_k is the short circuit current of D_i

R_{f0} and R_{f1} shall be low-temperature drift resistors with an accuracy of 1 %. The following ratio applies

$$\frac{R_{f0}}{R_{f1}} = \frac{1}{50}$$

B.2 *Measuring method*

B.2.1 *Measurement of the disk*

The measurements shall be taken within an annular band whose boundaries are tangential to the index window.

- S is set to position 0. With the index window in front of the photo diode, the voltmeter is set to full-scale reading (100 % transmittance) by varying the output voltage of E.
- The disk is rotated until the photo diode is covered by the disk. S is set to position 1. Full deflection of the voltmeter now represents 2 % transmittance.

The disk is rotated slowly for one revolution and the readings of the voltmeter are observed.

B.2.2 *Measurement of the jacket*

The same procedure applies to the jacket measurement, except that the jacket without a disk shall be rotated.

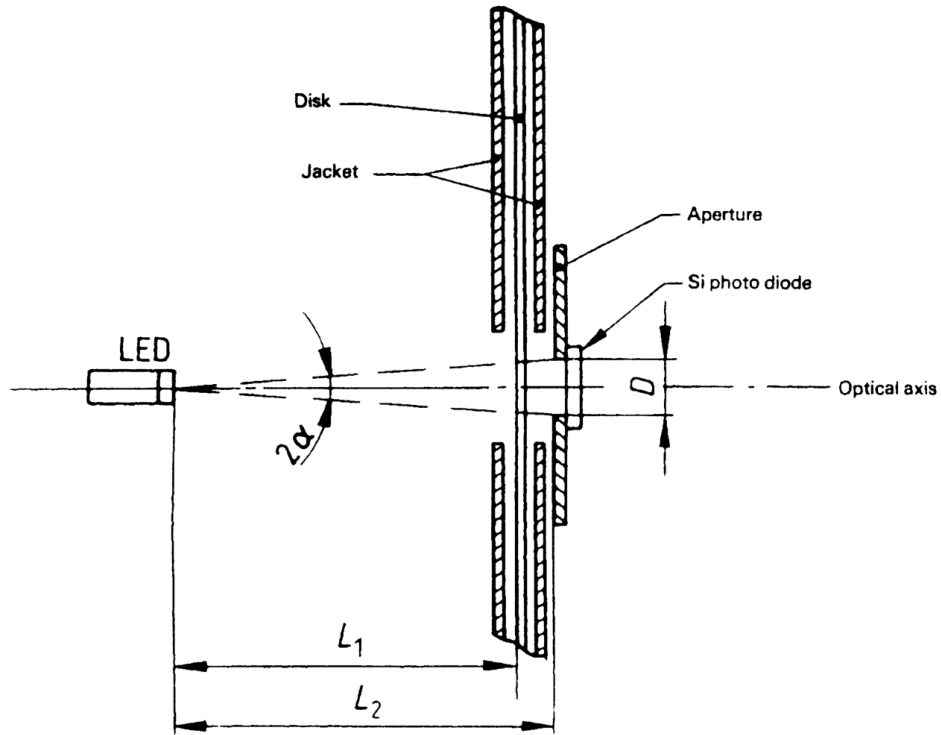

Figure 12 — Measuring device

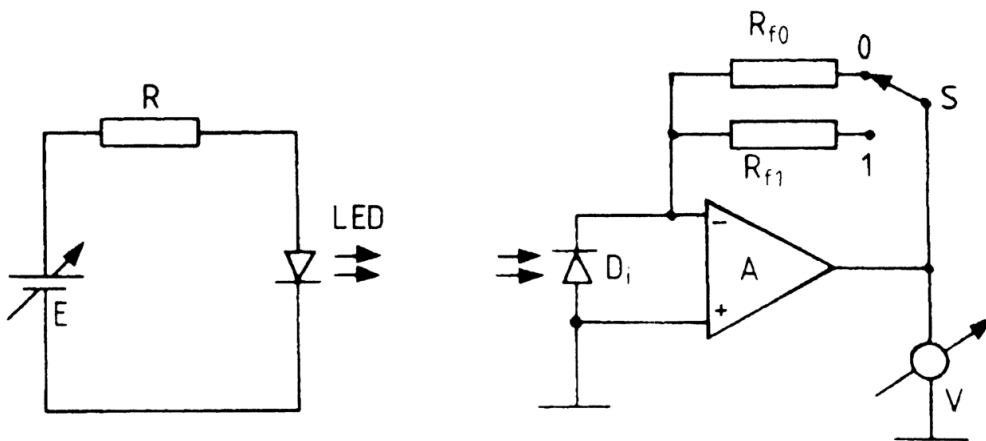

Figure 13 — Electronic circuitry

Publications referred to

See national foreword.

BS 7023-1:
1988
EN 28378-1:
1989
ISO 8378-1:
1986

BSI — British Standards Institution

BSI is the independent national body responsible for preparing British Standards. It presents the UK view on standards in Europe and at the international level. It is incorporated by Royal Charter.

Revisions

British Standards are updated by amendment or revision. Users of British Standards should make sure that they possess the latest amendments or editions.

It is the constant aim of BSI to improve the quality of our products and services. We would be grateful if anyone finding an inaccuracy or ambiguity while using this British Standard would inform the Secretary of the technical committee responsible, the identity of which can be found on the inside front cover.
Tel: 020 8996 9000. Fax: 020 8996 7400.

BSI offers members an individual updating service called PLUS which ensures that subscribers automatically receive the latest editions of standards.

Buying standards

Orders for all BSI, international and foreign standards publications should be addressed to Customer Services. Tel: 020 8996 9001. Fax: 020 8996 7001.

In response to orders for international standards, it is BSI policy to supply the BSI implementation of those that have been published as British Standards, unless otherwise requested.

Information on standards

BSI provides a wide range of information on national, European and international standards through its Library and its Technical Help to Exporters Service. Various BSI electronic information services are also available which give details on all its products and services. Contact the Information Centre.
Tel: 020 8996 7111. Fax: 020 8996 7048.

Subscribing members of BSI are kept up to date with standards developments and receive substantial discounts on the purchase price of standards. For details of these and other benefits contact Membership Administration.
Tel: 020 8996 7002. Fax: 020 8996 7001.

Copyright

Copyright subsists in all BSI publications. BSI also holds the copyright, in the UK, of the publications of the international standardization bodies. Except as permitted under the Copyright, Designs and Patents Act 1988 no extract may be reproduced, stored in a retrieval system or transmitted in any form or by any means – electronic, photocopying, recording or otherwise – without prior written permission from BSI.

This does not preclude the free use, in the course of implementing the standard, of necessary details such as symbols, and size, type or grade designations. If these details are to be used for any other purpose than implementation then the prior written permission of BSI must be obtained.

If permission is granted, the terms may include royalty payments or a licensing agreement. Details and advice can be obtained from the Copyright Manager.
Tel: 020 8996 7070.

BSI
389 Chiswick High Road
London
W4 4AL