

Safety of earth-moving machinery —

Part 1: Specification for hydraulic excavator and backhoe loader boom lowering control device

ICS 53.100

National foreword

This British Standard reproduces verbatim ISO 8643:1997 and implements it as the UK national standard. It supersedes BS 6912-1:1988 which is withdrawn.

The UK participation in its preparation was entrusted by Technical Committee B/513, Construction equipment and plant, and site safety, to Subcommittee B/513/1, Earth-moving machinery (International), which has the responsibility to:

- aid enquirers to understand the text;
- present to the responsible international/European committee any enquiries on the interpretation, or proposals for change, and keep the UK interests informed;
- monitor related international and European developments and promulgate them in the UK.

A list of organizations represented on this subcommittee can be obtained on request to its secretary.

Cross-references

The British Standards which implement international or European publications referred to in this document may be found in the BSI Standards Catalogue under the section entitled “International Standards Correspondence Index”, or by using the “Find” facility of the BSI Standards Electronic Catalogue.

A British Standard does not purport to include all the necessary provisions of a contract. Users of British Standards are responsible for their correct application.

Compliance with a British Standard does not of itself confer immunity from legal obligations.

Summary of pages

This document comprises a front cover, an inside front cover, pages i and ii, the ISO title page, page ii, pages 1 to 4 and a back cover.

This standard has been updated (see copyright date) and may have had amendments incorporated. This will be indicated in the amendment table on the inside front cover.

Amendments issued since publication

Amd. No.	Date	Comments

This British Standard, having been prepared under the direction of the Sector Board for Building and Civil Engineering, was published under the authority of the Standards Board and comes into effect on 15 December 1997

© BSI 04-1999

ISBN 0 580 28838 2

Contents

	Page
National foreword	Inside front cover
Foreword	ii
Introduction	1
1 Scope	1
2 Normative reference	1
3 Definitions	1
4 Requirements for object handling	1
5 Test method	2
Figure 1	2
Figure 2	3
Figure 3	3

INTERNATIONAL
STANDARD

ISO
8643

Second edition
1997-05-15

**Earth-moving machinery — Hydraulic
excavator and backhoe loader
boom-lowering control device —
Requirements and tests**

*Engins de terrassement — Dispositif de contrôle d'abaissement de la
flèche des pelles et chargeuses-pelleteuses hydrauliques — Exigences et
méthodes d'essai*



Reference number
ISO 8643:1997(E)

Foreword

ISO (the International Organization for Standardization) is a worldwide federation of national standards bodies (ISO member bodies). The work of preparing International Standards is normally carried out through ISO technical committees. Each member body interested in a subject for which a technical committee has been established has the right to be represented on that committee. International organizations, governmental and non-governmental, in liaison with ISO, also take part in the work. ISO collaborates closely with the International Electrotechnical Commission (IEC) on all matters of electrotechnical standardization.

Draft International Standards adopted by the technical committees are circulated to the member bodies for voting. Publication as an international Standard requires approval by at least 75 % of the member bodies casting a vote.

International Standard ISO 8643 was prepared by Technical Committee ISO/TC 127, *Earth-moving machinery*, Subcommittee SC 2, *Safety requirements and human factors*.

This second edition cancels and replaces the first edition (ISO 8643:1988), which has been technically revised.

Descriptors: Earth-moving equipment, hydraulic excavators, loaders, hydraulic systems, accident prevention, control devices, specifications, safety requirements, tests.

Introduction

Where excavators or backhoe loaders are used for handling objects, a failure or rupture in the hydraulic boom circuit may endanger persons under raised loads.

This risk can be reduced by applying a control device, which ensures controlled lowering of the boom load in the case of a hydraulic line failure or rupture in the boom circuit.

Test procedures are based on the special design characteristics of the hydraulic systems of hydraulic excavators and the backhoe part of backhoe loaders, and conditions of use.

1 Scope

This International Standard establishes uniform requirements and test procedures for boom-lowering control devices fitted on boom-lift cylinders to control the rate of drop in the case of a hydraulic line failure or rupture.

This International Standard applies to boom-lowering control devices on hydraulic excavators and the backhoe part of backhoe loaders, when used for handling and lifting objects.

2 Normative reference

The following standard contains provisions which, through reference in this text, constitute provisions of this International Standard. At the time of publication, the edition indicated was valid. All standards are subject to revision, and parties to agreements based on this International Standard are encouraged to investigate the possibility of applying the most recent edition of the standard indicated below. Members of IEC and ISO maintain registers of currently valid International Standards. ISO 6165:1997, *Earth-moving machinery — Basic types — Vocabulary*.

3 Definitions

For the purposes of this International Standard, the definitions given in ISO 6165 and the following definitions apply.

3.1

boom control system

hydraulic control valve(s) (including pilot and slave valves) used for raising and lowering the boom

3.2

boom-lowering control device

hydraulic control valve(s) used for controlled boom lowering

3.3

failure-simulating device

hydraulic valve(s) used for simulating a hydraulic line rupture in the boom circuit

3.4

rated lift capacity

the smaller of either the rated tipping capacity or the rated hydraulic lift capacity¹⁾

3.5

lift point

one point as defined by the manufacturer for the purpose of lifting. It is defined by the lift point height and the lift point radius

3.6

lift point height

vertical distance from the lift point to the ground reference plane (GRP)

3.7

lift point radius

horizontal distance from the lift point to the axis of rotation

4 Requirements for object handling

4.1 For hydraulic excavators and the backhoe part of backhoe loaders used in object handling, a lowering control device shall be provided which prevents uncontrolled lowering of the boom in the case of a hydraulic line failure or rupture.

4.2 The devices shall operate automatically while the boom-lift cylinders are pressurized. These devices are considered satisfactory when performance meets the requirements defined in clause 5.

For testing the device, the drop rate of the load due to internal leakage in the system shall not exceed 10 mm/s when the control is in the neutral position.

The operation of the device shall not detract from the normal response of the machine and shall not, at any time, endanger the stability of the machine.

4.3 A relief valve to protect the cylinder may be fitted between the cylinder and the control device.

4.4 In the case of a failure of the boom control system, or after a boom line rupture, lowering of the load shall be possible without endangering person(s) or the stability of the machine.

¹⁾ From: ISO 10567:1992, *Earth-moving machinery — Hydraulic excavators — Lift capacity*.

4.5 The boom-lift cylinder shall have the following firmly attached to it:

- a) the control device as well as related tubes and fittings between the control device and the cylinder; and
- b) when provided, a separate relief valve as well as related tubes and fittings to connect it in parallel with the control device.

Tubes and fittings related to connecting the control valve, and the relief valve when provided in parallel to the cylinder, shall have a minimum burst pressure of four times the working circuit pressure for that part of the system.

4.6 Signal lines for testing device(s) and equalizing lines between lift cylinders are permissible, if rupture of one of these lines results in an oil leakage of not more than 10 l/min for each cylinder at an oil temperature of approximately 40 °C to 50 °C at the specified working circuit pressure.

5 Test method

5.1 Apparatus

5.1.1 Stopwatch

5.1.2 Measuring tape or scale

5.1.3 Thermometer, measuring from 0 °C to 100 °C.

5.1.4 *Measuring container*, of 2 litre capacity, or a *flowmeter*.

5.1.5 *Collecting container*, for hydraulic oil or, alternatively, an *oil return line* to the tank.

5.1.6 *Test load*, of mass (50 ± 10) % of the rated lift capacity at a specific lift point radius.

5.2 Preparation for test

5.2.1 Test methods ensuring equal results should be used, for example a level site near a vertical wall to which a paper is pinned to record the load displacement in the tube or hose-rupture simulation test, when the load is fitted with a stylus.

5.2.2 A failure-simulating device shall be installed in any connecting line whose failure could cause the boom to lower. The tube for testing shall not increase the resistance of the connecting line.

Examples of such installations are as follows:

- a) in the line between the boom-lift cylinder and control valve, as shown in Figure 1;
- b) in the signal line between the boom-lift cylinder and testing device (pressure gauge), as shown in Figure 2;
- c) in the equalizing line between the boom-lift cylinders, as shown in Figure 3.

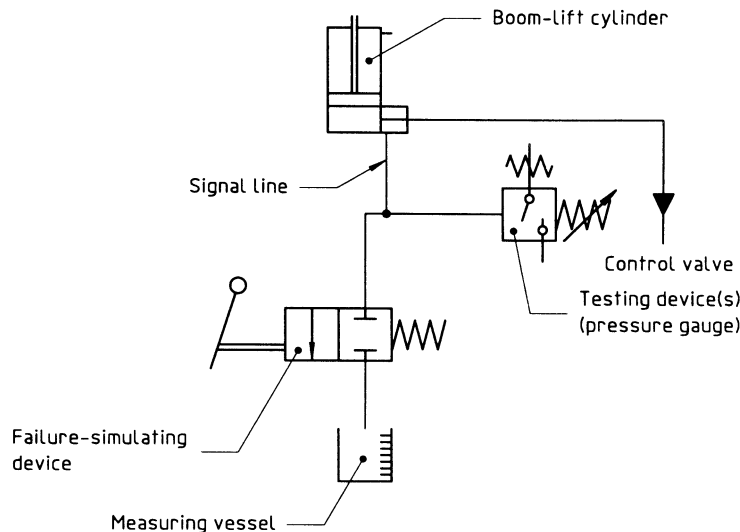

Figure 1

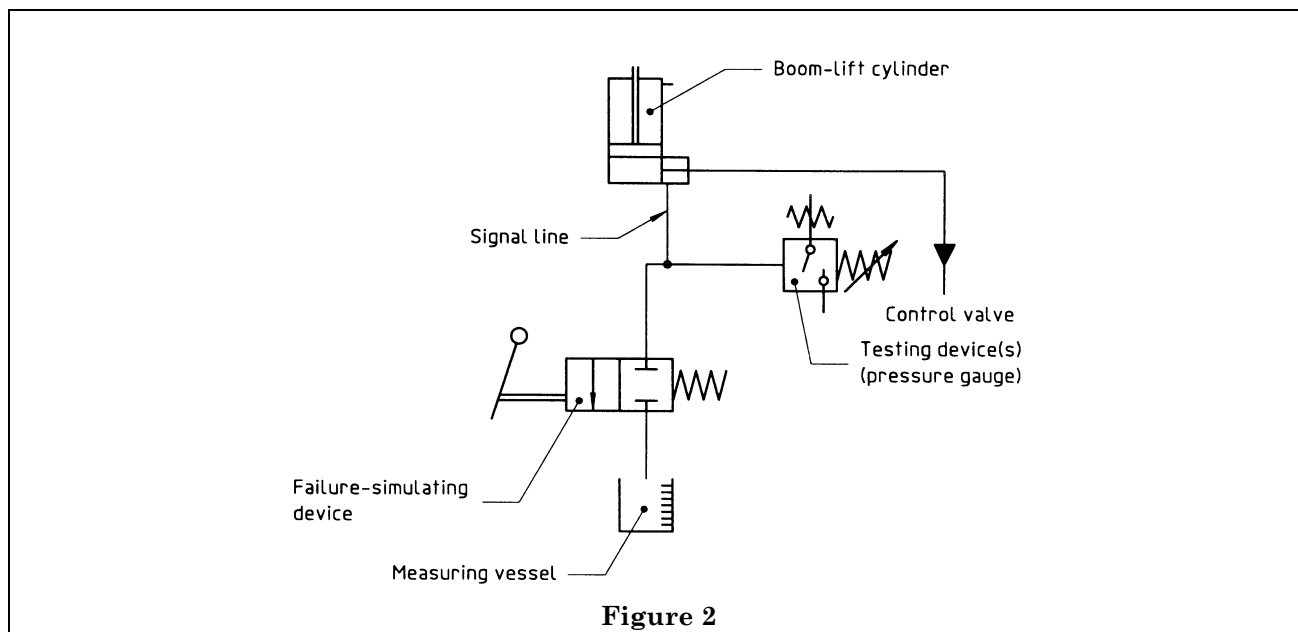

Figure 2

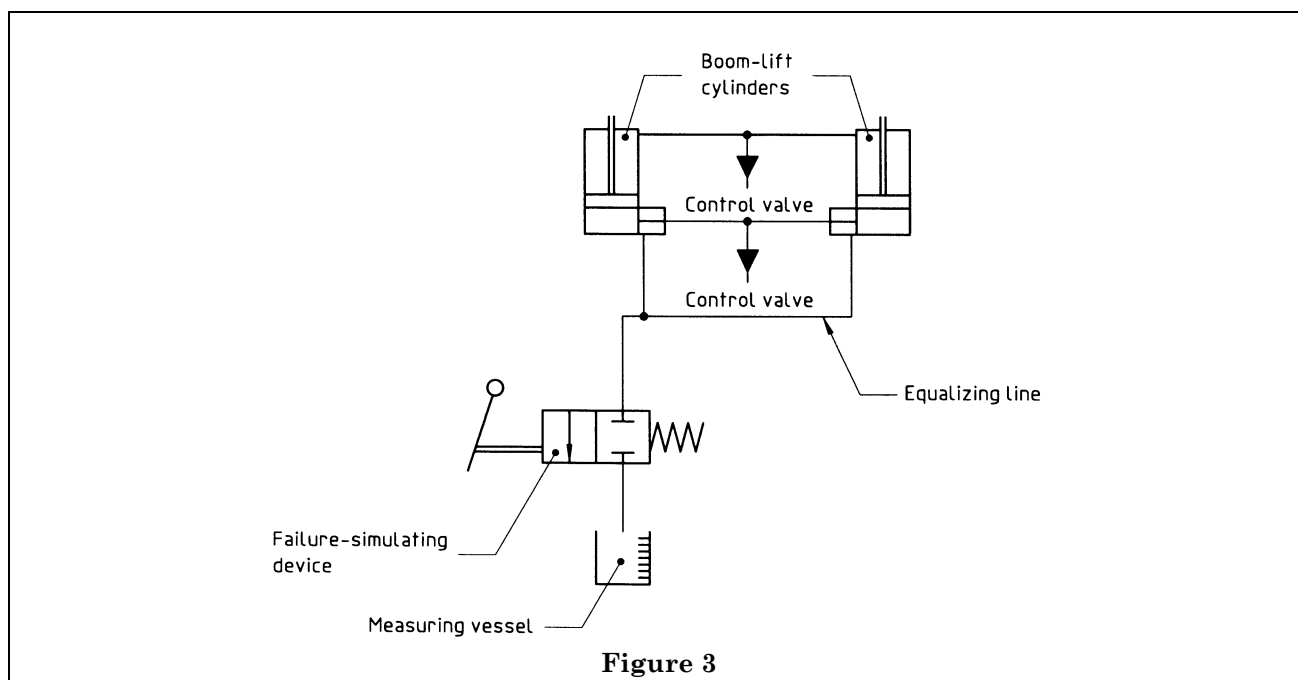

Figure 3

5.2.3 The complete hydraulic system shall be operated until the temperature of the hydraulic oil in the oil reservoir is approximately 40 °C to 50 °C. The hydraulic fluid shall be of the type and grade specified by the manufacturer.

5.3 Testing of control device

5.3.1 The test load shall be at the lift point radius which results in a moment equal to (50 ± 10) % of the moment developed by the rated lift capacity at a specific lift point radius.

5.3.2 The functions of raising and lowering the boom shall be smooth and at a reduced speed of 200 mm/s max., measured at the test load.

5.3.3 The load shall be lowered and set down after each test in accordance with 4.5.

5.4 Testing of holding position

5.4.1 The test load shall be raised approximately 1 m above ground level, with the boom control valve(s) in the neutral position.

5.4.2 The failure-simulating device between the lift cylinders and the boom control valve shall be opened.

5.4.3 The total drop of the load during the initial 10 s shall be measured; it shall not exceed 100 mm.

5.5 Testing during raising

5.5.1 The test load shall be lifted smoothly and continuously without shock (see **5.3.2**).

5.5.2 The failure-simulating device between the lift cylinder(s) and the boom control valve shall be opened.

5.5.3 The total drop of the load during the initial 10 s shall be measured; it shall not exceed 100 mm.

5.6 Testing during lowering

5.6.1 The test load shall be lowered smoothly and continuously without shock (see **5.3.2**).

5.6.2 The failure-simulating device between the lift cylinder(s) and the boom control valve shall be opened.

5.6.3 The increase in the lowering speed of the test load shall be less than 100 % increase of the initial speed. After the control is moved to the neutral position, the boom-lowering control device shall be able to limit boom movement so that the total drop of the load during the initial 10 s of the test does not exceed 100 mm.

5.7 Testing of equalizing lines or signal lines

5.7.1 Testing shall be performed without load.

5.7.2 The boom shall be raised to its maximum lift height, and the boom control valve kept in the "lift" position.

5.7.3 The failure-simulating device shall be opened.

5.7.4 The oil leakage per cylinder shall not exceed 10 l/min.

BSI — British Standards Institution

BSI is the independent national body responsible for preparing British Standards. It presents the UK view on standards in Europe and at the international level. It is incorporated by Royal Charter.

Revisions

British Standards are updated by amendment or revision. Users of British Standards should make sure that they possess the latest amendments or editions.

It is the constant aim of BSI to improve the quality of our products and services. We would be grateful if anyone finding an inaccuracy or ambiguity while using this British Standard would inform the Secretary of the technical committee responsible, the identity of which can be found on the inside front cover. Tel: 020 8996 9000. Fax: 020 8996 7400.

BSI offers members an individual updating service called PLUS which ensures that subscribers automatically receive the latest editions of standards.

Buying standards

Orders for all BSI, international and foreign standards publications should be addressed to Customer Services. Tel: 020 8996 9001. Fax: 020 8996 7001.

In response to orders for international standards, it is BSI policy to supply the BSI implementation of those that have been published as British Standards, unless otherwise requested.

Information on standards

BSI provides a wide range of information on national, European and international standards through its Library and its Technical Help to Exporters Service. Various BSI electronic information services are also available which give details on all its products and services. Contact the Information Centre. Tel: 020 8996 7111. Fax: 020 8996 7048.

Subscribing members of BSI are kept up to date with standards developments and receive substantial discounts on the purchase price of standards. For details of these and other benefits contact Membership Administration. Tel: 020 8996 7002. Fax: 020 8996 7001.

Copyright

Copyright subsists in all BSI publications. BSI also holds the copyright, in the UK, of the publications of the international standardization bodies. Except as permitted under the Copyright, Designs and Patents Act 1988 no extract may be reproduced, stored in a retrieval system or transmitted in any form or by any means – electronic, photocopying, recording or otherwise – without prior written permission from BSI.

This does not preclude the free use, in the course of implementing the standard, of necessary details such as symbols, and size, type or grade designations. If these details are to be used for any other purpose than implementation then the prior written permission of BSI must be obtained.

If permission is granted, the terms may include royalty payments or a licensing agreement. Details and advice can be obtained from the Copyright Manager. Tel: 020 8996 7070.