

Testing earth-moving machinery —

Part 3: Measurement of tool forces of hydraulic excavators

Committees responsible for this British Standard

The preparation of this British Standard was entrusted by the Road Engineering Standards Policy Committee (RDB/-) to Technical Committee RDB/21, upon which the following bodies were represented:

AFRC Institute of Engineering Research
 Associated Offices Technical Committee
 British Coal Corporation
 Construction Industry Training Board
 Construction Plant-Hire Association
 Federation of Civil Engineering Contractors
 Federation of Manufacturers of Construction Equipment and Cranes
 Health and Safety Executive
 Institution of Civil Engineers
 Institution of Highways and Transportation
 Ministry of Defence

This British Standard, having been prepared under the direction of the Road Engineering Standards Policy Committee, was published under the authority of the Board of BSI and comes into effect on
 31 August 1990

© BSI 10-1999

The following BSI references relate to the work on this standard:
 Committee reference RDB/21
 Draft announced in *BSI News* April 1990

ISBN 0 580 18624 5

Amendments issued since publication

Amd. No.	Date	Comments

Contents

	Page
Committees responsible	Inside front cover
National foreword	ii
<hr/>	
1 Scope	1
2 Normative references	1
3 Definitions	1
4 Apparatus	1
5 Test site	2
6 Preparation for test	2
7 Methods of measuring tool forces	2
8 Test report	3
<hr/>	
Figure 1 — Hydraulic excavator fitted with hoe — Typical arrangement for measuring maximum hoe tool force using bucket cylinder	4
Figure 2 — Hydraulic excavator fitted with hoe — Typical arrangement for measuring maximum hoe tool force using arm cylinder	5
Figure 3 — Hydraulic excavator fitted with shovel — Typical arrangement for measuring maximum shovel tool force using bucket cylinder	5
Figure 4 — Hydraulic excavator fitted with shovel — Typical arrangement for measuring maximum shovel tool force using arm cylinder	6
Figure 5 — Grab or clamshell — Typical test arrangement for determination of maximum closing force	6
Table 1 — Test results	4
<hr/>	
Publications referred to	Inside back cover
<hr/>	

National foreword

This Part of BS 6911 is a minor revision of BS 6825-1:1987 incorporating changes in the definitions for hydraulic pressure terms. It has been prepared under the direction of the Road Engineering Standards Policy Committee. BS 6911-3 is identical with ISO 6015:1989 “*Earth-moving machinery — Hydraulic excavators — Methods of measuring tool forces*” published by the International Organization for Standardization (ISO). This Part of BS 6911 supersedes BS 6825-1 which is withdrawn.

ISO 6015 was produced as a result of international discussion in which the UK took an active part.

Cross-references

International Standard	Corresponding British Standard
ISO 5998:1986	BS 6912 <i>Safety of earth-moving machinery</i> Part 2:1989 <i>Specification for rated operating load for crawler and wheel loaders</i> (Identical)
ISO 6016:1982	BS 6300:1982 <i>Methods of measuring the masses of whole machines, their equipment and components of earth-moving machinery</i> (Identical)
ISO 6165:1987	BS 6914 <i>Terminology (including definitions of dimensions and symbols) for earth-moving machinery</i> Part 1:1988 <i>Glossary of terms for basic types of earth-moving machinery</i> (Identical)
ISO 6746-1:1987	Part 2:1988 <i>Glossary of terms for base machine</i> (Identical)
ISO 7451:1983	BS 6421:1983 <i>Method for volumetric rating of hoe type buckets of hydraulic excavators used for earth-moving</i> (Identical)
ISO 7546:1983	BS 6422:1983 <i>Method for volumetric rating of loader and front loading excavator buckets used for earth-moving</i> (Identical)

A British Standard does not purport to include all the necessary provisions of a contract. Users of British Standards are responsible for their correct application.

Compliance with a British Standard does not of itself confer immunity from legal obligations.

Summary of pages

This document comprises a front cover, an inside front cover, pages i and ii, pages 1 to 6, an inside back cover and a back cover.

This standard has been updated (see copyright date) and may have had amendments incorporated. This will be indicated in the amendment table on the inside front cover.

1 Scope

This International Standard specifies methods for determining the tool forces of hydraulic excavators, together with their limiting conditions. It applies to all types of hydraulic excavators, crawler or wheeled machines, and with or without outriggers, as defined in ISO 6165.

2 Normative references

The following standards contain provisions which, through reference in this text, constitute provisions of this International Standard. At the time of publication, the editions indicated were valid. All standards are subject to revision, and parties to agreements based on this International Standard are encouraged to investigate the possibility of applying the most recent editions of the standards listed below. Members of IEC and ISO maintain registers of currently valid International Standards.

ISO 6016:1982, *Earth-moving machinery — Methods of measuring the masses of whole machines, their equipment and components.*

ISO 6165:1987, *Earth-moving machinery — Basic types — Vocabulary.*

ISO 6746-1:1987, *Earth-moving machinery — Definitions of dimensions and symbols — Part 1: Base machine.*

ISO 7451:1983, *Earth-moving machinery — Hydraulic excavators — Hoe type buckets — Volumetric ratings.*

ISO 7546:1983, *Earth-moving machinery — Loader and front loading excavator buckets — Volumetric ratings.*

3 Definitions

For the purposes of this International Standard, the following definitions apply.

3.1

tool forces

on an excavator fitted with a hoe or shovel, tool forces are the actual forces generated at the bucket lip when operating the bucket or arm cylinder independently

for buckets with a curved or pointed cutting edge the forces shall be measured at the centre of the bucket width

the direction of the tool forces to be measured shall be tangential to the arc described by the bucket lip

3.2

grab and clamshell closing force

maximum force available between the clamshells at the cutting edge or the tips of the teeth when closing

3.3

mass

operating mass of the machine, as defined in ISO 6016

3.4 Hydraulic pressure

3.4.1

working circuit pressure

nominal pressure applied to the specific circuit by the pump(s)

3.4.2

holding circuit pressure

maximum static pressure in a specific circuit limited by a relief valve at a flow no greater than 10 % of the rated circuit flow

3.5 Limiting conditions (see also 7.1)

3.5.1

hydraulic limiting condition

moment when the tool forces or lift capacity are limited by the working or holding circuit pressure

3.5.2

engine stall limiting condition

moment when the tool forces are limited by the engine stalling

3.5.3

tipping limiting condition

moment when the tool forces are limited by the onset of tipping of the machine

3.5.4

slipping limiting condition

moment when the tool forces are limited by the machine slipping on the test surface

4 Apparatus

The apparatus shall comprise the items in 4.1 to 4.4.

4.1 *Load cell or force transducer* appropriate to the magnitude of the tool force to be measured and with an accuracy of $\pm 2\%$ inclusive of the readout device.

4.2 *Hydraulic oil pressure gauge*, with an accuracy of $\pm 2\%$.

4.3 *Wire ropes and shackles, pulley, safety chains and adjustable supporting frames*

4.4 *Apparatus for measuring linear dimensions* to an accuracy of $\pm 2\%$.

5 Test site

The test site shall consist of a substantially level, hard surface, preferably concrete, with anchor points and sufficient space to use load cells (4.1). Where measurements are to be made below the normal ground level, a pit shall be provided of sufficient depth to accept the tool and with enough room to accommodate the load cell, its anchorage and any auxiliary equipment.

NOTE In the preferred method, the force to be measured is applied direct to the load cell (4.1). If the force is applied via a pulley, its friction should be taken into account in order to maintain the overall accuracy of $\pm 2\%$. As the mass of the rope itself may affect the accuracy, it is recommended that the rope should be as short as possible.

6 Preparation for test

The excavator shall be clean, and generally equipped as indicated in ISO 6016.

The machine shall be fitted with the bucket or other attachment and appropriate counterweights, and shall have the tyre pressure, and tyre ballast or track tension as specified by the manufacturer.

The working equipment for each test, using the various bucket pin, bucket link pin or arm pin positions, shall be as specified by the manufacturer (see Figure 1).

Prior to testing, the engine and hydraulic system shall attain the normal working temperature, and the working and holding circuits pressures shall then be checked for compliance with the manufacturer's recommendations.

The machine shall be positioned on the test site (clause 5) and the appropriate bucket or attachment shall be suitably connected to a load cell (4.1) as illustrated in Figure 1 to Figure 5, the linkage position being dependent on which tool force is to be determined.

7 Methods of measuring tool forces

7.1 General

The test shall be conducted with the machine running in accordance with the manufacturer's operating instructions and observing all safety rules.

Safety chains (4.3) shall be fitted to prevent the machine from actually overturning in any test where the tipping limiting condition may occur.

With the engine running at the manufacturer's maximum recommended speed, the required cylinder(s) shall be operated independently and the force at the bucket lip or attachment recorded.

A series of preliminary trials shall be conducted with the equipment boom arm and bucket at different angles in relation to each other (i.e. by varying the cylinder stroke) to obtain the optimum position to give the maximum force.

The limiting conditions, as defined in 3.5, shall be noted for each test (see 8.2).

In the case of the hydraulic limiting condition, the report should note the system or circuit in which the holding pressure was exceeded. If the tipping limiting condition is reached, the tool force shall be measured after the onset of tipping.

Safety chains shall be loose so that the machine can attain the tipping condition and yet be prevented from overturning.

If the slipping limiting condition is reached, the machine shall be anchored and the reported results should indicate that the maximum force was obtained by anchoring the machine.

When alternative pivot positions for the boom, dipper arm, attachment and cylinders and/or a telescopically adjustable boom are available, the relative pin positions of boom, dipper arm and bucket fixing and telescopic boom position as tested shall be recorded.

For excavators fitted with outriggers, the tests shall be conducted with the outriggers raised or lowered as specified by the manufacturer.

Each test shall be conducted three times, and the maximum tool force for each test shall be noted; the arithmetic mean of these three values shall be recorded in the test results.

The tool forces shall be measured in accordance with the above general requirements and the specific requirements given in 7.2, 7.3 and 7.4 and as illustrated in the appropriate figures.

7.2 Excavator fitted as hoe (see Figure 1 and Figure 2)

7.2.1 Maximum hoe tool force using bucket cylinder(s)

This is the maximum force at the bucket lip with the bucket cylinder(s) positioned to provide the maximum curling moment to the bucket around the bucket pivot. The bucket lip shall be moved towards the base machine. The force shall be measured tangential to the arc described by the bucket lip about the bucket pivot (see Figure 1).

7.2.2 *Maximum hoe tool force using arm cylinder(s)*

This is the maximum force at the bucket lip with the arm cylinder positioned to provide the maximum moment to the arm around the arm pivot. The bucket lip shall be moved towards the base machine. The bucket shall be positioned as defined in 7.2.1, except that no part of the bucket shall be outside the arc described by the bucket lip about the arm pivot. The force shall be measured tangential to this arc (see Figure 2).

7.3 *Excavator fitted as shovel* (see Figure 3 and Figure 4)

7.3.1 *Maximum shovel tool force using bucket cylinder(s)*

This is the maximum force at the bucket lip with the bucket cylinder positioned to provide the maximum curling moment to the bucket around the bucket pivot. The bucket lip shall be moved away from the base machine. The force shall be measured tangential to the arc described by the bucket lip about the bucket pivot (see Figure 3).

7.3.2 *Maximum shovel tool force using arm cylinder(s)*

This is the maximum force at the bucket lip with the arm cylinder positioned to provide the maximum moment to the arm around the arm pivot. The bucket lip shall be moved away from the base machine. The bucket is to be positioned as defined in 7.3.1 except that no part of the bucket shall be outside the arc described by the bucket lip about the arm pivot. The force shall be measured tangential to this arc (see Figure 4).

7.4 *Excavator fitted with grab or clamshell attachment*

7.4.1 *Maximum grab or clamshell closing force*

A load sensor is placed between the cutting edges of the clamshell, which is in the position of maximum closing force, applied by the hydraulic closing cylinders or other means. The distance between the cutting edges shall be recorded (see Figure 5).

8 Test report

8.1 General information on machine

The information specified in 8.1.1 to 8.1.3 shall be reported.

8.1.1 *Machine*

- a) type;
- b) model;
- c) manufacturer;
- d) mass of machine as tested (in accordance with ISO 6016), in kilograms;
- e) working or holding circuit pressure setting(s), in kilopascals.

8.1.2 *Type of undercarriage* (i.e. crawler or wheeled machine, in accordance with ISO 6746-1)

a) **Crawler machine:**

- 1) type of track shoe,
- 2) maximum width (over tracks), $W1$, in metres,
- 3) track gauge, $W2$, in metres,
- 4) track shoe width, $W4$, in metres,
- 5) crawler base (distance between vertical centrelines of front and rear idlers or sprockets), $L2$, in metres;

b) **Wheeled machine:**

- 1) track, $W3$, in metres (specifying front and rear if different),
- 2) wheel-base, $L3$, in metres,
- 3) tyre size(s),
- 4) tyre pressure, in kilopascals,
- 5) ballast (if specified), in kilograms.

8.1.3 *Working equipment fitted*

- a) boom length (at available pin or telescoped positions), in metres;
- b) arm length (at available pin or telescoped positions), in metres;
- c) bucket type, rated volume (in accordance with ISO 7451 or ISO 7546) and mass, in kilograms;
- d) attachments (specify) and mass, in kilograms;
- e) counterweights, in kilograms;
- f) outriggers: width between pad centres, outriggers extended, $W6$, in metres.

8.2 Reporting results

The tool forces shall be recorded in accordance with Table 1.

Table 1 — Test results

Equipment fitted	Pin positions and arm length	Force N	Limiting conditions
Maximum hoe tool force using: — bucket cylinder — arm cylinder			
Maximum shovel tool force using: — bucket cylinder — arm cylinder			
Grab or clamshell: closing force	Distance between teeth/cutting edges		

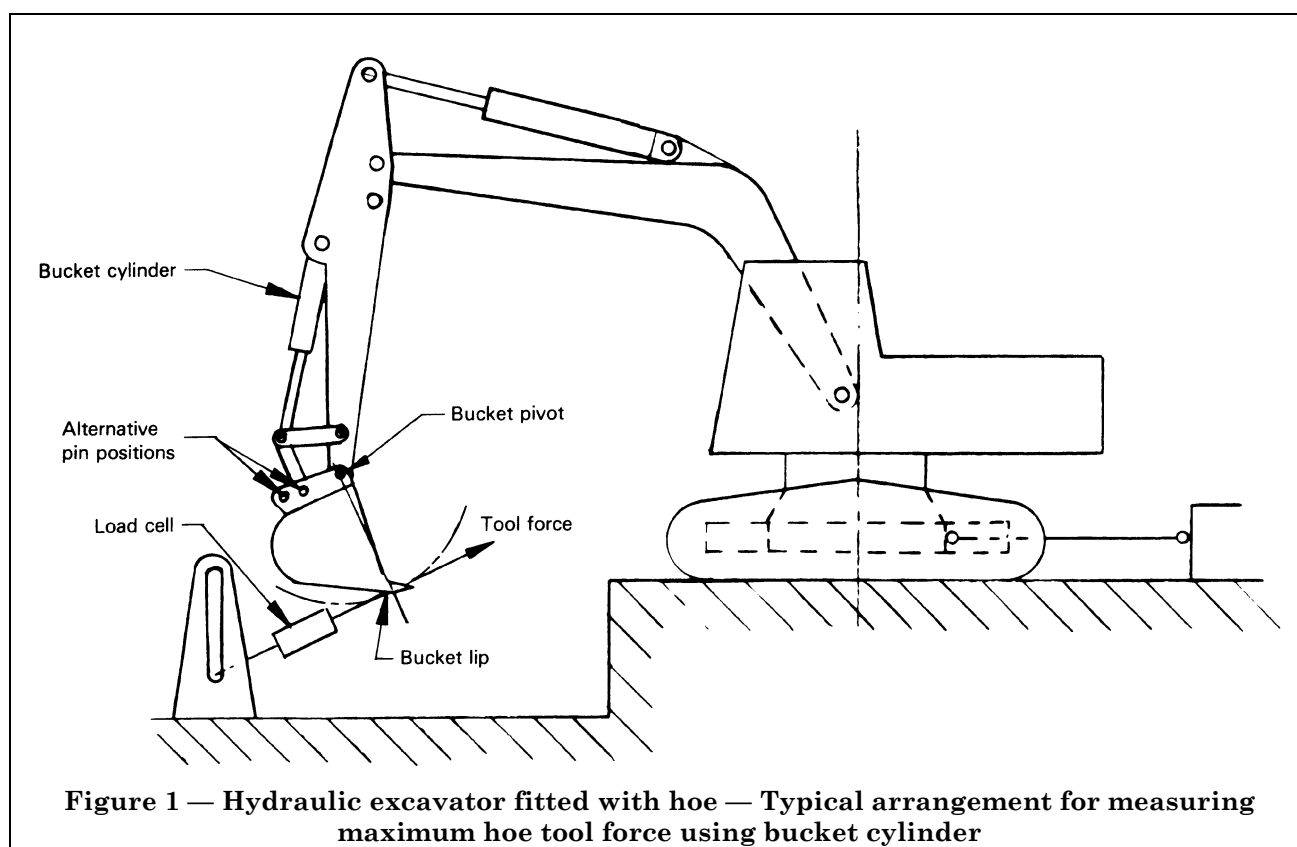

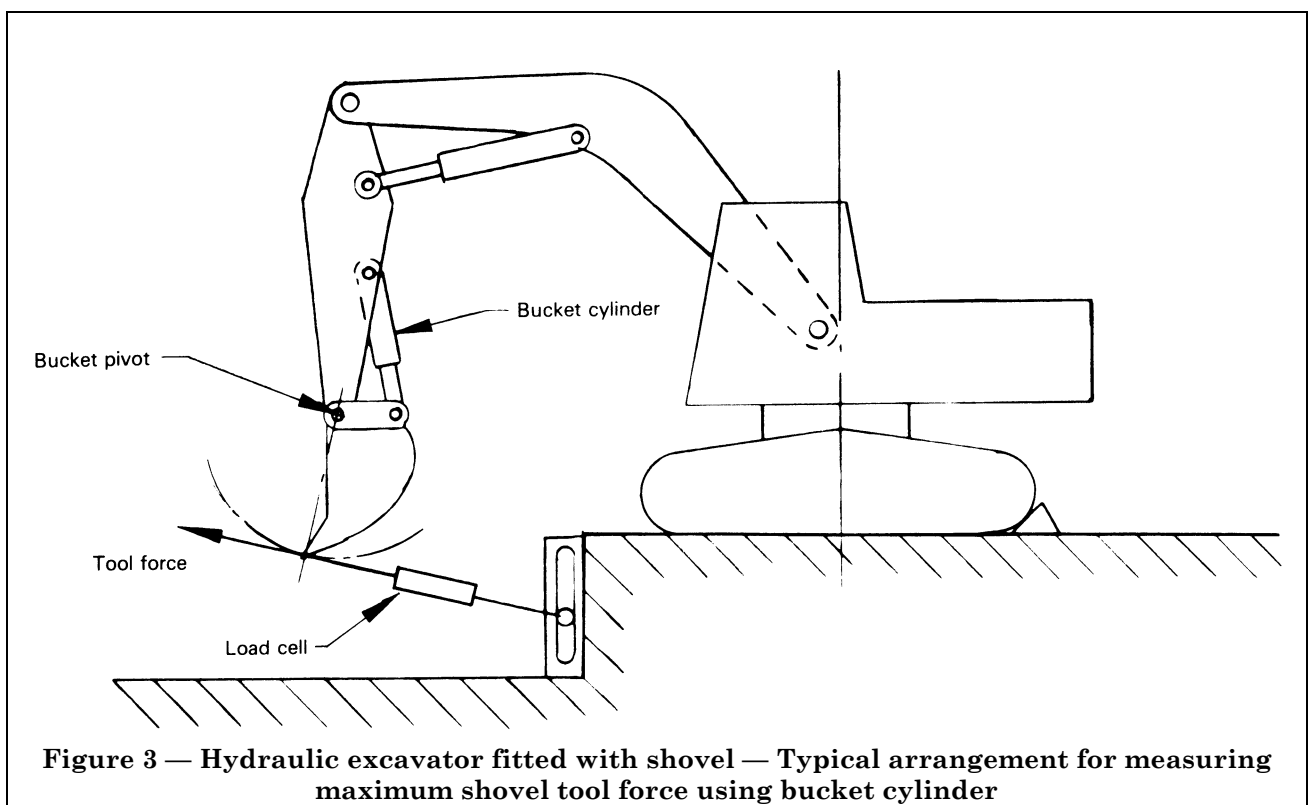
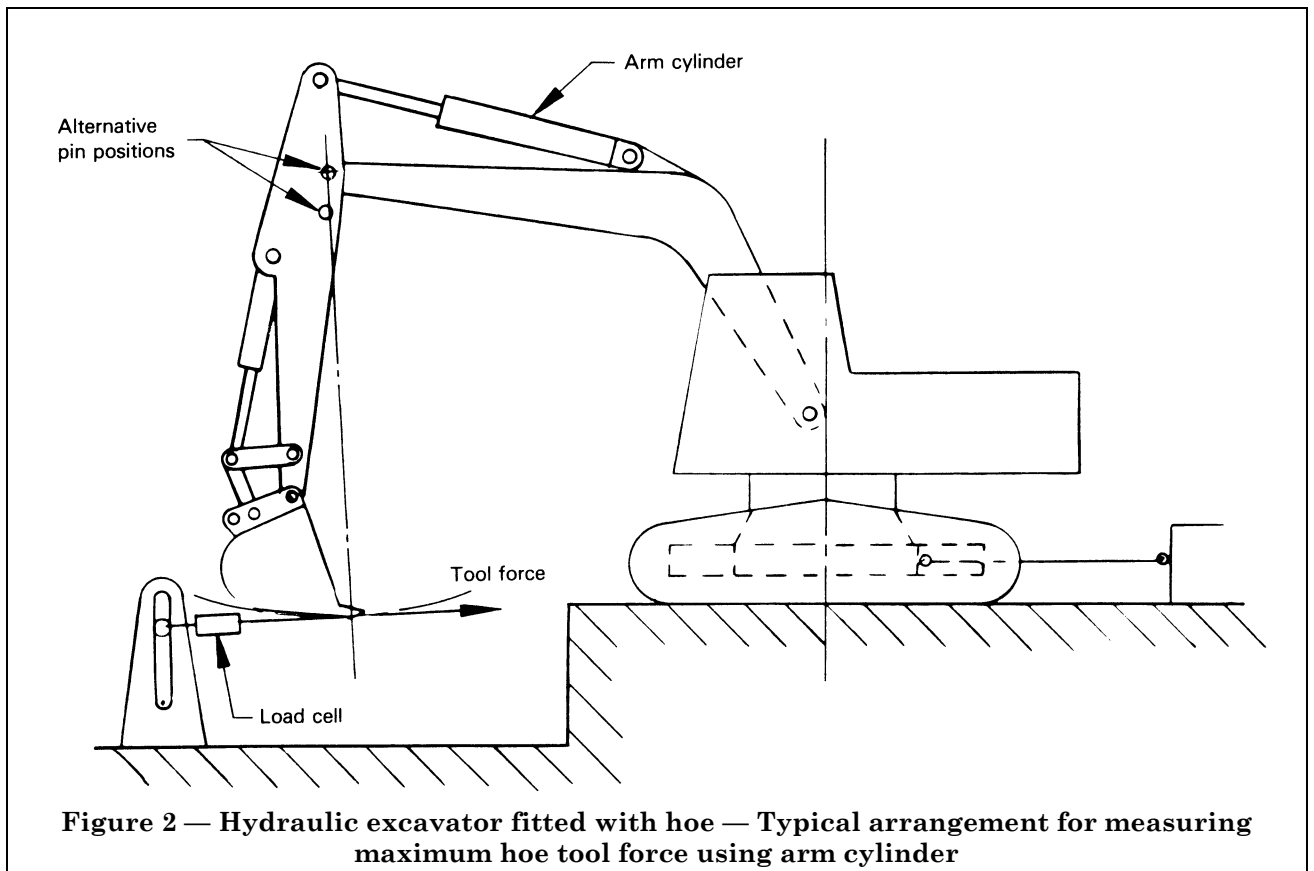

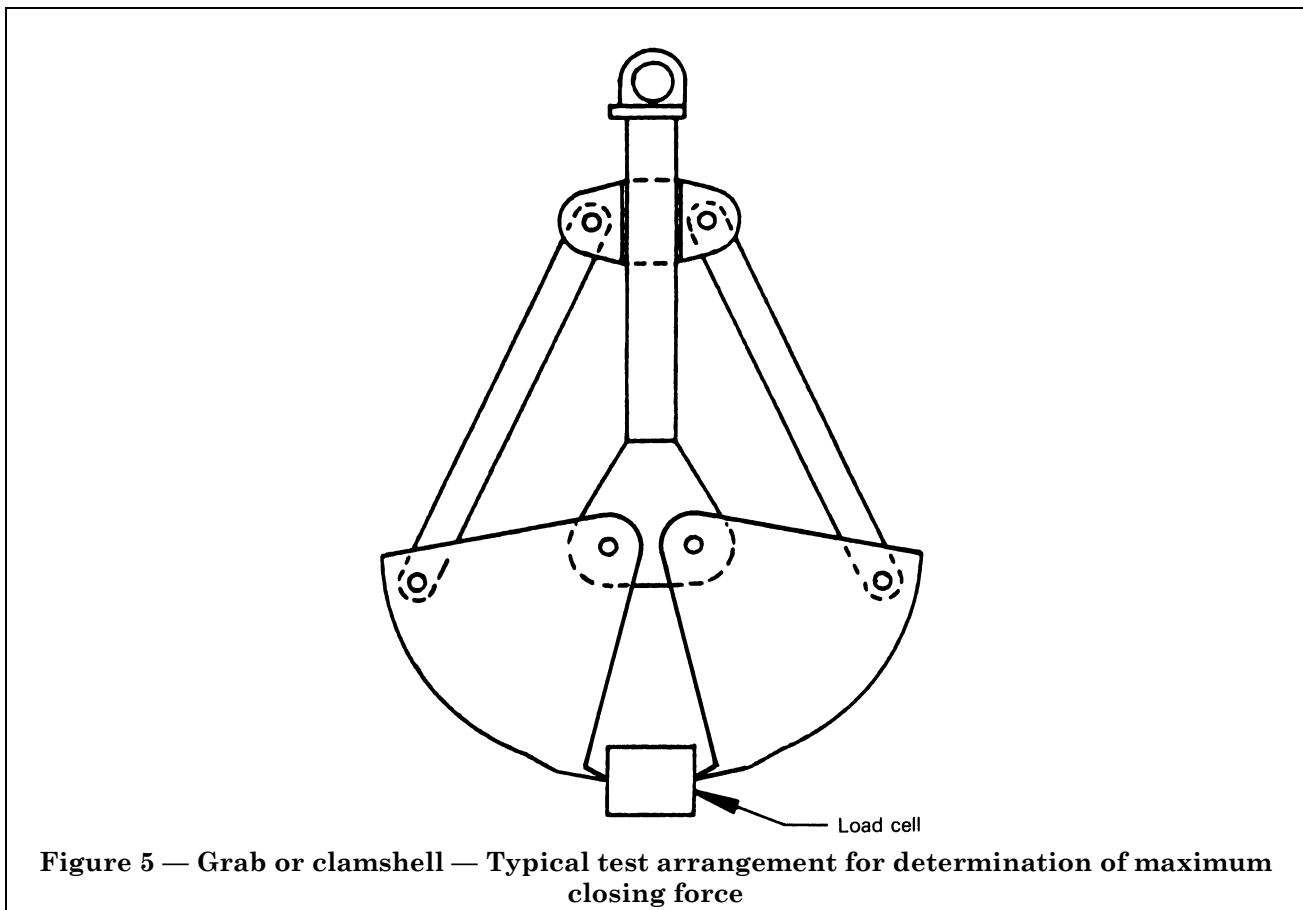
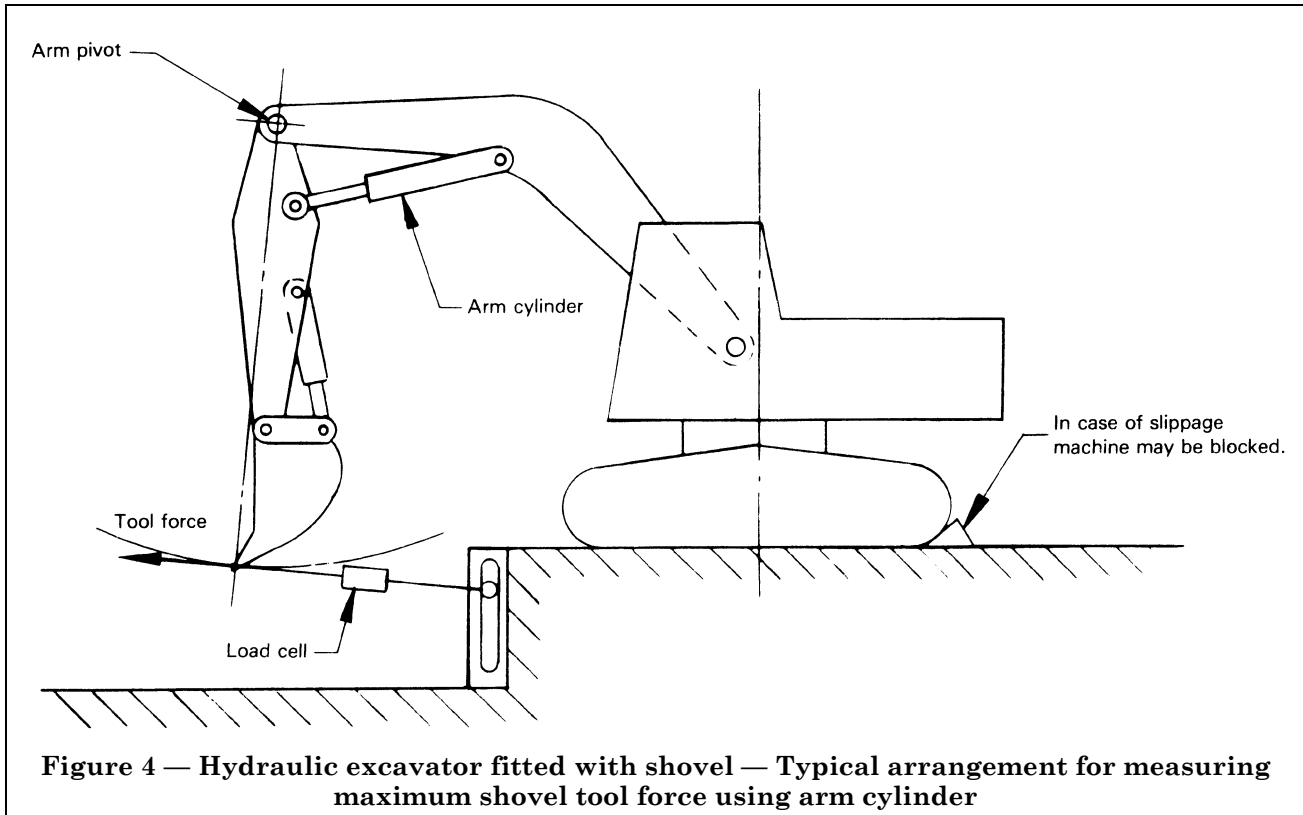

Publications referred to

See national foreword.

BSI — British Standards Institution

BSI is the independent national body responsible for preparing British Standards. It presents the UK view on standards in Europe and at the international level. It is incorporated by Royal Charter.

Revisions

British Standards are updated by amendment or revision. Users of British Standards should make sure that they possess the latest amendments or editions.

It is the constant aim of BSI to improve the quality of our products and services. We would be grateful if anyone finding an inaccuracy or ambiguity while using this British Standard would inform the Secretary of the technical committee responsible, the identity of which can be found on the inside front cover. Tel: 020 8996 9000. Fax: 020 8996 7400.

BSI offers members an individual updating service called PLUS which ensures that subscribers automatically receive the latest editions of standards.

Buying standards

Orders for all BSI, international and foreign standards publications should be addressed to Customer Services. Tel: 020 8996 9001. Fax: 020 8996 7001.

In response to orders for international standards, it is BSI policy to supply the BSI implementation of those that have been published as British Standards, unless otherwise requested.

Information on standards

BSI provides a wide range of information on national, European and international standards through its Library and its Technical Help to Exporters Service. Various BSI electronic information services are also available which give details on all its products and services. Contact the Information Centre. Tel: 020 8996 7111. Fax: 020 8996 7048.

Subscribing members of BSI are kept up to date with standards developments and receive substantial discounts on the purchase price of standards. For details of these and other benefits contact Membership Administration. Tel: 020 8996 7002. Fax: 020 8996 7001.

Copyright

Copyright subsists in all BSI publications. BSI also holds the copyright, in the UK, of the publications of the international standardization bodies. Except as permitted under the Copyright, Designs and Patents Act 1988 no extract may be reproduced, stored in a retrieval system or transmitted in any form or by any means – electronic, photocopying, recording or otherwise – without prior written permission from BSI.

This does not preclude the free use, in the course of implementing the standard, of necessary details such as symbols, and size, type or grade designations. If these details are to be used for any other purpose than implementation then the prior written permission of BSI must be obtained.

If permission is granted, the terms may include royalty payments or a licensing agreement. Details and advice can be obtained from the Copyright Manager. Tel: 020 8996 7070.