

Code of practice for protection of structures against lightning

ICS 91.120.40

Committees responsible for this British Standard

The preparation of this British Standard was entrusted to Technical Committee GEL/81, Protection against lightning, upon which the following bodies were represented:

Association of Consulting Engineers
BEAMA Electrical Cable and Conductor Accessory Manufacturers' Association
British Telecommunications plc
Council for the Care of Churches
Department of the Environment, Transport and the Regions
Electricity Association
Engineering Equipment and Materials Users Association
ERA Technology Ltd.
National Federation of Master Steeplejacks and Lightning Conductor Engineers
Ministry of Defence

This British Standard, having been prepared under the direction of the Electrotechnical Policy and Strategy Sector Committee, was published under the authority of the Standards Committee and comes into effect on 15 September 1999

© BSI 09-2000

The following BSI references relate to the work on this standard:
Committee reference GEL/81
Draft for comment 98/264818 DC

Amendments issued since publication

Amd. No.	Date	Comments
11076 Corrigendum No. 1	September 2000	See foreword

ISBN 0 580 33042 7

Contents

	Page
Committees responsible	Inside front cover
Foreword	iv
<hr/>	
Introduction	1
1 Scope	1
2 Normative references	1
3 Definitions and abbreviations	1
4 Technical aspects of lightning	3
5 Effects of lightning strike	5
6 Function of a lightning conductor	6
7 Materials	6
8 Dimensions	11
9 Basic considerations	12
10 Need for protection	12
11 Zone of protection	17
12 General considerations for system design	23
13 Consultation	23
14 Component parts	25
15 Air terminations	25
16 Down conductors	37
17 Earth termination network	45
18 Earth electrodes	46
19 Metal in or on a structure	48
20 Structures exceeding 20 m in height	57
21 Structures with roofs of high flammability	58
22 Buildings with explosive or highly flammable contents	58
23 Dwelling houses	63
24 Fences	63
25 Trees and structures near trees	66
26 Structures with radio and television aerials	67
27 Miscellaneous structures	67
28 Corrosion	71
29 Structures	72
30 Overhead power lines	72
31 Inspection	72
32 Testing	75
33 Records	75
34 Maintenance and upkeep	75
Annex A (informative) Explanatory notes on some of the recommendations of this code	76
Annex B (informative) Guidance on the application of BS 6651	81
Annex C (informative) General advice on protection against lightning of electronic equipment within or on structures	84
<hr/>	
Bibliography	117
Figure 1 — Lightning flash density to ground (N_g) per square kilometre per year for the British Isles	4
Figure 2 — Typical designs for lightning conductor fixings	7
Figure 3 — Map showing thunderstorm days per year throughout the world	14
Figure 4 — Details of structures and collection areas	20
Figure 5 — Examples of lightning protection systems for brick chimneys	21
Figure 6 — Protective angles and zones of protection for various forms of air termination	22

	Page
Figure 7 — Examples of air terminations and down conductors using handrails, metal copings and reinforcing bars	26
Figure 8 — Test joints	27
Figure 9 — Typical forms of vertical air terminations	28
Figure 10 — Air terminations for a flat roof	29
Figure 11 — Air terminations for flat roofs at different levels	30
Figure 12 — Air terminations for large areas of roof of various profiles	31
Figure 13 — Air terminations and concealed conductors for buildings less than 20 m high with sloping roofs	32
Figure 14 — Air terminations and down conductors for flat roof buildings	33
Figure 15 — Air terminations for tall conducting structures	34
Figure 16 — Air termination network with horizontal conductors for structure with explosive or highly flammable contents	35
Figure 17 — Air termination for a flat roof showing connection to standing seam joint when a metallic roof is used as part of the air termination network	36
Figure 18 — Air termination and zone of protection for simple structure with explosive or highly flammable contents	38
Figure 19 — Patterns of down conductors (natural or not) for various forms of tall building	41
Figure 20 — Voltage gradients along ground surface near to masts, towers and columns with single multiple earth electrodes (see 16.2 and A.1.2)	42
Figure 21 — Down conductor in internal duct	43
Figure 22 — Re-entrant loops	44
Figure 23 — Lightning protection system for tall buildings (over 20 m high) showing air terminations, down conductors, bonds to projections above roof	47
Figure 24 — Example of an earth electrode seal for use within a tanked structure	49
Figure 25 — Earth terminations: arrangement of earth electrodes	50
Figure 26 — Curve for determining the probable maximum current in the lightning flash from the ratio p/p_0	51
Figure 27 — Transfer inductance in simple loop	52
Figure 28 — Curve for determination of flashover voltage as function of spacing	55
Figure 29 — Plan of collection area	55
Figure 30 — Diagram showing bonding to services (gas, water and electricity)	57
Figure 31 — Church towers and spires	59
Figure 32 — Air termination with twin suspended horizontal conductor and zone of protection for structures with explosive or highly flammable contents	60
Figure 33 — Vertical air termination for protection of explosive stores	61
Figure 34 — Exceptional protection against overvoltages induced by lightning in incoming supplies to buildings with explosive or highly flammable contents	64
Figure 35 — Lightning protection for domestic properties	65
Figure 36 — Lightning protection for tents	68
Figure 37 — Lightning protection (low cost installation) for isolated farm buildings of brick and tile construction	69
Figure 38 — Lightning protection system for sports stadium (football ground)	70
Figure 39 — Typical arrangement for protection of windmills	73
Figure 40 — Bridges	74
Figure A.1 — Examples of use of the “rolling sphere method” for assessing a tall complex building for regions where air terminations are needed	80
Figure C.1 — Strike location points to industrial installations which could affect electronic systems	99
Figure C.2 — Configurations involving electronic equipment	87
Figure C.3 — Lightning current distribution in a fifteen stanchion building	88

	Page
Figure C.4 — Plan view of fifteen stanchion building showing resulting field line plot (transfer inductance contours) for lightning pulse	89
Figure C.5 — Collection area of structure and adjacent associated structure	93
Figure C.6 — Cables entering a building separated from a transmitter mast	96
Figure C.7 — Bonding of cables and pipes at entry and exit to buildings	97
Figure C.8 — Methods of reducing induced voltages	100
Figure C.9 — Hybrid earth system applied to equipment in multi-floor building	101
Figure C.10 — Earth connection from zero voltage reference of equipment to earth of surge protection devices	102
Figure C.11 — Direct injection into exposed electrical systems	104
Figure C.12 — Protection from direct injection	104
Figure C.13 — Protection of cables located alongside tall vessels and bonding at roof level	105
Figure C.14 — Locations where high, medium or low lightning current can be expected to flow through cables associated with a reaction vessel	106
Figure C.15 — Lightning current characteristics for severe negative strike	107
Figure C.16 — Strike points on plant	108
Figure C.17 — Inductance	115
Figure C.18 — Simplified circuit diagram of the combination wave generator	115
Figure C.19 — Waveshape of open circuit voltage (1.2/50 μ s)	116
Figure C.20 — Waveshape of short circuit current (8/20 μ s)	116
Table 1 — Recommended fixing centres for conductors	6
Table 2 — Recommended materials for the manufacture of earthing components	8
Table 3 — Some characteristics of typical materials listed in Table 2	10
Table 4 — Minimum dimensions of component parts	11
Table 5 — Minimum thicknesses of sheet metal used for roofing and forming part of the air termination network	12
Table 6 — Relationship between thunderstorm days per year and lightning flashes per square kilometre per year	13
Table 7 — Comparative probability of death for an individual per year of exposure (order of magnitude only)	15
Table 8 — Weighting factor <i>A</i> (use of structure)	15
Table 9 — Weighting factor <i>B</i> (type of construction)	16
Table 10 — Weighting factor <i>C</i> (contents or consequential effects)	16
Table 11 — Weighting factor <i>D</i> (degree of isolation)	16
Table 12 — Weighting factor <i>E</i> (type of terrain)	16
Table 13 — Examples of calculations for evaluating the need for protection	18
Table A.1 — Relationship between diameter and mass of electrodes	76
Table C.1 — Effective collection area of mains services	90
Table C.2 — Effective collection area of data lines	91
Table C.3 — Weighting factor <i>F</i> (type of construction)	91
Table C.4 — Weighting factor <i>G</i> (degree of isolation)	91
Table C.5 — Weighting factor <i>H</i> (type of terrain)	91
Table C.6 — Classification of structures and contents	92
Table C.7 — Classification of exposure level	92
Table C.8 — Location category A (mains)	112
Table C.9 — Location category B (mains)	112
Table C.10 — Location category C (mains)	112
Table C.11 — Location category C (data lines)	113
Table C.12 — Definitions of the waveshape parameters 1.2/50 μ s	114

Foreword

This British Standard has been prepared by Technical Committee GEL/81 and supersedes BS 6651:1992, which is withdrawn.

Some of the changes introduced since the publication of the previous edition include:

- the provision of a new lightning flash density map (Figure 1), compiled from data accumulated over the last ten years;
- a simple calculation, based on IEC findings, relating to buildings with cantilevered upper floors and the risk of side flashing from external down conductors to persons standing under the overhang;
- modifications to Figure 13 to clarify the positioning of air terminals on buildings with sloping roofs;
- modifications to Figure 28 to give additional information relating to flashover voltage through cracks in mortar and brickwork.

Corrigendum No. 1 (September 2000) makes corrections to the following:

- Figure 1; Table 1, last row; Table 9, row 3;
- Table 10, title and heading of column 1; Table 13, rows a) and f);
- Figure 13a, diagram 3; **19.2.1.4** equation in example of use of equation (6);
- 19.3.9** (deletion of last three paragraphs); **27.7** item a).

The principle informing all the provisions of this British Standard is that of the “Faraday cage” form of lightning protection. The Technical Committee is aware of development and research on other technologies in the field of lightning protection that has been taking place in recent years, but it is the Committee’s considered opinion that the materials, extent and dimensions of the air terminations, down conductors, earth terminations, bonding, components, etc. as laid down in this code of practice be adhered to in full, irrespective of any devices or systems employed which are claimed to provide enhanced protection.

This standard is intended to provide guidance on the principles and practice that experience has shown to be important in protecting structures against damage from lightning. It examines the characteristics of the lightning phenomenon and indicates the statistical nature of the evidence on which assessments for protection are based. Guidance is also provided on the need for protection for structures in general and for specific structures that are considered to be most at risk; these recommendations are an economic compromise between absolute protection and the cost of the installation.

The protection of electronic equipment against lightning continues to be the subject of standardization work in the international and European Standards fora. However, until definitive European Standards are available for adoption as British Standards, the Technical Committee maintains the general advice on the subject which is given in annex C.

As a code of practice, this British Standard takes the form of guidance and recommendations. It should not be quoted as if it were a specification and particular care should be taken to ensure that claims of compliance are not misleading.

WARNING Attention is drawn to the danger of installing or carrying out maintenance work on lightning protection systems or surge protection devices during a storm.

A British Standard does not purport to include all the necessary provisions of a contract. Users of British Standards are responsible for their correct application.

Compliance with a British Standard does not of itself confer immunity from legal obligations.

Summary of pages

This document comprises a front cover, an inside front cover, pages i to iv, pages 1 to 118, an inside back cover and a back cover.

The BSI copyright notice displayed in this document indicates when the document was last issued.

Introduction

Lightning is a natural hazard, being the discharge of static electricity generated in parts, called “cells”, of storm clouds. In the UK, about one million flashes strike the ground each decade. Some lightning flashes damage buildings and a few kill or injure people and animals, either directly or indirectly by causing fire and explosions. Statistics for deaths by lightning show the risk to be very low, being one in two million per year (see **10.3**).

This British Standard outlines the general technical aspects of lightning, illustrating its principal electrical, thermal and mechanical effects. Guidance is given on how to assess the risk of being struck and how to compile an index figure as an aid to deciding whether a particular structure is in need of protection.

The guidance given is of a general nature and its application to specific lightning protection installations has to take into account the particular conditions pertaining to those installations. In cases of difficulty, specialist advice should be sought.

It is emphasized that even where protection is provided it can never be completely effective in eliminating the risk of damage to the structure.

NOTE 1 Some explanatory information about the recommendations of this standard is given in annex A.

NOTE 2 All structures shown in figures are “typical” only and are not intended as designs.

NOTE 3 Guidance on the application of the standard is given in annex B.

NOTE 4 General advice on the protection of electronic equipment against lightning is given in annex C.

1 Scope

This British Standard provides guidance on the design of systems for the protection of structures against lightning and on the selection of materials. Recommendations are made for special cases such as explosives stores and temporary structures, e.g. cranes and spectator stands constructed of metal scaffolding. Guidance is also given on the protection of electronically stored data.

The principle informing all the provisions of this British Standard is that of the “Faraday cage” form of lightning protection, and installations employing alternative technologies fall outside the scope of this British Standard.

Protection of offshore oil and gas installations does not fall within the scope of this British Standard.

NOTE Where current-carrying conductors are directly associated with structures lying within the scope of this code of practice, certain recommendations relating to them are included; however, the protection of radar stations, overhead telephone wires, electric traction and supply lines should, on account of their special nature, be determined by the appropriate authorities.

2 Normative references

The following normative documents contain provisions which, through reference in this text, constitute provisions of this British Standard. For dated references, subsequent amendments to, or revisions of, any of these publications do not apply. For undated references, the latest edition of the publication referred to applies.

BS 729, *Specification for hot dip galvanized coatings on iron and steel articles*.

BS 5970, *Code of practice for thermal insulation of pipework and equipment in the temperature range $-100\text{ }^{\circ}\text{C}$ to $+870\text{ }^{\circ}\text{C}$* .

BS 6330, *Code of practice for reception of sound and television broadcasting*.

BS 7430, *Code of practice for earthing*.

BS 7671, *Requirements for electrical installations — IEE Wiring regulations — Sixteenth edition*.

BS EN 50020, *Electrical apparatus for potentially explosive atmospheres — Intrinsic safety “i”*.

3 Definitions and abbreviations

3.1 Definitions

For the purposes of this British Standard, the following definitions apply.

3.1.1

lightning flash

electrical discharge between cloud and earth, of atmospheric origin, comprising one or more impulses of many kiloamps

3.1.2

lightning stroke

one of the single distinguishable current impulses of a lightning flash

3.1.3

lightning strike

lightning flash attaching to a structure

3.1.4

lightning protection system

whole system of conductors used to protect a structure from the effects of lightning

3.1.5

air termination network

that part of a lightning protection system which is intended to intercept lightning discharges

NOTE The term “air termination” may be used in an equivalent sense.

3.1.6

down conductor

conductor that connects an air termination with an earth termination (see **3.1.10**)

3.1.7**bond**

conductor intended to provide electrical connection between the lightning protection system and other metalwork and between various portions of the latter

3.1.8**joint**

mechanical and/or electrical junction between two or more portions of a lightning protection system

3.1.9**test joint**

joint designed and situated so as to enable resistance or continuity measurements to be made

3.1.10**earth termination network**

that part of a lightning protection system which is intended to discharge lightning currents into the general mass of the earth

NOTE 1 All points below the test points in down conductors are included in this term.

NOTE 2 The term "earth termination" may be used in an equivalent sense.

3.1.11**earth electrode**

conductive part which is intended to conduct lightning current, or a group of conductive parts in intimate contact with and providing an electrical contact with the earth

NOTE It may comprise, for example, one or more driven rods, horizontal conductors or reinforced concrete foundations.

3.1.12**ring earth electrode**

earth electrode forming a closed loop round the structure below or on the surface of the earth, or within or under the foundations

NOTE A ring earth electrode may be used to interconnect other earth electrodes.

3.1.13**indicating plate**

plate detailing the number and position of earth electrodes

3.1.14**reference earth electrode**

earth electrode capable of being completely isolated from an earth termination network for use in periodic testing

3.1.15**isolation**

positioning of metal in and on a structure relative to the lightning protection system so that the metal is not required to carry any part of the lightning current

3.1.16**log book**

record of tests and inspections of a lightning conductor installation

3.1.17**electronic equipment**

communications equipment, telemetry, computer, control and instrumentation systems and power electronic installations and similar equipment incorporating electronic components

3.1.18**equipment transient design level (ETDL)**

level of transients to which a piece of equipment has been satisfactorily tested

NOTE ETDL is sometimes known as "immunity level".

3.1.19**transient control level (TCL)**

maximum level of transients occurring in a protected system, achieved by design of protection (screening etc.) or by use of surge suppressors

3.1.20**self-inductance**

property of a wire or circuit which causes a back e.m.f. to be generated when a changing current flows through it

NOTE 1 The self-inductance of a wire or circuit produces a back e.m.f. which is given by:

$$V = L \cdot \frac{di}{dt}$$

where

V is the back e.m.f. in volts (V);

L is the self-inductance in henries (H);

$\frac{di}{dt}$ is the rate of change of current in amperes per second (A/s).

NOTE 2 See C.9.2.

3.1.21**mutual inductance**

property of a circuit whereby a voltage is induced in a loop by a changing current in a separate conductor

NOTE 1 The mutual inductance of a loop produces an induced voltage given by:

$$V = M \cdot \frac{di}{dt}$$

where

V is the induced voltage in a loop in volts (V);

M is the mutual inductance in henries (H);

$\frac{di}{dt}$ is the rate of change of current in a separator conductor in amperes per second (A/s).

NOTE 2 See C.9.2.

3.1.22**transfer inductance**

property of a circuit whereby a voltage is induced in a loop by a changing current in another circuit, some part of which is included in the loop

NOTE 1 The transfer inductance of a loop produces an induced voltage given by:

$$V = M_T \cdot \frac{di}{dt}$$

where

V is the induced voltage in a loop in volts (V);

M_T is the transfer inductance in henries (H);

$\frac{di}{dt}$ is the rate of change of current in another circuit in amperes per second (A/s).

NOTE 2 See C.9.2.

3.1.23**lightning electromagnetic pulse (LEMP)**

voltages or currents induced into cables and other conductors by the radiated field from a lightning flash some distance away

NOTE LEMPs may be undesirable in electronic systems, but rarely cause transients of high voltage or high energy.

3.1.24**common mode (CM)**

voltage common to all conductors of a group as measured between that group at a given location and an arbitrary reference (usually earth)

NOTE Common mode is sometimes known as "longitudinal mode".

3.1.25**differential mode (DM)**

voltage at a given location between two conductors of a group

NOTE Differential mode is sometimes known as "transverse mode".

3.1.26**local area network (LAN)**

data communications system supporting layers 1 and 2 of the ISO Reference Model for Open Systems Interconnections, having a geographic coverage up to 1 km end-to-end and possessing sufficient performance to support the aggregate data throughput required by the stations (data terminal equipment) being used

3.1.27**let-through voltage**

maximum peak voltage occurring within 100 μ s of application of the test wave

3.1.28**data line**

cable carrying information as distinct from power

NOTE Examples of data lines are telephone lines, telemetry control and signal lines.

3.1.29**return stroke**

part of the flash in which a charged cell in a thundercloud is discharged to earth

3.1.30**zone of protection**

volume within which a lightning conductor gives protection against a direct lightning strike by directing the strike to itself

3.2 Abbreviations

The following abbreviations are used in the figures of this British Standard:

DC Down conductor

GL Ground level

HC Horizontal conductor

VC Vertical conductor

ZP Zone of protection and protective angles

NOTE The boundary of a zone of protection is indicated in the figures by dashed lines.

4 Technical aspects of lightning**4.1 General**

Lightning activity varies over the UK with more flashes in the East than in the West and more in the South than in the North. Furthermore, there is a variation of roughly 2:1 over a period of about 11 years, which corresponds with the sunspot cycle. A diagrammatic representation of the density of lightning flashes to ground is shown in Figure 1.

The first step in minimizing the danger from lightning is to learn as much as possible about its nature. The main characteristics are therefore briefly summarized in 4.2.

4.2 Characteristics of lightning**4.2.1 Current in a lightning stroke**

Rather than describe an "average" lightning flash, it is easier to give ranges for the various parameters. The important part of a lightning flash with regard to the resulting damage is the return stroke. The current in this return stroke ranges from about 2 000 A to about 200 000 A and its distribution of values is of the form which occurs frequently in nature, the so-called "log normal" distribution, as follows:

- 1 % of strokes exceed 200 000 A;
- 10 % of strokes exceed 80 000 A;
- 50 % of strokes exceed 28 000 A;
- 90 % of strokes exceed 8 000 A;
- 99 % of strokes exceed 3 000 A.

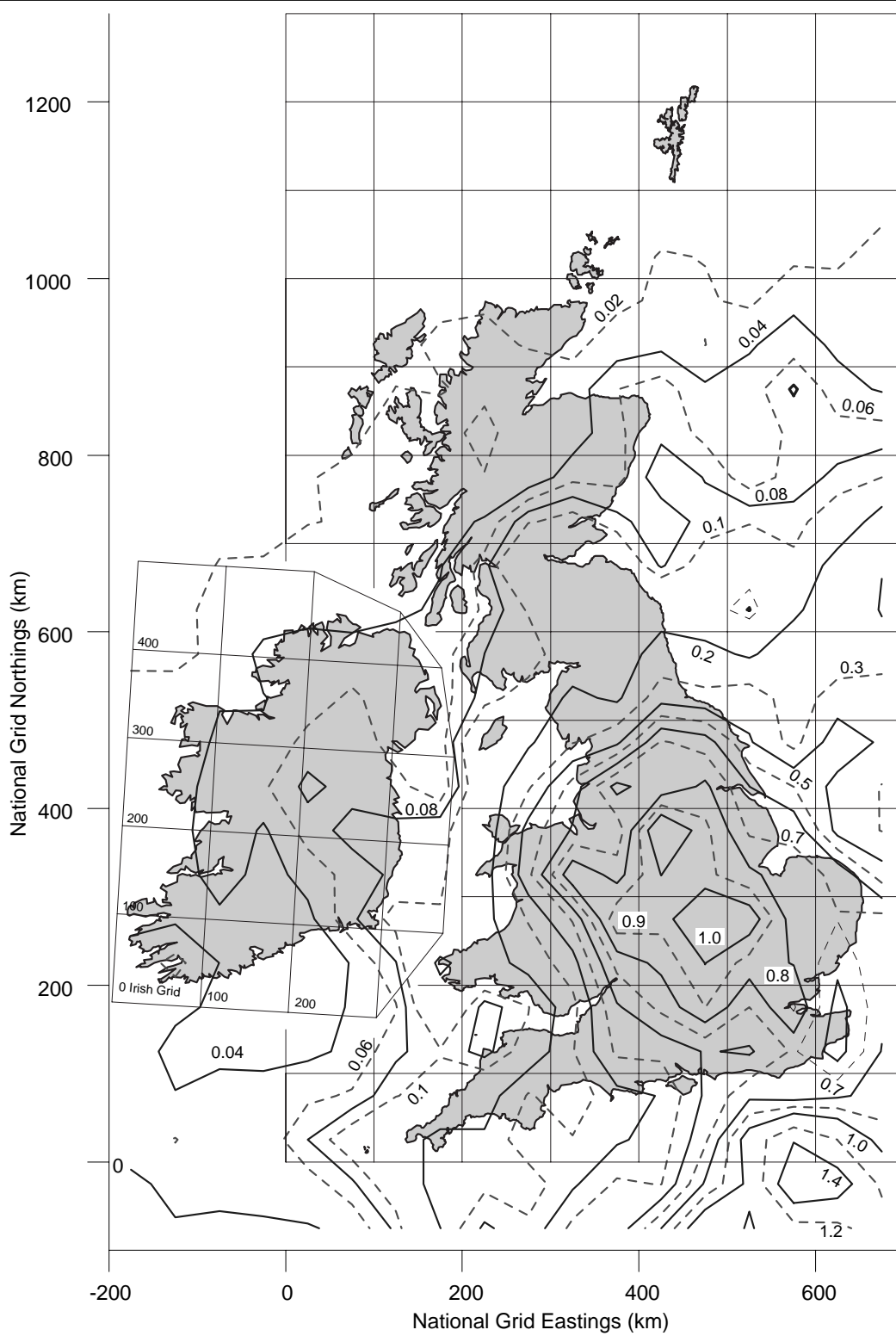

NOTE 1 This lightning density map was compiled by E.A. Technology Ltd. from data accumulated over 10 years.

NOTE 2 A linear interpolation should be used to determine the value of the lightning flash density, N_g , for a location between two contour lines.

Figure 1 — Lightning flash density to ground (N_g) per square kilometre per year for the British Isles

The current in most ground flashes is from the negatively charged cells in the thundercloud and the flash current is therefore a negative flow from cloud to ground; less frequently, strokes from a positive part of the cloud also occur. For either polarity, however, the current flow is unidirectional with a rise time of less than 10 μs for the negative flash (but considerably longer for the positive flash) and then a decay to a low value, for a simple single stroke, in 100 μs or less.

Some flashes comprise two or more strokes which individually conform to the description for a single stroke but which may be spaced in time 50 ms to 100 ms apart. Rare multi-stroke flashes, which have more than 10 strokes, may therefore last for up to 1 s.

For the purposes of lightning protection system design, the following values of peak lightning current (i_{max}) and rate of rise of lightning current are considered to be the most severe:

$$i_{\text{max}} = 200 \text{ kA}$$

$$\left(\frac{di}{dt}\right)_{\text{max}} = 200 \text{ kA}/\mu\text{s}$$

4.2.2 Voltage

Before the flash takes place, the potential of the charge cell may be estimated very roughly by assuming the charge Q in the cell to be 100 C and the radius of an equivalent spherical cell to be 1 km. The capacitance C of the cell is therefore about 10^{-7} F and, from $Q = CV$, the potential V is estimated to be 10^9 V. It is reasonable therefore to assume that the cloud potential is more than 100 MV. This value is high enough to ensure that the potential of whatever is struck will be controlled by the product of current and impedance, because this will never be high enough in comparison with the cloud potential to modify the current magnitude.

Although the return stroke is the most important pulse of a lightning stroke, it is necessary to know something of the process which precedes it in order to understand why high structures are more vulnerable than low ones. The lightning stroke is preceded by a downward leader which makes a step-by-step descent of some tens of metres at a time from the cloud. When the last step brings the tip of the leader sufficiently close to earth, an upward leader leaves the earth to join the tip of the downward leader, so establishing a conductive channel for the main current to flow.

The initiation of this upward leader depends on a critical field being exceeded at the earth emission point and so is a function of the charge deposited by the down-coming leader and any enhancement of the field caused by the geometry of the earth. The length of the upward leader will be greater for greater charges and hence high current flashes will start preferentially from high structures for which the field enhancement is high.

5 Effects of lightning strike

5.1 Electrical effects

As the current is discharged through the resistance of the earth electrode of the lightning protection system, it produces a resistive voltage drop which may momentarily raise the potential of the protection system to a high value relative to true earth. It may also produce around the earth electrode a high potential gradient dangerous to people and animals. In the same general manner, the inductance of the protection system also has to be considered because of the steep leading edge of the lightning pulse.

The resulting voltage drop in the protection system is therefore the arithmetic sum of the resistive and inductive voltage components.

5.2 Side-flashing

The point of strike on the protection system may be raised to a high potential with respect to adjacent metal. There is therefore a risk of flashover from the protection system to any other metal on or in the structure. If such flashover occurs, part of the lightning current is discharged through internal installations, such as pipes and wiring, and therefore constitutes a risk to the occupants and the fabric of the structure.

5.3 Thermal effects

For the purposes of lightning protection, the thermal effect of a lightning discharge is confined to the temperature rise of the conductor through which the current passes. Although the current is high, its duration is short and the thermal effect on the protection system is usually negligible.

NOTE This ignores the fusing or welding effects on damaged conductors or those which were not adequate on initial installation.

In general, the cross-sectional area of a lightning conductor is chosen primarily to satisfy the requirements for mechanical strength, which means that it is large enough to keep the rise in temperature to 1 °C. For example, with a copper conductor of 50 mm² cross-section, a severe stroke of 100 kA with a duration of 100 μs dissipates less than 400 J per metre of conductor, resulting in a temperature rise of about 1 °C. The substitution of steel for copper results in a rise of less than 10 °C.

5.4 Mechanical effects

Where a high current is discharged along parallel conductors in close proximity or along a single conductor with sharp bends, considerable mechanical forces are produced. Secure mechanical fittings are therefore essential (see Figure 2 and Table 1).

A different mechanical effect exerted by a lightning flash is due to the sudden rise of 30 000 K in the air temperature and the resulting explosive expansion of the adjacent air in the channel along which the

charge is propagated. This is because, when the conductivity of the metal is replaced by that of an arc path, the energy increases about one hundred-fold. A peak power of about 100 MW/m can be attained in the return stroke and the shock wave close to this stroke can readily dislodge tiles from a roof.

Similarly, with a side-flash inside the building, the shock wave can result in damage to the building fabric.

6 Function of a lightning conductor

A lightning conductor is incapable of discharging a thundercloud without a lightning flash. Its function is to divert to itself a lightning discharge, which might otherwise strike a vulnerable part of the structure to be protected, and to convey the current safely to earth. The range over which a lightning conductor can attract a lightning flash is not constant but it is now believed to be a function of the severity of the discharge. The range of attraction is therefore a statistical quantity.

On the other hand, the range of attraction is little affected by the configuration of the conductor, so that vertical and horizontal arrangements are equivalent. The use of pointed air terminations or vertical finials is therefore not regarded as essential, except where dictated by practical considerations.

Table 1 — Recommended fixing centres for conductors

Arrangement	Fixing centres mm
Horizontal conductors on horizontal surfaces	1 000
Horizontal conductors on vertical surfaces	500
Vertical conductors from the ground to 20 m	1 000
Vertical conductors from 20 m and thereafter	500
NOTE 1 This table does not apply to built-in type fixings which may require special consideration.	
NOTE 2 Assessment of environmental conditions should be undertaken and fixing centres different from those recommended may be found to be necessary.	

7 Materials

Table 2 gives some recommendations for materials to be used in the manufacture of the component parts of lightning protection systems. Characteristics for some of these materials are given in Table 3.

Copper and aluminium are recommended for installations required to have a long life. If there is any difficulty in the use of copper or aluminium, galvanized steel of the same cross-section as that recommended for copper may be used; galvanized steel may actually be preferred for some short life installations, e.g. exhibitions.

In making a choice, consideration should always be given to the risk of corrosion, including galvanic corrosion. General advice on this subject may be found in BS 5493 and DD 24.

For the protection of conductors, due consideration should be given to protective coatings to prevent corrosion in less-favourable environments, as in the following examples.

a) Covering the conductor with lead (2 mm minimum thickness of coating) is the most suitable form of protection at the top of chimneys. Lead sheathing should be sealed at both ends and the sheathing should not be removed when making joints.

b) Where possible, for maximum effectiveness, air terminations should be formed from bare conductors. Where this is not possible, for example for aesthetic reasons or because corrosion of unprotected metal (particularly aluminium) is expected, a thin (1 mm thick) PVC coating or paint may be used.

When non-metallic fixing materials are used, their possible degradation due to ultraviolet light, frost, etc., should be borne in mind and the advantages of easy installation and absence of electrogalvanic corrosion set alongside the possible need to replace the fixings more frequently.

Although in the past it has been common practice to use material in the form of a strip for horizontal air terminations, down conductors and bonds, it may sometimes be more convenient to use rod material, particularly as it facilitates the introduction of bends in any plane.

Internal bonds may have approximately half the cross-sectional area of external bonds (see **16.10.2**). Flexible bonds may be used and should then conform to the requirements of BS 6360.

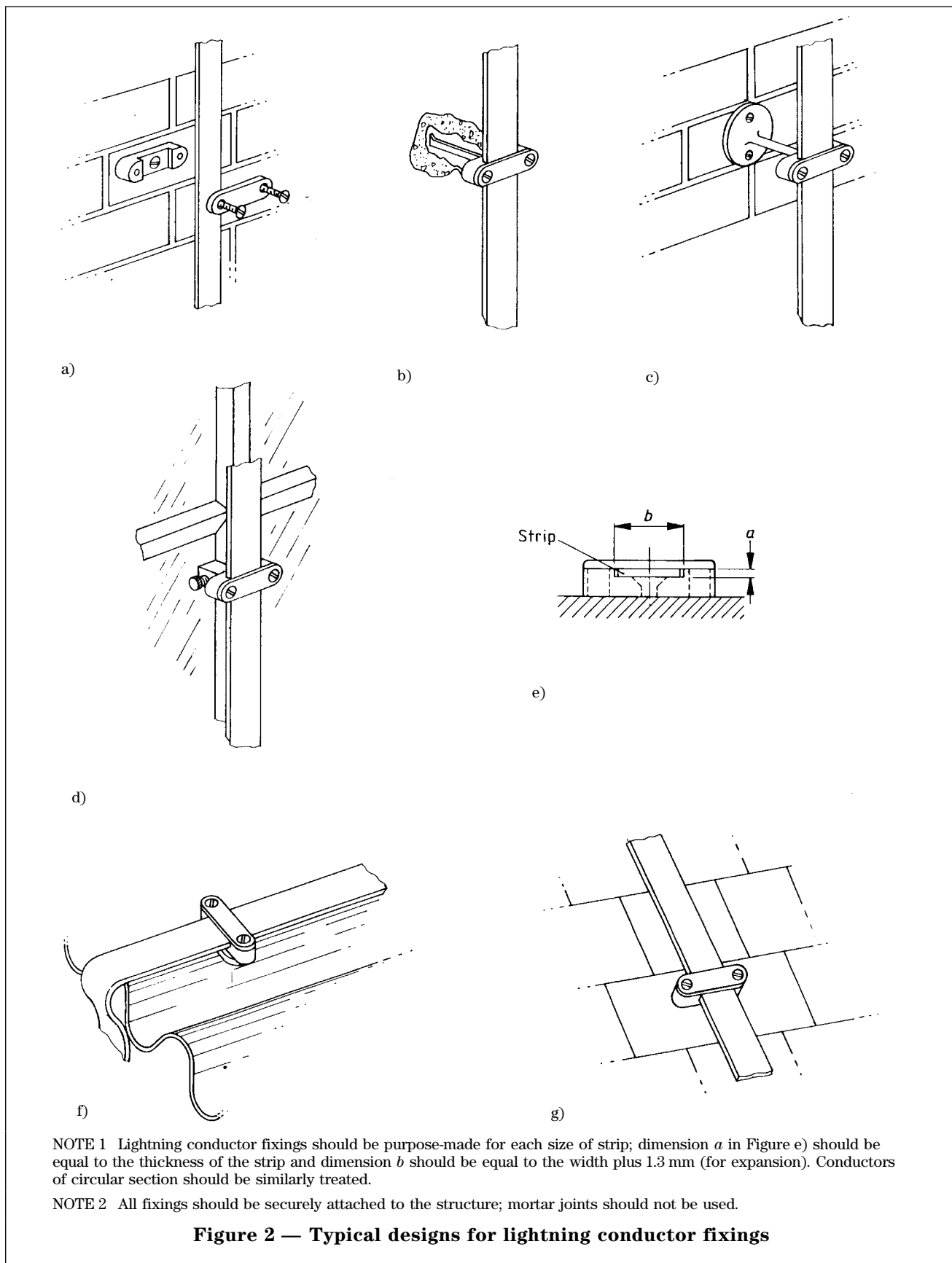

Table 2 — Recommended materials for the manufacture of lightning protection components

Materials and processes	BS number	BS grade or type	BS EN number	BS EN designation
Ingots for cast components				
Leaded gunmetal	1400	LG1, LG2		
Aluminium silicon bronze	1400	AB3, AB1		
Aluminium alloy	1490	LM6M, LM25		
Cast iron			EN 1561	
Malleable iron			EN 1562	
Forgings and stampings (hot or cold formed)				
Copper	2872	C101, C102, C103, C106	12165, prEN 12420	CW003A, CW004A, CW005A, CW008A, CW024A
Naval brass	2872	CZ112		
Aluminium	1474	6082-TF	586-2	EN AW-6082-T6
Steel	970-1	All grades		
Pressings and fabrications (from strip, coil, foil and sheet)				
Annealed copper	2870	C101, C102, C103, C104, C106	1172, 1652, 1653, 1654	CW003A, CW004A, CW005A, CW008A, CW024A, CW006A
Aluminium	1474	6082-TF	485-2	EN AW-6082-T6
Naval brass	2870	CZ112		
Stainless steel	1449-2	316S12, 325S21		
Steel (for galvanizing)	1449-1		10025	Fe430A
Bars, rods and tubes (for machined components and fittings)				
Copper, hard drawn or annealed	2871, 2874	C101, C102, C103, C106	12163, 12164, 12167	CW003A, CW004A, CW005A, CW008A, CW024A
Copper silicon	2871, 2874	CS101	12163, 12164, 12167	CW451K
Phosphor bronze	2871, 2874	PB102M	12163, 12164, 12167	CW116C
Aluminium bronze	2871-3	CA102		
Aluminium	1474	6082-TF	755-2	
Naval brass	2874	CZ112		
Steel (for general use)	970	All grades		
Steel (for galvanizing)	970	All grades		
Stainless steel (general use)	970-1	325S31		
Stainless steel (austenitic)	970-1	325S11		
Nuts, bolts, washers, screws, rivet fixings and internal dowels in earth rods				
For use on copper:				
phosphor bronze	2874	PB102M	12163, 12164, 12167	CW451K
naval brass	2874	CZ112, CZ132		
copper silicon	2874	CS101	12163, 12164, 12167	CW116C
For use on aluminium:				
aluminium alloy	1473	6082-T6		
stainless steel	3111-2			
galvanized steel ^a	3111-1			

Table 2 — Recommended materials for the manufacture of lightning protection components
(continued)

Materials and processes	BS number	BS grade or type	BS EN number	BS EN designation
<i>Solid rounds, flats and stranded conductors</i>				
Copper:				
annealed copper	1432	C101, C102, C103		
hard drawn copper	1433	C101, C102, C103		
stranded	6360	Insulated		
flexible	6360			
hard-drawn copper	7884			
strand and copper cadmium	2873	C108		
Aluminium:				
aluminium strip/rod	2898	1350, 6101A		
aluminium	3988	Insulated		
aluminium (steel reinforced)	215-2			
aluminium alloy	2898			
Steel:				
galvanized steel ^a	3242			
	215-1			
galvanized strip ^a	302-2			
	1449-1			
^a The recommended finish is galvanized which has to be done in accordance with BS 729, after manufacture or fabrication. NOTE 1 Some of the BS standards and designations listed in this table are likely to be superseded by their European equivalents during the life of this British Standard. For current information please contact the Technical Information Group at BSI. NOTE 2 Stainless steel in contact with aluminium or aluminium alloys is likely to cause additional corrosion to the latter materials (see PD 6484). It is therefore important to take protective measures such as the use of inhibitors. NOTE 3 Copper alloys, other than those listed above, are permissible as long as they have a minimum copper content of 75 % and similar tensile properties				

Table 3 — Some characteristics of typical materials listed in Table 2

Material		General comments	Corrosion resistance ^b			Typical mechanical and electrical properties ^c									Electrical resistivity $\Omega \cdot m \times 10^{-8}$	Density kg/m ³
Grade ^a	Type		Rural	Industrial	Marine	0.1 % proof stress N/mm ²			Ultimate tensile strength N/mm ²			Elongation %				
						a	h	m	a	h	m	a	h	m		
1350	Aluminium	Good electrical conductor, ductile and easily bent	A	B	A	—	—	31	—	—	60	—	—	25	2.8	2 703
6101A	Aluminium	Good electrical conductor, fairly rigid compared to grade 1350 and may require heating to make sharp bends	B	B	B	—	180 ^d	—	—	210 ^d	—	—	10 ^d	—	3.1	2 700
6082	Aluminium alloy	Electrical conductivity not as good as grades 1350 or 6101A and not as commonly used but is a stronger conductor than grades 1350 or 6101A	B	C	B	—	270 ^e	—	—	310 ^d	—	—	9 ^d	—	3.6	2 700
C101	Annealed copper	Excellent electrical conductors with high ductility	A	A	A	60	325	—	220	385	—	55	4	—	1.7	8 900
C102			A	A	A	60	325	—	220	385	—	55	4	—	1.7	8 900
C108	Copper cadmium	High strength and conductivity with good ductility	A	A	A	60	460	—	280	700	—	45	4	—	2	8 900
CS101	Copper silicon	Moderate strength and ductility but with relatively low conductivity. Very good corrosion resistance, particularly in marine environments	A	A	A	90	—	390	340	—	460	40	—	32	24	8 550
CZ112	Naval brass	Good strength with moderate conductivity	A	A	A	—	—	250	—	—	430	—	—	30	6.5	8 400
PB102	Phosphor bronze	Good strength and corrosion resistance but relatively low conductivity	A	A	A	120	420	—	340	540	—	55	20	—	11	8 850
316S12	Austenitic stainless steel	Low conductivity. Excellent ductility. High strength. Excellent corrosion resistance	A	A	f	190	—	—	490	—	—	40	—	—	73	7 905

^a For appropriate British Standards, see Table 2.

^b Letters in the corrosion resistance columns indicate the following.

A: that normal conditions of exposure cause only a slight weathering of the surface with time;

B: that if the material is used unprotected there may be some loss in mechanical properties but this will be very slight and would normally be adequately covered by the conventional factors of safety applied in design;

C: that advice should be sought before using this material without protection.

^c Letters at the head of the typical mechanical and electrical properties columns indicate the following:

a is annealed;

h is hard;

m is as manufactured.

^d The material is a fully heat treated aluminium alloy.

^e In this case 0.2 % proof stress.

^f Not suitable for continuous immersion in salt water.

8 Dimensions

The component parts of lightning protection systems should have dimensions not less than those given in Tables 4 and 5, except in the special case considered in 27.4.

In situations where inspection or repair is likely to be unusually difficult, consideration should be given to the use of a size greater than the minimum given in Table 4.

The nearest standard size should be used, provided that the dimension is not smaller than that stated.

Table 4 — Minimum dimensions of component parts

Component	Dimensions mm	Area mm ²
Air terminations:		
aluminium, copper and galvanized steel strip	20 × 2.5	50.0
aluminium, aluminium alloy, copper, phosphor bronze and galvanized steel rods	8.0 dia.	50.0
Suspended conductors:		
stranded aluminium	7/3.0	50.0
stranded copper	19/1.8	50.0
stranded aluminium (steel reinforced)	7/3.0	50.0
stranded galvanized steel	7/3.0	50.0
Down conductors:		
aluminium, copper and galvanized steel strip	20 × 2.5	50.0
aluminium, aluminium alloy, copper and galvanized steel rods	8.0 dia.	50.0
Earth terminations:		
austenitic iron	14.0 dia.	153.0
copper and galvanized steel strip	20 × 2.5	50.0
copper and galvanized steel rods	8.0 dia.	50.0
hard drawn copper rods for direct driving into soft ground	8.0 dia.	50.0
hard drawn or annealed copper rods or solid wires for indirect driving or laying in ground	8.0 dia.	50.0
rods for hard ground	12.0 dia.	113.0
copper-clad or galvanized steel rods for harder ground	14.0 dia.	153.0
Fixed connections (bonds) in aluminium, aluminium alloy, copper and galvanized steel:		
external strip	20 × 2.5	50.0
external rods	8.0 dia.	50.0
internal strip	20 × 1.5	30.0
internal rods	6.5 dia.	33.0
Flexible or laminated connections (bonds):		
external, aluminium	20 × 2.5	50.0
external, annealed copper	20 × 2.5	50.0
internal, aluminium	20 × 1.5	30.0
internal, annealed copper	20 × 1.5	30.0
NOTE 1 For copper-clad steel rods, the core should be of low carbon steel with a tensile strength of approximately 600 N/mm ² . The cladding should be of 99.9 % pure electrolytic copper molecularly bonded to the steel core. The radial thickness of the copper should be not less than 0.25 mm.		
NOTE 2 Couplings for copper-clad steel rods should be made from copper-silicon alloy or aluminium-bronze alloy with a minimum copper content of 75 %.		
NOTE 3 The use of internal phosphor bronze dowels may give a lower resistance than the external couplings of diameter greater than the rod.		
NOTE 4 For galvanized steel rods, steel specified in BS 5970-1 should be used, the threads being cut before hot-dip galvanizing to BS 729.		
NOTE 5 Stranded conductors are not normally used for down conductors or earths.		
NOTE 6 Greater dimensions are required for the following:		
a) structures exceeding 20 m in height;		
b) special classes of structure;		
c) mechanical or corrosive reasons.		

Table 5 — Minimum thicknesses of sheet metal used for roofing and forming part of the air termination network

Material	Minimum thickness mm
Galvanized steel	0.5
Stainless steel	0.4
Copper	0.3
Aluminium and zinc	0.7
Lead	2.0
NOTE The figures in this table are based on contemporary building practice and will be satisfactory where the roof forms part of the lightning protection system. However, damage by way of puncturing may occur with a direct arc-connected strike (see also A.2.4)	

9 Basic considerations

Before proceeding with the detailed design of a lightning protection system, the following essential steps should be taken.

- a) It should be decided whether or not the structure needs protection and, if it does, what special considerations, if any, should be taken into account (see clauses 10 and 11).
- b) A close liaison should be ensured between the architect, the builder, the lightning protection system engineer and the appropriate authorities throughout the design stages.
- c) The procedures for testing, commissioning and future maintenance should be agreed.

10 Need for protection

10.1 General

Structures with inherent explosive risks, e.g. explosives factories, stores and dumps and fuel tanks, usually need the highest possible class of lightning protection system and recommendations for protecting such structures are given in clause 22.

For all other structures, the standard of protection recommended in the remainder of this code of practice is applicable and the only question remaining is whether protection is necessary or not.

In many cases, the need for protection may be self-evident, for example:

- a) where large numbers of people congregate;
- b) where essential public services are concerned;
- c) where the area is one in which lightning is prevalent;
- d) where there are very tall or isolated structures;
- e) where there are structures of historic or cultural importance;
- f) where there are structures with explosive or flammable contents.

However, there are many cases for which it is not so easy to make a decision. In these cases, reference should be made to 10.2 to 10.8 where the various factors affecting the risk of being struck and the consequent effects of a strike are discussed.

However, some factors cannot be assessed and these may override all other considerations. For example, a desire that there should be no avoidable risk to life or that the occupants of a building should always feel safe may decide the question in favour of protection, even though it would normally be accepted that there was no need. No guidance can be given in such matters but an assessment can be made taking account of the exposure risk (that is the risk of the structure being struck) and the following factors:

- 1) the use to which the structure is put;
- 2) the nature of its construction;
- 3) the value of its contents or consequential effects;
- 4) the location of the structure;
- 5) the height of the structure (in the case of composite structures, the overall height).

10.2 Estimation of exposure risk

The probability of a structure or building being struck by lightning in any one year is the product of the "lightning flash density" and the "effective collection area" of the structure. The lightning flash density, N_g , is the number of flashes to ground per square kilometre per year. Values of N_g vary significantly; estimates of the average annual density calculated from observations over a period of many years are shown in Figure 1 and corresponding information for overseas countries can be obtained by reference to Figure 3 and Table 6.

The effective collection area of a structure is the area of the plan of the structure extended in all directions to take account of its height. The edge of the effective collection area is displaced from the edge of the structure by an amount equal to the height of the structure at that point. Hence, for a simple rectangular building of length L , width W and height H (all in metres), the collection area has length $(L + 2H)$ m and width $(W + 2H)$ m with four rounded corners formed by quarter circles of radius H (in metres). This gives a collection area, A_c (in square metres), of:

$$A_c = LW + 2LH + 2WH + \pi H^2 \quad (1)$$

This is shown in Figure 29.

The probable number of strikes to the structure per year, p , is as follows:

$$p = A_c \times N_g \times 10^{-6} \quad (2)$$

It should first be decided whether this risk p is acceptable or whether some measure of protection is thought necessary.

Table 6 — Relationship between thunderstorm days per year and lightning flashes per square kilometre per year

Thunderstorm days per year	Flashes per square kilometre per year	
	Mean	Limits
5	0.2	0.1 to 0.5
10	0.5	0.15 to 1
20	1.1	0.3 to 3
30	1.9	0.6 to 5
40	2.8	0.8 to 8
50	3.7	1.2 to 10
60	4.7	1.8 to 12
80	6.9	3 to 17
100	9.2	4 to 20

NOTE The data for this table has been extracted from information in Conference Internationale des Grands Réseaux Electriques (CIGRE), *Lightning Parameters for Engineering Application* [1].

10.3 Risks associated with everyday living

To help in viewing the risk from lightning in the context of the risks associated with everyday living, Table 7 gives some figures based on the UK Government Royal Commission on Environmental Pollution [2]. The risk of death or injury due to accidents is a condition of living and many human activities imply a judgement that the benefits outweigh the related risks. Table 7 allows an appreciation of the scale of risk associated with different activities. Generally, risks greater than 10^{-3} (1 in 1 000) per year are considered unacceptable. With risks of 10^{-4} (1 in 10 000) per year, it is normal for public money to be spent to try to eliminate the causes or mitigate the effects. Risks less than 10^{-5} (1 in 100 000) are generally considered acceptable, although public money may still be spent on educational campaigns designed to reduce those risks which are regarded as avoidable.

10.4 Suggested acceptable risk

On the basis of 10.3, the acceptable risk figure has been taken as 10^{-5} per year, i.e. 1 in 100 000 per year.

10.5 Overall assessment of risk

Having established the value of p , the probable number of strikes to the structure per year (see 10.2), the next step is to apply the “weighting factors”, as given in Tables 8 to 12.

This is done by multiplying p by the appropriate factors to determine whether the result, the overall risk factor, exceeds the acceptable risk of $p_0 = 10^{-5}$ per year.

10.6 Weighting factors

In Tables 8 to 12, the weighting factor values are given under the headings *A* to *E* and denote the relative degree of importance or risk in each case.

Table 10 gives the weighting factor for contents or consequential effects. The effect of the value of the contents of a structure is clear; the term “consequential effects” is intended to cover not only material risks to goods and property but also such aspects as the disruption of essential services of all kinds, particularly in hospitals.

The risk to life is generally very small but, if a building is struck, fire or panic can naturally result. All possible steps should therefore be taken to reduce these effects, especially among children, the old and the sick.

For multiple use buildings, the value of weighting factor *A* applicable to the most severe use should be used.

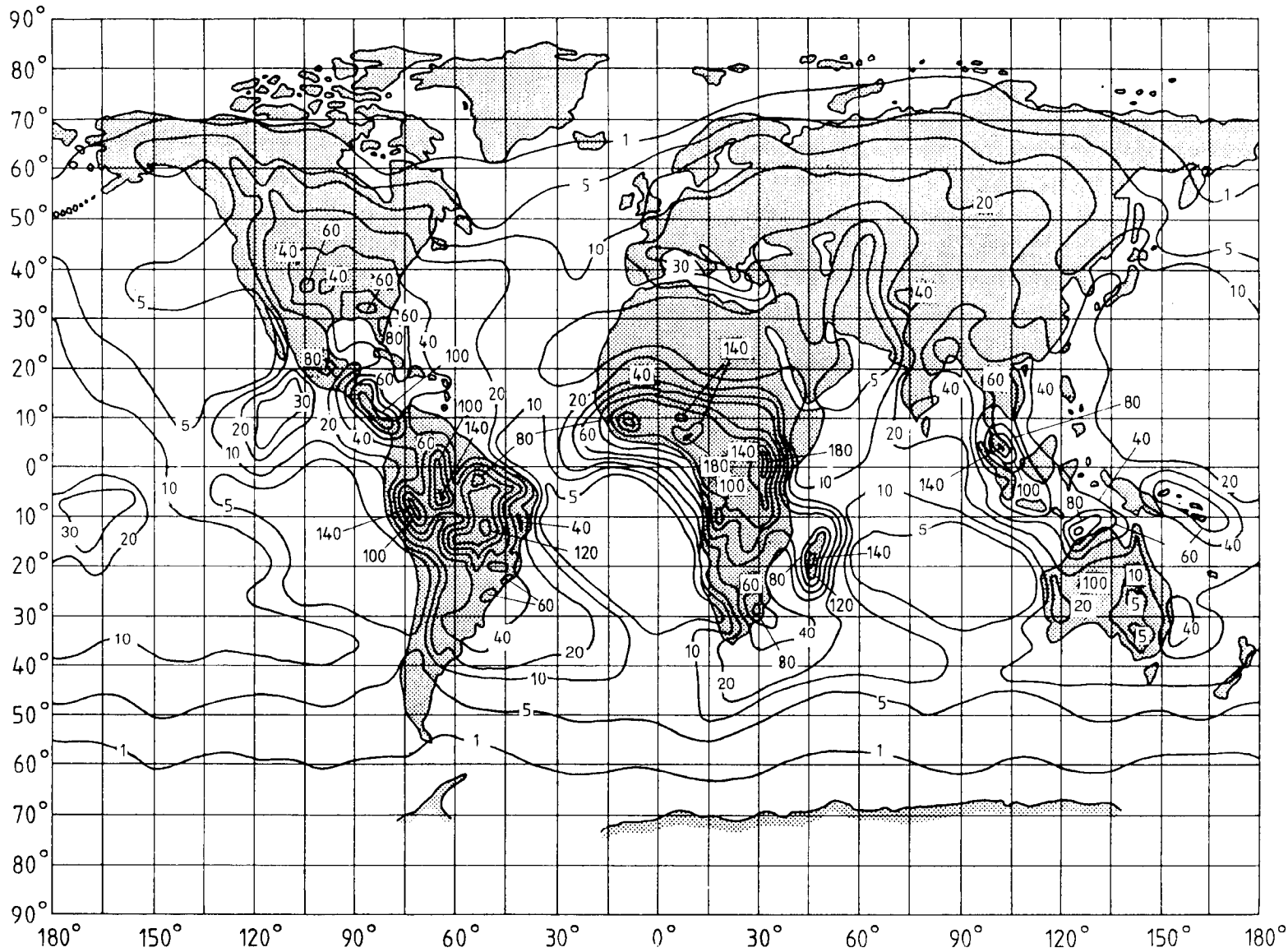

NOTE This map is based on information from the World Meteorological Organization records for 1955.

Figure 3 — Map showing thunderstorm days per year throughout the world

**Table 7 — Comparative probability of death for an individual per year of exposure
(order of magnitude only)**

Risk		Activity
1 in 400	(2.5×10^{-3})	Smoking (10 cigarettes per day)
1 in 2 000	(5×10^{-4})	All accidents
1 in 8 000	(1.3×10^{-4})	Traffic accidents
1 in 20 000	(5×10^{-5})	Leukaemia from natural causes
1 in 30 000	(3.3×10^{-5})	Work in industry, drowning
1 in 100 000	(1×10^{-5})	Poisoning
1 in 500 000	(2×10^{-6})	Natural disasters
1 in 1 000 000	(1×10^{-6})	Rock climbing for 90 s ^a Driving 50 miles by road ^a
1 in 2 000 000	(5×10^{-7})	Being struck by lightning ^a

NOTE The source of this table is Royal Commission on Environmental Pollution, Chairman Sir Brian Flowers, Sixth Report, *Nuclear Power and the Environment* (Cmd 6618) [2].

^a These risks are conventionally expressed in this form rather than in terms of exposure for a year.

**Table 8 — Weighting factor A
(use of structure)**

Use to which structure is put	Value of factor A
Houses and other buildings of comparable size	0.3
Houses and other buildings of comparable size with an outside aerial	0.7
Factories, workshops and laboratories	1.0
Office blocks, hotels, blocks of flats and other residential buildings other than those below	1.2
Places of assembly, e.g. churches, halls, theatres, museums, exhibitions, department stores, post offices, stations, airports, and stadium structures	1.3
Schools, hospitals, children's and other homes	1.7

**Table 9 — Weighting factor *B*
(type of construction)**

Type of construction	Value of factor <i>B</i>
Steel framed encased or reinforced concrete with metal roof	0.1
Steel framed encased with any roof other than metal ^a	0.2
Reinforced concrete with any roof other than metal	0.4
Brick, plain concrete or masonry with any roof other than metal or thatch	1.0
Timber framed or clad with any roof other than metal or thatch	1.4
Brick, plain concrete, masonry, timber framed but with metal roofing	1.7
Any building with a thatched roof	2.0

^a Structures of exposed metal which are continuous down to ground level are excluded from the table as lightning protection beyond adequate earthing is not needed.

**Table 10 — Weighting factor *C*
(contents or consequential effects)**

Contents or consequential effects	Value of factor <i>C</i>
Ordinary domestic or office buildings, factories and workshops not containing valuable or specially susceptible contents ^a	0.3
Industrial and agricultural buildings with specially susceptible contents ^a	0.8
Power stations, gas installations, telephone exchanges, radio stations	1.0
Key industrial plants, ancient monuments and historic buildings, museums, art galleries or other buildings with specially valuable contents	1.3
Schools, hospitals, children's and other homes, places of assembly	1.7

^a Specially valuable plant or materials vulnerable to fire or the results of fire.

**Table 11 — Weighting factor *D*
(degree of isolation)**

Degree of isolation	Value of factor <i>D</i>
Structure located in a large area of structures or trees of the same or greater height e.g. in a large town or forest	0.4
Structure located in an area with few other structures or trees of similar height	1.0
Structure completely isolated or exceeding at least twice the height of surrounding structures or trees	2.0

**Table 12 — Weighting factor *E*
(type of terrain)**

Type of country	Value of factor <i>E</i>
Flat country at any level	0.3
Hill country	1.0
Mountain country between 300 m and 900 m	1.3
Mountain country above 900 m	1.7

10.7 Interpretation of overall risk factor

The risk factor method given in this code of practice is intended to give guidance on what can, in some cases, be a difficult problem. If the result obtained is considerably less than 10^{-5} (1 in 100 000), in the absence of other overriding considerations, protection does not appear necessary; if the result is greater than 10^{-5} , for example 10^{-4} (1 in 10 000), sound reasons would be needed to support a decision not to provide protection.

When it is thought that the consequential effects will be small and that the effect of a lightning strike will most probably be merely slight damage to the fabric of the structure, it may be economic not to incur the cost of protection and to accept the risk. Even if this decision has been made, it is recommended that the calculation is still performed in order to give some idea of the magnitude of the risk being taken.

Structures are so varied that any method of assessment may lead to anomalies and those who have to decide on whether protection is necessary may have to exercise their judgement. For example, a steel framed building may be found to have a low risk factor but, as the addition of an air termination and earthing system will give greatly improved protection, the cost of providing this may be considered worthwhile.

A low risk factor may result for chimneys made of brick or concrete. However, where chimneys are free-standing or where they project for more than 4.5 m above the adjoining structure, protection is necessary regardless of the factor. Such chimneys are, therefore, not covered by the method of assessment. Similarly, structures containing explosives or flammable substances are subject to additional considerations (see clause 22 and 11.3).

Results of calculations for different structures are given in Table 13 and a specific case is worked through in 10.8.

NOTE Table 13 should be read in conjunction with Figure 4.

10.8 Sample calculation of overall risk factor

A hospital in the Thames Valley is 10 m high and covers an area of 70 m × 12 m. The hospital is located in flat country and isolated from other structures. The construction is of brick and concrete with a non-metallic roof.

To determine whether or not lightning protection is needed, the overall risk factor is calculated, as follows:

- a) *Number of flashes per square kilometre per year.* The map in Figure 1 gives a value for N_g of 0.6 flashes per square kilometre per year.
- b) *Collection area.* Using equation (1) in **10.2**, the collection area, A_c in square metres, is given by:

$$\begin{aligned} A_c &= LW + 2LH + 2WH + \pi H^2 \\ &= (70 \times 12) + 2(70 \times 10) + 2(12 \times 10) + (\pi \times 100) \\ &= 840 + 1\,400 + 240 + 314 \\ &= 2\,794 \text{ m}^2. \end{aligned}$$

- c) *Probability of being struck.* Using equation (2) in **10.2**, the probable number of strikes per year, p , is given by:

$$\begin{aligned} p &= A_c \times N_g \times 10^{-6} \\ &= 2\,794 \times 0.6 \times 10^{-6} \\ &= 1.7 \times 10^{-3} \text{ approximately.} \end{aligned}$$

- d) *Applying the weighting factors.* The following weighting factors apply:

- factor $A = 1.7$
 factor $B = 1.0$
 factor $C = 1.7$
 factor $D = 2.0$
 factor $E = 0.3$

The overall multiplying factor = $A \times B \times C \times D \times E$
 = 1.7

Therefore, the overall risk factor = $1.7 \times 1.7 \times 10^{-3}$
 = 2.9×10^{-3}

The conclusion is, therefore, that protection is necessary.

11 Zone of protection

11.1 General

In simple terms, the “zone of protection” is the volume within which a lightning conductor gives protection against a direct lightning strike by directing the strike to itself.

The size and shape of the zone varies according to the height of the building or vertical conductor. Generally, for structures not exceeding 20 m in height for a vertical conductor rising from ground level, the zone is defined as a cone with its apex at the tip of the conductor and its base on the ground; for a horizontal conductor, the zone is defined as the volume generated by a cone with its apex on the horizontal conductor moving from end-to-end. For structures exceeding 20 m in height, these zones are not necessarily applicable and it is recommended that additional lightning protection conductors be provided in the manner shown in Figure 5 (see also clause **20**) to protect against strikes on the side of the building.

11.2 Protective angle

For structures not exceeding 20 m in height, the angle between the side of the cone and the vertical at the apex of the cone is known as the protective angle, as shown in Figure 6. The magnitude of the protective angle cannot be precisely stated because it depends upon the severity of the stroke and the presence within the protective zone of conductive objects providing independent paths to earth. All that can be stated is that the protection afforded by a lightning conductor increases as the assumed protective angle decreases. For structures exceeding 20 m in height, the protective angle of any conductors up to the height of 20 m would be similar to that for lower structures. However, for structures above 20 m, where there is a possibility of such buildings being struck on the side, it is recommended that the protected volume is determined using the rolling sphere method (see **A.5**).

For the practical purpose of providing an acceptable degree of protection for an ordinary structure up to 20 m high and up to a height of 20 m for a higher structure, the protective angle of any single component part of an air termination network, namely either one vertical or one horizontal conductor, is considered to be 45° [see Figures 6a) and b)]. Between two or more vertical conductors, spaced at a distance not exceeding twice their height, the equivalent protective angle may, as an exception, be taken as 60° to the vertical; an example is shown in Figure 6c). For a flat roof, the area between parallel horizontal conductors is deemed to be effectively protected if the air termination network is arranged as recommended in **15.2** and **15.3**. For structures requiring a higher degree of protection, other protective angles are recommended (see clause **22**).

11.3 Structures of exceptional vulnerability

For structures of exceptional vulnerability, by reason of explosive or highly flammable contents, every possible protection may need to be provided, even against the rare occurrence of a lightning discharge striking within the protected zone defined in **11.1** and **11.2**. For this reason, a reduced zone of protection, and various other special measures should be taken as in clause **22**.

Table 13 — Examples of calculations for evaluating the need for protection

1	2	3	4	5	6	7	8	9	10	11	12	13
Reference in Figure 4	Description of structure	Risk of being struck, p			Weighting factors					Overall multiplying factor (product of columns 6 to 10)	Overall risk factor (product of columns 5 and 11)	Recommendations
		Collection area, A_c	Flash density, N_g	$p = A_c \times N_g \times 10^{-6}$	A Use of structure (Table 8)	B Type of construction (Table 9)	C Contents or consequential effects (Table 10)	D Degree of isolation (Table 11)	E Type of country (Table 12)			
a)	Maisonette, reinforced concrete and brick-built, non-metallic roof, Canterbury, Kent	3 327	0.7	2.3×10^{-3}	1.2	0.4	0.3	0.4	0.3	0.02	4.6×10^{-5}	Protection recommended
b)	Office building, reinforced concrete construction, non-metallic roof, West Bromwich	4 296	0.8	3.4×10^{-3}	1.2	0.4	0.3	0.4	0.3	0.02	6.8×10^{-5}	Protection recommended
c)	School, brick-built, in Kingston-on-Thames	1 456	0.6	8.7×10^{-4}	1.7	1.0	1.7	0.4	0.3	0.3	2.6×10^{-4}	Protection required
d)	Three bedroom detached dwelling house, brick-built, Bournemouth area	405	0.4	1.6×10^{-4}	0.3	1.0	0.3	0.4	0.3	0.01	1.6×10^{-6}	No protection required
e)	Village church in Lincolnshire	5 027	0.7	3.5×10^{-3}	1.3	1.0	1.7	2.0	0.3	1.3	4.6×10^{-3}	Protection required
f)	Theatre, reinforced concrete construction, metallic roof, Glasgow	4 090	0.1	4.1×10^{-4}	1.3	0.1	1.7	0.4	0.3	0.026	1.06×10^{-5}	Need for protection marginal, consider other factors, e.g. future life or operational importance of building

Table 13 — Examples of calculations for evaluating the need for protection (*continued*)

1 Reference in Figure 4	2 Description of structure	3 Risk of being struck, p			6 Weighting factors					11 Overall multiplying factor (product of columns 6 to 10)	12 Overall risk factor (product of columns 5 and 11)	13 Recommen- dations
		3 Collection area, A_c	4 Flash density, N_g	5 $p =$ $A_c \times N_g \times 10^{-6}$	6 A Use of structure (Table 8)	7 B Type of construction (Table 9)	8 C Contents or consequential effects (Table 10)	9 D Degree of isolation (Table 11)	10 E Type of country (Table 12)			
g)	Factory, steel framed encased, non-metallic roof, Aberystwyth	3 675	0.2	7.4×10^{-4}	1.2	0.2	0.3	0.4	0.3	0.01	7.4×10^{-6}	No protection required
h)	Shop, brick-built, tiled roof, Carlisle	1 070	0.2	2.1×10^{-4}	0.3	1.0	0.6	0.4	0.3	0.02	4.2×10^{-6}	No protection required

NOTE The risk of being struck p (column 5) is multiplied by the product of the weighting factors (columns 6 to 10) to yield an overall risk factor (column 12). This should be compared with the acceptable risk (10^{-5}) for guidance on whether or not to protect. Risks less than 10^{-5} do not generally require protection; risks greater than 10^{-4} require protection; for risks between 10^{-5} and 10^{-4} protection is recommended (see 10.3 to 10.8).

Reference	General arrangement	Collection area and method of calculation
(a)		$A_c = 14 \times 50 + 2(15 \times 50) + 2(15 \times 14) + \pi \times 15^2$ $A_c = 3\,327 \text{ m}^2$
(b)		$A_c = 15 \times 40 + 2(21 \times 40) + 2(21 \times 15) + \pi \times 21^2$ $A_c = 4\,296 \text{ m}^2$
(c)		$A_c = \pi \times 14^2 + 2(14 \times 30)$ $A_c = 1\,456 \text{ m}^2$
(d)		$A_c = 7 \times 8 + 2(6 \times 7) + \pi \times 9^2 + 10 \text{ (approx.) for areas in black}$ $A_c = 405 \text{ m}^2$
(e)		$A_c = \pi \times 40^2$ $A_c = 5\,027 \text{ m}^2$
(f)		$A_c = 12 \times 55 + 2(18 \times 55) + 2(18 \times 12) + \pi \times 18^2$ $A_c = 4\,090 \text{ m}^2$
(g)		$A_c = 25 \times 60 + 25 \times 30 + 6 \times 60 + 6 \times 50 + 6 \times 25 + 6 \times 25 + 6 \times 30 + 6 \times 24 + \frac{5}{4} \times \pi \times 6^2$ $A_c = 3\,675 \text{ m}^2$
(h)		$A_c = 20 \times 30 + 2(4 \times 30) + 2(4 \times 20) + \pi \times 4^2 + 20 \text{ (approx.) for area in black}$ $A_c = 1\,070 \text{ m}^2$

All dimensions are in metres

NOTE This figure should be used in conjunction with Table 13.

Figure 4 — Details of structures and collection areas

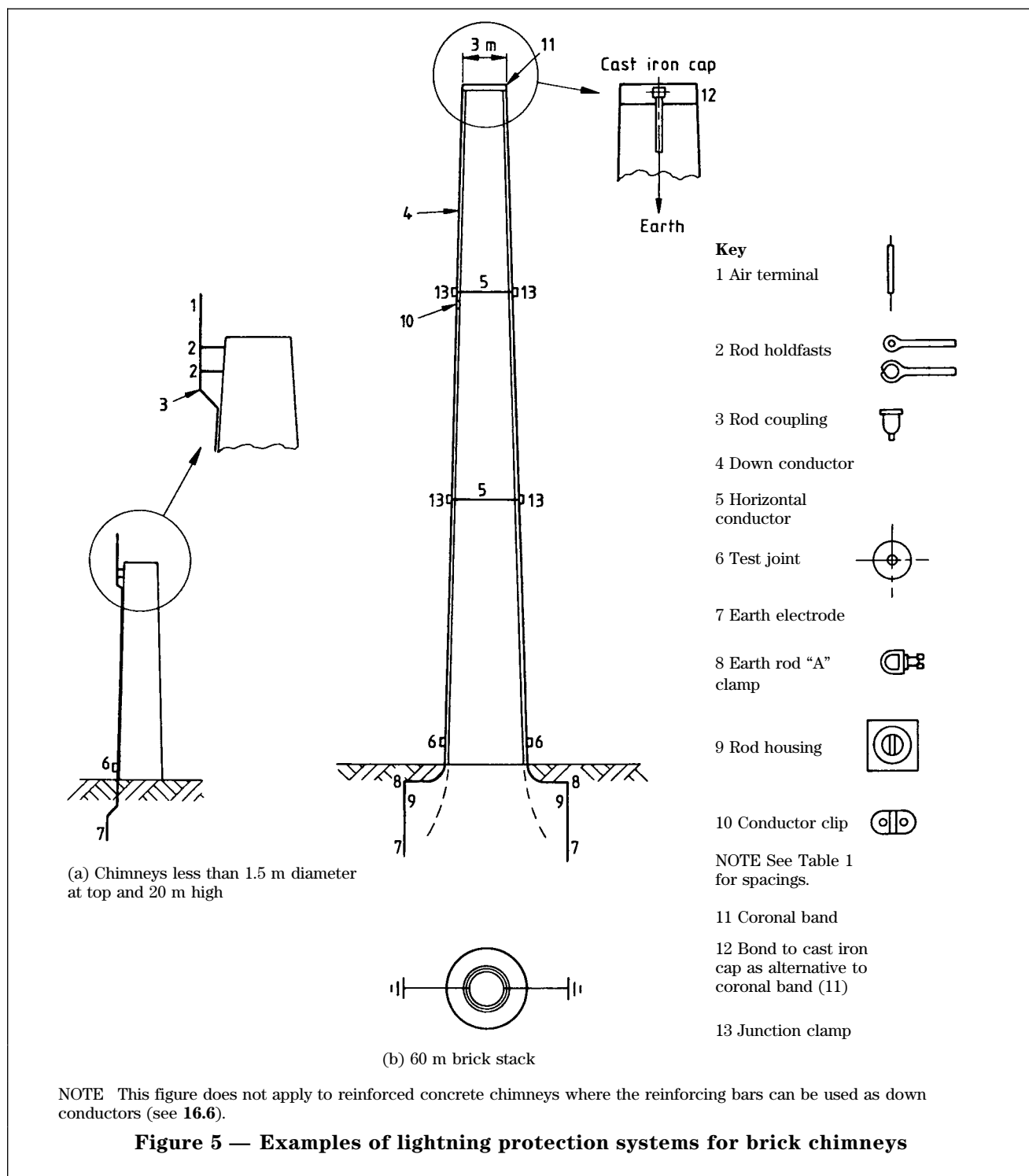

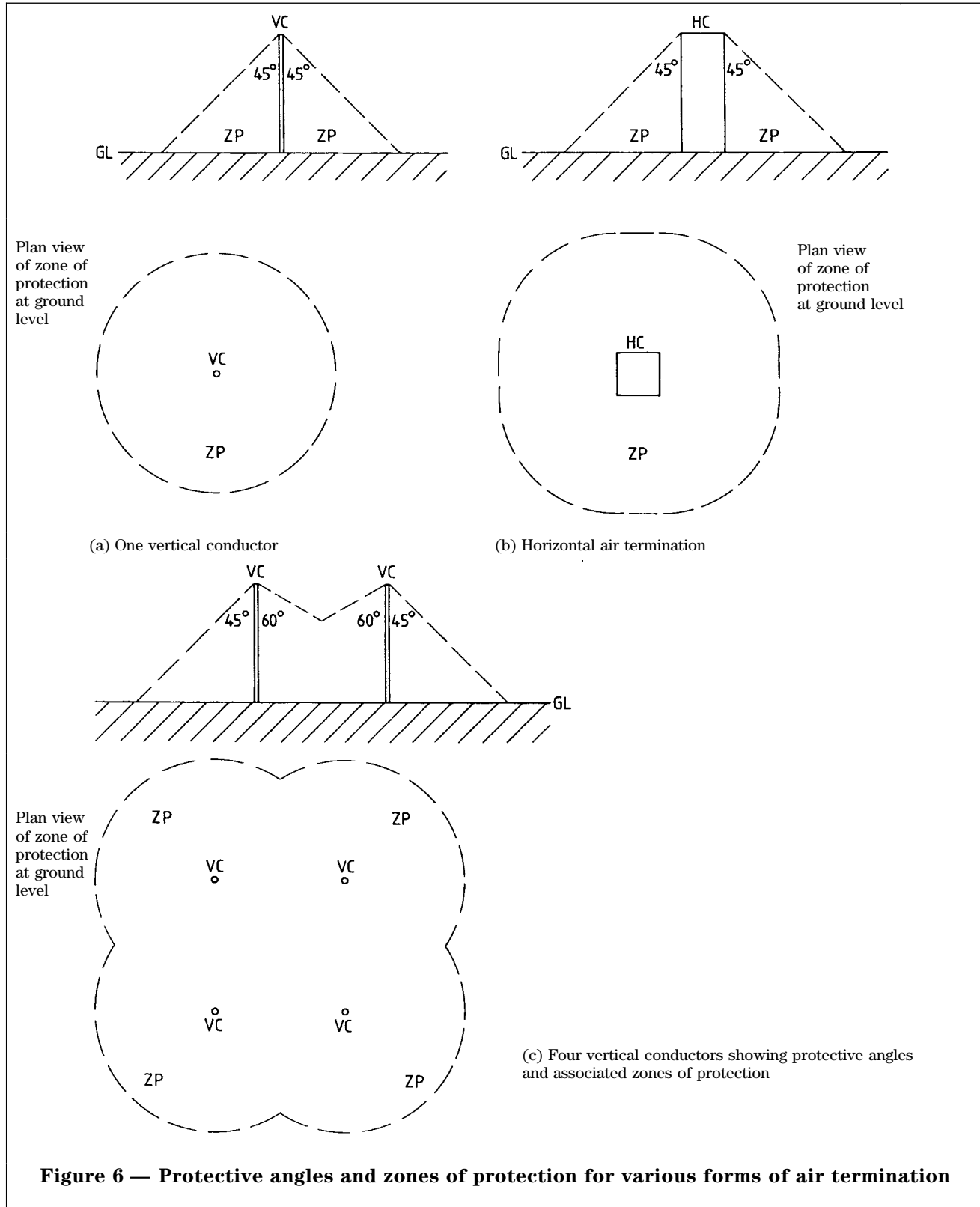

Figure 6 — Protective angles and zones of protection for various forms of air termination

12 General considerations for system design

The structure or, if it has not been built, the drawings and specifications should be examined, taking into account the recommendations of this code of practice.

In the case of structures having no suitable metallic members, it is important to consider the positioning of all the component parts of the lightning protection system so that they perform their function without detracting from the appearance of the structure.

Modern buildings use metal extensively in their structure and there is considerable benefit in utilizing such metal parts to maximize the number of parallel conducting paths; often the lightning protection is improved, worthwhile cost savings may result and the aesthetic appearance of the structure preserved. However, it should be borne in mind that a lightning strike to such a metal part, especially if it is beneath the surface, may damage the covering and cause masonry to fall. This risk can be reduced, but not eliminated, by use of a surface-mounted lightning protection system.

Examples of metal parts which should be incorporated into lightning protection systems are steel frames, concrete reinforcing bars, metal in or on a roof, window cleaning rails and handrails. Some metal within a structure may be used as a component of the lightning protection system; for example, sheet piling, being in contact with the general mass of earth, may be used as an earth electrode and is unlikely to be improved upon by the addition of rods or tapes.

The whole structure should be provided with a fully interconnected lightning protection system, i.e. no part of the structure should be protected in isolation.

13 Consultation

13.1 General

Consultation should take place between the designer of the lightning protection system and the interested parties indicated in **13.2** to **13.6** before and during all stages of design.

13.2 Architect

As far as practicable, the following should be determined:

- a) the routing of all conductors;
- b) the general areas available for earth termination networks and reference earth electrodes;
- c) the material(s) for conductors;
- d) the extent of the work and the division of responsibility for primary fixings to the structure, especially those affecting the watertightness of the fabric, chiefly roofing;
- e) the material(s) to be used in the structure, especially for any continuous metal, e.g. stanchions or reinforcing;
- f) the use to which the structure is to be put;
- g) the details of all metallic service pipes, rainwater systems, rails and the like entering or leaving the structure or within the structure which may need to be bonded to the lightning protection system;
- h) the extent of any buried services which could affect the siting of the earth termination network(s);
- i) details of any equipment, apparatus, plant or the like to be installed within or near the building and which would need to be bonded to the lightning protection system.

13.3 Public utilities

Agreement should be reached on the bonding of services to the lightning protection system. Because of the introduction of new materials and practices, reliance should not be placed on agreements reached for other structures.

13.4 Fire and safety officers

Agreement should be reached on:

- a) the need for a lightning protection system on structures containing flammable or explosive materials;
- b) the routes and material(s) for construction of ducts and sealing at floors if internal conductors are being considered;
- c) the method of lightning protection to be adopted in the unlikely event of a structure having a flammable roof.

13.5 Television and radio installers

Agreement should be reached on the need to bond aerial supports and screens of cables to the lightning protection system (see clause **26** and also BS 6330).

13.6 Builder

Agreement should be reached on:

- a) the form, positions and numbers of primary fixings to be provided by the builder;
- b) any fixings provided by the lightning protection system contractor to be installed by the builder;
- c) the positions of conductors to be placed beneath the structure;
- d) whether any components of the lightning protection system are to be used during the construction phase, e.g. the permanent earth termination network could be used for earthing cranes, railway lines, scaffolding, hoists and the like during construction;
- e) for steel framed structures, the numbers and positions of stanchions and the form of fixing to be made for the connection of earth terminations;
- f) whether metallic roof coverings, where used, are suitable as part of the lightning protection system and the method of attachment of conductors to earth;
- g) the nature and location of services entering the structure above and below ground including railway lines, crane rails, wire ropeways, conveyor systems, television and radio aerials and their metal supports, metal flues, flue-liners, window cleaning gear and dry risers;
- h) the position and number of flag-masts, roof level plant rooms (e.g. lift motor rooms, ventilating, heating and air-conditioning plant rooms), water tanks and other salient features;

- i) the construction to be employed for roofs and walls in order to determine appropriate methods of fixing conductors, specifically with a view to maintaining the weather-tightness of the structure;
- j) possible penetration of a waterproofing membrane where earth terminations have to be sited beneath the structure, especially in "urban" situations and in confined spaces on industrial sites;

NOTE The same general consideration applies to the reference earth electrode for use in initial and periodic testing.

- k) the provision of holes through the structure, parapets, cornices etc. to allow for the free passage of the down conductor;
- l) the provision of bonding connections to a steel frame, reinforcement bars and other metal;
- m) the most suitable choice of metal for the conductors taking account of corrosion, especially at bimetallic contacts;
- n) the accessibility of test joints, protection by non-metallic casings from mechanical damage or pilferage, lowering of flag-masts or other removable objects, facilities for periodic inspection, especially on chimneys;
- o) the preparation of a drawing incorporating the above details and showing the positions of all conductors and of the main components.

14 Component parts

The principal components of a lightning protection system are as follows:

- a) air terminations;
- b) down conductors;
- c) joints and bonds;
- d) test joints;
- e) earth terminations;
- f) earth electrodes.

These are dealt with in detail in clauses **15** to **18** and typical designs of various fixings are shown in Figure 2, Figure 8 and Figure 9.

15 Air terminations

15.1 General

Basic guidelines on the design of air terminations are given in **15.2** and explanatory notes on the various forms that are commonly used follow in **15.3**.

15.2 Basic rules

Air termination networks may consist of vertical or horizontal conductors or combinations of both (see, for example, Figures 10 to 15).

No part of the roof should be more than 5 m from the nearest horizontal conductor (but see notes 1 and 2 on Figure 11). For large flat roofs, this is achieved typically by use of an air termination network mesh of approximately 10 m × 20 m. On multiple ridge roofs, additional conductors are necessary if the separation, S (in metres), of the ridges is greater than $10 + 2H$, where H is the height of the ridge (in metres). See Figure 12.

On a reinforced concrete structure, the air termination should be connected to the reinforcing bars in the number of positions needed for down conductors.

All metallic projections on or above the main surface of the roof which are connected, intentionally or fortuitously, to the general mass of the earth should be bonded to, and form part of, the air termination network (see, for example, Figure 5 and Figure 7 and also refer to Figure 16).

Metallic coping, roof coverings, handrails (see clause **12**), window washing equipment and metallic screens around play areas should be considered for inclusion as part of the air termination network (see Figure 5, Figure 7 and Figure 17).

If portions of a structure vary considerably in height, any necessary air terminations or air termination networks for the lower portions should be joined to the down conductors of the taller portions in addition to being joined to their own down conductors.

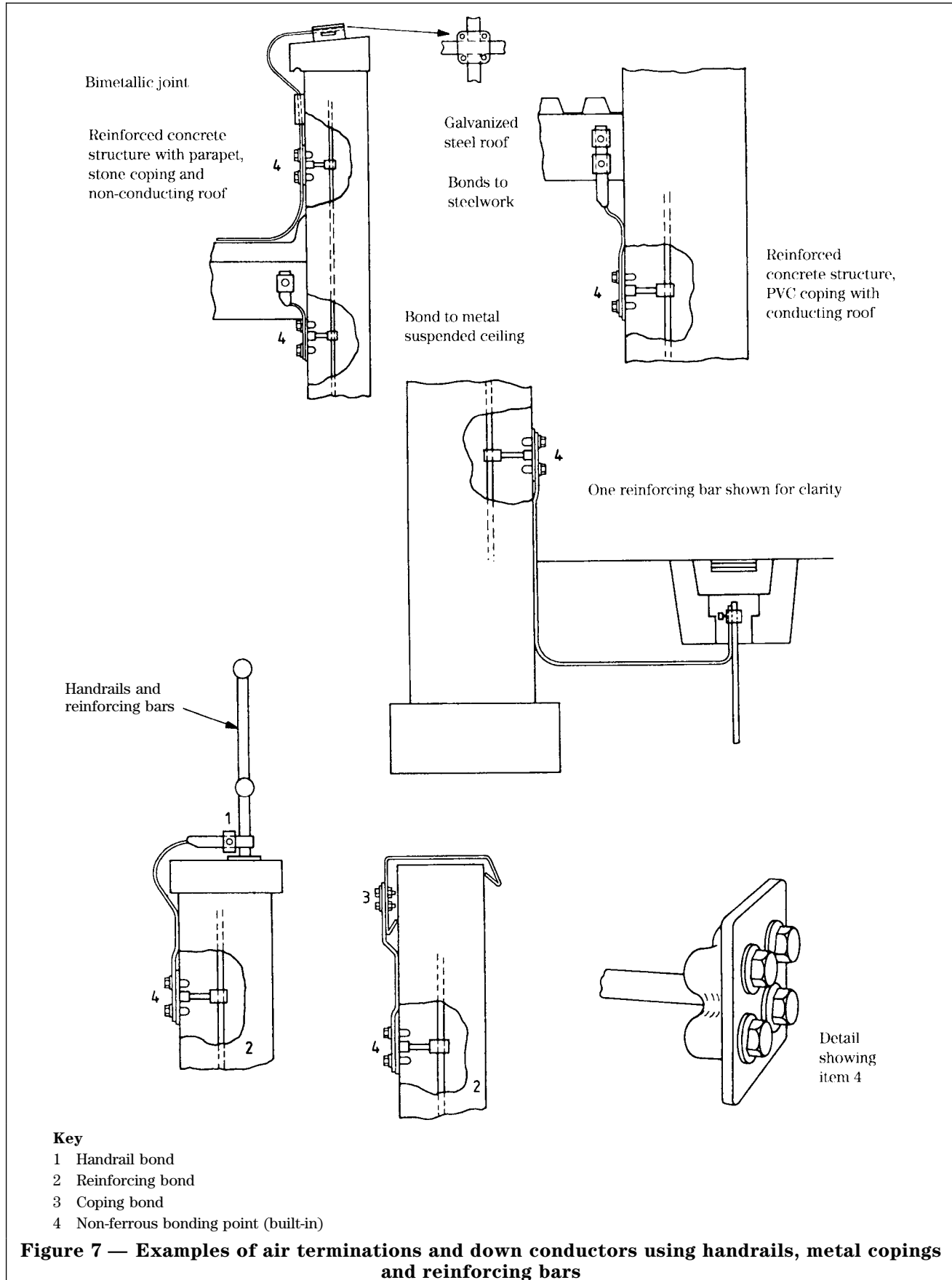

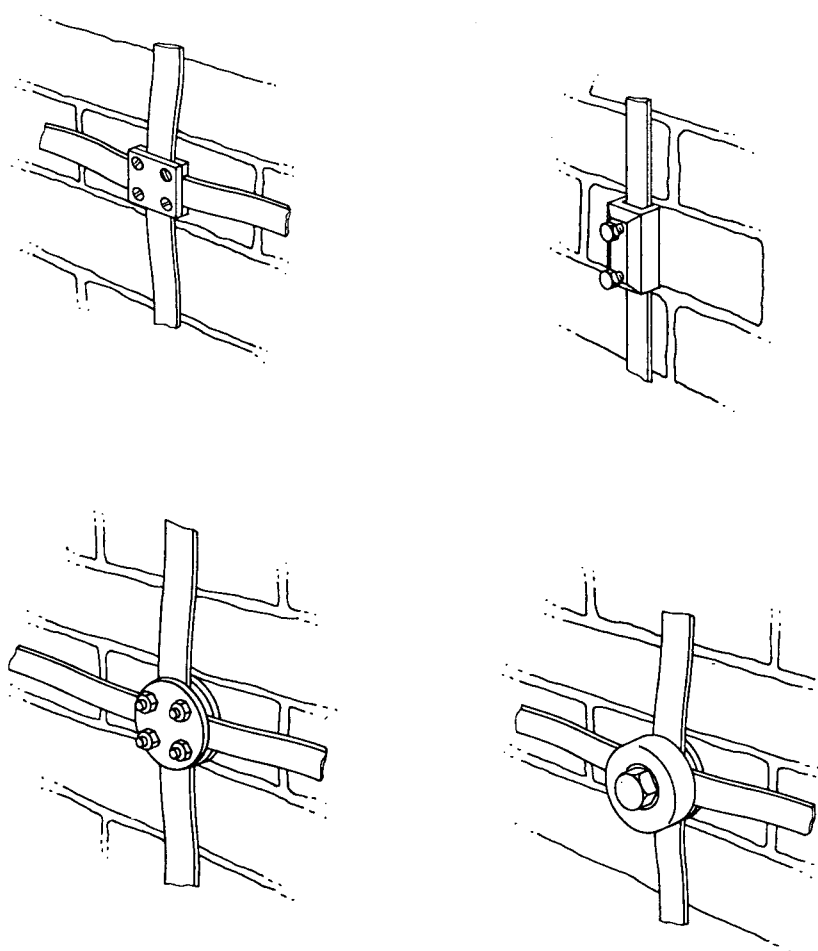

NOTE A corrosion inhibitor should be used on all joints and bonds.

Figure 8 — Test joints

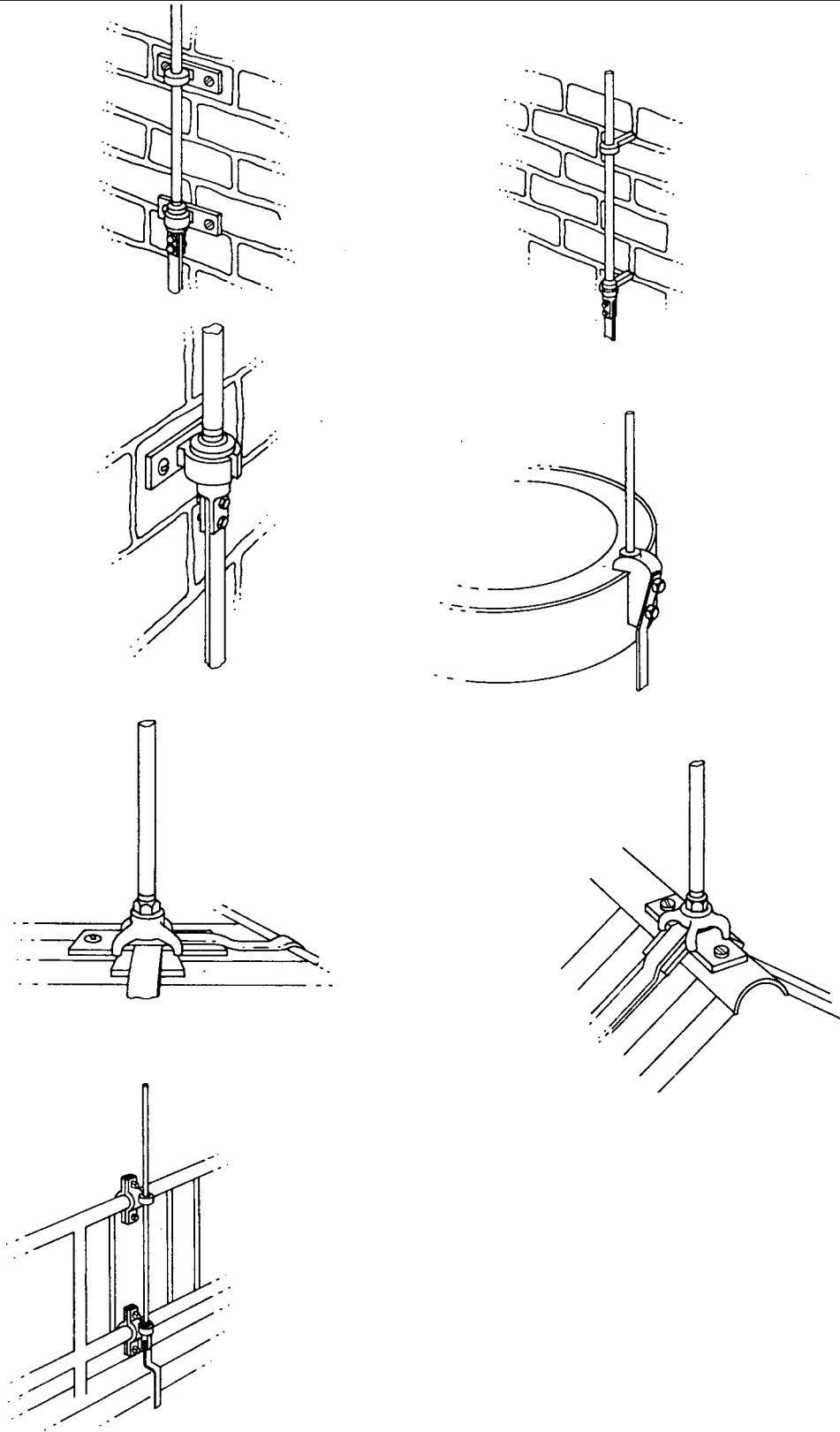

Figure 9 — Typical forms of vertical air terminations

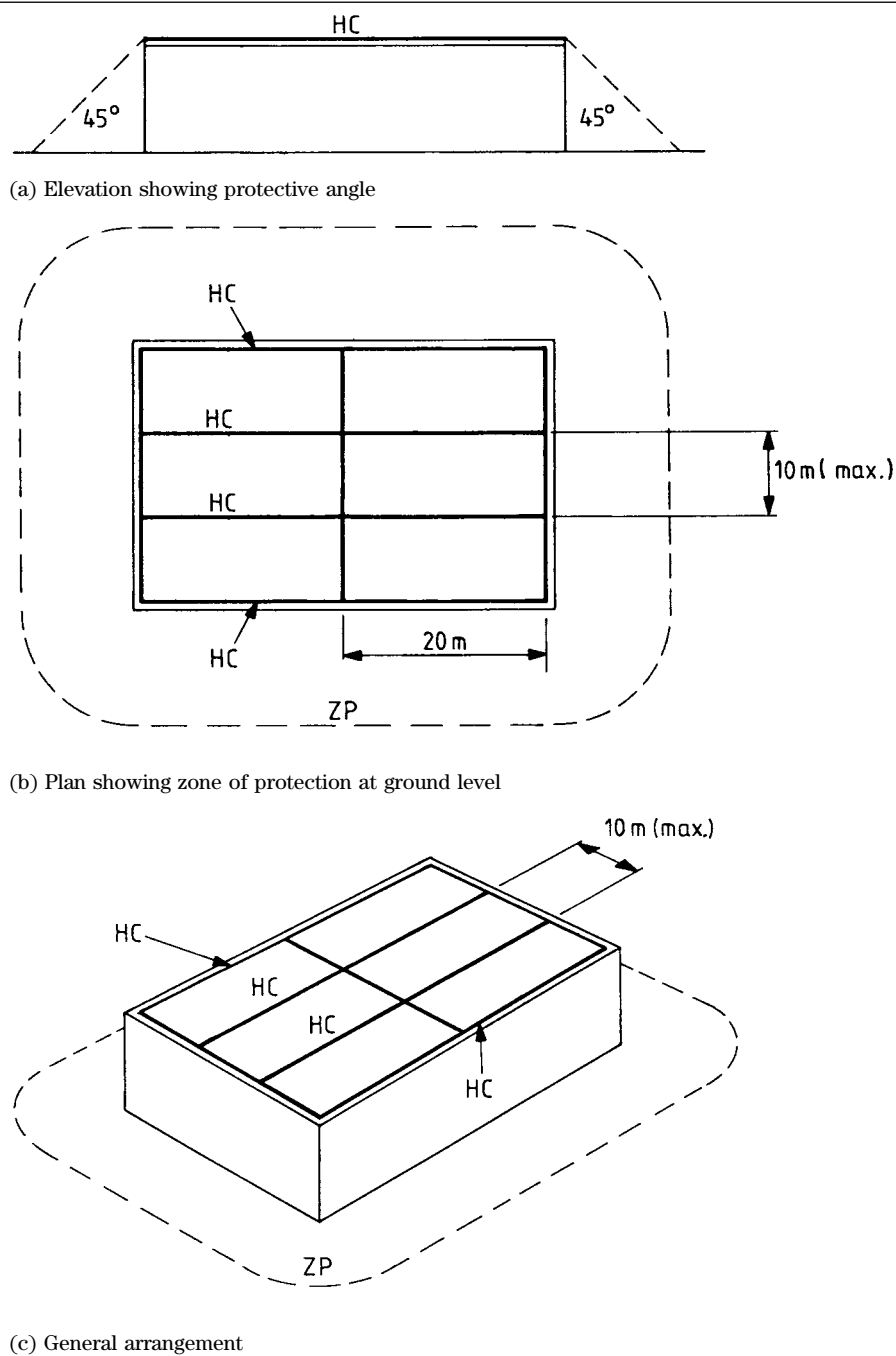
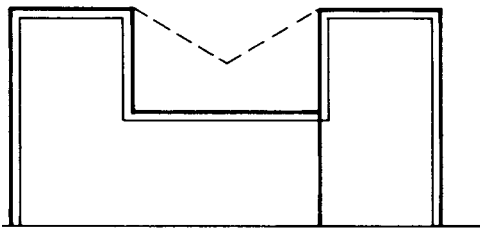
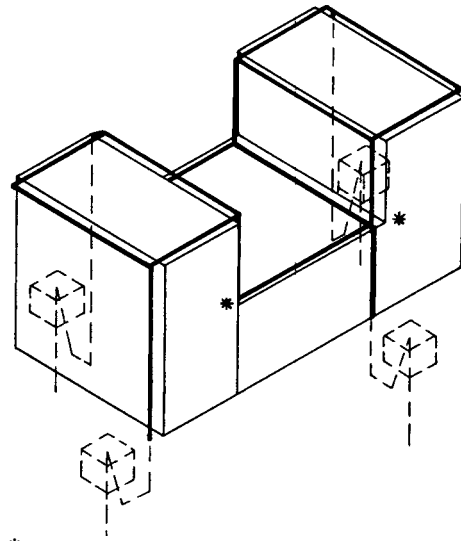

Figure 10 — Air terminations for a flat roof



View from B



* Join down conductors and horizontal conductors on lower parapet.

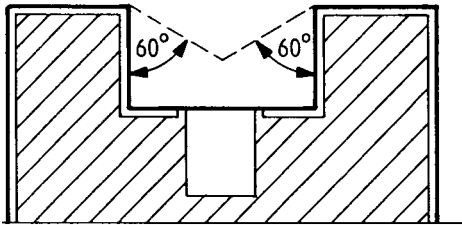

Section A-A

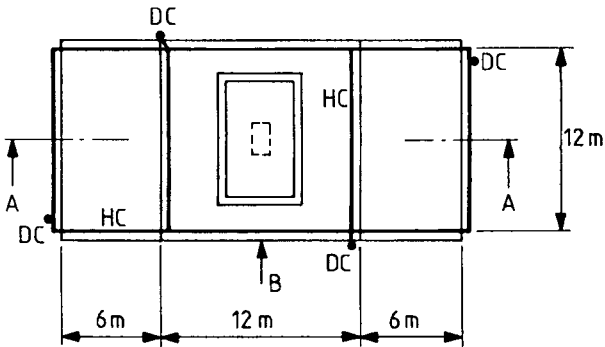

Perimeter = $24 + 24 + 12 + 12 = 72$ m
 Number of down conductors required (see 16.3) = $72/20 = 4$.

NOTE 1 An air termination along the outer perimeter of the roof is required and no part should be more than 5 m from the nearest horizontal conductor, except that an additional 1 m may be allowed for each metre by which the part to be protected is below the nearest conductor.

NOTE 2 Horizontal conductors are not necessary on the parapets of the light well; a zone of protection of 60° is provided by the two adjacent horizontal conductors for structures less than 20 m high. This principle does not apply to taller structures.

Figure 11 — Air terminations for flat roofs at different levels

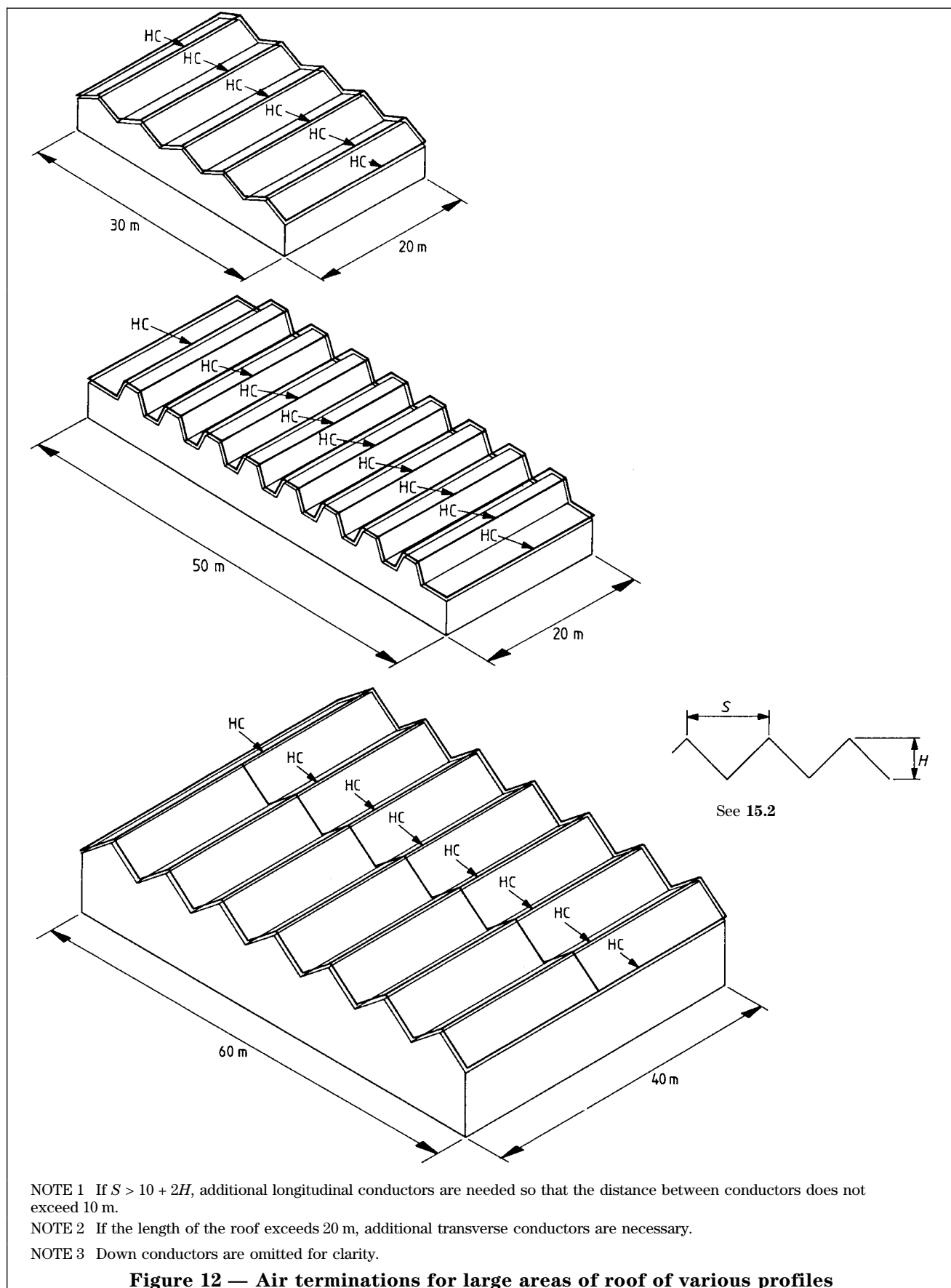

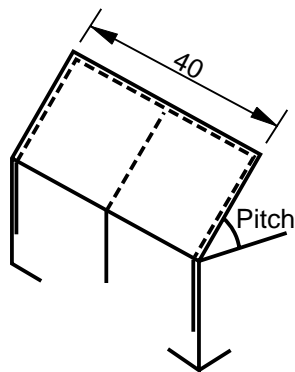

1) For roofs of pitch 45° and above, only a ridge conductor is required

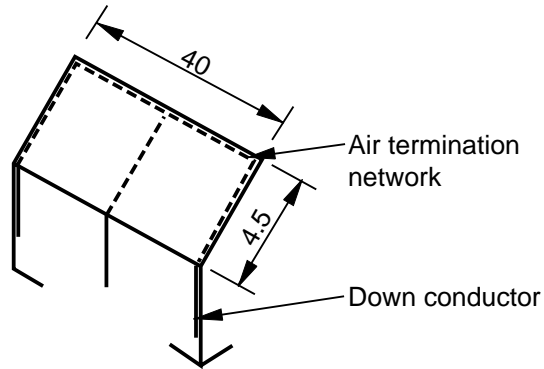

2) For roofs where the eaves are within 5 m of the ridge, only a ridge conductor is required

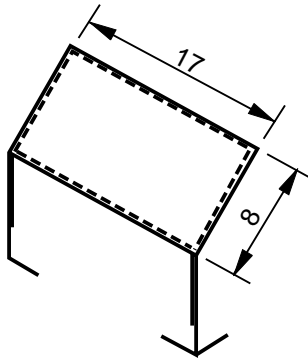

3)

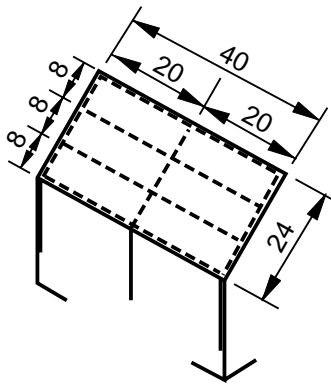

4)

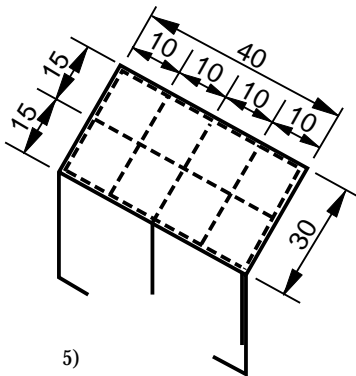

5)

Dimensions are in metres

For pitched roofs where cases 1) and 2) do not apply, ridge and eaves conductors are to be installed, with any intermediate transverse and longitudinal conductors being added to form a maximum $20\text{ m} \times 10\text{ m}$ mesh (see 15.2) as detailed in 3), 4) and 5).

NOTE 1 If there are items of metalwork which are electrically continuous and are in accordance with Table 5, they may be utilized as part of the air termination network (e.g. metal guttering in place of the eaves conductor).

NOTE 2 These are examples of air terminations for various sizes of roof, but the criteria to be met when designing the roof network are:

- no part of the roof should be greater than 5 m from the nearest conductor;
- a $20\text{ m} \times 10\text{ m}$ mesh should be maintained.

a) Air terminations and down conductors

Figure 13 — Air terminations and concealed conductors for buildings less than 20 m high with sloping roofs

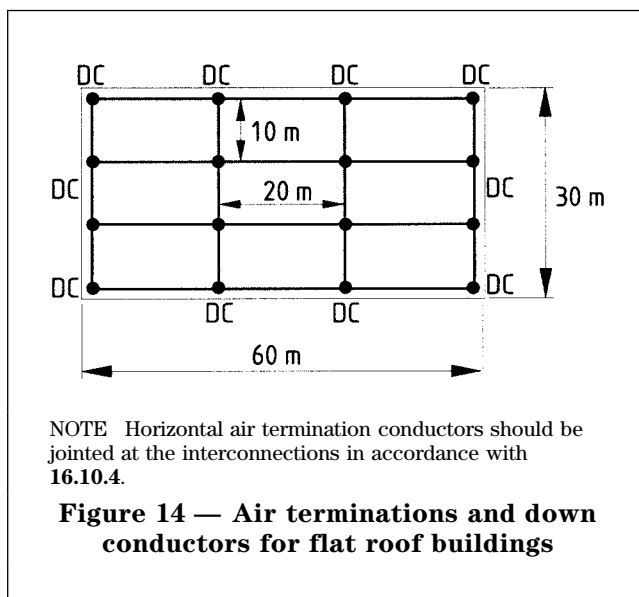
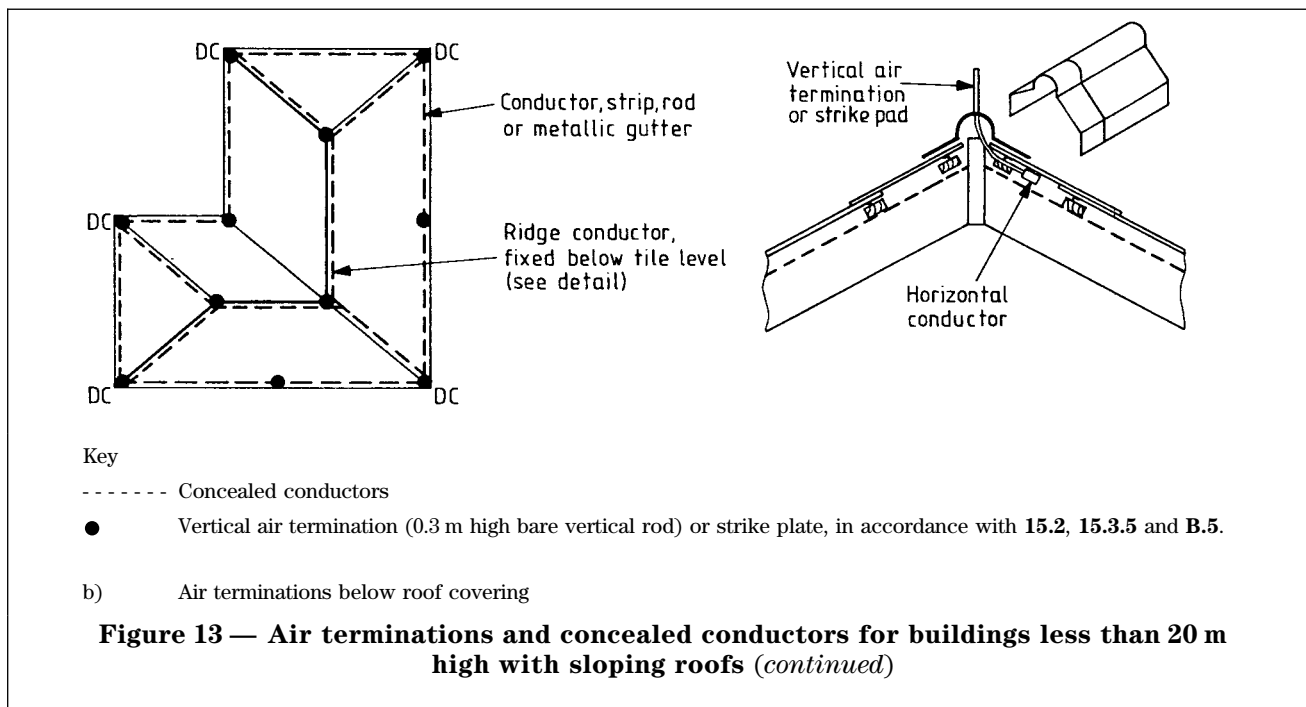

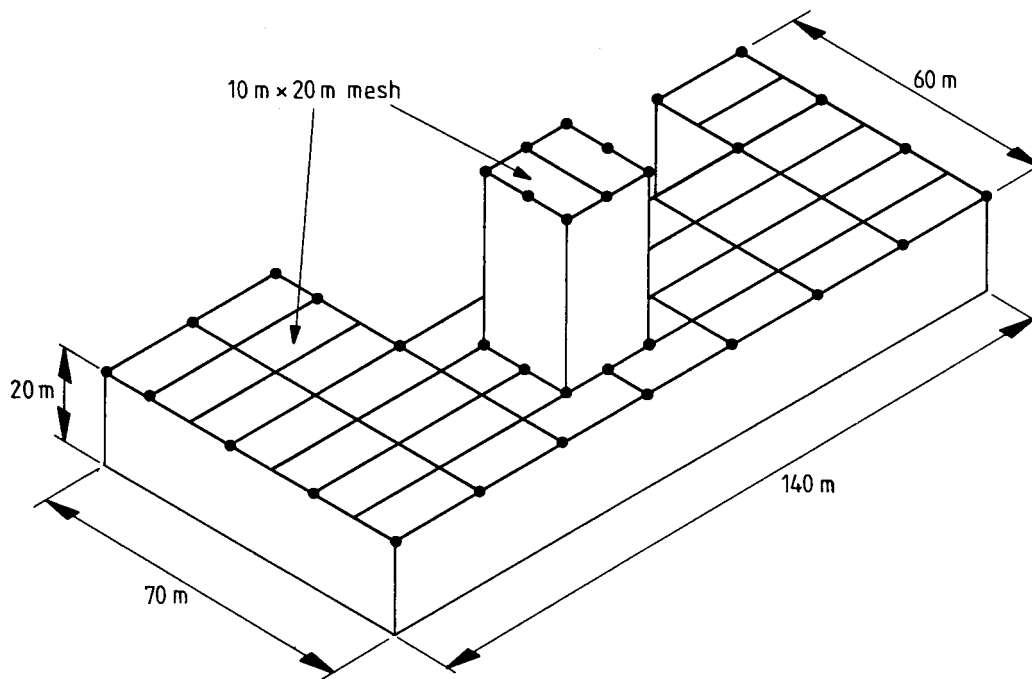

NOTE The air termination network for a tall reinforced concrete or steel structure should be as follows:

- a) horizontal conductors on roofs from a $10\text{ m} \times 20\text{ m}$ network;
- b) bonds to steelwork at corners, at 20 m intervals around the periphery and on the tower 0.5 m above the lower roof level;
- c) key bonding to the building steelwork ●.

Figure 15 — Air terminations for tall conducting structures

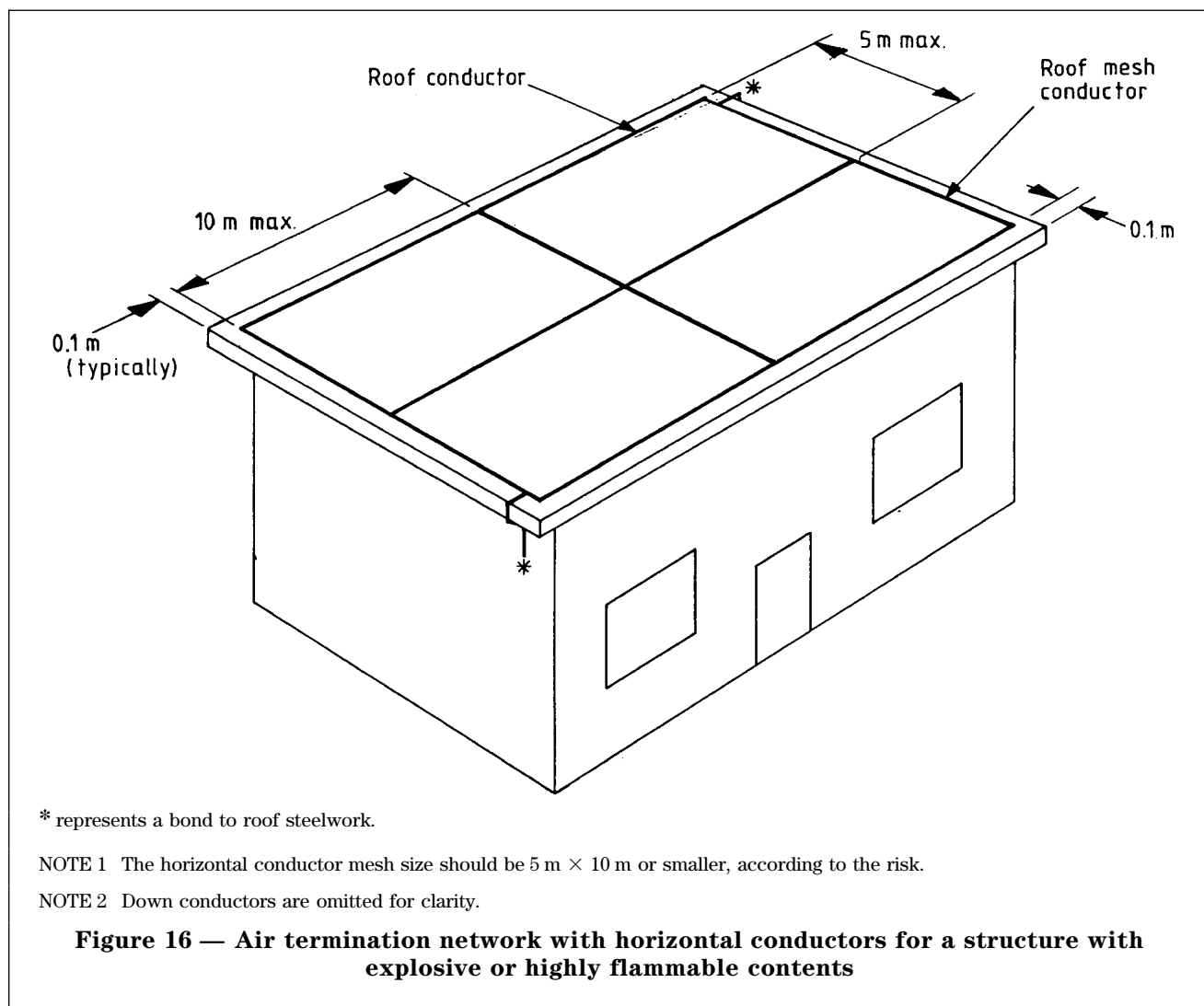

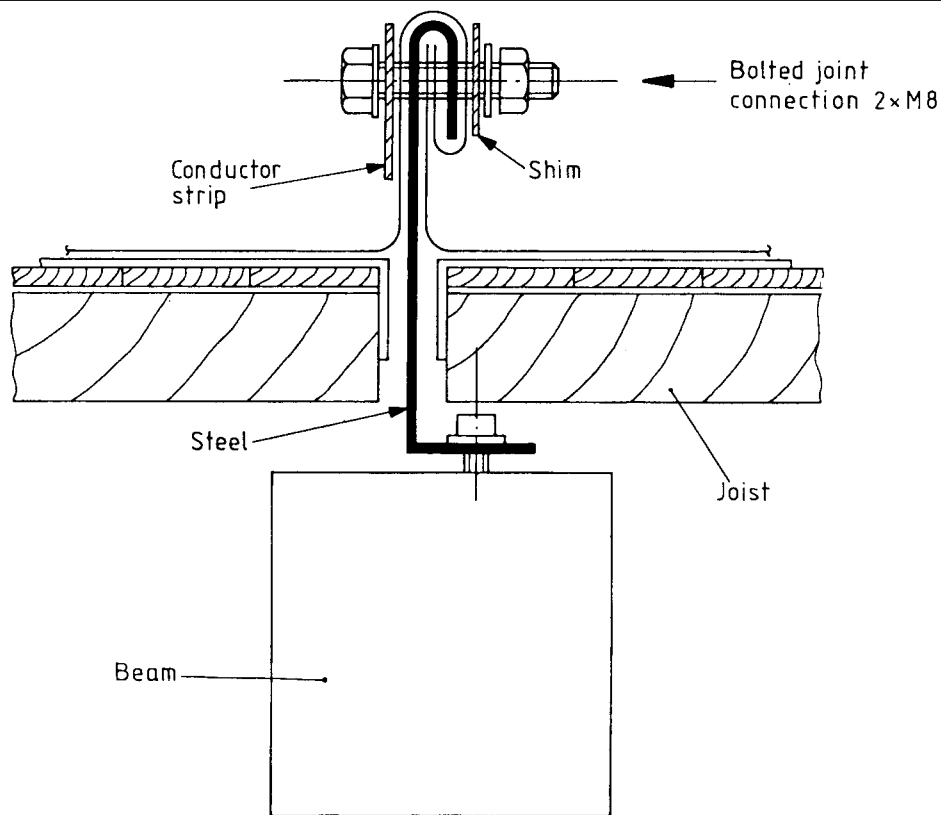

NOTE Minimum dimensions when a metallic roof covering is used as part of the air termination network are as follows:

— galvanized steel	0.5 mm;
— copper	0.3 mm;
— aluminium	0.7 mm;
— zinc	0.7 mm;
— lead	2.0 mm.

Figure 17 — Air termination for a flat roof showing connection to a standing seam joint when a metallic roof is used as part of the air termination network

15.3 Forms of air termination

15.3.1 General

In practice, very few of the many forms of structure can be protected by any reasonable arrangement of single conductors. Recommendations for various forms of air termination are given in Figures 10 to 15. Guidance on their application is given in 15.3.2 to 15.3.6. Although, for the sake of clarity, down conductors and earth terminations have been omitted from the figures, these should be provided as recommended elsewhere in this code of practice, taking account as necessary of the architectural and structural features of the structure and of the site conditions.

15.3.2 Simple vertical conductor(s)

Figure 6a) shows a simple vertical conductor and the zone of protection in plan and elevation.

Figure 6c) shows four vertical conductors with the increased angle of protection available between them. The zones of protection for this arrangement are shown in the plan view. However, although in suitable cases advantage may be taken of the increased protection zone, there can be no certainty about the precise shape of the envelope since this is only a statistical concept.

15.3.3 Horizontal conductor(s) for flat roofs

Figure 6b) shows a simple horizontal air termination consisting of a roof conductor around the periphery of a rectangular building. The resulting zone of protection is shown in plan and elevation.

Figure 10 shows a typical arrangement for a structure with a large area of flat roof where the use of a system of horizontal roof conductors is strongly recommended (see 15.2). The network of the air termination on a flat roof is recommended to be in the form of a grid to reduce the effect of flashover caused by large induction loops.

15.3.4 Large structures

For buildings formed by tall block(s) with abutting lower block(s), such as that shown in Figure 15, protection should comprise air terminations, down conductors and earth terminations. The protection for the lower block(s) should be designed as though the tall block(s) and its lightning protection does not exist. The earth termination network and the bonding should be common (see Figure 7, 16.9, 16.10, clause 17 and A.1, A.2 and A.5).

Figure 11 shows the type of building formed by a large rectangular block having a flat roof at different levels. The block is protected by a horizontal air termination consisting of roof conductors along the outer edges of the roof and also along the inner edges of any parts of the roof that are higher than adjacent parts, unless they fall in the zone of protection of a higher conductor, e.g. the light well. Additional roof conductors may be necessary for large roof areas (see note 1 to Figure 11). All elements of the lightning protection system should be joined together as recommended in clause 12 (see Figure 15 and Figure 31).

NOTE In Figure 15, the horizontal conductors at the base of the tower are used to connect the roof mesh to the down conductors present in the steelwork of the tower. They are within the zone of protection; otherwise such conductors would not be necessary.

Figure 12 shows examples of common profiles for roofs covering large areas. Horizontal air terminations are shown which consist of ridge conductors bonded at both ends by conductors following the roof profiles. If the roof is longer than 20 m, additional transverse conductors are positioned every 20 m or part thereof.

For structures over 20 m high and of complex geometry, the rolling sphere method (see A.5 and Figure A.1) will determine the required locations for air terminations (unless they are inherently provided by structural steelwork or reinforcing).

15.3.5 Tiled roofs

On non-conducting roofs, the conductor may be placed either under or, preferably, over the tiles. Although mounting the conductor under the tiles has the advantages of simplicity and a reduced risk of corrosion, it is preferable, where adequate fixing methods are available, to install it along the top of the tiles (i.e. externally). This reduces the risk of damage to the tiles should the conductor receive a direct strike and also simplifies inspection.

Conductors placed below the tiles should preferably be provided with short vertical finials or strike plates which protrude above roof level and are spaced not more than 10 m apart. Churches and similar non-conducting structures should be treated as special cases; the presence of the tower or spire should be disregarded when designing the protection for the lower parts of the structure (see Figure 31).

15.3.6 Simple structures with explosive hazards

Figure 18 shows the type of installation primarily intended for simple structures with explosive hazards. It consists of two vertical conductors connected by a horizontal catenary wire. The zone of protection is shown in plan and elevation and reflects the effect of the sag in the catenary wire (see 22.2.1).

16 Down conductors

16.1 General

The function of a down conductor is to provide a low impedance path from the air termination to the earth electrode so that the lightning current can be safely conducted to earth.

This code of practice covers the use of down conductors of various types including the use of strip, rod, reinforcing bars and structural steel stanchions, etc. Any good conductor which forms part of the building structure can be included, appropriately jointed to the air and earth terminations. In general, the greater the number of down conductors used, the lower the risk of side-flashing and other undesirable phenomena. Likewise, large conductors reduce the risk of side-flashing, especially if insulated. However, the performance of the "shielded" coaxial down lead system is not significantly different in any respect from conductors of similar overall dimensions and insulation. Use of such shielded conductors does not allow a reduction in the number of down conductors recommended by this code of practice.

In practice, depending upon the form of the building, it is often necessary to have multiple down conductors in parallel, some or all of which may be part of the building structure itself. For example, a steel framed or reinforced concrete structure might need no added down conductors as the framework itself provides an efficient natural network of many paths to earth; conversely a structure made entirely from non-conducting materials would need down conductors deployed according to the size and form of the structure.

In brief, the down conductor system should, where practicable, be directly routed from the air termination to the earth termination network and be symmetrically placed around the outside walls of the structure starting from the corners. In all cases, consideration should be given to side-flashing. (See also 16.5.)

Design recommendations are given in 16.2 to 16.11.

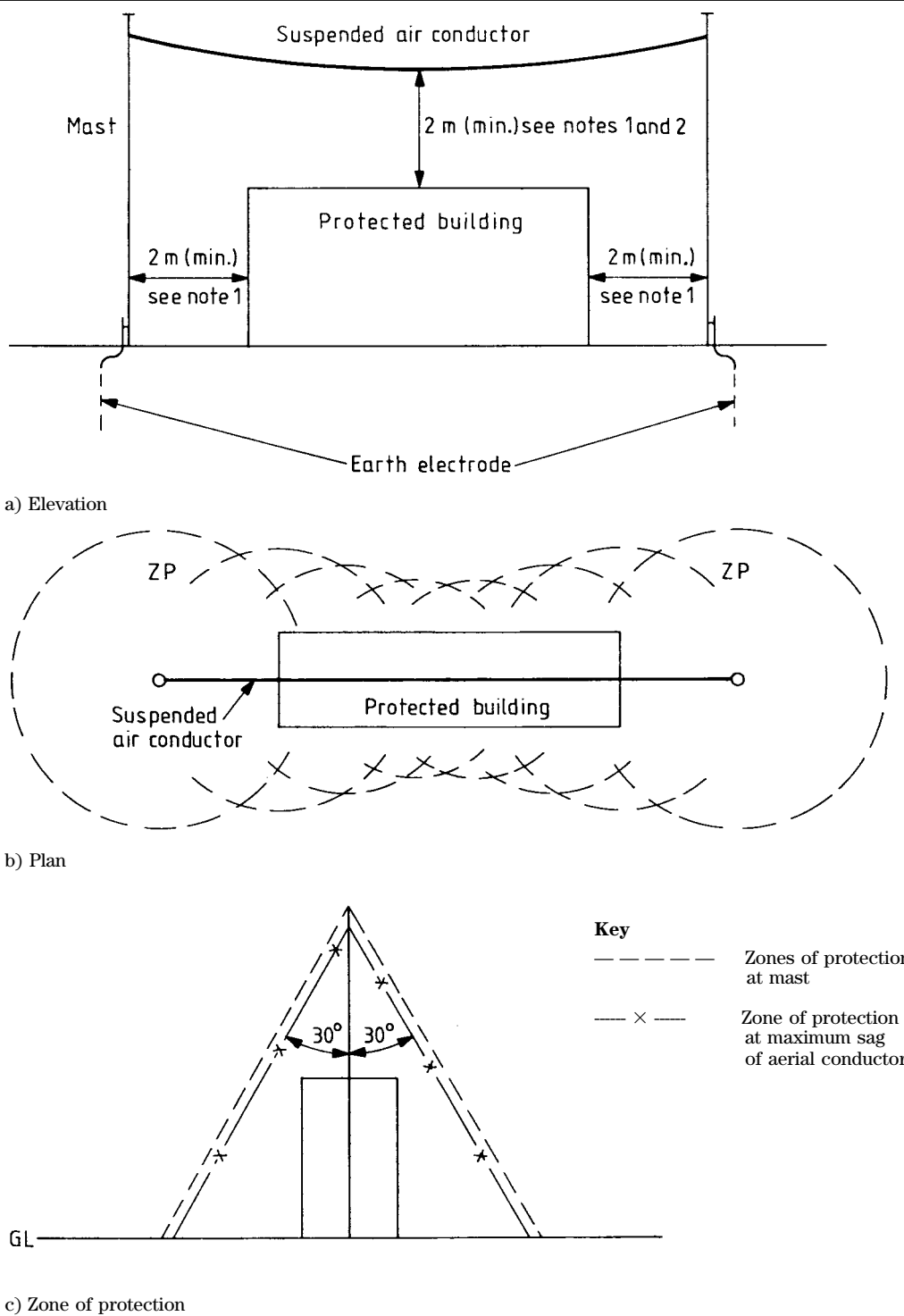

NOTE 1 To prevent flashover between mast/conductor and protected building, the minimum clearance distance has to be 2 m or as governed by 19.2, whichever is the greater.

NOTE 2 This clearance has to be as given in note 1, under maximum sag conditions, i.e. snow and ice on the aerial conductor.

Figure 18 — Air termination and zone of protection for simple structure with explosive or highly flammable contents

16.2 Pattern of down conductors

Various types of structures, with and without steel frames, are shown in Figure 19.

In high rise structures, the steel frame or reinforcement of the concrete, all of which should be interconnected, participate in the discharge of a lightning current together with all vertical pipes and the like, which should be bonded top and bottom.

The design of a lightning protection system will therefore include continuous columns or stanchions that are spaced in accordance with 16.3. No separate down conductors are needed on buildings with a steel frame or of reinforced concrete construction.

Figure 19a) represents a steel framed building. No added down conductors are therefore needed but earthing is essential in accordance with this code of practice. Figure 19b) shows a down conductor pattern where the upper floors are cantilevered on the north, east and south sides. Figure 19c) shows a pattern where a ballroom and/or swimming pool and terrace (for example) are situated on the south and west sides.

Figures 19d) to 19g) show buildings of such a shape as to permit all down conductors to be positioned on the outside walls. Care should be taken to avoid entrance and exit areas by an appropriate choice of down conductor spacing, taking account of the need to avoid dangerous voltage gradients along the ground surface. See also Figure 20.

16.3 Recommended number

The position and spacing of down conductors on large structures is often governed by architectural convenience. However, there should be one down conductor for each 20 m or part thereof of the perimeter at roof level or ground level, whichever is the greater. Structures over 20 m high should have one per 10 m or part thereof.

16.4 Tall structures presenting inspection difficulties

For tall structures, where testing and inspection are potentially difficult, consideration should be given to providing a means for testing the continuity of the system. At least two down conductors will be needed for such tests (see Figure 5).

16.5 Routeing

A down conductor should follow the most direct path possible between the air termination network and the earth termination network. Where more than one down conductor is used, the conductors should be arranged as evenly as practicable around the outside walls of the structure starting from the corners (see Figure 19) subject to architectural and practical constraints.

In deciding the route, consideration should be given to the incorporation of structural steelwork, i.e. stanchions, reinforcement and any continuous and permanent metal parts of the structure that are suitably disposed, into the down conductor.

The walls of light wells and enclosed courtyards may be used for fixing down conductors but lift shafts should not be used (see BS 5655 and 19.3.10).

Enclosed courtyards should be provided with a down conductor every 20 m. However, there should be a minimum of two down conductors and they should be spaced symmetrically.

16.6 Use of reinforcement in concrete structures

16.6.1 General

Details should be decided at the design stage, before building construction begins [see 13.6l)].

16.6.2 Electrical continuity

The metal bars of a reinforced concrete structure cast in situ are occasionally welded, thus providing definite electrical continuity. More frequently they are tied together by metal binding wire at crossing points. However, despite the fortuitous nature of the metallic connection, the very large number of bars and crossing points of such a construction assures a substantial subdivision of the total lightning current into a multiplicity of parallel discharge paths.

Experience shows that such a construction can be readily utilized as part of the lightning protection system.

NOTE BS 4485-4 provides recommendations for hyperbolic and mechanical draught cooling towers of reinforced concrete construction.

However, the following precautions are recommended:

- a) good contact between reinforcing bars should be ensured, i.e. by fixing the bars with tying wire;
- b) ties should be provided for both vertical to vertical bars and horizontal to vertical bars.

16.6.3 Electrolytic corrosion

A number of reports have been written concerning the corrosion of steel in concrete. This has a bearing upon the use of reinforcement in a lightning protection system with an attendant risk of accelerated corrosion.

Although there has been concern about the risk of accelerated corrosion of steel in concrete, examination of reinforced concrete structures, including water cooling towers (see BS 4485-4), in the UK over many years, has revealed no problems associated with this. The continued use of steel reinforcement as part of lightning protection systems is therefore recommended.

It should be remembered that the reinforcement is fully encapsulated in concrete and connection to it is made above the ground (see Figure 7). This practice lessens the chance of ingress of water and provides a simple means of disconnecting the reinforcement from the system should this be necessary.

NOTE In water cooling towers (see note to 16.6.2), it is usual to rely entirely upon the reinforcement. Experience has shown that, although some spalling of the concrete of the coping may occur when the tower is struck, there is no significant structural damage.

16.6.4 Pre-stressed concrete members

Lightning protection conductors should not be connected to pre-stressed concrete columns, beams or braces where the wires or strands are not linked and therefore not electrically continuous.

16.6.5 Pre-cast concrete members

In the case of pre-cast reinforced concrete columns, beams or braces, the reinforcement may be used as a conductor if the individual elements of reinforcement are bonded together and electrical continuity is ensured.

16.7 Internal routes

Where the provision of suitable external routes for down conductors is impractical or inadvisable (see **16.8.3**), down conductors may be housed in an air space provided by a non-metallic, non-combustible internal duct and taken straight down to ground level (see Figure 21).

Any suitable covered recess, service duct, pipe or trunking running the full height of the building may be used for this purpose provided that it does not contain any cables.

16.8 Sharp bends and re-entrant loops

16.8.1 Practical reasons do not always allow the most direct route to be followed. Whilst sharp bends, such as those that arise at the edge of a roof, are permissible, re-entrant loops in a conductor can produce high inductive voltage drops so that the lightning discharge may jump across the open side of the loop. As a rough guide, this risk may arise when the length of the conductor forming the loop exceeds the width of the open side of the loop by a multiple of eight (see Figure 22).

16.8.2 When large re-entrant loops cannot be avoided, e.g. in the case of some cornices or parapets, the conductor should be arranged in such a way that the distance across the open side of a loop conforms to the principle given in **16.8.1**. Alternatively, such cornices or parapets should be provided with holes through which the conductor can pass freely.

16.8.3 In buildings with cantilevered upper floors, the risks of side-flashing from external down conductors to persons standing under the overhang should be considered. Down conductors should be routed internally, in accordance with **16.7**, if the dimensions of the overhang are such that there is a risk to persons of side-flashing or if the spacing of the down conductors is greater than 20 m.

The risk to persons is unacceptable if the height, h , of the overhang is less than 3 m. For overhangs equal to or greater than 3 m, the width, w , of the overhang should be less than or equal (in metres) to that given by the expression:

$$w \leq 15(0.9h - 2.5) \quad (3)$$

if down conductors are to be routed externally. The application of h and w to an overhang is illustrated in Figure 22d).

NOTE The above formula has been derived from IEC 61024-1:1990, **3.2** and IEC 61024-1-2 *Guide B*, assuming design criteria of Protection Level 1, down conductor spacings of 20 m, a two-dimensional configuration of lightning protection conductors and a flashover medium of air between the down conductors and persons in the vicinity of the building.

16.9 Bonding to prevent side-flashing

Any metal in or forming part of the structure or any building services having metallic parts which either by design or fortuitously are in contact with the general mass of the earth should be either isolated from or bonded to the down conductor (see clause **19**). However, unless the calculations in **19.2** and the considerations of **A.2** indicate that extra bonding is required, items already in metallic contact with the lightning protection system, directly or indirectly, through permanent and reliable metal-to-metal joints do not need additional bonding conductors.

The same general recommendation applies to all exposed large metal items whether connected to earth or not.

NOTE In this context, a large item is considered as one having any single dimension greater than 2 m.

Minor items such as door hinges, metal gutter brackets and reinforcements of small isolated beams may be disregarded.

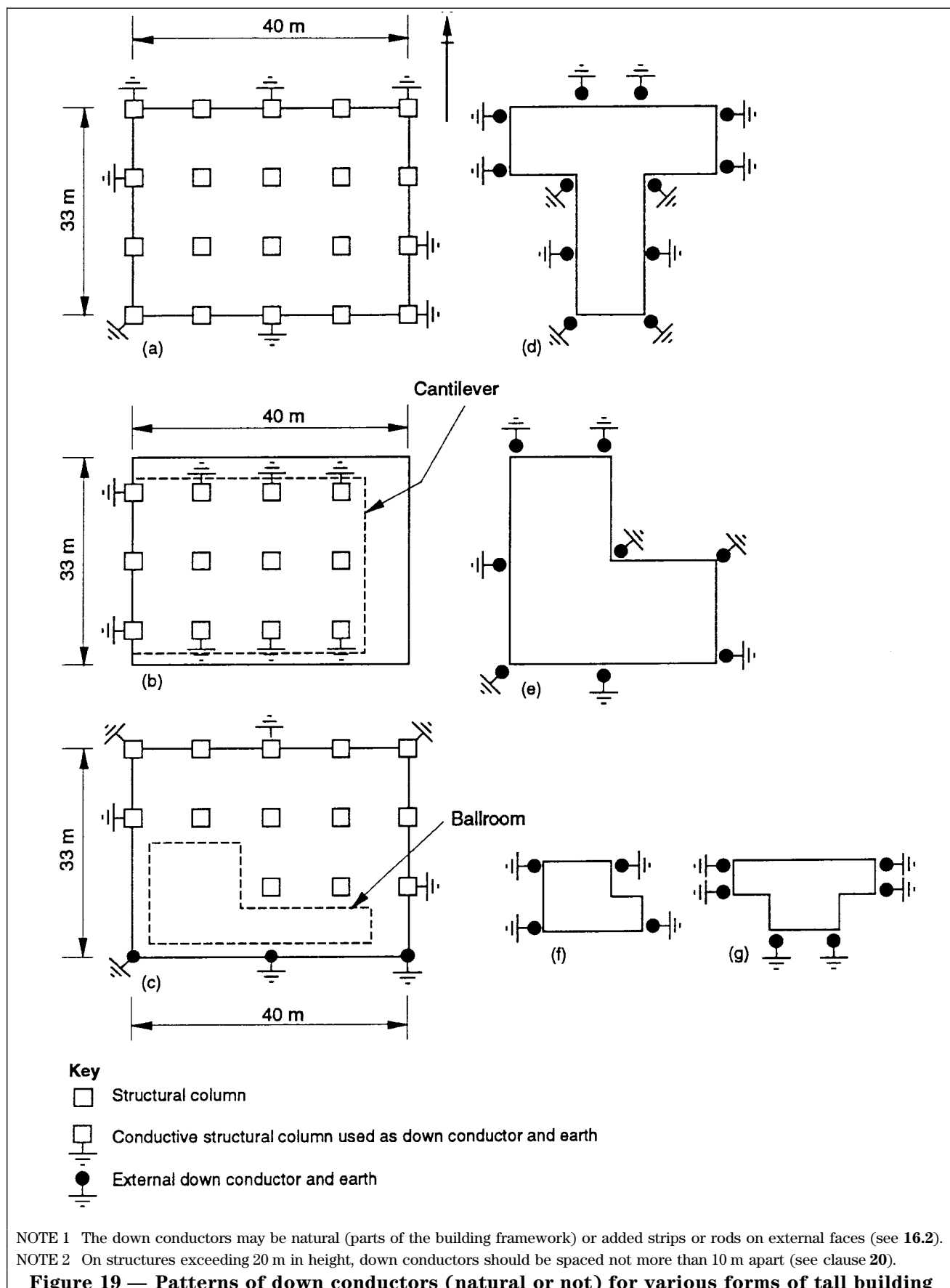

Licensed Copy: Puan Ms. Norhayati, Petroliam Nasional Berhad 4397000, 03 July 2003, Uncontrolled Copy, (c) BSI

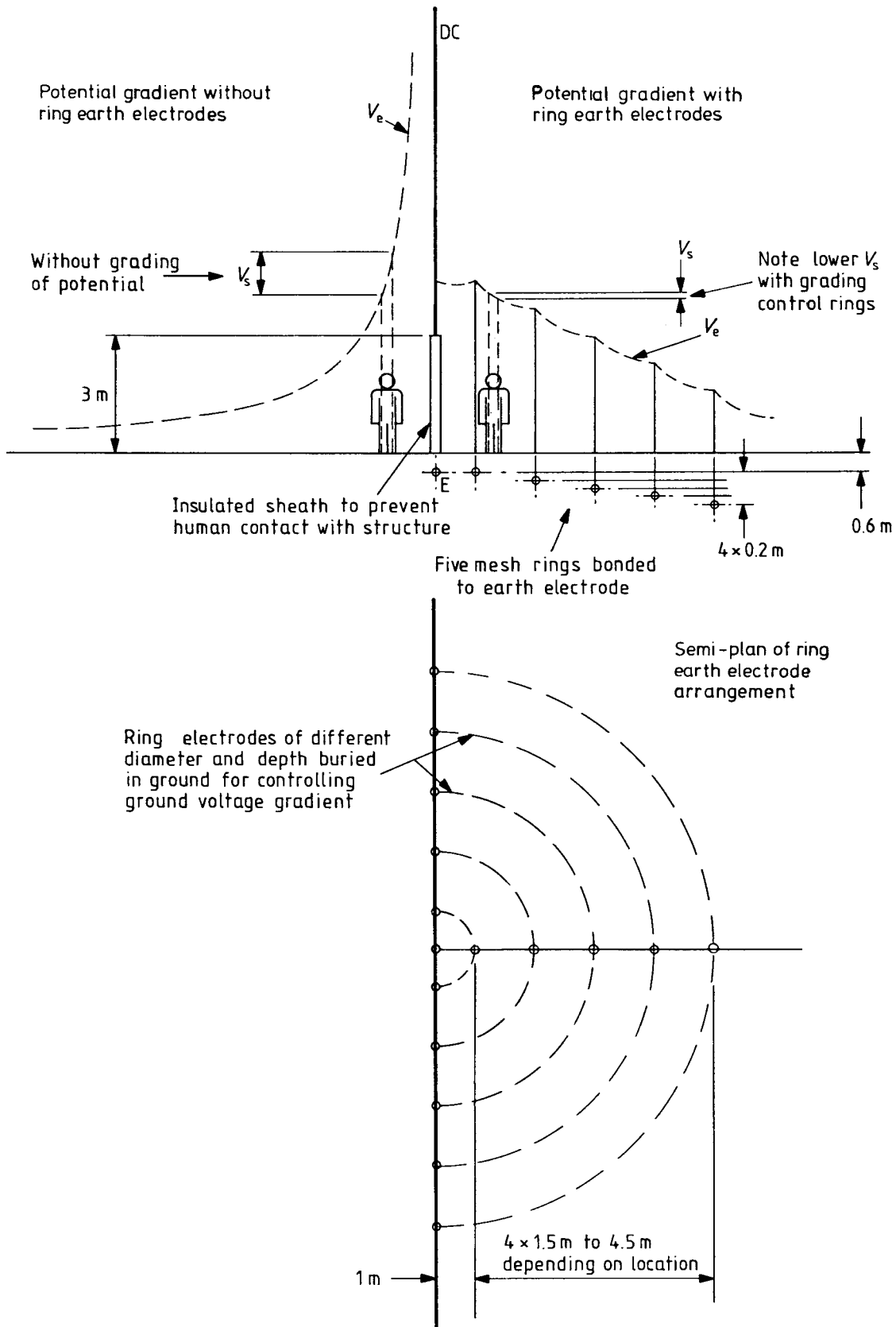
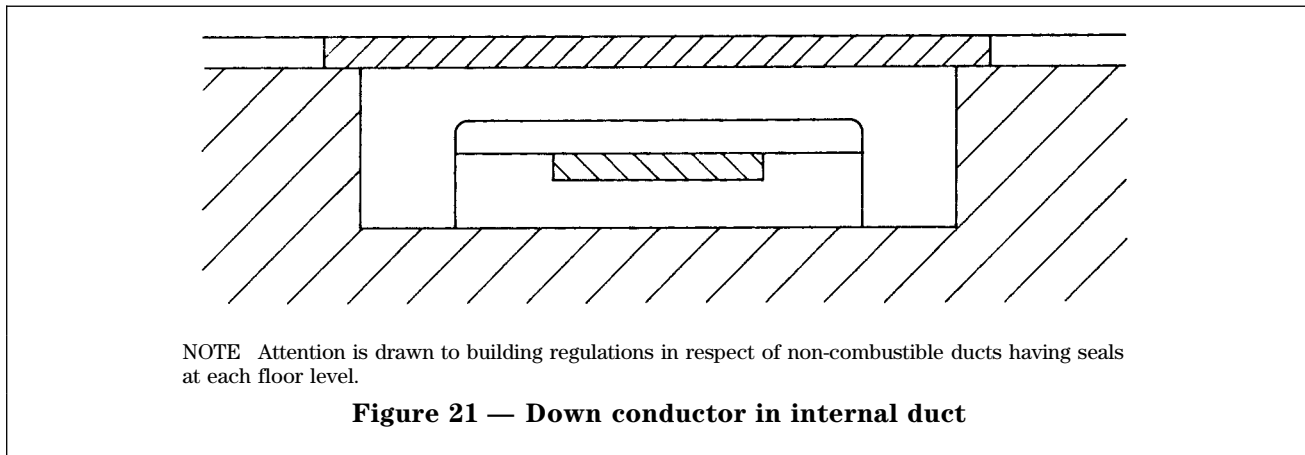
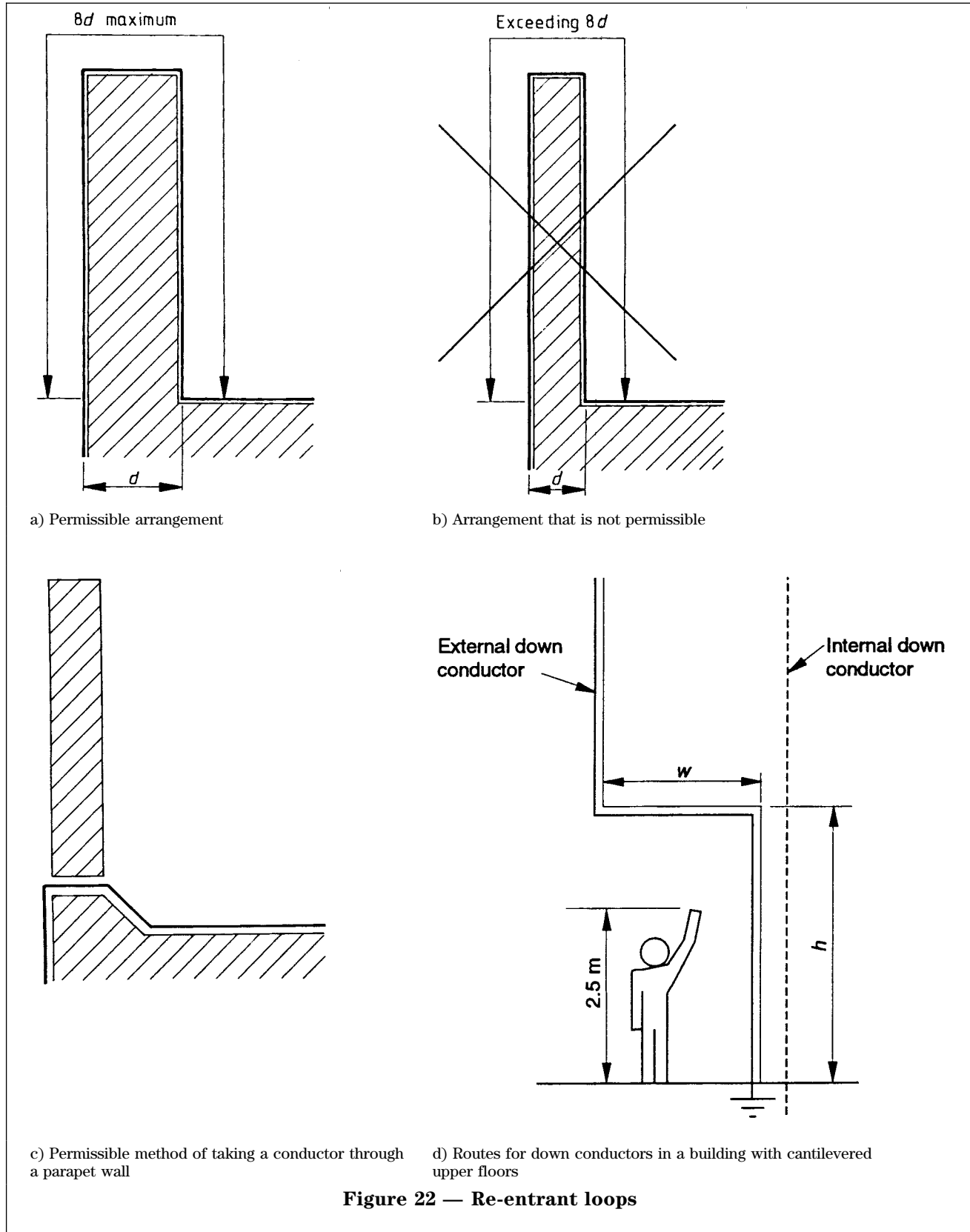

Figure 20 — Voltage gradients along ground surface near to masts, towers and columns with single multiple earth electrodes (see 16.2 and A.1.2)





16.10 Bonds

16.10.1 General

Most parts of a lightning protection system are specifically designed to fit into an overall plan. Bonds, however, are used to join a variety of metallic parts of different shapes and compositions and cannot therefore be of standard form. Because of their varied use and the risk of corrosion, careful attention needs to be given to the metals involved, i.e. that of the bond and of the items being bonded. In considering the choice of metals, guidance can be obtained from PD 6484.

16.10.2 Mechanical and electrical requirements

A bond should be mechanically and electrically effective and protected from corrosion in, and erosion by, the operating environment.

External metal on, or forming part of, a structure may have to discharge the full lightning current and its bond to the lightning protection system should have a cross-sectional area not less than that employed for the main conductors. On the other hand, internal metal is not nearly so vulnerable and its associated bonds are, at most, only likely to carry a proportion of the total lightning current, apart from their function of equalizing potentials. These latter bonds may therefore be smaller in cross-sectional area than those used for main conductors (see Table 4).

16.10.3 Provision for bonding of future equipment

In all buildings, at each floor level, provision should be made for bonding future machinery or equipment to the lightning protection system, i.e. by connection to metallic gas, water, drainage or similar services or as set out in BS 7671. Structures supporting an overhead electric supply, telephone and other lines should not be bonded to a lightning protection system without the permission of the appropriate authority.

16.10.4 Joints

Any joint other than one of welded type represents a discontinuity in the current conducting system and is susceptible to variation and failure. Accordingly, the lightning protection system should have as few joints as possible.

Joints should be mechanically and electrically effective, e.g. clamped, screwed, bolted, riveted or welded. With overlapping joints, the overlap should be not less than 20 mm for all types of conductor. Contact surfaces should first be cleaned and then inhibited from oxidation with a suitable non-corrosive compound. Bimetallic joints should be effectively cleaned using a separate abrasive for each type of material.

All joints should be protected against corrosion or erosion by the environment and should present an adequate contact area. Periodic inspection is facilitated by the use of protective coatings of:

- a) petroleum-wax-based thixotropic; or
- b) aerosol sprayed rubberized coatings; or
- c) heat-shrunk clear sheathing.

Guidance on bimetallic joints is given in PD 6484.

The materials used for nuts and bolts should be in accordance with Table 2. For bolting flat strip, the minimum requirement is two M8 bolts or one M10 bolt. For riveted joints, at least four rivets of 5 mm diameter should be used.

Bolted connections of flat strip to sheet metal of less than 2 mm thickness should be shimmed for an area of not less than 10 cm², and not less than two M8 bolts should be used.

16.11 Test points

Each down conductor should be provided with a test joint in such a position that, whilst not inviting unauthorized interference, it is convenient for tests.

Plates indicating the position, number and type of earth electrodes should be fitted above each test point.

17 Earth termination network

NOTE Additional information on earth termination networks is included in A.1.

17.1 Resistance to earth

An earth electrode should be connected to each down conductor. Each of these earths should have a resistance (in ohms) not exceeding the product given by 10 times the number of earth electrodes to be provided (see 16.3). The whole of the earth termination network should have a combined resistance to earth not exceeding 10 Ω without taking account of any bonding to other services.

The resistance to earth before and after the completion of bonding should be noted and used in all subsequent testing (see 17.4 and clause 32).

If the value obtained for the whole of the lightning protection system exceeds 10 Ω , a reduction can be achieved by extending or adding to the electrodes or by interconnecting the individual earth electrodes of the down conductors by a conductor installed at least 0.6 m below the ground, sometimes referred to as a ring earth electrode (see Figure 23). Ring earth electrodes should preferably pass below incoming services.

Buried ring earth electrodes laid in such a manner are considered to be an integral part of the earth termination network and should be taken into account when assessing the overall value of resistance to earth of the installation.

In a steel framed structure, the members of the steel frame are normally sufficiently well bonded together to serve as the down conductors. The lower end of the structure should be adequately earthed, with down conductors spaced in accordance with **16.3**. In most instances, the foundations of the building will have an adequately low earth resistance without additional earth electrodes, particularly if the building foundation includes reinforced piles. A measurement of the earth resistance of the newly completed foundations will establish whether these are adequate alone or whether further earth electrodes should be added (see **A.1.6**). In existing structures, the measurement of the foundation resistance to earth may be impractical and therefore alternative means of earthing should be sought, as discussed in clause **18**. If the foundation alone is to be used, provision should be made to bond each vertical member of the steel structure to the earth matrix of the foundation concrete reinforcing bars.

17.2 Importance of reducing resistance to earth

A reduction in the resistance to earth to a value below $10\ \Omega$ has the advantage of reducing the potential gradient around the earth electrodes when discharging lightning current. It may also reduce the risk of side-flashing to metal in or on a structure (see **16.9**).

17.3 Common network for all services

A common earth termination network is recommended for the lightning protection system and all other services. It should be in accordance with the recommendations of this code of practice and should also comply with any regulations applicable to the services concerned. The resistance to earth should, in this case, be the lowest value needed for any of the individual services.

17.4 Isolation of earth electrode systems for testing

Earth electrodes should be capable of being isolated and a reference earth electrode (see **3.1.12**) should be provided for testing purposes.

Where the steel structure of a building is used as the down conductors, sufficient points of test should be provided to enable the low resistance continuity of the steel structure to be checked. This is especially important for those parts of the structure that are not visible. A reference earth electrode will be necessary for these tests.

17.5 Structures on rock

A structure standing on rock should be provided with a ring earth electrode which follows the contour of the ground. If there is earth cover, it should be used. This conductor should be installed under the foundation of a new structure. If there are objections to these recommendations, at least two strip electrodes should be used, or an earth termination can usually be obtained by rock drilling and backfilling the hole with a conducting material such as bentonite or a conductive concrete or cement made with graded granular carbonaceous aggregate in place of the conventional sand or aggregate. The diameter of the hole should be not less than 75 mm. Coke breeze or fly ash should not be used as backfilling material because of their corrosive nature. The value of $10\ \Omega$ for the resistance to earth is not applicable in this case.

18 Earth electrodes

NOTE Additional information on earth electrodes is included in **A.1**.

18.1 General

Before proceeding with a design, a decision on the form of earth electrode most suited to the physical nature of the soil as revealed by trial bore holes is necessary.

Earth electrodes should consist of metal rods, tubes or strips or a combination of these or natural earths such as piles and foundations (see **A.1.4** and **A.1.6**).

18.2 Ground conditions

18.2.1 General

Where earth rods are used, they should, except in rock (see **17.5**), be driven into ground neither made up nor backfilled, nor which is likely to dry out (either seasonally, or due to heat from boilers or plant).

18.2.2 Earth electrode seal for use within a tanked structure

When earth terminations in built-up areas pass through a tanked structure, a seal similar to that shown in Figure 24 should be used.

18.3 Earth rods

18.3.1 Location

When earth rods are used, they should be driven into the ground beneath, or as close as practicable to, the structure and down conductor. The practice of siting terminations away from the building is normally unnecessary and uneconomical (see Figure 25).

Where ground conditions are favourable for the use of rods in parallel, the reduction in earth resistance is small when the separation between the rods becomes less than their driven length.

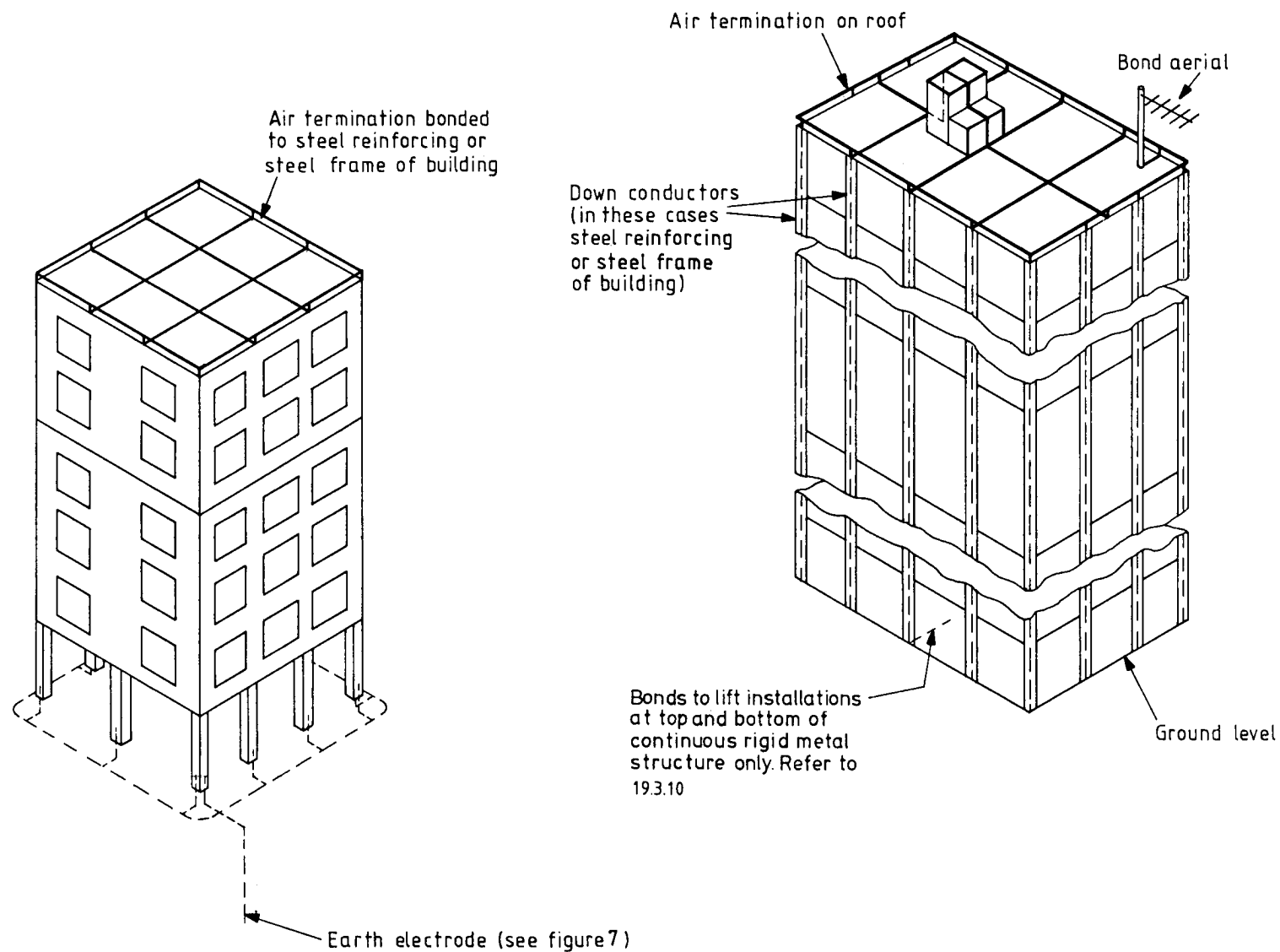

Figure 23 — Lightning protection system for tall buildings (over 20 m high) showing air terminations, down conductors, bonds to projections above roof

18.3.2 *Electrical measurements during installation*

During the driving of the rods, it is advisable to take measurements of the resistance to earth. By so doing, an indication will be given of conditions under which it is highly unlikely that any further reduction in resistance will be obtained even where a greater length of rod is to be driven into the ground.

18.3.3 *Connections*

The point of connection to the earth termination network should be removable and easily accessible from above the ground to facilitate inspection, testing and maintenance of the lightning protection system.

If below the ground, the point of connection should preferably be housed in a purpose-built inspection pit or chamber. However, simpler arrangements or even none at all may be acceptable in some circumstances, e.g. small installations, deeper-than-normal earth termination networks, or for other reasons dictated by site conditions (see A.1.2).

18.4 Strips

18.4.1 *Position and form*

When strips, mats or plates are used, they may be buried beneath the structure or laid in trenches at depths unlikely to be affected by seasonal drying out or agricultural operations.

Strips should preferably be disposed radially from the point of connection with a down conductor and the numbers and lengths of strip needed should be determined such that the desired resistance to earth is obtained.

If space restrictions demand the use of a parallel or grid formation of strips, the layout should be as in Figure 25 where the distance between parallel strips should be not less than 3 m.

18.4.2 *Corrosion*

Because of the harmful corrosion which is likely to result, coke breeze should not be allowed to be in contact with copper electrodes, and salting of the ground in the vicinity of any earth electrode is inadvisable.

19 Metal in or on a structure

NOTE Additional information on metal in or on a structure is included in A.2.

19.1 General

When a lightning protection system is struck, its electrical potential with respect to earth is raised and, unless suitable precautions are taken, the discharge may seek alternative paths to earth by side-flashing to other metal in the structure.

There are two ways of preventing side-flashing, namely:

- a) isolation;
- b) bonding.

Isolation requires large clearances between the lightning protection system and other metal in the structure. The main drawbacks to isolation lie in the difficulty in obtaining and maintaining the necessary safe clearances and in ensuring that isolated metal has no connection with the ground, e.g. through water or other services.

In general, bonding is the more commonly used method.

19.2 Isolation

19.2.1 *Estimation of clearances to prevent side-flashing*

19.2.1.1 *General*

The necessary clearance to prevent side-flashing depends upon the voltage sustained by the lightning protection system with respect to earth, which in turn depends upon the strength of the current in the lightning flash. The procedure for estimating the necessary clearance is given in 19.2.1.2 to 19.2.1.4.

NOTE It has been shown theoretically and experimentally that the electric and magnetic fields are the same for both a "shielded" down conductor and a conventional system of similar size. The shielded conductor has the disadvantage that, at its top, potentials of up to hundreds of kilovolts can occur between the inner conductor and the outer conductor ("shield"), so triggering a side-flash. A further disadvantage is that the inner conductor is not accessible for inspection.

19.2.1.2 *Determination of expected current*

To determine the current in the lightning flash, the following steps should be taken.

- a) The risk of the structure being struck p (see 10.2) is estimated.
- b) The estimated risk, p is divided by the acceptable risk, p_0 , (see 10.3 and 10.4).
- c) Using Figure 26, the maximum current likely to occur is determined.

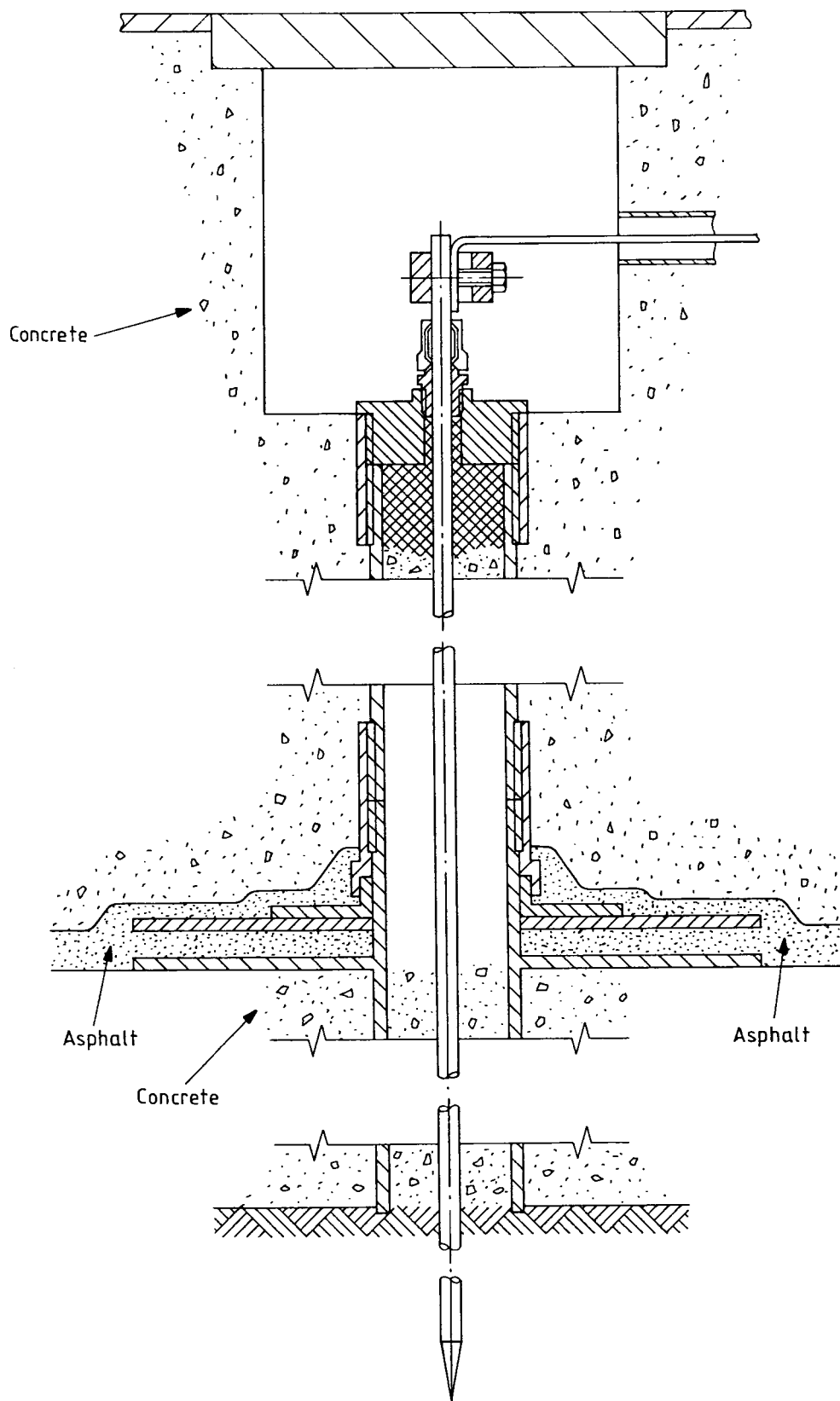
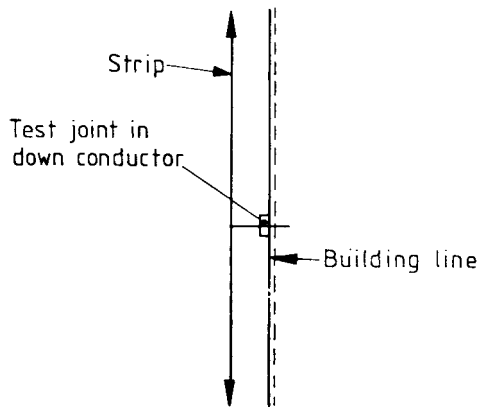
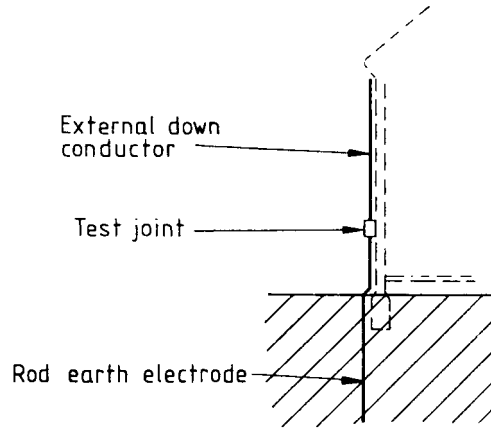

Figure 24 — Example of an earth electrode seal for use within a tanked structure



Plan arrangement for single strip bisected by down conductor



Section and elevation of structure

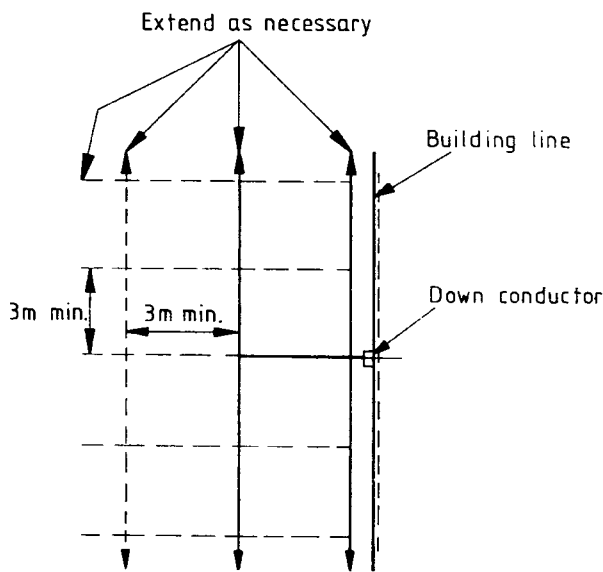

Plan arrangement of strips in parallel (continuous heavy line) or grid formation (broken line)

(a) Strip electrodes

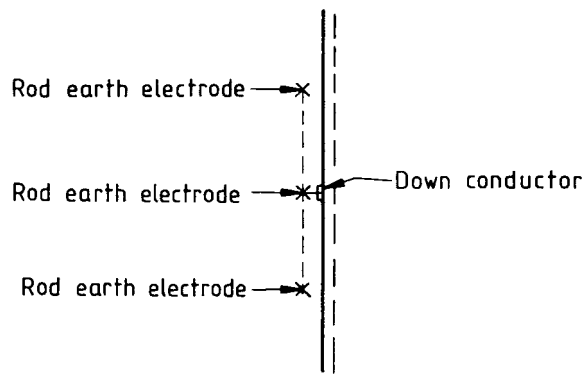

Plan arrangement

(b) Single or multiple rod electrodes

NOTE 1 When it is necessary for part of an earth termination network to pass near or under a road or pathway, it should be buried not less than 0.6 m below ground level.

NOTE 2 The electrical potential at ground level can be reduced by burying the rod or strip deeper.

Figure 25 — Earth terminations: arrangement of earth electrodes

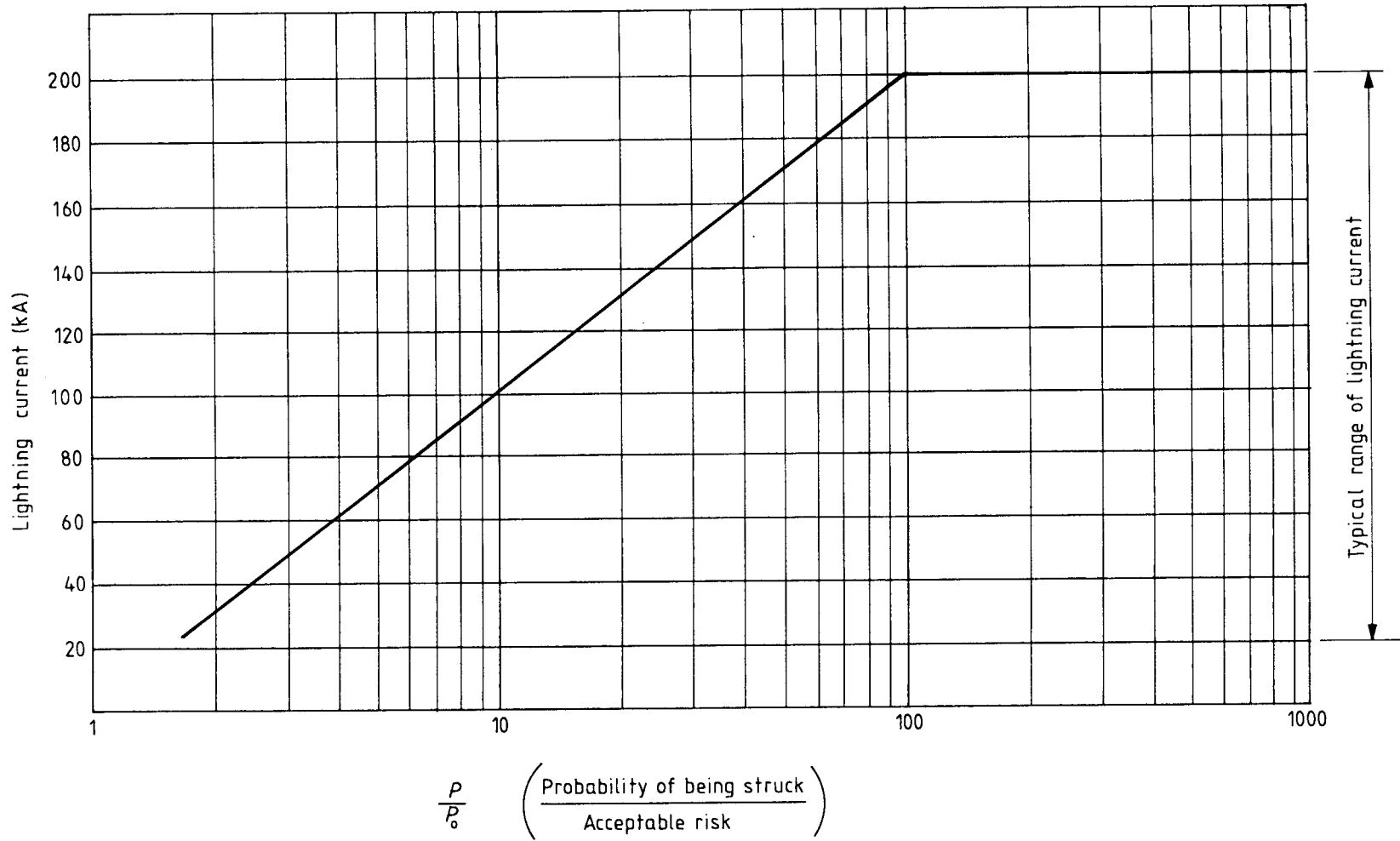

Figure 26 — Curve for determining the probable maximum current in the lightning flash from the ratio p/p_0

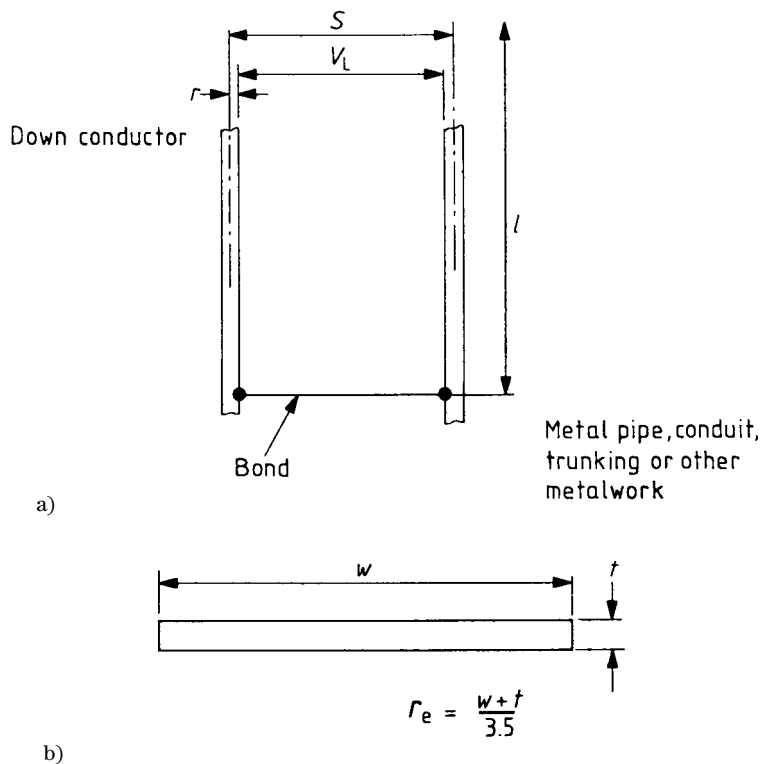

Figure 27 — Transfer inductance in simple loop

19.2.1.3 Voltage sustained by lightning protection system

This has two components; one is the product of the current and the resistance to earth and the other is the product of the rate of change of current and the inductance of the down conductor. In the worst case, the simple addition of these two products gives the voltage which should then be used in calculations.

19.2.1.4 Calculation of inductively generated voltages between a lightning conductor and other metalwork susceptible to side-flashing

Although hitherto the term “self-inductance” has been used for this calculation, in practice the induced voltage arises in a loop formed by the down conductor itself and the other metalwork, so strictly the coupling is generated by the self-inductance (L) minus the mutual inductance (M) to this metalwork. This quantity is termed the transfer inductance (M_T) and replaces the self-inductance for this type of inductively generated voltage calculation. It is readily calculated using equation (4).

For a vertical lightning conductor with a circular cross-section of radius r (in metres), separated from another vertical metal component by a distance S (in metres), where S is the distance between the centres of the two conductors as shown in Figure 27a) and l is the vertical height of the loop, the transfer inductance M_T (in microhenries) is given by the equation:

$$M_T = 0.46 \times l \times \log_{10} \frac{S}{r} \quad (4)$$

For non-circular down conductors, an effective radius (r_e) should be used [see Figure 27b)]. For example, for a strip of cross-sectional dimensions $25 \text{ mm} \times 3 \text{ mm}$, r_e (in metres) is given by equation (5) below:

$$\begin{aligned} r_e &= \frac{w + t}{3.5} \\ &= \frac{0.025 + 0.003}{3.5} \\ &= 0.008 \end{aligned} \quad (5)$$

The calculation of M_T is unaffected, however, by the cross-sectional shape of the metal pipe or other metalwork. Having obtained M_T , the inductive voltage V_L (in kilovolts) generated in the loop shown in Figure 27a) is given by equation (6):

$$V_L = \left(\frac{di}{dt} \right)_{\max} \times \frac{M_T}{n} \quad (6)$$

where

$\left(\frac{di}{dt} \right)_{\max}$ is the maximum rate of change of current (in $\text{kA}/\mu\text{s}$), i.e. $200 \text{ kA}/\mu\text{s}$ (see 4.2.1);

n is the number of down conductors which simultaneously share the lightning current.

Where there are several down conductors, the distance S from the lightning conductor to the nearest down conductor should always be used.

For example, using equation (6), if $S = 1 \text{ m}$, $r = 0.008 \text{ m}$, $l = 5 \text{ m}$ and $n = 4$:

$$V_L = 200 \times \frac{0.46 \times 5 \log_{10} (1/0.008)}{4}$$

$$V_L = 240 \text{ kV}$$

From Figure 28, a spacing at the top of the loop (perhaps a side arm from the metalwork) to the down conductor would have to be as small as 0.4 m locally to create a flashover danger. Such a side arm, if so close, should be bonded to the down conductor for safety.

In rectangular or square buildings with more than four down conductors, the corner down conductors take a disproportionately large share of the total current (i) (i.e. $> i/n$), so a factor of 30 % should be added to the voltage generated near such a conductor.

Conversely, in the central area of buildings having many down conductors (i.e. away from the corner down conductor), the value of di/dt is lower than that given by the number of down conductors by approximately 30 % and side-flashing is a relatively minor danger, assuming all services are bonded so that the earth resistances do not create potential differences.

19.2.1.5 Flashover voltage in relation to spacing

The flashover voltage for the given spacing should be read from Figure 28 for comparison with the calculated inductive voltage.

19.2.2 Example of calculation

The following is an example of the calculation necessary to decide whether or not to bond metalwork to a lightning protection system.

Situation. A cast steel down pipe is positioned 2 m from the down conductor of the lightning protection system fitted to a block of flats 15 m high situated in a region of high lightning activity, having 1.2 flashes per square kilometre per year. The block of flats is $40 \text{ m} \times 20 \text{ m}$ in plan (see Figure 29).

Assumptions. It is assumed that the acceptable risk, p_o , is 10^{-5} , that the resistance of the earth termination will be 10Ω and that the number of down conductors is six.

Problem. To decide whether or not the down pipe, which has a maximum height of 12 m, should be bonded to the lightning protection system.

Procedure. The plan of the collection area is as follows:

$$L = 40 \text{ m}, W = 20 \text{ m} \text{ and } H = 15 \text{ m}.$$

Collection area. Determined using equation (1):

$$\begin{aligned} A_c &= LW + 2LH + 2WH + \pi H^2 \\ &= (40 \times 20) + 2(40 \times 15) + 2(20 \times 15) + (\pi \times 225) \\ &= 800 + 1\,200 + 600 + 707 \\ A_c &= 3\,307 \text{ m}^2 \text{ (say } 3\,300 \text{ m}^2) \end{aligned}$$

Probability of being struck. Determined using equation (2):

$$\begin{aligned} p &= A_c \times N_g \times 10^{-6} \\ &= 3\,300 \times 1.2 \times 10^{-6} \\ p &= 3.96 \times 10^{-3} \text{ strikes per year} \\ &\text{(say } 4 \times 10^{-3} \text{ or once in 250 years)} \end{aligned}$$

Determination of current in lightning flash.

$$\begin{aligned} \frac{p}{p_o} &= \frac{(4 \times 10^{-3})}{10^{-5}} \\ &= \text{say } 4 \times 10^2 \\ &= 400 \end{aligned}$$

Because p is greater than $100p_o$, it should be assumed that the maximum lightning current of 200 kA will be achieved (see Figure 26).

NOTE For values of p/p_o less than 100, the current will be $100 \log_{10} p/p_o$, as shown in Figure 26.

Voltage between lightning protection system and earthed down pipe at height of 12 m. Two cases are considered, i.e. with the metal pipe bonded and with the metal pipe not bonded to the earth termination at the ground, as follows.

a) *Pipe bonded to earth termination.* Resistive voltages can be neglected and the voltage between the lightning protection system and the earthed pipe equals the inductively-derived voltage ($V = V_L$). Assuming six conductors ($n = 6$), each down conductor is of dimensions 25 mm \times 3 mm ($r_e = 0.008$ m), the effective radius $r_e = 0.008$ m, the loop length $l = 12$ m and $S = 2$ m, if these values are applied to equations (4) and (6), V_L is given by:

$$\begin{aligned} V_L &= 200 \times 10^3 \times 12 \times \frac{0.46 \log_{10} (2/0.008)}{6} \\ &= 440 \text{ kV} \end{aligned}$$

From Figure 28, a spacing of 0.85 m is needed, plus an allowance for the corner position of 30 % giving a total of 1.1 m. The actual spacing is 2 m, therefore bonding is not needed at the top of the pipe.

b) *Pipe contacting the ground but with no bond between the pipe and the earth termination.* The total voltage sustained by the lightning protection system (V) is given by:

$$V = V_R + V_L \quad (7)$$

where

V_R is the resistive voltage developed in the earth electrode system.

V_L will remain the same as the value in case a) to which V_R should be added as follows:

$$V_R = \frac{200 \times 10^3}{6} \times 10 \times 6 \text{ (since each termination may have a resistance in ohms } (\Omega) \text{ of } n \times 10)$$

$$\begin{aligned} V_R &= 2 \text{ MV} \\ V &= 2 + 0.44 \\ &= 2.44 \text{ MV} \end{aligned}$$

From Figure 28, a spacing of 6 m is necessary for this voltage and therefore the pipe needs to be bonded to the lightning protection system at the top or the bottom to eliminate the resistive voltage. The foregoing calculations demonstrate that side-flashing voltages are critically dependent on the number of down conductors and the magnitude of the earth resistance.

Where 2 m (equal to S the separation distance) is used for assessing the flashover voltage from Figure 28, this implies that the closest approach of any metal connected to the pipe to any metal connected to the down conductor is 2 m. If, as in this case, the pipe has a 2 m separation from the down conductor but additionally has a side branch coming to within 1 m of the down conductor near the top, the 1 m dimension should be checked against Figure 28 and the lightning-produced voltage to ascertain if there is adequate clearance.

Figure 28 shows flashover voltages in air, across the face of masonry and through cracks in brickwork.

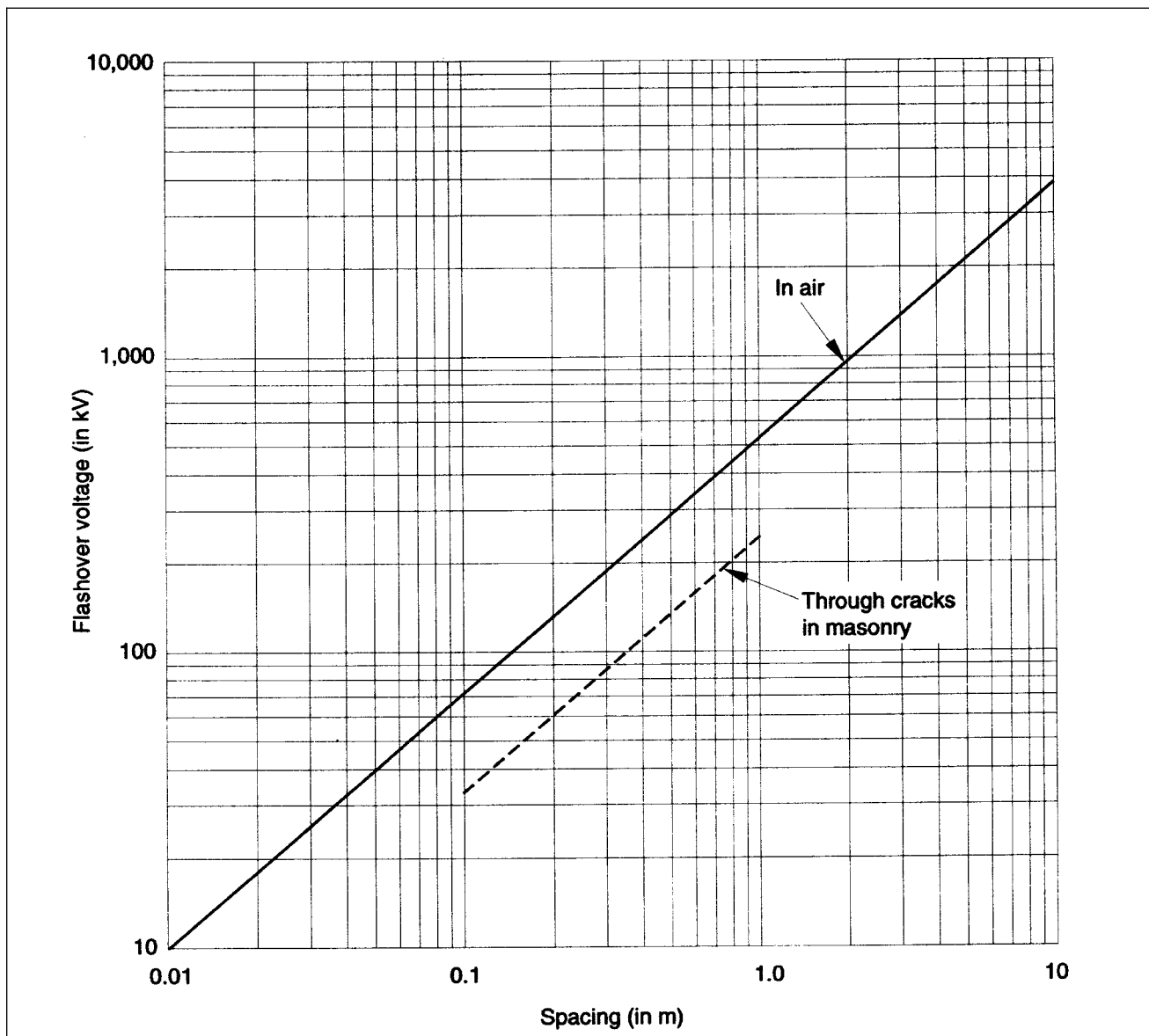

Figure 28 — Curve for determination of the flashover voltage as a function of spacing

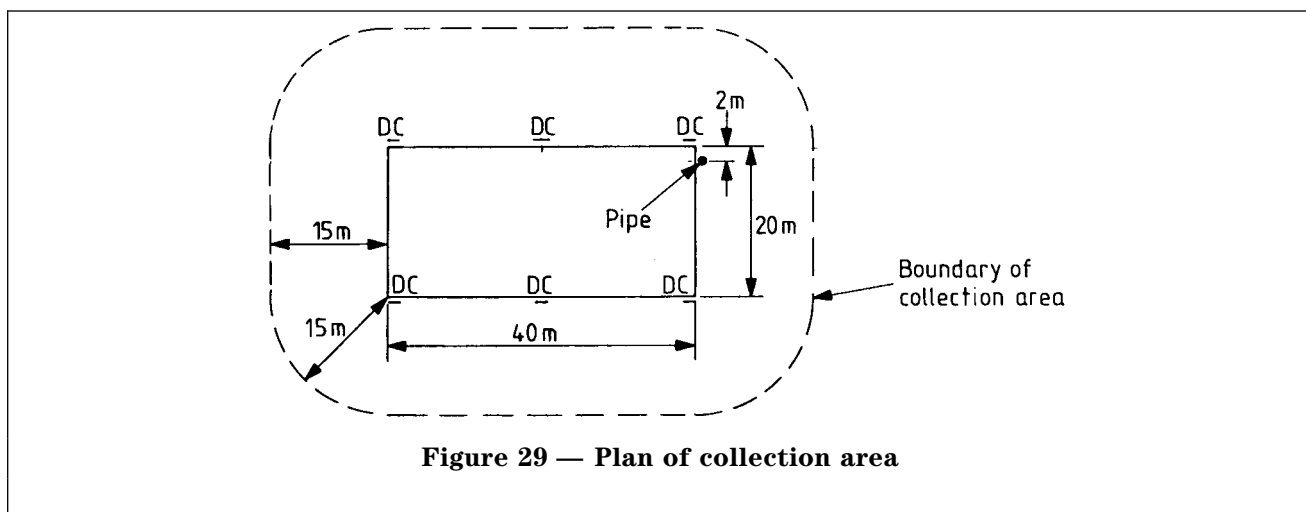

Figure 29 — Plan of collection area

19.3 Conditions where bonding is needed(see also **A.2**)

19.3.1 In bonding adjacent metalwork to the lightning protection system, careful consideration should always be given to the possible effects such bonding might have upon metalwork which has been cathodically protected. The recommendations of **19.3.2** to **19.3.10** should be taken into account.

19.3.2 Where a structure contains electrically continuous metal (e.g. a roof, wall, floor, metal cladding or curtain walling), this metal may be used as a component of the lightning protection system provided that the amount and arrangement of the metal render it suitable for use, as recommended in clauses **15** to **18**.

19.3.3 Where a structure is simply a continuous metal frame, no air termination or down conductor is necessary. It is sufficient to ensure that the conducting path is electrically and mechanically continuous and that the recommendations of the code of practice in respect of the connection to the general mass of the earth are met.

19.3.4 A reinforced concrete structure or a reinforced concrete framed structure may have sufficiently low inherent resistance to earth to provide protection against lightning. If connections are brought out from the highest points of the reinforcement during construction, a test may be performed to verify this on completion of the structure (see Figure 7).

If the resistance to earth of the steel frame of the structure or the reinforcement of a reinforced concrete structure is found to be satisfactory, a horizontal air termination should be installed at the top and bonded to the steel frame or to the reinforcement.

NOTE In the particular case of water cooling towers, it is not normal to fit an air termination, see BS 4485-4.

Where regular inspection is not possible, it is recommended that a corrosion resistant material be used for bonding to the steel or to the reinforcement and that this be brought out for connection to the air termination. Down conductors and earth terminations should, of course, be provided if the inherent resistance of the structure is found to be unsatisfactory when tested (see **17.1**).

19.3.5 Where metal exists in a structure and it cannot be bonded into a continuous conducting network and is not or cannot be equipped with external earthing connections, its presence should be disregarded. The danger resulting from the presence of such metal can be minimized by keeping this metal entirely isolated from the lightning protection system; due consideration should be given to the recommendations of **19.2**.

19.3.6 Where the roof structure is wholly or partly covered by metal, care should be taken that such metal is bonded to the lightning protection system.

19.3.7 In any structure, metal which is attached to the outer surface or projects through a wall or roof, has insufficient clearance from the lightning protection system and is unsuitable for use as part of it, should preferably be bonded as directly as possible to the lightning protection system. If the metal runs close to an air termination network, e.g. water mains to storage tanks in roofs, cables, pipes, gutters, rainwater pipes and stairways and if the metal runs approximately parallel to a down conductor or bond, it should be bonded at each end but not below the test point. If the metal is in discontinuous lengths, each portion should be bonded to the lightning protection system; alternatively, where the clearances permit, the presence of the metal may be disregarded.

19.3.8 Masses of metal in a building, such as a bell-frame in a church tower, all cladding, apparatus and equipment which is connected to, or in contact with, the mains water or electrical supplies and/or which is itself earthed should be bonded to the nearest down conductor by the most direct route available.

19.3.9 Metal entering or leaving a structure in the form of sheathing, armouring or piping for electric, gas, water, rain, steam, compressed air or any other service should be bonded as directly as possible to the earth termination. This should be done near to the point at which the service enters or leaves the structure. Dry risers should be similarly treated.

Where metal which forms part of services encroaches on the isolation distances (see **19.2**), it should be bonded to the nearest part of the lightning protection system at the highest point of the service and at intervals not exceeding 20 m.

No precise recommendations can be made because of the large variation in system designs. However, it should be noted that problems may arise where pipes or cables are protected with thermal or electrical insulation. In such cases, bonding should be made to the nearest point to where the metallic part of the pipe or cable becomes exposed. The bond should then be taken by as direct a route as practicable to the lightning earth outside the building.

This is more likely to apply in an insulated building to which the services are connected. However, where the building is surrounded by steelwork carrying an interconnected array of pipework, this in itself may well be a suitable point to which the earth connection should be made.

With regard to electricity supplies, the advent of combined neutral earth (CNE) cables introduces problems because a break in the neutral could result in the load current returning by way of the earth electrode. This would endanger anyone breaking the earth electrode circuit to make test measurements.

A typical system is shown in Figure 30. As a general rule, each system should be assessed on its merits and discussed with the authorities concerned.

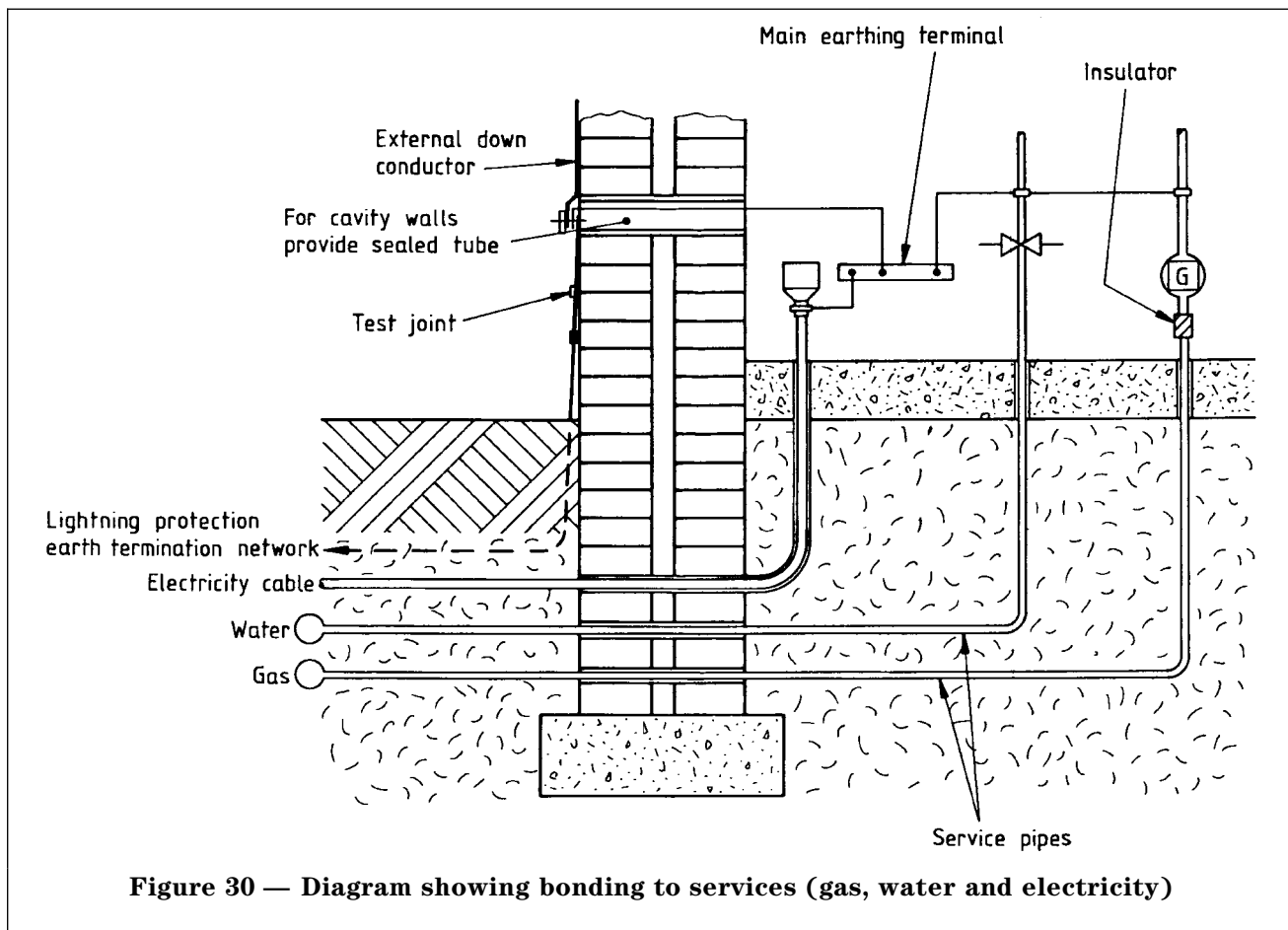

19.3.10 In lift installations, the continuous metal structure, including the guide rails, should be bonded to the lightning protection system at the top and bottom of the installation.

Where reinforcing or structural metalwork forms part of the lightning protection system, bonding to this metalwork is necessary.

Where it is either not possible or not practical to utilize the reinforcing or structural metalwork, or where no such metalwork exists, the installation should be bonded to the electrical safety earth at both the top and bottom of the installation. In each case, bonding should be to the earth point of the nearest distribution board.

20 Structures exceeding 20 m in height

NOTE Additional information on high structures is included in A.2 and A.5.

20.1 Non-conducting structures

On non-conducting structures, at least two equally spaced down conductors should be provided and it should be ensured, using the rolling sphere method (see A.5), that the air termination gives the desired zone of protection. On chimneys, the down conductors should be bonded to the metal cap of the chimney or to a conductor around the top of the chimney.

20.2 Conducting structures

The recommendations in the second paragraph of 19.3.4 are equally applicable to tall conducting structures but, where down conductors are needed, not less than two should be installed and these should be spaced not more than 10 m apart around the perimeter.

20.3 All types of stayed structure

Non-conducting and conducting structures which are supported by conducting stay-wires should be dealt with as described in 20.1 and 20.2 but, in addition, the upper ends of the stay-wires should be bonded to the lightning protection system and the lower ends earthed and interconnected by a buried ring earth electrode.

20.4 Church towers and spires

Lightning strikes below the highest points of tall structures are well authenticated and not less than two down conductors should be provided for all church towers and spires.

For non-conducting structures, an air termination network (see clause 15) should be designed to follow the construction contours of a tower; flagpoles and any other salient features above parapet level should also be included in the system. The remainder of the church should be protected in accordance with this code, with ridge, eaves and down conductors, earth termination networks and lightning protection potential equalization. Down conductors should not be fixed internally (see Figure 31).

Metal roofs may be suitable for use as air termination networks (see Table 5 and Figure 17).

21 Structures with roofs of high flammability

21.1 Air terminations

For structures with roofs of straw, reed, heather, grass or other highly combustible material, an air termination with a clearance of at least 0.3 m from the roof may be suspended from non-conducting and non-combustible supports or, alternatively, the air termination conductor may be laid on a hardwood strip at least 75 mm wide. Where wire netting is used to protect thatch and similarly-constructed roofs against wind and birds, it should not form part of the lightning protection system.

21.2 Conductors and bonds

Conductors or bonds which unavoidably penetrate the roofing material should be taken through non-conducting and non-combustible sleeves.

22 Buildings with explosive or highly flammable contents

22.1 General

Problems arising in the provision of lightning protection systems for structures with explosive or highly flammable contents are preferably dealt with in consultation with specialists conversant with any relevant Statutory Acts or Regulations and codes of practice.

An acceptable risk may be present when the quantity of dangerous material is strictly limited, as in a laboratory or small store, or where the structure is sited in an isolated position or specifically designed to restrict the effects of a catastrophe.

Circumstances may also arise in which the dangerous materials are not exposed but are

completely encased in metal of an adequate thickness. Under these conditions, other than by ensuring adequate earthing, lightning protection may not be necessary at all. In other situations, the risk to life and property may be such that the provision of every means possible for protection from the consequences of a lightning discharge is essential. Accordingly, recommendations for such cases are set out in 22.2 and are applicable to structures in which explosive or highly flammable solids, liquids, gases, vapours or dusts are manufactured, stored or used or in which highly flammable or explosive gases, vapours or dusts may accumulate.

In the particular case of explosives magazines and magazines at factories in the UK licensed by the Health and Safety Executive under the Explosives Act 1875, lightning protection systems are required by virtue of Orders in Council 2 and 3 made under the Act, unless such magazines are specifically exempted in the licence. In the case of explosive stores licensed by the local authority under the Stores for Explosives Order 1951, a lightning protection system is required unless the quantity of explosives in the store does not exceed 150 kg.

22.2 Protective methods

22.2.1 Suspended air terminations

An air termination network should be suspended at an adequate height above the area to be protected. If one horizontal conductor only is used, the protective angle adopted should not exceed 30° (see Figure 18). If two or more parallel horizontal conductors are installed, the protective angle that is to be applied may be as much as 45° within the space bounded by those conductors but it should not exceed 30° outside that space (see Figure 32). The heights of the horizontal conductor(s) should be chosen according to the recommendations of 19.2 (see Figure 32); in cases of doubt, expert advice should be sought. The supports of the network should be adequately earthed.

Alternatively, where the expense of the preceding method would not be justified and where no risk would be involved in discharging the lightning current over the surface of the structure to be protected, either of the following arrangements would be suitable:

- a) a suspended air termination as shown in Figure 32 but where protection angles are deemed to be 45° instead of 30° and 60° instead of 45°;
- b) a network of horizontal conductors with a mesh of 10 m × 5 m or smaller according to the risk, fixed to the roof of the structure (see Figure 16).

NOTE Each separate structure protected in this alternative way should be equipped with twice the number of down conductors and earth terminations recommended in 16.3.

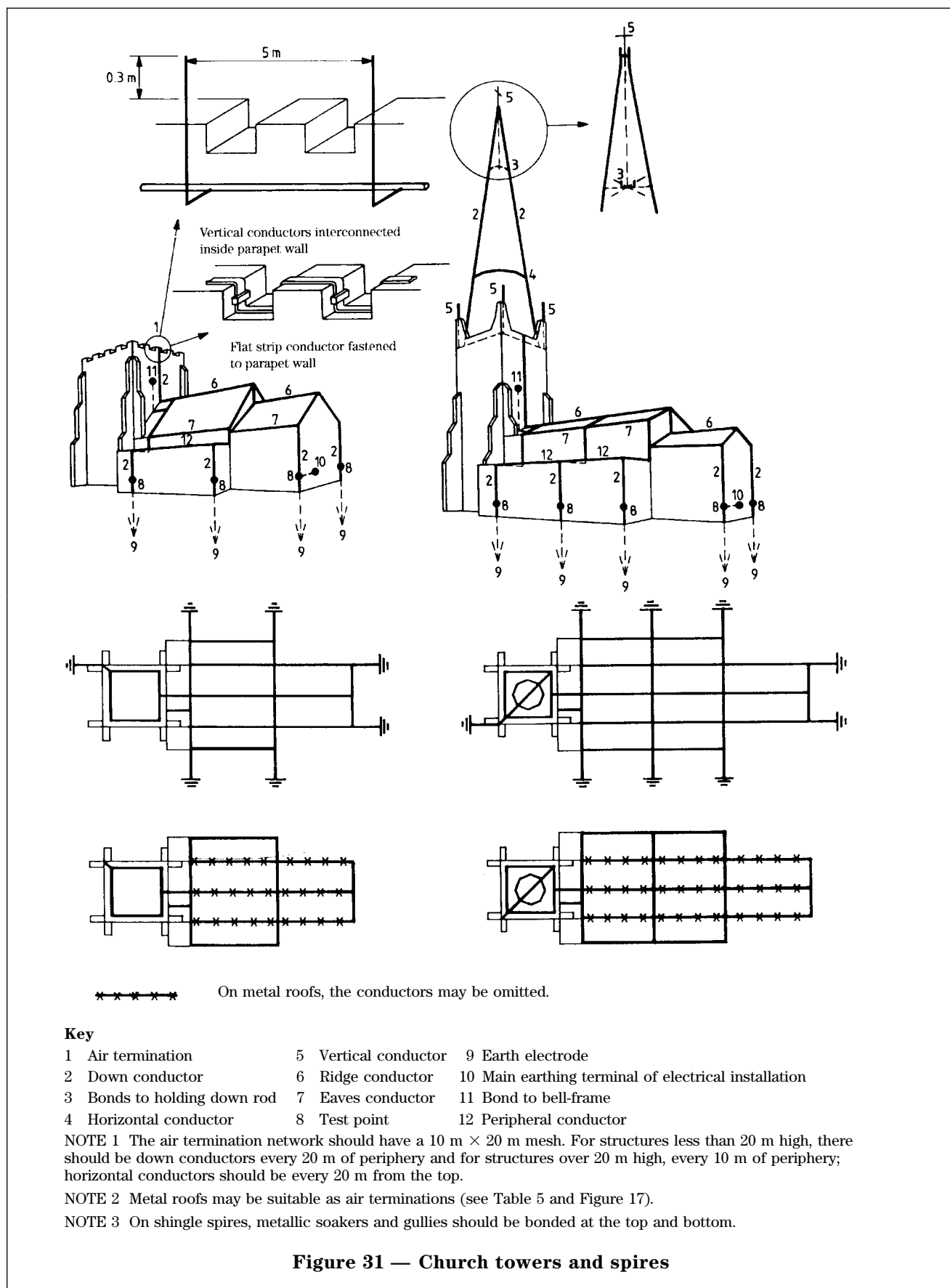

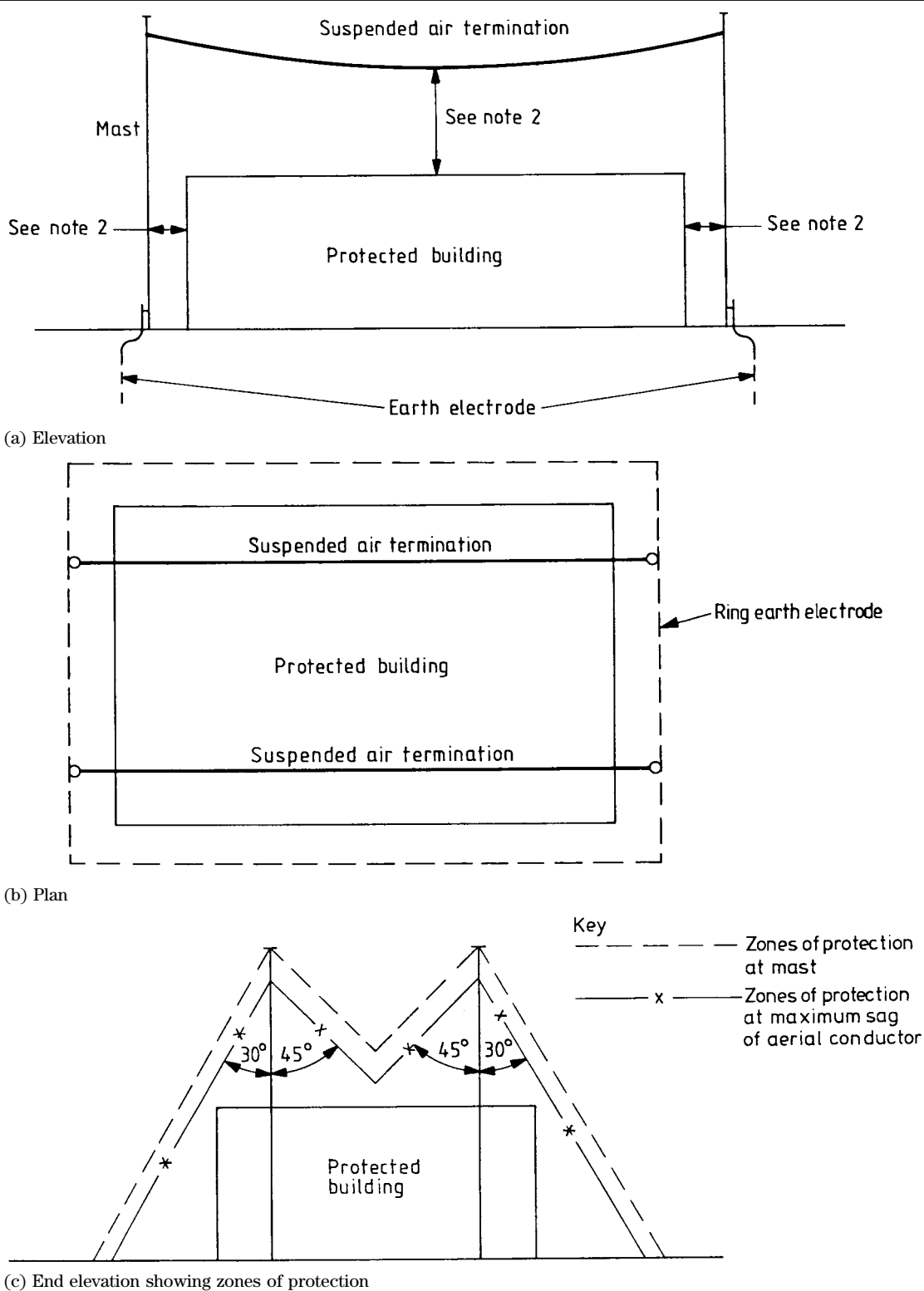

NOTE 1 Where two or more suspended horizontal conductors are employed, a protective angle of 45° may be used in the space bounded by the conductors. Elsewhere the protective angle is limited to 30°.

NOTE 2 To prevent flashover between the mast conductor and the protected building, the minimum clearance distance has to be 2 m or as governed by 19.2, whichever is the greater. The minimum clearance distance has to be maintained under maximum sag conditions i.e. snow and ice on the aerial conductor.

Figure 32 — Air termination with twin suspended horizontal conductors and zone of protection for structures with explosive or highly flammable contents

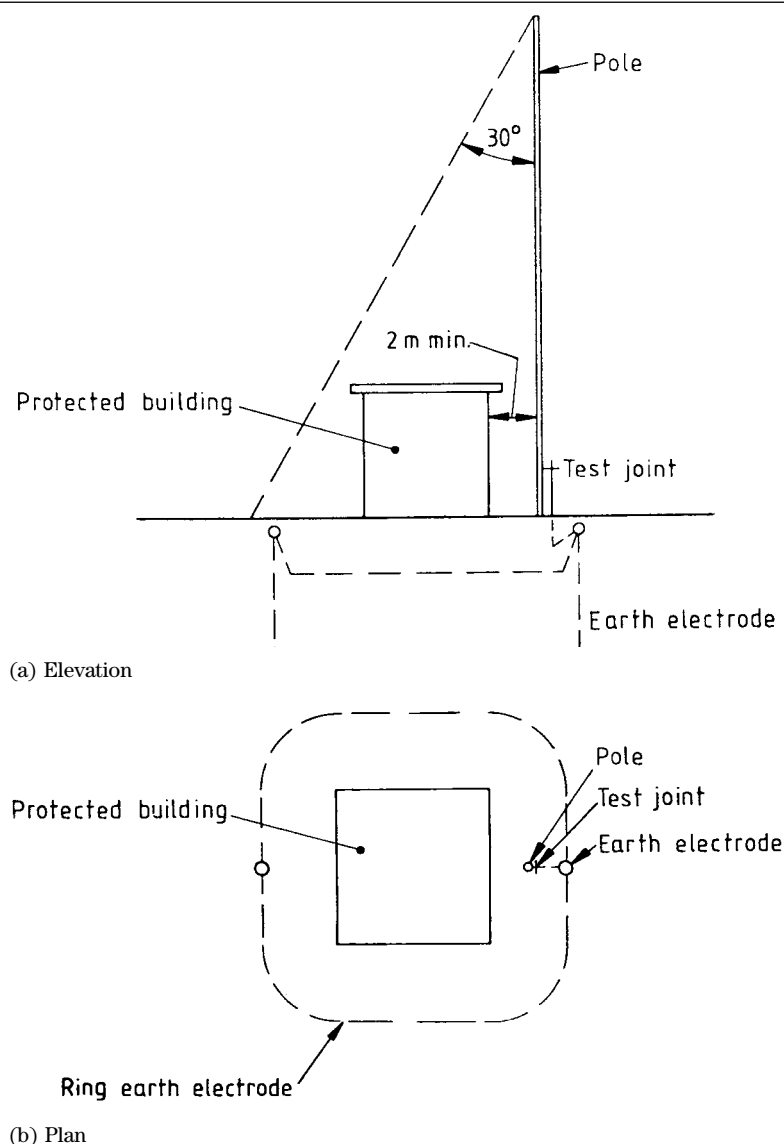

Figure 33 — Vertical air termination for protection of explosive stores

22.2.2 Vertical conductors

A structure or a group of structures of small horizontal dimensions may be protected by one or more vertical lightning conductors. If one lightning conductor is used, the protective angle adopted should not exceed 30° . If two or more lightning conductors are installed, the protective angle to be used may be 45° within the space bounded by the conductors, but it should not exceed 30° outside that space. Examples of this method of protection are shown in Figure 33.

22.2.3 Partially buried or buried structures

22.2.3.1 A structure which is partially buried or mounded should be protected in a similar manner to a structure standing above ground.

22.2.3.2 A structure which is wholly below ground and which is not connected to any service above ground can be protected by an air termination network as in **22.2.1a**), complete with its earth termination network. The impulse breakdown strength of the soil can be taken into account when determining the risk of flashover from the protection system to the structure to be protected, including its services. Where the depth of burying is adequate, the air termination network may be replaced by a network of earthing strips arranged on the surface in accordance with expert advice. Where this method is adopted, the bonding recommendations for metal in, or metal conductors entering the structure, should be ignored (see **22.2.4** to **22.2.6**).

22.2.4 Ring earth electrodes

The earth electrodes of each lightning protection system should be interconnected by a ring earth electrode. This ring earth electrode should preferably be buried to a depth of at least 0.6 m unless other considerations, such as the need for bonding other objects to it or testing, make it desirable to leave it exposed. The ring earth electrodes of neighbouring structures should be interconnected.

22.2.5 Metal on or in the structure

(see also **A.2**)

22.2.5.1 All major metal forming parts of the structure, including continuous metal reinforcement and services, should be bonded together and connected to the lightning protection system. Such connections should be made in at least two places (see Figure 16) and should, wherever possible, be equally spaced around the perimeter of the structure at intervals not exceeding 10 m.

22.2.5.2 Metalwork inside the structure should be bonded to the lightning protection system (see **16.9**).

22.2.5.3 The use of proprietary steel stores of all welded construction for explosives is now quite common. For such stores, adequate lightning protection is afforded by earthing the structure in at least two places.

22.2.6 Electrical conductors entering a structure

22.2.6.1 Electrical conductors entering a structure of this category should be metal-cased. This metal casing should be electrically continuous within the structure; it should be earthed at the point of entry inside the structure on the user's side of the service and bonded directly to the lightning protection system (see Figure 30). The agreement of the operating authority or owner of the cables to the proposed bonding arrangements should be obtained.

22.2.6.2 Where the electrical conductors are connected to an overhead electricity supply line, a 15 m length of buried metal sheathed or armoured cable should be inserted between the overhead line and the point of entry to the structure (see Figure 34). Attention should be given to any regulations and codes of practice which are applicable (see also clause **26**). The precise manner in which this is done is important and should be discussed and agreed with the authorities concerned.

NOTE Overhead supply lines are liable to have large surges induced in them from lightning discharges. Some form of surge suppression is therefore needed where the overhead supply lines join the buried cable. This will allow a large part of the lightning current to be discharged to earth at a safe distance from the structure.

22.2.7 Pipes, rails, etc. entering a structure

Metallic pipes, steel ropes, rails, railway tracks or guides not in continuous electrical contact with the earth which enter a structure of this kind should be bonded to the lightning protection system. They should be earthed at the point of entry outside the structure and at two further points, one about 75 m away and the other a further 75 m away. The earthing of rails should be carried out at the following points:

- a) the point of entry to, or exit from, the structure;
- b) 75 m beyond the point of entry or exit in either direction, i.e. internally if it is an underground structure or externally if above ground;
- c) 150 m beyond the point of entry to, or exit from, the structure in the case of above ground lines;
- d) every 75 m in underground installations.

The same criteria apply to surface lines on which a travelling crane or hoist is being used (see also 19.3.9).

22.2.8 Adit or shaft entrance to structures

For a buried structure or underground excavation to which access is obtained by an adit or shaft, the recommendations in 22.2.7 for extra earthing should be followed for the adit or shaft at intervals not exceeding 75 m, as well as outside the structure.

22.2.9 Fences, retaining walls, etc.

The metal uprights, components and wires of all fences and of retaining walls within 2 m of the structure should be connected in such a way as to provide a continuous metallic connection between them and the lightning protection system (see also clause 24).

22.2.10 Vents

In order to minimize the risk of a direct strike, the vents of any fixed tanks containing flammable gas or liquid, and exhaust vents or stacks from process plants emitting flammable vapours or dusts, should, if at all possible, be located within the zone of protection of the lightning protection system. As this cannot be relied upon totally to prevent ignition, vents should be protected against the propagation of flames by the use of flame arresters, inert gas purges or other suitable means.

22.2.11 Danger from tall components on or near high risk structures

High risk structures should not be equipped with tall components such as spires, flag-masts or radio aerials either on the structure or within 50 m of the structure. The clearance applies also to the planting of new trees but structures near existing trees should be treated in accordance with the recommendations of clause 25.

22.2.12 Safe testing

Testing should be carried out in accordance with the recommendations of clause 32 and the test equipment should be of a type which is intrinsically safe for the particular hazard and complies with the requirements of BS 5501-7.

23 Dwelling houses

The recommendations of this code of practice are applicable to dwelling houses but the provision of protection is unlikely to be necessary in the UK. The protection of buildings with television and radio aerials is further discussed in clause 26. Where protection is provided, the recommended practice for dealing with metallic flue-liners is shown in Figure 35.

24 Fences**24.1 Nature of danger**

If an extended metal fence is struck, the length between the point of strike and the nearest earth termination is raised momentarily to a high potential relative to that of the earth. People or livestock in close proximity to, or in contact with, such fencing at the time of a lightning discharge to the fencing may therefore be exposed to danger. It is desirable therefore to earth the fence via earth electrodes at intervals in order to discharge the lightning as effectively as possible.

Ideally, the continuity of the fence should be broken by gaps along its length filled with insulating sections as this helps to restrict the effect of the lightning strike to the particular section struck. However, where fences are primarily used for security reasons, the inclusion of insulating sections raises other problems. Recommendations for fences for particular purposes are included in 24.2 and 24.3.

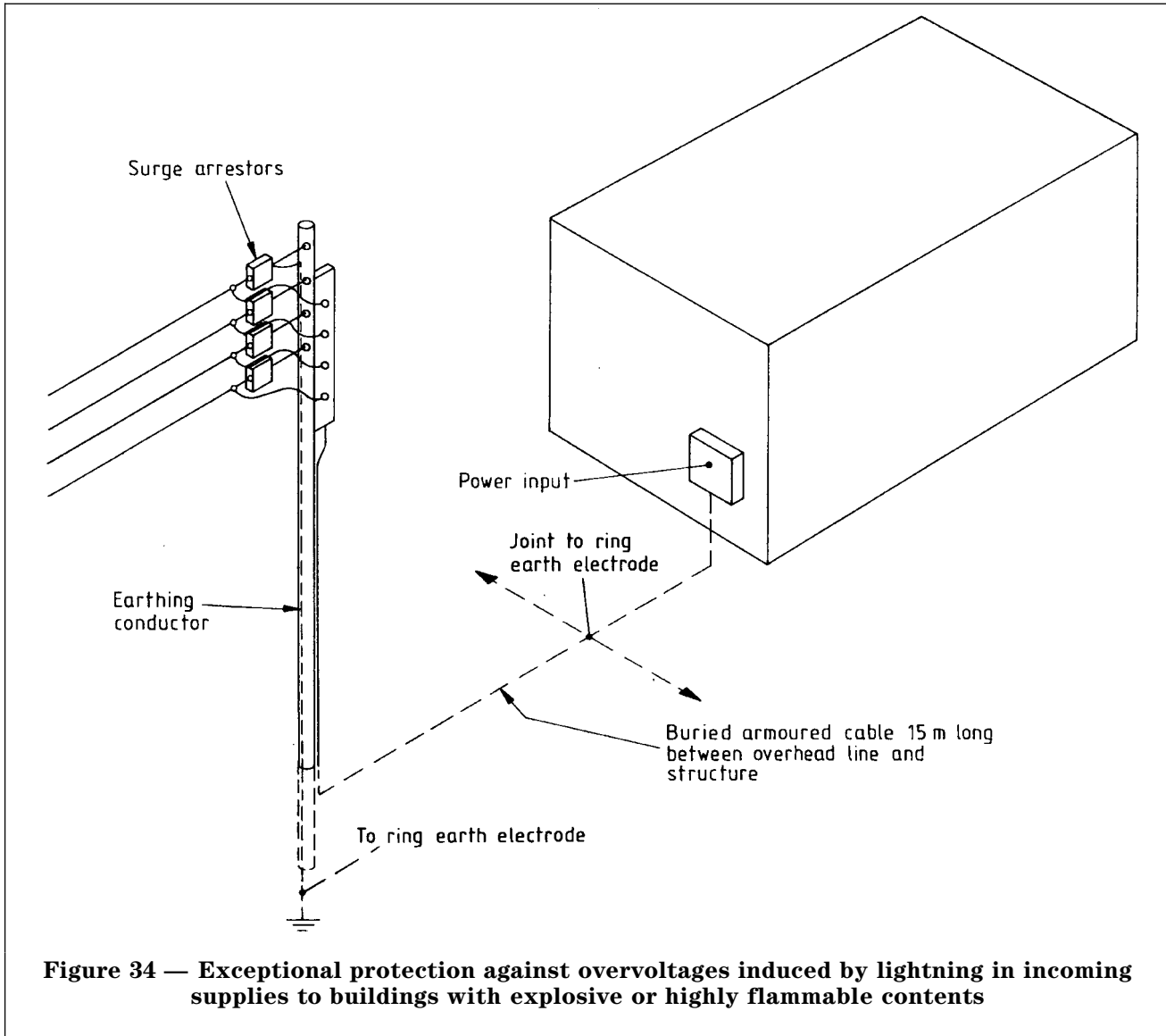

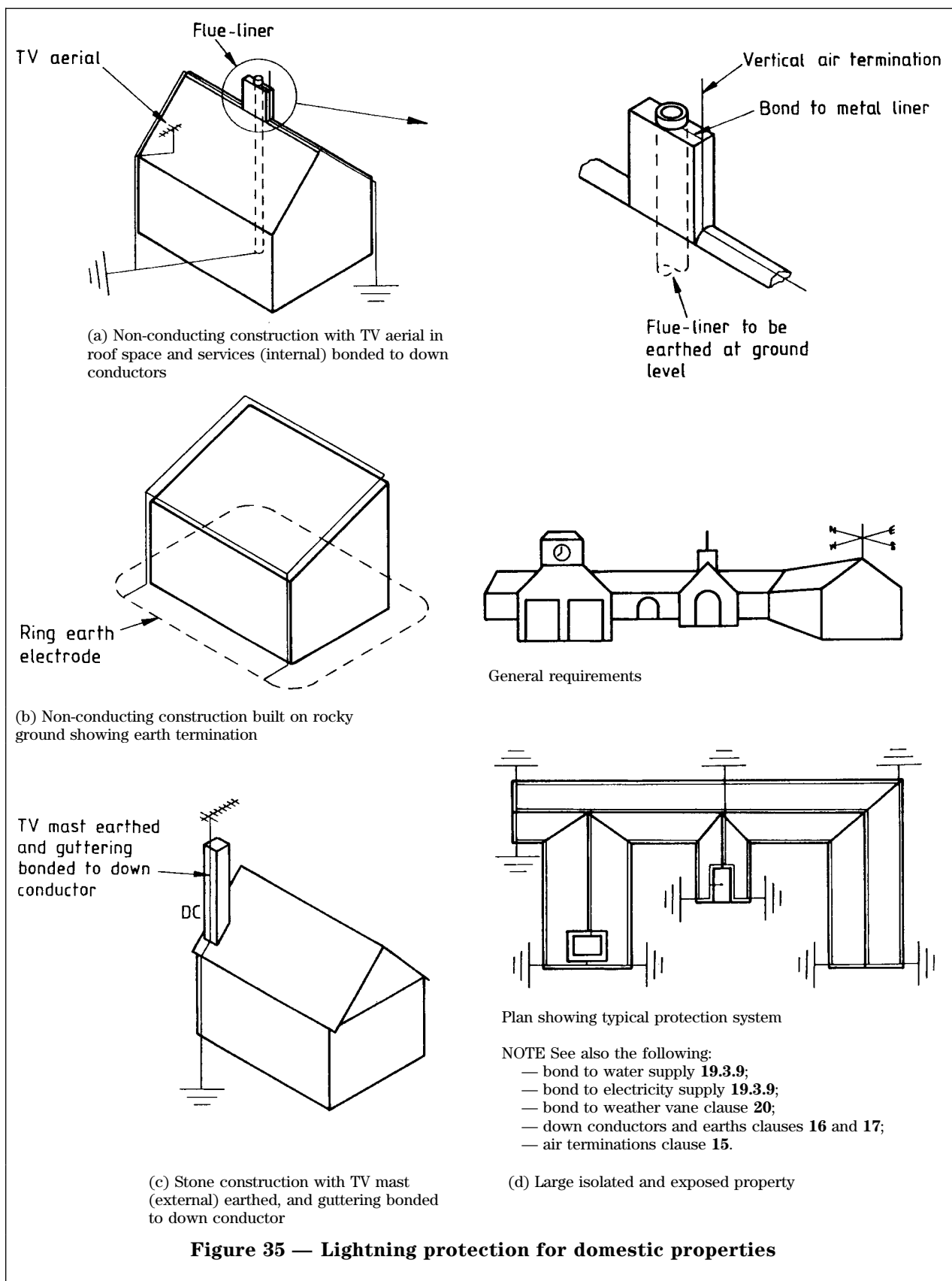

Figure 35 — Lightning protection for domestic properties

24.2 Protection of livestock in fields

24.2.1 General

The loss of livestock due to lightning during thunderstorms is due mainly to herds congregating under trees in open fields or drifting against unearthed wire fences and receiving a discharge sufficient to kill them. The nature of the exposure of livestock in fields is such that it is not possible to eliminate the hazard entirely but if it is desired to minimize the hazard, the precautions in 24.2.2 and 24.2.3 should be taken.

24.2.2 Earthing

Where fences are constructed of metal uprights and continuous electrically-conducting wires, e.g. barbed wire, strained wires or chain link, each continuous wire should be bonded to the metal uprights at intervals. In cases where wooden or concrete posts are used, bonding should be to earth electrodes, e.g. driven rods.

The intervals between bonding should not exceed 150 m where the soil is permanently wet and should be reduced to 75 m in dry soil.

24.2.3 Insulated gaps

The continuity of the metal fence should be broken at intervals not exceeding 300 m by wooden gates or by gaps not less than 600 mm wide closed by sections of non-conducting material.

NOTE The use of chain link fencing covered with a plastics material is not recommended for such closing sections.

The earth termination of the fence at such a gap should be at least 8 m away from either side of the gap.

24.3 Fences surrounding structures containing flammable liquids or gases

24.3.1 Earthing of all-metal fences

Where fences which surround hazardous locations are of the all-metal type, no particular problems arise and they can be earthed as described in 24.2.2 but at intervals not exceeding 75 m.

24.3.2 Earthing of fences coated with plastics material

Much of the fencing in current use is of the plastics-coated close-mesh steel wire type.

The plastics coating provides weather protection and breaking through it in order to earth the metal would increase the risk of corrosion and is not, therefore, recommended.

This type of fencing, however, normally carries a run of barbed wire at high level. It is recommended that this wire should be earthed at intervals not exceeding 75 m in order to act as an air termination for the protection of the fence.

24.3.3 Insulated gaps

Because these fences are primarily for security purposes, insulated gaps may breach security requirements and are therefore not recommended.

Where the security fence separates grazing land from a hazardous or high security area, a balance has to be struck between the attendant risks in each case.

25 Trees and structures near trees

NOTE Additional information on trees and structures near trees is included in A.3.

The protection of trees against the effects of lightning need be considered only where the preservation of the tree is especially desirable because of its historical, botanical, environmental or other similar value. For such cases the following recommendations are made.

- a) A main down conductor should be run from the topmost part of the main stem to the earth termination and should be protected against mechanical damage at ground level.
- b) Large upper branches should be provided with branch conductors bonded to the main conductor.
- c) Conductors so used should be stranded and sheathed. The total cross-sectional area should be not less than 50 mm² for copper and aluminium. No precise sizes are given because this causes problems of availability. The important point is that the conductors should be flexible.
- d) In the fixing of the conductors, allowance should be made for swaying in the wind and the natural growth of the tree.
- e) The recommendations of 16.7 need not be taken into account.
- f) The earth termination should consist of two rods driven into the ground on opposite sides of, and close to, the trunk of the tree. A buried ring earth electrode should encircle the roots of the tree and should also be joined to the rods by two radial conductors. The earth termination and resistance should satisfy the recommendations of clause 17.
- g) Where two or more trees are so close together that their encircling ring earth electrodes would intercept, one ring earth electrode adequately connected to the earth rods should be buried so as to surround the roots of all those trees.
- h) Where an isolated tree stands close to a structure, its presence can be disregarded if its height does not exceed that of the structure. If the tree is taller than the structure, the following clearances between the structure and the tallest part of the tree may be considered as safe:
 - 1) for normal structures, half the height of the structure;
 - 2) for structures for explosive or highly flammable contents, the height of the structure.

If these clearances cannot be ensured, the extent of the risks involved should be considered. To reduce the risks to the minimum, when the tree is to remain, the structure needs to be protected in accordance with the recommendations of this code and the air termination or down conductor should be arranged so as to pass as closely as possible to the nearest part of the tree.

NOTE 1 When a tree is left unprotected, a lightning current discharged into it can be conducted over distances of many tens of metres, along or just under the surface of the ground, in order to find a good conductor, e.g. a water or gas pipe, electricity cable or the lightning protection earth of a building.

NOTE 2 Further advice can be obtained from the Arboricultural Advisory and Information Service.

26 Structures with radio and television aerials

26.1 Indoor aerials in protected structures

Structures protected against lightning in accordance with the recommendations of this code may be equipped with indoor sound radio and television receiver aerials without further precautions, provided the clearance between the aerial system, including the down leads or feeders, and the external lightning protection system accords with the values given in clause 19.

26.2 Outdoor aerials in protected structures

Structures protected against lightning in accordance with the recommendations of this code of practice may be equipped with outdoor radio and television aerials without further precautions, provided that every part of the aerial system, including any supporting metalwork, is within the zone of protection of the lightning protection system. Where these conditions cannot be fulfilled, precautions should be taken to ensure that the lightning current can be discharged to earth without damage to the structure and its occupants as follows.

- a) For an aerial system fitted directly onto a protected structure, the lightning current is discharged by connecting the aerial bracket structure to the lightning protection system at the nearest point accessible below the aerial installation.
- b) For an aerial system fitted on a metallic support structure which projects above the lightning protection system, the lightning current is discharged by connecting the aerial support structure to the lightning protection system at the nearest point accessible below the aerial installation.

26.3 Aerials on unprotected structures

Before installing an aerial on an unprotected structure, the need to provide a protection system should be assessed as described in clause 10.

26.4 Use of earth electrodes of lightning protection system

It is permissible to use the earth electrode of the lightning protection system for the purpose of earthing the aerial system provided this does not conflict with the recommendations of BS 6330.

27 Miscellaneous structures

27.1 Tents and marquees

27.1.1 Large tents

Where large temporary structures of this type are used for such purposes as exhibitions and entertainments involving large numbers of people, consideration should be given to their protection against lightning. In general, such structures are manufactured from non-metallic materials and the simplest form of protection usually consists of one or more horizontal air terminations suspended above the structure and connected solidly to earth. A non-metallic extension of the vertical supports provided for such structures may, if convenient and practicable, be used to support a system of horizontal air terminations but a clearance of not less than 1.5 m should be maintained between the conductor and the fabric of the enclosure. Down conductors should be arranged outside the structure and be connected to earth rods which in turn should be connected to a ring conductor in such a manner as to be inaccessible to the general public. Structures which have metal frameworks should have these efficiently bonded to earth at intervals of not more than 20 m along the perimeter.

27.1.2 Small tents

For small tents no specific recommendations can be given but some of the problems involved are described in A.4 and shown in Figure 36.

27.2 Metal scaffolding and similar structures

Where such structures are of sufficient size to warrant protection and are readily accessible to the general public, particularly where they are erected over and on part of the common highway or are used in the construction of public seating accommodation, they should be efficiently bonded to earth. A simple method of bonding such structures consists of running a strip of metal, other than aluminium, 20 mm × 2.5 mm in cross-section, underneath and in contact with the base plates carrying the vertical members of the scaffolding and earthing it at intervals not exceeding 20 m. With public seating accommodation, only the peripheral members of the structure need to be bonded to earth. Other steel structures, such as those used for pedestrian bridges over main trunk roads, are frequently sited in isolated situations where they may be prone to lightning strikes and should therefore be bonded to earth, particularly at the approach points.

Licensed Copy: Puan Ms. Norhayati, Petroliam Nasional Berhad 4397000, 03 July 2003, Uncontrolled Copy, (c) BSI

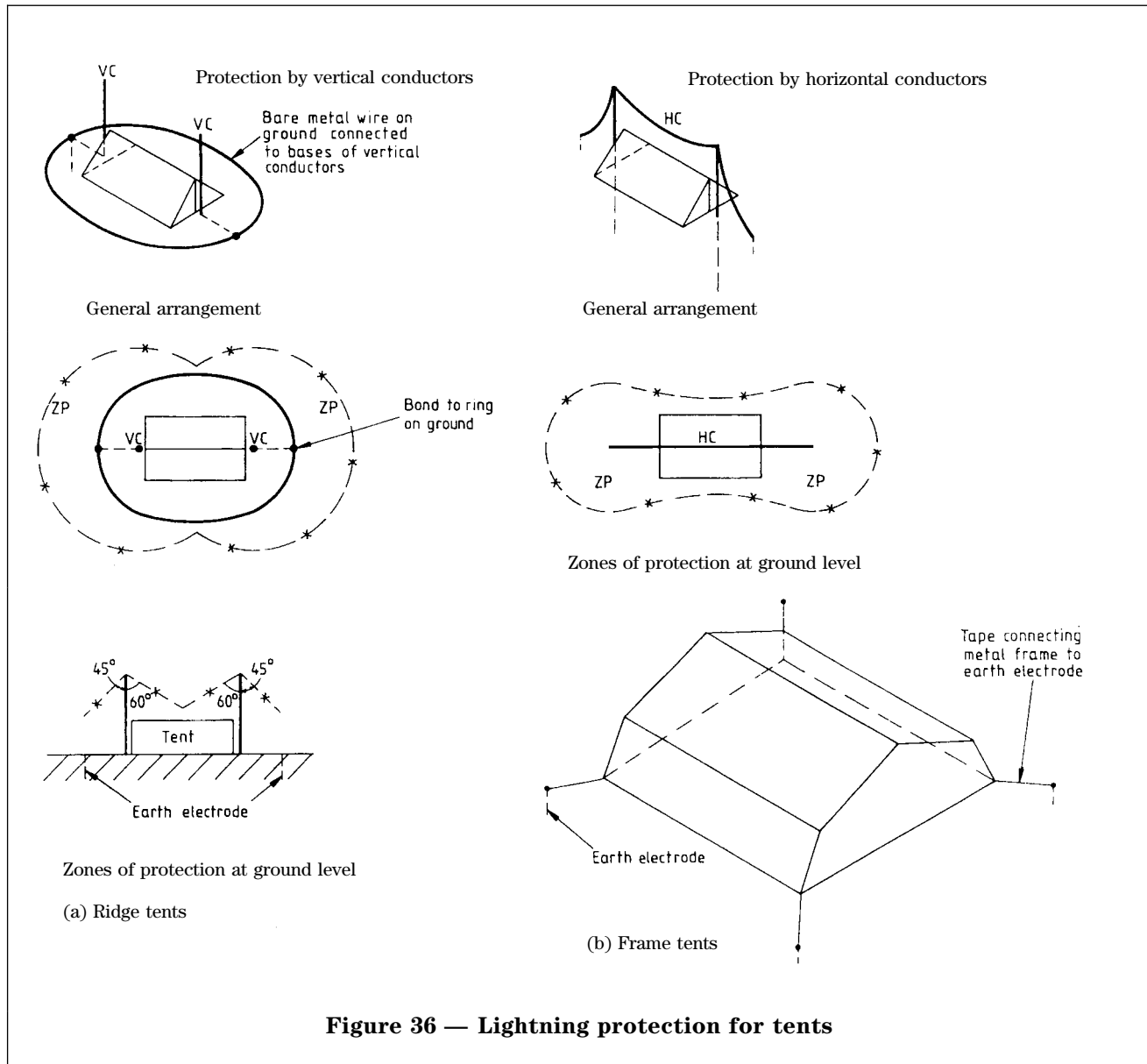

27.3 Tall metal masts, tower cranes and revolving and travelling structures

Masts and their guy wires, floodlighting towers and other similar structures of metallic construction should be earthed in accordance with the recommendations of this code.

Cranes and other tall lifting appliances used in building construction, in shipyards and in port installations should also be bonded to earth. For cranes or revolving structures mounted on rails, efficient earthing of the rails, preferably at more than one point, usually provides adequate lightning protection. In special cases, where there is concern regarding possible damage to bearings by lightning, additional measures may be justified and expert advice should be sought.

27.4 Low cost buildings in areas of high lightning incidence

In some areas, particularly overseas, where lightning incidence is high but where the use of copper or aluminium would be economically unjustifiable or otherwise inadvisable, galvanized mild steel wire may be used for the protection of small farmsteads or similar structures. It should consist of a single strand, not less than 6 mm in diameter, erected to span the roof and ends of the structure and to continue into the ground at a depth of 0.6 m for a distance of 3 m (see Figure 37). Supports may be of timber, arranged to provide a clearance of not less than 0.9 m from the roof. Test joints are not needed, as testing after installation and subsequently is improbable. However, as deterioration is likely to occur first in the buried portions, a short separate length of a material similar to that of the lightning conductor, suitably pointed and galvanized overall,

should be inserted in the ground beside each earth termination to permit periodic withdrawal, visual examination and reinsertion to serve as an indication of the condition of the underground conductor material. Means should be provided to prevent access to the exposed conductor and the ground in the immediate vicinity of the buried metal.

27.5 Sports stadiums

Large sports stadiums in the UK are usually occupied for only a small percentage of the time. Nevertheless, large numbers of people are often in attendance and some measure of protection may be considered necessary.

With the advent of high multi-tier stands, air terminations in the form of horizontal wires could be strung across the stadium from one side to the other. Bonding of all metal parts would need to be performed in accordance with the recommendations of this code of practice.

Another possibility would be to make use of the floodlighting towers, either as essential elements of the lightning protection system or as supports for horizontal wires. In either case provision would need to be made to protect people from danger by direct contact with the towers or against ground voltage stress around their bases. Direct contact with the tower could be prevented by sheathing with a protective insulating material from ground level to a height of about 3 m or by fencing off the tower base and restricting access to it.

Reduction of the ground stress to a level which would not cause harm to people would depend upon the average soil resistivity and the earthing arrangements. Some general comments are given in A.4.2 but it is often desirable to seek specialist advice (see also Figures 20 and 38).

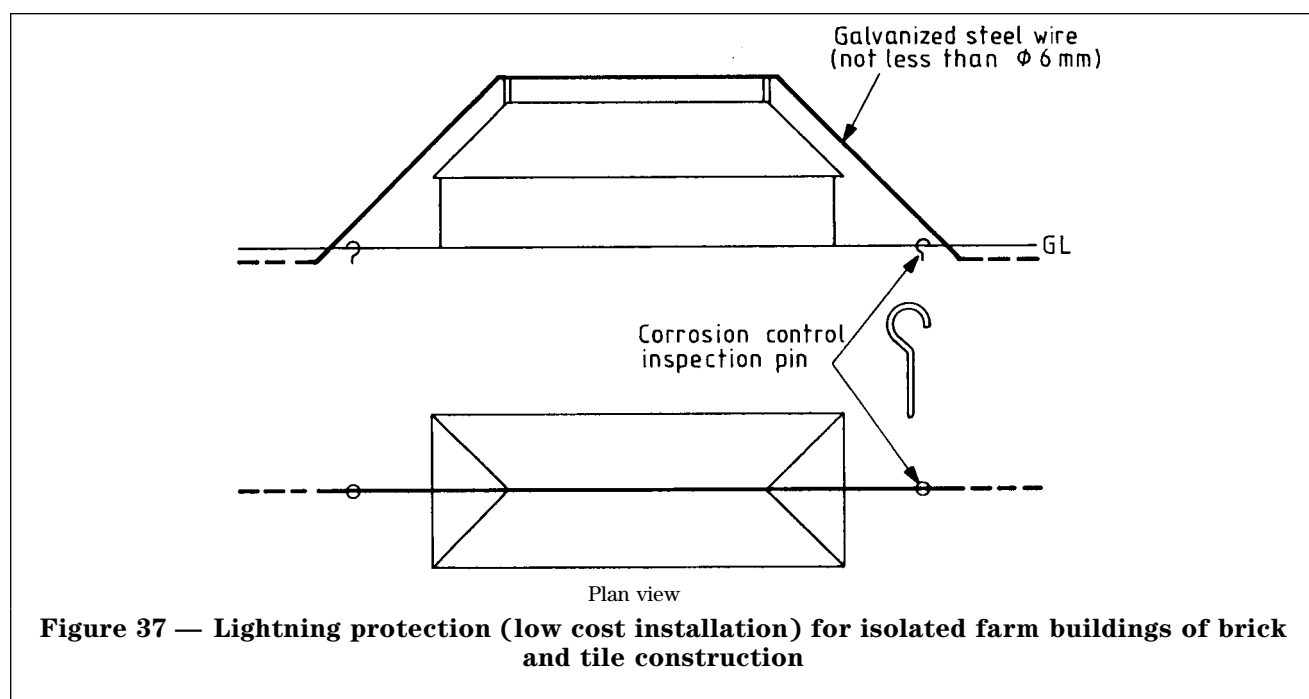
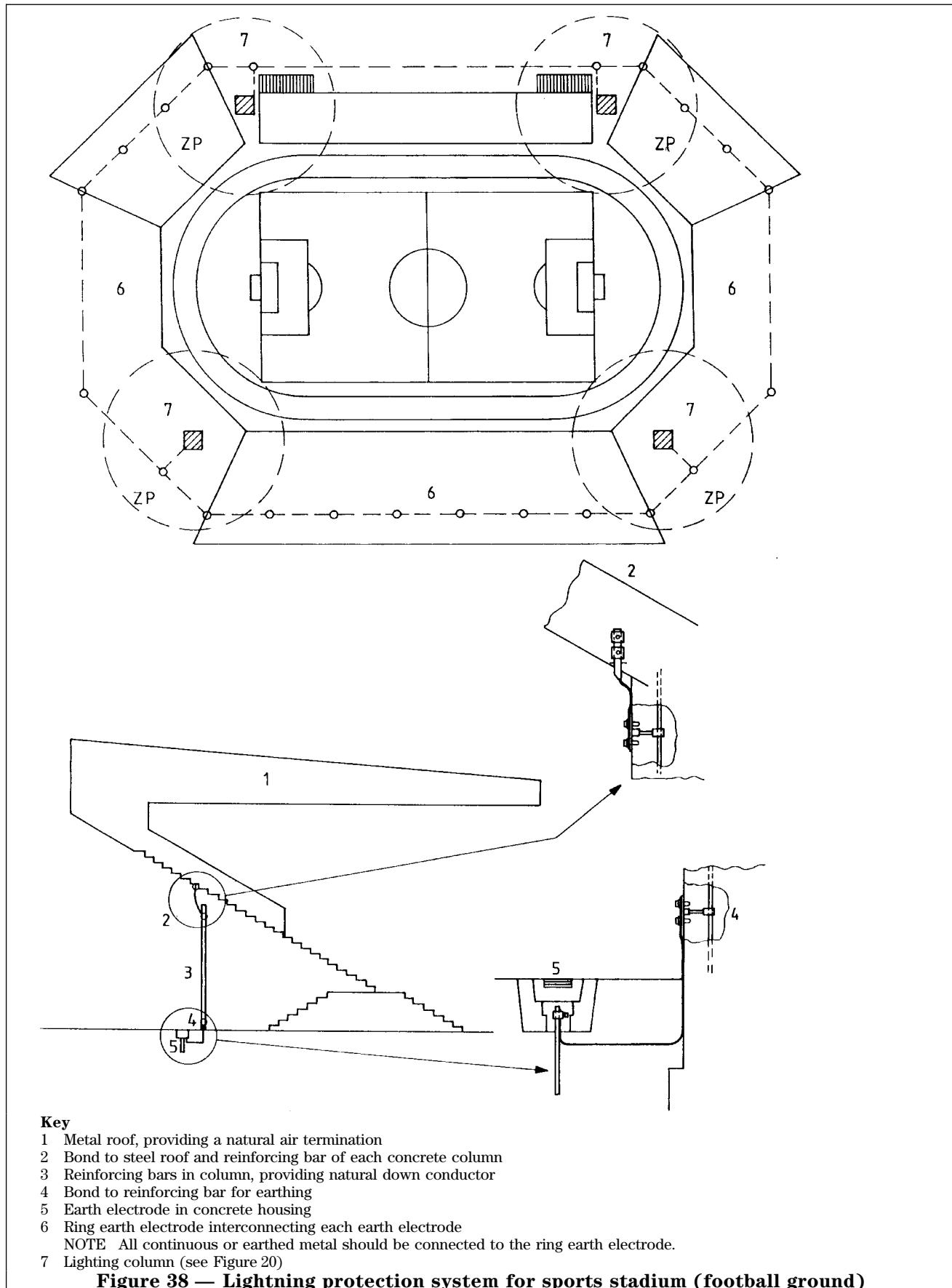

Figure 37 — Lightning protection (low cost installation) for isolated farm buildings of brick and tile construction



27.6 Windmills

27.6.1 General

The few working windmills left in the UK are of great historical and engineering interest and considerable effort is being spent on their preservation. Furthermore, there are many cases where non-working windmills are being restored. Their heritage value coupled with their often exposed position supports their case for protection.

Although windmills differ widely in construction and form, the basic principles for protection are common to all. The recommendations given in 27.6.2 reflect this.

27.6.2 Protection system

Figure 39 shows the basic system comprising the following.

- a) *Air termination.* This protects the sweeps and can take the form of a conductor along the central arms or around the periphery of each arm. These conductors have to be bonded to the metal shaft on which the sweeps are mounted. In cases where there are metal ties joining the outer ends of each sweep, these too, should be bonded to the conductors on each sweep.

In certain cases where the top of the windmill is large and angular, it would be prudent to protect this also. Experience indicates, however, that lightning usually strikes the sweeps and that protection of the windmill body is therefore less important.

- b) *Down conductors.* Two should be used, diametrically opposed in plan.
- c) *Bonding.* All internal and external steelwork should be bonded together. Bearings should be bypassed with slip rings where welding might be caused by high current density during a discharge.

27.7 Bridges

The same principles apply to a bridge as to any other structure of similar construction [see 13.6], clause 16 and Figure 40].

Reinforced concrete and steel constructions should be earthed in accordance with clause 17.

Expansion and other gaps in electrical continuity should be bonded; metal service pipes, rails, handrails, signs, lighting columns and other continuous metal should be connected to the reinforcing bars (see 16.10.4).

It is essential with multiple bridges to ensure electrical continuity between the superposed structures. A lightning strike on the top bridge would cause the lightning current to flow to ground via the lower structures (see clause 19).

Prefabricated parts should be provided with lugs or plates at each end for bonding purposes.

At the foot of stairs on pedestrian bridges, insulating covering should be provided against contact and step voltages.

Simple calculations show that side-flashing is more likely to occur when standing under the edge of a bridge, rather than midway between the supporting pedestals. In this case, the following recommendations apply.

- a) The lighting structure, railings, etc. should be bonded to the reinforcing bars. It is not then necessary to fit a separate, externally mounted down conductor, but if one is provided, it should be bonded to the reinforcing bars at the highest practical level.
- b) In potentially dangerous areas where people are known to group, warning notices should be placed to indicate the dangers of standing near the edge with umbrellas raised.

28 Corrosion

28.1 General

Where corrosion due to atmospheric, chemical, electrolytic or other causes is likely to impair any part of the lightning protection system, suitable precautions should be taken to prevent its occurrence. Guidance may be found in DD 24, PD 6484 and BS 5493.

28.2 Electrolytic corrosion between dissimilar metals

The contact of dissimilar metals, unless the contact surfaces are kept completely dry and protected against the ingress of moisture, is likely to initiate and accelerate corrosion.

Dissimilar metal contacts can exist where a conductor is held by fixing devices or against external metal surfaces. Corrosion can also arise where water passing over one metal comes into contact with another metal. Run-off water from copper, copper alloys and lead can attack aluminium alloys and zinc. The metal of the lightning protection system should be compatible with the metal or metals used externally on any structure over which the system passes or with which it may make contact. Guidance on the choice of metals is given in PD 6484.

28.3 Chemical corrosion of aluminium near Portland cement, mortar mixes, etc.

For a variety of reasons, aluminium is prone to corrosion when in contact with Portland cement and mortar mixes. The following recommendations on installation techniques apply.

- a) Aluminium conductors should always stand off from any surfaces, particularly horizontal ones. This should avoid the conductors lying in water or being held in contact with corrosive materials, such as old mortar, etc. Suitable fixings are shown in Figure 2.
- b) Conductors should not be positioned where they could become covered with debris such as leaves, etc. or buried by soil. This should avoid the "poultice problem" where any electrolyte tends to be held in continuous contact with the conductor.
- c) The design of the cleating system should incorporate some form of drip-ring. This should help to prevent electrolyte that has run off surfaces being able to reach the conductor and run down it.
- d) Where the conditions in a) to c) cannot be satisfied, the conductor should be protected as recommended in clause 7 and consideration given to increasing its cross-sectional area.

28.4 Chemical corrosion of copper

Although copper is highly resistant to many types of chemical attack, lead coating is recommended where it is subject to severe corrosion due to the presence of sulphur compounds. This is particularly the case where the location is inaccessible, e.g. at the tops of chimneys. The coating should be applied over the whole of the area that is likely to be under corrosive attack and should not be removed at joints. Insulating coatings which are not permanent or which are flammable are inadvisable. Fittings should be resistant to the corrosive agencies or be otherwise suitably protected. Joints and bonds may be protected with bitumen or embedded in plastic compound according to the local conditions (see also clause 7 and 16.10.4).

Earth conductors between test points and earth electrodes should be protected against corrosion where they enter the ground for a distance of 0.3 m above and below ground level, PVC sleeving being a suitable means of protection.

29 Structures

Throughout the period of erection of a structure, all large and prominent masses of steelwork, such as steel frameworks, scaffolding and cranes, should be effectively connected to earth. Once work has started on the installation of a lightning protection system, an earth connection should be maintained at all times.

30 Overhead power lines

During the construction of overhead power lines, overhead equipment for railway electrification, etc., the danger to persons can be reduced to a minimum by ensuring that an earthing system is installed and properly connected before any conductors other than earth wires are run out. Once the conductors are run out and insulation installed, they should not be left "floating" whilst they are worked on but should be connected to earth in the same way as they are earthed when maintenance is being carried out after the line is commissioned.

31 Inspection

All lightning protection systems should be visually inspected by a competent person during installation, after completion and after alteration or extension, in order to verify that they conform to the recommendations in this code. Visual inspections should be repeated at fixed intervals, preferably not exceeding 12 months.

In addition, the mechanical condition of all conductors, bonds, joints and earth electrodes (including reference electrodes) should be checked and the observations noted. If, for any reason, such as other site works, it is temporarily not possible to inspect certain parts of the installation, this should also be noted.

During periodic inspection of the lightning protection system, the bonding of any recently added services should be checked to ensure it is in accordance with the recommendations of this code.

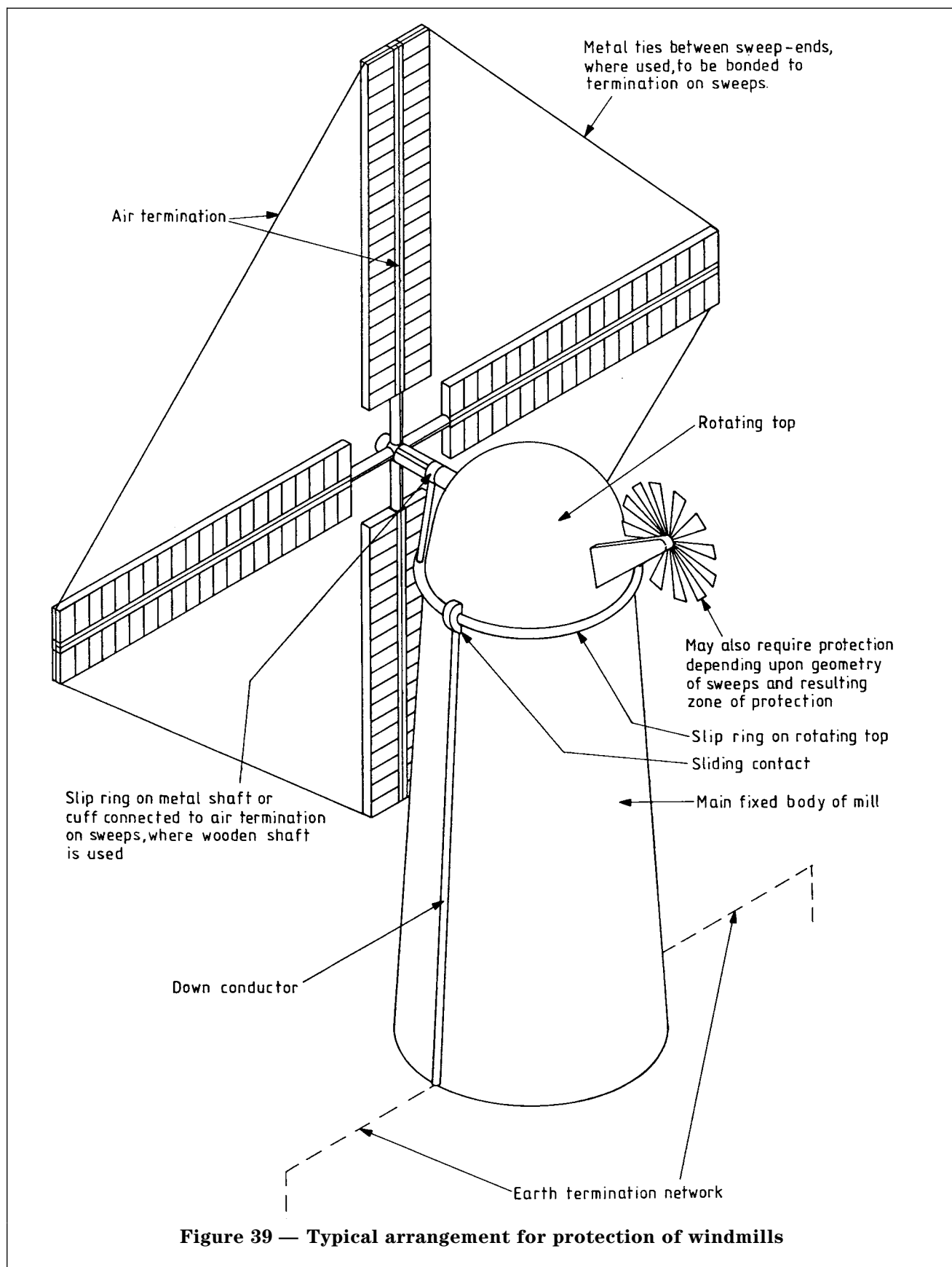

Figure 39 — Typical arrangement for protection of windmills

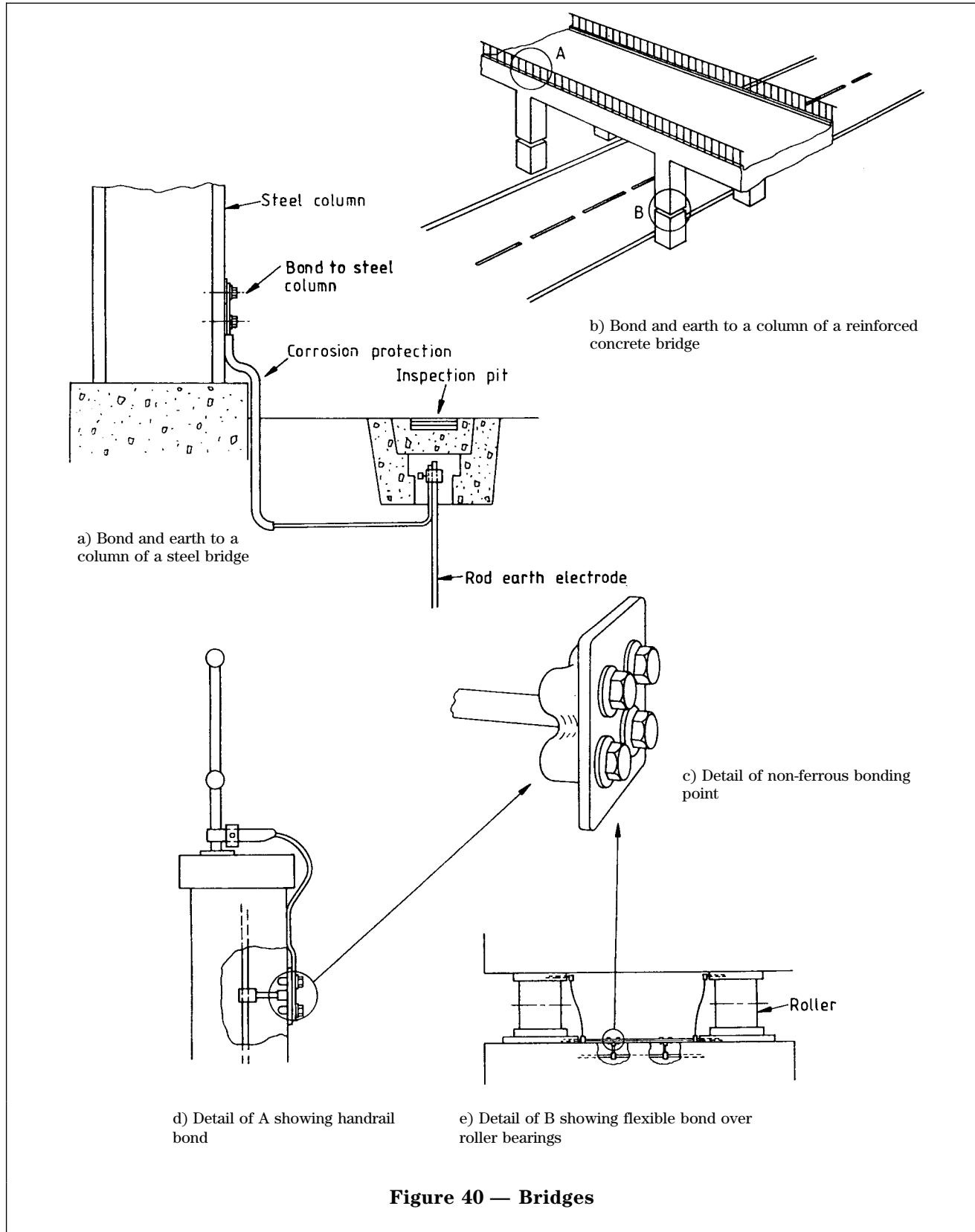

Figure 40 — Bridges

32 Testing

On completion of the installation or of any modification to it, the following isolated and combined measurements and/or checks should be made and the results recorded in a lightning protection system logbook.

- a) The resistance to earth of each local earth electrode and in addition the resistance to earth of the complete earth termination system.

Each local earth electrode should be measured in isolation with the test point between the down conductor and earth electrode in the disconnected position (isolated measurement).

A further measurement should be taken with the test point in the connected position (combined measurement). If there are any significant differences in the measurements in relation to other positions, the reason for such differences should be investigated.

- b) The results of a visual check of all conductors, bonds and joints or their measured electrical continuity.

The recommended method of testing is given in BS 7430.

If the resistance to earth of a lightning protection system exceeds $10\ \Omega$, the value should be reduced, except for structures on rock as described in 17.5. If the resistance is less than $10\ \Omega$ but significantly higher than the previous reading, the cause should be investigated and any necessary remedial action taken.

Tests should be repeated at fixed intervals, preferably not exceeding 12 months.

NOTE 1 It may be advantageous to choose a period slightly shorter than 12 months in order to vary the season in which tests are made.

NOTE 2 It is emphasized that before disconnecting a lightning protection earth, it should be tested to ensure that it is not "live", using a sensitive voltage testing device.

33 Records

The following records should be kept on site or by the person responsible for the upkeep of the installation:

- a) scale drawings showing the nature, dimensions, materials and position of all component parts of the lightning protection system;
- b) the nature of the soil and any special earthing arrangements;
- c) the type and position of the earth electrodes, including reference electrodes;
- d) the test conditions and results obtained (see clause 32);
- e) any alterations, additions or repairs to the system;
- f) the name of the person responsible for the installation or its upkeep.

A label should be attached at the origin of the electrical installation, worded as follows:

"This structure is provided with a lightning protection system that is in accordance with BS 6651 and the bonding to other services and the main equipotential bonding should be maintained accordingly."

34 Maintenance and upkeep

The periodic inspections and tests recommended in clauses 31 and 32 will show what maintenance, if any, is needed. Particular attention should be given to the following:

- a) earthing;
- b) evidence of corrosion or conditions likely to lead to corrosion;
- c) alterations and additions to the structure which may affect the lightning protection system (e.g. changes in the use of a building, the installation of crane tracks or erection of radio and television aerials).

Annex A (informative)

Explanatory notes on some of the recommendations of this code

A.1 Earth termination network earth electrodes [Clauses 17 and 18]

A.1.1 General

Comprehensive information on the subject of earthing is to be found in BS 7430.

A.1.2 Effect of side-flashing and potential difference close to the earth electrode

The risk of side-flashing within the structure to be protected and the risk of a dangerous potential gradient occurring in the ground adjacent to the earth terminations depend on the earth resistance. The risk of side-flashing in some types of structure also depends on other factors in addition to the resistance of the earth termination, as described in 5.2. The potential gradient around the earth termination is a function of the soil resistivity. In Figure 20, a lightning strike is assumed to have occurred to the lightning protection system of a structure. As the lightning current is discharged through the earth electrode, the surrounding soil is raised for the duration of the discharge to a potential with respect to the body of the earth. The resulting potential gradient and the way in which this gradient can be reduced by adding ring earth electrodes to lower the earth resistance are shown in Figure 20.

A potential difference may be lethal to a person if it exceeds a few thousand volts and to an animal if it exceeds a few hundred volts. As this potential difference is a function of the product of the lightning current and the resistance of the earth electrode, the importance of keeping the latter as low as possible, particularly in areas where people or animals are likely to be present, is evident. For practical purposes, a maximum value of 10 Ω is recommended for each earth electrode system where there is danger to people or animals, but any reduction below this would be advantageous.

An alternative method of reducing the potential gradient at the ground surface in the vicinity of earth electrodes is to bury each earth electrode so that its top is at least 1 m deep, and to insulate the connection from the down conductor to the earth termination network with material having a minimum breakdown strength of 500 kV e.g. polyethylene 5 mm thick.

The danger to persons within a structure is effectively reduced by the presence of any floor, other than one of earth or rock.

A.1.3 Use of service pipes as terminations

With the growing use of insulated sections inserted between the main service pipes and the feeds entering structures, reliance cannot be placed on the use of these insulated service pipes as either primary or secondary earthing terminations.

Service pipes should be bonded to the lightning protection system inside the structure such that all connections can be inspected easily.

NOTE Incoming gas pipes should not be used as earthing electrodes (see Figure 30).

A.1.4 Earth termination networks

Examples of the dimensions of earth electrodes in soil of resistivity 100 Ω -m at 10 °C which will generally produce a resistance to earth of approximately 10 Ω for an earth termination network are as follows:

- a) a ring earth electrode in the form of a closed loop not less than 20 m in length installed at least 0.6 m below ground; or
- b) vertical rods or tubes, individually not less than 1.5 m in length and totalling not less than 9 m in length for the whole earth termination network; or
- c) radial conductors totalling not less than 20 m in length installed at least 0.6 m below ground (see 18.3.1); or
- d) reinforced concrete (see A.1.6).

BS 7430 should be consulted for all details.

Deeply driven electrodes are used where, for example, clay lies beneath gravel. Reliance should not be placed on standing water levels. The water, especially in gravel, may be pure and will not necessarily provide a low resistance value for the electrode entering into it.

No appreciable reduction in resistance is achieved by increasing the diameter or surface area of the driven electrode. Larger sizes become more difficult to drive and are more expensive in materials. For example, for electrodes of 1.2 m in length, the relation between diameter and mass is given in Table A.1.

Table A.1 — Relationship between diameter and mass of electrodes

Electrode diameter mm	Approximate mass kg
13	1.4
16	2.3
19	3.2
25	5.4

Table A.1 shows that the mass of a rod 1.2 m in length with a diameter of 25 mm is four times that of a rod of 1.2 m in length with a diameter of 13 mm.

For the same mass of material and in the same kind of soil, one electrode rod 4.8 m in length with a diameter of 13 mm, or four electrodes spaced 1.2 m apart, each 1.2 m in length with diameters of 13 mm, provides a resistance value of about one-third that of one electrode rod 1.2 m in length with a diameter of 25 mm.

A.1.5 Special cases

Special considerations apply at earth terminations for the following:

- a) fences containing metal (see 24.3.1);
- b) trees (see clause 25);
- c) farm buildings (see 27.4);
- d) structures on bare rock (see 17.5).

If a structure on bare rock is protected as recommended in 17.5 and any metal in or on the structure is bonded to the lightning protection system as recommended in 19.3, adequate protection should be provided for people inside the structure. However, people leaving or entering such a structure whilst an overhead thunderstorm is in progress are exposed to the risk arising from the high potential drop likely to occur outside during a discharge to the structure.

If surface soil or a rock vein of high conductivity is available within 30 m to 50 m of the structure, an earthing electrode as described in clause 18 should be provided and this should be connected to the ring conductor. The risk to a person when leaving or entering the structure is thus reduced, although not completely eliminated.

A.1.6 Reinforced concrete foundations used as earth termination network

When reinforced concrete foundations are used as the earth termination network, the following formula may be used to make an approximate calculation of the earth resistance that may be expected:

$$R = \frac{\rho}{\pi \times 1.57 \times \sqrt[3]{V}} \quad (\text{A.1})$$

where

- R is the resistance in ohms (Ω);
- ρ is the soil resistivity in ohm metres ($\Omega\cdot\text{m}$);
- V is the volume of concrete in cubic metres (m^3).

Soil resistivity may be determined using the method given in BS 7430.

Examples of the application of the formula are as follows.

- a) 5 m^3 of reinforced concrete in ground having a soil resistivity of $100 \Omega\cdot\text{m}$ has an earth resistance of approximately 10Ω ;
- b) multiple column foundations of reinforced concrete in ground having a soil resistivity of $100 \Omega\cdot\text{m}$ have the following approximate earth resistances:
 - 1) 0.2 m^3 (equivalent to a hemispherical electrode of 0.9 m diameter) has a resistance of approximately 30Ω , e.g. three column foundations of 0.2 m^3 would have an overall earth resistance of approximately 10Ω ;
 - 2) 0.6 m^3 (equivalent to a hemispherical electrode of 1.4 m diameter) has a resistance of 20Ω , e.g. two column foundations of 0.6 m^3 would have an overall earth resistance of approximately 10Ω .

For the use of piles as earth electrodes, see BS 7430.

A.2 Metal in or on a structure and structures exceeding 20 m in height

[Clauses 19 and 20]

A.2.1 Bonding of extended runs of metal whether connected to earth or not

Any extended metal in or on the structure, not connected to the lightning protection system but in conducting connection with earth, e.g. water pipes, gas pipes, metal sheaths, electrical installations, etc. remains essentially at earth potential during a lightning discharge. Even if an extended metal part is not in contact with earth, a potential difference between it and the lightning protection system is liable to arise although the magnitude of this potential difference will be smaller than if the metal were earthed. If the resulting short-time potential difference between any part of the lightning protection system and any adjacent metal exceeds the electric breakdown strength of the intervening space, be this air, a wall or any other structural material, a side-flash can occur. This can cause physical damage, ignite flammable material or cause electric shocks to people or animals.

A.2.2 Bonding external runs of metal at each end

Such bonding has to be effected at both extremities of any extended metal. The metal may then form part of the discharge path but any risk of physical damage or injury is avoided.

A.2.3 Deciding which metal needs bonding

Difficulties are liable to arise in deciding which metal parts need to be bonded and which can be disregarded in this context. No such difficulties should arise with long continuous installations such as metallic service pipes, ducts, lifts, staircases or long ladders. These can usually be bonded to the lightning protection system without excessive inconvenience or cost. On the other hand, the presence of short isolated pieces of metal such as window frames, which are merely in fortuitous connection with the ground through the rain-covered surface of the structure, can be disregarded.

A structure having reinforcement steelwork or cladding forming a continuous close metal mesh in the form of internal reinforcement or screen approaches the condition in which any internal unbonded metal assumes the same potential as the structure itself. On such a structure, the risk of side-flashing is greatly reduced and the recommendations for bonding can be substantially relaxed.

A.2.4 Dangers of thin metal coverings

If any part of the outer surface of the structure is covered with a thin metal skin, this metal may, by accident or design, form part of the path of the lightning current as it goes to earth. The current may leave the metal, either because the metallic path is not continuous or because its cross-sectional area is inadequate to carry the current without melting. In either case, an arc will be formed which will entail some risk of fire if easily ignitable materials are present. The recommended clearances to avoid the risk of side-flashing are given in 19.2.1.

A.2.5 Inductance of down conductors in relation to height of structure

As the height of a structure increases, the resistive voltage drop in the earth termination network assumes progressively less importance compared with the inductive voltage drop which occurs only along the down conductors.

A.3 Trees and structures near trees

[Clause 25]

Clause 25 gives the circumstances in which it may be advisable to provide protection for trees.

The recommended earth termination network is designed to protect the roots of the tree and to reduce the potential gradient in the event of a lightning discharge to the tree to a safe value within the area bounded by the outer buried strip conductors.

The practice of sheltering under trees during a thunderstorm is dangerous and should be discouraged wherever possible.

When a tree is struck by lightning, a potential gradient develops along its branches, trunk and roots and this may cause a side-flash to an adjacent structure as described in A.2.

The flashover strength of a tree can be taken as 250 kV/m as compared with the breakdown strength of air of 500kV/m. These figures form the basis of the recommendation in 25h) for the minimum safe clearance between a tree and a structure.

If the actual clearance is found to be too small to prevent the occurrence of a side-flash to the structure, the structure should be fitted with lightning protection such that the energy in the side-flash is discharged through the protection system without damage to the structure.

If a tree near a structure is itself fitted with a lightning protection system, the structure may thus be adequately protected. No further lightning protection for the structure is then necessary, provided the conditions recommended in this code of practice with respect to the zone of protection and separation are followed.

A.4 Miscellaneous structures

[Clause 27]

A.4.1 Small tents

For small tents, conformity to the recommendations in 27.1.1 would be expensive. However, in areas of severe thunderstorm activity and in mountainous regions, campers using small tents are strongly advised to adopt certain precautions. These are as follows (see Figure 36).

- a) Protection for small tents can be achieved by the use of one or two telescopic metal poles outside the tent which should be arranged so that the tent lies within the protective angle recommended in 11.2. The foot of each of these metal poles should be connected to an earth spike placed in a direction away from the tent and, wherever possible, driven into a moist piece of ground. In addition, a bare metal wire should be laid on the ground around the tent and connected to the foot of each metal pole.

- b) In the case of metal-framed tents, the metal, if continuous, will act as the lightning conductor. The frame should be connected to two earthing spikes driven as described in a) in opposite directions away from the tent.

- c) In a thunderstorm it is essential, particularly in unprotected tents, to avoid the risk of potential difference across the body. This may be accomplished by lying on a metal-framed cot. If this is not possible, the risk can be reduced by sitting on the ground with the knees drawn up to the chest and by avoiding physical contact with the tent and with other occupants.

A.4.2 Sports stadiums

When a tall lighting column is struck by lightning, the current flows into the ground from the base of the column and a good approximation to the ground stress can be obtained from an assumption that the equipotentials in the ground are hemispherical shells. Hence, with a median current of 30 kA and an average soil resistivity of $10^3 \Omega\cdot\text{m}$, the ground stress will be about 50 kV/m at a distance of 10 m from the column, and will vary with the inverse of the square of the distance (see Figures 20 and 38).

On the assumption that, for humans, the voltage gradient should not exceed 10 kV/m, a distance of 22 m from the column base would be needed in order to reach this level.

Use of a suitable earth electrode in the form of a circular mesh 10 m in diameter could significantly reduce the ground voltage stress in the vicinity of the tower. Additional protection against ground voltage stress could also be obtained by providing an insulated mat of four-ply 1 000 gauge PVC sheets just below the final asphalt layer.

For protection against direct contact with the tower itself, a 5 mm coating of epoxy resin sprayed onto the structure from ground level to a height of at least 3 m is recommended.

Care should be taken in the choice of material used in order to keep its degradation by sunlight to a minimum.

A.5 Structures with complex geometry

[Clause 15.3.4]

The "rolling sphere" method, described in this clause, may be used to identify non-protected parts of tall, complex structures. This method is based on the mechanism of the lightning leader process of attachment to buildings.

A lightning flash is preceded by the step-by-step descent of a downward leader which deposits charge along its route and along the routes of its many branches. As the charged leader progresses, an increasing charge of opposite sign is induced on the earth's surface and the consequential electric field between the two charges intensifies until the field at the earth is high enough for an upward leader to be launched to meet the downward leader and so complete the path for the return stroke.

Lightning therefore terminates on the ground (or on structures) at the place from which the upward connecting leader was launched and, because such leaders are launched at points of greatest electric field intensity and are not constrained to go vertically upwards, they can travel in any direction towards the approaching leader. As an example of this, lightning is known to strike the sides of tall buildings, which should not occur if the 45° cone of protection is applied for all structures.

The positions of greatest field intensity on the ground and on structures are, in general, those nearest to the end of the leader before the last jump. For the purpose of this method, at this instant, points equidistant from the end of the leaders are equally likely to receive a lightning strike, whereas points further away are less likely. Therefore, the surface of a sphere centred on the position of the leader before the last step describes positions to which the leader could jump (see Figure A.1). Since the lightning leader can approach from any position, all possible positions for the leader approach can be simulated by rolling an imaginary sphere, of a radius equal to the last step length, all around and over the building right down to the ground. Where it touches the building a strike could occur and such a portion or surface may need an air termination as described in clause 15. However, if that portion of the building is free from sharp projections, existing closely spaced air terminations or down conductors may be adequate; examples are a flat roof as in Figure 11 or a cylindrical tower as in Figure 5. If there are sharp projections, consideration should be given to the addition of further air terminations.

Simple-shaped tall buildings can be protected as described in Figure 23 but for complex buildings the rolling sphere should be applied. The method is equally applicable to buildings with air terminations on them or ones with suspended catenaries. The method can be used to determine the protected volume of any particular design of lightning protection system.

In general, the smaller the size of the sphere, the greater the protection but the more costly the installation. Sizes from 20 m to 60 m have been recommended in other countries but, for the purpose of this code, it is recommended that calculations should normally be based on a sphere of radius 60 m. However, a sphere of radius 20 m should be used for buildings with explosive or highly flammable contents or which contain sensitive electronic equipment (see C.8.2).

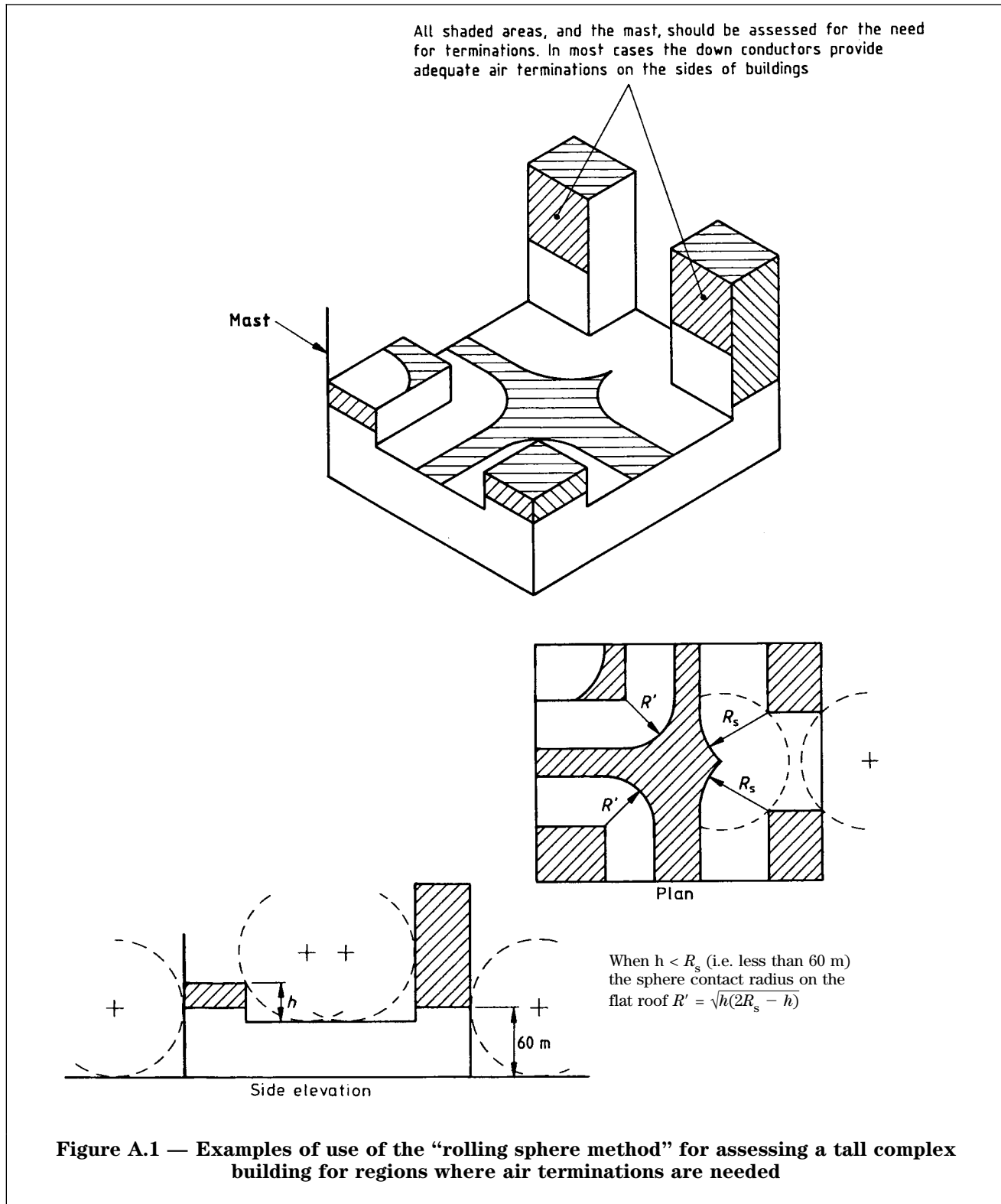

Annex B (informative)

Guidance on the application of BS 6651

NOTE This annex contains a collation of enquiries received by the Technical Committee responsible for BS 6651 and the replies that were given. It is emphasized that the information provided in this annex does not alter the technical content of the standard but provides guidance on its application.

B.1 “Zone of protection” and “rolling sphere” methods of lightning protection

Enquiry

Will the committee please advise whether comparable results can be obtained with the “zone of protection” and the “rolling sphere” methods of designing a lightning protection system?

Reply

The committee considers that the technical basis of the two methods is quite different and comparable results should not necessarily be expected. The technical factors involved in the design of the lightning protection systems are more fully taken into account by the “rolling sphere” method but there has been much satisfactory practical experience with the simple “zone of protection” method which is easier to apply.

B.2 Damage to metal cladding caused by direct arc-connected strike

[Note to Table 5]

Enquiry

Will the committee please advise what mechanical damage can occur to metal cladding applied to structures as a result of a lightning strike and can the effects be calculated?

Reply

The committee considers that it is possible for puncture of the metal cladding to occur but this is normally avoided by using a sheet thickness of at least 2 mm.

Although mathematical formulae exist to determine the forces between the lightning conductor and other current-carrying conductors, these are very complex and it would be difficult to determine the distribution of current in the cladding and supporting structure. Adequate fixing to provide mechanical stability under conditions likely to be encountered in service should be sufficient to withstand the forces during a lightning strike.

B.3 Tall brick-built chimneys

[Figure 5]

Enquiry

Will the committee please advise whether the change in the radius of the rolling sphere from 20 m to 60 m alters the recommendations for the spacing of ring conductors for brick-built chimneys above 20 m in height?

Reply

The committee considers that the recommendations are unaltered. Ring conductors need to have 20 m spacing in order to assist in dispersing the lightning current.

B.4 Lightning protection for flat roofs

[Clause 15.2 and Figure 10]

Enquiry

Will the committee please advise why a mesh is recommended for the air termination on a flat roof when protection is afforded by parallel conductors 10 m apart?

Reply

The committee considers that a mesh ensures that the lightning current at the point of strike is quickly dispersed throughout the air terminations to all down conductors thus reducing mechanical and thermal stress and minimizing the risk of side-flashing.

B.5 Air terminations and tiled roofs

[Clause 15.3.5]

Enquiry

Will the committee please advise the conditions under which air terminations may be installed below tiled roofs?

Reply

The committee considers that air terminations should be installed over the tiles of tiled roofs for maximum effectiveness of the lightning protection system. However, if architectural considerations outweigh the need for maximum protection, air terminations may be installed below the tiles but as close to them as possible. This will result in an indeterminate reduction in overall effectiveness which is considered to be not very significant other than for the possibility of localized damage to the tiles in the event of a lightning strike.

If architectural considerations permit, the effectiveness of an installation beneath the tiles can be improved and the risk of damage to tiles reduced by the addition of short vertical finials spaced not more than 10 m apart, which are connected to the air termination and emerge through the ridge and eaves tiles. As an alternative, where short vertical finials are unacceptable, exposed metal plates may be used.

It is normally only practicable to install air terminations under tiles during construction or re-construction of the roof.

Because of the diversity of the architectural details of tiled roofs, it is not possible to provide details of any particular methods of installation of such air terminations and it is recommended that the actual method employed be the subject of agreement between the lightning protection installer and the architect or builder. The method used should not impair the roof's

resistance to penetration of water and should provide suitable means for installing ridge conductors, interconnecting conductors from the ridge to eaves conductors, the eaves conductors and any necessary bonding conductors.

Any metal components in the structure, such as metal gutters, may be incorporated into the system in place of the conductors referred to above.

Although the installation of air terminations below tiles may result in some damage to the tiles in the event of a lightning strike to the air termination, the protection afforded to the remainder of the structure is expected to be normal.

B.6 Design of a lightning protection system for a structure having different side elevation heights effectively above and below 20 m

[Clause 16.3]

Enquiry

Where a structure is built on a sloping site and the effective height of one side of the structure is less than 20 m whilst the other side is in excess of 20 m, will the committee please advise whether each elevation of the structure should be judged on its individual height or should a judgement be made on the whole of the structure?

Reply

The committee considers that the criteria for the design of the lightning protection system should be applied to each individual elevation.

B.7 Use of reinforcement in concrete structures

[Clauses 16.6 and A.1.6]

Enquiry

Will the committee please advise whether a reinforced concrete pile can be used as a down conductor and, without any additional electrode, as an earth termination?

Reply

The committee considers that provided the recommendations in 16.6.2 are followed, the use of reinforced concrete piles as down conductors and earth terminations is acceptable. The bonding of down conductors recommended by BS 6651 can be regarded as satisfying also the recommendations in 12.2 and 12.3 of BS 7430:1998 to which A.1.6 refers. In a lightning protection system, there is, of course, no continuous current flow and 5.3 indicates the limited thermal effects of a lightning discharge.

B.8 Lightning protection system for a reinforced concrete chimney

[Clause 16.6 and Figure 5]

Enquiry

Will the committee please advise whether for reinforced concrete chimneys, the provision of separate down conductors, and for chimneys over 20 m high, horizontal conductors are necessary?

Reply

The committee considers that the note below Figure 5, read in conjunction with 16.6, indicates that it is not essential for reinforced concrete chimneys to be provided with down conductors or for chimneys over 20 m high in applicable cases to be provided with horizontal conductors. The provision of additional protection is unlikely to be detrimental but its cost and maintenance need to be seriously considered as any gain in the level of protection is likely to be marginal.

B.9 Down conductors in internal ducts

[Clause 16.7]

Enquiry

Will the committee please advise whether a wall cavity can be used as an internal duct where an external route is not available? Would the recommended fixing centres in Table 1 then apply?

Reply

The committee considers that in principle a wall cavity conforming to 16.7 can be considered as an internal duct. However, it will then need to be recognized that the desirable access to the interior of the duct is unlikely to be available, that bridging of the cavity is a possibility, the corrosion of the down conductors could present a serious problem (see clause 28), that bonding to the lightning protection system will be made more difficult, and that access to the test joint should preferably be provided from outside of the building.

The recommendations for conductor fixing centres in Table 1 apply also when the conductor is in an internal duct.

B.10 Recommendations for lift installations

[Clauses 16.10.2 and 19.3.10]

Enquiry

Will the committee please advise how bonding of lift shaft steelwork to the lightning protection system is to be achieved in view of the waterproofing of the tanking in lift shaft pits?

Reply

The committee recommends bonding to minimize voltage differences between lift shaft steelwork and the lightning protection system and considers that this can be effected by:

- a) passing the bonding conductor through the lift pit tanking by means of a seal of the type shown in Figure 24; or
- b) bonding to the building steelwork which itself is bonded to the lightning protection system provided that the joints in the steelwork are of negligible impedance; or
- c) making the bonding connection above the level of the tanked lift pit and thence to the lightning protection system or other steelwork which is itself bonded to the lightning protection system.

B.11 Earthing of steel framed buildings

[Clause 17.1]

Enquiry

Where a steel framed building is used as the down conductor, will the committee please advise whether it is possible to use the foundations as an earth with electrodes installed and connected to steel columns and whether the number of electrodes is determined as if conventional down conductors were being installed?

Where a steel framed building is connected to reinforced piles which are used as the earthing system, the standard recommends that each vertical column is connected to the pile below. Will the committee please advise whether it is possible to connect to the number of piles that correspond with the number of earth electrodes?

Reply

The committee considers that the purpose of 17.1 is to achieve a low resistance between the lower end of the steel frame and earth. The reinforced piles at the outside of the building are normally the most effective for earthing purposes due to the better ground conditions. Whether one or more of the piles is to be connected to each column of the steel frame will depend on the recommendations for resistance to earth.

B.12 Bonding of external metal clad structures

[Clauses 19.3.2 and A.2.3]

Enquiry

Many modern structures have external cladding usually in the form of large infill panels which are insulated by rubber seals from the support frame which itself is interconnected and electrically continuous. Will the committee please advise whether it is sufficient to bond the main and support framework or do each of the individual panels need to be bonded also?

Reply

The committee considers that it is always advisable to ensure that external metal panels are bonded. Generally because of the nature of the construction and fixing of these panels it is considered that a continuous path to earth exists (see 17.1). However where the integrity of the conducting path is questionable supplementary bonding should always be provided.

B.13 Bonding of the lightning conductor to the main earthing terminal

[Clause 19.3.9 and Figure 30]

Enquiry

Will the committee please advise whether there is any safety hazard in bonding the lightning conductor to the main earthing terminal of the protected installations as shown in Figure 30?

Reply

The committee considers that bonding of the main earthing terminal to the lightning conductor should not increase the danger to an electrical installation within the protected structure but should actually reduce the danger to the structure and its contents, including persons, during the discharge of a direct lightning strike to the protected structure.

A lightning protection system conforming to BS 6651 should have down conductors spaced at 20 m intervals around the perimeter of the protected structure and electrical main intakes will generally be within 15 m of a down conductor. The bonding conductor should be sized as an installation earthing conductor associated with the main electrical supply but need not be greater than the down conductor to which it is connected (see 16.10.2).

B.14 Bonding of the lightning conductor to service pipes

[Clause 19.3.9 and Figure 30]

Enquiry

Will the committee please advise whether there is any safety hazard in bonding the lightning conductor to all other service pipes, especially the gas service pipe, as shown in Figure 30?

Reply

The committee points out that bonding of the lightning conductor to the gas service pipe, as shown in Figure 30, is a requirement of BS 7671. The fitting of an insulator, as illustrated in Figure 30, is to isolate the cathodic protection on the gas service pipe. The insulator is not considered to be vulnerable to breakdown if the building structure is struck by lightning. However, if there is any reason to doubt its integrity then a surge diverter should be placed across the flange.

B.15 Utilizing steelwork beneath combustible roofing materials as an air termination

[Clause 15.2]

Enquiry

Will the committee please advise whether on flat roofs it is possible to use the steelwork beneath combustible roofing materials as an air termination? Such roofing materials could consist of roofing felt, insulating board and/or thermal insulation (polystyrene etc.).

Reply

The committee considers that the existence of combustible materials between the steelwork and the roof surface constitutes a fire risk in the event of a lightning strike to the steelwork. Therefore, it is recommended that an independent air termination network mesh is installed above the roof in accordance with 15.2 and that the mesh conductors are positioned, where practicable, vertically above the steelwork members. The mesh and steelwork should be bonded at roof level and ground level.

Annex C (informative)

General advice on protection against lightning of electronic equipment within or on structures

NOTE It is emphasized that this annex is included for information only, and that compliance with annex C is not necessary for compliance with BS 6651 as a whole unless invoked in a contract.

C.1 General

This annex gives general advice on the assessment of the risk of damage to or maloperation of electronic equipment within or on structures due to lightning, and on the design of systems for the protection against lightning of such equipment. Throughout the annex the term “electronic equipment” has the meaning given in 3.1.17. The implementation of the advice given may also provide some level of protection against transients from other origins (e.g. switching transients).

A conventional lightning protection system is designed and installed only to protect the fabric of a structure. However, with the increasing reliance of industry and commerce on sensitive electronic equipment, there is now a need to give an insight into the problems and advice on methods of protecting such equipment and associated data (software, etc.) from the effects of a lightning strike.

The complexities of the phenomena of lightning striking buildings, the lightning current flow through buildings and the coupling mechanisms giving rise to transients which cause damage to equipment and corruption of data are outlined. The risk of occurrence of transient disturbances from lightning is covered in C.4 but there are many factors which can dictate the need for such protection, for example the need to:

- a) minimize fire risks and electric shock hazards;
- b) prevent extended stoppages in industry and commerce with the inherent financial implications;
- c) prevent health and safety hazards resulting from plant instability after loss of control;
- d) safeguard essential services such as fire alarms, communications and building management systems;
- e) prevent costly repair programmes to computer and instrumentation systems.

The advice given in this annex is of a general nature and its application to a specific protection system should take into account the particular conditions pertaining to that system. In cases of difficulty, specialist advice should be sought.

It is emphasized that even where protection is provided it can never be completely effective in eliminating the risk of damage to equipment or corruption of data.

Figure C.1 illustrates how lightning current may enter industrial plant and associated control systems following a lightning strike to buildings, control rooms or the surrounding ground.

C.2 Application of this annex

When applying the advice in this annex, the following procedure should be adopted.

- a) Decide whether there is a need to protect the structure against lightning (see clause 10).
- b) If the answer to a) is yes, consider the design specification that is needed to protect the structure, and then proceed to c). If the answer to a) is no, then proceed directly to c).
- c) Decide whether there is a need to protect the electrical and electronic installations within or on the structure against lightning. (See C.4 and C.5)
- d) If the answer to c) is yes, then consult C.3, C.7 and C.13. If the answer is no, then no further action is required.

NOTE 1 Useful background information relating to various aspects of lightning protection is given in C.8 and C.9.

NOTE 2 Sample calculations are given in C.6, C.10, C.11 and C.12.

C.3 Basic considerations of electronic system lightning protection

C.3.1 Exposure levels

Before dealing with detailed design for protection of electronic equipment, the basic protection provided by the building should be considered. The information given in C.4 and C.5 assists in making the decision as to whether protection of electronic equipment is required.

C.3.2 Protection provided by the building

When considering the protection of electronic equipment in a building and the need for such protection, it is necessary to take into account whether or not the structure of that building is already, or will be, equipped with a lightning protection system in accordance with the recommendations of this code of practice. Furthermore, the risk analysis (in C.4) of the need to provide protection for electronic equipment will often give a different result from that obtained by the risk analysis in clause 10. However, it is worth bearing in mind that many of the aspects of the protection of building structures and electronic equipment in buildings may already be necessary for some other reason, such as earthing and bonding to comply with BS 7671.

The type of structure which affords ideal lightning protection is a building with metal cladding on all walls and the roof providing a “screened room” environment for the electronic equipment. If all the cladding and roofing is satisfactorily bonded together, it enables the lightning current from a strike anywhere on the structure to flow as a “sheet of current” all over the surface and down to the earth terminations. Many steel framed or reinforced concrete buildings with metal cladding approximate to this ideal and attention need only be paid to the prevention of transients brought in on the supply mains or other services. (See Figure C.2).

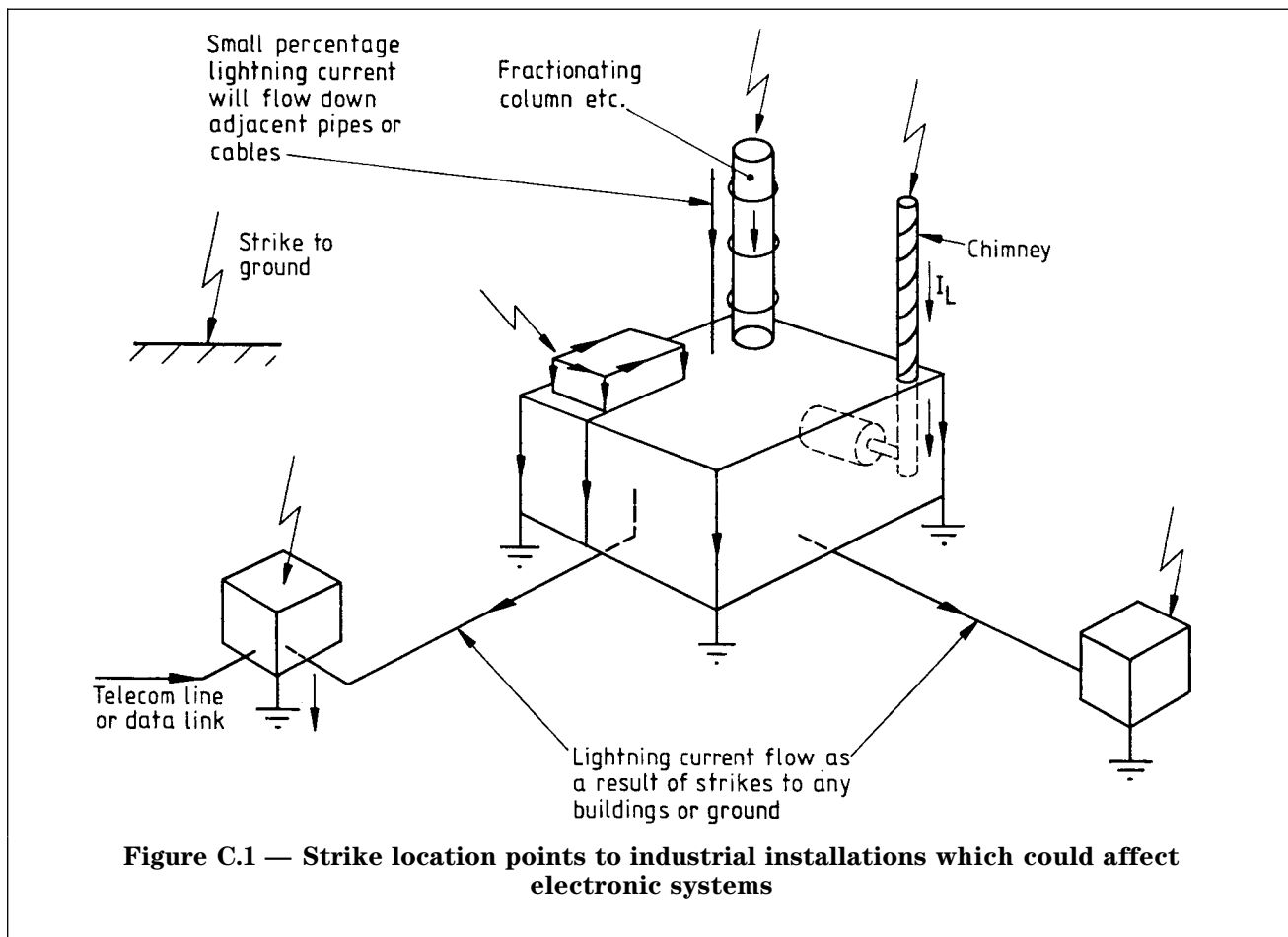

Hence care should be taken to obtain a low impedance bond to the lightning earth termination system from the metal armouring of the mains feeders, gas, water and other services. The method of power supply entry as shown in Figure 30 is recommended, with surge suppressors being provided if so indicated by the risk assessment. With such “screened room” buildings, electronic installations totally within the building are very well protected.

Where buildings are constructed from reinforced concrete or are steel framed with no metal cladding, lightning currents can flow in internal stanchions and advice is given in C.7.2 regarding precautions for computer location and wiring layout.

If the construction materials of a building are substantially free of metal, it may be necessary to treat the building as a “high risk” structure (see clause 22) and give enhanced conventional building lightning protection. (See C.7.1).

In general, surge suppression devices should be fitted as close to the point of entry/exit to the structure as practical.

C.3.3 Current routes in buildings

Current flow in a “screened room” building has been referred to in C.3.2 where it was noted that current principally flows as a “sheet of current” distributed all over the surfaces of roof and walls and down to the earth termination. Minor resistance variations in different parts of the surface have little effect because current flow paths are determined by inductance and not by resistance, owing to the fast impulsive nature of the lightning return stroke and restrikes.

A similar tendency for current to flow on external conductors occurs in steel framed or reinforced concrete structures, having the configurations shown in Figures C.3 and C.4, where the example of current confined to 15 discrete paths is given. It should be noted that the internal stanchions labelled A, B and C in Figure C.4 carry a very small percentage of the current and so give minimal magnetic fields inside. Thus the lightning protection afforded to electronic equipment within a building is considerably improved by having many down conductors, preferably around the periphery of the building. The more down conductors that are available to carry current on the periphery, the weaker the magnetic fields inside and the less the likelihood of transient interference into electronic equipment. It can thus be seen that a single down conductor installed in a building is unacceptable from both the lightning transient injection and side-flashing aspects.

C.3.4 Effect on the magnitude of lightning transients with different system configurations

The ideal type of arrangement for buildings and electronic systems within them which minimizes the risk of lightning discharge currents causing damage or upset to the systems, is shown in Figure C.2a).

In such circumstances, measures are taken to protect against lightning-induced, transient voltages in the mains power supplies to the buildings. This is the arrangement described in C.3.2 where the building structures are well protected against lightning.

Electronic systems in non-metallic buildings without external lightning protection are most at risk and careful consideration of the method of protection of such buildings and their contents is needed. An explanation of some of the risks is given in the following paragraphs of this subclause and guidance on protection against them is given in C.7.1 and C.7.2.

An example of a type of situation where there can be considerable risk is a building which contains electronic equipment and which may have associated equipment such as radio or radar aerials, meteorological apparatus or, in the case of a process plant, sensors mounted externally. This associated equipment may be mounted on the sides or top of an adjacent mast, radio tower, process vessel or conventional building as illustrated in Figure C.2b). The roof or mast equipment is outside the protected environment of the building with its lightning protection system, but cables leading from the equipment into the protected building can introduce severe transient voltages into the electronic equipment in the building if the roof or mast equipment is struck by lightning, no matter how good the lightning protection on the building. Furthermore, parts of the equipment mounted on the roof or mast may be susceptible to damage caused by a direct lightning strike or, at the very least, by the very large induced voltages or currents from lightning discharges flowing in and around sensors and their wiring.

The foregoing example shows that the possibility of transient voltages being introduced into electronic equipment in buildings depends not only on the lightning protection of the building itself but the installation details of the wiring and sensors on the tower and the route to the electronic equipment in the building. Guidance on measures to protect against these risks is given in C.7.

A further example of a common problem that can give rise to severe transient voltages is shown in Figure C.2c). There is a tendency for lightning discharge currents to follow the conducting paths formed by cables which interconnect buildings, so that the current may flow from a building that has been struck into a building which has not itself been struck. Currents of tens of kiloamps may flow in such links and protection against this phenomenon is essential. Suitable protection is described in C.7. Problems arising from current flow in data lines between separate buildings constitute one of the major risk categories.

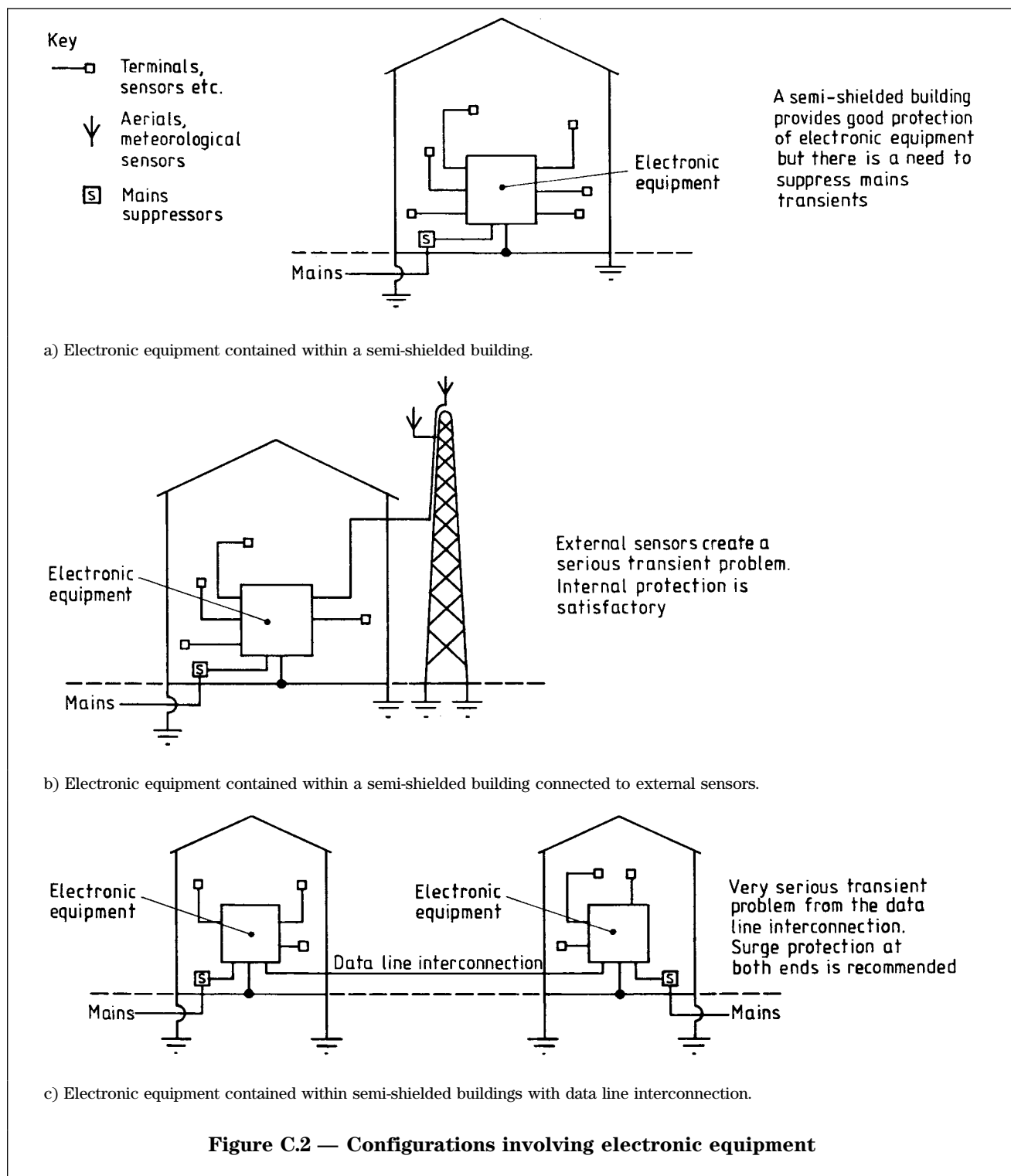

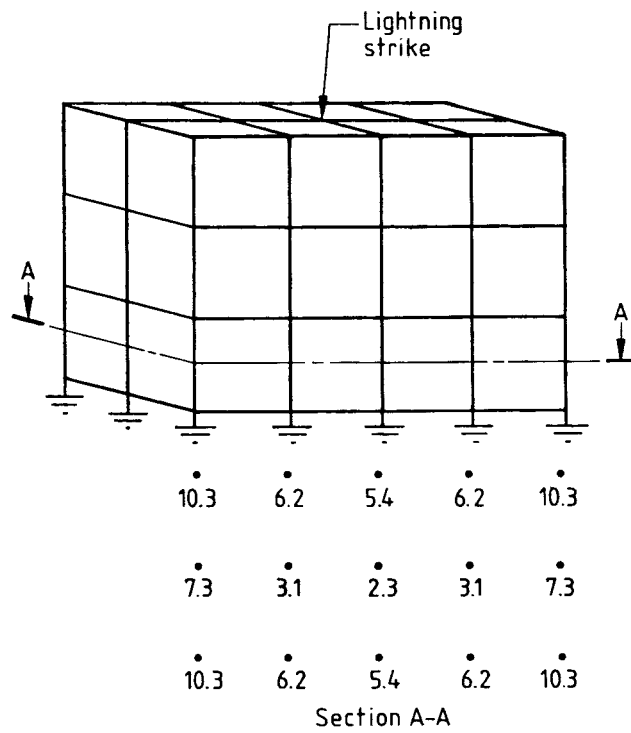

NOTE The figure shown against each stanchion is the percentage of the total lightning current flowing on that particular stanchion.

Figure C.3 — Lightning current distribution in a fifteen stanchion building

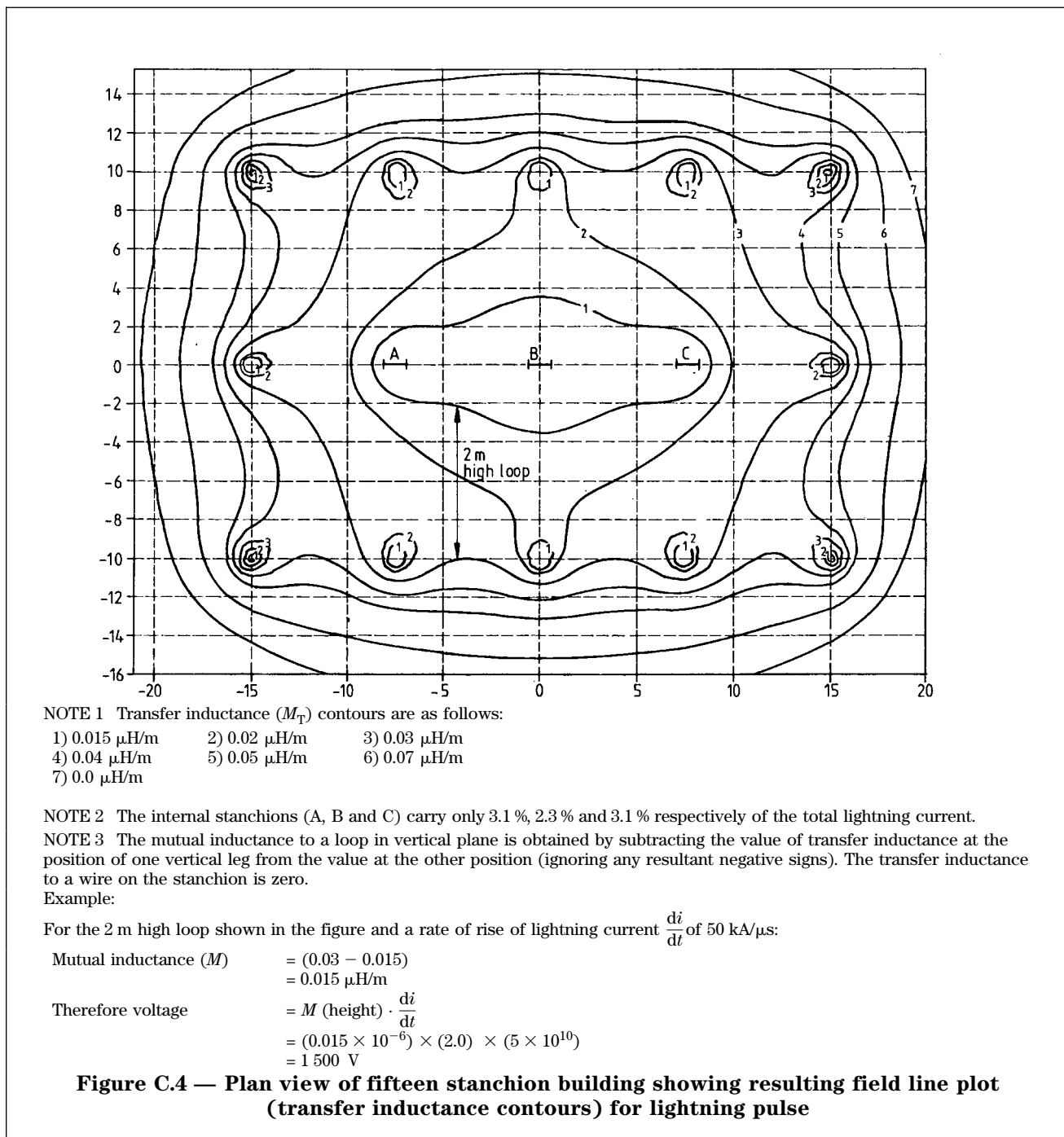

C.4 Risk assessment

C.4.1 Decision to install lightning protection

The decision whether to provide protection for electrical and electronic installations against the secondary effects of lightning depends on:

- the probable number of lightning strikes to the area of influence (see C.4.2);
- the vulnerability of the system configuration (see C.4.3).

C.4.2 The probable number of lightning strikes

C.4.2.1 Effective collection area

The probable number of lightning strikes to the effective collection area in any one year is given by the product of "lightning flash density" and the effective collection area.

The effective collection area, A_e in square metres (m^2) is given by:

A_e = area of structure + collection area of surrounding ground + collection area of adjacent associated structures + effective collection area of incoming mains services + effective collection area of data line leaving the earth reference of the building

C.4.2.2 Area of the structure

This area is the plan area of the structure.

C.4.2.3 Collection area of the surrounding ground

A lightning strike to ground or a structure causes a localized increase in ground potential. Any cables, e.g. mains or data lines, entering the area of raised ground potential will be subject to a common mode transient overvoltage. The effect of a ground strike will diminish as the distance between the perimeter of the structure and the strike point increases. There will be a certain distance beyond which a strike will have negligible effect. This is the collection distance D , in metres. For a typical $100 \Omega\cdot m$ resistivity soil, the distance D should be taken to be 100 m. For soil with other values of resistivity, the distance D should be taken to be numerically equal to the soil resistivity value up to a maximum value of 500 m for a soil resistivity of $500 \Omega\cdot m$ or greater.

The collection area of surrounding ground is the area between the perimeter of a structure and a line defined by the distance D away from it. Where the height of the structure, h exceeds D , the collection distance is assumed to be h .

C.4.2.4 Collection area of adjacent associated structures

The collection area of adjacent associated structures which have direct or indirect electrical connections to the electrical or electronic equipment in the structure being considered, should be taken into account.

Typical examples are external lightning towers supplied from the main building's electrical installation, other buildings with computer terminals, control and instrumentation equipment etc. and transmission towers.

At a site where several buildings are conductively-connected and are spaced at a distance less than $2D$, the collection area of the adjacent associated structure(s) is the area between the perimeter of the associated structure and a line defined by a distance D away from it. Any part of this area within the collection area of the structure being considered is disregarded. (See example 1 in C.6).

C.4.2.5 Effective collection area of incoming mains services

The effective collection areas associated with various types of mains services are shown in Table C.1.

All incoming and outgoing cables (e.g. to other buildings, lighting towers, remote equipment etc.) are considered separately and the collection areas summated.

Table C.1 — Effective collection area of mains services

Type of mains service	Effective collection area m^2
Low voltage overhead cable	$10 \times D \times L$
High voltage overhead cable (to on-site transformer)	$4 \times D \times L$
Low voltage underground cable	$2 \times D \times L$
High voltage underground cable (to on-site transformer)	$0.1 \times D \times L$
NOTE 1 D is the collection distance in metres (see C.4.2.3). The use of h in place of D , as explained in C.4.2.3, does not apply.	
NOTE 2 L is the length in metres of power cable with a maximum value of 1 000 m. Where the value of L is unknown, a value of 1 000 m should be used.	

C.4.2.6 Effective collection area of data lines leaving the earth reference of the building

The collection areas associated with various types of data line cables are shown in Table C.2.

If there is more than one data line cable, they should be considered separately and the collection areas summated. In the case of multicore cables, the cable is considered as a single cable and not as individual circuits.

NOTE A self-powered electronic circuit housed within an electrically continuous, metal-clad building and which has data lines that are free of conducting material will not be at risk from lightning. However, a data line containing conductors (not using a fibre optic cable) or a low voltage supply line, connected to the same electronic circuit could dramatically increase the risk of lightning damage.

Table C.2 — Effective collection area of data lines

Type of data line	Effective collection area m ²
Overhead signal line	$10 \times D \times L$
Underground signal line	$2 \times D \times L$
Fibre optic cable without a conductive metallic shield or core	0
NOTE 1 D is the collection distance in metres (see C.4.2.3). The use of h in place of D , as explained in C.4.2.3, does not apply.	
NOTE 2 L is the length in metres of the data line with a maximum value of 1 000 m. Where the value of L is unknown, a value of 1 000 m should be used.	

C.4.2.7 Assessment of the probability of a strike

The probable number of strikes to the defined collection area per year, p , is as follows:

$$p = A_e \times N_g \times 10^{-6}$$

where

A_e is the total effective collection area in square metres (m²);

N_g is the flash density per square kilometre per year.

C.4.3 Vulnerability of the system configuration

The overall risk of a strike to electrical or electronic equipment will depend upon the probability of a strike (p) and each of the following items:

- type of structure;
- degree of isolation;
- type of terrain.

In Tables C.3 to C.5, weighting factors F to H are assigned to each of the items to indicate the relative degree of risk in each case.

Table C.3 — Weighting factor F (type of construction)

Type of structure	Value of F
Building with lightning protection and equipotential bonding in accordance with BS 6651.	1
Buildings with lightning protection and equipotential bonding in accordance with CP 326.	1.2
Building where equipotential bonding for electrical or electronic equipment reference may be difficult (e.g. buildings over 100 m long.)	2.0

Table C.4 — Weighting factor G (degree of isolation)

Degree of isolation	Value of G
Structure located in a large area of structures or trees of the same or greater height, e.g. in a large town or forest.	0.4
Structure located in an area with few other structures or trees of similar height.	1.0
Structure completely isolated or exceeding at least twice the height of surrounding structures or trees.	2.0
NOTE Table C.4 has the same weighting factors as Table 11 but is repeated here to assist the user.	

Table C.5 — Weighting factor H (type of terrain)

Type of terrain	Value of H
Flat country at any level	0.3
Hill country	1.0
Mountain country between 300 m and 900 m	1.3
Mountain country above 900 m	1.7
NOTE Table C.5 has the same weighting factors as Table 12 but is repeated here to assist the user.	

C.4.4 Risk of a lightning strike to a particular system configuration

The risk of a lightning strike and the vulnerability of the system configuration (weighting factors) can be combined to assess the risk of a lightning strike coupling into electrical or electronic systems through either the incoming/outgoing mains service or incoming/outgoing data lines.

The risk of occurrence (R) of a lightning-induced transient overvoltage is given by:

$$R = F \times G \times H \times p \quad (\text{C.1})$$

NOTE The value of $1/R$ indicates, in years, the average period between lightning-induced overvoltages. It is emphasized that such average values are based on data collected over many years.

C.5 Decision to provide protection

The decision to provide protection should take into account the consequential effects of damage to important electrical and electronic equipment. Consideration should be given to health and safety hazards due to loss of plant control or essential services. The cost of computer system downtime or plant downtime should be compared with the cost of protection and prevention. A classification of structures and contents is given in Table C.6.

Table C.6 — Classification of structures and contents

Structure usage and consequential effects of damage to contents	Consequential loss rating
Domestic dwellings and structures with electronic equipment of low value and having a small cost penalty due to loss of operation.	1
Commercial or industrial buildings with essential computer data processing where equipment damage and downtime could cause significant disruption.	2
Commercial or industrial applications where loss of data or computer process control could have severe financial costs.	3
Highly critical processes where loss of plant control or computer operation may lead to severe environmental or human cost (e.g. nuclear plant, chemical works etc.).	4

For a particular installation of electronic equipment, the value of R is ascertained (see C.4.4) and the consequential loss rating is established from Table C.6. By using the values in Table C.7, it is possible to determine the exposure level to which the surge protection devices should be designed. (See C.13). Where the exposure level is negligible, protection is not normally necessary.

C.6 Sample calculations

Example 1

A commercial company's computing headquarters on the outskirts of Hull is 15 m high covering an area of 100 m in length by 60 m in width. Located in flat country, the building is largely isolated from other structures of similar height and is protected in accordance with BS 6651.

The incoming mains supply is a 250 m long LV underground cable and all computer communication lines are on fibre optic cable without metal armouring.

An underground cable provides power from the building to a lighting tower, 7 m high, 100 m from the building.

To determine what protection is necessary, the risk factors are calculated as follows.

a) *Number of flashes per square kilometre per year*

For Hull, a flash density of 0.6 per square kilometre per year is applicable. (See Figure 1).

Therefore $N_g = 0.6$

b) *Collection area*

1) Area of structure

$$= 100 \times 60$$

$$= 6\,000 \text{ m}^2$$

2) Collection area of surrounding ground

(see Figure C.5 and equation (1))

$$= 2(100 \times 100) + 2(100 \times 60) + (\pi \times 100^2)$$

$$= 63\,416 \text{ m}^2$$

NOTE It is assumed that D , the collection distance, is 100 m.

3) Collection area of adjacent associated structures (see Figure C.5)

$$= \frac{\pi \times 100^2}{2}$$

$$= 15\,708 \text{ m}^2$$

NOTE For simplicity, the area is assumed to be a semicircle.

4) Collection area of mains services (see Table C.1)

i) Incoming mains service

$$= 2 \times 100 \times 250$$

$$= 50\,000 \text{ m}^2$$

ii) Mains service to lighting tower

$$= 2 \times 100 \times 100$$

$$= 20\,000 \text{ m}^2$$

Total collection area of mains services

$$= 50\,000 + 20\,000$$

$$= 70\,000 \text{ m}^2$$

5) Collection area of data lines leaving the earth reference of the building

$$= 0$$

NOTE The collection area is zero due to the use of fibre optic cable.

The total effective collection area is:

$$A_e = 6\,000 + 63\,416 + 15\,708 + 70\,000 + 0$$

$$= 155\,000 \text{ m}^2$$

Table C.7 — Classification of exposure level

Consequential loss rating	Exposure level			
	$R < 0.005$	$R = 0.005$ to 0.0499	$R = 0.05$ to 0.499	$R > 0.5$
1	Negligible	Negligible	Low	Medium
2	Negligible	Low	Medium	High
3	Low	Medium	High	High
4	Medium	High	High	High

NOTE Exposure level categories in Table C.7 are based on a lightning risk assessment only. If transients of other origin are present, consideration should be given to upgrading protectors, e.g. if in an industrial area the risk assessment suggests a surge protection device suitable for a medium exposure level is appropriate, the presence of inductive switching transients may make a high exposure level device appropriate. In these circumstances, specialist/manufacturer's advice should be sought.

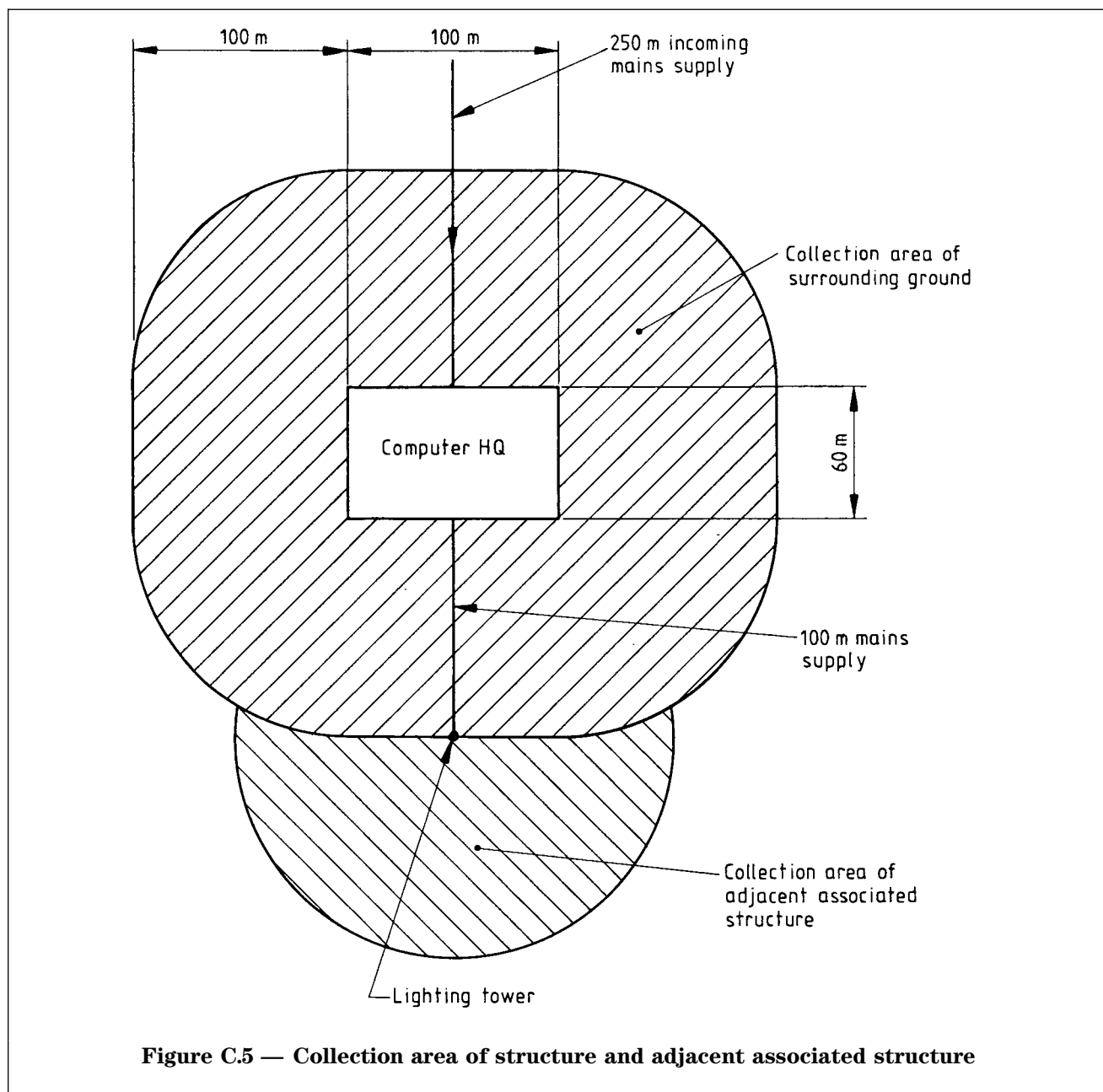

c) *Probability of a strike*

The probability of a strike to the effective collection area is given by equation (2):

$$\begin{aligned} p &= A_e \times N_g \times 10^{-6} \\ &= 155\,000 \times 0.6 \times 10^{-6} \\ &= 0.093 \end{aligned}$$

d) *Risk of occurrence*

The risk of occurrence of a lightning-induced overvoltage is given by the following.

1) For the whole site area:

$$\begin{aligned} R &= F \times G \times H \times p \\ &= 1 \times 1 \times 0.3 \times 0.093 \\ &= 0.0279 \end{aligned}$$

A value for R of 0.0279 indicates an occurrence of a lightning-induced overvoltage every 36 years on average.

2) For the site area associated with the incoming mains supply:

- i) $N_g = 0.6$
- ii) Collection area

$$= 6\,000 + 63\,416 + 15\,708 + 50\,000 = 135\,000 \text{ m}^2$$
- iii) Probability of a strike using equation (2)

$$= 135\,000 \times 0.6 \times 10^{-6} = 0.081$$
- iv) Risk of occurrence (R)

$$= 1 \times 1 \times 0.3 \times 0.081 = 0.0243$$

From Table C.6, the building is considered to have a consequential loss rating of 2.

From Table C.7, it is deduced that a surge protection device should be fitted, suitable for a low exposure level environment.

3) For the site area associated with the mains supply to the lighting tower:

- i) $N_g = 0.6$
- ii) Collection area

$$= 6\,000 + 63\,416 + 15\,708 + 20\,000 = 105\,000 \text{ m}^2$$
- iii) Probability of a strike [using equation (2)]

$$= 105\,000 \times 0.6 \times 10^{-6} = 0.063$$
- iv) Risk of occurrence (R)

$$= 1 \times 1 \times 0.3 \times 0.063 = 0.0189$$

From Tables C.6 and C.7, it is deduced that a surge protection device should be fitted, suitable for a low exposure level environment.

Example 2

A small water treatment control building in Lancashire has dimensions for height \times length \times width of 6 m \times 10 m \times 10 m respectively. Located in hill country, the building is isolated and is protected in accordance with BS 6651. The mains supply is by a 250 m long LV overhead line and an overhead telephone line of unspecified length provides a telemetry link.

To determine what protection is necessary, the risk factors are calculated as follows.

a) *Number of flashes per square kilometre per year*

For Lancashire, a flash density of 0.5 per square kilometre per year is applicable. (See Figure 1).

Therefore $N_g = 0.5$

b) *Collection area*

1) Area of structure

$$\begin{aligned} &= 10 \times 10 \\ &= 100 \text{ m}^2 \end{aligned}$$

2) Collection area of surrounding ground

$$\begin{aligned} &[\text{see Figure C.5 and equation (1)}] \\ &= 2(100 \times 10) + 2(100 \times 10) + (\pi \times 100^2) \\ &= 35\,416 \text{ m}^2 \end{aligned}$$

NOTE It is assumed that D , the collection distance, is 100 m.

3) Collection area of adjacent associated structures

$$= 0$$

4) Collection area of incoming mains services (see Table C.1)

$$\begin{aligned} &= 10 \times 100 \times 250 \\ &= 250\,000 \text{ m}^2 \end{aligned}$$

5) Collection area of data (telephone) lines (see Table C.2)

$$\begin{aligned} &= 10 \times 100 \times 1\,000 \\ &= 1\,000\,000 \text{ m}^2 \end{aligned}$$

NOTE It is assumed that L is 1 000 m since the length of the telephone line is unspecified.

The total effective collection area of the site is:

$$\begin{aligned} A_e &= 100 + 35\,416 + 0 + 250\,000 + 1\,000\,000 \\ &= 1.2855 \times 10^6 \text{ m}^2 \end{aligned}$$

The effective collection area associated with incoming mains services is:

$$\begin{aligned} A_{em} &= 100 + 35\,416 + 0 + 250\,000 \\ &= 285.5 \times 10^3 \text{ m}^2 \end{aligned}$$

The effective collection area associated with the data (telephone) line is:

$$\begin{aligned} A_{et} &= 100 + 35\,416 + 0 + 1\,000\,000 \\ &= 1.0355 \times 10^6 \text{ m}^2 \end{aligned}$$

c) *Probability of a strike* [see equation (2)]

The probability of a strike to the total effective collection area of the site is:

$$\begin{aligned} p_s &= A_e \times N_g \times 10^{-6} \\ &= 1.2855 \times 10^6 \times 0.5 \times 10^{-6} \\ &= 0.64 \end{aligned}$$

The probability of a strike to the effective area associated with incoming mains services is:

$$\begin{aligned} p_m &= A_{em} \times N_g \times 10^{-6} \\ &= 0.2855 \times 10^{-6} \times 0.5 \times 10^{-6} \\ &= 0.143 \end{aligned}$$

The probability of a strike to the effective area associated with the data (telephone) line is:

$$\begin{aligned} p_t &= A_{ec} \times N_g \times 10^{-6} \\ &= 1.0355 \times 10^6 \times 0.5 \times 10^{-6} \\ &= 0.52 \end{aligned}$$

d) *Risk of occurrence*

The risk of occurrence of a lightning-induced overvoltage is given by the following:

- 1) For the whole site area:

$$\begin{aligned} R &= F \times G \times H \times p \\ &= 1 \times 2 \times 1 \times 0.64 \\ &= 1.28 \end{aligned}$$

A value for R of 1.28 indicates an occurrence of a lightning-induced overvoltage every 9.4 months taken on average over a long period.

- 2) For the site area associated with the incoming mains:

$$\begin{aligned} R &= F \times G \times H \times p_m \\ &= 1 \times 2 \times 1 \times 0.143 \\ &= 0.286 \end{aligned}$$

From Table C.6, the site is considered to have a consequential loss rating of 3 since its loss of operation would disrupt the water supply to an entire town.

From Table C.7, it is deduced that a surge protection device should be fitted, suitable for a high exposure level environment.

- 3) For the site area associated with the data (telephone) line:

$$\begin{aligned} R &= F \times G \times H \times p_t \\ &= 1 \times 2 \times 1 \times 0.52 \\ &= 1.04 \end{aligned}$$

From Tables C.6 and C.7, it is deduced that a surge protection device should be fitted, suitable for a high exposure level environment.

C.7 Methods of protection of installations against lightning

C.7.1 Earthing, bonding and potential equalization

In the United Kingdom, there are less than 20 thunderstorm days per year. This is sufficiently low for the risk of damage to an electrical installation (e.g. wiring, switches, socket outlets) due to conducted lightning transients from low voltage power supply

lines to be negligible. Whilst damage to the electrical installation is negligible, damage to electronic equipment may still occur. In other countries where the ceramic level exceeds 25 thunderstorm days per year, protection against transient overvoltage for the electrical installation may be necessary if the structure is supplied via an overhead line.

NOTE The relationship between thunderstorm days per year and lightning flashes per square kilometre per year is given in Table 6.

Recommendations for earthing are given in clauses 17 and 18. The following recommendations complement them in order to improve earthing with the objective of achieving an equipotential reference plane such that electronic equipment is not exposed to differing earth reference potentials.

Incoming services for structures with extensive communication systems, e.g. industrial buildings, should be bonded to an equipotential bonding bar which is normally in the form of a metal plate, an internal ring conductor or a partial ring conductor at the inner side of the outer walls or at the periphery of the volume to protect near ground level as appropriate. This equipotential bonding bar is connected to the ring earth electrode of the earthing system. An example is shown in Figure C.6.

All external metal pipes, electric power and data lines should enter and leave the building at one point so that the armouring, etc., can be bonded to the main earthing terminal at this single point of entry (see Figure 30). This minimizes lightning currents crossing the building internally (see Figure C.7). Where power and data line cables pass between adjacent structures, the earthing system should be interconnected and it is beneficial to have many parallel paths to reduce the currents in individual cables. Meshed earthing systems fulfil this objective. Lightning current effects may be further reduced by enclosing the cables in metal conduits, trunking, ducts, etc., which should be integrated into the meshed earthing system and bonded to the common cable entry and exit earth point at both ends. Figure C.6 shows a typical example of a mesh earthing configuration for a tower and adjacent equipment building.

Similar principles to those which apply to the tower illustrated in Figure C.6 also apply to sensors or controls for well equipment (oil, water, etc.) where the bonding should include connections to the steel pipe of the well to reduce the potential difference between the well and the wiring. This bonding should then be interconnected to any other building earth to which the data line cables run.

Structures associated with masts should have the extra protection of their own dedicated power supply or be provided with an isolating transformer.

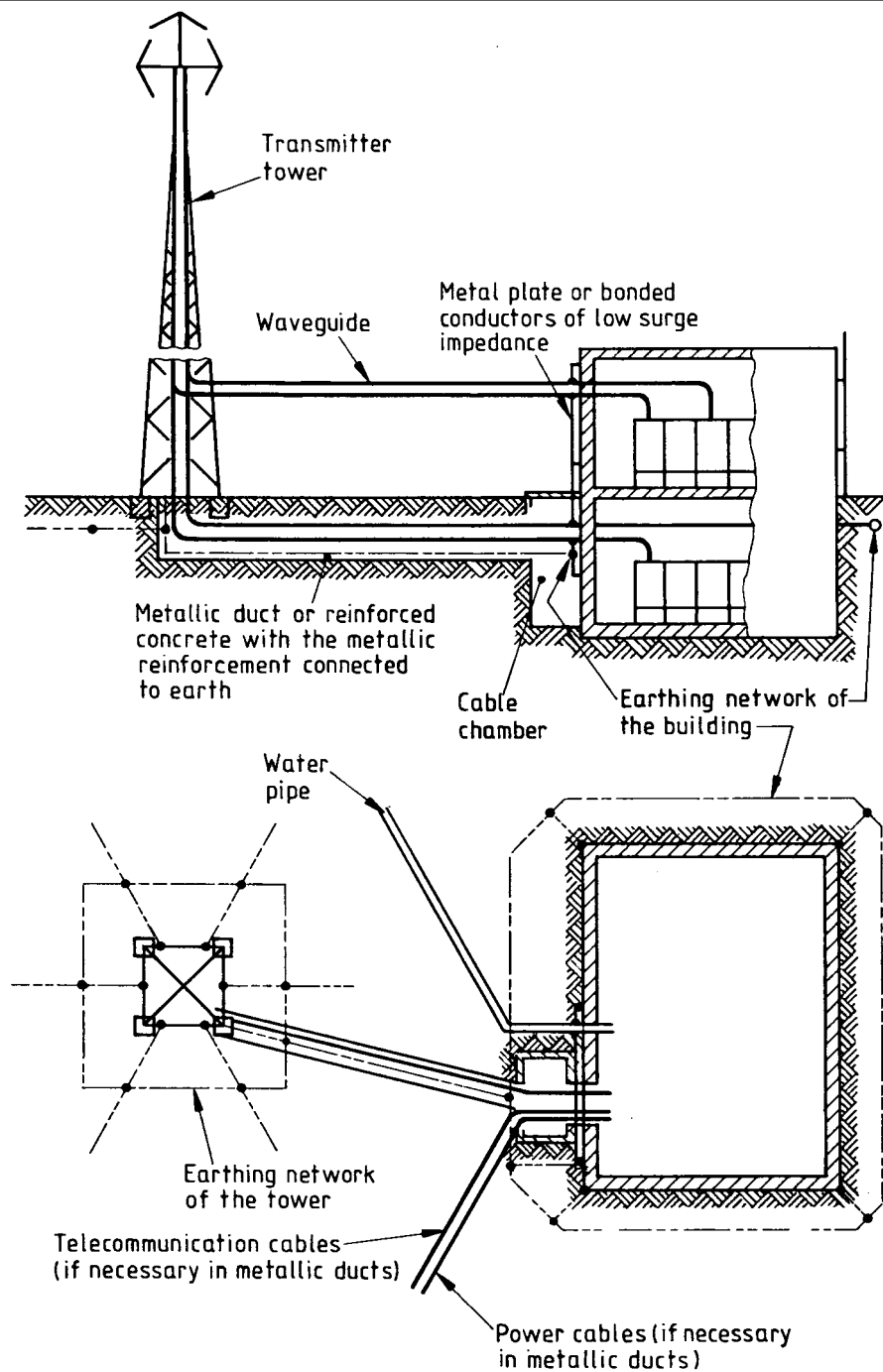

NOTE All cables, ducting etc. enter a building at the same point.

Figure C.6 — Cables entering a building separated from a transmitter mast

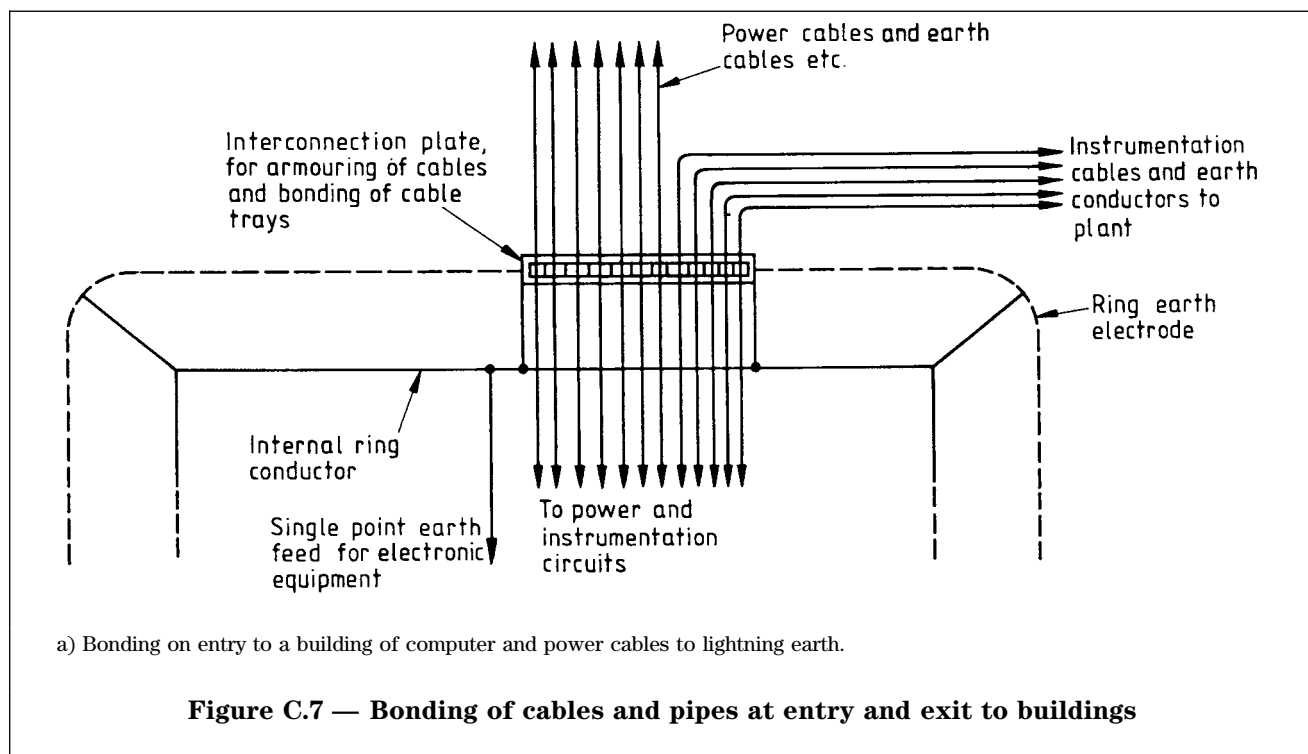

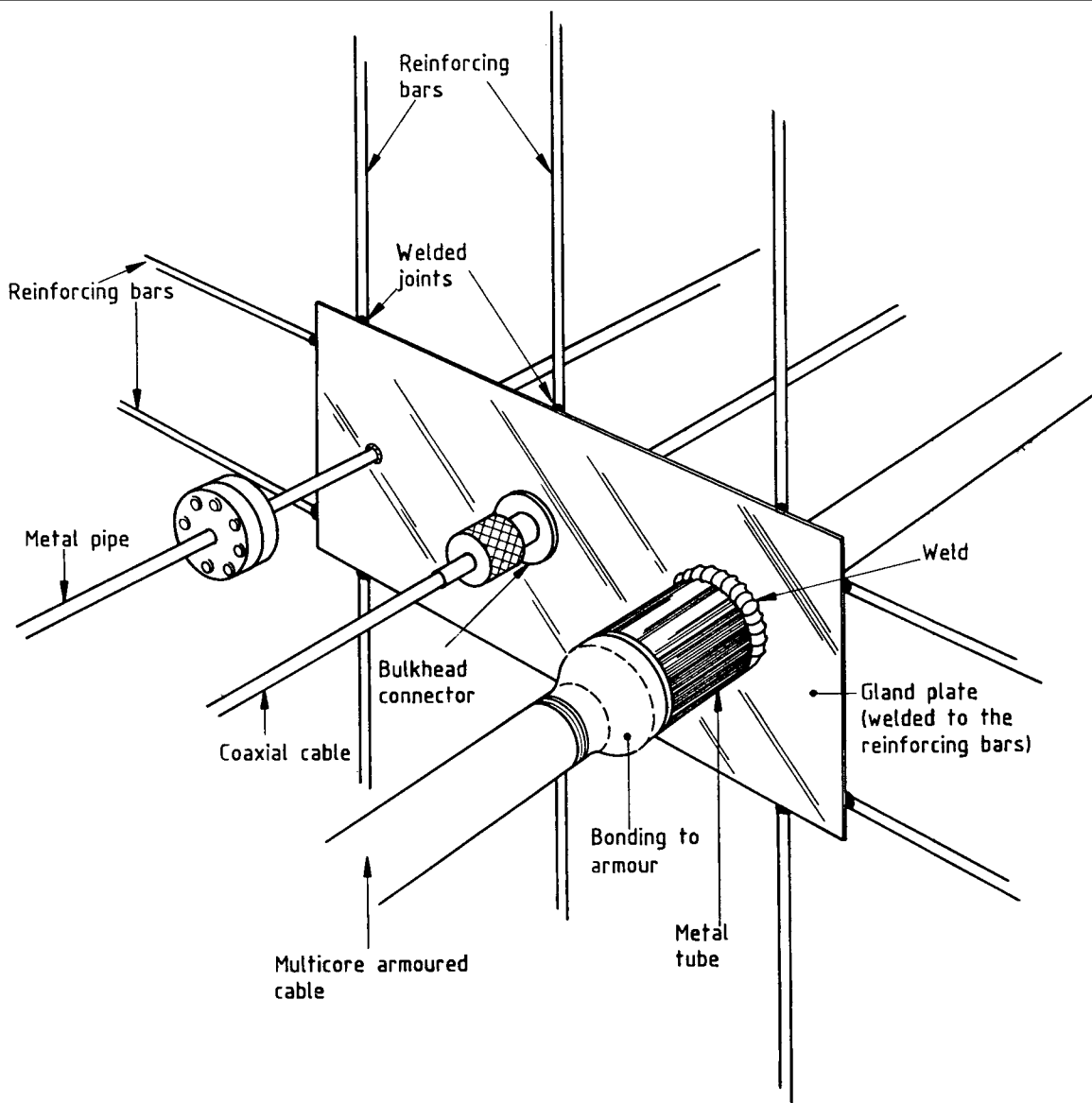

b) Grounding at entry for pipes, r.f. cables etc. in reinforced concrete wall, where maximum protection is needed.

NOTE A similar method to that shown in b) is recommended for pipes, cables etc. entering a sheet metal wall of a building.

Figure C.7 — Bonding of cables and pipes at entry and exit to buildings (continued)

C.7.2 Location of electronic equipment and cables

C.7.2.1 Location of electronic equipment within buildings

The choice of location for electronic equipment in a building depends on the building construction. For a building resembling a screened room, i.e. bonded metal-clad roof and walls, the location is not critical. In conventional modern metal framed buildings, the electronic installations should preferably be located in the centre of the building, and preferably should not be on the top floor where they are adjacent to the roof air terminations and roof lightning mesh. Nor, in preference, should the installations be positioned near outside walls, especially in corners of buildings. For a building comprising essentially non-conducting materials but with a lightning protection system, the same recommendations apply. In buildings of non-conducting materials which house electronic installations, considerable care should be taken in assigning location and specialist assistance should be sought. In particular an electronic installation (including its cabling) should not be located in a building adjacent to a tall structure, e.g. chimney, mast or tower, which could give high local fields when lightning current passes down this single route to ground.

C.7.2.2 Location of cables between items of electronic equipment within the building

Figures C.8 and C.9 illustrate the principal recommendations for internal wiring. As in the case of the computer location, the routing and location of wiring within a screened room building is not critical but it is none the less good practice to follow the recommendations for metal framed buildings. Avoidance of large area loops between the mains supply and the electronic installation wiring is strongly recommended.

It is desirable to run mains wiring and electronic equipment cables side-by-side to minimize loop areas. This can be achieved by using a pair of adjacent ducts or a duct containing a metal partition between the cables. In Figure C.9, meshed earthing is employed locally on the floor of the building and star point earthing is used overall. This combination of earthing systems is known as hybrid earthing.

Wiring to electronic equipment within the building should not be installed adjacent to possible lightning carrying conductors, e.g. roof conductors, external wall conductors. Wiring should be at floor level and should avoid loops in the vertical plane. Wiring between floors should be as in Figure C.9. The layout shown in Figure C.9 can also be used for equipment laid out horizontally in several adjacent rooms of a long building, in which case the metal trunking should be rearranged horizontally to join together separate blocks of equipment.

For buildings constructed of non-conducting materials, the wiring layout described in this subclause is essential to minimize damage to equipment or corruption of data. Where these wiring layout recommendations in this subclause for wiring layout are not practical, the use of surge protection devices is recommended and specialist advice should be sought.

C.7.3 Protection of building-to-building data lines

Where data lines pass between separate buildings, or between separate sections of one building which are not structurally integral (e.g. new wings added to a building joined by brick corridors, etc. or sections of a building separated by expansion or settlement gaps which are not bonded across), special care should be taken regarding protection.

Where possible, fibre optic links should be used to isolate completely the electronic circuits of one building from the other. This is the optimum method for multi-channel data links for complete freedom from electromagnetic compatibility (EMC) problems of all kinds, not only lightning. However it is recommended that fibre optic cables with metal armouring or draw wires inside should not be used. (If such cables are used, the armouring and draw wire should be bonded directly or indirectly via surge protective devices to the main cable entry bonding bar at its entry point into each of the buildings. No further bonds to the fibre optic cable armour or draw wire should be made.)

Where fibre optic links are not an option and conductive data lines are needed, e.g. wire pairs, or coaxial cables or LANs, precautions should be taken to prevent damaging transients flowing along the line causing multiple damage at both ends. Earthing systems of structures should be interconnected using the armour on cables, braids or metal trunking, raceways, conduits, etc., which are electrically continuous and bonded to the earth systems of the buildings at each end. In industrial installations, the armouring on multiple pair cables should be bonded at both ends to the structure. Where many such cables are available in parallel, very good interlinking of the system exists, resulting in very low induced voltage in the instrumentation loops (for sample calculations see C.10). In addition, earth cables should be installed to provide positive links from structure to structure.

Where coaxial cables are installed between buildings, the conductive sheaths of these cables should be bonded to the earthing system of the building at the entry/exit point of the building.

In certain types of coaxial or screened systems, it is permissible to bond the cable only once to earth.

Where necessary a suitable surge protection device should be used to provide additional bonding. (This is the case in certain types of LAN and details are given in ECMA 97 [3]) In most cases, protection is also necessary for the inner core(s) within a coaxial cable (see C.11).

Where only one or a small number of lines go from building to building, as in the case of instrument data or telephone lines, and where fibre optics are not an option, surge suppressors should be fitted which will crowbar (or clamp) the anticipated partial lightning current to earth, e.g. with a gas tube or semiconductor crowbar (or clamp) device and allow only a "let-through" voltage within the appropriate level for the equipment. A typical system for the earthing of surge suppressors is shown in Figure C.10. Recommendations for surge protection devices are given in C.13.

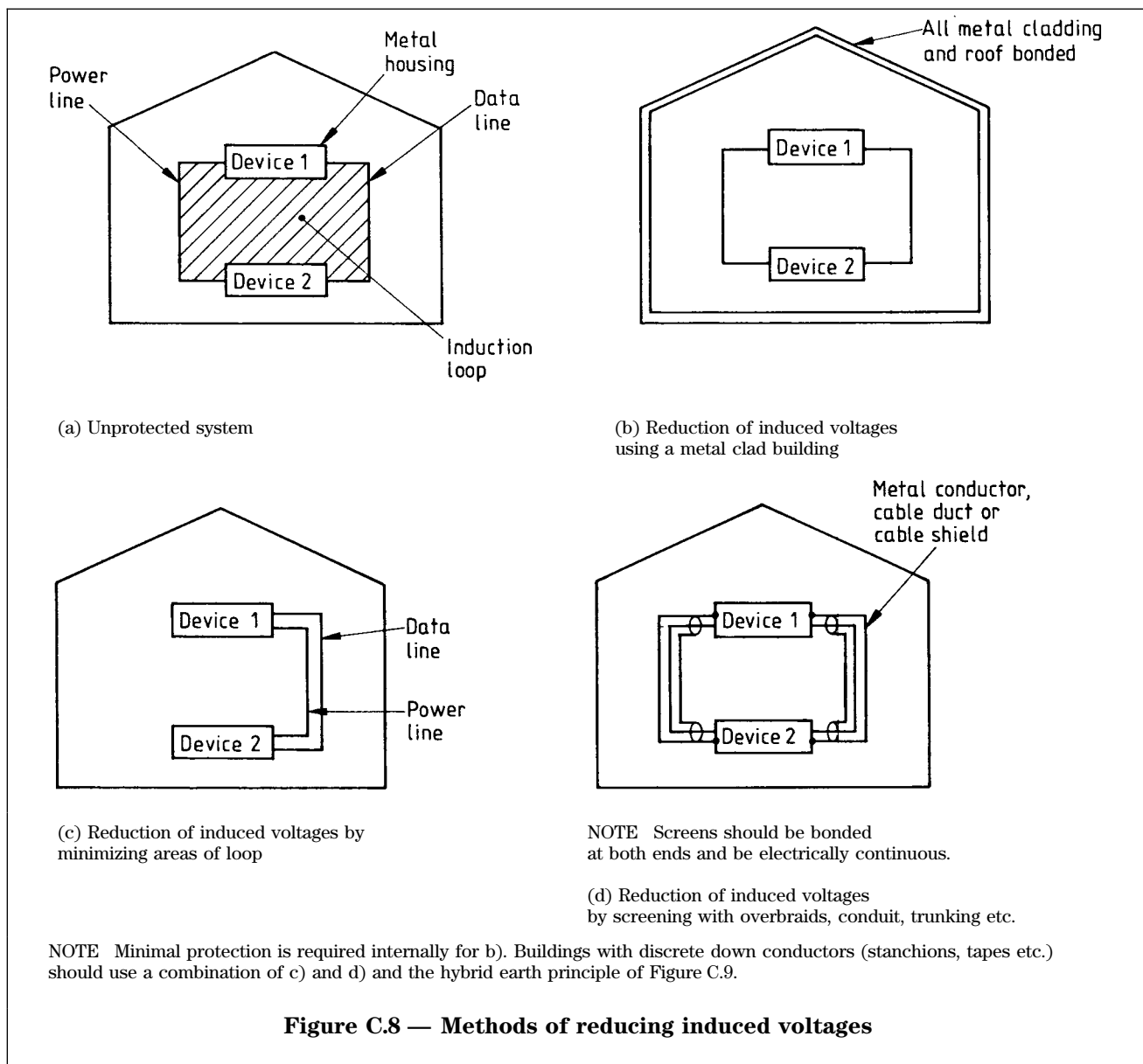
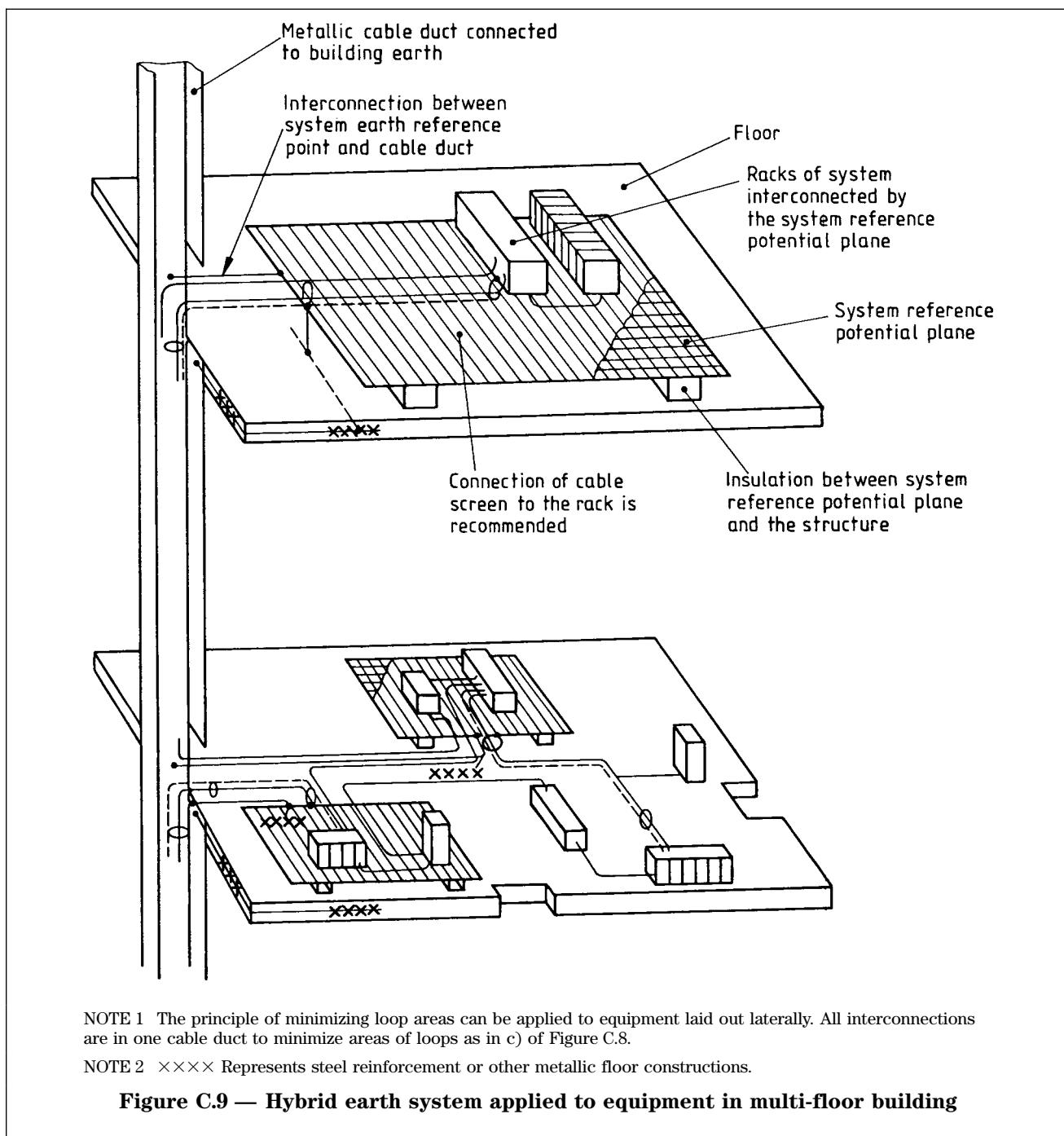
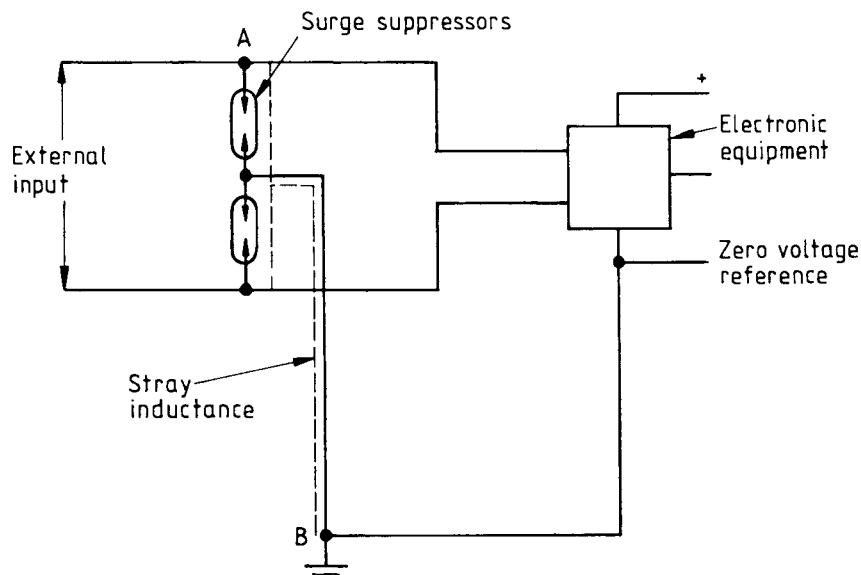

Figure C.8 — Methods of reducing induced voltages





a) Incorrect installation of surge suppressors giving rise to large transients.

NOTE These transients can arise from the earth line inductance to the earth reference point B.

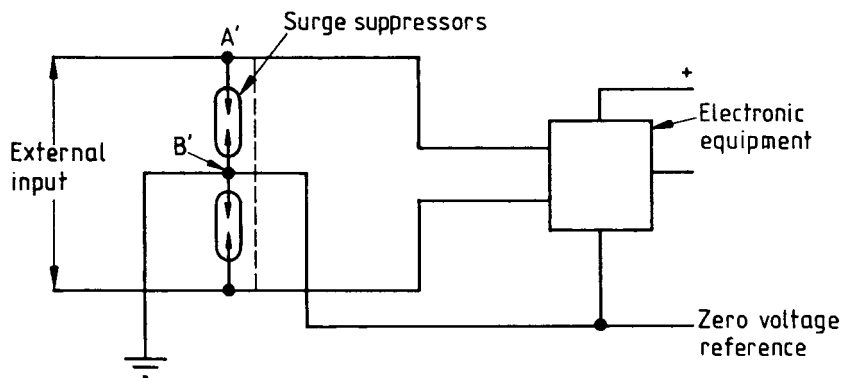

b) Recommended installation of surge suppressors.

NOTE Transients minimized by connecting the zero voltage reference to earth reference point B' by the most direct route.

Figure C.10 — Earth connection from zero voltage reference of equipment to earth of surge protection devices

A combination of the methods discussed in this subclause is possible, e.g. using opto-isolator devices for signal or instrumentation lines (including intrinsically safe systems within a potentially explosive atmosphere) in conjunction with bonded armouring of cables to keep transients within an acceptable voltage range. Except in the case of long fibre optic links, high impedance isolation devices are not satisfactory on their own unless they have a withstand voltage greater than 100 kV owing to the large potential difference occurring between unprotected buildings resulting from lightning current flow into the ground from one of them.

C.7.4 Protection of equipment having component parts on the outside of buildings or connected to towers, masts or process vessels

Where component parts of equipment are mounted on the outside of buildings (i.e. on the side walls or roof) or are connected to towers, masts or process vessels the following hazards exist.

- a) *Current injection from a direct strike.* Current injection from a direct strike should be prevented wherever possible by suitably placed air terminations, covers, enclosure of sensors and wiring in order to minimize the chance of a direct lightning strike to sensors and wiring (see Figures C.11, C.12 and C.13). Cables attached to masts should be located within the mast to give protection from direct injection, using, for example, a shroud diverter. Where whip aerials etc. cannot be protected from strikes by an air termination, some form of protection, such as a shroud diverter, should be incorporated at the base of the aerial to limit any surge currents into the down leads.
- b) *Inductive and resistive voltages.* The protection methods described in item a) to prevent strike contact to electronic equipment, wiring and exposed items (sensors, aerials, etc.) will reduce resistive and inductive voltages. Wiring should be installed in metallic conduits or in locations where the structure provides suitable screening e.g. for steel lattice towers, inside the corners of the L-shaped section members or within metal tubular masts (see Figure C.14). In Figure C.14, the relative values of currents to be expected in individual cables in four positions are given. From the braid or sheath resistance and length, the induced voltage can be estimated. See C.12 for a sample calculation. Where the wiring uses a low partial current route and is screened, induced voltages will be minimized. However very short bonding leads at each end of shielding, braided tubes etc. should be used to reduce inductive voltages. This technique is satisfactory where the induced voltages can be shown to be less than the immunity level (see 3.1.18) of the equipment being protected. Where the induced voltage cannot be restricted to less than the immunity level, surge protection devices should be fitted.

Overall protection for a tower and its associated equipment building is shown in Figure C.6 and illustrates many of the points described above including routeing, screening, bonding, interconnection of earths, etc.

NOTE This is recommended in CCITT Publication, *The protection of telecommunication lines and equipment against lightning discharges*, Chapter 6, *Protective practices for specific parts of telecommunications networks* 1978. [4]

C.8 Characteristics and effects of lightning

NOTE For the general characteristics of lightning, see 4.2.

C.8.1 Additional characteristics of lightning relevant to electronic equipment

The maximum rate of rise (di/dt) values are as follows:

Maximum rate of rise (di/dt) kA/ μ s	Strokes exceeding di/dt %
200	1
30	50
10	99

Other parameters of the lightning pulse are important for other aspects of lightning damage, but peak current and peak di/dt are the principle ones for interference voltage considerations, and the duration of the pulse is significant for the energy ratings of suppressors. The representation of a severe negative strike to ground is shown in Figure C.15.

Lightning-induced transients can have two major effects on electronic equipment. The most serious is equipment damage which might easily be caused by a single stroke. The second major effect, which is computer data and software corruption or disturbance ("upset"), might also be made worse by the multiple pulse aspect of lightning. The combination of the first return stroke plus numerous re-strikes (as many as twenty in a severe case), all occurring in a period of 1 s to 2 s, can cause considerable problems for the correct operation of a computer, unless error checking is used, which can reject "nonsense" data for periods up to 2 s.

C.8.2 Strike points for lightning

The positions of strike points to level terrain are very random, although tall trees and houses may be slightly more at risk than small trees and houses. However strikes to flat ground between buildings are quite common when the buildings are separated by a distance of more than twice the height of the individual buildings.

In process plant installations, strike locations will tend to favour chimneys, taller fractionating columns, tall lamp posts etc. so minimizing strikes to parts of the plant close to these tall features. However, parts of buildings which are outside the 45° cone of protection of the tall buildings are liable to be struck. (See Figure C.16).

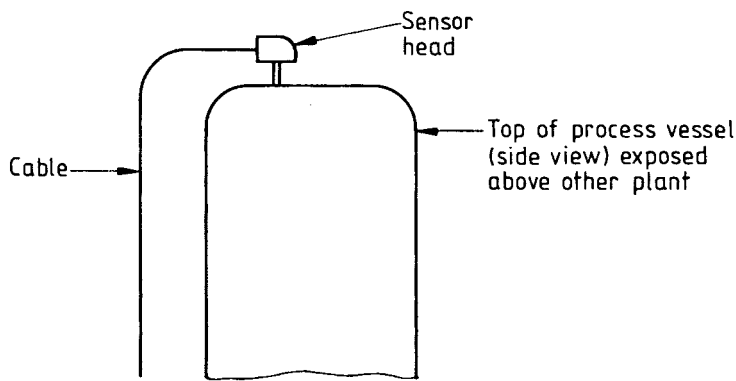

a) Exposed sensor and cable on process vessel.

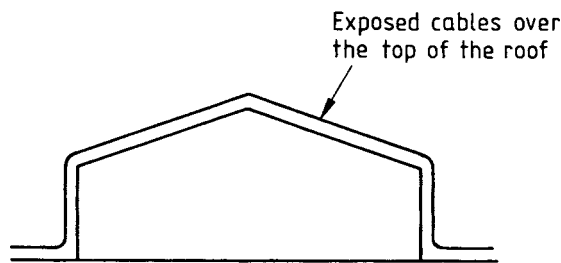

b) Exposed cable on roof.

Figure C.11 — Direct injection into exposed electrical systems

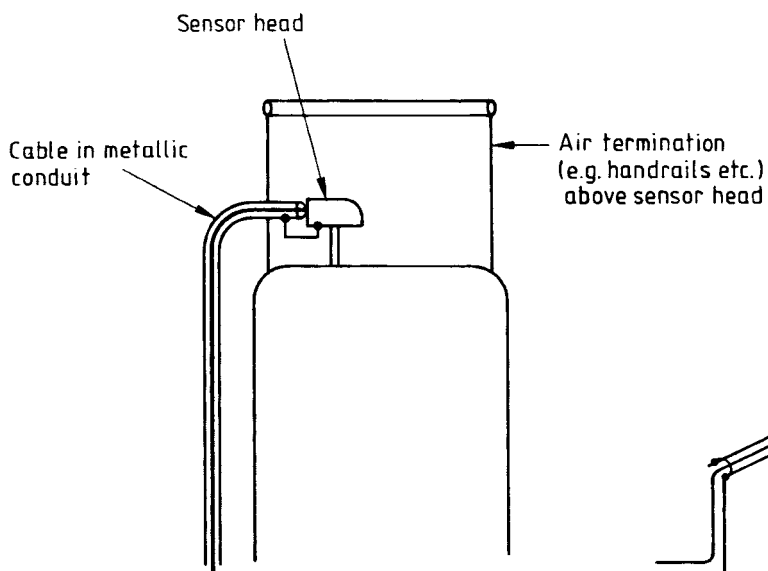

a) Exposed sensor and cable on process vessel

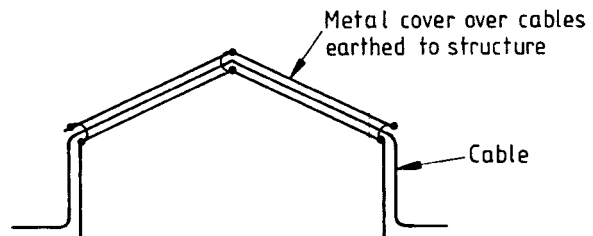

b) Exposed cable on roof

Figure C.12 — Protection from direct injection

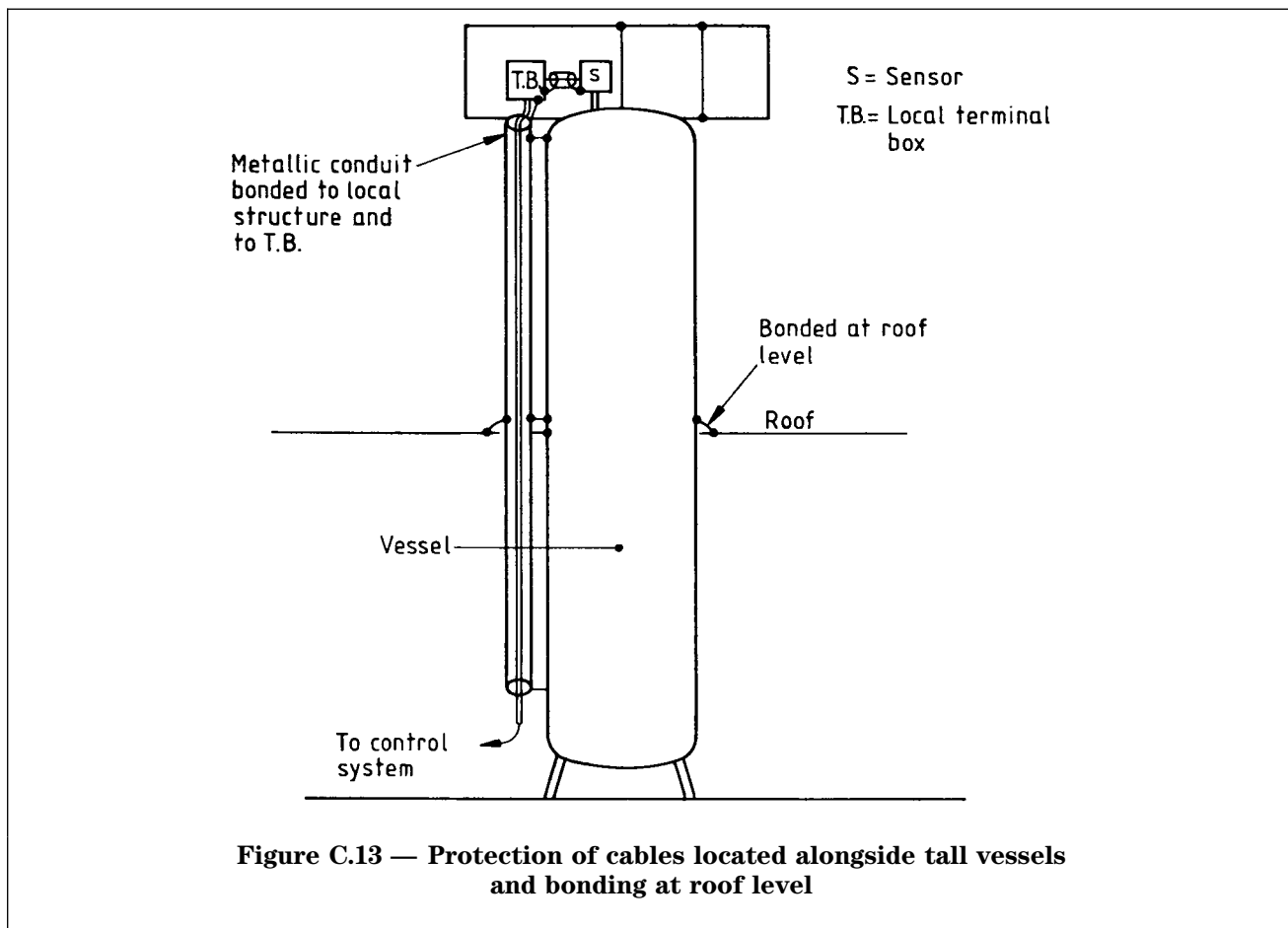

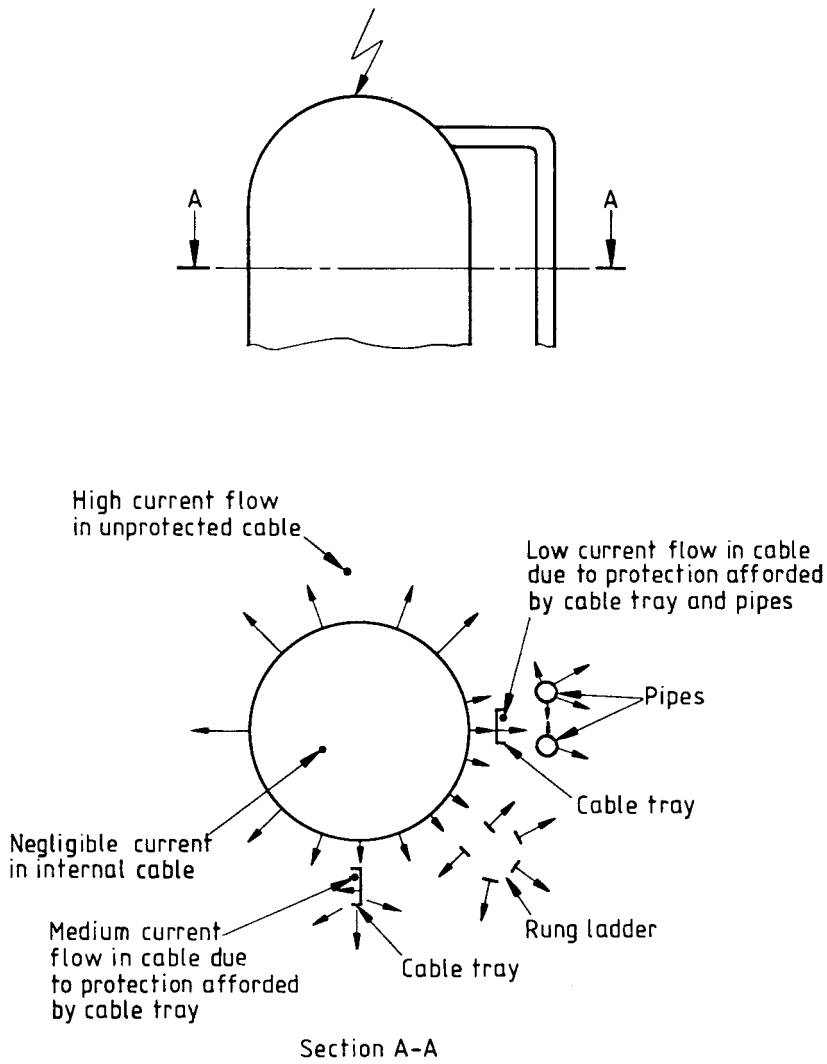
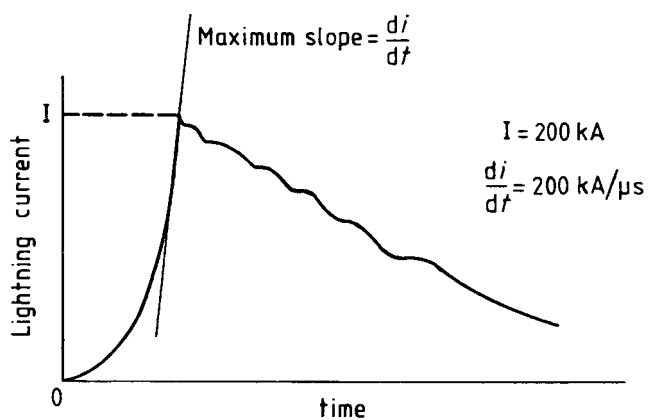
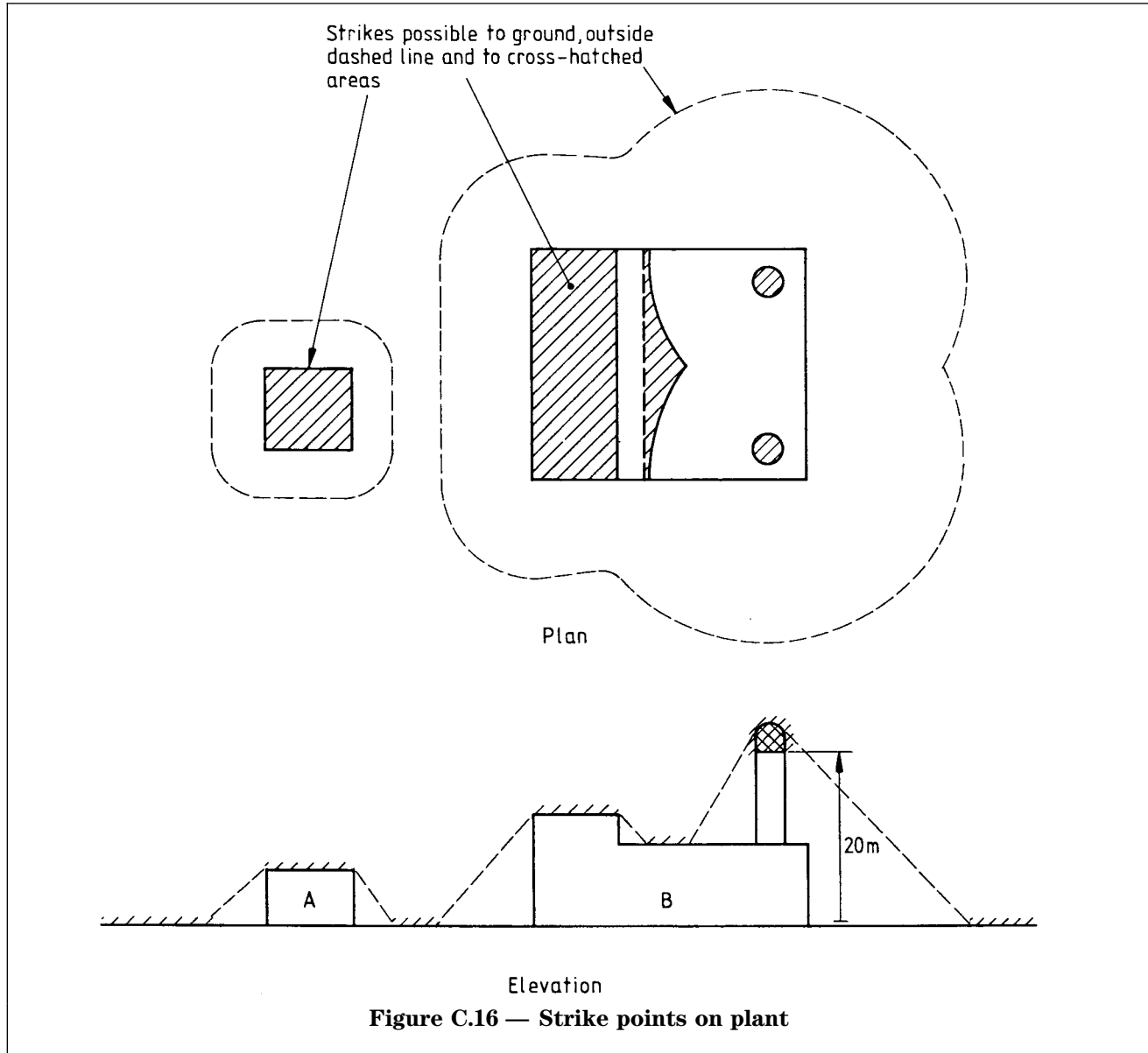

Figure C.14 — Locations where high, medium or low lightning current can be expected to flow through cables associated with a reaction vessel



NOTE The initial strike may be followed by several shorter duration lower amplitude pulses of current called subsequent strikes or restrikes.

Figure C.15 — Lightning current characteristics for severe negative strike



Electronic equipment on towers or tall buildings is especially at risk, not only because of the risk of direct strike, but also because of the relatively high exposure of wiring and other associated equipment. Such systems should be carefully protected.

A notional process plant in plan and elevation showing areas subject to being struck is illustrated in Figure C.16. For buildings up to 20 m in height, the 45° cone of protection system is a good working rule in considering lightning protection. However, for tall buildings, towers, etc. (over 20 m tall), the rolling sphere method is better for identifying vulnerable areas, especially as it permits an assessment of the tendency for strikes to occur to the sides of such structures. A rolling sphere radius of 20 m is recommended.

In Figure C.16, it is assumed that electronic equipment is located within buildings A and B and that there are connecting cables between. However, it can be seen that strikes are possible to A and to parts of B, as well as to the ground around them both. Thus, in such an example, ground currents from nearby strikes to ground, or to connected or unconnected buildings need to be taken into account in assessing the nature and extent of the protection that is necessary.

C.9 Lightning-induced transients and protection principles

NOTE This clause describes the induced voltage coupling mechanisms, magnitudes, waveshapes and provides guidance on establishing safe transient levels by the TCL/ETDL principle. (See 3.1.18, 3.1.19 and C.9.6.)

C.9.1 Resistively-induced voltage

When a building is struck by lightning, the current flow into the earth develops a large voltage between the building structure, metalwork and the lightning protection system, considered as a whole, and a remote earth. This large voltage is one of the reasons that lightning current flows in the external conducting parts (e.g. cables) which are bonded to the building and run to remote earths. The voltage so produced is primarily a resistive voltage but on the fast rising part of the lightning waveform, inductive and transmission line effects will also occur at least to a small extent.

Any current flowing in cable screens and armouring results in resistive voltages which are injected by way of the wiring into electronic equipment as common mode voltages at both ends of the cable.

For that part of the spectrum of the lightning pulse where there is the most energy, say up to 100 kHz, earth resistance and cable screening, armouring, etc. act as resistors so producing resistive voltages similar in waveform to the lightning current pulse. However in certain circumstances (e.g. long underground sheathed cables) considerable elongation of the current pulse will occur (up to perhaps 1 000 μ s) and the design of protection equipment should take this into account.

C.9.2 Inductive voltage

Lightning current, either flowing in a conductor or in the arc channel, produces a time-varying magnetic field, which at distances up to 100 m is proportional to the time-varying current. This time-varying magnetic field produces two effects:

- a) a magnetic self-inductance L in a cable carrying the current (e.g. for a typical wire about 2 mm in diameter $L = 1 \mu\text{H/m}$);
- b) a mutual coupling to loops incorporating the current carrying conductor (transfer inductance = M_T) or in completely separate loops (mutual inductance = M).

In each case, the voltages produced are proportional to di/dt multiplied by L , M_T or M (see Figure C.17.).

Also, for a single conductor carrying the current, the field strength is inversely proportional to the distance from the conductor. For a more complex situation, calculations can evaluate L , M_T or M . For example lightning currents passing down the stanchions of a 15 stanchion building shown in Figure C.4 give contours of constant M_T relative to the stanchion. This enables calculations of mutual and transfer inductive voltages to be performed as given in the example in Figure C.4.

It is also important to take into account the inductance of earth leads to equipment and surge suppressors and "pigtail" earthing of cable screens.

C.9.3 Current injection from direct strike

Direct lightning strikes to installation wiring or exposed electrical systems such as sensor heads or aerials (see Figure C.11) may inject sufficient current into the wires to cause explosive vaporization. This can cause considerable physical damage to the installation wiring over a considerable length. Enclosures for the wiring e.g. plastics or metal conduits or trays and other items very close to the wiring could also be split apart or damaged.

Owing to the very high voltages associated with direct injection, damage to other circuits is possible as a result of high voltage breakdown and flashover on the terminal blocks, plugs and sockets, etc. so injecting large currents or voltages into the other circuits and causing multiple failure in them. This is particularly relevant to situations involving potentially explosive atmospheres. By suitable relocation of wiring, wiring covers and/or the fitting of a suitable air termination, such direct contact should be prevented. (See C.7.4).

C.9.4 Electric field coupling

Field strengths have to be taken into account in the whole striking area immediately before the formation of the main discharge when their values are close to the breakdown strength of air (approximately 500 kV/m).

At the formation of the main discharge, the field breaks down and field changes of approximately 500 kV/m- μ s can occur. The effects of such a field change are not normally a serious problem since protection against the resistive and inductive effects of lightning will also give protection from electric field coupling.

C.9.5 *Lightning electromagnetic pulse- (LEMP)-induced voltage*

The term LEMP (see 3.1.23) was coined to correspond with another electromagnetic phenomenon, namely nuclear electromagnetic pulse (NEMP). There are important differences in the spectrum and magnitude of the two effects since NEMP produces much faster rising pulses (a rise time of 10 ns) with very severe amplitude, and the NEMP only interacts with systems as a radiated pulse. By comparison the radiated pulse from lightning is relatively small. Strikes either to the building under consideration or to the ground nearby do not produce true LEMP but principally a near-field magnetic coupling which gives inductive voltages (and resistive voltages) as described in C.9.1 and C.9.2.

Lightning-induced electric field pulses within buildings containing electronic equipment are usually negligible. In exceptional cases, external wiring might be at risk, unless it is screened or enclosed (which in any case is necessary for protection against injected currents and induced voltages).

In general, the worst effects of LEMP are prevented by adopting precautions necessary for protection against direct lightning strikes. Direct strikes in any case produce much more severe transients than LEMP and direct strike protection is of primary importance, the protection against LEMP being a secondary advantage and so ensuring that LEMP effects are negligible.

C.9.6 *Transient control level (TCL)/Equipment transient design level (ETDL) principle*

For any electronic equipment operating in any transient or other interference environment, protection can be designed to provide any degree of protection which is economically feasible or necessary on safety or other grounds.

Once the pass/fail criteria are determined for equipment, (e.g. no damage to internal components) suitable tests will demonstrate the maximum level of transients, called the ETDL, at which the equipment will operate successfully. In the case of lightning, this means that up to say N volts of transient, applied in common or differential mode, the equipment will not suffer component damage. The equipment then has an ETDL of N volts. When installing the equipment it is necessary to ensure that transients in the wiring connected to the equipment are at a level of say P volts, which will be below the ETDL of N volts, (to allow for ageing, safety factors in the calculations, etc.). P is called the transient control level (TCL) and $N - P$ is called the safety margin.

To determine whether a surge protection device can control a transient voltage to within the desired transient control level, its let-through voltage, with a voltage waveform of appropriate severity, should be established.

Matching the ETDLs of equipment within the installation with the transient level of the installation will ensure a safe system, provided attention is paid to earthing and bonding techniques to maintain low transient levels. In particular, attention has to be paid to electronic equipment and surge protection device earthing to prevent significant resistive, and especially inductive voltages, which occur on protector device earth leads from being added to the basic protector let-through voltage.

C.9.7 *Protection principles*

C.9.1 to C.9.5 refer to the various coupling mechanisms from lightning. Except in the case of very exposed aerials, equipment protected against the resistive/inductive effects of a lightning strike on or close to a building will be protected from the electric field and the LEMP aspects of it.

Direct injection of lightning current into electronic equipment should be prevented owing to the very serious damage caused (see C.7.4). A major factor in the importance of resistive and inductance voltages is that they are both injected with low source impedance hence the resulting energy in the transients is much higher than those available from either LEMP or electric field coupling. Therefore it is the magnitude of resistive- and inductive- induced voltages and currents which provide the basis for a quantitative assessment of transients and the specifications for protection devices.

Lightning protection should therefore protect against the high voltage which might result from a strike, and which can cause large currents to flow into cables and arrestors due to the low source impedance.

For protection techniques to be successful, the following conditions should be satisfied.

- a) *Survivability.* Protection devices or techniques should be able to survive the full severity of transient overvoltages to be encountered at the device location.
- b) *Transient control level.* Protection should achieve a transient control level below the ETDL of the equipment being protected. Surge protection techniques such as connecting leads and earth cables may add significantly to the transient control level achieved.
- c) *System compatibility.* Any form of protection added should not interfere with the normal operation of the system to be protected.

Particular care may be necessary for the protection of high speed communication systems and intrinsically safe circuits. For applications in potentially explosive atmospheres, attention should be paid to the provisions of BS 5345-4.

C.10 Sample calculations of induced voltage in instrumentation loops

The sample calculation of induced voltage involves the use of armouring as part of the earth interconnection system of many parallel instrument cables spreading out to a plant.

Take the case of 100 cables with aluminium armouring, say 65 strands of 1 mm diameter on each cable with a resistivity of $3.0 \times 10^{-8} \Omega\cdot\text{m}$, cables 100 m long.

$$\begin{aligned} \text{Resistance of each cable} &= \frac{\rho \times l}{A} & (8) \\ &= \frac{3.0 \times 10^{-8} \times 100}{65 \times 0.001^2 \times \frac{\pi}{4}} \\ &= 59 \text{ m}\Omega \end{aligned}$$

where

ρ is the resistivity;

l is the length of the cable;

A is the cross-sectional area of the armouring.

For 100 cables in parallel, each taking one-hundredth of the total current of say 100 kA flowing from computer room to plant, the current would be 1 kA per cable.

Therefore the common mode induced voltage is given by:

$$\begin{aligned} V &= R \times I \\ &= 59 \times 10^{-3} \times 1 \times 10^3 \\ &= 59 \text{ V} \end{aligned}$$

In practice, the current distribution among the cables will not be uniform, but with the assistance of other earth cables in parallel with the instrument cables and also power cables with their armouring bonded, the current in each of the instrument cables is unlikely to exceed 1 kA by a large factor.

C.11 Sample calculation for protection of inner core(s) of coaxial cable

Consider the case of 20 m of shielded cable with the shield bonded at both ends. 10% of the lightning current flows through the cable and the cable shield has a resistance of 5 Ω/km .

For a 200 kA strike, the voltage produced is given by:

$$\begin{aligned} V &= R \times I \\ &= 0.1 \times 200 \times 10^3 \times 0.1 \\ &= 2000 \text{ V} \end{aligned}$$

For a 20 kA strike, the voltage produced is given by:

$$\begin{aligned} V &= R \times I \\ &= 0.1 \times 20 \times 10^3 \times 0.1 \\ &= 200 \text{ V} \end{aligned}$$

These resistive voltages are coupled fully into the internal wires.

If the cable were placed on a bonded cable tray, there would be a preference for current to flow in the tray. In typical cases, only 10 % of current would flow in the coaxial cable.

For a 200 kA strike, the voltage produced is given by:

$$\begin{aligned} V &= R \times I \\ &= 0.1 \times 200 \times 10^3 \times 0.1 \times 0.1 \\ &= 200 \text{ V} \end{aligned}$$

For a 20 kA strike, the voltage produced is given by:

$$\begin{aligned} V &= R \times I \\ &= 0.1 \times 20 \times 10^3 \times 0.1 \times 0.1 \\ &= 20 \text{ V} \end{aligned}$$

Depending on the use of the cable, damage may or may not occur, as in the following examples.

- If the cable was the feed from a thermionic valve radio transmitter to an aerial, a voltage greater than 2 000 V is unlikely to cause damage.
- If the cable was a part of a robust computer network, a voltage of 2 000 V would probably cause damage; voltages of 200 V or 20 V probably would not.
- If the cable carried an RS 232 (V 24) link, only the 20 V value would be acceptable. 2 000 V and 200 V would cause damage.

C.12 Sample calculation of induced voltage in wiring

Figure C.14 shows the relative values of currents in individual cables alongside or inside a process vessel or similar object. As can be seen, the currents are a strong function of position relative to the tower and other metal components. Values of induced voltage appropriate to the various positions identified may be calculated as follows.

- For a cable protected by a cable tray, assuming a cable screen current of 400 A, a tower of 30 m height and a cable screen resistance of 10 m Ω/m :

$$\begin{aligned} \text{Total resistance} &= 30 \times 10 \times 10^{-3} \\ &= 0.3 \Omega \end{aligned}$$

The induced common mode voltage is given by:

$$\begin{aligned} V &= R \times I \\ &= 0.3 \times 400 \\ &= 120 \text{ V} \end{aligned}$$

b) For a cable protected by a cable tray and pipes and assuming a current of 100 A:

The induced common mode voltage is given by:

$$\begin{aligned} V &= R \times I \\ &= 0.3 \times 100 \\ &= 30 \text{ V} \end{aligned}$$

c) For a cable inside the vessel, or inside a metal cylinder, the induced voltage would be negligible.

C.13 Surge protection devices, location categories and testing

C.13.1 Location categories

C.13.1.1 General

As a mains transient, represented by a 1.2/50 μs voltage pulse, propagates through a building, the magnitude of current it can source diminishes (due to the inductance of the mains cables). This effect is represented by the three location categories C, B and A. Category C is on the supply side of an incoming power board, category B represents the mains distribution system and category A represents the load side of a socket outlet.

Within a given location category, the severity levels of the transients encountered will increase as risk of a transient occurring increases. This can be represented by the system exposure level, which in turn can be derived from the risk assessment.

C.13.1.2 Data/signal cables

All data/signal line surge protection devices fall into location category C irrespective of location as the slower 10/700 μs voltage pulse used to represent a data line transient is not attenuated by a cable to the same extent as a mains transient.

C.13.1.3 Mains power

C.13.1.3.1 Location category C

Surge protection devices installed in the following locations fall into category C:

- on the supply side of incoming power distribution boards/switchgear (i.e. boards that bring power into a building, from the supply authority, HV/LV transformer or another building);
- on the load side of outgoing power distribution boards/switchgear (i.e. boards that take power to other buildings, external lights, pumps etc.);
- on the outside of a building.

C.13.1.3.2 Location category B

Protection devices installed in the following locations fall into category B:

- on a power distribution system, between the load side of the incoming mains power distribution board/switchgear and supply side of a socket outlet/fused connection unit;
- within apparatus that is not fed via a socket outlet/fused connection unit;
- load side of socket outlets/fused connection units located less than a 20 m cable run from category C.

C.13.1.3.3 Location category A

Protection devices installed on the load side of socket outlets/fused connection units and more than a 20 m cable run from category C, fall into category A.

NOTE Category A does not appear in small buildings where socket outlets are all less than 20 m from category C.

C.13.2 Magnitude of representative wave forms for testing mains surge protection devices

An appropriate test level is selected from Tables C.8 to C.10 for the location category and level of system exposure of the surge protection device under test.

Table C.8 — Location category A (mains)

System exposure	Peak voltage kV	Peak current A
Low	2	166.7
Medium	4	333.3
High	6	500

Table C.9 — Location category B (mains)

System exposure	Peak voltage kV	Peak current kA
Low	2	1
Medium	4	2
High	6	3

Table C.10 — Location category C (mains)

System exposure	Peak voltage kV	Peak current kA
Low	6	3
Medium	10	5
High	20	10

C.13.3 Testing mains surge protection devices

The test generator for categories C and B is a combination wave generator, capable of producing 1.2/50 μs voltage and 8/20 μs current waveform (see C.13.7). For category A, a non-inductive output resistor is added to limit current to the appropriate value. The short circuit current waveform will no longer be 8/20 μs .

A test method for surge protection devices is given in section 24 of UL 1449:1985 [5].

C.13.4 Magnitude of representative waveform for testing data line barriers

An appropriate test level is selected from Table C.11 for the exposure of the surge protection device selected.

C.13.5 Testing data line surge protection devices

C.13.5.1 High current impulse life test

A combination wave generator described in 14.3 is suitable for these tests.

The test method is given in 5.6 of ITU-T K.12 [6].

C.13.5.2 Let-through voltage tests

A suitable test generator is given in Figure 1 of CCITT IX K17:1984 [7].

A test method is given in paragraph 24.3 of UL 1449:1985 [5].

C.13.6 Information to be provided by manufacturers of surge protection devices

C.13.6.1 Information on transient performance

Manufacturers of surge protection devices should be requested to provide the following information on transient performance.

- a) *Let-through voltage*, e.g. 850 V, all modes, test 6 kV, 1.2/50 μ s, 3 kA 8/20 μ s.

NOTE 1 This is a test value for the complete surge protection device, not a theoretical value.

NOTE 2 The let-through voltage of a surge protection device takes into account the response time of the device i.e. a slow response time will result in a high let-through voltage. Lightning transients are not particularly fast; response time is more important for faster transients e.g. NEMP etc. The response time of a parallel-connected protector is often overshadowed by inductive voltage drops on the connecting leads.

- b) *Mode of protection*, e.g. line-to-earth, line-to-neutral, neutral-to-earth for mains or line-to-line or line(s)-to-earth for data.

- c) *Maximum surge current*, e.g. 20 000 A, 8/20 μ s.

NOTE 1 This is a test value for the complete surge protection device, not a theoretical value.

NOTE 2 The energy handling of a protection device is implied by the maximum surge current. The use of energy ratings as an indicator of the comparative merit of differing designs can be misleading, as the energy deposited in a protector by a transient current source depends on the suppression level (let-through voltage). Therefore a lower energy rating does not necessarily mean a lower capability of survival.

- d) *System impairment*. If the surge protection device impairs the operation of the system after a transient has passed, full details of any effect should be given. [See C.13.6.2, item e)].

A gas-discharge tube used as a surge protection device connected across a mains power supply can short circuit the supply when it operates. A large mains current will flow through the tube which may cause disruption of the power supply and/or destruction of the tube.

C.13.6.2 Information on passive state performance

Manufacturers of surge protection devices should be requested to provide the following information on passive state performance:

- nominal operating voltage;
- maximum operating voltage;
- leakage current;
- current rating;
- system impairments.

Any factor that may affect operation of the system should be quoted, e.g.:

- in-line impedance;
- shunt capacitance;
- bandwidth;
- voltage standing wave ratio (VSWR);
- reflection coefficient.

C.13.7 Combination wave test generator

C.13.7.1 General

The simplified circuit diagram of the generator is shown in Figure C.18.

The values of the different elements R_{s1} , R_{s2} , R_m , L_T and C_c are defined so that the generator delivers a 1.2/50 μ s voltage surge (at open circuit conditions) and a 8/20 μ s current surge into a short circuit, i.e. the generator has an effective output impedance of 2 Ω .

For convenience, an effective output impedance is defined for a surge generator by calculating the ratio of peak open circuit output voltage and peak short circuit current. Such a generator with a 1.2/50 μ s open circuit voltage waveshape and a 8/20 μ s short circuit current waveshape is referred to as a Combination Wave Generator (CWG).

NOTE Switchover from voltage to current happens as a function of the input impedance during surges to equipment due either to proper operation of the installed protection devices, or to flashover or component breakdown if the protection devices are absent or inoperative. Therefore the 1.2/50 μ s voltage and the 8/20 μ s current waves need to be available from the same test generator output as instantaneously required by the load.

Table C.11 — Location category C (data lines)

System exposure	High impulse current test kA	Let-through voltage test	
		Voltage kV	Current A
Low	2.5	1.5	37.5
Medium	5	3	75
High	10	5	125

C.13.7.2 Characteristics and performance of the combination wave generator

Open circuit output voltage:	At least as low as 0.5 kV to at least as high as 6.0 kV for category B tests and 20 kV for category C tests.
Waveshape of the voltage surge:	See Figure C.19 and Table C.12.
Short circuit output current:	At least as low as 0.25 kA to at least as high as 3.0 kA for category B tests and 10 kA for category C tests.
Waveshape of the current surge:	See Figure C.20 and Table C.12.
Polarity:	Positive/negative.
Phase shifting:	In a range between 0° to 360° versus the a.c. line phase angle.
Repetition rate:	At least 1 per min.

NOTE A generator with a floating output is preferred.

Table C.12 — Definitions of the waveshape parameters 1.2/50 μ s

Definitions	In accordance with BS 923-2		In accordance with BS 5698-1	
	Front time μ s	Time to half value μ s	Rise time (10 % to 90%) μ s	Duration (50 % to 50 %) μ s
Open circuit voltage	1.2	50	1	50
Short circuit current	8	20	6.4	16

NOTE The waveforms 1.2/50 μ s and 8/20 μ s have been generally defined in accordance with BS 923-2, as shown in Figures C.19 and C.20. More recent recommendations are based on waveform definitions in accordance with BS 5698-1 as shown in Table C.12. Both of these definitions are valid for this standard and refer to a single generator.

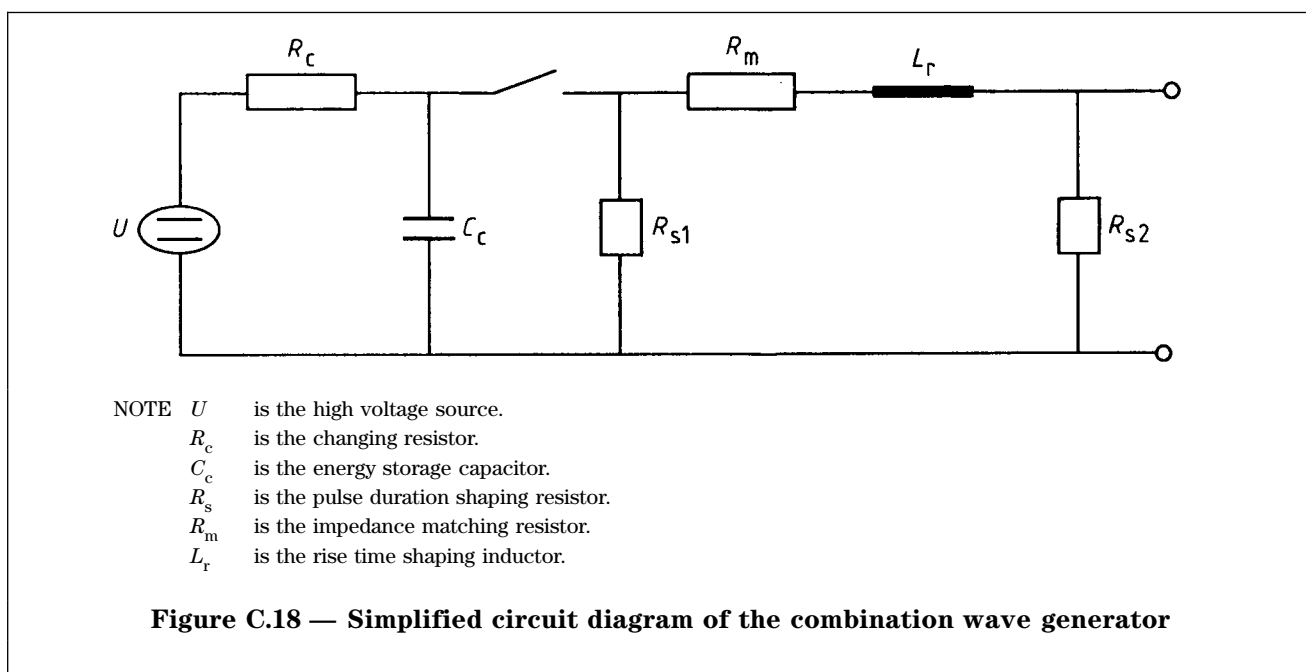
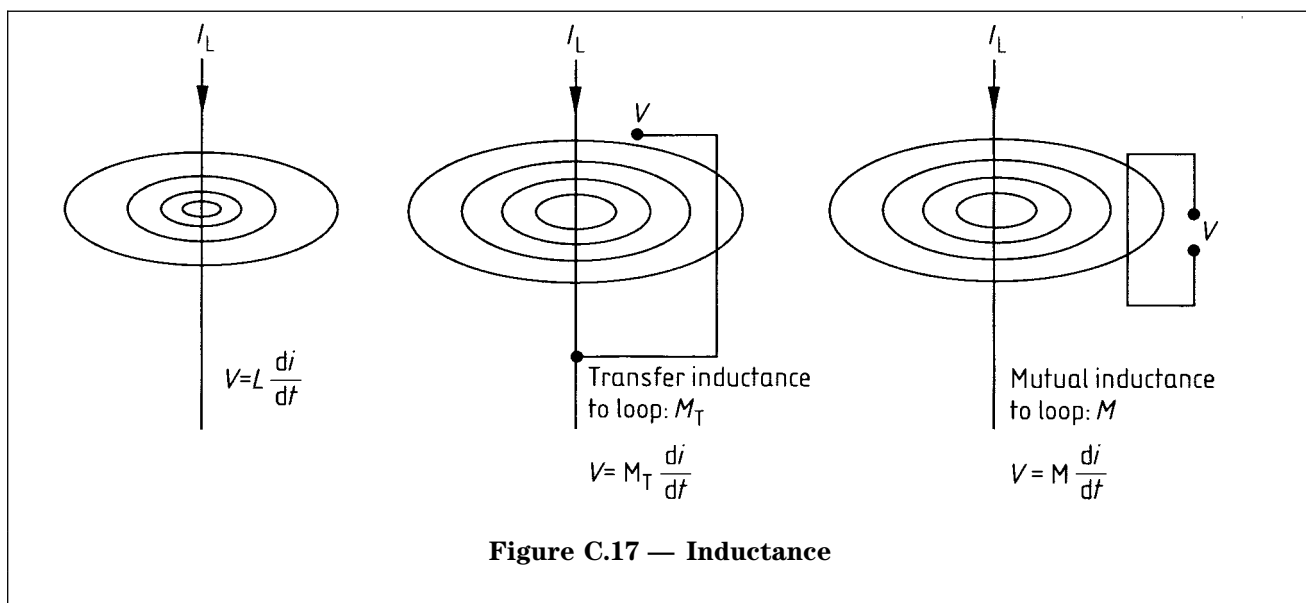

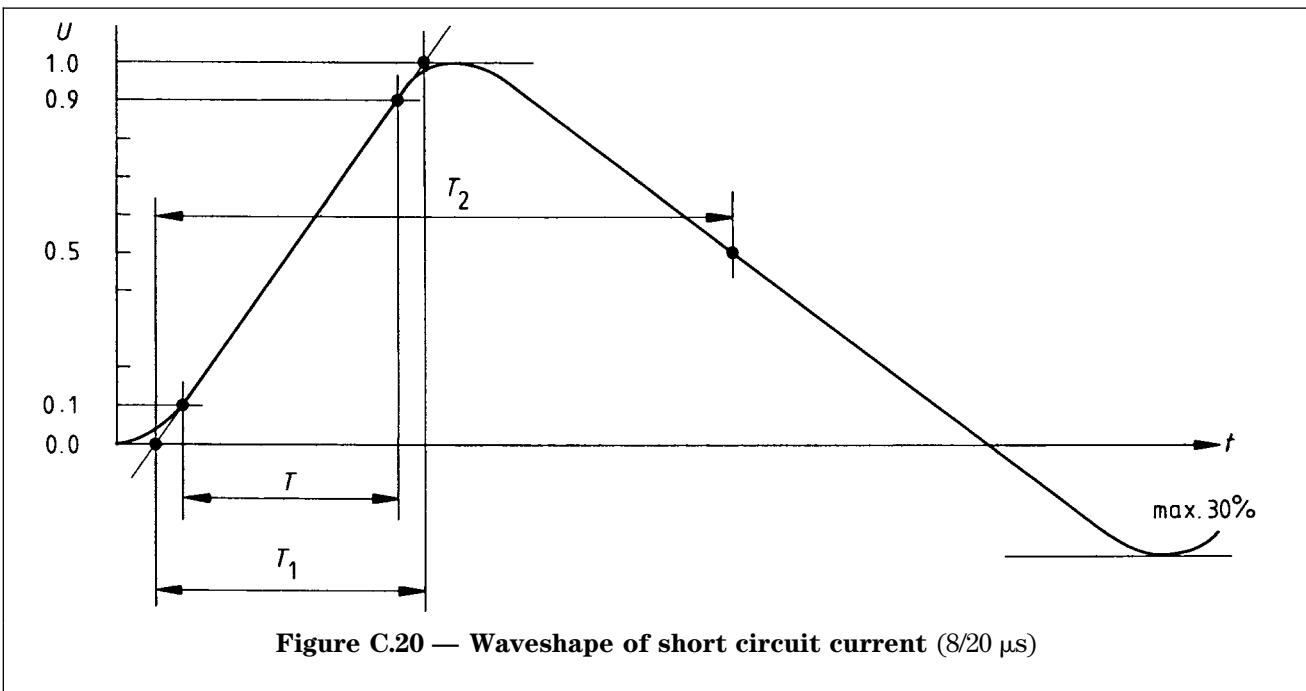
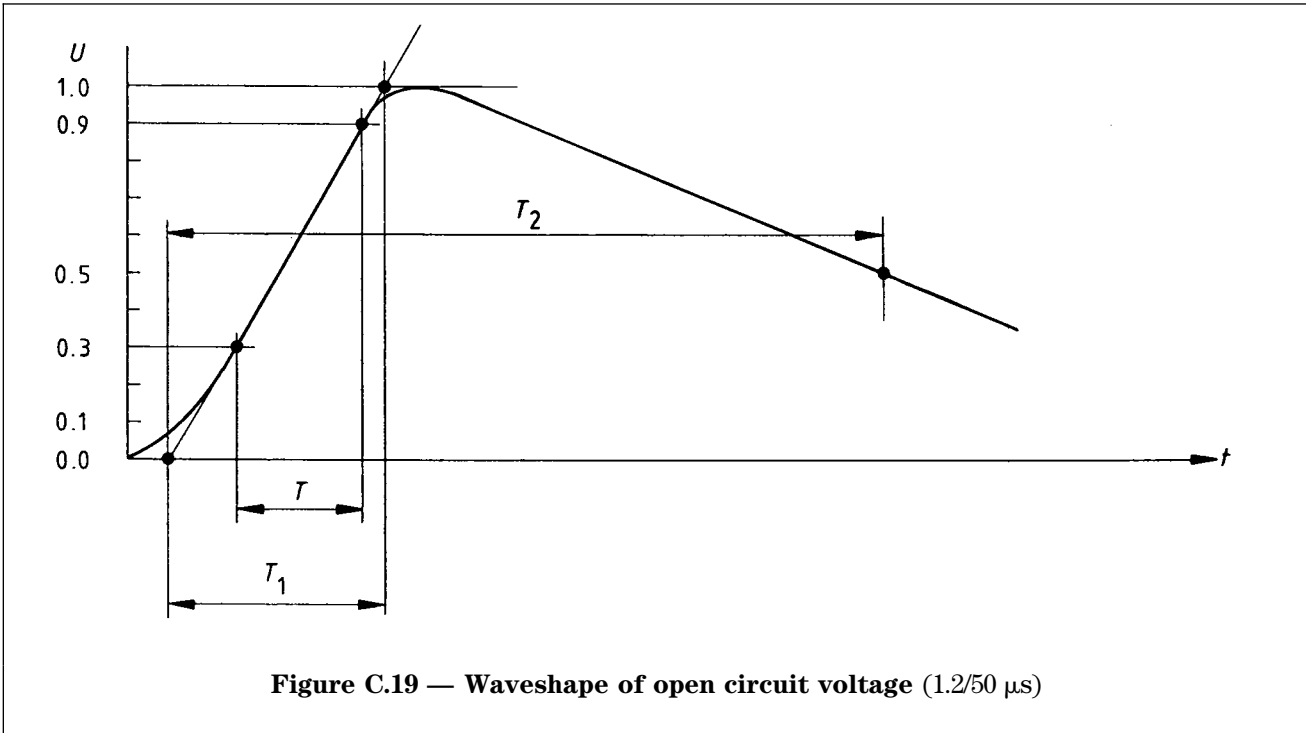

Bibliography

- BS 215-1, *Specification for aluminium conductors and aluminium conductors, steel-reinforced for overhead power transmission — Part 1: Aluminium stranded conductors.*
- BS 215-2, *Specification for aluminium conductors and aluminium conductors, steel-reinforced for overhead power transmission — Part 2: Aluminium conductors, steel-reinforced.*
- BS 302, *Stranded steel wire ropes.*
- BS 970-1, *Specification for wrought steels for mechanical and allied engineering purposes — Part 1: General inspection and testing procedures and specific requirements for carbon, carbon manganese, alloy and stainless steels.*
- BS 1400, *Specification for copper alloy ingots and copper alloy and high conductivity copper castings.*
- BS 1432, *Specification for copper for electrical purposes: high conductivity copper rectangular conductors with drawn or rolled edges.*
- BS 1433, *Specification for copper for electrical purposes — Rod and bar.*
- BS 1449-1, *Steel plate, sheet and strip — Part 1: Carbon and carbon-manganese plate, sheet and strip.*
- BS 1449-2, *Steel plate, sheet and strip — Part 2: Specification for stainless and heat-resisting steel plate, sheet and strip.*
- BS 1452, *Specification for flake graphite cast iron.*
- BS 1470, *Specification for wrought aluminium and aluminium alloys for general engineering purposes — Plate, sheet and strip.*
- BS 1471, *Specification for wrought aluminium and aluminium alloys for general engineering purposes — Drawn tube.*
- BS 1472, *Specification for wrought aluminium and aluminium alloys for general engineering purposes — Forging stock and forging.*
- BS 1473, *Specification for wrought aluminium and aluminium alloys for general engineering purposes — Rivet, bolt and screw stock.*
- BS 1474, *Specification for wrought aluminium and aluminium alloys for general engineering purposes — Bars, extruded round tubes and sections.*
- BS 2571, *Specification for general-purposes flexible PVC compounds for moulding and extrusion.*
- BS 2755, *Specification for copper and copper-cadmium stranded conductors for overhead electric traction systems.*
- BS 2870, *Specification for rolled copper and copper alloys: sheet, strip and foil.*
- BS 2871, *Specification for copper and copper alloys. Tubes — Part 3: Tubes for heat exchangers.*
- BS 2872, *Specification for copper and copper alloy forging stock and forgings.*
- BS 2873, *Specification for copper and copper alloys. Wire.*
- BS 2874, *Specification for copper and copper alloy rods and sections (other than forging stock).*
- BS 2897, *Specification for wrought aluminium for electrical purposes. Strip with drawn or rolled edges.*
- BS 2898, *Specification for wrought aluminium and aluminium alloys for electrical purposes. Bars, extruded round tube and sections.*
- BS 3111-1, *Steel for cold forged fasteners and similar components — Part 1: Specification for carbon and low alloy steel wire.*
- BS 3111-2, *Steel for cold forged fasteners and similar components — Part 2: Stainless steel.*
- BS 3242, *Specification for aluminium alloy stranded conductors for overhead power transmission.*
- BS 3988, *Specification for wrought aluminium for electrical purposes. Solid conductors for insulated cables.*
- BS 4485-4, *Water cooling towers — Part 4: Code of practice for structural design and construction.*
- BS 5493, *Code of practice for protective coating of iron and steel structures against corrosion.*
- BS 5655, *Lifts and service lifts.*
- BS 5698-1, *Guide to pulse techniques and apparatus — Part 1: Pulse terms and definitions.*
- BS 6360, *Specification for conductors in insulated cables and cords.*
- BS 6681, *Specification for malleable cast iron.*
- BS 6746, *Specification for PVC insulation and sheath of electric cables.*
- BS EN 10025, *Specification for hot rolled products of non-alloy structural steels and their technical delivery conditions.*

DD 24, *Recommendations for methods of protection against corrosion on light section steel used in building.*
PD 6484, *Commentary on corrosion at bimetallic contacts and its alleviation.*

[1] ANDERSON R.B., and ERIKSSON, A.J., (CIGRE), *Lightning Parameters for Engineering Application.* *Electra*, 1980, **69**, 65-102.

[2] Royal Commission on Environmental Pollution, Chairman Sir Brian Flowers, Sixth Report, *Nuclear power and the Environment* (Cmnd 6618).

[3] ECMA 97¹⁾, *Local area network safety requirements.*

[4] CCITT Publication¹⁾, *The protection of telecommunication lines and equipment against lightning discharges.*

[5] UL 1449:1985¹⁾, *Transient voltage surge suppressor.*

[6] ITU-T K.12:1995¹⁾.

[7] CCITT Recommendation K17:1984¹⁾, *Protection against interference*; Blue book, Volume IX.

¹⁾ Copies of ITU-T(CCITT) publications, ECMA and UL Standards are available from BSI Customer Services.

BSI — British Standards Institution

BSI is the independent national body responsible for preparing British Standards. It presents the UK view on standards in Europe and at the international level. It is incorporated by Royal Charter.

Revisions

British Standards are updated by amendment or revision. Users of British Standards should make sure that they possess the latest amendments or editions.

It is the constant aim of BSI to improve the quality of our products and services. We would be grateful if anyone finding an inaccuracy or ambiguity while using this British Standard would inform the Secretary of the technical committee responsible, the identity of which can be found on the inside front cover. Tel: 020 8996 9000. Fax: 020 8996 7400.

BSI offers members an individual updating service called PLUS which ensures that subscribers automatically receive the latest editions of standards.

Buying standards

Orders for all BSI, international and foreign standards publications should be addressed to Customer Services. Tel: 020 8996 9001. Fax: 020 8996 7001.

In response to orders for international standards, it is BSI policy to supply the BSI implementation of those that have been published as British Standards, unless otherwise requested.

Information on standards

BSI provides a wide range of information on national, European and international standards through its Library and its Technical Help to Exporters Service. Various BSI electronic information services are also available which give details on all its products and services. Contact the Information Centre. Tel: 020 8996 7111. Fax: 020 8996 7048.

Subscribing members of BSI are kept up to date with standards developments and receive substantial discounts on the purchase price of standards. For details of these and other benefits contact Membership Administration. Tel: 020 8996 7002. Fax: 020 8996 7001.

Copyright

Copyright subsists in all BSI publications. BSI also holds the copyright, in the UK, of the publications of the international standardization bodies. Except as permitted under the Copyright, Designs and Patents Act 1988 no extract may be reproduced, stored in a retrieval system or transmitted in any form or by any means – electronic, photocopying, recording or otherwise – without prior written permission from BSI.

This does not preclude the free use, in the course of implementing the standard, of necessary details such as symbols, and size, type or grade designations. If these details are to be used for any other purpose than implementation then the prior written permission of BSI must be obtained.

If permission is granted, the terms may include royalty payments or a licensing agreement. Details and advice can be obtained from the Copyright Manager. Tel: 020 8996 7070.