

BS 6387:2013



BSI Standards Publication

Test method for resistance to fire of cables required to maintain circuit integrity under fire conditions

bsi.

...making excellence a habit.™

Publishing and copyright information

The BSI copyright notice displayed in this document indicates when the document was last issued.

© The British Standards Institution 2013

Published by BSI Standards Limited 2013

ISBN 978 0 580 81046 6

ICS 13.220.99; 29.060.20

The following BSI references relate to the work on this standard:

Committee reference GEL/20/18

Draft for comment 13/30273419 DC

Publication history

First published September 1983

Second edition January 1994

Third (present) edition December 2013

Amendments issued since publication

Date	Text affected
-------------	----------------------

Contents

Foreword *ii*

1	Scope	1
2	Normative references	1
3	Terms and definitions	1
4	Categorization of cables	1
5	Test chamber	2
6	Protocol C for resistance to fire alone	2
7	Protocol W for resistance to fire with water	5
8	Protocol Z for resistance to fire with mechanical shock	10

Bibliography 15

List of figures

Figure 1	– Cable supporting arrangement for test for fire resistance alone	3
Figure 2	– Circuit diagram	4
Figure 3	– Method of supporting cable for test of resistance to fire with water	5
Figure 4	– Example of supporting frame for test for resistance to fire with water	6
Figure 5	– End elevation of supporting frame for test for resistance to fire with water	7
Figure 6	– Burner face for test	8
Figure 7	– Example of sprinkler head for test for resistance to fire with water	9
Figure 8	– Rig for test for resistance to fire with mechanical shock	11
Figure 9	– Typical rubber bush for fastening board for test for resistance to fire with mechanical shock	12
Figure 10	– Cable mounting for test for resistance to fire with mechanical shock	13

Summary of pages

This document comprises a front cover, an inside front cover, pages i to iv, pages 1 to 16, an inside back cover and a back cover.

Foreword

Publishing information

This British Standard is published by BSI Standards Limited, under licence from The British Standards Institution, and came into effect on 31 December 2013. It was prepared by Subcommittee GEL/20/18, *Fire testing*, under the authority of Technical Committee GEL/20, *Electric cables*. A list of organizations represented on these committees can be obtained on request to their secretary.

Supersession

This British Standard supersedes BS 6387:1994, which is withdrawn.

Information about this document

This is a full revision of the standard, which now gives only a test method for fire resistance characteristics of cables. Physical and electrical tests and their relevant requirements are now given in the appropriate product standards. Other test methods for the fire resistance of cables have been developed since the previous revision of BS 6387. These include BS 8434 and BS 8491, catering for specific applications, installations and end-user markets.

The test method given in this British Standard consists of three component protocols, designated C, W and Z. These are technically unchanged from the previous edition. Previous editions of BS 6387 have included categories based on other protocols (A, B, S, X and Y). These are now regarded as obsolete.

When separate test pieces from the same sample of cable are tested to each of these three protocols, these together comprise the full test. When the requirements of each one of the protocols are met, the cable may be designated as "category CWZ". In detail:

- a) Protocol C subjects the cable under test to a flame via direct impingement corresponding to a temperature attack of $950\text{ °C} \pm 40\text{ °C}$.
- b) Protocol W subjects the cable under test to a flame via direct impingement corresponding to a temperature attack of $650\text{ °C} \pm 40\text{ °C}$ with direct application of water simulating a sprinkler system.
- c) Protocol Z subjects the cable under test to a flame via direct impingement corresponding to a temperature attack of $950\text{ °C} \pm 40\text{ °C}$ with indirect application of mechanical shock.

Product standards might refer to only one of the protocols C or W or Z in, respectively, Clauses 6, 7 or 8 but, in such cases, may not use the designation "Category CWZ".

It is emphasized that fire tests do not assess a fire hazard, nor can the results of fire tests alone guarantee safety. They only provide information to assist in the assessment of the suitability of a cable for a given application.

Hazard warnings

WARNING. This British Standard calls for the use of substances and/or procedures that can be injurious to health if adequate precautions are not taken. It refers only to technical suitability and does not absolve the user from legal obligations relating to health and safety at any stage. The test methods given in this British Standard might involve the use of dangerous voltages and temperatures. Suitable precautions should be taken against the risks of shock, burning, fire and explosion that might be involved, and against any noxious fumes that might be produced.

Use of this document

It has been assumed in the preparation of this British Standard that the execution of its provisions will be entrusted to appropriately qualified and experienced people, for whose use it has been produced.

Presentational conventions

The provisions of this standard are presented in roman (i.e. upright) type. Its methods are expressed as a set of instructions, a description, or in sentences in which the principal auxiliary verb is "shall".

Commentary, explanation and general informative material is presented in smaller italic type, and does not constitute a normative element.

Contractual and legal considerations

This publication does not purport to include all the necessary provisions of a contract. Users are responsible for its correct application.

Compliance with a British Standard cannot confer immunity from legal obligations.

1 Scope

This British Standard gives a test method for resistance to fire of cables required to maintain circuit integrity under fire conditions. It is applicable to cables of rated voltage not exceeding 600/1 000 V and of overall diameter less than or equal to 20 mm.

The test given in this British Standard is applicable to cables having two or more insulated conductors, whether or not the cables incorporate other metallic elements such as armour, screen or circuit protective conductor. The test is also applicable to cables having one insulated conductor provided that the cable incorporates at least one other metallic element. The test is not applicable to cables having one insulated conductor but no other metallic element.

2 Normative references

The following documents, in whole or in part, are normatively referenced in this document and are indispensable for its application. For dated references, only the edition cited applies. For undated references, the latest edition of the referenced document (including any amendments) applies.

BS EN 60584-1, *Thermocouples – Part 1: Reference tables (IEC 60584-1)*

BS EN 60695-4, *Fire hazard testing – Part 4: Terminology concerning fire tests for electrotechnical products*

BS EN ISO 13943, *Fire safety – Vocabulary*

IEC 60269-3:2010, *Low-voltage fuses – Part 3: Supplementary requirements for fuses for use by unskilled persons (fuses mainly for household and similar applications) – Examples of standardized systems of fuses A to F*

3 Terms and definitions

For the purposes of this British Standard, the terms and definitions given in BS EN ISO 13943, BS EN 60695-4 and the following apply.

3.1 rated voltage, U_0

nominal power-frequency voltage between conductor(s) and earth, for which the cable is suitable

3.2 rated voltage, U

nominal power-frequency voltage between phase conductors for which the cable is suitable

4 Categorization of cables

Cables shall be tested to each of the three protocols, namely:

- resistance to fire alone, Protocol C (Clause 6);
- resistance to fire with water, Protocol W (Clause 7);
- resistance to fire with mechanical shock, Protocol Z (Clause 8).

Cables passing all three protocols shall be designated Category CWZ.

NOTE 1 Product standards might refer to only one of the protocols in Clauses 6, 7 or 8 but in such cases, they may not use the designation "Category CWZ".

NOTE 2 Previous editions of this British Standard have included categories based on other protocols (A, B, S, X and Y). These are now regarded as obsolete.

5 Test chamber

Each test shall be carried out in a chamber with facilities for disposing of any noxious gases resulting from burning. Sufficient ventilation shall be available to sustain the burner flame for the duration of the test.

The locations of any air inlets and exhaust chimney shall be such that the burner flame remains stable during each test protocol. For each test protocol, the same ventilation and shielding conditions as used for the verification of the source of heat shall be used.

The temperature in the chamber shall be between 10 °C and 40 °C at the start of each test.

6 Protocol C for resistance to fire alone

6.1 Apparatus

6.1.1 Test rig, comprising a cable supporting system (6.1.2), a circuit continuity checking and voltage withstand arrangement and fuses (6.1.3 and 6.1.4) and a source of heat (6.1.5).

6.1.2 Cable supporting system, in which the cable sample under test is held horizontally by means of a suitable clamp at one end of the sheathed or protected portion and a support at the other end. The middle portion of the cable is supported by two metal rings placed approximately 300 mm apart and these as well as any other metal parts of the supporting apparatus are earthed. The cable supporting arrangement is shown in Figure 1. For unarmoured cables less than 10 mm in diameter, or for other cables where significant movement of the cable could occur during the test, the cable is supported by three additional metal supporting rings, each placed approximately 150 mm from the other two rings.

6.1.3 Circuit continuity checking and voltage withstand arrangement, comprising a three-phase star-connected transformer or three single-phase transformers (or one single-phase transformer if testing a single-core cable) of sufficient capacity to maintain the test voltage up to the maximum leakage current allowable, i.e. up to 2 A, and at the opposite end of the cable one or more lamps (with ballast resistor if necessary) connected to each core with a power rating such that each core carries a current of approximately 0.25 A at the rated voltage of the cable.

6.1.4 Fuses, IEC 60269-3:2010 Fuse system A–D, Type DII, 2A (Pink) or circuit breakers with equivalent characteristics. In case of dispute the use of fuses shall be the reference method.

6.1.5 Source of heat, comprising a tube-type gas burner with a burner face length of 610 mm \pm 10 mm, which produces a line of closely spaced flames using propane with a forced air supply.

The temperature of the flames from the burner shall be set using a 1.5 mm Type K thermocouple conforming to BS EN 60584-1, using the following procedure. Insert the thermocouple into the flame position at the end of the burner closest to the gas inlet with the thermocouple parallel to the burner and situated 75 mm above it.

With the thermocouple in position, light the burner and adjust the gas and air supplies until a flame temperature of 950 °C \pm 40 °C is steadily registered for at least 5 min. Record the values of gas and air flow and switch the burner off.

Figure 1 Cable supporting arrangement for test for fire resistance alone

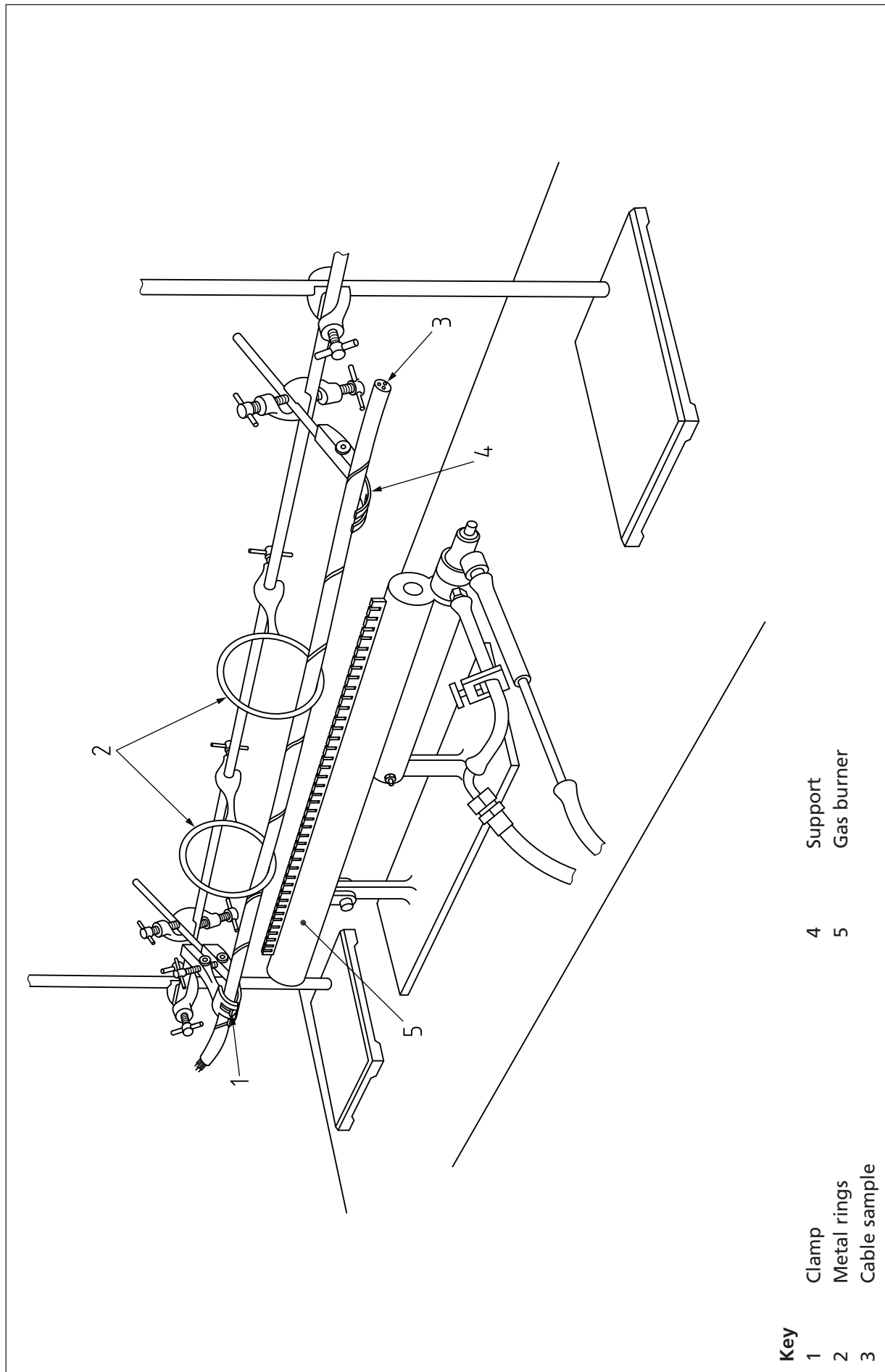

- Key**
- 1 Clamp
 - 2 Metal rings
 - 3 Cable sample
 - 4 Support
 - 5 Gas burner

6.2 Cable sample

The sample to be tested shall be a piece of the completed cable not less than 1 200 mm long, with approximately 100 mm of the sheath and outer coverings removed from each end. At the ends of the cable the conductors shall be prepared for electrical connections in accordance with the manufacturer's recommendations.

6.3 Procedure

Mount the cable sample in the clamp as described in 6.1.2 and adjust the metal supporting rings. Firmly clamp the cable at one end only.

Connect the transformer or transformers to the conductors at one end of the cable, excluding any conductor that is specifically identified as intended for use as a neutral or protective conductor, as shown in the circuit diagram in Figure 2. For single, twin or three conductor cables, connect each conductor to be connected to a separate phase of the transformer output with a 2 A fuse or equivalent circuit breaker (6.1.4) in each phase. For cables with more than three conductors to be connected divide the conductors into three groups, ensuring that adjacent conductors are in different groups, as far as possible. Connect the conductors in each group in parallel and connect each group to a separate phase of the transformer output, with a 2 A fuse or equivalent circuit breaker in each phase.

At the transformer end of the sample, earth the neutral conductor, the protective conductor and any drain wire and metallic layer. At the other end of the cable connect one terminal of a lamp as described in 6.1.3 to each phase conductor and the other terminal to earth.

Place the cable into position, so that it is parallel with the burner and the lower surface of the cable is 75 mm above the burner, as shown in Figure 1.

Figure 2 Circuit diagram

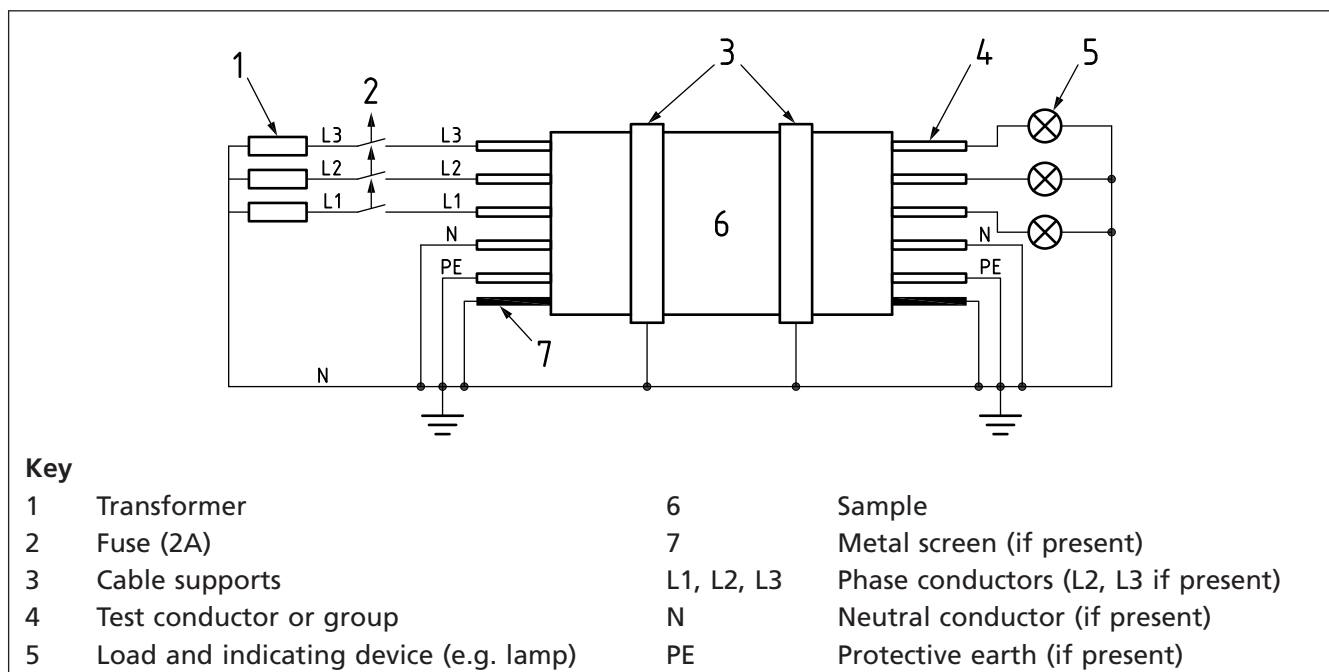

Light the burner using the gas and air settings obtained in 6.1.5, switch on the electricity supply and adjust the voltage between phases to the rated voltage U (or in the case of a single-core cable to the rated voltage to earth U_0). Continue the test for 3 h or until the cable fails, whichever happens first.

If necessary, periodically clean the burner surface throughout the test, to ensure the removal of fallen debris. If, for safety reasons, the test supply voltage needs to be switched off during the cleaning, extend the test time accordingly.

6.4 Assessment of test specimen performance

If, when the cable sample is tested, none of the fuses ruptures and none of the lamps is extinguished during the period of the test the cable shall be deemed to have passed the test.

If the sample fails to meet these criteria, two further samples shall be prepared and tested. If both these samples meet the criteria, the cable shall be deemed to have passed the test. If one or both samples fail to meet the criteria, the cable shall be deemed to have failed.

7 Protocol W for resistance to fire with water

7.1 Apparatus

7.1.1 Test rig, comprising a cable supporting system (7.1.2), a circuit continuity checking and voltage withstand arrangement and fuses (7.1.3 and 7.1.4), a source of heat (7.1.5) and a water spray (7.1.6).

7.1.2 Cable supporting system, in which the cable sample under test is attached to a metal support consisting of two strips of steel 25 mm \pm 1 mm wide, 1 150 mm \pm 25 mm long and 5.5 mm \pm 1 mm thick by means of copper clips as shown in Figure 3, the spacing of the clips being 200 mm \pm 10 mm. This assembly with the cable attached is supported in a test frame as shown in Figure 4 and Figure 5 and this frame is earthed.

NOTE Figure 4 shows an example of a supporting frame for the test. The exact construction is not critical as long as it conforms to the dimensional requirements of Figure 5.

Figure 3 Method of supporting cable for test of resistance to fire with water

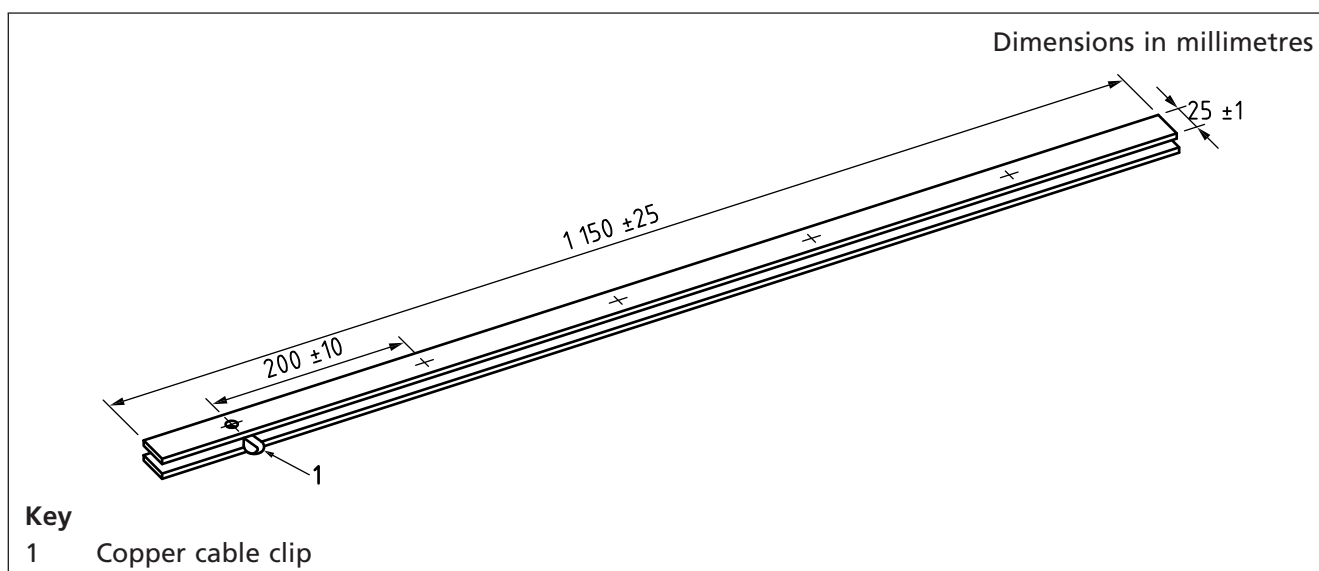

Figure 4 Example of supporting frame for test for resistance to fire with water

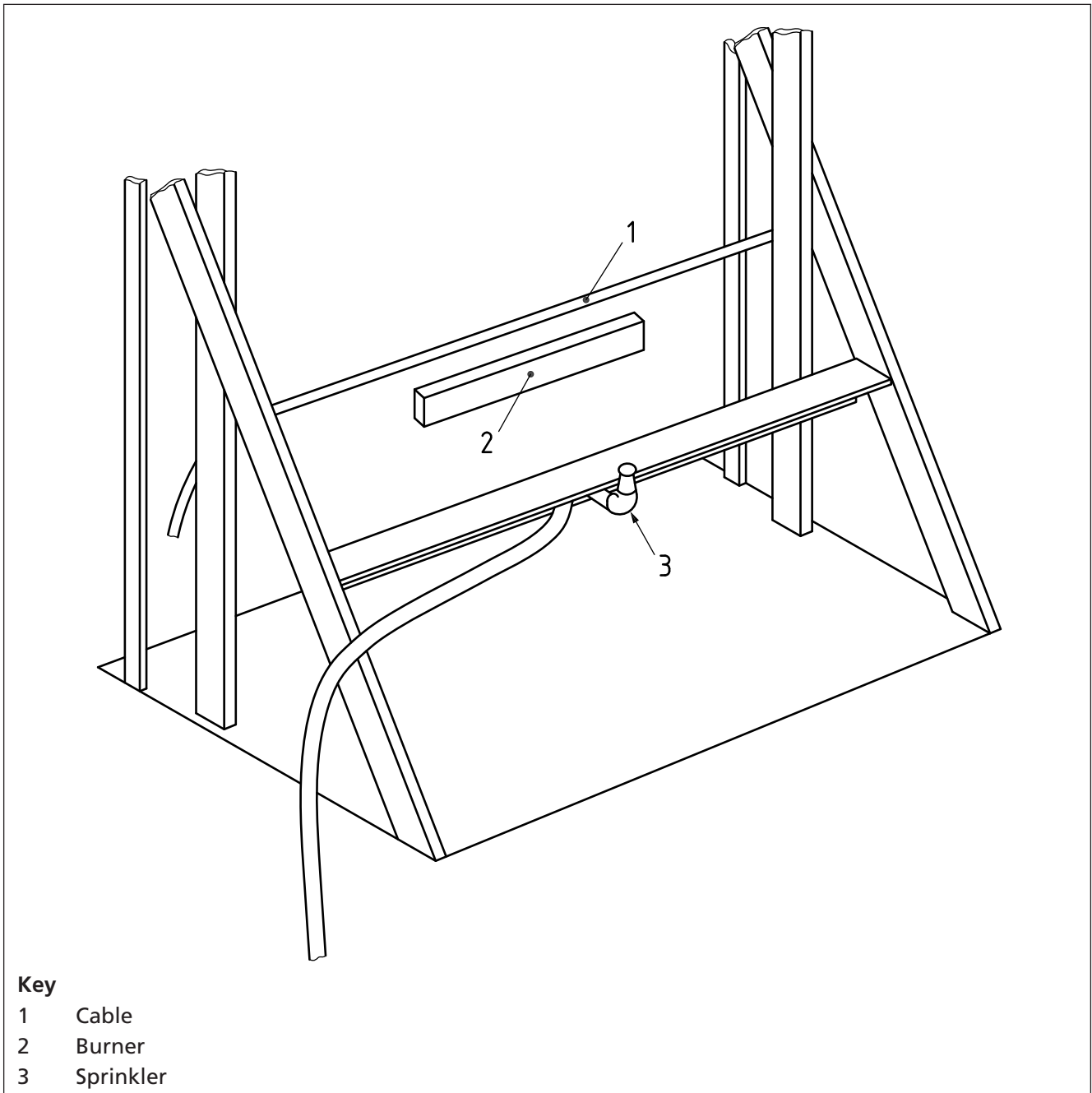
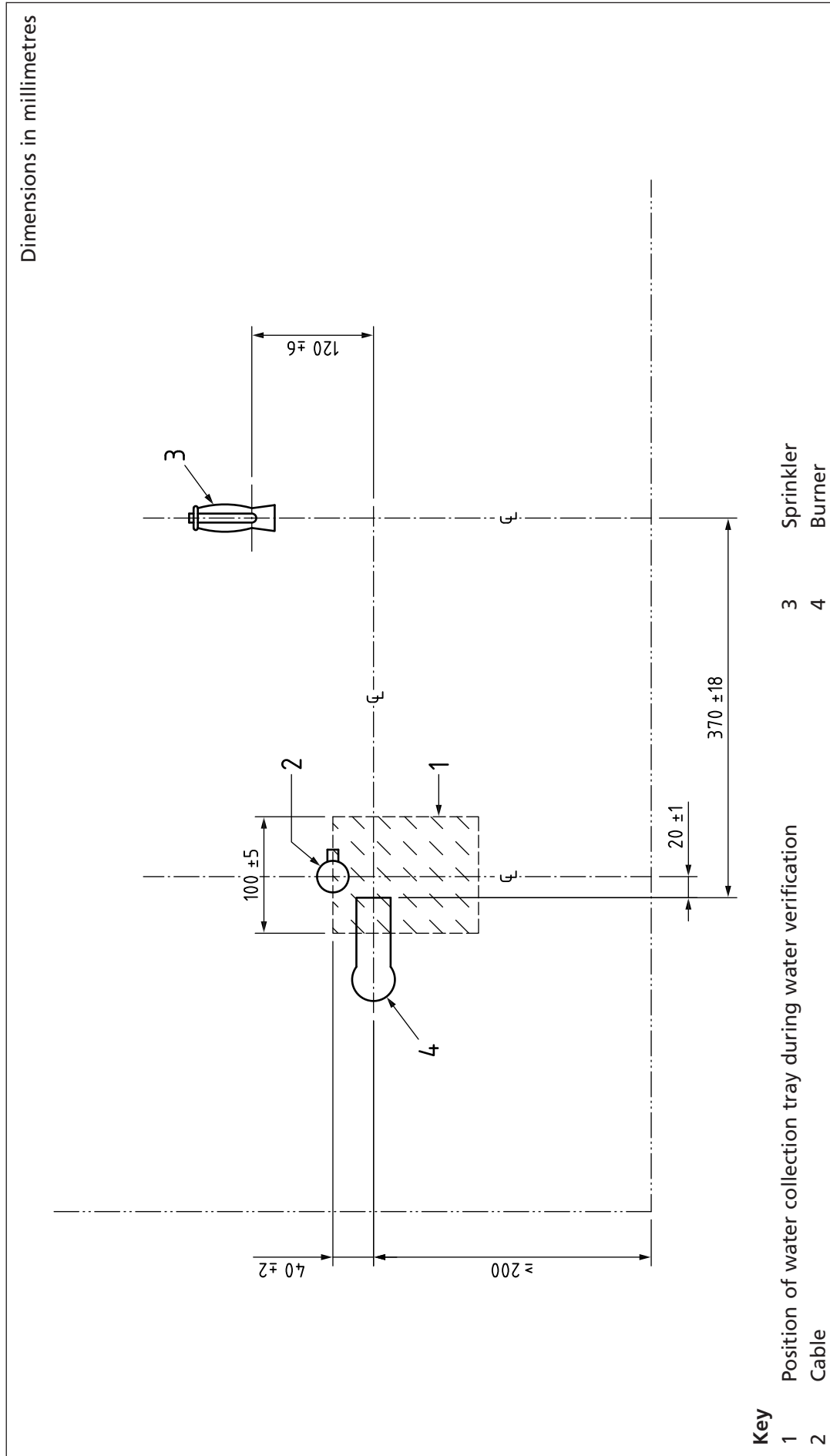

Figure 5 End elevation of supporting frame for test for resistance to fire with water



7.1.3 Circuit continuity checking and voltage withstand arrangement, comprising a three-phase star-connected transformer or three single-phase transformers (or one single-phase transformer if testing a single-core cable) of sufficient capacity to maintain the test voltage up to the maximum leakage current allowable, i.e. up to 2 A, and at the opposite end of the cable one or more lamps (with ballast resistor if necessary) connected to each core with a power rating such that each core carries a current of approximately 0.25 A at the rated voltage of the cable.

7.1.4 Fuses, IEC 60269-3:2010 Fuse system A–D, Type DII, 2A (Pink) or circuit breakers with equivalent characteristics. In case of dispute the use of fuses shall be the reference method.

7.1.5 Source of heat, comprising a ribbon-type propane gas burner with a nominal burner face length of 500 mm with a Venturi mixer (a centre-feed burner is recommended) and a nominal burner face width of 10 mm with three staggered rows of drilled holes, nominally 1.32 mm in diameter and drilled at 3.2 mm centres, as shown in Figure 6. Additionally a row of small holes milled on each side of the burner plate may be used, to serve as pilot holes for keeping the flame burning.

NOTE Additional guidance on suitable test equipment can be found in BS EN 50200:2006, Annex A.

The temperature of the flame from the burner shall be set using a 1.5 mm Type K thermocouple conforming to BS EN 60584-1, using the following procedure. Place the thermocouple into the position that the lower surface of the cable sample will occupy during the test. Light the burner and adjust the gas and air supplies until a flame temperature of $650\text{ }^{\circ}\text{C} \pm 40\text{ }^{\circ}\text{C}$ is steadily registered for at least 5 min. Record the values of gas and air flow and switch the burner off.

Figure 6 Burner face for test

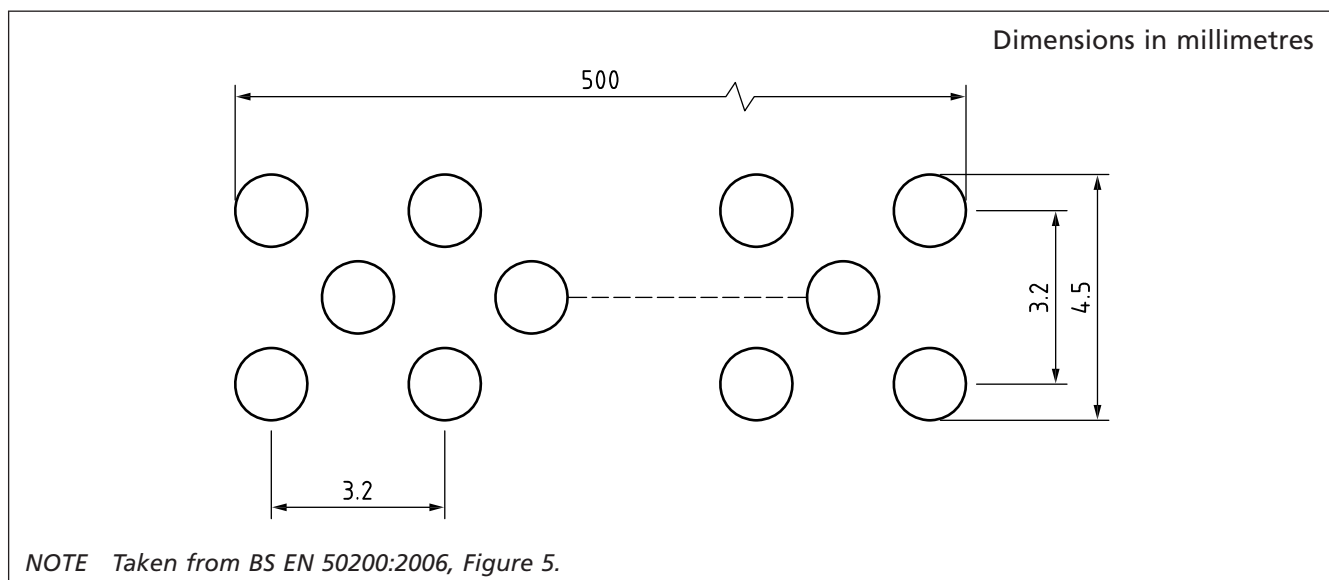

7.1.6 Water spray, in which a sprinkler head (see Figure 7) is fixed to the test frame, as shown in Figure 4 and Figure 5, and positioned centrally with respect to the burner assembly, supplying water at an approximately constant supply pressure sufficient to give a rate of water application in the vicinity of the cable sample between $0.25\text{ L/m}^2/\text{s}$ and $0.30\text{ L/m}^2/\text{s}$.

The rate shall be measured using a collection tray 100 mm \pm 5 mm wide and 400 mm \pm 5 mm long, and of sufficient depth to collect all the water. The tray shall be placed centrally, approximately in the position to be occupied by the cable, with its long axis placed along the cable axis (see Figure 5). The supply conditions used to meet the required rate of water application shall be recorded.

NOTE 1 Neither the burner nor the cable and its support are present during the verification of the water rate.

NOTE 2 A conventional pattern sprinkler as specified in BS EN 12259-1:1999, 3.7 may be used.

Figure 7 Example of sprinkler head for test for resistance to fire with water

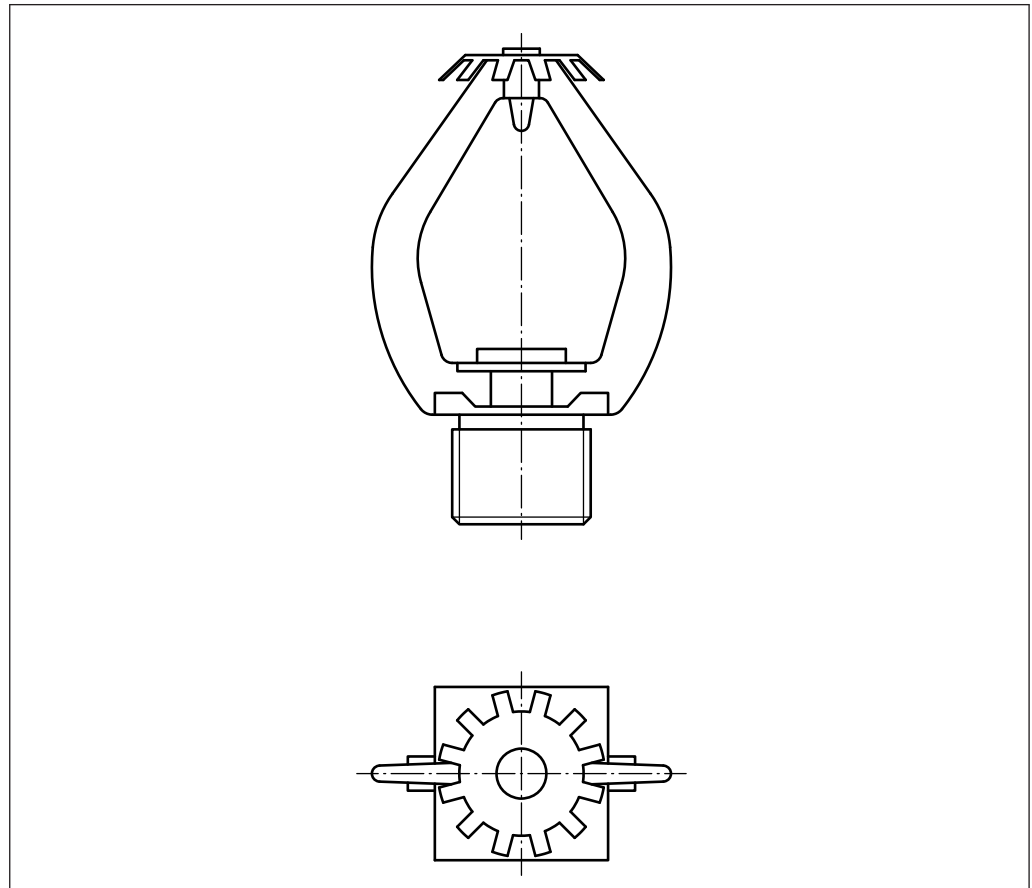

7.2 Cable sample

The sample to be tested shall be a piece of the completed cable at least 1 500 mm long, with approximately 100 mm of the sheath and outer covering removed from each end. At the ends of the cable the conductors shall be prepared for electrical connections in accordance with the manufacturer's recommendations.

7.3 Procedure

Connect the transformer or transformers to the conductors at one end of the cable, excluding any conductor that is specifically identified as intended for use as a neutral or protective conductor, as shown in the circuit diagram in Figure 2. For single, twin or three conductor cables, connect each conductor to be connected to a separate phase of the transformer output with a 2 A fuse or equivalent circuit breaker (7.1.4) in each phase. For cables with more than three conductors to be connected divide the conductors into three groups, ensuring that adjacent conductors are in different groups, as far as possible. Connect the conductors in each group in parallel and connect each group to a separate phase of the transformer output, with a 2 A fuse or equivalent circuit breaker in each phase.

At the transformer end of the sample, earth the neutral conductor, the protective conductor and any drain wire and metallic layer. At the other end of the cable connect one terminal of a lamp as described in 7.1.3 to each phase conductor and the other terminal to earth.

Attach the cable sample to the steel support as described in 7.1.2 and place the assembly in position on the test frame (see Figure 4).

Light the burner using the gas and air settings obtained in 7.1.5, switch on the electricity supply and adjust the voltage between phases to the rated voltage U (or in the case of a single-core cable to the rated voltage to earth U_0).

After the flame has been applied for 15 min, turn on the water supply to the sprinkler head at the supply conditions determined in 7.1.6 to give a spray of water over the burned area of the cable sample.

Continue the water spray for a further 15 min and also continue the flame at the same time unless the application of the water extinguishes the flame. In this case, for safety reasons, turn the gas supply off. This does not invalidate the test.

7.4 Assessment of test specimen performance

If, when the cable sample is tested, none of the fuses ruptures and none of the lamps is extinguished during the period of the test the cable shall be deemed to have passed the test.

If the sample fails to meet these criteria, two further samples shall be prepared and tested. If both these samples meet the criteria, the cable shall be deemed to have passed the test. If one or both samples fail to meet the criteria, the cable shall be deemed to have failed.

8 Protocol Z for resistance to fire with mechanical shock

8.1 Apparatus

8.1.1 Test rig, comprising a vertical board on to which the cable is mounted (8.1.2), a circuit continuity checking and voltage withstand arrangement and fuses (8.1.3 and 8.1.4), a shock producing device (8.1.5) and a source of heat (8.1.6).

NOTE A general arrangement of the test rig is shown in Figure 8. A slotted angle framework is a suitable means of supporting the components in their relative positions.

Figure 8 Rig for test for resistance to fire with mechanical shock

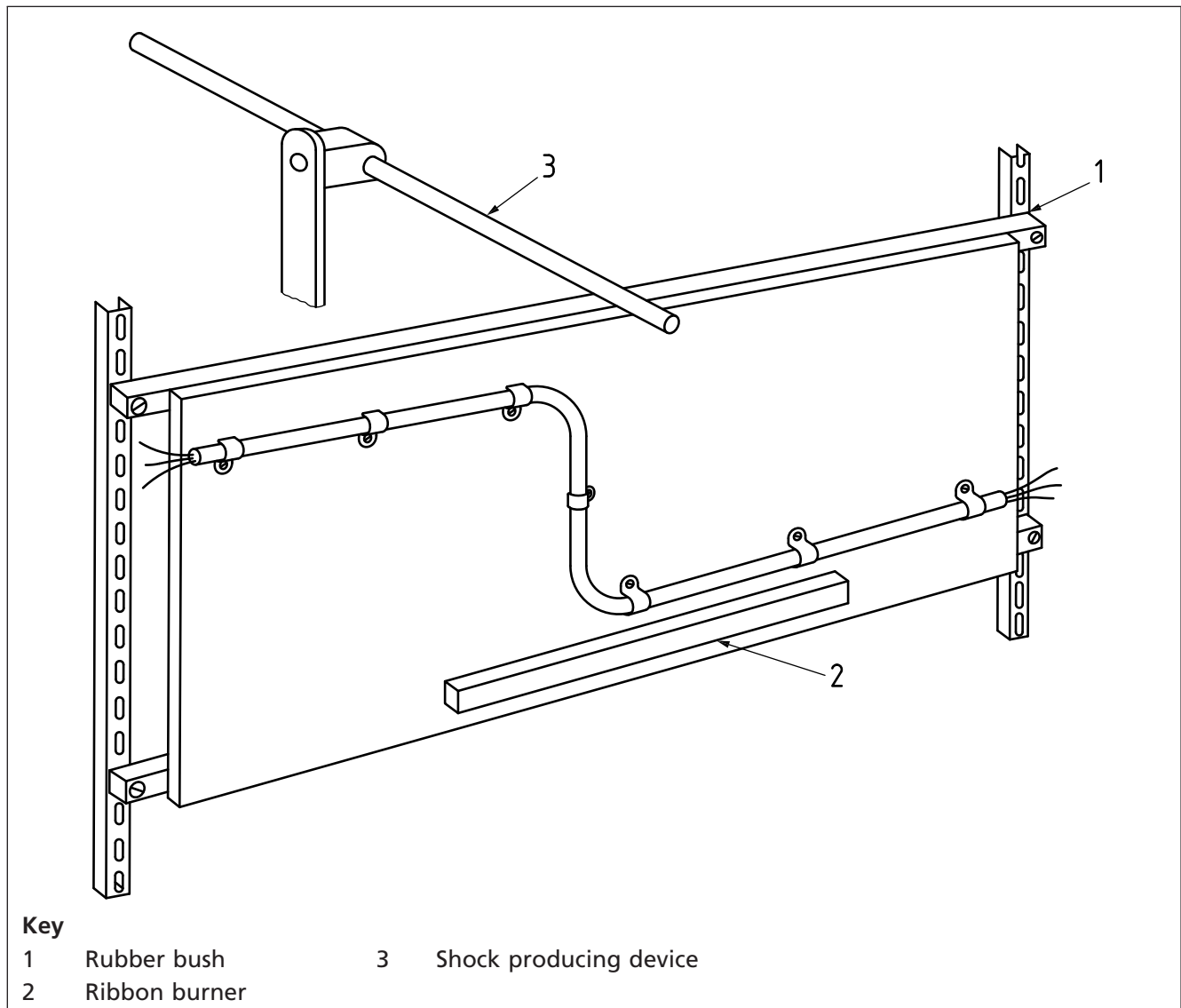

8.1.2 Vertical board and its mounting, comprising a board of heat-resisting non-combustible material fastened rigidly to two horizontal steel runners, one at the top of the board and the other at the bottom. Vertical supports may also be used. The board is of 900 mm \pm 10 mm width, 300 mm \pm 5 mm length and 9 mm \pm 0.5 mm depth and the total mass of the wall (i.e. board plus supporting frame) is 10 kg \pm 0.5 kg. Each runner is made from 25 mm \pm 1 mm square steel tube of 1 000 mm \pm 1 mm length. If required, ballast is placed inside the steel runners. The top runner is fastened to the board so that its upper face is flush with the upper edge of the board. Each runner has a horizontal hole drilled into it at each end outside the board, the exact position of each hole and its diameter being determined for the particular supporting bush used and the requirements of the supporting framework. The board is fastened to the framework by four bonded rubber bushes as shown in Figure 9.

NOTE 1 Additional guidance on suitable test equipment can be found in BS EN 50200:2006, Annex A.

NOTE 2 A small part of the board may be removed at its upper top centre to ensure that the bar does not impact the board.

A 1.5 mm Type K thermocouple conforming to BS EN 60584-1 is mounted on the board in the position shown in Figure 10 to measure the flame temperature. The thermocouple protrudes through the board so that the tip of the thermocouple is between 8 mm and 10 mm from the board.

NOTE 3 If a board shows significant signs of damage it should not be used. In the case of a dispute, a new board should be used.

Figure 9 Typical rubber bush for fastening board for test for resistance to fire with mechanical shock

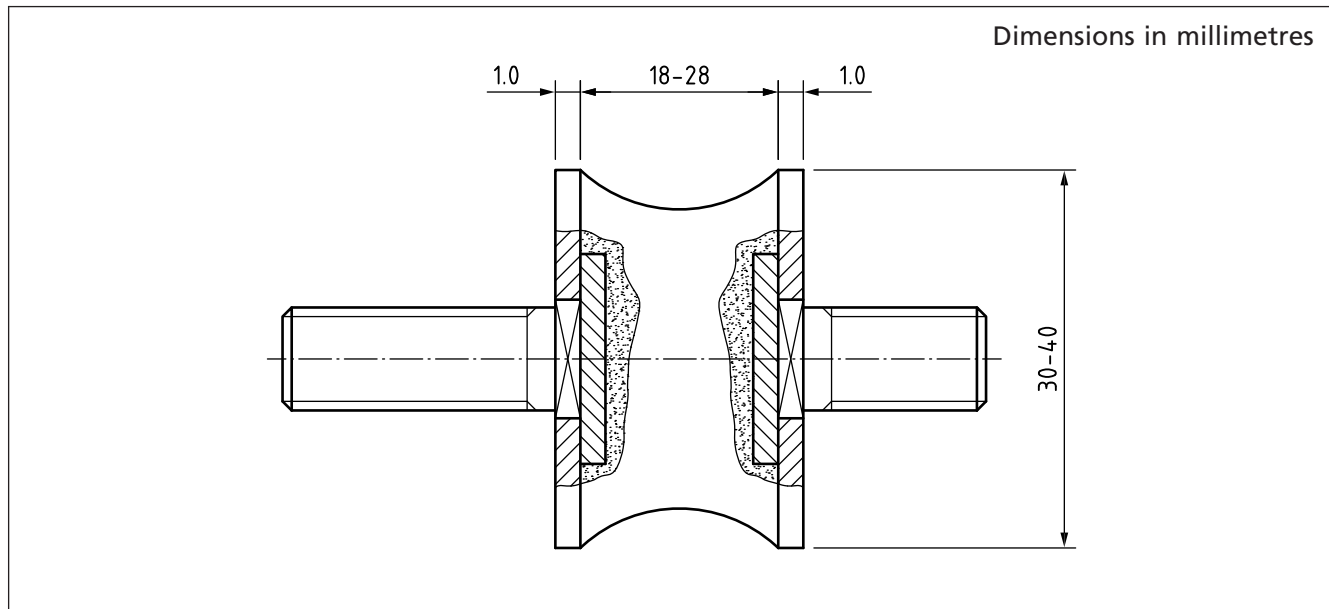

8.1.3 Circuit continuity checking and voltage withstand arrangement, comprising a three-phase star-connected transformer or three single-phase transformers (or one single-phase transformer if testing a single-core cable) of sufficient capacity to maintain the test voltage up to the maximum leakage current allowable, i.e. up to 2 A, and at the opposite end of the cable one or more lamps (with ballast resistor if necessary) connected to each core with a power rating such that each core carries a current of approximately 0.25 A at the rated voltage of the cable.

8.1.4 Fuses, IEC 60269-3:2010 Fuse system A–D, Type DII, 2A (Pink) or circuit breakers with equivalent characteristics. In case of dispute the use of fuses shall be the reference method.

8.1.5 Shock producing device, comprising a mild steel round bar 25 mm \pm 0.1 mm in diameter and 600 mm \pm 5 mm long, freely pivoted about an axis parallel to the board, which is in the same horizontal plane as, and 200 mm \pm 5 mm away from, the upper edge of the board. The axis divides the bar into two unequal sections of length 400 mm \pm 5 mm and approximately 200 mm respectively, the longer section impacting the top steel runner. Once every 30 s \pm 2 s the bar drops under its own weight from an angle of 60° to the horizontal to strike the top of the wall at its midpoint (see Figure 8).

8.1.6 Source of heat, comprising a ribbon-type propane gas burner with a nominal burner face length of 500 mm with a Venturi mixer (a centre-feed burner is recommended) and a nominal burner face width of 10 mm with three staggered rows of drilled holes, nominally 1.32 mm in diameter and drilled at 3.2 mm centres, as shown in Figure 6. Additionally a row of small holes milled on each side of the burner plate may be used, to serve as pilot holes for keeping the flame burning.

NOTE Additional guidance on suitable test equipment can be found in BS EN 50200:2006, Annex A.

The burner assembly shall be positioned so that its centre is in line with the vertical section of the cable sample. The burner assembly shall be adjusted so that a flame temperature of $950\text{ °C} \pm 40\text{ °C}$ is steadily registered for at least 5 min at the specified thermocouple position, as shown in Figure 10. Record the position of the burner assembly and the gas and air flow rates and remove the thermocouple.

Figure 10 Cable mounting for test for resistance to fire with mechanical shock

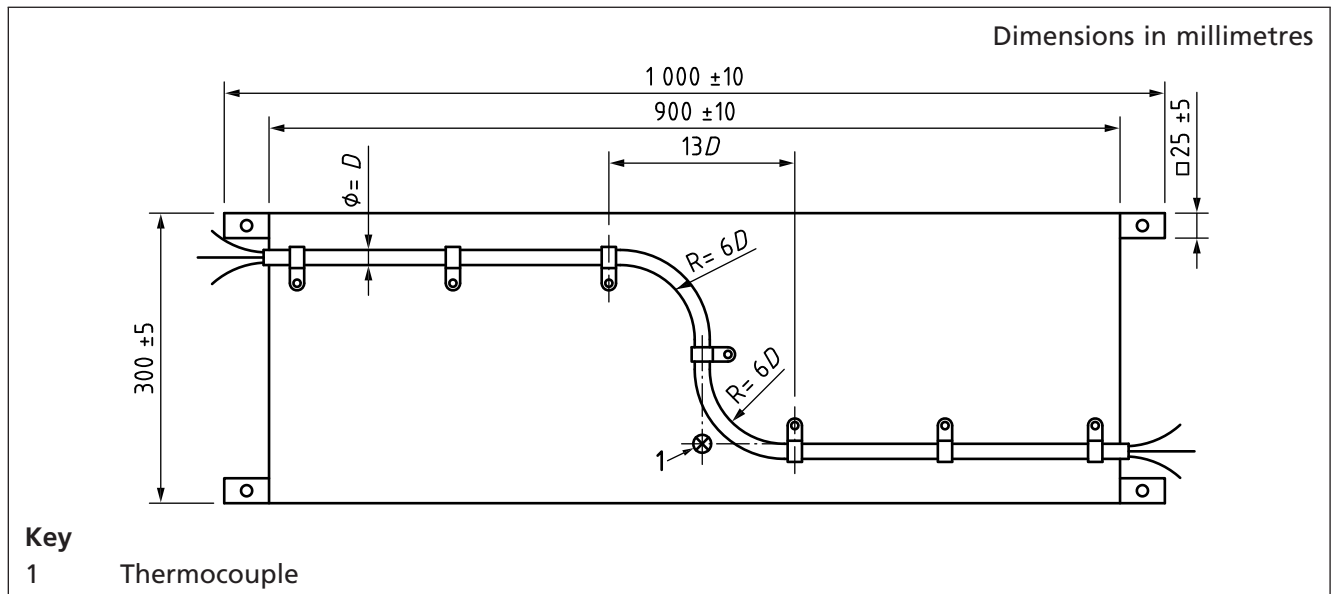

8.2 Cable sample

The sample to be tested shall be a piece of the completed cable not less than 1 200 mm long, with approximately 100 mm of the sheath and outer coverings removed from each end. At the ends of the cable the conductors shall be prepared for electrical connections in accordance with the manufacturer's recommendations.

The cable shall be bent to form two approximately equal horizontal lengths with a double bend in the middle. The internal radius of each bend shall be approximately $6D$ where D is the overall diameter of the cable. Each bend shall turn the cable through 90° so that the cable describes a Z shape, the centre of each bend being in the same horizontal plane, separated by $13D$ as shown in Figure 10.

The cable shall be mounted on the board using copper P clips, as recommended by the manufacturer for mounting the particular cable under test. The clips shall support the cable between the two bends where the cable is vertical, at the points where the cable becomes horizontal adjacent to each bend and at equal distances along the horizontal sections, the space between adjacent clips being between 150 mm and 200 mm.

8.3 Procedure

Check that the board and shock producing device are mounted as described in 8.1.2 and 8.1.5, and that the cable sample is mounted on to the board in accordance with Figure 8 and Figure 10 and that the burner is mounted at the position specified in 8.1.6. Remove the thermocouple.

Connect the transformer or transformers to the conductors at one end of the cable, excluding any conductor that is specifically identified as intended for use as a neutral or protective conductor, as shown in the circuit diagram in Figure 2. For single, twin or three conductor cables, connect each conductor to be connected to a separate phase of the transformer output with a 2 A fuse or equivalent circuit breaker (8.1.4) in each phase. For cables with more than three conductors to be connected divide the conductors into three groups, ensuring that adjacent conductors are in different groups, as far as possible. Connect the conductors in each group in parallel and connect each group to a separate phase of the transformer output, with a 2 A fuse or equivalent circuit breaker in each phase.

At the transformer end of the sample, earth the neutral conductor, the protective conductor, and any drain wire and metallic layer. At the other end of the cable connect one terminal of a lamp as described in 8.1.3 to each phase conductor and the other terminal to earth.

Light the burner using the gas and air settings obtained in 8.1.6, start the shock producing device and switch on the electricity supply and adjust the voltage between phases to the rated voltage U (or in the case of a single-core cable to the rated voltage to earth U_0).

Continue the test for 15 min.

8.4 Assessment of test specimen performance

If, when the cable sample is tested, none of the fuses ruptures and none of the lamps is extinguished during the period of the test the cable shall be deemed to have passed the test.

If the sample fails to meet these criteria, two further samples shall be prepared and tested. If both these samples meet the criteria, the cable shall be deemed to have passed the test. If one or both samples fail to meet the criteria, the cable shall be deemed to have failed.

Bibliography

Standards publications

For dated references, only the edition cited applies. For undated references, the latest edition of the referenced document (including any amendments) applies.

BS 8434 (all parts), *Methods of test for assessment of the fire integrity of electric cables*

BS 8491, *Method for assessment of fire integrity of large diameter power cables for use as components for smoke and heat control systems and certain other active fire safety systems*

BS EN 12259-1:1999, *Fixed firefighting systems – Components for sprinkler and water spray systems – Part 1: Sprinklers*

BS EN 50200:2006, *Method of test for resistance to fire of unprotected small cables for use in emergency circuits*

British Standards Institution (BSI)

BSI is the national body responsible for preparing British Standards and other standards-related publications, information and services.

BSI is incorporated by Royal Charter. British Standards and other standardization products are published by BSI Standards Limited.

About us

We bring together business, industry, government, consumers, innovators and others to shape their combined experience and expertise into standards-based solutions.

The knowledge embodied in our standards has been carefully assembled in a dependable format and refined through our open consultation process. Organizations of all sizes and across all sectors choose standards to help them achieve their goals.

Information on standards

We can provide you with the knowledge that your organization needs to succeed. Find out more about British Standards by visiting our website at bsigroup.com/standards or contacting our Customer Services team or Knowledge Centre.

Buying standards

You can buy and download PDF versions of BSI publications, including British and adopted European and international standards, through our website at bsigroup.com/shop, where hard copies can also be purchased.

If you need international and foreign standards from other Standards Development Organizations, hard copies can be ordered from our Customer Services team.

Subscriptions

Our range of subscription services are designed to make using standards easier for you. For further information on our subscription products go to bsigroup.com/subscriptions.

With **British Standards Online (BSOL)** you'll have instant access to over 55,000 British and adopted European and international standards from your desktop. It's available 24/7 and is refreshed daily so you'll always be up to date.

You can keep in touch with standards developments and receive substantial discounts on the purchase price of standards, both in single copy and subscription format, by becoming a **BSI Subscribing Member**.

PLUS is an updating service exclusive to BSI Subscribing Members. You will automatically receive the latest hard copy of your standards when they're revised or replaced.

To find out more about becoming a BSI Subscribing Member and the benefits of membership, please visit bsigroup.com/shop.

With a **Multi-User Network Licence (MUNL)** you are able to host standards publications on your intranet. Licences can cover as few or as many users as you wish. With updates supplied as soon as they're available, you can be sure your documentation is current. For further information, email bsmusales@bsigroup.com.

BSI Group Headquarters

389 Chiswick High Road London W4 4AL UK

Revisions

Our British Standards and other publications are updated by amendment or revision.

We continually improve the quality of our products and services to benefit your business. If you find an inaccuracy or ambiguity within a British Standard or other BSI publication please inform the Knowledge Centre.

Copyright

All the data, software and documentation set out in all British Standards and other BSI publications are the property of and copyrighted by BSI, or some person or entity that owns copyright in the information used (such as the international standardization bodies) and has formally licensed such information to BSI for commercial publication and use. Except as permitted under the Copyright, Designs and Patents Act 1988 no extract may be reproduced, stored in a retrieval system or transmitted in any form or by any means – electronic, photocopying, recording or otherwise – without prior written permission from BSI. Details and advice can be obtained from the Copyright & Licensing Department.

Useful Contacts:

Customer Services

Tel: +44 845 086 9001

Email (orders): orders@bsigroup.com

Email (enquiries): cservices@bsigroup.com

Subscriptions

Tel: +44 845 086 9001

Email: subscriptions@bsigroup.com

Knowledge Centre

Tel: +44 20 8996 7004

Email: knowledgecentre@bsigroup.com

Copyright & Licensing

Tel: +44 20 8996 7070

Email: copyright@bsigroup.com



...making excellence a habit.™