

Lining of equipment with polymeric materials for the process industries —

Part 5: Specification for lining with rubbers

UDC 621.772.4:66.023.3:678.074

Committees responsible for this British Standard

The preparation of this British Standard was entrusted by the Pressure Vessels Standards Committee (PVE/-) to Technical Committee PVE/1 upon which the following bodies were represented:

Amalgamated Society of Boilermakers, Shipwrights, Blacksmiths and Structural Workers
 Associated Offices Technical Committee
 Association of Consulting Engineers
 British Chemical Engineering Contractors' Association
 British Compressed Gases Association
 British Gas Corporation
 British Steel Industry
 Electricity Supply Industry in England and Wales
 Energy Industries Council
 Engineering Equipment and Materials Users' Association
 Health and Safety Executive
 Institution of Chemical Engineers
 Institution of Gas Engineers
 Institution of Mechanical Engineers
 Liquefied Petroleum Gas Industry Technical Association (UK)
 Process Plant Association
 Water-tube Boilermakers' Association
 Welding Institute
 Coopted member

The following bodies were also represented in the drafting of the standard, through subcommittees and panels:

British Rubber Manufacturers Association
 Institution of Corrosion Science and Technology
 Plastics and Rubber Institute
 Rubber and Plastics Research Association of Great Britain

This British Standard, having been prepared under the direction of the Pressure Vessels Standards Committee, was published under the authority of the Board of BSI and comes into effect on 31 July 1985

© BSI 02-1999

The following BSI references relate to the work on this standard:
 Committee reference PVE/1
 Draft for comment 82/79981 DC

Amendments issued since publication

Amd. No.	Date of issue	Comments

ISBN 0 580 14513 1

Contents

	Page
Committees responsible	Inside front cover
Foreword	ii
<hr/>	
Section 1. General	
1.1 Scope	1
1.2 Definitions	1
1.3 Exchange of information	1
1.4 Compliance	2
<hr/>	
Section 2. Design, fabrication and surface finish of equipment to be lined	
2.1 General	3
2.2 Design of metal equipment to be lined	3
2.3 Fabrication of metal equipment to be lined	4
2.4 Design of concrete equipment to be lined	4
2.5 Construction of concrete equipment to be lined	5
<hr/>	
Section 3. Selection and quality of linings	
3.1 Selection of lining	9
3.2 Quality of lining	9
<hr/>	
Section 4. Method of lining	
4.1 Surface preparation	11
4.2 Adhesion system and application	11
4.3 Production of lining material	11
4.4 Application of the sheet to the substrate	12
4.5 Vulcanization	13
<hr/>	
Section 5. Inspection and testing	
5.1 Responsibility for inspection and testing	15
5.2 Inspection	15
<hr/>	
Section 6. Methods of test	
6.1 Continuity testing	18
<hr/>	
Section 7. Rectification of faults in fully cured linings	
7.1 General	19
<hr/>	
Section 8. Storage, handling, transportation and installation	
8.1 General	20
<hr/>	
Appendix A Characteristics of lining materials specified in 3.1	21
Appendix B Continuity testing	22
Appendix C Vulcanization	24
Appendix D Lining of used equipment	25
Appendix E Maintenance of rubber lined equipment	25
Appendix F Effect of materials on water quality	26
<hr/>	
Figure 1 — Weld profile details: flanges	5
Figure 2 — Pipework details	6
Figure 3 — Weld profile details: butt welds	7
Figure 4 — Weld profile details: external corners and edges	7
Figure 5 — Weld profile details: internal corners and edges	8
Figure 6 — Weld profile details: concave heads	8
Figure 7 — Typical joints in rubber linings	13
Figure 8 — Unacceptable faults in joints in rubber linings	16
<hr/>	
Table 1 — Maximum length between flanges	3
Table 2 — Test loads for adhesion of vulcanized soft rubber to carbon steel and concrete substrates	17
Publications referred to	Inside back cover

Foreword

This Part of BS 6374 has been prepared under the direction of the Pressure Vessels Standards Committee. It is the last of five Parts of a new standard that supersedes Parts 1, 4, 5 and 6 of CP 3003 which are withdrawn. The change in format arises from the fresh approach adopted to conform with developments in the associated lining technology.

The Technical Committee would like to acknowledge the contributions made by the British Rubber Manufacturers' Association and the Rubber and Plastics Research Association of Great Britain both of which contributed to the preparation of the initial draft document.

The linings referred to in this standard which are based on natural and synthetic rubbers are used for a number of different duties, including protection against corrosive environments and prevention of contamination of products. Specific linings are used for protection against abrasion or erosion.

It has been assumed in the drafting of this British Standard that the execution of its provisions is entrusted to appropriately qualified and experienced people.

A British Standard does not purport to include all the necessary provisions of a contract. Users of British Standards are responsible for their correct application.

Compliance with a British Standard does not of itself confer immunity from legal obligations.

Summary of pages

This document comprises a front cover, an inside front cover, pages i and ii, pages 1 to 26, an inside back cover and a back cover.

This standard has been updated (see copyright date) and may have had amendments incorporated. This will be indicated in the amendment table on the inside front cover.

Section 1. General

1.1 Scope

This Part of BS 6374 specifies requirements for the lining of equipment for the process industries using cold rubber.

It includes requirements for the choice of lining and its application and also requirements for inspection of the lining and the rectification of faults. It applies to equipment fabricated in metal or concrete.

The materials considered include natural and synthetic rubbers applied as unvulcanized or pre-vulcanized sheet.

Brushed or sprayed rubber linings are not included.

NOTE 1 The linings may be applied at the applicator's works or on site.

Requirements for design and fabrication of the equipment and the state of preparation necessary for the surfaces to be lined are specified in section 2.

Requirements for storage, handling, transportation and installation of the lined equipment are specified in section 8.

NOTE 2 The titles of the publications referred to in this standard are listed on the inside back cover.

1.2 Definitions

For the purposes of this Part of BS 6374 the definitions given in BS 3558 apply, together with the following:

1.2.1 purchaser¹⁾

the organization or individual who buys the lined equipment for its own use or as an agent for the owner

1.2.2 fabricator¹⁾

the organization or individual responsible for the fabrication of the equipment to be lined

1.2.3 applicator¹⁾

the organization or individual responsible for the application of the lining

1.2.4 inspection authority¹⁾

the body or association appointed by the purchaser (or owner) to check that the design, fabrication, and lining comply with this standard

1.2.5 vulcanization

the chemical reaction resulting in the final polymerized product

1.2.6 pinhole

a small defect in the lining that would permit corrosion of the substrate under the conditions for which the lining is designed

NOTE The word "pinhole" is synonymous with "holiday" and "pore".

1.2.7 blister

a gas or liquid filled cavity within the lining material or between the lining and substrate

1.2.8 scarf joint

a joint made between two adjacent sheets of rubber by bevelling the edges of the sheets and over-lapping one prepared edge on the other (see Figure 7)

1.3 Exchange of information

Early consultation shall be arranged between all parties concerned with the application of this standard, to establish the following information which shall be fully documented. Both the definitive requirements specified in this standard and the documented items shall be satisfied before a claim of compliance with the standard can be made and verified.

- a) Design and fabrication details of the equipment to be lined and provision of drawings (see 2.2, 2.3, 2.4 and 2.5).
- b) Details of gasket materials (see 2.2.9 and 2.2.10).
- c) Details of the contents of the vessels or equipment, including trace materials [see 3.1.1 a)].
- d) The design temperature [see 3.1.1 b)].
- e) The design pressure [see 3.1.1 c)].
- f) The details of any solids to be handled [see 3.1.1 e)].
- g) Any specific mechanical properties required of the lining including suitability for machining [see 3.1.1 g)].
- h) The methods of heating and/or cooling [see 3.1.1 b)].
- i) Cleaning methods, for example, water washing, solvent washing, boiling out or steaming [see 3.1.1 a)].
- j) Where the lining work will be done.
- k) Site conditions which may affect the work, for example, availability of services.

¹⁾ Where the words "purchaser", "fabricator", "applicator" and "inspection authority" occur in the text, they are intended also to include representatives of the purchaser, fabricator, applicator and inspection authority.

- l) Any special requirements for materials used in blast cleaning (see 4.1.1.1 and 4.1.1.2).
- m) The rubber lining to be used (see 3.1.1).
- n) The minimum thickness of the vulcanized lining and where applicable the maximum thickness (see 3.2.2).
- o) The provision of test plates [see 3.2.1 c)].
- p) When the lining is to be applied outside the applicator's works and the primers and/or adhesives as applied contain solvents, the types of solvents are to be stated, together with their flash points and threshold limit values.
- q) Specified adhesion system (see 3.1.1, 3.2.3 and 4.2).
- r) The minimum and maximum allowable temperature and allowable humidity which are required for the correct application of the lining (see 4.2 and 4.4).
- s) The minimum temperature required during the vulcanization of the lining (see 4.5).
- t) The vulcanization schedule, where applicable.
- u) Inspection techniques/procedures to be employed, acceptance levels and stages of inspection (see 5.1 and 5.2).
- v) Handling, transport, storage and installation procedure (see 3.1.1 g) and 8.1.1 to 8.1.7).

1.4 Compliance

1.4.1 Fabricator

The fabricator shall comply with the following:

- a) section 2 [see 1.3 a)];
- b) 5.1 a) and b);
- c) section 8 as agreed in 1.3 v).

1.4.2 Applicator

The applicator shall comply with the following:

- a) section 3 (but see 3.2.1);
- b) section 4;
- c) 5.1 c), d), e) and f);
- d) section 6;
- e) section 7;
- f) section 8 as agreed in 1.3 v).

Section 2. Design, fabrication and surface finish of equipment to be lined

2.1 General

The basic design, fabrication and testing for mechanical reliability of the equipment to be lined shall be carried out to the appropriate British Standards and shall comply with 2.2 and 2.3 or 2.4 and 2.5 before the lining operation commences.

NOTE Rubber lining will affect heat transfer and tolerances required for joints; both features need to be considered at the design stage of the equipment.

2.2 Design of metal equipment to be lined

2.2.1 Equipment to be lined shall be sufficiently rigid that there is no possibility of deformation which would result in damage to the lining during transportation, installation and operation. When stiffeners are required, they shall normally be applied to the unlined side of the equipment.

NOTE In the case of hard rubber and ebonite linings this requirement is of particular importance.

2.2.2 The arrangements for the lifting of equipment shall be determined at the design stage.

2.2.3 The design of all equipment shall allow for access during the preparation of the surface and application of the lining and for venting of fumes evolved during the operation.

In completely enclosed vessels there shall be at least one manhole that after lining complies with BS 470 and one additional branch of not less than 75 mm bore to permit adequate circulation of air.

NOTE It is recommended that, where practicable, the minimum diameter of a manhole should be 600 mm.

2.2.4 Riveted constructions shall not be used.

2.2.5 Bolted joints shall be permitted only if they can be dismantled for lining.

2.2.6 When calculating clearances, allowance shall be made for the thickness of the lining.

2.2.7 Surfaces to be lined shall be of a smooth contour.

2.2.8 Discontinuities, crevices and sharp projections shall be avoided.

2.2.9 Fittings which have to be installed after the completion of the lining process shall be designed to be lined or fabricated from materials that will not be affected by the process conditions.

2.2.10 Normally all connections to lined parts of equipment shall be flanged. If for any reason screwed connections are required, then these parts shall be fabricated in corrosion-resistant materials.

2.2.11 Branches and outlets, except for plain ended pipes, shall be as short as possible and flanged so that the lining may be taken over the flange face to prevent the ingress of process fluid between the lining and the substrate.

NOTE Acceptable flange systems are shown in Figure 1.

Plain-ended pipes shall be designed so that the lining may be turned over the end and the outside of the pipe.

Where pads are required they shall be designed as shown in Figure 1(d). Drilled and tapped holes in pads for studs shall not penetrate the shell of the equipment.

2.2.12 Heating coils, immersion heaters and sparger pipes shall be installed after the completion of the lining process and shall be located so that no part is closer than 100 mm from a lined surface. In the case of nozzles through which heating coils, etc. enter equipment, a smaller clearance is permitted provided that the temperature of the pipe through the nozzle does not exceed 80 °C. In no case shall this clearance be less than 25 mm. Fluids introduced through sparger pipes or dip pipes shall not impinge directly on to the lining. External heating of equipment shall not be permitted without full consultation with the applicator of the lining.

2.2.13 The design of pipework shall be such as to allow ready access to welds and bends for weld and surface preparation.

NOTE 1 Pipe systems made from straight lengths with separate "standard" (1.5D) bends and tees meet this requirement. Bends should not be greater than 90°.

Where pipe systems include "non-standard" fittings their suitability for lining shall be established [see 1.3 a)]. Suitable arrangements are illustrated in Figure 2.

The maximum dimensions of pipes and fittings which can be rubber lined shall be determined during the exchange of information [see 1.3 a)]. Typical maximum lengths of straight pipe which can be rubber lined are detailed in Table 1.

Table 1 — Maximum length between flanges

Nominal pipe size	Maximum length between flanges
mm	mm
25	2 000
32	2 500
40	3 000
50	3 500
65	4 000
80 to 600	6 000

Cast iron pipework and fittings manufactured to BS 2035 are of suitable dimensions and shall be permitted for lining.

Pipes less than 25 mm diameter shall not be rubber lined. Pipes less than 450 mm diameter shall be of seamless construction only. Screwed fittings shall not be rubber lined.

Where flat face or raised face flanges are used they shall be welded square to the pipe or fitting according to normal manufacturing tolerances.

Flanges which are attached to a pipe by fillet welding (for example slip-on flanges) shall be suitably vented to allow any air trapped between fillet welds to escape to atmosphere during lining and vulcanizing.

NOTE 2 This may be accomplished by using a vent hole in the flange, providing this meets piping design standard requirements.

2.3 Fabrication of metal equipment to be lined

2.3.1 All welds shall be continuous on surfaces to be lined.

NOTE Butt welds are preferred to fillet welds.

Stitch welding, spot welding and other non-continuous welding processes shall not be used.

2.3.2 Weld surfaces shall be smooth. Some welding procedures provide surfaces of adequate smoothness but, in other cases surfaces shall be ground wholly or partly to remove weld ripples. The grinding process shall be done so that the remaining weld does not have sharp edges.

2.3.3 Welding procedures shall be chosen to avoid porosity on the side of the weld to be lined.

NOTE It is preferable that capping runs are applied to the lining side in order to minimize this effect.

All welds shall be free from the following surface defects:

- a) undercutting;
- b) cracks;
- c) porosity;
- d) any other type of surface cavity;
- e) lack of fusion.

Weld defects that are exposed either on initial inspection or after blast cleaning shall be repaired. Repairs shall be by grinding or by welding (with or without subsequent grinding) provided that the requirements for equipment design and fabrication are met.

2.3.4 Weld profile details shall be generally in accordance with Figure 1 and Figure 3 to Figure 6.

NOTE Incorrect details are also illustrated.

2.3.5 Filler materials, such as resin, putties, fillers and low melting point solders and brazes, shall not be used.

2.3.6 Before the equipment is passed for lining, all attachments to be made by welding, for example lagging cleats and lifting lugs, shall be complete.

2.3.7 All drilling shall be completed before the equipment is passed for lining. Holes to be lined shall have their edges radiused.

2.3.8 External corners and edges shall be furnished to a radius at least equal to the thickness of the rubber, internal corners and edges to a radius of at least twice the rubber thickness.

NOTE For typical edge configurations see Figure 4 and Figure 5.

2.3.9 Castings including cast iron shall be produced by foundry techniques which give dense smooth surfaces free from slag, sand and inclusions, shrinkage cavities, scabs, cracks, porosity and burrs and the entrapment of air in surface defects.

Removal of defects shall be by welding and grinding or by grinding alone. Grinding alone shall be used only for small defects such that the ground cavity blends smoothly with the casting surface and does not reduce the sound wall of the casting below the requirements of the design standard. For larger defects welding shall be used and the repair weld shall be ground flush such that it does not impair the requirements of the design standard.

2.3.10 Where there is a requirement that a rotating part shall be balanced, then this balancing shall be done both before and after lining.

2.3.11 All slag, anti-spatter compounds or similar materials shall be removed.

All weld spatter shall be removed by chipping and/or grinding.

2.3.12 Surface defects such as scores, pitting and rolling defects shall be removed by grinding, or where necessary repaired by welding provided that the requirements of design and construction are met.

2.3.13 Surfaces shall be presented to the lining applicator in a clean condition free of all contamination, for example oil, grease, temporary protective coatings, such that no pre-treatment is required other than any grit blasting which is to be part of the lining process.

2.4 Design of concrete equipment to be lined

2.4.1 Whilst it is not possible to eliminate shrinkage cracks in concrete, the design shall be such that structural cracking is eliminated. Particular attention shall be paid to avoiding cracking due to thermal stresses.

The ability of the lining to accommodate cracking of the concrete shall determine the selection of the rubber.

Equipment shall be designed to BS 8110 or BS 5337.

NOTE Equipment designed and constructed to class A of BS 5337 is liable to develop cracks up to 0.1 mm wide. Equipment designed and constructed to class B of BS 5337 is liable to develop cracks up to 0.2 mm wide.

The concrete in the case of class A of BS 5337 shall have a minimum compressive strength of 30 N/mm² and in that of class B of BS 5337, 25 N/mm².

2.4.2 If necessary, extra reinforcements shall be used and construction joints treated so as to promote a bond between adjacent areas of concrete. Expansion joints create special problems in lining and shall not be used without consultation between the purchaser and the applicator of the lining.

2.4.3 Pipes and fittings shall be designed with puddle flanges and cast into the concrete. Where necessary such fittings shall be designed in a corrosion-resistant material. Pipes and fittings shall normally be rubber lined before being cast into the concrete.

2.4.4 The arrangements for the lifting of equipment shall be determined at the design stage.

2.4.5 The design of all equipment shall allow for access during the preparation of the surface and application of the lining, and for venting of fumes evolved during the operation.

In completely enclosed vessels there shall be at least one manhole complying, after lining, with BS 470 and one additional branch of not less than 75 mm bore to permit adequate circulation of air.

NOTE It is recommended that, where practicable, the minimum diameter of a manhole should be 600 mm.

2.4.6 All corners shall be designed to be formed with a 45° fillet with a minimum leg length of 20 mm.

2.4.7 All equipment to be placed below ground level or subject to external water pressure shall be provided with a waterproof barrier on the outside of the equipment.

2.4.8 All equipment shall be designed with a minimum of 20 mm of concrete over reinforcement.

2.5 Construction of concrete equipment to be lined

2.5.1 Concrete equipment shall be constructed in accordance with BS 5337 or BS 8110 as appropriate.

2.5.2 Proper curing of the concrete shall be ensured by the use of curing membranes. If shuttering is removed in under 7 days a curing membrane shall be applied.

Concrete equipment shall be allowed to cure for 28 days before the work of lining proceeds. Concrete hardening solutions shall not be used.

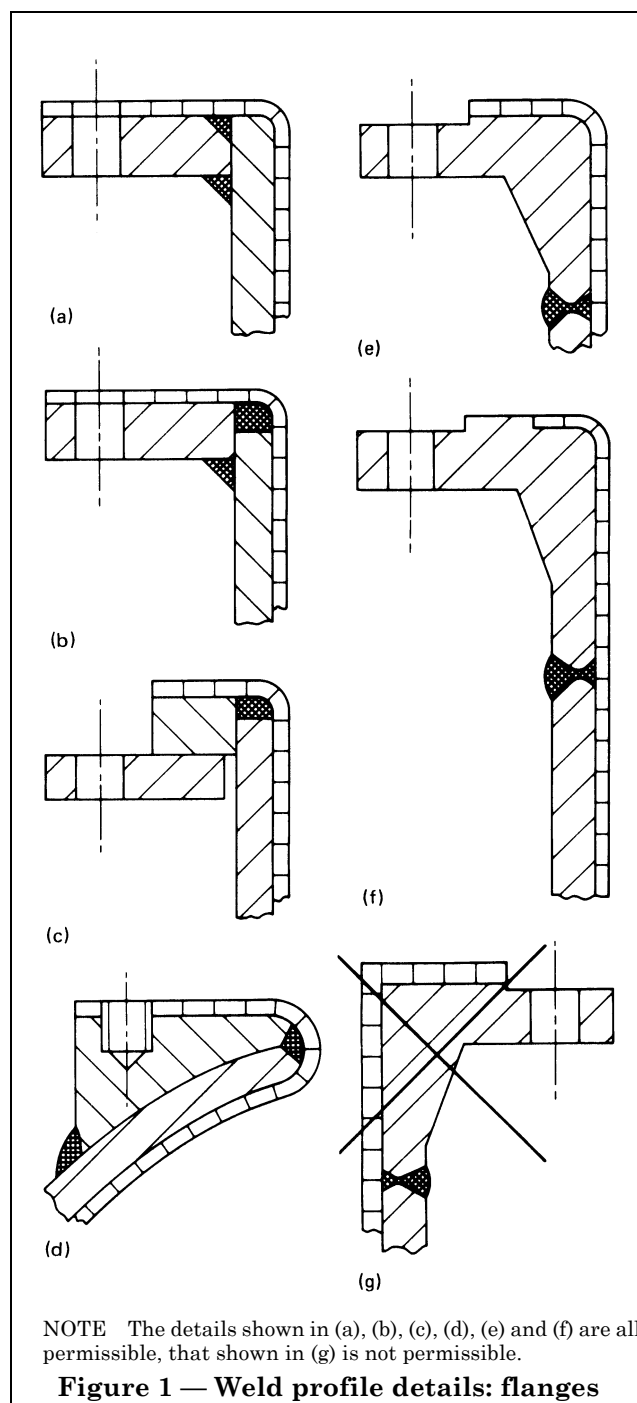

2.5.3 Equipment which is slip formed shall be bagged as the concrete leaves the formwork before the curing membrane is applied.

NOTE This process will reduce the amount of laitance.

2.5.4 All surfaces not cast against shutters shall be finished with a wooden float. Curing membranes shall be applied and not disturbed for 7 days.

2.5.5 Any steps in the concrete due to misalignment of shutters or surplus material formed because of gaps at joints in shutters shall be dressed off and ground smooth.

2.5.6 All holes left after removal of ties to secure and align formers shall be filled. Any surface defects such that the aggregate is exposed shall be filled. The material used for filling shall be a sand/cement grout with a high cement content or a sand/cement water miscible epoxy resin grout or an epoxy resin mortar.

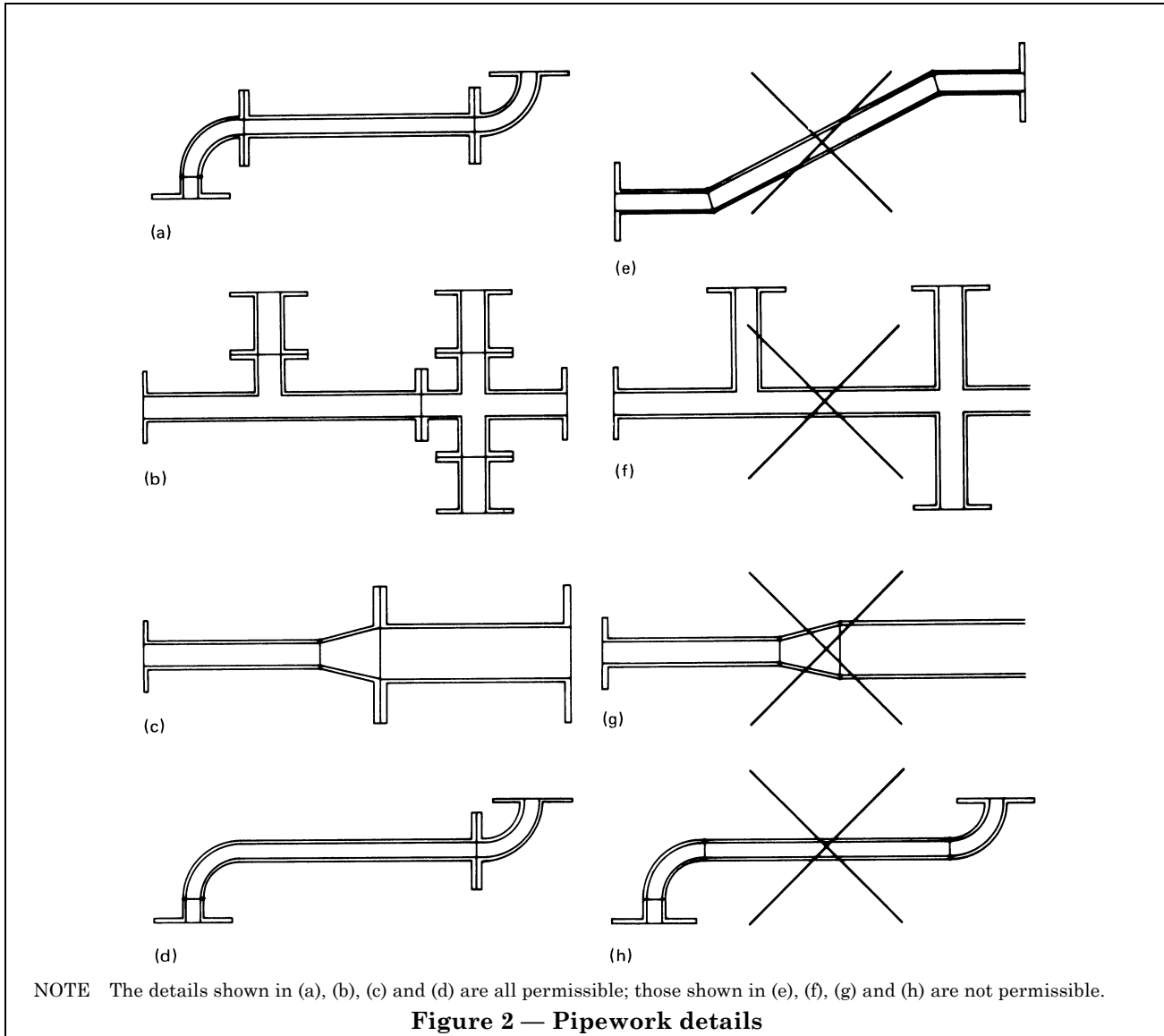

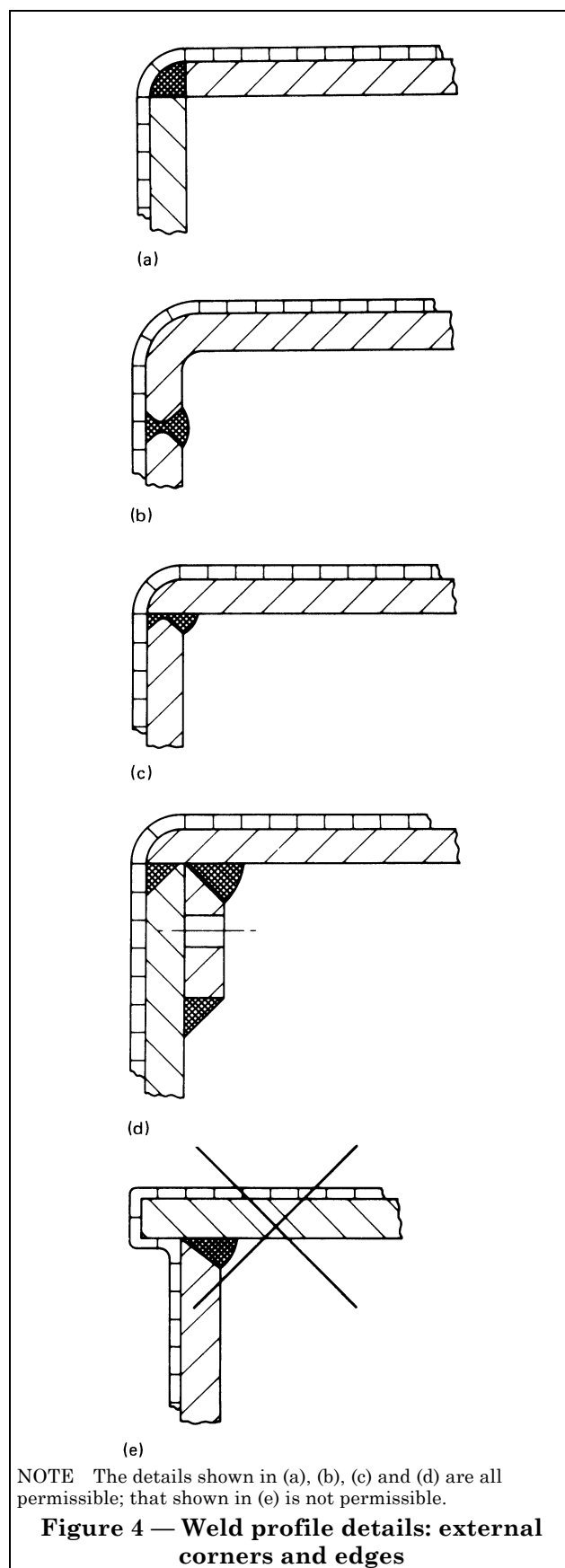
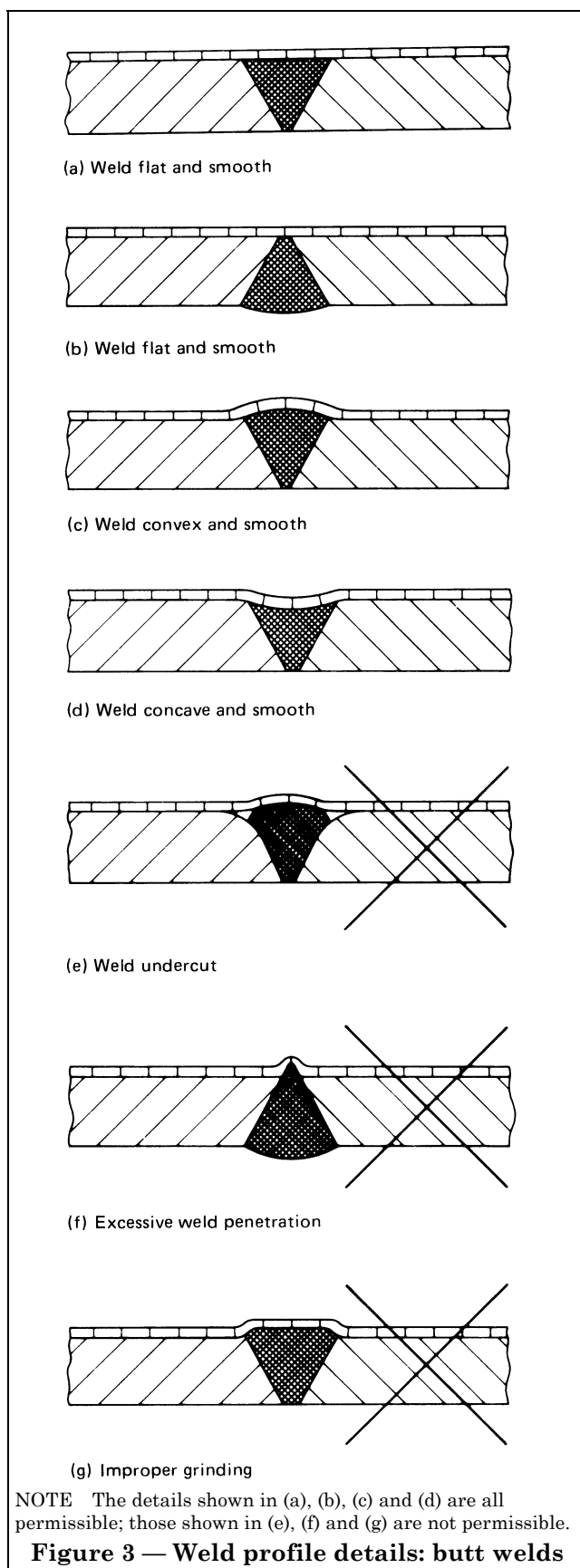

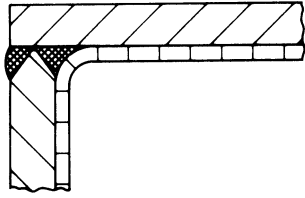

(a)

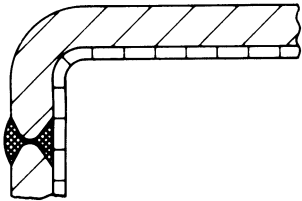

(b)

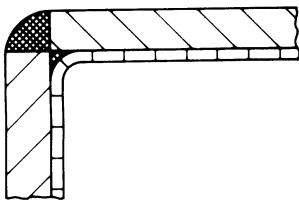

(c)

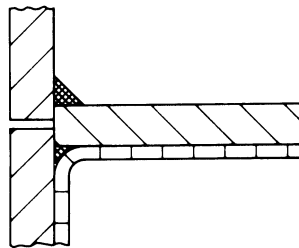

(d)

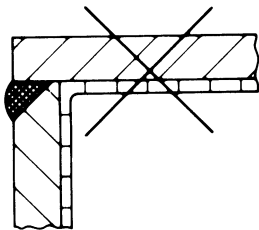

(e)

NOTE The details shown in (a), (b), (c) and (d), are all permissible; that shown in (e) is not permissible.

Figure 5 — Weld profile details: internal corners and edges

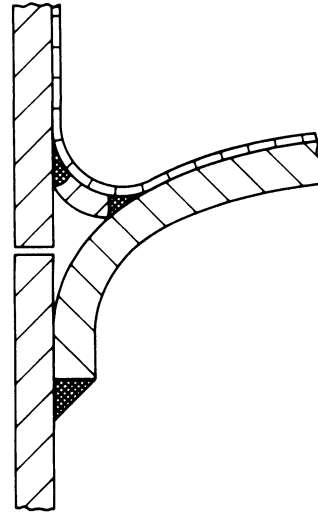

(a) Permissible

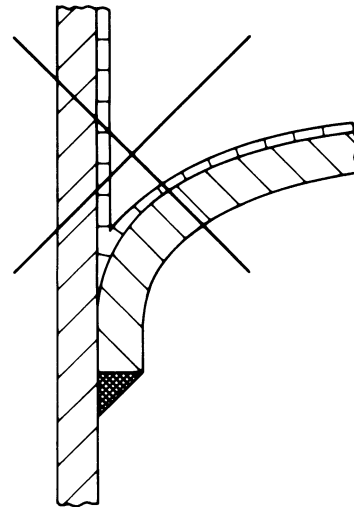

(b) Not permissible.

Figure 6 — Weld profile details: concave heads

Section 3. Selection and quality of linings

3.1 Selection of lining

3.1.1 Linings referred to in this Part of BS 6374 shall include natural and synthetic rubbers which shall be bonded to the substrate.

NOTE 1 Rubber linings are used for a number of different duties including protection against corrosive environments, protection against abrasion or erosion and prevention of contamination of products.

NOTE 2 The properties of lining materials depend not only upon the type of rubber but upon the compounding (mixing) with other ingredients, e.g. fillers, vulcanizing agents, etc. Some applicators produce their own compounds and sheet, others buy from external sources.

It shall be the responsibility of the applicator, unless otherwise agreed [see 1.3 m)], to select a compound suitable for the duty stated by the purchaser. In order to define the rubber used for a lining, a compound reference as well as the rubber type shall be stated by the applicator during the exchange of information.

The adhesive system used for bonding the rubber to the substrate shall depend upon the type of rubber and the method of vulcanization. It shall be the responsibility of the applicator to select an adhesive system which will provide an adequate bond between rubber and substrate.

NOTE 3 A description of the rubbers used for lining and a guide to their properties are given in Appendix A. Applicators will have more extensive knowledge of particular compounds and some purchasers will have particular knowledge of past performance which will help in the selection of a suitable lining material.

The selection of the rubber lining shall be based on the following information. When an applicator is to select and apply the lining full details of the duties of the equipment shall be supplied.

- a) *General*: full analysis of the contents of the equipment including constituents present in small and trace quantities, and details of cleaning operations.
- b) *Temperature of materials to be handled*:
 - 1) normal operating temperatures;
 - 2) maximum and minimum temperatures;
 - 3) cycle of temperature variation.
- c) *Degree of vacuum or pressure*:
 - 1) normal operating pressure;
 - 2) maximum and minimum pressures;
 - 3) cycle of pressure variation.
- d) *Cycle of operations*: whether batch or continuous process.
- e) *Abrasion and erosion*: details of amount, particle size and physical characteristics of the suspended matter together with rates of flow.
- f) *Mechanical damage*: any difficulties expected in the handling and final siting of the equipment or any vibration of equipment and the possibility of mechanical damage.

g) *Special requirements*: for example extremes of weather likely to be encountered during the handling, transport and storage of the equipment.

When selecting materials account shall be taken of Appendix F.

3.1.2 Unless previous experience demonstrates that a lining will be suitable for a particular duty, appropriate testing shall be carried out.

NOTE Attention is drawn to the dangers of short-term testing and the need to reproduce service conditions accurately.

Where it is not possible to place samples in process streams, service conditions shall be simulated.

Where it is known that a lining has to withstand an environment where heat transfer is made through the lining, the heat transfer condition shall be maintained during the test.

Substances including dissolved gases present in a process stream in trace quantities only shall be added to the test liquors.

3.2 Quality of lining

3.2.1 General

When the applicator is responsible for selecting the grade of lining to be applied, he shall verify that such a lining will withstand the chemical and physical conditions specified in 3.1. When the purchaser selects the grade of lining to be applied, the applicator shall be responsible only for the correct application.

The applicator shall in either case:

- a) state the reference number of the rubber to be used for the lining;
- b) state the hardness of the rubber after vulcanization;
- c) supply test pieces such as panels to which the rubber has been applied and which will serve as reference samples [see 1.3 o)].

3.2.2 Thickness of the lining

The thickness of the lining shall be selected to suit the chemical and/or mechanical duty during the exchange of information between the applicator and the purchaser. (See 1.3 n).)

NOTE 1 The minimum thickness which is acceptable is 3 mm, but thicknesses of 4 mm, 5 mm or 6 mm should be chosen as required to meet particular operating conditions.

NOTE 2 Thicknesses greater than 6 mm are normally applied in two or more layers.

Normally the thickness refers to the rubber sheet as applied to the substrate. If the purchaser requires the nominated thickness to apply to the finished lining this shall be stated during the exchange of information. (See 1.3 n).)

3.2.3 Bonding of the lining

The rubber lining shall be bonded to the substrate. The adhesive system shall be suitable for the type of rubber and for the service conditions. The applicator shall be responsible for the selection of the adhesive system and shall produce evidence that the adhesive system will produce the bond required between rubber and substrate when the rubber is applied under the conditions of vulcanization. (See 1.3 q.)

Section 4. Method of lining

4.1 Surface preparation

4.1.1 Metal

4.1.1.1 All surfaces of carbon steel and cast iron to be lined shall be blast cleaned. The standard of blasting shall be Sa 2½ as defined in Swedish Standard SIS 05 5900²⁾.

4.1.1.2 In the case of metals other than carbon steel and cast iron, methods of preparation of the substrate shall promote an acceptable bond between the substrate and the lining. The appropriate technique of substrate preparation shall be established with the lining contractors [see 1.3 l)].

4.1.1.3 All surface dust, residues and debris left on the surface after blast cleaning shall be removed.

4.1.1.4 The lining process shall start as soon as possible after blast cleaning is complete and before any visible rusting occurs. Unless maintained in a dehumidified atmosphere application of the primer shall commence within 4 h. Should signs of rusting occur then the surface shall be prepared again to the required standard (see 4.1.1.1).

4.1.1.5 All surfaces to be lined shall be maintained at a temperature of at least 3 °C above the dew point throughout the preparation and lining processes. If there is a risk that this condition will not be maintained owing to ambient conditions, dehumidifying and/or heating equipment shall be used.

4.1.2 Concrete

4.1.2.1 Any external corners not formed with a chamfer shall be rubbed down to a radius of not less than the thickness of the rubber to be used for lining.

4.1.2.2 Lining of concrete equipment shall not proceed until at least 28 days after the concrete was cast and when the free water content is down to a level specified in 1.3 a).

NOTE 1 Satisfactory adhesion of rubber lining to concrete depends upon the water content of the concrete. It is desirable that the free water content is less than 5 %. If the concrete mix used is carefully controlled it is possible that after a curing period of 28 days the water content will be down to 5 % but the required curing period may be longer.

NOTE 2 There are no reliable methods for measuring the absolute water content of concrete although moisture meters may be useful in determining problem areas. It is advisable to line a test area and measure the adhesion before proceeding with a complete lining.

4.1.2.3 Surfaces to be lined shall be treated to remove laitance and shutter release agents. Of the two possible methods for this operation the one preferred is blast cleaning. The blast cleaning process shall be controlled so that all laitance is removed and exposure of the profile of the aggregate kept to a minimum. After blast cleaning all dust and debris shall be removed.

NOTE The alternative method of removing laitance is that of acid etching. The process is more difficult to control on vertical and overhead surfaces and the presence of shutter oils will reduce its effectiveness. The thickness of the laitance of a concrete surface varies considerably and it is very important that acid is allowed to dwell on the surface a sufficient length of time to remove all laitance. When acid etching is used the next operation is water washing of the concrete, followed by a drying process.

4.1.2.4 Unless the lining material will fill or effectively bridge the large number of small holes (of varying diameter and depth) that invariably remain in the concrete surface following the removal of laitance, then these holes shall be filled before the work of lining commences.

NOTE One material recommended for this purpose is a smooth paste made from a water miscible epoxy resin and a fine filler and cement. (See 2.5.6.)

4.1.2.5 After removal of laitance all surfaces to be lined shall be maintained at a temperature at least 3 °C above the dew point throughout the preparation and lining processes. If there is a risk that this condition will not be maintained owing to ambient conditions or a change in ambient conditions, dehumidifying and/or heating equipment shall be used.

4.2 Adhesion system and application

The adhesive system shall be such that the required level of adhesion between the lining and the substrate is achieved upon completion of the lining process.

NOTE The adhesive system may consist of one or more individual layers. The primer already applied to the substrate may also be considered as part of the adhesive system.

The adhesives shall be applied to the primed substrate surface by brush, roller or spray, any solvents in the adhesive being allowed to evaporate between the application of successive coats or subsequent application of the lining.

4.3 Production of lining material

4.3.1 Thickness tolerance

The thickness tolerance on nominal dimensions of the rubber sheet shall be ± 10 %.

²⁾ Available from BSI, Linford Wood, Milton Keynes MK 14 6LE.

4.3.2 Freedom from imperfections

The sheet shall be free from blisters or other imperfections which would adversely affect the quality of the lining.

4.3.3 Unvulcanized lining materials

Lining materials shall be produced using a calender, extruder or roller die.

- a) When linings are produced by calendering, multi-ply construction shall be employed.

NOTE The minimum number of plies employed in the manufacture of a finished sheet depends upon the rubber compound. A guide to the number of plies related to a given thickness is given below:

Thickness of lining	Minimum number of plies
mm	
3 to 5	3
6	4

- b) When roller die or extrusion methods are used for the production of lining materials then single-ply or multi-ply sheets are permissible.

4.3.4 Pre-vulcanized lining materials

The unvulcanized lining sheet shall be prepared in accordance with 4.3.3 and shall then be vulcanized by heating (normally under pressure in an autoclave) or by a rotary vulcanization process.

4.4 Application of the sheet to the substrate

4.4.1 General

Detailed methods of working are not specified in this standard but the requirements specified in 4.4.2 to 4.4.5 shall be met according to whether unvulcanized sheet, prevulcanized sheet or a combination of the two is being used.

4.4.2 Preparation of lining sheet

4.4.2.1 In the case of unvulcanized sheet any preshrinking necessary shall be carried out as a first step.

4.4.2.2 Individual sheets shall be tailored to fit the surface to be lined. Edges shall be prepared according to the type of joint to be used. Types of joints are illustrated in Figure 7. The details of edge preparation shall be as follows.

- a) *Overlap scarf joint*. The edges shall be bevelled at 30° to 35°.
- b) *Simple scarf joint*. The edges shall be bevelled at 40° to 50°.
- c) *Cover straps*. The edges shall be bevelled at 30° to 35°.

4.4.3 Joints

Depending upon the type of sheet being applied and the method of lining, one of the following types of joint shall be used.

- a) *Overlap scarf joint*. This type of joint is illustrated in Figure 7(a). The total length of the contacting surface between adjacent sheets shall be a minimum of four times the sheet thickness but shall not exceed 32 mm at any point.

NOTE It is preferable that overlap scarf joints should be made so that the overlap follows the direction of flow.

Overlap scarf joints will tend to affect the flow in pipes and that effect may be significant in the case of small bore pipes, a fact which shall be considered when the equipment is designed. Overlap scarf joints on mating surfaces shall be dressed as necessary to allow efficient sealing when assembled.

- b) *Straight scarf joints* shall be made as illustrated in Figure 7(b).

c) *Strapped joints* shall be made as illustrated in Figure 7(c). The scarf joint in the parent sheet shall pass a spark test before the cover strap is fitted. The cover strap with edges bevelled shall be aligned centrally over the joint. The maximum path from an edge of the strap to the substrate shall not exceed 32 mm.

NOTE The thickness of the strap may be less than the thickness of the lining.

d) Joints in multiple layer linings shall be scarfed as illustrated in Figure 7(b). Joints within one layer shall be offset relative to joints on adjacent layers. The distance between joints on adjacent layers shall be a maximum consistent with the geometry of the equipment.

4.4.4 Pretreatment of lining sheets

The contacting face of the lining sheet shall be made tacky so as to adhere to the adhesive layer already on the substrate. Tackiness shall be produced by either wiping with a suitable solvent or the application of a coat of adhesive. In either case solvents shall be allowed to evaporate before the sheet is applied to the surface to be lined.

4.4.5 Fitting of lining sheet to the substrate

4.4.5.1 *Exclusion of air*. In the application of linings air shall be excluded between the substrate and lining and between adjacent layers in multilayer linings.

NOTE Exclusion of air is achieved by pressing the lining against the substrate with a roller or by other means in a systematic manner. Suitable tools should be used to ensure complete contact of rubber to substrate at changes of direction and rubber to rubber at joints.

4.4.5.2 Continuity of lining. When fitting of the sheet is complete all sheets and joints whether overlap, scarf, straight scarf or strapped joints shall be free from pinholes and other defects.

4.5 Vulcanization

4.5.1 General

Vulcanization of the lining shall be carried out by one of the following methods:

- autoclave vulcanization;
- using equipment as its own autoclave;
- steam or hot air vulcanization at ambient pressure;
- hot water vulcanization;
- self vulcanization at ambient temperature.

NOTE The method employed depends upon the design and size of the equipment. It may be necessary to shield the equipment to reduce heat losses which would otherwise lengthen the duration of vulcanization when using methods b), c) or d).

The duration of vulcanization will depend upon the method used and the composition of the lining material.

With the agreement of the applicator [see 1.3 t) and u)] interruption of vulcanization shall be permitted to detect and repair any faults present. The equipment shall then undergo further heat treatment to complete the vulcanization. An inspection for faults shall be carried out in accordance with section 5.

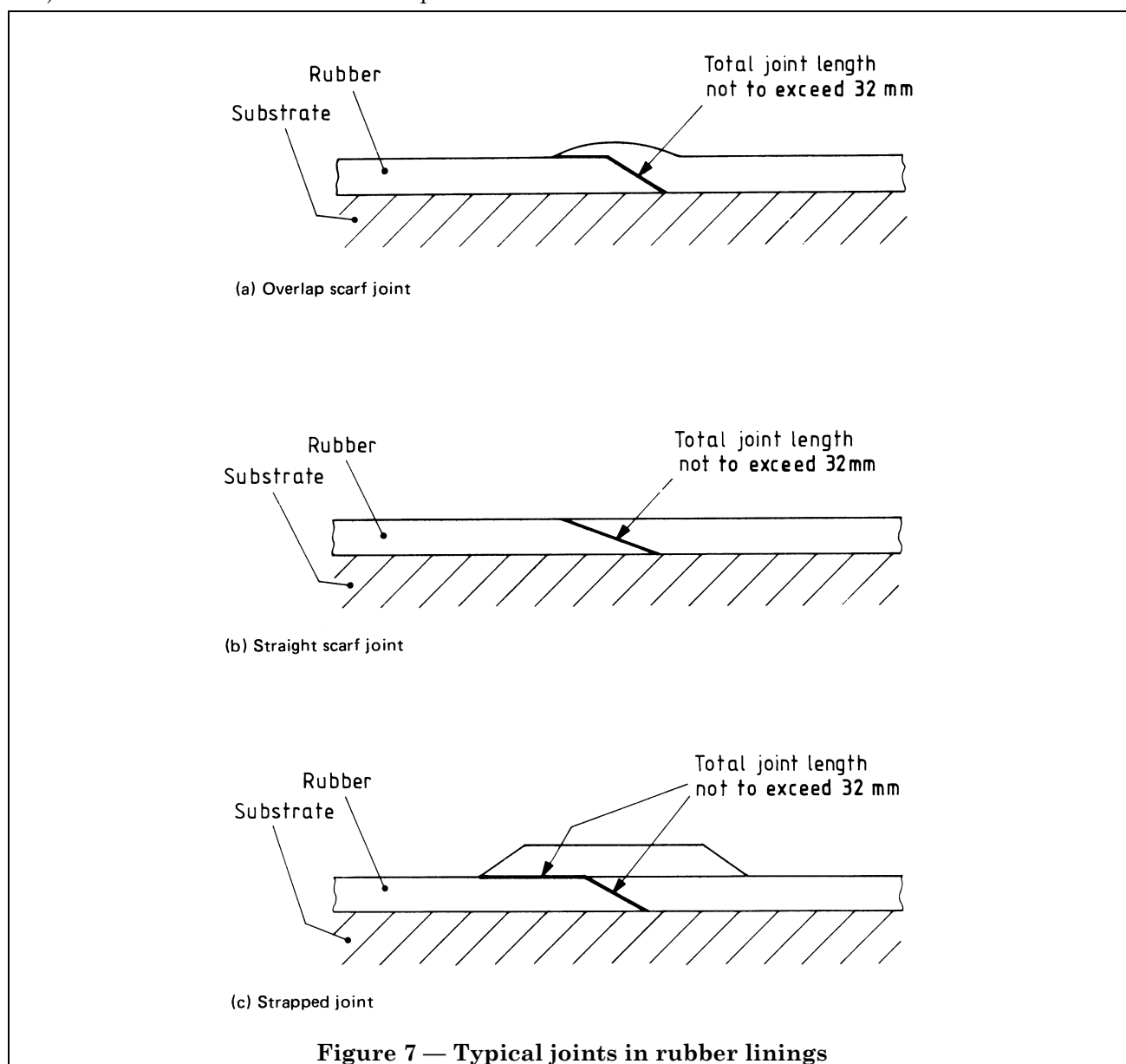

4.5.2 Methods of vulcanization

4.5.2.1 Autoclave vulcanization. The equipment shall be placed in an autoclave which is then heated to the required temperature and pressure.

4.5.2.2 Using equipment as its own autoclave. With all outlets sealed and a steam trap condensate drain attached to a convenient outlet to ensure continuous removal of condensate, saturated steam shall be injected until the equipment is pressurized to a predetermined pressure. The pressure shall be within the design pressure limits of the equipment. Precautions shall be taken against failure of the steam supply since, in such cases, condensation can cause a vacuum and collapse the vessel.

4.5.2.3 Steam or hot air vulcanization at ambient pressure. With outlets covered to reduce steam losses and provision made to drain condensate from the equipment, the steam shall be injected until the vulcanization temperature is attained. This temperature shall be maintained for the required time period. Attention is drawn to 4.5.2.2 regarding failure of steam supply.

NOTE Hot air may be used as an alternative to steam in some cases provided that the temperature and heat input can be achieved.

4.5.2.4 Hot water vulcanization. With all outlets below the top flange sealed off and the equipment partially filled with water, steam shall then be injected into the water, raising the water level and temperature. If the water reaches boiling point before the equipment is full, further water shall be added to attain the required level. The temperature shall then be maintained for the required time period while maintaining the water level.

4.5.2.5 Self vulcanization at ambient temperature. Such rubber linings shall be specially designed so that they are capable of vulcanizing under ambient conditions.

NOTE The time to vulcanize is temperature-dependent and at temperatures below 15 °C it may be necessary to use supplementary heating in order to reduce vulcanization times to an acceptable period.

Section 5. Inspection and testing

5.1 Responsibility for inspection and testing

The fabricator of the equipment and the applicator of the lining when requested shall provide a certificate of inspection and testing. The stages of inspection shall be as follows:

- a) the equipment as fabricated;
- b) the equipment after preparation of welds and edges in the case of metals; surfaces and edges in the case of concrete;
- c) the equipment after blast cleaning;
- d) the materials to be used in the lining process;
- e) after the lining has been applied and before vulcanization;
- f) when the arrangements are made to interrupt vulcanization;
- g) after vulcanization is complete;
- h) whenever remedial work is carried out.

In cases where the purchaser requires independent inspection of the work (i.e. by the inspection authority) at various stages, those stages shall be defined [see 1.3 u)].

5.2 Inspection

5.2.1 Surface cleanliness and profile of metal surfaces

Blast-cleaned surfaces shall be inspected to ensure that they comply with 4.1.1.

Reference photographs or plates shall be used to establish the level of surface cleanliness (see 4.1.1.3).

If inspection of equipment after blast cleaning reveals defects in material or welds, the applicator shall inform the fabricator and/or the purchaser and any remedial action shall be determined after consultation between the parties concerned [see 1.3 u)].

5.2.2 Concrete surfaces

Concrete surfaces shall be inspected to see that they are free from laitance and that surface defects are properly filled.

5.2.3 Quality of the lining and bonding materials

Before proceeding the applicator shall ensure that all materials to be used in the lining process are visually examined and where appropriate, physically and practically tested to confirm that they are in an acceptable condition. For the unvulcanized rubber sheeting this shall include:

- a) visual examination to ensure that it has no imperfection which could significantly affect the performance of the finished vulcanized lining;

- b) visual and physical examination to ensure that it has been prepared in accordance with section 4 and that the actual thickness is within $\pm 10\%$ of the specified thickness;

- c) a test to ensure that the sample taken from each roll achieves the correct hardness when vulcanized in accordance with the customary practice of the applicator.

5.2.4 Visual appearance of the lining

5.2.4.1 Inspection for visible defects shall be carried out over the entire surface of the lining in a good light, attention being paid to any areas of mechanical damage, cuts, blisters, lack of adhesion and poor jointing.

5.2.4.2 If the applicator finds a defect prior to vulcanization it shall be removed and the area overlaid with unvulcanized rubber of the same type as the original unvulcanized rubber on to which it is bonded. After subsequent vulcanization the area concerned shall be considered identical to a lap joint or seam and thus fully acceptable.

5.2.4.3 All scarf joints shall be closely inspected. Any separation of the joint shall be investigated (see Figure 8). If the extent of the separation is small then the rubber shall be ground back. If the separation of the rubber is extensive then the joint and rubber adjacent to the joint shall be removed and replaced.

5.2.4.4 To repair defects found after vulcanization, the surface of the lining local to the defect shall be prepared by abrading. Adhesive and a patch of unvulcanized rubber both of the same type as used for the lining shall then be applied. The size of this patch shall not be greater than 25 mm in any direction beyond the defect.

The patch shall then be vulcanized.

After rectification, the repaired area shall be tested for pinholes.

Minor wrinkles and surface markings which have no significant effect on the performance of the lining shall be acceptable.

NOTE After vulcanization defects such as blisters, blow holes, small cracks or scuffed areas in the lining may be found. When such faults are discovered after vulcanization the defect may be patched.

5.2.5 Hardness tests

5.2.5.1 *General procedure.* The extent of vulcanization shall be checked by a hardness test. If actual hardness levels measured indicate that further vulcanization is required the lining shall be retested after such vulcanization.

5.2.5.2 *Test surfaces.* Hardness testing shall be carried out on a flat, smooth surface and not on a curved surface.

In vessels where readings cannot be taken on a surface of the lining, buttons shall be provided in suitable positions [see 1.3 u)]. If the surface is too rough a light local scraping or buffing to facilitate testing is permissible.

5.2.5.3 Hardness testing. The hardness of soft rubbers shall be measured with a portable hardness meter calibrated in degrees on the IRH scale in accordance with BS 2719. The hardness of hard rubbers and ebonites shall be measured with a portable hardness meter calibrated in degrees on the Shore "D" scale.

Hardness readings shall conform to the specified hardness of the compound within $\pm 5^\circ$. Three hardness readings shall be taken for each panel of rubber. When a reading is outside the agreed range further readings shall be taken on that panel to establish the general level of hardness. Where repairs have been carried out or where water marking is visible the areas concerned shall be specifically tested.

5.2.6 Continuity of lining: high frequency spark test

Testing for pinholes and other discontinuities shall be carried out (see section 6):

- when the rubber has been applied and before vulcanization;
- after interrupted vulcanization;
- after complete vulcanization;
- after any remedial work.

5.2.7 Bond strength tests

NOTE Because there is no quantitative non-destructive test for assessing the bond strength between a rubber lining and the substrate no routine bond strength tests are specified for the actual lining as part of the inspection procedure. The bond strength for a particular combination of substrate, rubber and adhesive system may be established by laboratory testing.

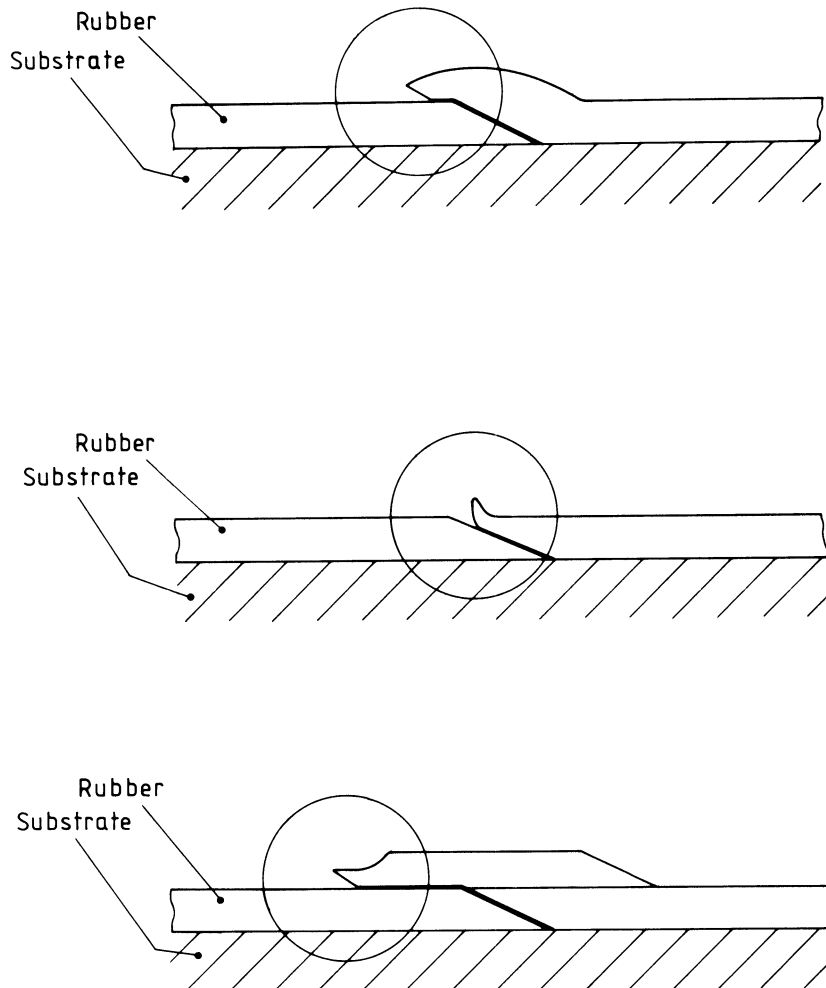

Figure 8 — Unacceptable faults in joints in rubber linings

5.2.7.1 All open edges, for example flanges, shall be examined by hand for evidence of poor bond strength. If further evidence is required to show that the bond between the substrate and the rubber is satisfactory the provision of test samples shall be specified during the relevant discussions at an early stage [see 1.3 q)].

Test samples shall consist of pieces of substrate, similar to that used in the manufacture of the equipment, to which has been applied rubber of the same mix and thickness used for the main lining. The adhesive system shall be the same as that used for lining. The conditions of application shall be the same. Vulcanization shall be carried out at the same time as the lining, in the same autoclave or inside the equipment when vulcanization takes place outside of an autoclave.

5.2.7.2 The bond strength between rubber and a substrate shall be measured by method B described in BS 903-A21.

NOTE There is no quantitative test for measuring the bond strength of hard rubber or ebonite to substrates. A qualitative assessment of the bond can be made by chipping the lining on a test plate with a chisel 25 mm wide when it should be possible to loosen only small pieces of hard rubber or ebonite at each blow.

5.2.7.3 Minimum load figures for bond strengths obtainable with various types of rubbers, vulcanized by different methods, shall be as given in Table 2.

NOTE The manner of stripping is of great significance. If the metal is clean or if failure has occurred at the rubber/adhesive interface this should be taken as an indication of an unsatisfactory bond. A properly bonded sample should leave traces of rubber sheet adhering to metal indicating failure within the rubber.

5.2.8 Lining thickness check

The thickness of the lining shall be checked. Where direct measurement is not possible a suitable thickness meter shall be used.

5.2.9 Hydraulic testing of lined equipment

Normally pressure testing of equipment is completed before the commencement of the lining operation. When specified, pressure tests shall be carried out [see 1.3 u)]. The joint rings used for this test shall be of the same material and the same dimensions as those specified for the final service conditions. During a pressure test no leakage shall occur. The lining shall be subsequently reinspected for defects.

5.2.10 Vacuum testing of lined equipment

When specified, a vacuum test within the design limits of the equipment shall be carried out by evacuating the lined equipment with the appropriate joint rings in position, to a specified vacuum [see 1.3 u)]. The vacuum shall be maintained for a specified period (normally one hour). The lining shall be subsequently reinspected for defects.

Table 2 — Test loads for adhesion of vulcanized soft rubber to carbon steel and concrete substrates

Types of rubber	Carbon steel			Concrete
	Pressure vulcanization	Vulcanization by hot water or steam at atmospheric pressure	Self-vulcanization at ambient temperature	
	kN/m	kN/m	kN/m	kN/m
Natural or synthetic polyisoprene	3.5	2.7	2.7	1.0
Styrene-butadiene	3.5	2.7	2.7	1.0
Polychloroprene	3.5	2.7	2.7	1.0
Butyl	3.5	2.7	2.7	1.0
Ethylene-propylene	3.5	2.7	—	1.0
Nitrile	3.5	2.7	2.7	1.0
Butadiene and/or blends	3.5	2.7	—	—
Chlorosulphonated polyethylene	2.7	2.7	—	1.0

Section 6. Methods of test

6.1 Continuity testing

6.1.1 General

The testing of linings shall be done in a systematic way. The surface of all but small equipment shall be divided up by chalk line or other suitable marks into smaller areas of about 1 m².

NOTE By these means it is possible to check that the whole of the lining has been examined.

The rectification of faults discovered before vulcanization shall be a normal part of the lining procedure.

6.1.2 Spark testing

The instrument used shall be an a.c. high frequency spark tester and the voltage shall be adjusted to that agreed under 1.3 u).

NOTE Normally the spark length should not be less than 32 mm when applied across the surface of the rubber. Very thin linings or linings where the rubber has a high conductivity may require the test to be modified. Further information on spark testing is given in Appendix B.

Before testing begins the surface shall be made dry and free from dirt.

The probe shall be moved continuously over the surface of the lining at a speed not exceeding 100 mm/s. Applying the spark to one spot for any appreciable length of time shall be avoided.

When a defect in the lining is discovered it shall be clearly marked.

If it is necessary to carry out any machining of hard rubber or ebonite linings, the spark test shall be applied again to the lining to ensure that it has not been damaged in any way.

Section 7. Rectification of faults in fully cured linings

7.1 General

7.1.1 When rectification of faults is to be made in linings which are fully vulcanized special attention shall be paid to the problems of achieving adhesion between the new rubber and the vulcanized lining.

7.1.2 With all linings a patch which extends 25 mm beyond the area to be repaired shall be abraded to promote adhesion.

7.1.3 When priming of the substrate is an essential part of the system the first step after preparation shall be to establish whether the primer is intact. If the primer is damaged then it shall be repaired before the rest of the work proceeds.

7.1.4 Rectification of faults using other than the original material used for the lining shall only be permitted with the written permission of the purchaser.

7.1.5 After all rectification work the lining shall be subject to inspection as appropriate and in particular to continuity testing.

Section 8. Storage, handling, transportation and installation

8.1 General

8.1.1 Lined equipment shall be stored under cover or in a protected compound. When necessary, linings shall be shielded from direct sunlight.

8.1.2 All branches, manholes and other openings shall be protected from mechanical damage by using wooden blanks or other suitable material.

8.1.3 Lifting shall be arranged so that chains and other lifting aids do not come into contact with lined surfaces.

8.1.4 High local loads on lined surfaces shall be avoided.

8.1.5 Loose fittings shall not be placed inside lined equipment whilst it is being transported.

8.1.6 Responsibility for arranging transport of lined equipment will vary and whoever is responsible (purchaser, fabricator or applicator) shall instruct the carrier about the precautions in handling [see 1.3 v)].

8.1.7 It is essential that the purchaser issues instructions to those responsible for installation on the handling procedures and special reference is made to the need to wear soft clean footwear when entering lined equipment and the need to protect lined surfaces from ladders and scaffold poles.

Appendix A Characteristics of lining materials specified in 3.1

A.1 General

A.1.1 Rubbers are elastomeric polymers consisting of long chain macromolecules which, on mixing with suitable reactants that form strong chemical bonds, change from a soft deformable substance into an elastic material.

A.1.2 The chemical resistance and physical properties may vary widely according to the type of rubber, the amount and type of fillers, processing aids, vulcanizing system and other additives used.

A.1.3 When the level of vulcanizing agents used gives a low proportion of cross links then soft rubber linings are produced. Certain of the rubbers when saturated with a suitable vulcanization agent are converted into hard rubber or ebonites which are characterized by high tensile strength, low elongation at break and generally enhanced chemical resistance when compared to soft rubbers based on the same type of rubber.

A.1.4 Rubber linings are generally designed for vulcanization at elevated temperatures but similar rubber linings containing accelerated systems capable of promoting vulcanization at ambient temperatures are also available. Certain rubber linings can be applied in the form of pre-vulcanized sheets or laminates.

A.1.5 The temperature range capability of a particular rubber or compound lining will vary depending upon the chemical environment to which it is exposed and the composition of the rubber compound.

A.1.6 Soft rubber linings intended specifically for conditions which are erosive or abrasive are obtainable.

A.2 Types of rubber and properties of linings

A.2.1 The types of linings produced from various rubbers are divided into two groups: soft and hard. Soft rubber linings normally have a hardness range of 40° to 80° IRHD, and hard rubber linings and ebonites have a hardness range of 25° to 80° on the Shore D scale.

A.2.2 Because there are so many factors which govern the detailed properties of vulcanized rubbers it is not possible when describing individual types of rubber to be precise about the chemical resistance and the temperature range over which they may be used. Therefore the information in **A.3** and **A.4** about the different rubbers is intended for guidance only and for more precise information on particular linings advice should be sought from the individual lining contractors.

A.3 Soft rubber linings

A.3.1 *Natural (NR) or synthetic polyisoprene (IR) rubber*

Lining compounds based on polyisoprene rubber are resistant to the majority of inorganic chemicals with the exception of strong oxidizing agents. Resistance to organic chemicals is limited with the rubber being unsuitable for use with hydrocarbons, halogenated hydrocarbons, mineral oils, many vegetable oils and esters. When suitably compounded polyisoprene can be used over the temperature range of – 30 °C to + 100 °C.

A.3.2 *Styrene-butadiene rubber (SBR)*

Co-polymers of styrene-butadiene have properties broadly similar to those of the polyisoprene rubbers, when compounded for the same duties.

A.3.3 *Polychloroprene rubber (CR)*

Polychloroprenes give lining compounds with greater resistance to heat, ozone, sunlight and many oils compared to polyisoprene rubbers. They should not be used with halogenated hydrocarbons or aromatic hydrocarbons.

Selected polymer grades can be used continuously within the temperature range – 20 °C to + 100 °C depending on the polymer crystallinity and compound design.

A.3.4 *Butyl rubber (IIR)*

Butyl rubbers are co-polymers of isobutylene with small proportions of isoprene. Chlorinated or brominated butyl rubbers which are generally easier to process are also available.

Lining compounds based on butyl rubbers have very good resistance to heat and chemicals including some oxidizing chemicals and have low permeability to gases. They should not be used in the presence of free halogens, petroleum oils, hydrocarbons and halogenated hydrocarbons.

When suitably compounded, linings based on butyl rubbers have a lower water absorption than most other rubbers and can be used within the temperature range – 30 °C to + 120 °C.

A.3.5 *Ethylene propylene rubbers (EPR or EPDM)*

Ethylene propylene rubbers are available as the co-polymer (EPR) or the ter-polymer (EPDM). Lining compounds based on these polymers have a very good resistance to acids, alkalis, salts, ozone and many organic chemicals but are not resistant to oils, hydrocarbons and chlorinated solvents.

The polymers may be compounded for use within the temperature range – 30 °C to + 110 °C.

A.3.6 Nitrile rubbers (NBR and XNBR)

Acrylonitrile butadiene co-polymer (nitrile rubber NBR) and its variant, carboxylated nitrile rubber (XNBR), have excellent resistance to swelling by mineral oils and fuels. Polymers of high acrylonitrile to butadiene ratios have the best resistance and also have lower gas permeability. Higher butadiene ratios have better low temperature properties. The polymers should not be used with phenols, ketones, strong carboxylated acids, aromatic hydrocarbons and nitrogen derivatives.

Carboxylated nitrile rubber is normally used for its outstanding abrasion resistance especially in combination with butadiene rubbers.

Dependent on compounding techniques, nitrile rubber linings with similar physical properties to polyisoprene rubbers can be prepared suitable for use within the temperature range $-20\text{ }^{\circ}\text{C}$ to $+110\text{ }^{\circ}\text{C}$.

A.3.7 Polybutadiene rubber (BR)

Polybutadiene rubber is normally used in combination with polyisoprene or carboxylated nitrile rubber to produce linings with superior abrasion resistance compared to the individual rubbers and to improve the lower temperature properties of nitrile rubber.

A.3.8 Chlorosulphonated polyethylene rubber (CSM)

Chlorosulphonated polyethylene rubber is a synthetic polymer with excellent resistance to heat, ozone and oxidizing chemicals. It can be compounded for resistance to chemicals such as sodium hypochlorite solutions and high concentration sulphuric acid. It has good resistance to many oils, lubricants and aliphatic hydrocarbons but is unsuitable for use with esters, ketones, chlorinated solvents and aromatic hydrocarbons.

Chlorosulphonated polyethylene may be used for linings operating continuously within the temperature range $-5\text{ }^{\circ}\text{C}$ to $+105\text{ }^{\circ}\text{C}$.

A.4 Hard rubber and ebonite linings

A.4.1 Hard rubber linings are usually produced by incorporating higher levels of sulphur in the formulations, compared to those used in soft rubber linings. As the level of sulphur used is increased the percentage of the residual unsaturation in the polymer decreases thus producing a harder lining. When highly unsaturated rubbers are used with sulphur levels between 25 and 50 parts by weight per 100 parts by weight of rubber, then hard vulcanizates, commonly called ebonites, are formed. These ebonites can be produced from natural or synthetic polyisoprenes, styrene-butadiene, acrylonitrile-butadiene and polybutadiene rubbers and blends of those rubbers.

Some hard rubbers are produced with relatively low sulphur levels by the incorporation of various resins. When it is necessary to create flexible or impact-resistant ebonites then polymers with a limited liability to harden when vulcanized are added to formulations.

A.4.2 Hard rubbers and ebonites generally have a higher resistance to chemicals than soft rubbers based on the same polymer types. This resistance again generally increases with decrease in unsaturation of the vulcanized polymer. Resistance to chlorine gas and most aliphatic carboxylic acids is particularly improved.

A.4.3 Due to the increase in saturation when high levels of sulphur are used ebonites usually have a low elongation at break of 2 % to 10 %. Hence they are brittle compared to soft rubber lining materials at ambient temperatures. This brittleness can be reduced by using flexibilizing additives. Ebonites are thermoplastic materials.

Ebonites are normally used within the temperature range $0\text{ }^{\circ}\text{C}$ to $100\text{ }^{\circ}\text{C}$. For lower operating temperatures, ebonites modified with flexibilizers or non-ebonite hard rubbers are often used.

Appendix B Continuity testing**B.1 Introduction**

It is essential that linings provide adequate protection to equipment under the conditions for which they are designed. Therefore, there is a requirement that a lining is continuous, i.e. free from pinholes and cracks; tests which prove the continuity of the lining are necessary.

The approach to continuity testing is to consider the lining as an electrical insulator and search for holes by trying to make electrical contact to the substrate through the lining. There are two possible methods of searching:

- a) spark testing in which a discharge from a high frequency source or a direct current spark is used to find the fault;
- b) wet sponge testing which consists of a wet sponge soaked in an electrolyte as one probe of a low voltage circuit, the other being the earth return.

B.2 Spark testing

B.2.1 General

There are two types of spark testing equipment in general use:

- a) high frequency with an a.c. source;
- b) direct current (high voltage).

The mode of operation of the two types is quite different.

B.2.2 High frequency test equipment

In these instruments a Tesla coil is used to generate a high frequency discharge. Models are available which operate on supply voltages of 240 V, 110 V or 50 V. The voltages at which they discharge can be varied between 5 000 V and 50 000 V. Normally output is controlled but the actual output cannot be recorded on a meter. However, it is possible to measure the voltage for any set position of the control by the method laid down in BS 358, namely measuring the gap the spark will jump between 20 mm diameter spheres. The voltage of the discharge does vary but the peak voltage for any setting of the instrument will not be exceeded.

It is essential for proper testing that the spark length exceeds the length of any scarfed joint which a particular lining may contain. A practical and useful method of adjusting an instrument to the correct voltage for testing a lining is by one of the following methods.

- a) If possible place the probe(s) to be used for the inspection on top of the rubber in a part of the equipment where metal is exposed, e.g. a flange face with an unlined bolt hole. The distance between the probe(s) and the exposed metal should be 2 mm to 3 mm longer than the scarf joint length. With the probe(s) in this position adjust the voltage until the spark just bridges the gap.

- b) Where there is not a convenient position where the metal of the equipment is exposed then a similar procedure to a) should be employed using a steel plate placed on top of the rubber at the correct distance away from the probe(s). The thickness of the plate should be 3 mm and the size at least 75 mm × 150 mm. All edges and corners should have a radius of approximately 3 mm.

- c) There may be occasions when the lining and covering to a tube have to be tested and there is no metal exposed. In this case the setting up procedure should be similar to b) but using a piece of metal (rod or tube) inside the lined tube. The actual size and shape of this piece of metal should be agreed when the details of the inspection procedure are discussed. The radius of curvature of the ends of the rod or tube should be approximately 3 mm.

These methods of adjusting the test voltage have the advantage that loss of power of the discharge through the body of the rubber is taken into account.

These instruments have a single electrode. The form of the electrode should be chosen bearing in mind the size and contour of the surface to be tested. In the case of small areas with a complex contour a short, straight, pointed probe may be appropriate. When a large area such as a tank lining is to be surveyed it is useful to use an L-shaped electrode. The length of the leg which is used to cover the surface of the rubber should not exceed 150 mm. In the case of linings to pipes, the end of the electrode should be shaped to fit loosely the inside circumference of the pipe. The rods leading down the probe have to be insulated.

When the electrode is held on, or close to an insulating material there is a corona discharge. When an insulating material containing a fault is covering a substrate which is conducting then the discharge concentrates at that point and the fault is located. Some rubbers are compounded so that they have a much lower resistivity than those in common use. These rubbers are sometimes referred to as conducting rubbers. When a high frequency spark test is applied to such rubbers the nature of the discharge is different and will concentrate in such a way that it may be thought that the rubber contains faults. A very experienced operator can detect the difference, but nevertheless the use of such rubbers for lining equipment intended for corrosive duties is not recommended because of the difficulty in testing.

Tests have shown that the risk of damage to most rubber linings by high frequency spark testing is remote if the time the probe is allowed to dwell on any one place is short.

Breakdown of most linings by spark testing is by erosion until a critical thickness is reached. During the time that the surface is exposed to a spark in test conditions the material lost by spark erosion is negligible. However there are some rubbers which, because of the way they are compounded, can be damaged by the spark concentrating through to the carbon black, causing local burning of the rubber. Adequate testing of such linings is not possible and they should not be used for equipment intended for a corrosive duty.

B.2.2 Direct current spark testers

This type of instrument may be powered by mains or a rechargeable battery. The output voltage varies with the make but a common range is 1 000 V to 20 000 V. Most instruments do have a voltage control and a built-in voltmeter and this is the model recommended for use.

With d.c. instruments it is necessary to have an earth return. Unlike the high frequency instrument there is only a discharge when the electrode is close enough to a defect for the d.c. spark to bridge the gap to earth. The length of that gap is limited and is generally less than the length of the scarfed joints used in lining and therefore this type of instrument is unsuitable for testing rubber linings.

B.3 Wet sponge testing

In the case of rubber linings which are normally at least 3 mm thick and may contain scarf joints up to 32 mm in length wet sponge testing is not recommended. This is because the time that may be required for the electrolyte to penetrate the hole in the rubber, or a leak in a joint may be rather long. By the time the electrolyte reaches the substrate the probe may no longer be in a position to complete the circuit. Furthermore, in some cases when the rubber contains a cut it is possible the electrolyte will not penetrate that cut under the conditions of the test.

B.4 Testing

It is essential that inspectors have an understanding of how the instruments work and the need to survey the linings in a controlled fashion.

Because of the need to ensure that continuity testing is carried out to the required standard it is preferable that the test work is done by a person other than the operator(s) who applied the lining.

Appendix C Vulcanization

C.1 Rubbers are made up of long chain molecules. Within these molecules chemically active sites exist by means of which the chains can be interlinked. This process is known as vulcanization and the most common vulcanizing agent is sulphur.

C.2 Vulcanization is effected either by means of heat and pressure or by the application of heat alone (i.e. without pressure) or in the case of self-vulcanizing rubber compounds by allowing a sufficient period of time to elapse at ambient temperature.

C.3 Depending on the type of elastomer and formulation used elastic compositions of varying hardness may be obtained. If sufficient sulphur to substantially saturate the sites available for cross linking is added then ebonites are formed. These are very hard thermoplastic materials.

C.4 When heat is necessary to promote vulcanization and the size of the metal equipment permits, the use of an autoclave is to be preferred. Saturated steam or hot air normally within the temperature range 125 °C to 160 °C are usually employed as heat-transfer agents and the pressure can be up to 4.2 bar³⁾.

C.5 After loading the equipment to be vulcanized the autoclave is heated under pressure to the vulcanizing temperature. The rate of heating to the vulcanizing temperature and the time for which the latter is maintained depends upon the thickness of the lining, its formulation and the mass of the substrate.

C.6 Containers and equipment which because of transport difficulties or because of their dimensions cannot be vulcanized in an autoclave, are lined and vulcanized on site. Under such circumstances self-vulcanizing rubber formulations or pre-vulcanized rubber sheets may be used, but where these are not considered to be suitable the following methods of effecting vulcanization are available.

- a) Pressure vessels or others capable of withstanding pressure are normally vulcanized by the injection of saturated steam under pressure.
- b) Non-pressure vessels may be vulcanized with hot water, hot air or low pressure steam. When vulcanizing with low pressure steam, sudden changes of pressure should be avoided.

C.7 When vulcanizing on site, insulation or covering of the vessel is recommended, particularly in the event of low ambient temperatures. It should be noted that vulcanization times of one or more days will be required when the application of steam pressure is not possible. For self-vulcanizing compounds, vulcanization time may extend to several weeks at ambient temperature.

³⁾ 1 bar = 10⁵ N/m² = 10⁵ Pa.

C.8 It should be noted that the shelf life of the unvulcanized sheet will be shorter in the case of rapidly vulcanizing rubbers, self-vulcanizing compounds having the shortest storage lives. When high ambient temperatures are expected, refrigerated transport and storage of the sheet may be necessary. In the case of prevulcanized rubber sheet refrigerated transport and storage are not necessary, but it should be protected from direct sunlight.

Appendix D Lining of used equipment

D.1 Providing that previously used plant and equipment is structurally sound and that it has not been subjected to extensive corrosion, relining is normally possible. It is, however, particularly important that the lining contractor should inspect such items and agree that they are in a suitable condition for him to undertake the work.

D.2 When it is necessary to replace a rubber lining in existing equipment the old lining will have to be removed by one of the following methods.

a) *Burning*. Most rubbers may be removed by this procedure but although effective it is subject to certain disadvantages.

- 1) Metal structures may warp as a result of the heat generated.
- 2) Noxious or toxic fumes will be generated and in the case of ebonites and the essentially non-combustible polychloroprene these will be particularly objectionable and may constitute a health hazard.

It is essential therefore that care be taken to ensure that anti-pollution laws are not infringed by this procedure.

b) *Heating*. This is a more acceptable alternative to burning and involves raising the temperature by externally heating the equipment so that the bond to the metal is weakened. The heating process is followed by mechanical removal of the rubber.

c) *Mechanical removal*. The most effective method in instances where adhesion to the metal is still good is to cut through the rubber so that it is divided into narrow strips. These can then be most readily removed by application of a mechanical chisel to the rubber/metal interface.

D.3 After removal of the old lining the metal should be prepared in the normal way. Inspection to check the vessel's mechanical suitability for the duty should, if necessary, be also carried out at this stage.

D.4 When the old lining has been removed and inspection has confirmed that the item is mechanically sound and in a suitable condition for relining, the standard procedures outlined in this specification should be followed.

However, if there is any reason to suppose that there has been any impregnation of the metal by chemicals, it is sound practice to sweat the metal in live steam before shot-blasting.

Where noticeable corrosion has occurred relining should be avoided. However, linings can be applied when the surface to be protected is additionally pretreated, for example by grinding, neutralizing, flame descaling or annealing, but the user should be warned of the likely risks entailed in obtaining a satisfactory lining.

Appendix E Maintenance of rubber lined equipment

E.1 It is recommended that all rubber lined plant and equipment should be thoroughly inspected at the end of the first year of service. If its condition is satisfactory and it is not subject to statutory inspection after a lesser period some major users do not then inspect again for a further 5 years. Others prefer to inspect at more frequent intervals.

E.2 When carrying out inspections it is normally sufficient if these are visual, supplemented by hardness tests using a hand meter. If blisters or other evidence of failure are discovered then an electrical continuity test is essential.

E.3 It is essential that personnel be instructed in the proper procedures to be adopted when entering rubber-lined vessels. A clearance certificate should always be obtained from the appropriate authority before doing so. The following points should be observed.

- a) Personnel should not wear studded boots or other footwear likely to cause damage. Rubber-soled shoes are to be preferred.
- b) In cases where solid deposits have to be removed the use of metal spades or other tools is to be avoided. Wooden or lined implements should be used.
- c) The ends of ladders or scaffolding likely to come in contact with the rubber lining should be covered in such a way that damage is avoided. Swinging air lines or hoses can also puncture rubber linings. Metallic ends should therefore be covered to prevent this occurring.
- d) In large ebonite-lined vessels precautions to avoid successive flexing should be taken and walkways laid if necessary.

Inspection should always be carried out by two people unless the use of ladders or electrical equipment can be avoided.

Appendix F Effect of materials on water quality

When used under the conditions for which they are designed, materials in contact with or likely to come into contact with potable water shall not constitute a toxic hazard, shall not support microbial growth and shall not give rise to unpleasant taste or odour, cloudiness or discoloration of the water.

Concentrations of substances, chemicals and biological agents leached from materials in contact with potable water, and measurements of the relevant organoleptic/physical parameters shall not exceed the maximum values recommended by the World Health Organization in its publication "Guidelines for drinking water quality" Vol. 1 "Recommendations" (WHO, Geneva 1984) or as required by the EEC Council Directive of 15 July 1980 relating to the quality of water intended for human consumption (Official Journal of the European Communities L229 pp 11–29), whichever in each case is the more stringent.

NOTE 1 Requirements for the testing of non-metallic materials in these respects are set out in the UK Water Fittings Byelaws Scheme Information and Guidance Note No. 5-01-02, ISSN 0267-0313, obtainable from the Water Research Centre, Fittings Testing Station, 660 Ajax Avenue, Slough, Berkshire SL1 4BG.

NOTE 2 Requirements for the testing of metallic materials in these respects are set out in DD 82.

NOTE 3 Pending the determination of suitable means of characterizing the toxicity of leachates from materials in contact with potable water, materials approved by the Department of the Environment Committee on Chemicals and Materials of Construction for use in Public Water Supply and Swimming Pools are considered free from toxic hazard for the purposes of compliance with this appendix. A list of approved chemicals and materials is available from the Department of the Environment Water Division, Romney House, 43 Marsham Street, London SW1P 3PY.

NOTE 4 Products manufactured for installation and use in the United Kingdom which are verified and listed under the UK Water Fittings Byelaws Scheme administered by the Water Research Centre, (address as in note 1) are deemed to satisfy the requirements detailed in this appendix.

Publications referred to

BS 358, *Method for the measurement of voltage with sphere-gaps (one sphere earthed)*.

BS 470, *Specification for inspection, access and entry openings for pressure vessels*.

BS 903, *Methods of testing vulcanized rubber*.

BS 903-A21, *Determination of rubber-to-metal bond strength*.

BS 2035, *Cast iron flanged pipes and flanged fittings*.

BS 2719, *Methods of use and calibration of pocket type rubber hardness meters*.

BS 3558, *Glossary of rubber terms*.

BS 5337, *Code of practice for the structural use of concrete for retaining aqueous liquids*.

BS 8110, *The structural use of concrete⁴⁾*.

Swedish Standard SIS 05 5900 Pictorial surface preparation standards for painting steel surfaces.

⁴⁾ In preparation. Revision of CP 110.

BSI — British Standards Institution

BSI is the independent national body responsible for preparing British Standards. It presents the UK view on standards in Europe and at the international level. It is incorporated by Royal Charter.

Revisions

British Standards are updated by amendment or revision. Users of British Standards should make sure that they possess the latest amendments or editions.

It is the constant aim of BSI to improve the quality of our products and services. We would be grateful if anyone finding an inaccuracy or ambiguity while using this British Standard would inform the Secretary of the technical committee responsible, the identity of which can be found on the inside front cover. Tel: 020 8996 9000. Fax: 020 8996 7400.

BSI offers members an individual updating service called PLUS which ensures that subscribers automatically receive the latest editions of standards.

Buying standards

Orders for all BSI, international and foreign standards publications should be addressed to Customer Services. Tel: 020 8996 9001. Fax: 020 8996 7001.

In response to orders for international standards, it is BSI policy to supply the BSI implementation of those that have been published as British Standards, unless otherwise requested.

Information on standards

BSI provides a wide range of information on national, European and international standards through its Library and its Technical Help to Exporters Service. Various BSI electronic information services are also available which give details on all its products and services. Contact the Information Centre. Tel: 020 8996 7111. Fax: 020 8996 7048.

Subscribing members of BSI are kept up to date with standards developments and receive substantial discounts on the purchase price of standards. For details of these and other benefits contact Membership Administration. Tel: 020 8996 7002. Fax: 020 8996 7001.

Copyright

Copyright subsists in all BSI publications. BSI also holds the copyright, in the UK, of the publications of the international standardization bodies. Except as permitted under the Copyright, Designs and Patents Act 1988 no extract may be reproduced, stored in a retrieval system or transmitted in any form or by any means – electronic, photocopying, recording or otherwise – without prior written permission from BSI.

This does not preclude the free use, in the course of implementing the standard, of necessary details such as symbols, and size, type or grade designations. If these details are to be used for any other purpose than implementation then the prior written permission of BSI must be obtained.

If permission is granted, the terms may include royalty payments or a licensing agreement. Details and advice can be obtained from the Copyright Manager. Tel: 020 8996 7070.