

CONFIRMED
AUG 1993

Electric surface heating —

**Part 3: Code of practice for the
installation, testing and maintenance of
electric surface heating systems**

UDC 621.365.3/.4:669-408

Committees responsible for this British Standard

The preparation of this British Standard was entrusted by the Power Electrical Engineering Standards Committee (PEL/-) to Technical Committee PEL/87 upon which the following bodies were represented:

Association of Manufacturers Allied to the Electrical and Electronic Industry (BEAMA)

BCIRA

British Gas Corporation

British National Committee for Electroheat

British Steel Corporation

Committee for Electrical Equipment for use in Flammable Atmosphere (BEAMA)

Electricity Supply Industry in England and Wales

Energy Industries Council

Engineering Equipment and Materials Users' Association

Glass Manufacturers' Federation

Health and Safety Executive

Induction and Dielectric Heating Manufacturers' Association

Institution of Electrical Engineers

Lighting Industry Federation Ltd.

Ministry of Defence

This British Standard, having been prepared under the direction of the Power Electrical Engineering Standards Committee, was published under the authority of the Board of BSI and comes into effect on 30 November 1983

© BSI 02-1999

The following BSI references relate to the work on this standard:
Committee reference PEL/87
Draft for comment 78/29755 DC

ISBN 0 580 13612 4

Amendments issued since publication

Amd. No.	Date of issue	Comments

Contents

	Page
Committees responsible	Inside front cover
Foreword	ii
<hr/>	
0 Introduction	1
1 Scope	1
2 Definitions	1
3 Preparatory work	1
4 Installation of ESH devices	1
5 Control and monitoring	6
6 Thermal insulation	7
7 Inspection and testing	8
8 Modifications	11
9 Maintenance	11
10 Repairs	11
11 Labelling and identification	12
<hr/>	
Figure 1 — Mounting of junction boxes on pipework	13
Figure 2 — Single heating tape straight traced on pipework without fittings	14
Figure 3 — Double run of heating tape straight traced on pipework without fittings	14
Figure 4 — Triple run of heating tape straight traced (as for 3-phase)	14
Figure 5 — Routing at flanges to avoid leaks and mechanical damage	14
Figure 6 — Methods for tracing valves, strainers, etc.	15
Figure 7 — Tracing on branch lines	16
Figure 8 — Straight traced heating cables and cable units	17
Figure 9 — Method for cable tracing valves, etc.	18
<hr/>	
Table 1 — Pre-installation checks	2
<hr/>	
Publications referred to	Inside back cover
<hr/>	

Foreword

This Part of BS 6351 has been prepared under the direction of the Power Electrical Engineering Standards Committee.

BS 6351 consists of the following Parts:

- *Part 1: Specification for electric surface heating devices;*
- *Part 2: Guide to the design of electric surface heating systems;*
- *Part 3: Code of practice for the installation, testing and maintenance of electric surface heating systems.*

This Part should be read in conjunction with Parts 1 and 2 of BS 6351 and with the instructions and recommendations of the system designers and of the manufacturers of the equipment being installed.

A British Standard does not purport to include all the necessary provisions of a contract. Users of British Standards are responsible for their correct application.

Compliance with a British Standard does not of itself confer immunity from legal obligations¹⁾. In particular, attention is drawn to the following:

Health and Safety at Work etc. Act 1974

Factories Act 1961

Electricity (Factories Act) Special Regulations 1908 and 1944

Highly Flammable Liquids and Liquefied Petroleum Gases Regulations 1972

IEE Regulations for Electrical Installations

Summary of pages

This document comprises a front cover, an inside front cover, pages i and ii, pages 1 to 18, an inside back cover and a back cover.

This standard has been updated (see copyright date) and may have had amendments incorporated. This will be indicated in the amendment table on the inside front cover.

¹⁾ The designer, installer and user should make themselves aware of any legal or local regulations applying to the works or site.

0 Introduction

Electric surface heating (ESH) systems are designed to match the requirements of the process and plant. The ESH system comprises a number of components that are integrated on site and it is therefore necessary to ensure that the plant parameters used in the design are still valid when the ESH system is installed and that the components are installed correctly. Appropriate testing and maintenance are also essential to ensure satisfactory performance and safety.

1 Scope

This code of practice makes recommendations on installation procedures for ESH systems. It also covers the related topics of repair methods and inspection, maintenance and testing.

Recommendations are made additionally on wiring systems and the installation of thermal insulation.

It does not cover devices that operate by induction heating, immersion heating, skin-effect heating or direct pipeline heating, nor those intended for stress relieving.

Recommendations are given for use both in non-hazardous areas and in those hazardous areas (other than marine applications, mining applications or explosives processing and manufacture) classified as Zone 1 or Zone 2 in accordance with BS 5345. The scope of this code does not include areas classified as Zone 0 nor the heating of parts of vessels, etc. when they may have an internal Zone 0 classification.

NOTE The titles of the publications referred to in this code are listed on the inside back cover.

2 Definitions

For the purposes of this Part of BS 6351, the definitions given in BS 6351-1 apply.

3 Preparatory work

3.1 Personnel. All persons involved in the installation, testing and maintenance of electric surface heating systems should be suitably trained in any special techniques required, as well as in general electrical work. All work should be monitored by trained supervisors.

3.2 Pre-installation checks. Before starting installation work, the check list given in Table 1 should be used to determine whether the design matches the installation conditions.

It is essential that the work follow the design scheme, but no item listed should be allowed to pass unchecked.

3.3 Surface preparation. The surface to which the ESH device is to be fitted should be free from rust, grease, oil, etc. and any sharp protrusions such as weld spatter, cement splashes, etc. should be removed. All surfaces should be smooth and clean as far as is possible. Care should be taken to ensure that any coating or finish applied to the workpiece is suitable for the duty.

4 Installation of ESH devices

4.1 Recommendations for all types of ESH system

4.1.1 General. The aspects of installation procedure described in 4.1.2 to 4.1.11 are common to all types of ESH system and should be observed unless otherwise specified by the designer.

Recommendations for individual types of ESH device are given in 4.2 to 4.5.

4.1.2 Appropriateness of device. The details given on the label attached to the ESH device should be checked for compliance with the system documentation.

4.1.3 Terminations

4.1.3.1 General. It is essential that all types of surface heating equipment are terminated correctly. Manufacturer's specific instructions should be followed together with the general procedures described in 4.1.3.2 to 4.1.3.7.

4.1.3.2 Cold leads. Cold leads should be fitted or modified on site only in strict accordance with the manufacturer's recommendations. Any such work carried out on ESH devices used in hazardous areas will invalidate the certificate unless carried out strictly in accordance with specific instructions incorporated in the certificate schedule; the manufacturer of the ESH device should be consulted.

Where cold leads have been jointed to metal-sheathed heating cables by means of soldering or brazing, neither the heating cables nor the cold lead should be bent within 150 mm of the joint. Each cable should be fixed at a distance of 150 mm from the joint to prevent this.

NOTE In some instances it is not desirable to have a cold lead anchored to the heated surface because of the risk of exceeding the maximum recommended temperature for the cold lead.

Table 1 — Pre-installation checks

Items to be checked	Remarks
1. Is the pipework fully erected and tested and all temporary supports removed?	Any welding or pressure testing after the installation of an ESH device could damage the device
2. Is the surface to which the ESH device is to be applied normal steel?	If the surface is of polished stainless steel, very thin-walled pipe or plastic of any kind, then special precautions may be necessary
3. Do the items to be heated correspond in size, length, position, etc. with the design?	It is sometimes difficult to be sure that the correct pipe is being heated. BS 1710 could be of assistance, as could any other line numbering system
4. Has an inner cladding been specified to be installed before the application of the ESH device?	This may be used to provide an earth path and/or to aid heat distribution
5. Has an inner cladding been specified to be installed after the application of the ESH device?	This may be used to prevent lagging from surrounding the ESH device and so increasing its temperature
6. Can flow of product under normal or abnormal conditions reach temperatures greater than those that the ESH device can withstand?	This would normally be covered in the design stage; however, further discussion with staff at the plant may show that incorrect or out-of-date information has been used
7. Are the ESH system designer's working drawings or designs and the manufacturer's installation instructions available?	No change should be contemplated without reference to the ESH system designer, as careful calculations are necessary to ensure safe operation
8. Can pipe or surface expand and contract so as to cause stress on any part of the heating installation?	In this case precautions are necessary to avoid damage
9. Can sensors of temperature controllers be affected by outside influences?	An adjacent heating circuit could affect the sensor
10. Is the ESH device to be spiralled or snaked on to the pipework, according to the design?	
11. Are cold leads suitable for contact with the heated surface?	If the cold lead is to be buried under the lagging, it has to be able to withstand the temperature
12. Is pipework hung from a pipe rack?	In this case special precautions are required to ensure the weatherproofing of the lagging at points of suspension.
13. Does pipework have its full complement of supports?	The addition of intermediate supports at a later stage could damage the heating system
14. Are sample lines/bleed lines, etc. on plant but not on drawings?	These could obstruct or prevent the fitting of the ESH device and reference to the ESH system designer may be necessary
15. Are other parameters used in the design of the equipment as specified by the design documentation?	
16. Are the ESH devices, controllers, junction boxes, switches, cable, cable glands, etc., suitable for the hazardous area classification (if any) and the environmental conditions and are they protected as necessary against corrosion and the ingress of liquids and particulate matter?	

After site-fitting of cold leads, checks should be made to ensure that the joints have not affected continuity or insulation resistance, that joints are waterproof (where applicable) and that the earth connection across the joint is valid. Joints between cold leads and heating conductors should always be firmly anchored to the heated surface such that the hot cable cannot leave the surface to be heated. Cold leads should always emerge from the thermal insulation (where applied) in such a way that the resultant hole in the lagging cannot admit water or other contaminants. Excess lengths of cold leads may be distributed under the thermal insulation where construction and the manufacturer's instructions permit.

A check should be made to ensure that the cold leads can accommodate any movement of pipework resulting from expansion, contraction or vibration.

4.1.3.3 Junction boxes. ESH devices should be connected into junction boxes having a suitable degree or type of protection. Junction boxes should be located as closely as possible to the cold-lead exit point so that the length of cold lead vulnerable to mechanical damage will be a minimum. To achieve this, junction boxes, etc. can be mounted on the workpiece [see Figure 1(a)], provided that a thermal barrier is inserted between junction box and heated surface if indicated by the designer.

For outdoor applications, all junction boxes should be water and dust resistant and be mounted as shown in Figure 1(b). Lids should not be left open during the period of erection.

4.1.3.4 Cable entries and glands. ESH devices should be provided with seals and/or glands appropriate to the degree or type of protection. With threaded entries into the junction box, glands should be fully screwed into the box and compression applied to the cold leads or heating cable/tape to provide a complete seal. Unused entries should be blanked off with suitable plugs.

If unthreaded entries are used, the entry size should provide just sufficient clearance for the threaded section of the gland with the gland backnut tightened against a compressible sealing washer to seal the gland to the enclosure.

NOTE Requirements for dealing with unused entries in hazardous areas are given in BS 5501, BS 4683 and BS 5345.

4.1.3.5 Conductor terminations. Cold leads should be terminated in a safe and neat manner in the junction box or associated equipment. Terminals should be of sufficient size and rating to accept the conductors, which may be solid or stranded wires or foils. Care should be taken in stripping back insulation to avoid damaging the conductors.

Compression-type connectors or ferrules should be of the correct size and of an approved type for the conductor concerned. Compression tools should be of the ratchet type specific to the fittings used and be in good condition.

Cable ends that are not finally terminated immediately after cutting should be sealed to prevent ingress of moisture and should be protected from damage pending completion of the termination.

4.1.3.6 Earthing. Where an earth lead is fitted to an ESH device it should always be connected to an established earth terminal. (See CP 1013.)

In the case of braided and metal-sheathed cables and tapes, it may be necessary to earth at more than one point. Manufacturer's instructions should be observed. In a hazardous area, reference should be made to 22.6 of BS 5345-1:1976.

4.1.3.7 Jointing and splicing. Jointing and splicing may be done on site only in strict accordance with the manufacturer's recommendations. Any such work carried out on ESH devices used in hazardous areas will invalidate the certificate unless carried out strictly in accordance with specific instructions incorporated in the certificate schedule: the manufacturer of the ESH device should be consulted.

4.1.4 Electrical testing

4.1.4.1 General. ESH devices should be tested before installation for conductor continuity, unit resistance and, on units provided with a metallic covering, insulation resistance as described in 4.1.4.2 to 4.1.4.5.

4.1.4.2 Insulation resistance. The insulation resistance should be measured under normal dry conditions and before connection of the device to the associated wiring and control equipment by means of a d.c. voltage within the range 80 V to 500 V.

The insulation resistance should be not less than 0.1 MΩ km.

4.1.4.3 Unit resistance. The unit resistance of the device should be within the declared tolerance except for ESH devices with self-limiting characteristics.

NOTE For self-limiting ESH devices the resistance can vary considerably without affecting the operation of the device. A tolerance, related to the ambient temperature, for the circuit resistance of self-limiting ESH devices should be stated by the designer to allow a site material quality control check to be made.

4.1.4.4 Repetition of testing procedures. Tests should be repeated after installation of the ESH devices and again after the application of thermal insulation including any protection applied by surface treatment or the fixing of cladding. If a metal surface is to be in contact with the ESH devices after installation, insulation resistance tests should be made as described for units with a metallic covering.

4.1.4.5 Test report. All test results obtained in 4.1.4.1, 4.1.4.2, 4.1.4.3 and 4.1.4.4 should be recorded in the system documentation for future reference.

4.1.5 Thermal contact. Where an ESH device is designed to be in contact with the surface to be heated, it should be installed to provide as intimate a contact as is reasonably practicable, avoiding air gaps that may create hot spots and avoiding encapsulation by thermal insulation. Where such contact is not possible, the designer should specify appropriate measures to provide a suitable heat sink, e.g. metal bridge pieces across obstructions or application of thermally conducting materials.

4.1.6 Laying. ESH devices should not be folded, twisted or allowed to cross, overlap or touch, as this could create hot spots.

NOTE This precaution may not be necessary with devices having self-limiting characteristics if it has been allowed by the design.

4.1.7 Fixing. ESH devices should be affixed to the workpiece by a means approved by the manufacturer such that the possibility of damage is minimized. Fixing materials should be suitable for the temperature and environmental conditions.

4.1.8 Protection from leaks. Where ESH devices cross possible sources of liquid leaks, for example flanges, they should be positioned to minimize contact with the leaking medium.

4.1.9 Modifications. ESH devices should not be modified on site other than by agreement with the designer.

4.1.10 Damage prevention. Precautions should be taken with all ESH devices to prevent damage prior to the application of thermal insulation. The installer should liaise with the lagging contractor (where applicable) to ensure that thermal insulation is applied as soon as possible after installation of the ESH devices. Where lagging is not provided, the ESH devices should be protected to avoid the possibility of mechanical damage and hazard to personnel.

4.1.11 Labelling. On completion of the installation, all labels should be firmly fixed to the appropriate items of apparatus and contain the correct information in accordance with clause 11.

Particular care is necessary in this respect in the case of site-fabricated ESH devices.

Labels should be fixed on the cold leads of devices at all power supply points and to both sides of any series connection points.

All junction boxes, controls, isolators, etc. should be clearly marked indicating to which circuits they relate.

Where thermal insulation is to be applied by others, warning labels should be given to the client/lagging contractor for application in prominent positions over the thermal insulation/cladding. Any identification labels required should also be handed into safe keeping with clear instructions for fixing.

4.2 Heating tapes and heating tape units

4.2.1 General. In addition to the general points in 4.1, the points given in 4.2.2 to 4.2.9 should be observed when installing heating tapes or heating tape units.

4.2.2 Spiral application

NOTE 1 Where tapes are intended for spiral application to the pipework, the approximate pitch of the spiral will have been specified at the design stage.

NOTE 2 The relationship between spiral pitch and the ratio of nett tape length to nett pipe length is given in Appendix B of BS 6351-2:1983.

Spiral pitch markings should be made on the pipework before applying the tape in a uniform spiral, starting at the power supply point and maintaining slight tension in the tape as it is applied. If at the end of the section to be heated, excess or insufficient tape exists, the spiral pitch should be lengthened or shortened to retain a uniform spiral whilst maintaining good contact between pipe and tape and remaining in general accordance with the design documentation. In no circumstances should the spacing be less than the minimum declared by the manufacturer.

4.2.3 Straight tracing. Where tapes are intended for straight tracing on horizontal pipework, they should be applied as shown in Figure 2, Figure 3 and Figure 4. On vertical pipework the tapes should be spaced equally around the pipe.

NOTE Excess tape at the end of a section to be heated may be re-apportioned in agreement with the designer by spiralling or snaking.

4.2.4 Fixing. The heating tape should be fixed to the pipework at intervals not exceeding 2 000 mm for spiral application and 300 mm for straight traced application. Additional fixings should be applied at bends, flanges and other obstructions to maintain contact with the workpiece.

4.2.5 Routing at fittings. Care should be taken at flanges, valves and other fittings to ensure that the heating tape will not be damaged by sharp edges and that the crossing point is located so as to avoid any leakage that may occur in service (see Figure 5).

NOTE The use of bridging pieces may have been specified at such points.

4.2.6 Additional heat loss compensation at fittings. Lengths of heating tape will have been allowed for in the design to compensate for additional heat losses at large valves, filters, strainers, etc. These lengths should be applied either in a spiral fashion over the fitting, following the contours of the body to ensure good contact [Figure 6(a)], or by closely spiralling the appropriate length of heating tape onto the pipework immediately before and after the fitting [Figure 6(b)].

NOTE In either case the direction of the helix may be reversed after the fitting to facilitate its removal. This may also be achieved by series connections of the heating tape at either side of the fitting or by the provision of a separate heater [Figure 6(c)].

4.2.7 T-branches. The design should be followed with respect to T-branches in the pipework.

NOTE The designer may have indicated double tracing, if this would not produce an unbalanced heat input, or a separate heating tape unit [see Figure 7(a) and Figure 7(b)].

4.2.8 Site-terminated devices. Where series resistance heating tapes are designed for site termination, it should be ensured that installed tape lengths correspond to the design lengths and consequently the designed electrical loadings. Where site-terminated parallel-circuit heating tapes are employed, the total circuit lengths should not exceed the manufacturer's recommendations.

4.2.9 Tape with preferred contact side. Where a heating tape is constructed so that one particular side is designed for contact with the pipe, the heating tape should not be reversed.

4.3 Heating cables and heating cable units

4.3.1 General. In addition to the general points in 4.1, the points given in 4.3.2 to 4.3.8 should be observed when installing heating cables or heating cable units.

4.3.2 Spiral application

NOTE 1 Where cables are intended for spiral application to the pipework, the approximate pitch of the spiral will have been indicated at the design stage.

NOTE 2 The relationship between spiral pitch and the ratio of nett cable length to nett pipe length is given in Appendix B of BS 6351-2:1983.

Spiral pitch markings should be made on the pipework before applying the cable in a uniform spiral, starting at the power supply point and maintaining slight tension in the cable as it is applied. If at the end of the section to be heated, excess or insufficient cable exists, the spiral pitch should be lengthened or shortened to retain a uniform spiral whilst maintaining good contact between pipe and cable and remaining in general accordance with the design documentation. In no circumstances should the spacing be less than the minimum declared by the manufacturer.

4.3.3 Straight tracing. Where cables are intended for straight tracing of horizontal pipework, they should be applied as shown in Figure 8. On vertical pipework the cables should be spaced equally around the pipe.

NOTE Excess cable at the end of a section to be heated may be re-apportioned, by agreement with the designer, by spiralling or snaking.

4.3.4 Fixing. The heating cable should be fixed to the pipework at intervals not exceeding 2 000 mm for spiralled application and 300 mm for straight traced application. Additional fixings should be applied at bends, flanges and other obstructions to maintain contact with the workpiece.

4.3.5 Routing at fittings. Care should be taken at flanges, valves and other fittings to ensure that the heating cable will not be damaged by sharp edges and that the crossing point is located to avoid any leakage that may occur in service (see Figure 5).

NOTE The use of bridging pieces may have been indicated.

The cable should not be bent to a smaller radius than that recommended by the manufacturer.

4.3.6 Additional heat loss compensation at fittings. Lengths of heating cable will have been allowed for in the design to compensate for additional heat losses at large valves, filters, strainers, etc. These lengths should be applied either by snaking as in Figure 9, or in a spiral fashion over the fitting, following the contours of the body to ensure good contact [see Figure 6(a)], or by closely spiralling the appropriate length of heating cable onto the pipework immediately before and after the fitting [see Figure 6(b)].

NOTE In either case the direction of the helix may be reversed after the fitting to facilitate its removal. This may also be achieved by series connections of the heating cable at either side of the fitting or the provision of a separate heater [see Figure 6(c)].

4.3.7 T-branches The design should be followed with respect to T-branches in the pipework.

NOTE The designer may have indicated double tracing, if this would not produce an unbalanced heat input, or a separate heating cable unit [see Figure 7(a) and Figure 7(b)].

4.3.8 Site-terminated devices. Where series resistance heating cables are designed for site termination, it should be ensured that installed cable lengths correspond to the design lengths and consequently the designed electrical loadings. Where site-terminated parallel-circuit heating cables are employed, the total circuit lengths should not exceed the manufacturer's recommendations.

4.4 Flexible surface heater units

4.4.1 General. In addition to the general points in 4.1, the points given in 4.4.2 to 4.4.4 should be observed when installing flexible surface heater units.

4.4.2 Thermal contact. Where the flexible surface heater unit is designed for surface contact with the workpiece, the means of fixing should provide the necessary contact over the whole area of the unit.

4.4.3 Metal straps. Metal fixing bands or straps should not be used other than for flexible surface heater units comprising metal-sheathed cables within a flexible carrier. In such cases, extreme care is required to ensure that metal straps are not overtightened, tightening being only just sufficient to maintain contact with the surface to be heated.

4.4.4 Partial heating. Where the surface heater unit is not intended to cover the whole of the body to be heated, its positioning should conform with the drawing provided by the designer.

4.5 Rigid surface heater units

4.5.1 General. In addition to the general points in 4.1, the points given in 4.5.2 to 4.5.5 should be observed when installing rigid surface heater units.

4.5.2 Surface contact. Where the rigid surface heater unit is designed for surface contact with the workpiece, the means of fixing should provide the necessary contact over the whole area to be heated.

4.5.3 Support. Where means of support are required, such means should be adequate to support the weight of the surface heater and retain it in position without transmitting vibration.

4.5.4 Partial heating. Where a rigid surface heater unit is not intended to cover the whole of the body to be heated, positioning should conform with the drawing provided by the designer.

4.5.5 Air gap. Where a metal-clad rigid surface heater unit is designed such that an air gap exists between the heat-emitting surface and the surface of the body to be heated, it should be ensured that as far as reasonably practicable the air gap is constant at all points.

5 Control and monitoring

5.1 Recommendations for all types of ESH system

5.1.1 General. Minimum control requirements covering overcurrent protection, residual current protection, isolation and temperature limitation set out in 3.3 of BS 6351-2:1983 should be complied with, as should any additional requirements for particular applications indicated by the designer.

The general installation recommendations given in 5.1.2 and 5.1.3 should always be complied with. Further recommendations for individual items of equipment are given in 5.2 and 5.3.

5.1.2 Contactor current ratings. It should always be ensured that current ratings of switch contacts are not exceeded, contactors of suitable rating being employed where necessary. Inrush current may be higher than normal operating current, particularly with self-limiting types of ESH device.

5.1.3 Environmental protection. Enclosures should be weatherproof and/or dustproof as necessitated by the environment in accordance with BS 5420 and BS 5490, and if in a hazardous area, should comply with the requirements of BS 5345.

5.2 Temperature limitation

NOTE In order to limit the temperature of an ESH device to a safe level, limitation of the temperature of the surface to be heated is a design pre-condition. Where the heating duty is such that a stabilized design is not possible, ESH temperature controllers will have been incorporated in the design.

5.2.1 Surface temperature controllers

NOTE Surface temperature controllers are of two main types:

- a) capillary devices;
- b) solid-state controllers with thermocouple or resistance bulb sensors.

5.2.1.1 In all cases it is essential that the sensor is positioned in accordance with the designer's instructions.

NOTE This will ensure that the sensor senses appropriate temperature conditions within the heating zone. For example, where flow and static conditions occur within one heating zone the sensor will probably be sited at a point of no flow and away from the end of the pipe or a heat sink such as a pipe support.

5.2.1.2 The temperature sensor should be strapped in good thermal contact with the workpiece and protected so that lagging materials cannot become trapped between it and the heated surface. Fixing materials indicated by the designer should be used and it is essential that care be taken not to distort the sensor, causing a calibration error.

5.2.1.3 Care should be taken to minimize the risk of damage to capillary tubes or thermocouple cables. Excess capillary tube may be run under the thermal insulation unless the length of tube is more than 1 m, in which case the volume of the capillary may be sufficient to affect the calibration to an unacceptable degree.

5.2.1.4 Care should be taken to ensure that the capillary tube or thermocouple cable emerges from the thermal insulation in a manner that will not allow the ingress of moisture.

5.2.1.5 The controller housing should be sited adjacent to the sensor position on a suitable pipe- or wall-mounted bracket. The controller should be set to the required temperature and re-calibrated if necessary. A functional check should be made by rotating the adjustment spindle until the controller is seen to operate via a meter. "Break on rise" devices will not operate at ambient temperature if this is below the minimum calibration point and the on/off switch, if fitted, should be checked with a meter.

Unless installed in a suitably explosion-protected enclosure, a solid-state temperature controller should be sited outside any hazardous area and form, together with intrinsically safe apparatus within the hazardous area, an intrinsically safe system. (See BS 5345-4.)

5.2.2 *Air sensing thermostats.* Air sensing thermostats should be sited in the most exposed position for the installation. For frost protection systems a temperature setting of 6 °C is recommended to allow for thermostat tolerance.

NOTE Air sensing thermostats do not relate to surface or heater temperatures but may be used together with surface temperature controllers.

5.2.3 *Process temperature controllers.* If additional temperature controllers are indicated for process reasons, the sensors should be surface-mounted or located in thermowells sited at suitable positions, e.g. above sludge levels in vessels as indicated in the design.

5.2.4 *Other temperature controllers.* Where a temperature controller is fitted as part of an ESH device, such as a surface heater unit, the actual setting necessary should be found experimentally on site.

5.3 Other equipment. All other equipment should be installed and checked in accordance with the instructions provided.

6 Thermal insulation

6.1 General

NOTE The thermal insulation system is an integral part of an ESH system, and design guidance is given in clause 4 of BS 6351-2:1983.

Installation should comply with BS 5970 and BS 5422 unless otherwise specified. Specified thermal insulation for temperatures above 230 °C should be non-combustible as defined by the test described in BS 476-4 whilst for temperatures below 230 °C performance P as designated in BS 476-5:1979 as amended by Amendment No. 1 should be applied unless there are special circumstances.

It is recommended that each section of plant to which ESH has been applied should be insulated immediately that section is completed and tested so that the thermal insulation provides mechanical protection for the installed ESH equipment.

Where weatherproof thermal insulation systems are involved, or where the pipework is installed in a potentially damp situation, temporary weather protection should be provided at the end of each working day.

NOTE This will avoid the risk of moisture being trapped in the thermal insulation beneath its final weather-protective coating.

6.2 Preparatory work

6.2.1 Before starting the installation of any electric surface heating system, it is recommended that site engineering liaison is established between the ESH installer and the thermal insulation contractor.

6.2.2 Any removal of existing thermal insulation should be executed in accordance with current statutory and local regulations before any ESH system is applied. Responsibility for cleaning, painting or other treatment of exposed surfaces should be agreed between the relevant parties.

6.2.3 The ESH installer should check that the thermal insulation is of the type specified for the project and is in accordance with the detailed ESH design.

6.2.4 Installation of thermal insulation should not proceed until the ESH system or the appropriate part thereof has been inspected and declared satisfactory.

6.3 Installation of thermal insulation

6.3.1 Thermal insulation should be applied to all sections of the pipework system, including flanges, valves, bends, T-junctions, etc. If expansion bellows are installed in the system, provision should be made to insulate these in such a manner that it does not impair the thermal efficiency of the ESH system, for example by half jackets fitted with an insulated running sleeve.

Preformed sections should be checked for diameter to ensure that they will adequately cover the pipework and the ESH system. Oversized sections may be required to compensate for the thickness of the ESH device, particularly if heavy-duty cables are indicated on small diameter pipework. Gaps at the joints between the sections should be filled with loose material or thin sections.

The thermal insulation should be applied in such a manner that no gaps occur between individual sections of thermal insulation. The recommended technique for installing preformed sections of pipe lagging is that the division between the two sections should occur in the horizontal plane and not the vertical plane. If two concentric layers of insulation are specified, the joints should be staggered.

NOTE Non-metallic materials are preferred for fixing sections, but if wire is used care has to be taken not to fix at or near the joint between adjacent sections.

6.3.2 Where there is a possibility of small leaks occurring in a pipework system, e.g. at flanges, pumps or valves, provision should be made to ensure that any leaking material can drain from outlets provided at the lowest point of the thermal insulation to avoid the progressive build-up of liquid.

6.4 Cladding

6.4.1 Where metal cladding is specified particular care should be taken to ensure that bare edges of metalwork cannot come into direct contact with the electric surface heating device.

Areas of greatest risk are as follows.

- a) *Flanges*. Metalwork should be cut back and the exposed face of the insulation finished with a suitable non-absorbent compound.
- b) *Valves*. A preformed insulating jacket is normally specified that should be overlength and carried on the adjacent pipework cladding.
- c) *Bends or tees*. Care should be taken not to force the adjacent straight pipe section of cladding into the bend with the probable risk of damage to an ESH device.

6.4.2 Bands with rolled-edge interlocking sections are preferred for fixing, but where it is necessary to drill through the cladding for the purpose of riveting or the fitting of self-tapping screws, it should be ensured that any drills or screws used are of insufficient length to penetrate through the thickness of thermal insulation.

7 Inspection and testing

7.1 General. Inspection should be carried out at the following times:

- a) throughout the installation programme; and

- b) as soon as possible after the completion of installation and before the precommissioning test procedure (see 7.5) is carried out prior to the connection of the ESH system to the electrical power supply.

NOTE Correct functional operation does not of itself indicate compliance with the recommendations for the safe use of apparatus.

A system should be established to record the results of all inspections. *This record* should be passed to the user/occupier of the plant as *part of the system documentation*.

7.2 Safety

7.2.1 Electrical safety

7.2.1.1 Whenever it is necessary to remove cladding and thermal insulation, it is recommended that electrical supplies to any type of ESH installation in the working area should first be isolated securely.

7.2.1.2 Work on an ESH installation should be performed only by personnel, as defined in 3.1, capable of taking the necessary measures to prevent danger. These measures should normally include secure isolation of the electrical supplies to the appropriate part of the ESH installation.

7.2.1.3 Before an ESH installation is re-commissioned after repairs to pipelines, vessels, the ESH devices themselves or thermal insulation or cladding, the electrical integrity of the installation should be verified and recorded.

7.2.2 Safety with particular reference to hazardous areas

7.2.2.1 Inspection and testing of the ESH system should be in accordance with section four of BS 5345-1:1976 and any other relevant Parts.

Authorization to work on a system that is installed in a hazardous area should be on a "Permit to work" basis whenever practicable, with the permit being signed by the person responsible for ensuring that the area is safe.

7.2.2.2 No apparatus enclosed in a hazardous area should be opened until it has been disconnected from its source of supply and until effective measures such as locking of the isolating switch in the open position have been taken to prevent its being made live before reassembly.

Where for purposes of electrical testing or fault finding it is essential to restore the supply before the apparatus is reassembled, special dispensation should be authorized by the issue of a "gas-free" certificate.

For testing intrinsically safe equipment, the requirements of BS 5345-4 should be complied with.

7.2.2.3 In a hazardous area, no operation such as brazing or soldering that requires the use of an open flame or other source of ignition or temperatures greater than those of the T class of the area as defined in BS 5345-1 should be attempted until the area has been made safe and a “gas-free” certificate issued.

7.3 Inspection during installation

7.3.1 Inspection should be carried out at all stages of the installation programme by an adequately trained supervisor. The check list given in **7.3.2** to **7.3.17** should prove useful in identifying possible problems and their causes. If a problem cannot be resolved by these checks, reference should be made to the ESH system designer.

7.3.2 If the heating cable or tape unit appears to be of incorrect length:

- a) pipework may not be in accordance with design;
- b) spiral ratio may have been incorrectly applied;
- c) allowances for fittings may have been incorrectly applied.

7.3.3 If the surface heater unit appears to be of incorrect size:

- a) workpiece may not be in accordance with design;
- b) spiral ratio may have been incorrectly applied.

7.3.4 If the heating cable or tape unit is twisted:

- a) the heating cable or tape unit may have been incorrectly applied.

7.3.5 If the heating cable or tape unit is without uniform spiral:

- a) the heating cable or tape unit may have been incorrectly applied;
- b) variable pitch may have been specified for different diameters;
- c) variable pitch may have been specified for increased heat input at fittings;
- d) the spiral may have been reversed either side of fittings for ease of removal.

7.3.6 If the ESH device is not in good contact with the workpiece:

- a) it may have been inadequately fixed;
- b) too long an interval may have elapsed before fitting the thermal insulation;
- c) “wind” stretch may have occurred;
- d) an air gap may have been indicated in the design.

7.3.7 If the ESH device is damaged:

- a) incorrect fixing materials may have been used;
- b) fixings may be overtight;

- c) there may have been wind damage;
- d) there may have been mechanical damage (e.g. from pipe supports or cladding);
- e) vandalism is a possibility.

7.3.8 If the cold lead appears to be of incorrect length:

- a) the junction box may have been mounted incorrectly;
- b) the ESH device may have been incorrectly applied.

7.3.9 If there is excess cold lead outside the thermal insulation:

- a) the ESH device may have been incorrectly applied;
- b) joint between cold lead and heating conductor may have been strained;
- c) there may have been mechanical damage;
- d) vandalism is a possibility.

7.3.10 If the junction box lids are missing or loose:

- a) circuit may be in process of being installed or checked;
- b) negligence is a possibility;
- c) vandalism is a possibility.

7.3.11 If the thermostat capillary is mounted on the workpiece:

- a) it may have been incorrectly installed;
- b) may have been specified in the design to provide mechanical protection.

7.3.12 If the temperature controller does not operate when the adjustment spindle is rotated:

- a) it may have been incorrectly calibrated;
- b) the minimum calibration may be above the prevailing condition;
- c) capillary or sensor may have been damaged;
- d) instrument failure may be indicated;
- e) vandalism is a possibility.

7.3.13 If the ESH device appears to be open circuit:

- a) there may be no connection to terminal block;
- b) there may be a faulty joint;
- c) there may have been mechanical damage;
- d) vandalism is a possibility.

7.3.14 If the ESH device appears to have a short circuit:

- a) there may have been incorrect site fabrication of parallel-circuit ESH device by connecting buswires together;
- b) there may have been mechanical damage;
- c) vandalism is a possibility.

7.3.15 If the ESH device resistance appears to be incorrect:

- a) incorrect ESH device may have been used;
- b) it may be a permitted site modification;
- c) a repair may have been incorrectly carried out;
- d) there may have been mechanical damage;
- e) vandalism is a possibility.

7.3.16 If the circuit resistance appears to be incorrect:

- a) the interwiring may have been incorrectly carried out;
- b) the ESH device may have been incorrectly connected;
- c) it may be a permitted site modification;
- d) circuit identification may be incorrect;
- e) there may have been mechanical damage;
- f) vandalism is a possibility.

7.3.17 If the insulation resistance appears to be too low:

- a) there may have been mechanical damage;
- b) there may be residual dampness;
- c) there may be water penetration into joints;
- d) there may be water penetration into junction boxes, etc.;
- e) there may be faulty interwiring or equipment.

7.4 Inspection on completion of installation.

Inspection of the completed installation should be carried out prior to the precommissioning test procedure (see 7.5) by a person appointed for the purpose.

The following points should be checked.

- a) Drawings should be available showing the as-installed configuration of the heating system.
- b) All components of the system should be as indicated by the design and should bear the correct circuit references.
- c) Any equipment installed within a hazardous area should be suitable for the area classification.
- d) Line identification labels if required should be in position and in good order.
- e) Junction box lids and other covers should be secure and water should not have ingressed.
- f) Supply and interwiring cables should be correct and in good order.
- g) Any temperature sensors should be correctly and securely positioned.
- h) Any temperature settings should be correct.
- i) There should be no unauthorized modifications.

NOTE For hazardous areas any change to certified apparatus may invalidate the certificate.

j) Electrical protection should be in accordance with the design.

k) Thermal insulation and cladding should be intact throughout and, where required by design, should be sealed against the ingress of water.

l) Drain holes should be provided at points where leakage may occur.

7.5 Precommissioning test

7.5.1 General. Before any part of an ESH system is energized by connection to the electrical power supply, the test procedure given in 7.5.2 and 7.5.3 should be carried out and the results *recorded as part of the system documentation*.

Part of the ESH system may be within a hazardous area that is not “gas-free”. If this is so, any testing should be in accordance with the conditions recommended in 7.2.2.

7.5.2 Conductor and insulation resistance. The conductor resistance of each ESH device and the insulation resistance to earth should be measured in accordance with, and have the values given in, 4.1.4.

Test voltages should be such that no damage is caused to any component of the system.

If long heating cable or tape units or surface heater units are not connected to the supply circuit immediately after completion of insulation resistance tests, the heating conductors should be solidly connected to earth to avoid any build-up in potential.

7.5.3 Earth loop impedance. Earth loop impedance measurements should be made as described in the latest edition of the IEE Regulations for Electrical Installations²⁾. Earth loop impedance measurement should be carried out at a current of at least 15 A. Neutral-earth loop impedance tests should be used except with protective multiple earthing systems.

7.6 Commissioning test procedure. After inspection and the precommissioning test procedure have been carried out, the ESH system should be connected to the electrical power supply. At this time, tests should be carried out on all residual current circuit breakers as described in the latest edition of the IEE Regulations for Electrical installations.

Readings of all ammeters, if fitted, should be noted at the time of initial energization of the circuits and again when the readings have stabilized.

All results should be recorded to form part of the system documentation.

²⁾ Available from the Institution of Electrical Engineers, Savoy Place, London WC2.

A certificate of completion should be issued on commissioning, making reference to this standard.

8 Modifications

8.1 General. Following any modification of the ESH system, for example arising from plant or process changes, those parts of the installation that have been disturbed should be checked in accordance with clause 7. The modification should be *recorded in the system documentation*.

8.2 Hazardous areas. If at any time there is a change in a hazardous area classification or in the characteristics of any flammable material present in the area, a check should be made to ensure that the ESH system meets the changed requirements. If an apparatus is moved from one location to another, a check should be made to ensure that it is suitable for use in the new location. All changes should be *recorded in the system documentation*.

9 Maintenance

9.1 General. It is recommended that the inspection schedule given in 7.4 should be carried out at intervals not exceeding two years. More frequent and/or more detailed inspection may be necessary in corrosive or other hostile environments or where there is a high risk of mechanical damage. The need for more frequent inspection should be determined by operational experience and by consultation with the user/occupier of the plant.

Maintenance of switchgear associated with electric surface heating is fully covered by BS 5405 and the recommendations therein should be followed.

All maintenance activities should be recorded in the system documentation.

9.2 Safety. The recommendations made in 7.2 should be followed and, for hazardous areas, reference should be made to the relevant parts of BS 5345.

9.3 Fault location. Specialized methods of fault location are necessary to find faults in ESH systems covered by thermal insulation and metallic cladding and advice should be sought from the ESH system designer.

A brief outline of the steps that may be necessary is given below.

- a) The exact layout of the ESH system should be determined from the system documentation.

If this proves inadequate, an "induction" instrument operating at approximately 1 000 Hz should be used to inject a signal into the ESH device and the route of the device followed by the audible signal obtained from the instrument.

- b) The type of fault should be determined, e.g. open circuit or leakage to earth.

- c) If there is an open circuit or low resistance to earth of less than say 500 Ω , a pulse echo or reflection instrument can be used with a considerable degree of success. Other faults should be traced using a bridge-type instrument employing a "Murray loop test" or variation thereof.

9.4 Fault rectification. Having located the fault, the defective component should be replaced or repaired in accordance with clause 10. Those parts of the installation that have been disturbed should be checked in accordance with clause 7.

10 Repairs

10.1 General

NOTE When a fault occurs in an ESH system it is necessary first to determine the cause. Most faults are caused by mechanical damage, corrosion, overheating or ingress of moisture.

Only when the cause has been eliminated should the defects be rectified by site repair or replacement. Site repair should be carried out only if the following conditions are satisfied.

- a) The repaired component will perform its designated function without undue change in electrical characteristic.
- b) Design and construction characteristics of the component are maintained, e.g. mechanical strength and water resistance.
- c) A method of repair is recommended by the ESH system designer and any special materials and tools are specified by him.
- d) No local hazard will be created in carrying out the repair.
- e) It does not invalidate the certificate for certified apparatus. Any repairs to certified apparatus used in hazardous areas should be strictly in accordance with any specific instructions incorporated in the certificate schedule; the ESH system designer should be consulted.

Where the above conditions cannot be met, a replacement component should be fitted.

10.2 Safety. The guidance given in 7.2 should be followed and, for hazardous areas, reference should be made to the relevant parts of BS 5345.

10.3 Practicability of repair of ESH devices

10.3.1 Mechanical damage

NOTE If the device has not been previously energized and mechanical damage has resulted in breakdown in electrical insulation, severed conductors or ingress of moisture, repair should normally be possible.

If the fault is found only after electrical connection and the damage is confined to a small area, visual inspection of the heating unit for 1 m on either side of the fault should be carried out to show whether the electrical insulation is affected other than at the point of mechanical damage.

10.3.2 Damage due to corrosion

NOTE Where breakdown results from corrosive action and the damage is limited to a small area, a repair should normally be possible.

If the ESH device has been damaged at more than one point or the damaged area is extensive, the ESH device should be replaced.

If the cause of corrosion cannot be removed, the device should be replaced by one capable of withstanding the corrosive effects, or be re-routed.

10.3.3 Damage due to overheating. Repairs should be carried out only when damage is limited to a small area. If a system design fault is suspected, the ESH system designer should be consulted.

10.4 Repair techniques for ESH devices

10.4.1 General

NOTE Techniques employed in the repair of ESH devices will vary with the type of device and its manufacturer. It is therefore outside the scope of this standard to detail actual methods.

Generally the repair of an ESH device will take the form of an in-line splice or a series connection via a junction box.

General procedures that should be adopted are given in 10.4.2 and 10.4.3. However, only those methods recommended by the manufacturer should be adopted and only materials or tools recommended by the manufacturer should be used.

10.4.2 In-line splice. The removal of a damaged section of heating conductor should not alter the resistance of the ESH device to a value differing by more than 5 % from its original design value. If an in-line splice is to operate at elevated temperatures, care should be taken to ensure that the repaired joint will not be subjected to stresses in operation, e.g. by providing an expansion loop on either side of the joint. The section 150 mm on either side of the joint should not be bent when re-applied to the workpiece and good contact should be ensured.

10.4.3 Series connection via junction box. The repair should not alter the resistance of the ESH device to a value differing by more than 5 % from its original design value. Where cold leads are applied to the ends of the severed heating conductors, the ESH device and repair joints should be firmly reattached to the workpiece to ensure good contact. Fitting of cold leads and terminations into the junction box should be in accordance with 4.1.3.

10.5 Earthing. Where ESH devices are earthed by means of a metal braid, metal sheath or foil screen, the integrity and continuity of the earth should not be impaired by the repair.

10.6 Testing

10.6.1 The repaired ESH device should be subjected to the tests described in 10.6.2 to 10.6.5 before reinstallation.

10.6.2 An ESH device having a high degree of water resistance, as indicated in the grade by the first characteristic numeral 2³⁾, should have the repaired section immersed in water for 1 h after which the insulation resistance of the ESH device should be measured by means of a d.c. voltage within the range 80 V to 500 V. The insulation resistance should be not less than 0.1 MΩ km.

10.6.3 An ESH device having a medium degree of water resistance, as indicated in the grade by the first characteristic numeral 1³⁾, should have the repaired section wetted by means of a sponge or cloth and then be subjected to the test described in 10.6.2 above.

10.6.4 An ESH device having a low degree of water resistance, as indicated in the grade by the first characteristic numeral 0³⁾, should be subjected to the test described in 10.6.2 above, without wetting the repaired joints.

10.6.5 Before reconnection to the electrical power supply, the tests described in 4.1.4 should be carried out.

11 Labelling and identification

11.1 General. Apart from the labelling specified for ESH devices in 9.2 and clause 15 of BS 6351-1:1983, it is desirable that all components of an ESH system can be identified both individually and as a part of a complete system or circuit. The method of marking should comply with 9.3 of BS 6351-1:1983.

11.2 Identification of system components

11.2.1 Each means of disconnection and each service, feeder or branch circuit at the point where it originates should be legibly and durably marked to indicate its purpose.

11.2.2 A recommended basis for a sequential alphanumeric identification system uses a combination of letters and numbers as follows.

a) The first two places indicate the purpose of the component, e.g.:

ED	indicates an ESH device
JB	indicates a junction box
TB	indicates a terminal box

³⁾ As defined in clause 4 of BS 6351-1:1983.

TC	indicates a temperature controller
IC	indicates an indicating controller
TI	indicates a temperature indicator
IW	indicates interwiring
CW	indicates control wiring
SC	indicates supply cable

b) The next two places indicate the location or grouping of components, e.g.:

SC01 indicates the supply cable for circuit 1 from mains isolator to first terminal box

TC06/4 indicates a temperature controller on circuit 6 subsection 4

ED 23/indicates an ESH device forming circuit 23

A legend identifying the code should be available at the mains isolator and should be *recorded in the system documentation*.

11.3 Labelling over thermal insulation

11.3.1 Most ESH systems include thermal insulation and labels should be attached to the cladding to identify the circuit beneath. Location markers should be provided for any component that is concealed by thermal insulation.

NOTE Certain installations conveying fluids in liquid or gaseous condition incorporate pipeline marking systems in accordance with BS 1710. The user may wish to apply such markings to the cladding of the ESH system.

11.3.2 Warning labels should be affixed to the cladding of thermal insulation at regular intervals to indicate the presence of concealed ESH equipment.

These labels should be not less than 90 mm × 65 mm in size and fixed at intervals not exceeding 6 m so that they are clearly visible from a normal standing position.

The name, trademark or other descriptive marking by which the organization responsible for the ESH system may be identified should appear on these labels. The marking and fixing should be of sufficient durability for outdoor exposure.

It is recommended that the words **Caution** and **Damage** be emphasized and the symbol for dangerous voltage (⚡) be used. The word **Danger** should not appear.

11.4 Directive labels. Unless otherwise provided, engraved metal or plastics labels should be securely fixed to all equipment that requires a specific action to be taken, e.g. control panels should be marked "Isolate elsewhere before opening".

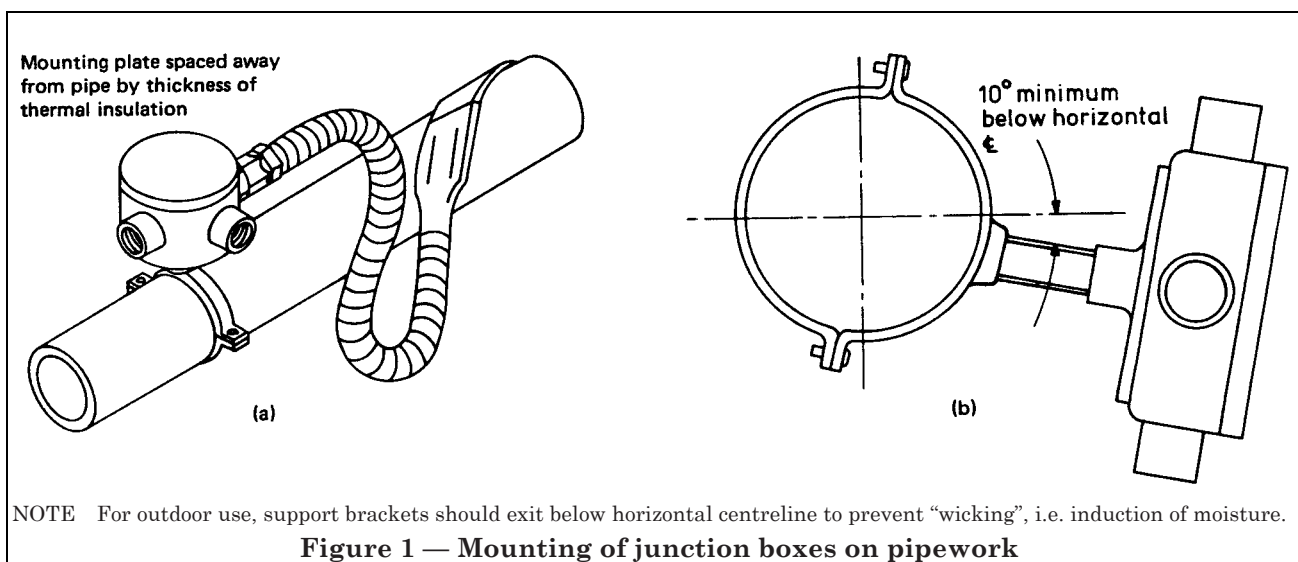

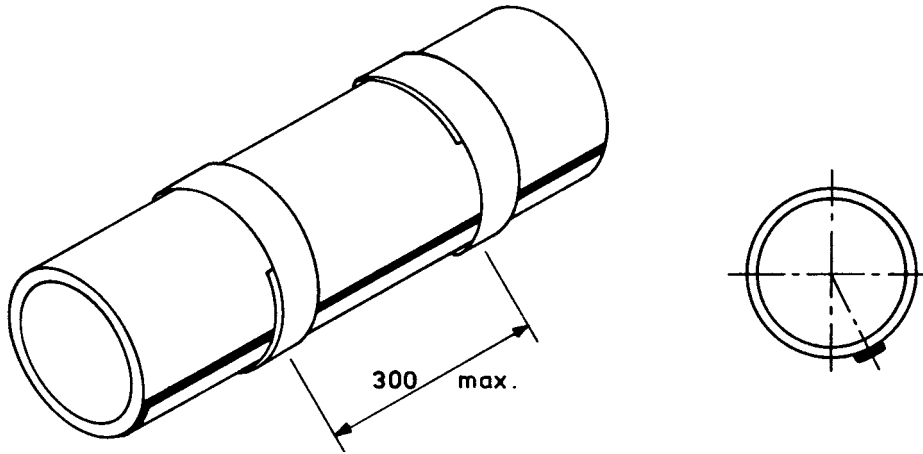

Dimension is in millimetres.

Figure 2 — Single heating tape straight traced on pipework without fittings

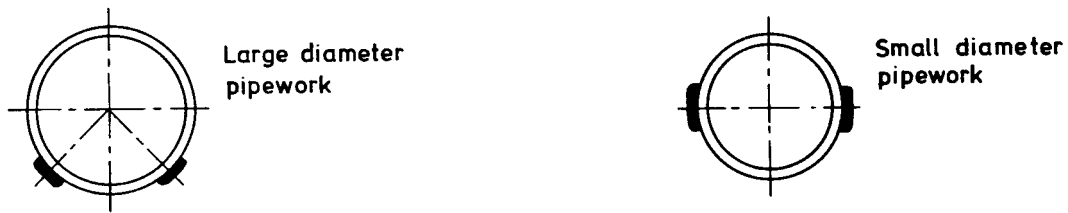

Figure 3 — Double run of heating tape straight traced on pipework without fittings



Figure 4 — Triple run of heating tape straight traced (as for 3-phase)

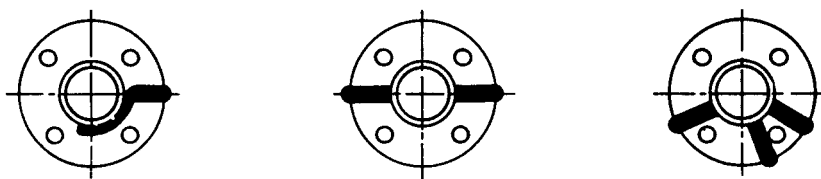
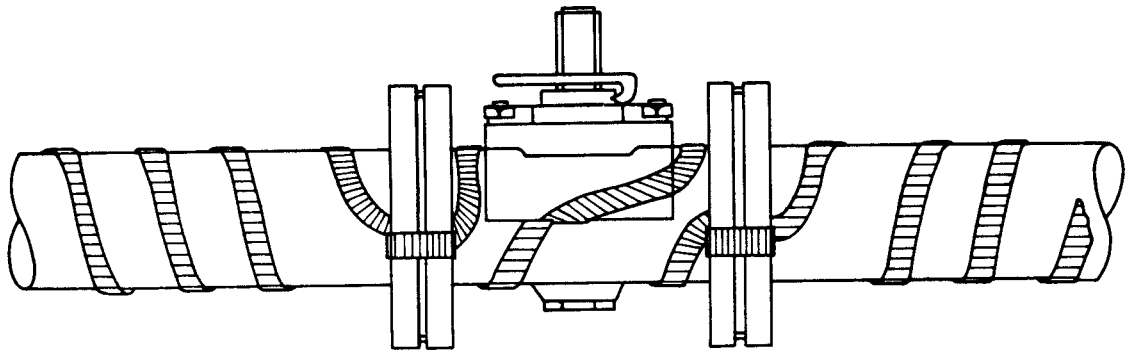
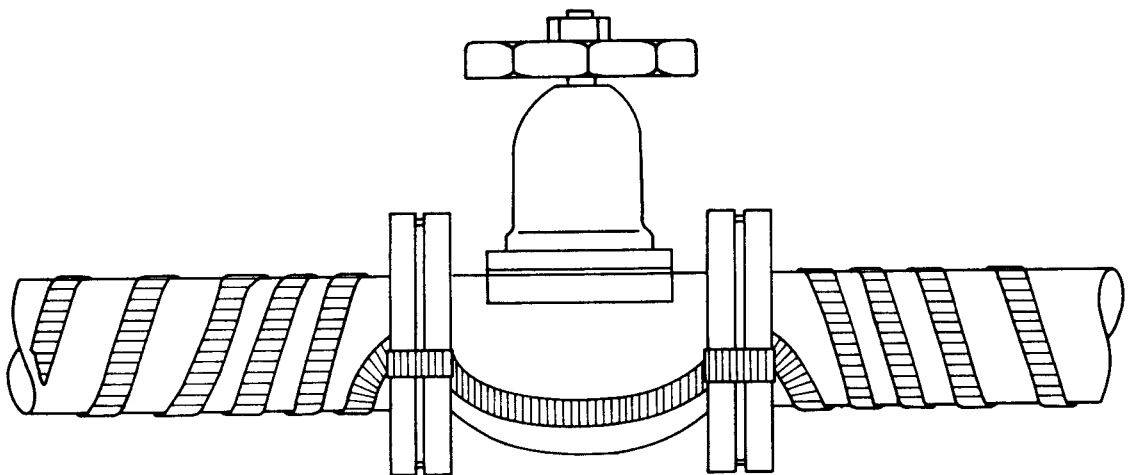

Figure 5 — Routing at flanges to avoid leaks and mechanical damage



(a) Tracing of valve or fitting showing spiral reversal to allow removal



(b) Close spiralling with spiral reversal to allow removal

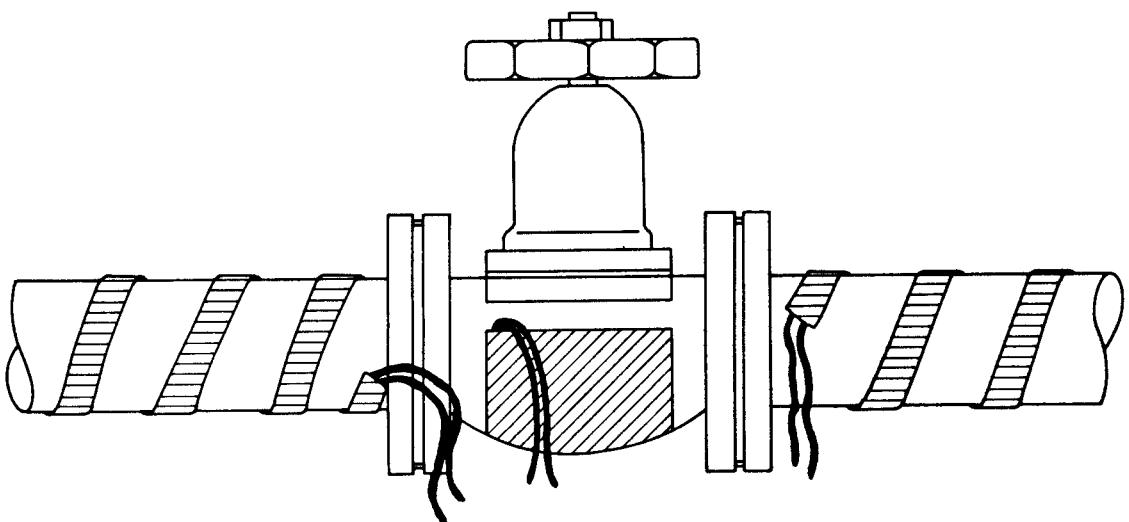

(c) Series connection at valve to allow removal

Figure 6 — Methods for tracing valves, strainers, etc.

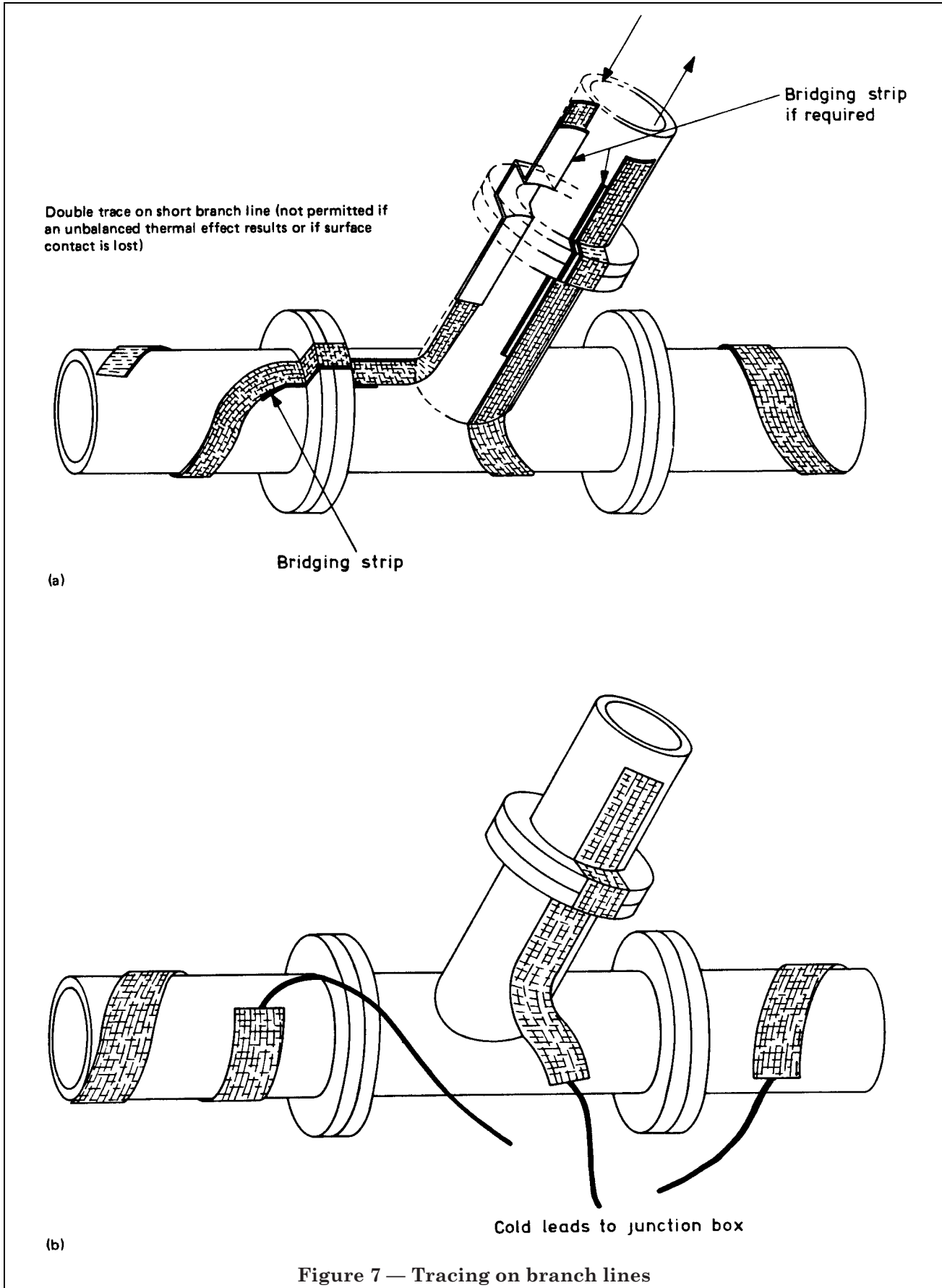

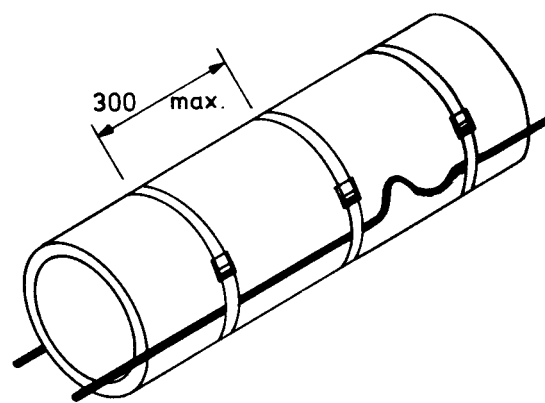
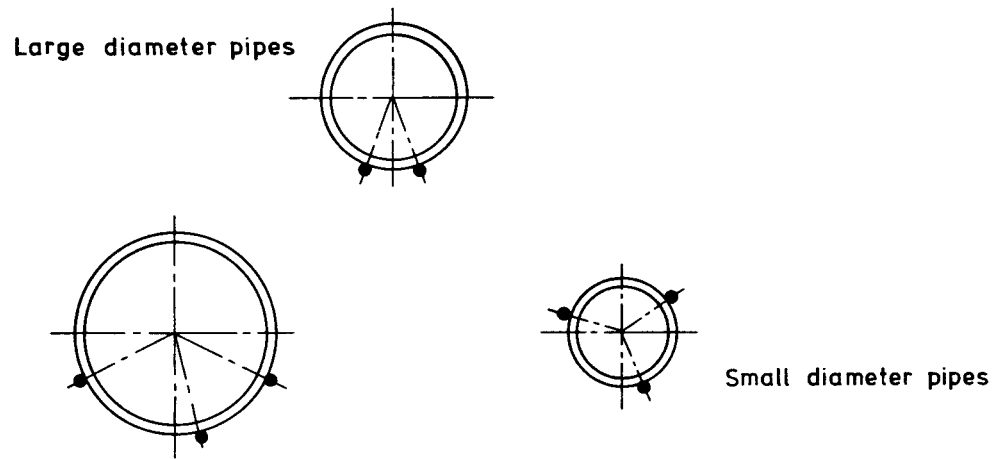

Dimension is in millimetres

Figure 8 — Straight traced heating cables and cable units

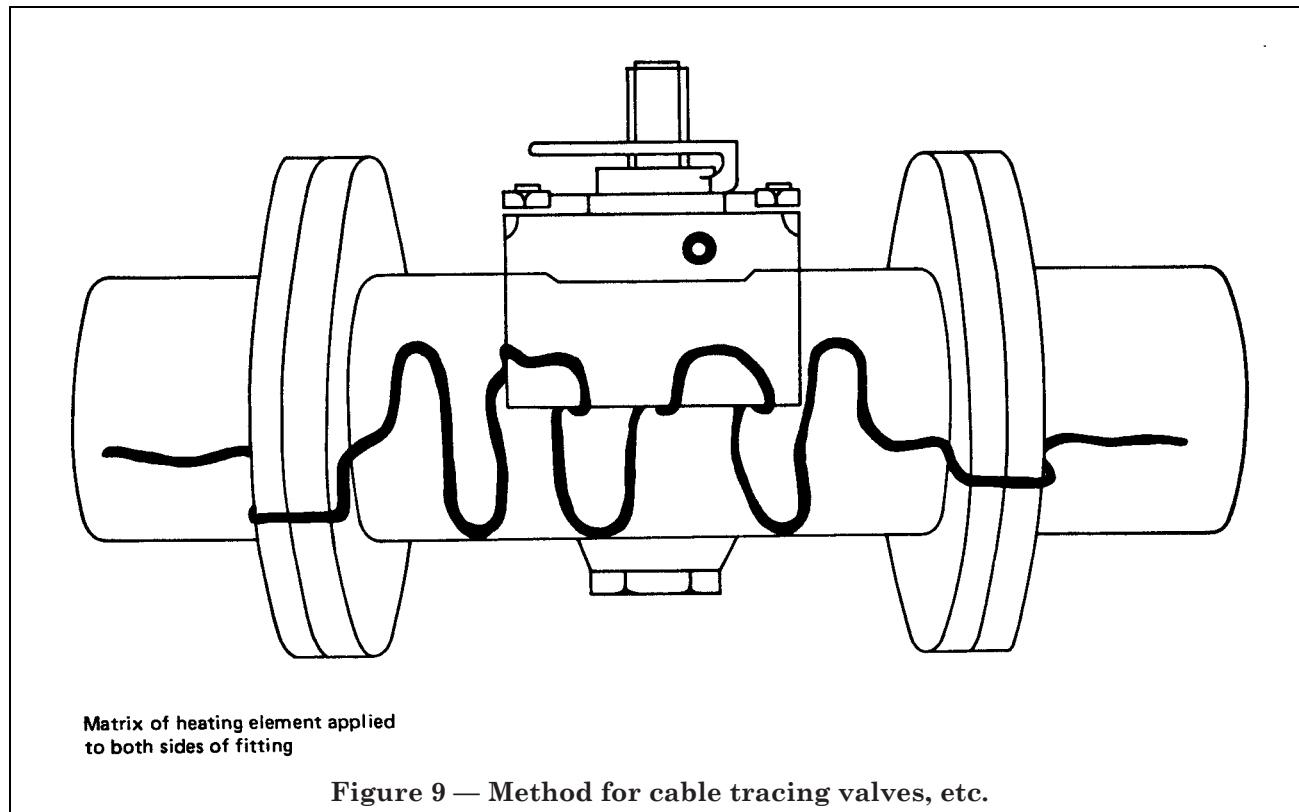

Publications referred to

BS 476, *Fire tests on building materials and structures.*

BS 476-4, *Non-combustibility test for materials.*

BS 476-5, *Method of test for ignitability.*

BS 1710, *Identification of pipelines.*

BS 4683, *Electrical apparatus for explosive atmospheres.*

BS 5345, *Code of practice for the selection, installation and maintenance of electrical apparatus for use in potentially explosive atmospheres (other than mining applications or explosive processing and manufacture).*

BS 5345-1, *Basic requirements for all parts of the code.*

BS 5345-4, *Installation and maintenance requirements for electrical apparatus with type of protection "i". Intrinsically safe apparatus and systems.*

BS 5405, *Code of practice for the maintenance of electrical switchgear for voltages up to and including 145 kV.*

BS 5420, *Specification for degrees of protection of enclosures of switchgear and controlgear for voltages up to and including 1 000 V a.c. and 1 200 V d.c.*

BS 5422, *Specification for the use of thermal insulating materials.*

BS 5490, *Specification for degrees of protection provided by enclosures.*

BS 5501, *Electrical apparatus for potentially explosive atmospheres.*

BS 5970, *Code of practice for thermal insulation of pipework and equipment (in the temperature range of -100°C to $+870^{\circ}\text{C}$).*

BS 6351, *Electric surface heating.*

BS 6351-1, *Specification for electric surface heating devices.*

BS 6351-2, *Guide to the design of electric surface heating systems.*

CP 1013, *Earthing.*

IEE Regulations for Electrical Installations.

BSI — British Standards Institution

BSI is the independent national body responsible for preparing British Standards. It presents the UK view on standards in Europe and at the international level. It is incorporated by Royal Charter.

Revisions

British Standards are updated by amendment or revision. Users of British Standards should make sure that they possess the latest amendments or editions.

It is the constant aim of BSI to improve the quality of our products and services. We would be grateful if anyone finding an inaccuracy or ambiguity while using this British Standard would inform the Secretary of the technical committee responsible, the identity of which can be found on the inside front cover. Tel: 020 8996 9000. Fax: 020 8996 7400.

BSI offers members an individual updating service called PLUS which ensures that subscribers automatically receive the latest editions of standards.

Buying standards

Orders for all BSI, international and foreign standards publications should be addressed to Customer Services. Tel: 020 8996 9001. Fax: 020 8996 7001.

In response to orders for international standards, it is BSI policy to supply the BSI implementation of those that have been published as British Standards, unless otherwise requested.

Information on standards

BSI provides a wide range of information on national, European and international standards through its Library and its Technical Help to Exporters Service. Various BSI electronic information services are also available which give details on all its products and services. Contact the Information Centre. Tel: 020 8996 7111. Fax: 020 8996 7048.

Subscribing members of BSI are kept up to date with standards developments and receive substantial discounts on the purchase price of standards. For details of these and other benefits contact Membership Administration. Tel: 020 8996 7002. Fax: 020 8996 7001.

Copyright

Copyright subsists in all BSI publications. BSI also holds the copyright, in the UK, of the publications of the international standardization bodies. Except as permitted under the Copyright, Designs and Patents Act 1988 no extract may be reproduced, stored in a retrieval system or transmitted in any form or by any means – electronic, photocopying, recording or otherwise – without prior written permission from BSI.

This does not preclude the free use, in the course of implementing the standard, of necessary details such as symbols, and size, type or grade designations. If these details are to be used for any other purpose than implementation then the prior written permission of BSI must be obtained.

If permission is granted, the terms may include royalty payments or a licensing agreement. Details and advice can be obtained from the Copyright Manager. Tel: 020 8996 7070.