

BS 6349-4:2014



BSI Standards Publication

Maritime works – Part 4: Code of practice for design of fendering and mooring systems

bsi.

...making excellence a habit.™

Publishing and copyright information

The BSI copyright notice displayed in this document indicates when the document was last issued.

© The British Standards Institution 2014

Published by BSI Standards Limited 2014

ISBN 978 0 580 66969 9

ICS 47.020.99; 93.140

The following BSI references relate to the work on this document:

Committee reference CB/502

Draft for comment 13/30199621 DC

Publication history

First published March 1985

Second edition, October 1994

Third (present) edition, June 2014

Amendments issued since publication

Date	Text affected
-------------	----------------------

Contents

Foreword *iii*

Section 1: General 1

- 1 Scope 1
- 2 Normative references 1
- 3 Terms, definitions and symbols 2

Section 2: Fendering 4

- 4 General principles 4
 - 4.1 Provision and overall design of fendering systems 4
 - 4.2 Selection and design of fenders 7
 - 4.3 Vessel characteristics 7
 - 4.4 Fender layout for berths and other locations 9
 - 4.5 Berthing procedure 13
 - 4.6 Berthing reactions and load distribution 15
 - 4.7 Moored reactions 18
- 5 Calculation of berthing energies 18
 - 5.1 Characteristic and design berthing energy 18
 - 5.2 Calculation of characteristic berthing energies for alongside berthing 19
 - 5.3 Calculation of berthing energies for ferry and Ro-Ro berths 22
- 6 Selection of fenders and fender types 23
 - 6.1 General 23
 - 6.2 Materials and workmanship 23
 - 6.3 Fenders using elastomeric units 23
 - 6.4 Torsion arm fenders 25
 - 6.5 Pneumatic and foam-filled fenders 25
 - 6.6 Flexible dolphins 26
 - 6.7 Shear capacity of fenders 29
 - 6.8 Fender panels 29
 - 6.9 Mounting and suspension 30

Section 3: Mooring 32

- 7 Principles of good mooring 32
 - 7.1 General 32
 - 7.2 Mooring lines 32
 - 7.3 Mooring layouts 33
- 8 Actions acting on the moored vessel 36
 - 8.1 General 36
 - 8.2 Wind and currents 36
 - 8.3 Hydrodynamic forces 36
 - 8.4 Tidal rise and fall and change in draught or trim due to cargo operations 38
 - 8.5 Ice 38
- 9 Loads on mooring points 39
 - 9.1 General 39
 - 9.2 Calculation methods 39
 - 9.3 Design of mooring point structure 41
- 10 On-shore mooring equipment 41
 - 10.1 Materials 41
 - 10.2 Mounting and fixing 41
 - 10.3 Bollards 42
 - 10.4 Quick release mooring hooks 43
 - 10.5 Capstans 43
 - 10.6 Vacuum mooring systems 44

Bibliography 45

List of figures

- Figure 1 – Geometry of vessel with bulbous bow 8
Figure 2 – Hull and cope geometry at impact 10
Figure 3 – Fender layout on a continuous quay 10
Figure 4 – Fender layout for three island berth 11
Figure 5 – Fender layout for five island berth 12
Figure 6 – Geometry of vessel approach to berth 13
Figure 7 – Ferry and Ro-Ro vessel berthing 14
Figure 8 – Hull and fender geometry at impact 17
Figure 9 – Design berthing velocity as function of navigation conditions and size of vessel 20
Figure 10 – Flexible dolphins 28
Figure 11 – Typical mooring pattern for continuous quay 34
Figure 12 – Optimum angles of mooring lines for island tanker berth 35
Figure 13 – Vessel under influence of stand-off force 37
Figure 14 – Effect of rise and fall of tide and change in draught or trim 39

List of tables

- Table 1 – Typical fendering locations 5
Table 2 – Vessel categories 6
Table 3 – Guidance on hull pressure 16
Table 4 – Coefficients of friction of fender facing materials in dry conditions 29
Table 5 – Mooring point loads for general cargo vessels and bulk carriers 41
Table 6 – Mooring bollards 42

Summary of pages

This document comprises a front cover, an inside front cover, pages i to iv, pages 1 to 46, an inside back cover and a back cover.

Foreword

Publishing information

This part of BS 6349 is published by BSI Standards Limited, under licence from The British Standards Institution, and came into effect on 30 June 2014. It was prepared by Technical Committee CB/502, *Maritime works*. A list of organizations represented on this committee can be obtained on request to its secretary.

Supersession

This part of BS 6349 supersedes BS 6349-4:1994, which is withdrawn.

Relationship with other publications

BS 6349 is published in the following parts ¹⁾:

- Part 1-1: *General – Code of practice for planning and design for operations;*
- Part 1-2: *General – Code of practice for assessment of actions;* ²⁾
- Part 1-3: *General – Code of practice for geotechnical design;*
- Part 1-4: *General – Code of practice for materials;*
- Part 2: *Code of practice for the design of quay walls, jetties and dolphins;*
- Part 3: *Code of practice for the design of shipyards and sea locks;*
- Part 4: *Code of practice for design of fendering and mooring systems;*
- Part 5: *Code of practice for dredging and land reclamation;*
- Part 6: *Design of inshore moorings and floating structures;*
- Part 7: *Guide to the design and construction of breakwaters;*
- Part 8: *Code of practice for the design of Ro-Ro ramps, linkspans and walkways.*

Information about this document

This is a full revision of the standard, and introduces the following principal changes:

- reduction of informative content, with informative guidance separated from recommendations;
- general updating to reflect latest practice;
- change in definitions of berthing mode and navigation conditions.

Use of this document

As a code of practice, this part of BS 6349 takes the form of guidance and recommendations. It should not be quoted as if it were a specification and particular care should be taken to ensure that claims of compliance are not misleading.

Any user claiming compliance with this British Standard is expected to be able to justify any course of action that deviates from its recommendations.

¹⁾ A new part 9 is in preparation.

²⁾ In preparation.

Presentational conventions

The provisions in this standard are presented in roman (i.e. upright) type. Its recommendations are expressed in sentences in which the principal auxiliary verb is “should”.

Commentary, explanation and general informative material is presented in smaller italic type, and does not constitute a normative element.

Contractual and legal considerations

This publication does not purport to include all the necessary provisions of a contract. Users are responsible for its correct application.

Compliance with a British Standard cannot confer immunity from legal obligations.

Section 1: General

1 Scope

This part of BS 6349 gives recommendations and guidance on the design of fendering systems and layouts, mooring devices and mooring system layouts, principally for commercial vessels with a minimum displacement of 1 000 t.

NOTE Some of the provisions in this part of BS 6349 might be applicable to other type of vessels such as naval vessels, provided that the particular vessel characteristics and berthing/mooring procedures are taken into account.

2 Normative references

The following documents, in whole or in part, are normatively referenced in this document and are indispensable for its application. For dated references, only the edition cited applies. For undated references, the latest edition of the referenced document (including any amendments) applies.

Standards publications

ASTM F2192/05, *Standard test method for determining and reporting the berthing energy and reaction of marine fenders*

BS 6349-1:2000, *Maritime structures – Part 1: Code of practice for general criteria*

BS 6349-1-1:2013, *Maritime works – Part 1-1: General – Code of practice for planning and design for operations*

BS 6349-1-4, *Maritime works – Part 1-4: General – Code of practice for materials*

BS 6349-2, *Maritime works – Part 2: Code of practice for the design of quay walls, jetties and dolphins*

BS EN 1993 (all parts), *Eurocode 3 – Design of steel structures*

BS EN 1995 (all parts), *Eurocode 5 – Design of timber structures*

BS EN 60079-10-1, *Explosive atmospheres – Part 10-1: Classification of areas – Explosive gas atmospheres*

BS ISO 17357 (all parts), *Ships and marine technology – Floating pneumatic rubber fenders*

Other publications

[N1] US ARMY CORPS OF ENGINEERS (USACE), NAVAL FACILITIES ENGINEERING COMMAND (NAVFAC), AIR FORCE CIVIL ENGINEER CENTER (HQ AFCEC) and NATIONAL AERONAUTICS AND SPACE ADMINISTRATION (NASA). *Unified facilities guide specifications – Division 35: Waterway and marine construction – Section 35.59.13.16: Marine fenders*. USACE/NAVFAC, 2011.³⁾

[N2] EUROPEAN ORGANISATION FOR TECHNICAL APPROVALS. *Design of bonded anchors*. TR 029. Brussels: EOTA, 2007.

³⁾ Available from <http://www.wbdg.org/ccb/DOD/UFGS/UFGS%2035%2059%2013.16.pdf> [last accessed 25 June 2014].

3 Terms, definitions and symbols

3.1 Terms and definitions

For the purposes of this part of BS 6349, the terms and definitions given in BS 6349-1-1:2013 and the following apply.

3.1.1 berth

area in a port dedicated to the mooring of a vessel and typically equipped with fenders and mooring equipment

NOTE A berth for a large vessel can be used to moor two or more smaller vessels.

3.1.2 berthing line

seaward face of a berth including the uncompressed fendering system

3.1.3 cope

top edge of a quay or jetty adjacent to a berth

3.1.4 design vessel

vessel for which the fendering and mooring systems are designed to permit it to safely berth and be moored under the environmental operating limits

NOTE Where a berth is to accommodate a range of vessels, there will be several design vessels, including as a minimum both the largest and smallest.

3.1.5 fender

item of port equipment designed to keep a vessel from touching the berth structure without damaging itself or the vessel or the berth structure

NOTE The components of a fender can include one or more of the following:

- energy absorbing unit(s), e.g.:
 - elastomeric unit(s);
 - pneumatic unit(s);
 - foam-filled unit(s);
- fender panel;
- facing material;
- fender pile;
- timber sections;
- fender chains:
 - to assist in supporting the static weight of fender panels;
 - to control movement of fender panel;
 - to prevent movement of panels out from berthing line.

3.1.6 fendering system

all the fenders provided for a berth

3.1.7 flat side of vessel

part of the side of a vessel between the bow and stern that is flat, vertical and parallel to the axis of the vessel

NOTE Sometimes also referred to as parallel midships or parallel mid-body.

3.2 Symbols

For the purposes of this part of BS 6349, the following symbols apply.

B	beam of vessel, in metres (m)
C_b	block coefficient of the vessel hull
C_C	berth configuration coefficient
C_E	eccentricity coefficient
C_M	hydrodynamic mass coefficient
C_S	softness coefficient
D_v	draught of vessel, in metres (m)
d	deflection at the level of the application of the load, in metres (m)
E_C	characteristic energy to be absorbed by the fendering system, in kilonewton metres (kN·m)
E_D	design energy to be absorbed by the fendering system, in kilonewton metres (kN·m)
E_F	energy absorbed by the fender, in kilonewton metres (kN·m)
K	radius of gyration of vessel
L_{OA}	overall length of vessel, in metres (m)
L_{BP}	length of vessel hull between perpendiculars, in metres (m)
L_L	overall length of largest design vessel, in metres (m)
L_S	overall length of smallest design vessel, in metres (m)
M_D	displacement of vessel, in tonnes (t)
R	distance of the point of contact from the centre of mass of the vessel, in metres (m)
R_F	fender reaction, in kilonewtons (kN)
V	characteristic velocity of vessel in direction of approach, in metres per second (m/s)
V_B	characteristic velocity of vessel normal to the berthing line at the point of impact, in metres per second (m/s)
α	angle of approach of vessel
γ	angle between the line joining the point of contact to the centre of mass of the vessel and the normal to the axis of the vessel
μ	coefficient of friction

Section 2: Fendering

4 General principles

4.1 Provision and overall design of fendering systems

Berths should be provided with a suitable fendering system to protect berth structures and vessels from damage, taking into account operating conditions as defined in BS 6349-1-1:2013 and stated in the facility operating manual, unless a clear justification can be made that such a system is not required.

NOTE 1 Historically it has been the practice in some ports not to provide fendering to berths other than simple timber rubbing strips, particularly where they are situated in sheltered locations such as impounded dock basins. For commercial vessels, and where berths are situated in more exposed locations such as the outer reaches of rivers and in the open sea, fendering systems are widespread.

The fendering system should be designed taking account of:

- a) the range of vessels berthing;
- b) the methods used to berth the vessel;

NOTE 2 Where a vessel berthing alongside is manoeuvred by tugs and/or the use of thrusters, it is generally stopped a short distance off and parallel to the berth. The vessel is then pushed or warped slowly onto the berth, ideally achieving a gentle contact as near as possible to the berthing line as possible.

NOTE 3 Tugs, launches and other small vessels tend to approach their berths more directly than large vessels.

NOTE 4 Ferries and roll-on/roll-off (Ro-Ro) vessels approach their berths in a different way, which is explained in 4.5.2.

- c) vessels moored during cargo handling operations;
- d) vessels moored during extreme events caused by adverse metocean or other conditions;
- e) the normal operating conditions of the berth;
- f) the risks and consequences as a result of an extreme or accidental event occurring;
- g) the features appropriate to the location of the berth, as shown in Table 1;
- h) the features appropriate to the characteristics of the vessels that are expected to use the berth, as shown in Table 2;
- i) the intended service life of the system, making due allowance for degradation and wear and tear during operations.

NOTE 5 The fendering system might need to be designed to work with the mooring system to reduce vessel movements.

NOTE 6 Fendering systems are required to be suitable for all operational water levels that might occur, and with large variations this becomes particularly important. Winds, waves, current and other factors also vary depending on the berth location.

Table 1 Typical fendering locations

Location	Features to be taken into account in the design of the fendering system
Impounded basins	<p>Approximately constant water level</p> <p>Usually sheltered from high winds</p> <p>Limited fetch for local wave generation</p> <p>Negligible current</p> <p>Range of vessel sizes limited by lock dimensions</p>
Tidal basins	<p>Greater range of water levels than impounded basins</p> <p>Limited wave exposure</p> <p>Limited current</p>
River berths	<p>Variable water level due to changes in river discharge and possibly tide</p> <p>Limited wave exposure</p> <p>Variable current</p> <p>Possible restricted area available for manoeuvring of vessels</p>
Estuarial and coastal berths	<p>Maximum tidal range and currents</p> <p>Greater wave exposure than tidal basins</p> <p>Often dedicated berths with single class or type vessels</p>
Exposed coastal berths	<p>Full exposure to wind, wave and currents</p> <p>Usually specialized trades, e.g. bulk coal, ore, oil (products), LNG, LPG</p> <p>Single type vessels and handling equipment</p>
Locks and lock entrances	<p>Variable water level</p> <p>Limited lateral movement of vessels within the lock</p> <p>Large longitudinal movement of vessels</p>

Table 2 Vessel categories

Category	Features to be taken into account in the design of the fendering system
Bulk carriers	Possible need to be warped along berth for shiploader to change holds Large change in draught between empty and fully laden conditions
Car carriers	Loading ramps, slewed or end loading (vessel mounted or shore based) High windage areas Vessels might have recessed bollards in hull End berthing
Container vessels	Extensive flared bows and sterns with liability to strike shore-side installations Particularly the larger vessels can have a relatively short length of flat side Potential high windage areas
General cargo vessels	Large change of draught between empty and fully laden conditions Possible long occupancy of berths
LNG/LPG carriers	Low allowable hull pressure Single type vessels using dedicated berth Need to avoid fire hazards from sparking or friction Relatively short length of flat side High windage areas
Miscellaneous tugs, supply boats, barges, lighters and fishing boats	Need robust fenders for heavy use Vessels are usually fitted with belting
Passenger liners	Little change of draught between empty and fully laden condition High windage areas Low allowable hull pressure
Roll on-roll off (Ro-Ro) vessels	Loading ramps, slewed or end loading (vessel mounted or shore based) End berthing High windage areas Vessels are usually fitted with belting Vessels usually berth without the aid of tugs
Tankers	Very low amidships freeboard for coastal tankers Large change in draught between empty and fully laden conditions Need to avoid fire hazards from sparking or friction
Train and vehicle ferries	Quick turnaround End berthing High berthing velocities Intensive use of berth High windage areas Vessels are usually fitted with belting Vessels usually berth without the aid of tugs

NOTE Most vessels have bulbous bows. Vessels from all categories could be fitted with belting, particularly smaller vessels.

4.2 Selection and design of fenders

NOTE 1 If the vessel comes alongside at a slight angle to the berth, it usually makes initial contact with one or two fenders. The vessel then rotates before impacting on further fenders.

NOTE 2 Generally, the fender loads during berthing are the controlling influence on the fender selection. However, for offshore ports and for ports with entrances in exposed locations, vessels might berth only during relatively benign conditions, and the greatest fender loading could occur when the vessel remains at the berth during storm events.

The fenders should be designed to protect the berth structure against damage from vessels and to limit the reactive forces on the vessel hull to acceptable values.

The range of available fenders of both proprietary and purpose-made types is considerable. Selection and design should take account of the factors listed in 4.1 together with:

- a) types and hull forms of the vessels that are expected to use the berth;
- b) velocity and angle at which the vessels berth;
- c) range of water levels and range of freeboards of vessels to be accommodated;
- d) offset of fender face to protect quayside equipment;
- e) limits to the distance between berth cope and side of hull after vessels are moored in relation to the outreach of oil loading arms, crane jibs, shiploader booms and similar equipment;
- f) spacing between fenders;
- g) movement of vessels while moored;
- h) number of energy absorbing units that absorb the initial impact energy;
- i) energy to be absorbed by the fenders, having regard to the location and approach conditions of the berth and its method of operation;
- j) reactive forces and deflections on both the berth structure and the vessel hull;
- k) acceleration and deflection limits on berths carrying quay equipment such as pipelines, rail-mounted cranes and shiploaders;
- l) number of fenders that resist the loads from a vessel when moored alongside;
- m) ease with which the berth can be accessed for the maintenance, repair and replacement of fenders and fender components, including facing materials;
- n) metocean actions on the fenders, including from ice and debris.

The design of the fenders should be integrated with that of the berth structure as not all types of fender are compatible with all types of structure.

4.3 Vessel characteristics

4.3.1 General

The characteristics of the design vessels for a particular berth should be established.

NOTE 1 Where specific data is not available, the data relating to appropriate vessels for the proposed berth as given in BS 6349-1-1:2013, Annex D or similar data sources may be used.

The design should allow for the vessel's hull form, e.g. large container vessels might have relatively short flat sides and fast ferries might have high sides with low allowable hull pressure.

NOTE 2 The vessel plans might be available to determine the vessel characteristics.

Where vessels are berthed in a partially laden condition, reference should be made to vessel plans, load-displacement curves or tables to ascertain the hull form and other vessel characteristics such as draught and displacement values.

Where the fendering system is designed primarily for a partially laden or in ballast design vessel, the designer should establish the risk of berthing a more heavily laden vessel, and should take into account the possibility of a fully laden vessel having to return to the berth.

4.3.2 Vessels with bulbous bows

Vessels with bulbous bows pose a greater collision hazard to most berth structures than vessels with a conventionally shaped bow. Where such vessels are to be berthed, the underwater geometry of the bow section should be taken into account in addition to that at the level of contact with the fendering system. The fender spacing, fender outstand after compression and relationship of the berth's substructure to the cope face should also be assessed (see Figure 1), to establish a maximum berthing angle α which is acceptable without impact between the bow and the berth structure.

Figure 1 Geometry of vessel with bulbous bow

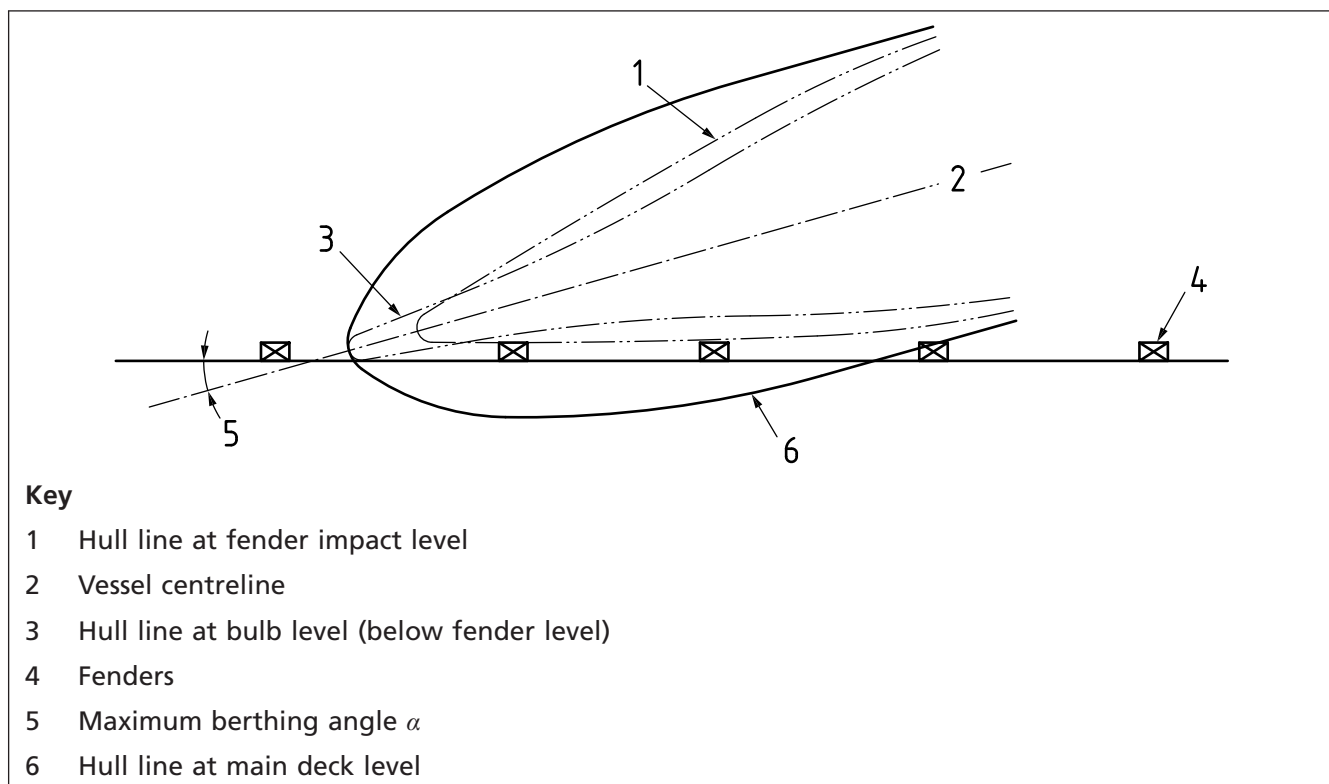

It is generally impracticable to provide a fendering system to safeguard the berth structure against accidental head-on or steeply-angled impacts. The designer should therefore establish a maximum safe value of the berthing angle that can be achieved whilst optimizing both the fendering system and the substructure layout.

4.3.3 Belting

The design of the fendering system should if appropriate take account of belting. Fender panels should be sufficiently long to avoid belting catching the top or bottom of the panel.

NOTE 1 Ferries, and small craft such as tugs and launches, are often fitted with belting that consists of one or more timber, rubber or steel rubbing strips around the vessel. Occasionally this belting is discontinuous and might be in poor condition. On some vessels it might occur at more than one level, particularly towards the stern of the vessel.

NOTE 2 Belting might give highly concentrated loads, catch on edges, giving large vertical loads, and cause localized compression of the fender.

4.4 Fender layout for berths and other locations

4.4.1 General

The design of the fendering system should take into account the berth layout.

NOTE Fendering systems can be classified into three general categories, i.e. those for continuous quays, those for island berths and those for lead-in jetties and locks. Other systems are generally variants of or combinations of these three categories. Fendering systems might be formed of groups of individual fenders or a combination of differing types of fenders.

4.4.2 Continuous quays

NOTE 1 For the purposes of this subclause, a continuous quay is one that provides a straight continuous berthing line for more than one berth.

On continuous quays there is often no precise delineation of individual berths in order to give flexibility of operation and the accommodation of a wide range of vessels. In such cases the fendering system should allow a vessel to berth at any position along the length of the quay. The fendering system usually consists of a series of individual fenders, the positioning of which should be in accordance with the following recommendations.

- a) The fendering system should prevent the vessel striking the berth structure and cargo handling equipment when berthing on the bow or stern quarters (see Figure 2), and allow sufficient fenders to be mobilized for energy absorption. Positioning of equipment during berthing should be discussed with port operations and included in the facility operating manual.

NOTE 2 A typical minimum clearance (see item 5 in Figure 2) is 250 mm at the design deflection.

- b) The fendering system should allow vessels to lie alongside with adequate support from the fenders along the flat side of the vessel hull.
- c) The fender spacing should not exceed $0.15L_s$ (see Figure 3). This is based on conventional hull shapes. Where less conventional hull shapes are to be catered for, such as Ro-Ro vessels with a square stern or any vessels with a large bow and/or stern flare, the spacing should allow for the specific vessel profiles.

NOTE 3 Bow and stern vertical flare varies depending upon the vessel type and design. Vertical flare up to 15° is common on container vessels.

On continuous quays, varying fendering systems could be used where vessels and dredge depths vary, and this should be set out in the facility operating manual.

Figure 2 Hull and cope geometry at impact

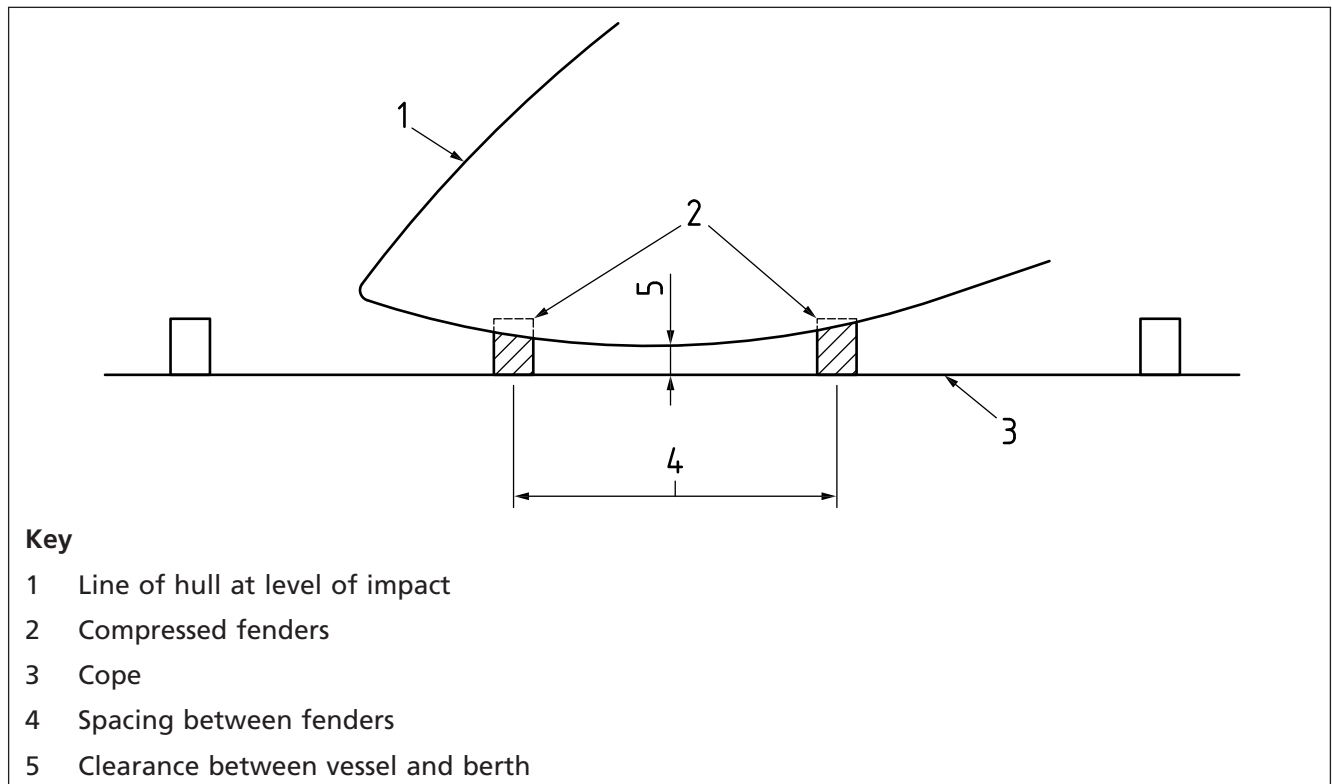
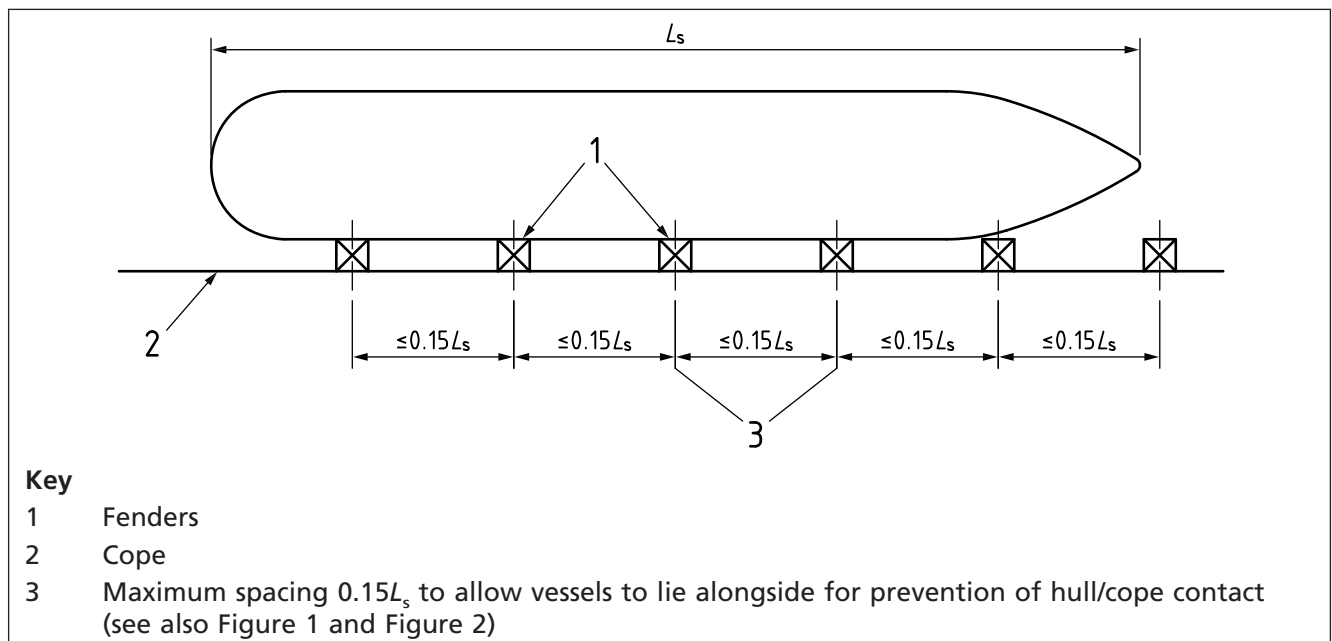

Figure 3 Fender layout on a continuous quay



4.4.3 Island berths

COMMENTARY ON 4.4.3

Where vessels are berthed about a fixed point such as oil loading arms, the primary fenders can be concentrated at two or more points depending on the range of vessels to be accommodated.

The spacing of primary fenders should take account of the actual geometry of the vessels to be berthed. At least two fenders (one at either side of the platform) should make full face contact with the flat side of the vessel hull to provide a sufficient lever arm in the horizontal plane.

NOTE 1 For larger vessels, a minimum of two primary fendering points at each side of the loading arms can provide a back-up in case of individual fender failure.

NOTE 2 A symmetrical fendering arrangement is generally a design optimum.

In the absence of detailed data, the spacing of berthing dolphins should be in the range of $0.25L_{OA}$ to $0.4L_{OA}$ for the complete range of design vessels (see Figure 4 and Figure 5).

A straight berthing line should be adopted to provide optimum support to the flat side of the hull of a moored vessel. Fenders should be selected such as to prevent any overloading of inner fenders at full compression of the outer fenders under design berthing and mooring conditions.

Design of the fendering system should take particular account of:

- prevention of direct impact between vessels and equipment on the loading platform;
- restriction of lateral deflection of the structures to limits acceptable for the equipment;
- prevention of small vessels snagging the primary fenders, taking account of tide levels and waves;
- the risk to port operations due to the damage or failure of one or more fenders.

Figure 4 Fender layout for three island berth

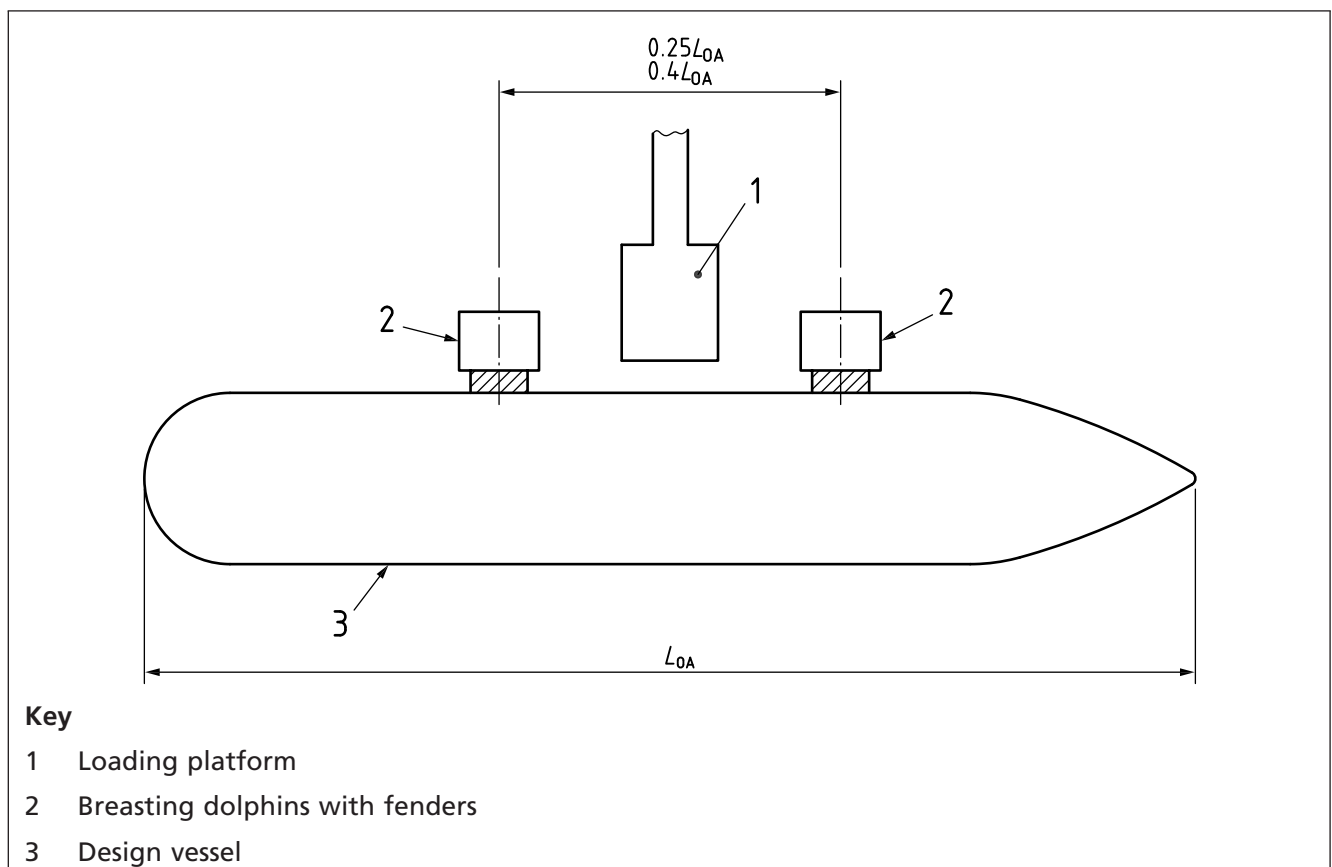
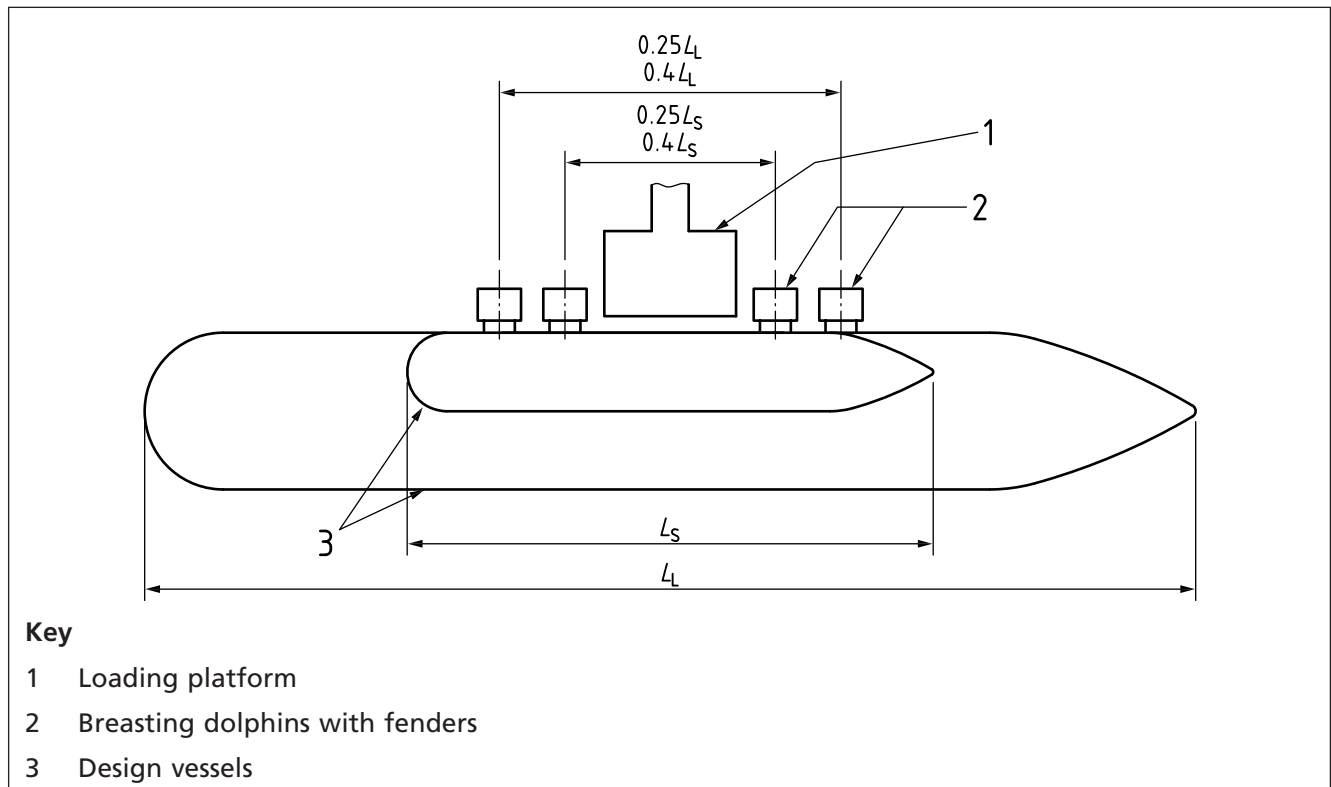

Figure 5 Fender layout for five island berth



4.4.4 Lead-in jetties and lock entrances

Fendering systems for lead-in jetties/approaches, for vessels entering into confined entrances such as locks, dry docks, ship lift systems and passageways, can be grouped into three categories.

- a) Fendering for moored vessels in layby berths awaiting entry into confined entrance. The provision of fendering at layby berths is similar to other berths, except that extra attention should be given to the increased likelihood of vessel wash and surge effects from passing vessels.
- b) Fendering on the approach to a confined entrance. Approaches to confined entrances might comprise either a continuous faced structure or a series of individual. Particular attention should be given to the potential interaction between vessel bow flare and the structures at the lock entrance, especially if lead-in jetties are not provided.

NOTE Approach walls and lead in jetties are not always common practice for entering confined areas. Guidance on lead-in jetties and approaches to locks is given in PIANC Report No. 106 [1].

- c) Fendering required inside the confined area. Within a lock, the principal movement of a vessel as it enters or leaves a lock is almost parallel to the fender line. As lock water level is raised or lowered, the principal movement of the vessel is vertical. Therefore a different design approach should be adopted, based on experience and liaison with vessel operators.

4.5 Berthing procedure

4.5.1 Alongside berthing

The fender design for vessels that are berthed alongside should assume that the vessel's movement is at almost right angles to the berth, i.e. with the vessel almost parallel to the berth, as illustrated in Figure 6.

The maximum design angle of approach should be specified in the facility operating manual (see 5.2.5 for guidance on values).

Figure 6 Geometry of vessel approach to berth

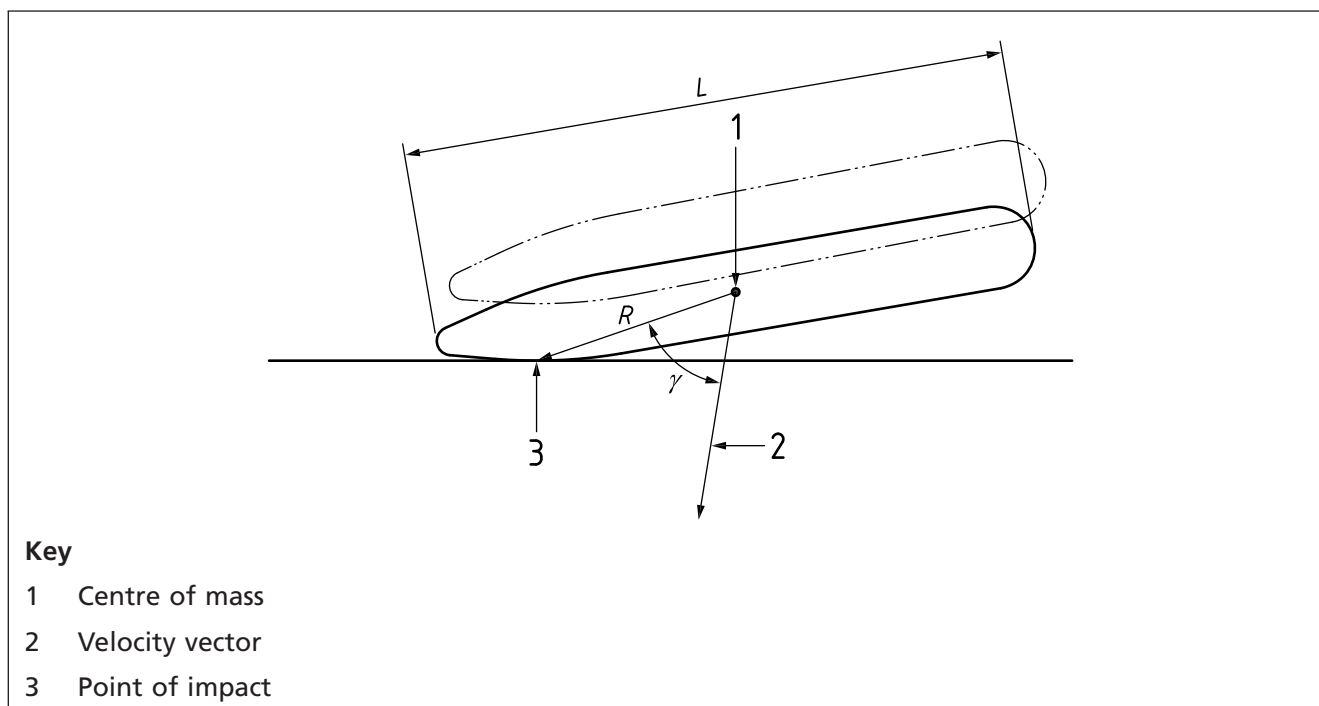

4.5.2 Ferry and Ro-Ro berths

The fender design for ferry and Ro-Ro vessels should be based on the berthing mode, of which the three in common use are:

- a) parallel approach to a row of breasting dolphins or quay and after coming to rest then moving slowly longitudinally to berth end-on against a shore ramp structure;
- b) direct longitudinal approach to berth end-on against or close to a shore ramp structure but using side breasting dolphins or a quay as a guide;
- c) parallel approach to berth alongside a quay and using the vessel's own ramps for vehicle access.

Where there is a possibility that more than one of these modes might be used, the designer should allow for the most onerous. The fendering system design should take into account the first point of contact.

NOTE 1 These three modes of berthing are illustrated in Figure 7a), Figure 7b) and Figure 7c).

NOTE 2 The berth layouts for modes a) and b) are similar and therefore both types of approach could occur at the same berth, possibly by the same vessels in different weather conditions. Vessels with bow ramps might approach the berth using a variation of mode a) or mode b). Mode c) is most likely to be adopted by the larger Ro-Ro vessels where the vessel's bow and stern are not specifically designed for berthing forces. Mode b) is most likely to be adopted by ferries where the vessel's bow and/or stern are designed for end berthing. It is important that the berthing provision is suitable for the vessel's characteristics and the appropriate method of approach.

Figure 7 Ferry and Ro-Ro vessel berthing (1 of 2)

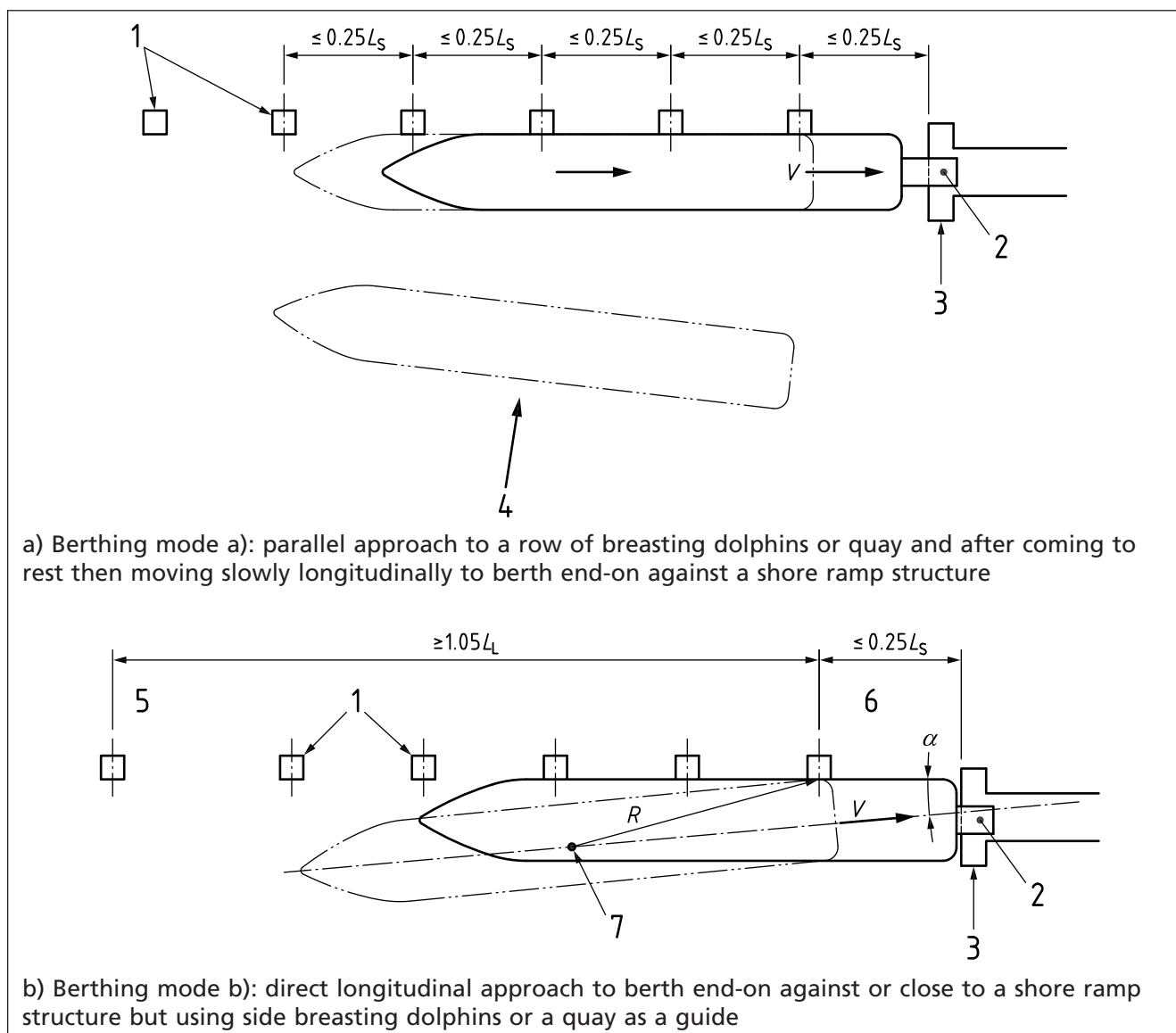
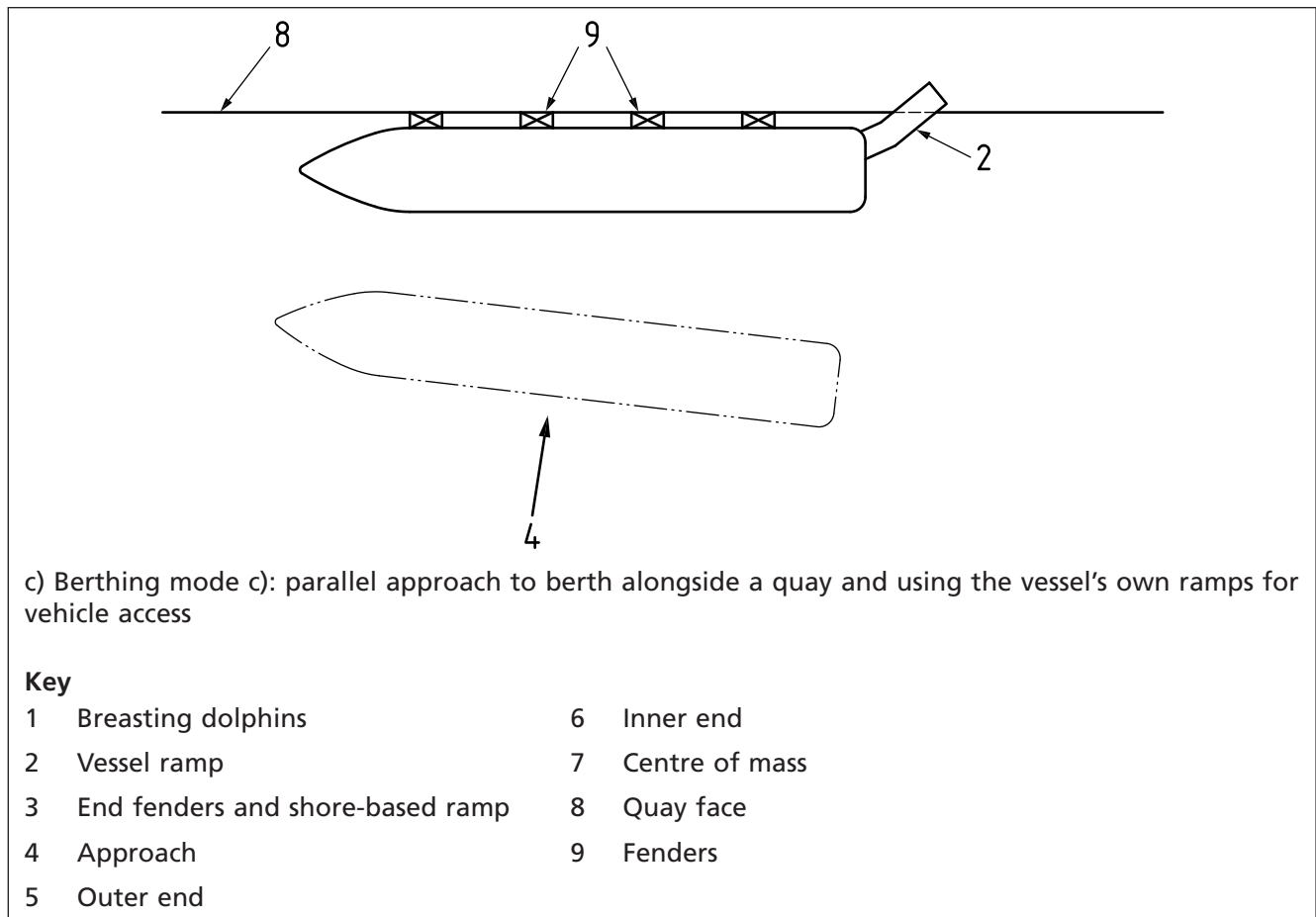

Figure 7 Ferry and Ro-Ro vessel berthing (2 of 2)



4.5.3 Energy absorption distribution

The fendering system should be designed to absorb the design berthing energy.

NOTE For this purpose the fendering system might comprise any one of the following:

- a single elastomeric or pneumatic unit, dolphin pile or other energy absorbing unit;
- a fender made up of a number of energy absorbing units coupled together to form a composite energy absorbing system;
- a number of fenders in sufficiently close proximity that they can be assumed to act together if located at the first point of impact of the vessel.

4.6 Berthing reactions and load distribution

4.6.1 General

Berthing reactions are a function of the berthing energy and the deformation characteristics of the fendering system and berth structure. Berthing reactions should be distributed in such a manner that:

- a) contact pressures on the vessel hull are kept within acceptable limits;
- b) direct contact between the hull and berth structure is prevented;
- c) the capacity of the fender is not exceeded;
- d) the berthing structure can accommodate the fender reaction loads both locally and overall.

4.6.2 Hull pressures

The contact pressure between the hull of the vessel and the fender should be limited so as to avoid damage to the vessel.

NOTE 1 The maximum acceptable contact pressure between the hull and fender is influenced by many factors, including the type and size of vessel, the nature of the fender bearing surface (i.e. rigid or flexible) and the position of the contact area relative to the hull frames.

Hull pressure values should be based on the worst case of full or partial contact with the fender face allowing for tides, loading conditions and vessel freeboard when berthing.

NOTE 2 In the absence of definitive data, Table 3 may be used for preliminary design.

Table 3 Guidance on hull pressure

Type of vessel	Hull pressure kN/m ²
Container vessels	<200
General cargo vessels:	
≤20 000 DWT	200 to 300
>20 000 DWT	<200
Oil tankers:	
≤60 000 DWT	<300
>60 000 DWT	<200
Gas carriers (LNG/LPG)	130 to 200
Bulk carriers	<200
Cruise vessels	<150
Ferries and Ro-Ro vessels (non-belted) ^{A)}	<200

NOTE Smaller vessels might be able to accept higher hull pressures, particularly for designs where a fender bearing surface (panel) is not used.

^{A)} Vessels that are belted, such as ferries, produce highly concentrated loads on the fenders. Typical allowable loads sustainable by ship's belting are 2 500 kN/m to 5 000 kN/m.

4.6.3 Fender energy absorption and reaction due to angular berthing

Unless the point of impact is on the flat side of the hull and the vessel is completely parallel to the berth at impact, the fender receives an angular loading. The hull geometry over the impact area should therefore be reviewed (see Figure 2 and Figure 8) to establish:

- the angle of application of load to individual fenders;
- deflection of individual energy absorbing units within the fender and hence the aggregate amount of energy absorbed by the complete fender;
- clearance between hull and berth structure.

Under angular compression (vertical and/or horizontal), elastomeric fenders provide different reactions and energy absorption characteristics to axial loading, and these should be taken into account in the selection of the fender.

For flexible elastic dolphins, gravity fenders, etc., the effects of angular berthing should be analysed from first principles.

NOTE Where circumstances dictate that angled approaches will be the general practice at a particular berth, it might be necessary to angle the individual fenders relative to the berth, in order to create a closer approximation to parallel berthing conditions and hence more efficient performance of the fender.

Figure 8 Hull and fender geometry at impact

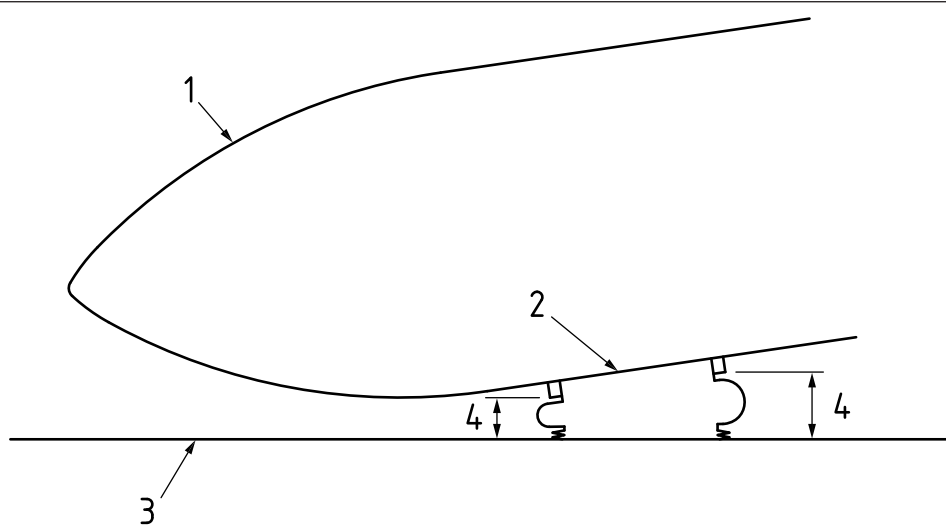

a) Horizontal geometry

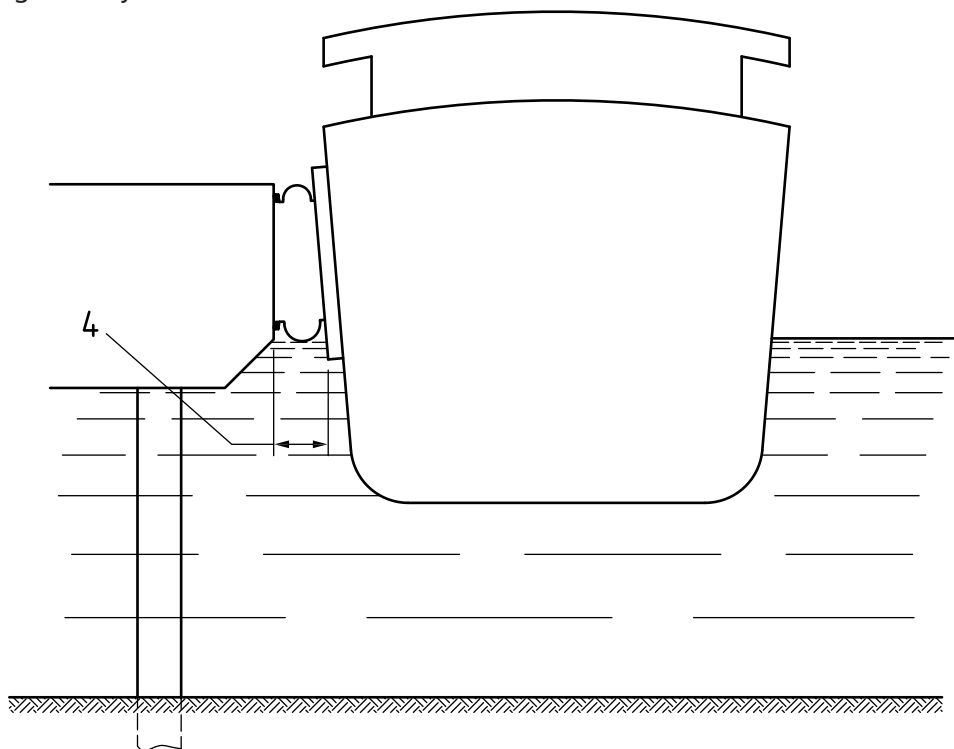

b) Vertical geometry

Key

- 1 Hull line at impact level
- 2 Fender
- 3 Face of cope
- 4 Compressed heights of fender units

NOTE Drawings are diagrammatic only and are not to scale.

4.7 Moored reactions

Whilst a vessel is moored against a berth, the fenders are subject to the following loads or combinations of loads from the moored vessel, and should be designed to accommodate them:

- loads due to wind and currents on the vessel pushing the vessel onto the berth;
- hydrodynamic loads from passing vessels forcing the vessel onto the berth (especially applicable for berths adjacent to shipping lanes where vessels can pass relatively close at speed);
- loads resulting from wave-induced motion response of the vessel;
- mooring loads from mooring lines:
 - some vessels moor using constant tension winches, which can give large loads on fenders;
 - at other times capstans are used onshore to pull the vessel into the berth;
- vertical and horizontal loads on the face of the fenders caused by the motions of the vessel (surge, heave, roll, pitch, yaw and sway). These all give rise to friction on the fender face, although sway can lead to repeated compressions of the fenders as the vessel moves away from and back onto the fender.

NOTE The above loadings can seriously affect the design life of fenders as they cause fatigue.

The geometry of any berth should be taken into account, as this can often lead to uneven loading of fenders.

5 Calculation of berthing energies

5.1 Characteristic and design berthing energy

Two levels of berthing energy, characteristic, E_C , and design, E_D , should be established for the design of the fendering system and the supporting berth structure.

NOTE 1 Characteristic berthing energy was previously referred to as “normal”, design as “abnormal”.

The characteristic berthing energy should be calculated in accordance with 5.2 and 5.3.

The characteristic berthing energy should be multiplied by the berthing energy factor to give the design berthing energy.

The berthing energy factor should be established based on a risk assessment, taking into account the likelihood of the characteristic berthing energy being exceeded and the consequences of the fendering system being overloaded (e.g. time to replace the damaged fender and consequences for downtime of the berth; potential for damage to vessels). The risk assessment process should identify strategies to eliminate, reduce and mitigate structural and operational risks.

NOTE 2 When using a risk-based approach, typical values of the berthing energy factor are 1.5 for low-risk situations and 2.0 for high-risk situations.

NOTE 3 In the absence of data being available for a statistical approach, the following values for the berthing energy factor may be used:

- for a continuous quay handling conventional cargo vessels: 1.5;

- for a ferry berth: 2.0;
- for an LPG or LNG berth: 2.0;
- for an island berth: 2.0.

NOTE 4 A means of significant risk reduction is the installation of equipment on board the ship or on the berth to monitor the vessel's berthing velocities, both normal to the berth and rotational as well as berthing angles, to ensure that they are maintained within permissible operating limits. Such equipment could be either fixed jetty-based systems with display units visible from the ship's bridge, or portable piloting units carried by the pilot.

Because of the non-linear energy/deflection and reaction/deflection characteristics of most fenders, the effects of both characteristic and design berthing energy should be used in designing the fender.

5.2 Calculation of characteristic berthing energies for alongside berthing

5.2.1 General

The energy to be absorbed from a vessel berthing approximately parallel to the berth by the fendering system should be calculated from the following equation:

$$E_C = 0.5 C_M M_D (V_B)^2 C_E C_S C_C$$

5.2.2 Berthing velocities

COMMENTARY ON 5.2.2

The velocity at which a vessel approaches a berth is the most significant of all factors in the calculation of the energy to be absorbed by the fendering system.

For vessel velocities at ferry and Ro-Ro berths, see 5.3.

Where possible, the characteristic berthing velocities should be assessed taking into account:

- the prevailing environmental conditions and environmental operating limits for berthing operations;
- the berthing methods, and in particular the degree of control of berthing provided by use of tugs and thrusters;
- the types of vessels;
- any statistical data available for similar operations and environmental conditions;
- the types of navigation aids and speed of approach monitoring equipment in use where applicable;
- the risks of human error or equipment malfunction in consideration of accidental operating conditions.

NOTE 1 In the absence of any other information, characteristic velocities for alongside berthing with the use of tugs or thrusters may be estimated from Figure 9, on which five curves are given corresponding to the following navigation conditions:

- good berthing, sheltered (i.e. not exposed to waves and/or currents);*
- difficult berthing, sheltered;*
- good berthing, exposed to waves and/or currents;*
- difficult berthing, exposed to waves and/or currents;*
- adverse berthing, exposed to waves and/or currents.*

NOTE 2 The designer's choice of berthing conditions depends on the berthing method proposed for the berth. The following are examples of various berthing conditions.

- A good berthing condition might be when a vessel:
 - can be brought to a stop parallel to the berth; and
 - can manoeuvre or be manoeuvred, without hindrance from other vessels, onto the berth with assistance from tugs and/or thrusters.
- A difficult berthing condition might be when a vessel:
 - is berthing with assistance from tugs and/or thrusters and the vessel is not brought to a stop parallel to the berth; or
 - cannot manoeuvre to a position alongside the berth without hindrance from other vessels; or
 - might be required to change its direction in relation to the berth; or
 - has a significant angular velocity.
- An adverse berthing condition might be when a vessel:
 - is berthing with the assistance from tugs and/or thrusters and the vessel is not brought to a stop parallel to the berth; and
 - cannot manoeuvre to a position alongside the berth without hindrance from other vessels; and
 - might be required to change its direction in relation to the berth; and
 - has a significant angular velocity.

NOTE 3 Where vessels berth without assistance from tugs or thrusters, the berthing velocities might be considerably higher than those given in Figure 9.

A design velocity of at least 0.08 m/s should be used in design irrespective of the actual berthing conditions.

Figure 9 Design berthing velocity as function of navigation conditions and size of vessel

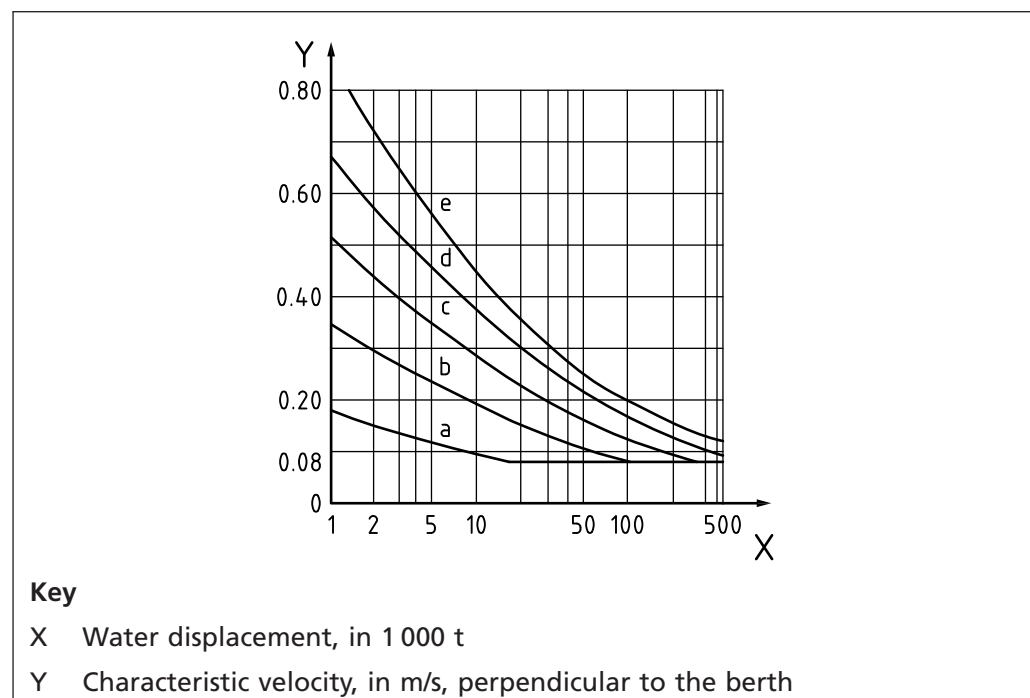

5.2.3 Displacement

The displacement of the design vessel(s) should be given in the facility operating manual.

When using a statistical approach, the designer should adopt the 95% confidence limit for the displacement for the chosen characteristic.

NOTE The displacement might be for a specific vessel(s) or for typical vessels of specified characteristics, e.g. cargo type and length that might use the berth. BS 6349-1-1:2013, Annex D gives characteristics for different vessels for 2011.

5.2.4 Hydrodynamic mass coefficient

COMMENTARY ON 5.2.4

The hydrodynamic mass coefficient, C_M , allows the movement of water around the vessel to be taken into account when calculating the total energy of the vessel by increasing the mass of the system.

For an underkeel clearance greater than $0.1D_v$, the hydrodynamic mass coefficient, C_M , should be calculated from the following equation:

$$C_M = 1 + \frac{2D_v}{B}$$

NOTE Use of this formula generally leads to values of C_M in the range 1.3 to 1.9.

5.2.5 Eccentricity coefficient

COMMENTARY ON 5.2.5

The eccentricity coefficient, C_E , allows for the reduction in energy transmitted to the fendering system when the point of impact is not opposite the centre of mass of the vessel and some energy is absorbed by the rotation of the vessel.

The designer should assess the point of impact of the vessel with the fendering system, taking into account the vessel hull form and arrangement of the fendering system.

C_E should be calculated by means of the following equation:

$$C_E = \frac{K^2 + R^2 \cos^2 \gamma}{K^2 + R^2}$$

where K is calculated from the formula:

$$K = (0.19C_b + 0.11)L_{BP}$$

NOTE 1 Typical values of C_b are given in BS 6349-1-1:2013, Table D.2.

NOTE 2 An illustration of γ is given in Figure 6.

NOTE 3 In assessing the configuration of a tanker or gas carrier relative to the berthing dolphins, the positioning of the vessel may be assumed to be aligned such that the position of the centre manifold is within an eccentricity of $0.1L_{OA}$, but not greater than 15 m, from the centre of the platform (un)loading system. A layout study might be required to assess the effect of variations in the manifold positions on a vessel and the range of product arms on the jetty.

NOTE 4 A value of 6° may be used as a maximum approach angle for vessels larger than 50 000 DWT. For smaller vessels and vessels berthing without tug boat assistance, the berthing angle might be larger, for instance:

- feeders/coasters: 10° to 15° ;
- barges: 15° .

NOTE 5 The berthing angle might be limited by the berth geometry for instance in narrow basins.

5.2.6 Softness coefficient

COMMENTARY ON 5.2.6

The softness coefficient or vessel flexibility factor, C_s , allows for the portion of the impact energy that is absorbed by the vessel hull.

Generally C_s should be taken as 1.0.

NOTE For vessels that are fitted with continuous rubber fenders, or where hard fenders fixed to the structure are used with larger vessels, C_s might be taken to be 0.9.

5.2.7 Berth configuration coefficient

COMMENTARY ON 5.2.7

The berth configuration coefficient, C_C , allows for the portion of the vessel's energy which is absorbed by the cushioning effect of water trapped between the vessel hull and quay wall. The value of C_C is influenced by the type of quay construction, its distance from the side of the vessel, the berthing angle and velocity, the shape of the vessel hull, and its under-keel clearance.

The following values of C_C should be used:

- $C_C = 0.9$ for solid quay walls under parallel approach (berthing angles $<5^\circ$) and underkeel clearance less than 15% of the vessel draught;
- $C_C = 1.0$ for all other cases.

5.3 Calculation of berthing energies for ferry and Ro-Ro berths

5.3.1 Characteristic berthing velocities

Due to the high power of most ferries and rapid turn-round times, operating speeds are generally higher than for other vessels. The designer should determine, where possible, the characteristic berthing velocities that should be adopted for the design from statistical data at the berth location or at a location that has the same berthing conditions and range of vessels.

NOTE 1 The characteristic berthing velocities for ferry and Ro-Ro berths depend on the berthing mode. This is discussed in 4.5.2, where modes a), b) and c) are described.

NOTE 2 In the absence of factual data for side fenders in the case of vessels in mode a) and c), the characteristic vessel velocity may be taken as in 5.2.2. In the case of vessels in mode b), the characteristic vessel velocity would normally be in the range 0.5 m/s to 1.0 m/s for the side dolphins.

NOTE 3 In the absence of factual data for end fenders, the characteristic vessel velocity would normally be 0.15 m/s for mode a) and in the range 0.3 m/s to 0.5 m/s for mode b).

5.3.2 Side fenders

The characteristic energy, E_C , to be absorbed by the side fendering system for a mode a) and mode c) berthing should be calculated from the equation given in 5.2.1.

The characteristic energy, E_C , to be absorbed by the side fendering system for a mode b) berthing should be calculated from the equation:

$$E_C = 0.5 M_D C_M C_S C_C C_E (V \sin \alpha)^2$$

where C_E is calculated in accordance with mode c) and C_M is taken as 1.1.

NOTE 1 The angle of approach, α , is shown in Figure 7.

NOTE 2 A minimum value of 10° is typical for α , except in cases where the berth geometry restricts the vessel to a less angled approach.

5.3.3 End fenders

The end fendering system should be designed to absorb the characteristic energy, E_C , of the vessel. This energy should be calculated from the following equation:

$$E_C = 0.5M_D(V\cos\alpha)^2$$

NOTE 1 In the case of vessels in mode a) berthing and in the absence of factual data, α can be taken as 0° .

NOTE 2 In the case of vessels in mode b) berthing and in the absence of factual data, a maximum value of 15° is typical for α , except in cases where the berth geometry restricts the vessel to a less angled approach.

6 Selection of fenders and fender types

6.1 General

An appropriate fender type should be selected based on the calculated design energy, limitations on reactions, vessel type and berth use (see Clause 4 and Clause 5).

The reaction from fenders should be assessed at the characteristic berthing energy and the design berthing energy.

NOTE The reaction from fenders that rely on buckling to absorb the energy might be similar for the characteristic and design berthing energy.

The design working life category of a fendering system should be category 2 as defined in BS 6349-1-1:2013, Table 1, and is typically 15 years. Some components, e.g. chains, should be assumed to be temporary structures, i.e. category 1.

6.2 Materials and workmanship

NOTE Fender systems incorporate some or all of the conventional construction materials of steel, concrete and timber together with natural or synthetic rubber and other materials.

All materials and the associated workmanship should be in accordance with BS 6349-1-4, other British Standards relevant to the material being used, or other equivalent internationally recognized standards where there is no relevant British Standard.

6.3 Fenders using elastomeric units

COMMENTARY ON 6.3

This category of fenders represents the largest group in general use.

Elastomeric units are generally mounted directly on rigid structures such as caissons, solid quays or piled structures having minimal energy absorption capacity of their own, but might be used in combination with flexible dolphins.

The performance of elastomeric units varies with temperature, berthing velocity and angle of impact.

The characteristics of the different types of fenders can be obtained from the manufacturers.

Elastomeric units are made of natural or synthetic rubber or a blend of the two and formed into various shapes. They absorb the impact energy by means of their deflection. Use of recycled rubber should be restricted in the manufacturing of elastomeric units unless its use is proven to provide adequate durability and energy absorption capacity of the elastomeric units over the design life of the fender.

Elastomeric units should be manufactured and tested in accordance with ASTM F2192/05 and the requirements of the design.

The fender should be selected to provide sufficient energy absorption over the design berthing energy, allowing for the following reduction factors to the rated performance data:

- temperature range;
- angle of impact;
- berthing velocity;
- manufacturing tolerance.

The fender manufacturer might state a tolerance on the figures quoted for reactions and energies. The design energy of the fender should be reduced by the manufacturing tolerance and the reaction should be increased by the manufacturing tolerance. If no tolerance is quoted, a tolerance of $\pm 10\%$ should be used.

The design maximum and minimum temperatures should be assessed taking into account the implications of a berthing taking place outside the design temperature range.

NOTE The reactions corresponding to given energy absorption may be obtained directly from the performance curves for a given fender, adjusted for temperature, angular effects, berthing velocity and manufacturing tolerance.

Reactions that are significantly higher than the manufacturers' stated values and tolerances can occur in the following situations.

- a) Elastomeric fenders show a higher reaction the first time they are compressed. This might be 100% above the manufacturer's quoted values. The designer should determine whether all energy absorbing units should be "broken in" before installation by subjecting them to at least one compression cycle.
- b) Voids in some energy absorbing units when submerged can fill with water. The water might not escape quickly enough when the unit is subsequently compressed and this results in significantly increased reactions. This can occur with cone and cell type units. To cater for this, adequate venting should be provided to allow the water to escape within the time that the fender is compressed. The possibility of marine growth obstructing any vent holes should be taken into account when establishing the size of the vents.

When determining the reaction of elastomeric fenders, a temperature factor should be applied to allow for the change in stiffness of the polymers that can lead to higher reaction forces at low operating temperatures.

6.4 Torsion arm fenders

Where torsion arm fenders are to be used, they should be selected and designed with care, and the design should allow for the following specific factors.

- a) Torsion arm fenders generally comprise a vertical fender panel with one or two elastomeric units mounted in series. A substantial structure maintains the panel in a nominally vertical plane during vessel impact. The structure is hinged in such a way as to allow the large deflections required and to allow the fender panel to rotate about a vertical axis to conform to the vessel hull shape. The generally perceived advantage is that by keeping the panel face reasonably vertical, it can cope better with a high tidal range and vessels with belting.
- b) The elastomeric units are normally attached to the quay structure around mid-height of the panel. The restraint mechanism is attached to the quay structure vertically above and below the elastomeric unit attachment point. For berths with a high tidal range this might mean the lower attachment point and lower part of the mechanism are submerged for the majority of each tidal cycle. This might also be the case for the elastomeric units.
- c) The hinged mechanism which retains the fender panel in a nominally vertical position prevents movement of the fender panel vertically and longitudinally. The compression of the elastomeric units is generally non-axial due to the geometry of the mechanism.
- d) The ability of torsion arm fenders to deflect small amounts without taking up significant load is severely limited by the torsion arm mechanism. Any longitudinal loading when the fender is being slightly compressed by a vessel is taken directly through the torsion arm mechanism. Similarly any vertical load is taken through the mechanism, not the elastomeric unit. This causes the elements within the torsion arm fender to fatigue, and a fatigue analysis of all components should be carried out for the combination of loads from berthing and when vessels are moored alongside.

6.5 Pneumatic and foam-filled fenders

6.5.1 Pneumatic fenders

COMMENTARY ON 6.5.1

Pneumatic units comprise a hollow rubber bag filled with air, berthing energy being absorbed by the work required to compress the air. They are generally in the form of cylinders floating in front of the berth structure and compressed diametrically. Contact with the vessel can be direct or via a berthing frame mounted over one or more pneumatic units.

Pneumatic units are pressurized to a pre-set value in their uncompressed condition and some are fitted with pressure relief valves.

Pneumatic fenders should be capable of absorbing the design berthing energy (see 5.1) at a compression not exceeding that specified as the maximum by the fender manufacturer. The relief valve (if provided) should be set to operate at a compression slightly above this level.

Pneumatic fenders should be manufactured and tested in accordance with and conform to BS ISO 17357 and the requirements of the design.

6.5.2 Foam-filled fenders

COMMENTARY ON 6.5.2

Foam-filled units consist of a resilient closed cell expanded foam block covered by a elastomeric skin or urethane skin, berthing energy being absorbed by the work required to compress the foam cells. They are generally in the form of cylinders floating in front of the berth structure and compressed diametrically.

Foam-filled fenders should be capable of absorbing the design berthing energy (see 5.1) at a compression not exceeding that specified as the maximum by the fender manufacturer.

The rated performance should be factored to allow for the number of loading cycles, as the energy capacity will deteriorate over the life of the fender.

When determining the reaction of foam-filled fenders, a temperature factor should be applied to allow for the change in stiffness of the polymers that can lead to higher reaction forces at low operating temperatures.

Foam-filled fenders should be tested where applicable in accordance with the following standards:

- parallel and angular compression test, compression recovery test: BS ISO 17357 or ASTM F2192;
- cyclic compression test, sustained-load test, fender pull-through test, skin thickness core test: USACE/NAVFAC UFGS-35.59.13.16 [N1].

6.6 Flexible dolphins

6.6.1 General

COMMENTARY ON 6.6.1

Flexible dolphins are formed of vertical or near vertical piles cantilevered from the river or sea-bed that absorb the berthing energy by deflection of the pile heads horizontally under the berthing impact. Dolphins might be formed of piles acting either singly or in groups that are suitable for impacts from any direction, or of panels of box/sheet piling that are most suitable for primary impacts perpendicular to the panel only.

Suitability of flexible dolphins is dependent on soil conditions capable of resisting the horizontal loads exerted by the embedded length of the pile during impact of the vessel and of returning the pile to its original position when the berthing or other applied forces have ceased to act.

The design energy absorption, E_F , for an unpropped cantilever fender should be calculated from:

$$E_F = 0.5R_F d$$

6.6.2 Loadings

Flexible dolphins should be designed to resist the following forces, and the effects of torsion from:

- a) berthing impact;
- b) rope pulls where the dolphin is also used for general mooring purposes or for warping vessels into passages, locks and dry-docks;
- c) wind, wave and current effects;
- d) the moored vessel being blown against the berth;
- e) friction from the vessel moving in relation to the fender.

Dynamic and fatigue effects should be assessed in the design where cantilever dolphins are located in areas with fast flowing currents and where vessels are moored permanently against the fender.

6.6.3 Pile analysis

COMMENTARY ON 6.6.3

In the case of flexible steel pile dolphins, a significant portion if not all of the energy of impact has to be absorbed by lateral deflection of the piles. The contribution of the pile to the energy absorption depends on the characteristics of the fender installed on the dolphin pile, if any.

Flexible steel dolphins should be designed in accordance with BS 6349-2, including the verification of fatigue.

6.6.4 Design deflections

Although pile deflections are primarily limited by consideration of stress and energy factors, deflections should also be limited such that:

- a) deflected dolphins do not foul adjacent structures;
- b) access bridges or catwalks supported by the dolphins are not dislodged;
- c) there is no direct contact between the vessel hull and the walls of the piles.

The designer should also take into account the rate of acceleration and overall movement of the dolphin, which might support access walkways and platforms, and which might be being used by mooring gangs at the time of impact.

6.6.5 Decks and berthing frames

Decks, if necessary, should be capable of transmitting to the piles the primary berthing force, the secondary reaction due to friction and all associated moments including torsional moments induced by the eccentricity of the impact. The deck system should support the berthing face at a sufficient distance from the piles to prevent contact between them and the hull as they deflect.

Contact between hull and dolphin might be via vertical rubbing strips bolted to the face of the pile, but berthing frames should be provided where necessary to keep contact pressures within allowable limits.

NOTE The berthing frame might be in one plane or of a "wrap-around" type dependent on the direction or directions from which berthing impacts are expected to be received.

Flexible dolphins formed of groups of piles should have a deck or series of decks at various levels connected to a common berthing frame. These decks should be capable of fully mobilizing all piles in the group to resist the berthing energy.

In all cases of flexible pile dolphins, local effects at the points of application of the impact forces should be investigated and stiffening provided as necessary. This might be in the form of internal steel ring stiffeners or concrete plugs.

6.6.6 Flexible dolphins with fenders

NOTE 1 Where particularly large berthing energies are required to be absorbed, the capacity of flexible dolphins can be enhanced by the addition of a pneumatic, foam-filled or elastomeric fender to the front face of the dolphin. Figure 10 shows an indicative arrangement, identifying the main elements.

If floating fenders are used, the berthing frame of a multi-pile dolphin or the panel width of a box/sheet pile dolphin should be sufficient to support the fenders in their compressed condition. The mounting system should be in accordance with 6.9.

Figure 10 Flexible dolphins

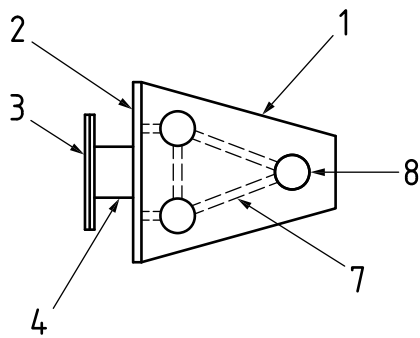

Plan of elastomeric fender
a) Flexible dolphin with elastomeric fender

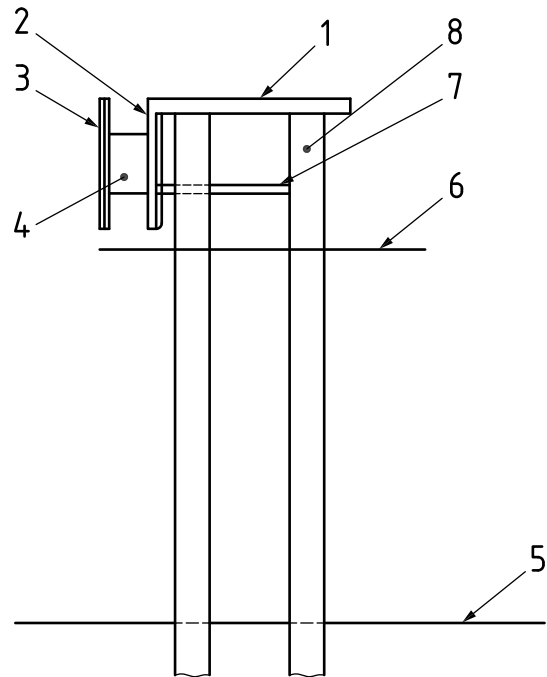

Side elevation of elastomeric fender

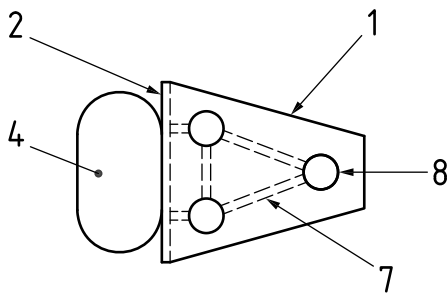

Plan of pneumatic fender
b) Flexible dolphin with pneumatic fender

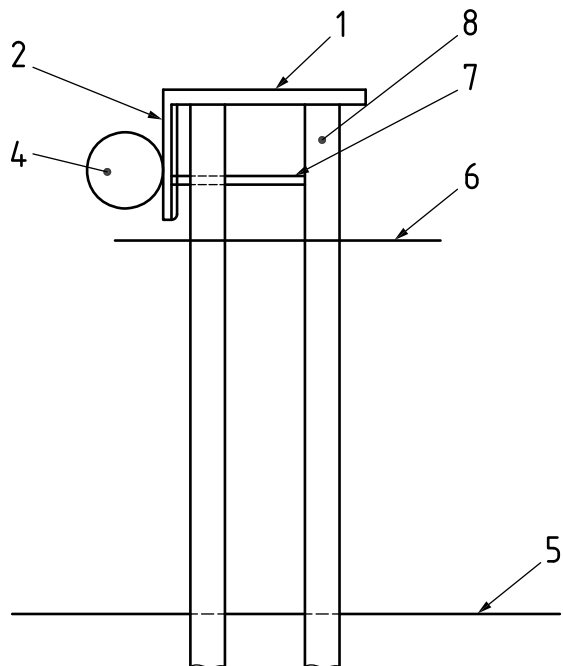

Side elevation of pneumatic fender

Key

- | | |
|------------------|------------------|
| 1 Deck | 5 Bed level |
| 2 Berthing frame | 6 Water level |
| 3 Fender panel | 7 Secondary deck |
| 4 Fender | 8 Pile |

The design of the combined system should allow for:

- a) the shape of the load/deflection characteristics for the compressible fender. With a buckling type fender, the flexible dolphin could be subjected to the maximum design deflection on most berthings. The flexible dolphin should be verified for fatigue based on the number of load cycles and anticipated berthing energy distribution;
- b) the range of performance of the compressible fender, taking into account manufacturing tolerances and temperature effects;
- c) the overall geometry of the dolphin and fender when under compression and the surface that remains in contact with the vessel hull;
- d) the method of connecting the fender to the dolphin. Given the potential vulnerability of the dolphin, the fender or its connecting bolts should be designed to fail before any welded connection to the dolphin pile. In this way replacement will be less difficult.

6.7 Shear capacity of fenders

Vessels moving longitudinally or vertically on a berth induce friction forces at the contact surface between the fender and the hull. These forces induce shear deformations in the fender and these should be kept within the fender's design limits.

Large shear deflections should be limited by chains connecting appropriate parts of the fender to the berth structure.

Shear forces should be calculated using the relevant coefficient of friction, μ , multiplied by the normal force at the fender face.

In design, a minimum friction factor of 0.3 should be taken, even for low friction materials, to allow for wear in the design service life.

NOTE Typical values of μ are given in Table 4.

Table 4 Coefficients of friction of fender facing materials in dry conditions

Material	Coefficient of friction, μ
UHMW-PE	0.2
HDPE	0.3
Nylon	0.2
Rubber	0.6 to 0.7
Timber	0.4
Steel	0.5

NOTE 1 The coefficient of friction of UHMW-PE varies with grade of material and pressure exerted on the facing material.

NOTE 2 The above coefficients of friction apply only where smooth contact surfaces are present.

6.8 Fender panels

Fenders and/or panels for berths should be smooth-edged to prevent chafing of the vessels' lines by sharp edges on the fenders. The fender panels should incorporate tapers or chamfers on the top, bottom and sides of the panels of sufficient dimensions to prevent hull protrusions, discontinuities, beltings, mooring lines and similar features from snagging or hanging up on a fender panel.

Where necessary, fender panels should be provided with chains to prevent excessive shear movements. When the berth layout is such that mooring lines, when released, are at risk of snagging behind fender panels or fixings, additional chains at the outer corners of the fenders should be provided to prevent this from happening.

Fender panels should be designed to allow the panels or fenders to be replaced as whole units.

Where a fender panel is used to reduce the contact pressure, or to couple a series of units into a single fender, the fender panel should be one of the following:

- a) a purpose-designed steel frame designed in accordance with BS 6349-2 and BS EN 1993;
- b) a purpose-designed timber frame with stresses in accordance with BS EN 1995 treating berthing impacts as short-term loadings.

Steel frames should be faced with suitable materials to minimize abrasive contact with and from the hull of the vessel.

NOTE Facing materials might be of timber or polymers or other suitable materials referred to in Table 4.

Fixings should be such that worn or damaged facing panels can be easily and rapidly replaced. The heads of fixing bolts, set screws, etc. should be recessed into the wearing face to avoid direct contact with the hull plating, with an allowance for wear of the facing panels.

Measures should be taken to avoid loosening and fatigue of bolts due to cyclic loads.

The design should allow for access to contact faces for maintenance or replacements, having regard to the location of the berth and ease of access for people and equipment. The individual elements of the facing panels should allow safe handling.

6.9 Mounting and suspension

6.9.1 General

Mounting and suspension systems for fenders should be of robust and simple design, with the use of hinges, anchor chains, turnbuckles and similar devices kept to a minimum. Where practicable the mounting systems should be above the water level or splash zone. Where mounting below the water level or splash zone is unavoidable, the system should allow for maintenance, repair and replacement activities.

Where fenders are mounted on structures with cathodic protection against corrosion, the mounting system should be designed to prevent stray electrical currents having corrosive or other adverse effects on the fenders.

Metals should be chosen or insulated to avoid electro-chemical corrosion. No mountings (including stainless steel) should be allowed to be in contact with steel reinforcement in concrete.

In circumstances where severe overloading of the fender might lead to failure of the fender to berth connections, suitable back-up measures should be taken to prevent the fender becoming detached from the berth structure.

If the supporting berth structure is of concrete and of new build, it should be fitted with built-in threaded anchor sockets for the fender fixing bolts.

Retrofitted fixings should be designed in accordance with EOTA TR 029 [N2].

Chains should be galvanized and should be designed with a factor of 3 on the minimum breaking load.

Bolts should be of stainless steel or galvanized so that corrosion is minimized to allow easy removal of the fender for maintenance or replacement.

Galvanized bolts and accessories should not be used underwater, as the galvanizing is subjected to galvanic corrosion.

NOTE Where galvanized chains, bolts and accessories are submerged or partially submerged, they can act as an anode if connected to a steel structure.

6.9.2 Floating fenders

Suspension systems for fenders designed to float, such as horizontal timber or pneumatic or foam-filled fenders, should allow easy travel of the movable elements and minimize mechanical wear and the aggravation of corrosion in the supporting structure.

Mooring systems for floating fenders, which generally comprise chains or wire ropes with swivels and shackle connections to anchor points in the fixed structures, should:

- a) retain the fender close to the berth structure at all states of the tide and in all wind, wave and current conditions when the berth is either empty or occupied;
- b) prevent the fender from rolling up over the cope under the berthing action;
- c) be suitably protected to minimize damaging abrasion against the berth and vessel;
- d) minimize damage to the berth structure or the vessel in the event of the fender being dragged off-station by an incorrect vessel approach or by any other cause;
- e) allow sufficient range of movement to avoid wave-induced snatch on fixings at high and low water.

The contact area of a compressible fender increases considerably with compression, and the mounting on the berth should allow the full contact area between fender and berth to be developed under impact over the full tidal range.

NOTE In some cases it might be necessary to extend the bearing face above the cope to prevent floating fenders from riding over, provided that this is compatible with the accommodation of the mooring system and berth operations.

Section 3: Mooring

7 Principles of good mooring

7.1 General

The mooring design should permit all vessels for which the berth is designed to:

- remain safely moored alongside for the conditions as described in the facility operating manual;
- allow cargo handling operations to be conducted safely;
- minimize the time to safely berth, moor and cast-off.

The mooring arrangement should restrain movement to within acceptable limits of the (off)loading equipment by means of an adequate number of mooring lines, which can be readily handled by the operating personnel, compatible with the varying conditions of wind, tide, current, weather, vessel loading and other effects likely to be experienced during the relevant period of vessel stay at the berth.

NOTE BS 6349-1-1:2013 gives guidance on vessel data. BS 6349-1-1:2013, Annex D gives key dimensions of ships for preliminary design, and BS 6349-1-1:2013, Annex E gives guidance on the assessment of acceptable wave conditions for moored vessels.

7.2 Mooring lines

7.2.1 Breast lines

The restraint required to secure the vessel alongside the berth is best obtained using breast lines. These should be aligned as perpendicular as possible to the longitudinal centre line of the vessel, in order to apply the maximum restraint to prevent the vessel being moved broadside from the quay.

NOTE Short breasting lines require continual adjustment to compensate for tide level and draught changes with load.

7.2.2 Spring lines

Spring lines should be aligned as parallel as possible to the longitudinal axis of the vessel to apply the maximum restraint to minimize the vessel motion along the quay.

7.2.3 Head and stern lines and additional mooring lines

COMMENTARY ON 7.2.3

Additional head and stern lines might on occasion be required to assist in the berthing or manoeuvre of a vessel, particularly where a vessel is being moved along a quay without use of main engines to achieve final positioning.

The need for head and stern lines is likely to arise where the vessel is moored to widely spaced dolphins necessitating corresponding widely spaced mooring connections ashore or, for example, where a large vessel has to make use of a quay intended for smaller vessels and therefore has to distribute the mooring lines to avoid overloading the bollards on the quay. Conversely, a small vessel mooring at, for example, a berth primarily designed for larger vessels is likely to find the bollards or hooks on the dolphins so far apart as to result in some of the mooring lines being in effect head and stern lines.

Head, stern and additional mooring lines, where deployed, should be incorporated into the overall mooring pattern to supplement breast and spring lines.

7.3 Mooring layouts

7.3.1 General

To ensure even distribution of the restraining forces on the vessel, the pattern of mooring lines should be approximately symmetrical about the midpoint of the vessel.

NOTE 1 The optimum pattern of mooring lines for normal alongside berthing is likely to consist of a basic array of breast, head and stern lines extending from or near the extremities of the vessel, together with spring lines from approximately the quarter points of the vessel.

NOTE 2 A high accommodation structure at either stern or bow increases the wind load locally, but in practice the margin of restraint normally provided for a vessel takes care of such eccentric loading.

The height and location of mooring points should be such that vertical angles of mooring lines are as small as practicable and preferably not greater than 25° to the horizontal. The spring lines should be designed to restrain vessel movement along the berth and the breasting lines to restrain the movement off the berth.

The mooring arrangement should accommodate fender positions and quay or dolphin levels in relation to the vessel freeboard range to prevent any wires (particular spring lines) from rubbing against the vessel side, the cope edge or fender panels or chafing on any structures.

The physical nature and layout of the berth or terminal affects the manner in which the mooring objectives are achieved, and the relative position of shore-mounted mooring equipment might result in a pattern of lines that gives a less than optimum restraint capability. In such circumstances the berth designer should inform the operator of the limitations of the mooring system. Such information should be included in the facility operating manual.

7.3.2 Continuous quays

In the case of continuous quays, in order to ensure that the maximum useful load restraint is placed on the vessel with the minimum number of mooring lines, the vessel's mooring arrangement should be such that each rope is as near to the optimum line of action for its intended purpose as is possible. Any proposed mooring layout is dependent on the relative position, spacing and strength of bollards on the quay, which nevertheless should be compatible with and suitable for the size and type of vessel (including its typical mooring equipment) using the berth.

Generally bollards on a quay should be provided at between 15 m and 30 m centres.

If necessary, additional mooring points should be provided, set back from the quay face to cater for storm conditions.

NOTE 1 Typically, the spacing is set to match the beam and pile grid spacing to provide adequate structural support.

NOTE 2 The normal mooring pattern consists of ropes issuing at the extremities of the vessel that make horizontal angles of about 45°, -90° and -45° to its longitudinal axis, plus spring lines at about 10° to its longitudinal axis (see Figure 11).

Figure 11 Typical mooring pattern for continuous quay

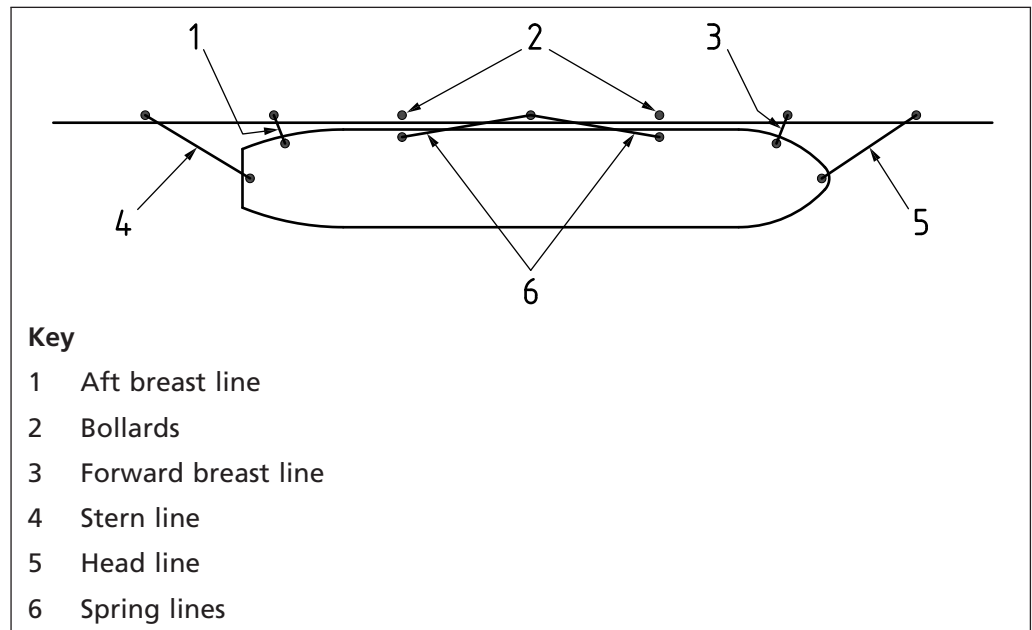

7.3.3 Island or similar type berths

In cases of island, "T" head and similar type berths, mooring points to receive ropes from the ends of the vessels should be placed well behind the berthing face to allow sufficient length to provide elasticity in the system.

A sufficient number of spring lines should be provided for the necessary longitudinal restraint.

For island berths, the transverse and longitudinal forces applied to the vessel should ideally be restrained by breast and spring lines respectively, provided these are set out within the approximate limits given in Figure 12. The mooring points should usually be within the range 35 m to 50 m from the berthing line for the largest vessel.

NOTE 1 Vessels such as LNG/LPG tankers and coastal tankers do not always have their manifolds amidships and do not therefore always lie centrally on the berth. The range of manifold positions relative to midship/loading arm spotting point need to be taken into account in the design of the berth.

NOTE 2 Further guidance for petrochemical vessels is given in OCIMF MEG3 [3].

Figure 12 Optimum angles of mooring lines for island tanker berth

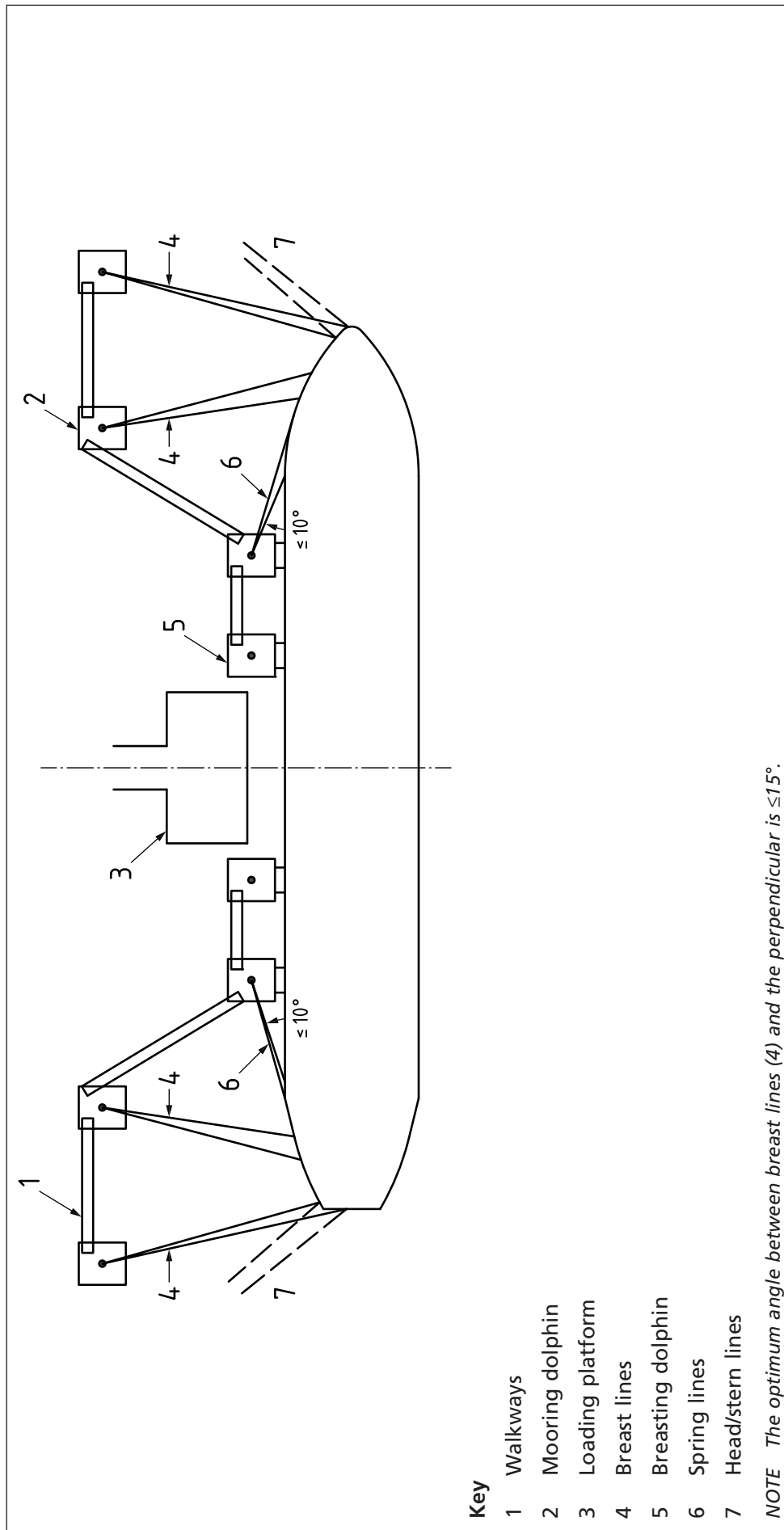

Key

- 1 Walkways
- 2 Mooring dolphin
- 3 Loading platform
- 4 Breast lines
- 5 Breasting dolphin
- 6 Spring lines
- 7 Head/stern lines

NOTE The optimum angle between breast lines (4) and the perpendicular is $\leq 15^\circ$.

8 Actions acting on the moored vessel

8.1 General

The principal horizontal forces acting on a moored vessel are generally caused by wind and current. However, the mooring system should be capable of withstanding any combination of forces resulting from the following as might be applicable, while limiting the vessel's movement to avoid interference with cargo/passenger operations:

- wind load;
- current loads;
- loads due to surge, sway, roll, yaw and related wave-induced movements, including ocean or long swell waves;
- off-quay hydrodynamic force and hydrodynamic interference from passing vessels (see 8.3);
- surge, sway and yaw loads caused by passing vessels in narrow channels;
- tidal rise and fall, and change in draught or trim due to cargo operations;
- vertical movements induced by vessel heave, pitch and roll;
- winch and capstan loads;
- ice and floating debris;
- tug loads.

Accidental loads due to the inappropriate or premature operation of engines or bow thrusters might occur, and the consequences should be identified.

NOTE 1 Further guidance is given in BS 6349-1-1:2013.

NOTE 2 Normally, if the mooring system is designed to accommodate the maximum wind and current forces, the reserve strength is sufficient to resist other forces that may arise under operational conditions. However, if appreciable surge, waves, ice or other abnormal conditions exist at the terminal, considerable loads might be developed in the vessels' moorings.

The selection of the appropriate metocean forces for the design of the berth should take into account the fact that ports might have vessels moored only in normal rather than extreme conditions.

8.2 Wind and currents

Wind and current forces acting on a moored vessel should be evaluated in accordance with BS 6349-1:2000, which also provides guidance on the duration of gusts to be taken into account.⁴⁾

NOTE OCIMF MEG3 [3] gives guidance for tankers, which may be used for vessels with similar size and windage.

8.3 Hydrodynamic forces

NOTE Shore-based tensioning or increased pre-tensioning and alternative mooring systems might be used to reduce vessel movement in appropriate circumstances to increase the cargo handling operational window. The reduction of vessel movement by applying pre-tension to mooring lines can significantly increase the loads in the mooring lines.

⁴⁾ The clauses in BS 6349-1:2000 that deal with loads and actions are expected to form part of the new BS 6349-1-2, which is currently in preparation.

8.3.1 Off-quay hydrodynamic forces

COMMENTARY ON 8.3.1

In circumstances where strong ebb or flood currents are present in the vicinity of the berth, much greater off-berth mooring hydrodynamic forces are generated for berths aligned across the tidal stream rather than parallel due to the large projected area of the vessel.

The obstruction of the high velocity flows under open or piled berth structures slows the water flow under the berth raising the water level. The resultant water surface slope forces the vessel away from the berth, requiring considerable tension in the breasting lines to bring the vessel to the fender face (see Figure 13).

The stand-off force is absorbed only by those mooring lines having an adequate transverse component of resistance of movement of the vessel away from the berth.

If off-quay hydrodynamic forces are likely to occur, they should be assessed with site-specific model testing.

Figure 13 Vessel under influence of stand-off force

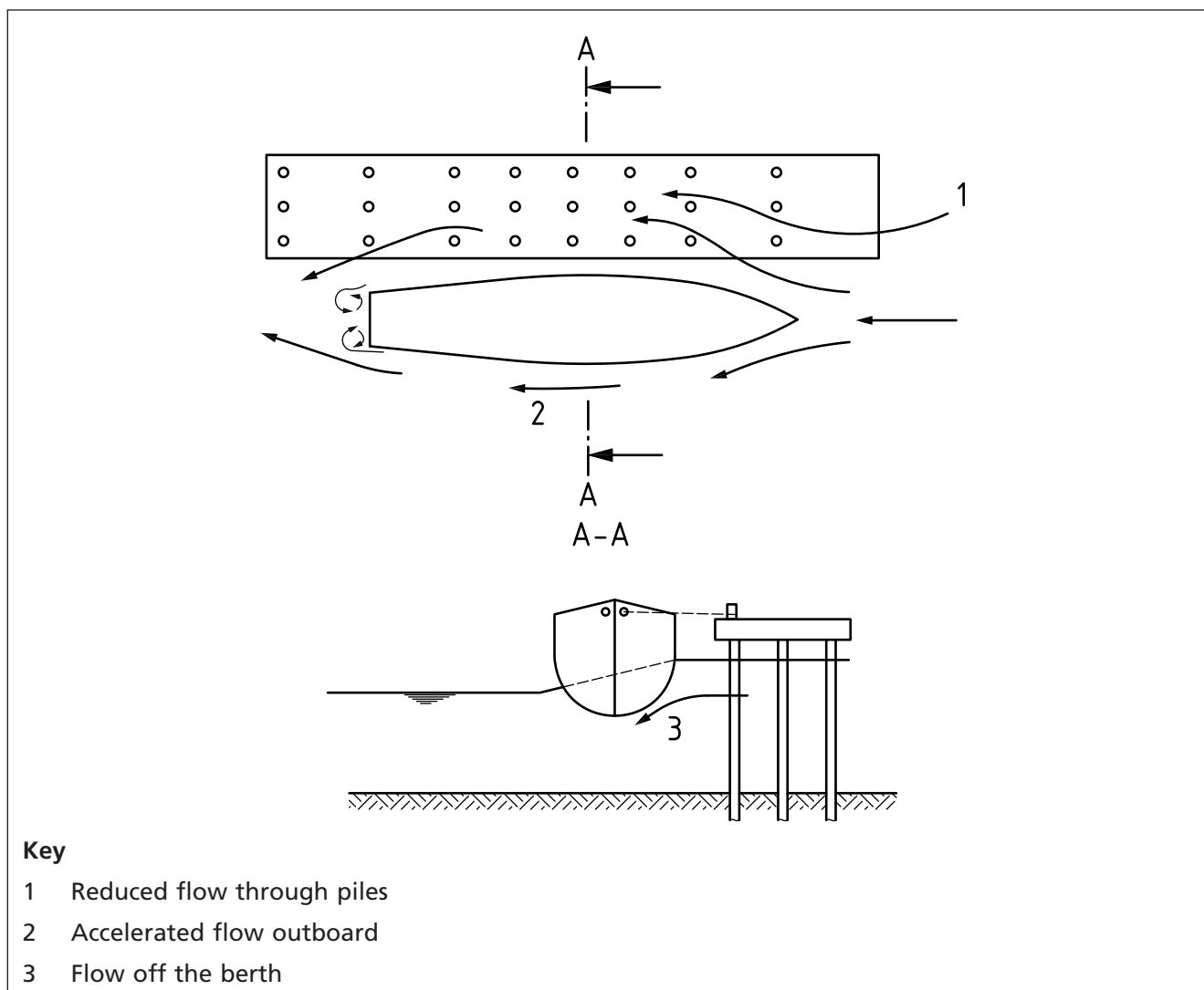

8.3.2 Passing vessel effects

The effects induced by vessels passing in narrow channels should be assessed in accordance with BS 6349-1-1:2013, 19.4.2.

In situations where the effect is of considerable magnitude, the movement caused can lead to cargo-handling disruption and high loadings in the mooring system that could result in failure of ropes or vessel-mounted mooring equipment. If this is the case, specialist advice should be sought.

8.3.3 Long period and infragravity waves

NOTE 1 Long period and infragravity waves can cause large movements of moored vessels. This is due to a combination of the wave period being close to the natural frequency of the moored vessel and the wave length being longer than the vessel's length.

Where vessels are subject to long period and infragravity waves, the effect on the moored vessels should be taken into account, as these can create excessive vessel movement preventing the effective use of the berth under certain conditions.

NOTE 2 Modelling of the moored vessel system might be necessary, as discussed in BS 6349-1-1:2013.

8.4 Tidal rise and fall and change in draught or trim due to cargo operations

The designer should take into account the changing relationship of vessel deck to mooring point level due to:

- a) the loading or unloading of the vessel; and
- b) the changing water level, particularly under tidal conditions.

The designer should take into account the likelihood of the vessel being suspended on the mooring lines on the falling tide or caught under the quay edge or fenders on the rising tide, and should make recommendations as appropriate for the facility operating manual.

NOTE 1 These can induce forces or change the magnitude of loading on the moorings and on the vessel (see Figure 14).

NOTE 2 Mooring lines in tension have a maximum restraining effect when horizontal and are reduced in their restraining effect as the angle from the horizontal is increased.

NOTE 3 Changes in vessel buoyancy due to salinity changes alter the vessel draught and are sometimes significant.

8.5 Ice

The effects of ice on the mooring of a vessel should be taken into account where appropriate.

NOTE When the vessel is moored in ice conditions in a river or estuary, there is the possibility of ice rafting up on and around the vessel and the quay. The drag created by the current on the rafted ice on mooring lines, and around the vessel hull can induce significant moorings loads. The ice loads on the quay also need to be taken into account.

Figure 14 Effect of rise and fall of tide and change in draught or trim

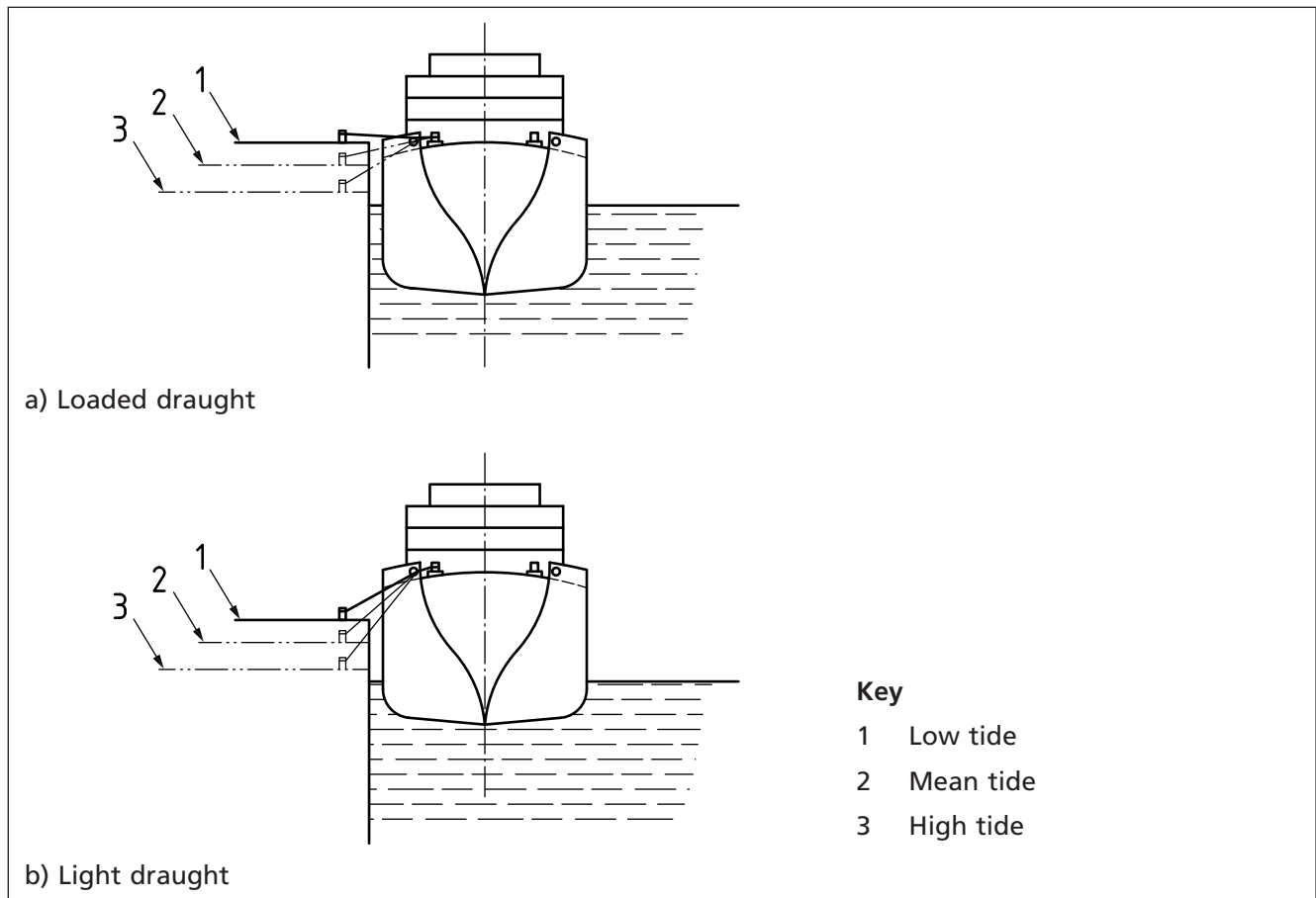

9 Loads on mooring points

9.1 General

The loads on mooring points and lines depend on the actions discussed in Clause 8. The vessel response to waves should be predicted from the known wave climate, taking account of wave period and direction, with special attention to long period waves that might cause very significant movements. Detailed wave studies should be undertaken.

NOTE Recommendations for the estimation of forces as a result of the action of environmental operating conditions on moored vessels are expected to be included in BS 6349-1-2, which is currently in preparation. BS 6349-1-1:2013 gives guidance on the use of mathematical and physical models to estimate the loads.

9.2 Calculation methods

9.2.1 General

Calculations should be carried out to determine the probable maximum loadings on each mooring point. The calculations should take into account the expected range of vessel sizes and the capacity of their mooring equipment. One of the methods described in 9.2.2 to 9.2.6 should be used.

9.2.2 Method 1: Elastic analysis

The wind and current forces on the vessel should be calculated using the method given in BS 6349-1:2000⁵⁾.

The loads on each individual mooring point should then be calculated by treating the mooring lines as an elastic system, using either hand calculation or a computer.

For calculation by hand, the system should be simplified by assuming that the longitudinal forces are resisted by the spring lines and the transverse forces at the bow and stern by the bow and stern breasting lines respectively.

The mooring ropes should be assumed to have the same characteristics, and account should be taken of the lengths and angles of the mooring lines.

9.2.3 Method 2: Simple shared loads

An alternative method of calculating the loads on each individual mooring point is to assume that if the berth has six mooring points then one-third of the total transverse force on the vessel is taken by any one mooring point, and the mooring point should be designed for this force at normal working stresses. The longitudinal forces should be assumed to be resisted entirely by the spring line mooring points.

If the berth has only four mooring points, then one-half of the total transverse force on the vessel should be assumed to be taken by any one mooring point.

9.2.4 Method 3: Working line loads

For vessels less than 20 000 t displacement, or for a particular vessel using specified mooring ropes and mooring pattern, the mooring points should be designed at normal working stresses for a force equal to the minimum breaking load of the ropes.

NOTE Typical rope characteristics are given in IMO MSC/Circ 1175 [4].

9.2.5 Method 4: Computer simulation

A suitable computer simulation program should be used, or physical modelling should be carried out, to predict the wave forces on the vessel and to model the resultant dynamic behaviour of the vessel, taking into account the mooring and fendering system arrangement.

NOTE Further guidance on the simulation is given in BS 6349-1-1:2013.

This method should be adopted for exposed berths where vessels are subject to significant wave forces, or where the interaction between the vessel and the waves is significant.

9.2.6 Method 5: Notional bollard load capacity

For preliminary design of continuous berths, if there is insufficient data to carry out any of the methods described in 9.2.2, 9.2.3, 9.2.4 and 9.2.5, the mooring point loads in Table 5 should be used for general cargo vessels and bulk carriers at a sheltered location.

⁵⁾ The clauses in BS 6349-1:2000 that deal with loads and actions are expected to form part of the new BS 6349-1-2, which is currently in preparation.

Table 5 Mooring point loads for general cargo vessels and bulk carriers

Vessel displacement t	Mooring point load t
20 000 up to and including 50 000	80
Above 50 000 up to and including 100 000	100
Above 100 000 up to and including 200 000	150
Above 200 000	≥200

NOTE Storm bollards may be used in the mooring pattern. These are typically >250 t in capacity.

9.3 Design of mooring point structure

The mooring point loads derived from methods 1 to 5 are horizontal actions. In the design of the mooring point structure and the bollard or hook fixings, account should be taken of the vertical component resulting from the mooring lines not being horizontal.

The mooring equipment should be selected to have a safe working load equal to or greater than the calculated loads.

The mode and type of mooring failure should be assessed to minimize risk to personnel, the vessel and quay structure.

NOTE Generally, the mooring point structure is designed for the rated capacity of the mooring equipment, not the calculated loads. Where a mooring point structure is supporting more than one item of mooring equipment, the designer needs to assess whether it should be designed for the rated capacity of every item of mooring equipment or some lower value. Where several quick release hooks are mounted on one assembly, each hook would be counted as a separate item of mooring equipment.

10 On-shore mooring equipment

NOTE The range of on-shore mooring equipment covered by this part of BS 6349 comprises bollards, quick-release hooks, capstans and vacuum mooring. Fairleads and cleats are not included.

10.1 Materials

NOTE On-shore mooring equipment is generally made from structural steel sections, cast and forged steel and ductile and cast iron.

Materials and the associated workmanship should be in accordance with BS 6349-1-4.

10.2 Mounting and fixing

Mounting systems should be of a design that minimizes maintenance and allows easy replacement of damaged items.

Bolt heads, nuts, etc. should wherever possible be recessed to prevent snagging of mooring lines and to reduce the trip hazard. Bolt recesses result in water ponding, and can induce corrosion, so a suitable filler should be provided to minimize water ingress.

Quick-release hooks on oil, gas or inflammable product jetties should be designed such that they cannot strike the deck and thereby cause sparking. On other installations where quick-release hooks can strike deck surfaces in their released condition, suitable non-structural wearing plates should be provided over the full horizontal arc of travel of the hook assembly.

Where mooring lines bear locally on cope nosings (e.g. lines to small vessels at low tide), suitable anti-wear strips should be provided to protect both the lines and the berth structure.

10.3 Bollards

COMMENTARY ON 10.3

Many bollard designs are commercially available. They can be broadly classified into three categories, as follows:

- pillar type;
- T-head type;
- twin-head type with sloping lobes (also called a stag horn).

These types are illustrated in Table 6 together with characteristics and applications.

Bollards should be fixed and installed to avoid trip and slip hazards to line handlers. The quay surface around the bollard should be fair and well drained to avoid ponding of water and ice in winter. The bolts should be faired over or the bollard set in a recess to avoid obstructions.

No more than two lines should be attached to one bollard unless the bollard has specifically been designed with a longer neck to take three. This should be stated in the facility operating manual.

Table 6 Mooring bollards

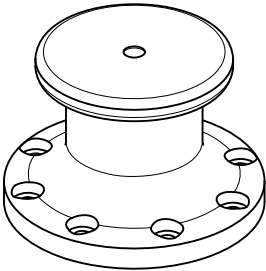
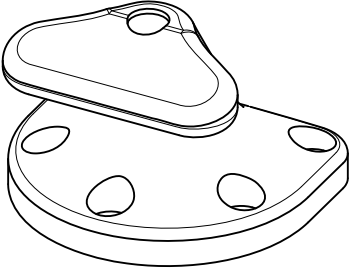
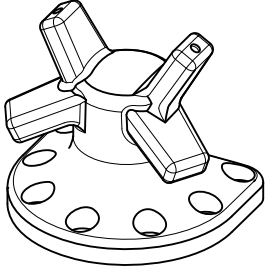
Type		Normal maximum working load t	Applications
Pillar		200 total	General mooring applications where rope angle is not steep Single pillar type should be used with lines from one ship only Suitable for warping ships along berths, etc.
T-head		150	All general mooring applications including steep rope angles Any one bollard should preferably be allocated to lines from one ship only
Stag horn		200 total	All general mooring applications including steep rope angles Lines from two ships may be attached without interference

10.4 Quick release mooring hooks

Hooks should be able to provide an easy and rapid means of releasing mooring lines from berth to vessel under both normal and emergency conditions.

NOTE 1 The release mechanisms might be actuated locally by manual operation or by electromechanical operation from a remote console. Hooks are therefore of particular application to:

- *oil, gas, and chemical berths where quick release of lines for routine departure of vessels might be required;*
- *mooring at island dolphins where personnel access is by launch only;*
- *Ro-Ro berths where a fast turnaround is required and there is a potential for high mooring line loads during unberthing.*

Only one line should be attached to each hook. This should be stated in the facility operating manual.

Remote operation equipment for the individual release of lines should be provided for jetties for VLCCs and large gas carriers.

A centralized remote release for hooks should not be used except when the following criteria are met.

- A detailed risk assessment has been completed indicating that such a system is required and can be safely operated.
- Controls and locking systems, fail-safe systems and release procedures are incorporated in the design and operating procedures to prevent accidental remote release of mooring lines.

NOTE 2 Remote release at the local position is acceptable.

In all cases a safe means of manual release local to the hooks should be provided.

Mooring hooks equipped for remote release should be fitted with adequate safety guards around all moving parts to protect personnel during operating conditions.

NOTE 3 Hooks can be fitted with load monitoring that can be viewed in real time. This can be useful in monitoring pre-tensioning which might be used to limit vessel movement. This can also be useful in monitoring line tension when lines and mooring hooks might exceed their safe working load, and also to give warning in advance of the ships winches paying out line when the winch brake load is exceeded. Where multiple hooks are installed on existing structures, load monitoring can be used to check that the combined mooring loads do not exceed the total design load.

10.5 Capstans

Where mooring lines are too heavy to be attached manually to bollards or mooring hooks, or where there is insufficient space for a large enough mooring gang to operate (e.g. on an island mooring dolphin), electrically driven capstans should be provided for messenger and mooring lines to assist in bringing the vessel's lines ashore.

If a capstan arrangement is installed, an electrically driven capstan with adequate static pull, and which may be started/stopped by means of an operator foot pedal, should be provided.

The foot pedal should have a reversible mode to enable the capstan to be released if a messenger line becomes entangled. The layout should allow for safe operations by personnel. Where necessary, a platform should be installed behind the capstan for the operator to stand on to allow safe handling of the messenger line.

Electric motors for capstans, motor starters, associated cabling and switchgear, together with all electrical equipment for the remote operation of mooring hooks, should have protection characteristics appropriate to the hazardous area classification in which they are situated. Hazardous area classification should be in accordance with BS EN 60079-10-1. All electric cables should be placed in ducts or recessed to avoid creating a tripping hazard in the area where mooring operations are performed.

10.6 Vacuum mooring systems

COMMENTARY ON 10.6

Vacuum mooring systems use vacuum pads in place of mooring bollards. This allows vessels to berth and to moor without the use of mooring lines as the vessel is restrained by the vacuum pads. The time taken to berth and cast off can hence be reduced, increasing port throughput.

As only 1 bar⁶⁾ atmospheric pressure is available, the pads need to be large to provide sufficient mooring force, and the vessel hull has to be sufficiently fair and smooth to provide a suitable bonding surface.

The vacuum pads are attached to the vessel close to the waterline and fixed to the quay edge by hydraulic computer-controlled mooring units. Vacuum pads provide mooring forces and can damp vessel movement, increasing the cargo handling window.

Vacuum moorings might be used where it is important to minimize berth turnaround times, while taking into account the additional maintenance and operation constraints.

The benefit of using vacuum mooring units should be assessed to confirm that the advantages outweigh the additional complexity of installation, operation and maintenance.

Mooring units for vacuum mooring systems, where used, should be designed to allow for the rise and fall of the tide and the draught changes of the vessel during ballasting and loading.

⁶⁾ 1 bar = 10⁵ N/m² = 100 kPa.

Bibliography

Standards publications

BS 6349-1-2, *Maritime works – Part 1-2: General – Code of practice for assessment of actions*⁷⁾

BS 6349-1-3, *Maritime works – Part 1-3: General – Code of practice for geotechnical design*

BS 6349-3, *Maritime structures – Part 3: Design of dry docks, locks, slipways and shipbuilding berths, shiplifts and dock and lock gates*

BS 6349-5, *Maritime structures – Part 5: Code of practice for dredging and land reclamation*

BS 6349-6, *Maritime structures – Part 6: Design of inshore moorings and floating structures*

BS 6349-7, *Maritime structures – Part 7: Guide to the design and construction of breakwaters*

BS 6349-8, *Maritime structures – Part 8: Code of practice for the design of Ro-Ro ramps, linkspans and walkways*

Other publications

- [1] PIANC. *Innovations in navigation – Lock design*. Report No. 106. INCOM WG29. Brussels: PIANC, 2009.
- [2] PIANC. *Guidelines for the design of fender systems*. Report WG33. Brussels: PIANC, 2002.
- [3] OIL COMPANIES INTERNATIONAL MARINE FORUM. *Mooring equipment guidelines*. Third edition (MEG3). London: OCIMF, 2007.
- [4] INTERNATIONAL MARITIME ORGANISATION. *Guidance on shipboard towing and mooring equipment*. IMO MSC/Circ 1175. London: IMO, 2005.

⁷⁾ In preparation.

British Standards Institution (BSI)

BSI is the national body responsible for preparing British Standards and other standards-related publications, information and services.

BSI is incorporated by Royal Charter. British Standards and other standardization products are published by BSI Standards Limited.

About us

We bring together business, industry, government, consumers, innovators and others to shape their combined experience and expertise into standards-based solutions.

The knowledge embodied in our standards has been carefully assembled in a dependable format and refined through our open consultation process. Organizations of all sizes and across all sectors choose standards to help them achieve their goals.

Information on standards

We can provide you with the knowledge that your organization needs to succeed. Find out more about British Standards by visiting our website at bsigroup.com/standards or contacting our Customer Services team or Knowledge Centre.

Buying standards

You can buy and download PDF versions of BSI publications, including British and adopted European and international standards, through our website at bsigroup.com/shop, where hard copies can also be purchased.

If you need international and foreign standards from other Standards Development Organizations, hard copies can be ordered from our Customer Services team.

Subscriptions

Our range of subscription services are designed to make using standards easier for you. For further information on our subscription products go to bsigroup.com/subscriptions.

With **British Standards Online (BSOL)** you'll have instant access to over 55,000 British and adopted European and international standards from your desktop. It's available 24/7 and is refreshed daily so you'll always be up to date.

You can keep in touch with standards developments and receive substantial discounts on the purchase price of standards, both in single copy and subscription format, by becoming a **BSI Subscribing Member**.

PLUS is an updating service exclusive to BSI Subscribing Members. You will automatically receive the latest hard copy of your standards when they're revised or replaced.

To find out more about becoming a BSI Subscribing Member and the benefits of membership, please visit bsigroup.com/shop.

With a **Multi-User Network Licence (MUNL)** you are able to host standards publications on your intranet. Licences can cover as few or as many users as you wish. With updates supplied as soon as they're available, you can be sure your documentation is current. For further information, email bsmusales@bsigroup.com.

BSI Group Headquarters

389 Chiswick High Road London W4 4AL UK

Revisions

Our British Standards and other publications are updated by amendment or revision.

We continually improve the quality of our products and services to benefit your business. If you find an inaccuracy or ambiguity within a British Standard or other BSI publication please inform the Knowledge Centre.

Copyright

All the data, software and documentation set out in all British Standards and other BSI publications are the property of and copyrighted by BSI, or some person or entity that owns copyright in the information used (such as the international standardization bodies) and has formally licensed such information to BSI for commercial publication and use. Except as permitted under the Copyright, Designs and Patents Act 1988 no extract may be reproduced, stored in a retrieval system or transmitted in any form or by any means – electronic, photocopying, recording or otherwise – without prior written permission from BSI. Details and advice can be obtained from the Copyright & Licensing Department.

Useful Contacts:

Customer Services

Tel: +44 845 086 9001

Email (orders): orders@bsigroup.com

Email (enquiries): cservices@bsigroup.com

Subscriptions

Tel: +44 845 086 9001

Email: subscriptions@bsigroup.com

Knowledge Centre

Tel: +44 20 8996 7004

Email: knowledgecentre@bsigroup.com

Copyright & Licensing

Tel: +44 20 8996 7070

Email: copyright@bsigroup.com



...making excellence a habit.™