

# Cycles

## Part 14. Specification for dimensions of bottom bracket axle and crank assembly with square end fittings

## Committees responsible for this British Standard

The preparation of this British Standard was entrusted by the General Mechanical Engineering Standards Policy Committee (GME/-) to Technical Committee GME/25, upon which the following bodies were represented:

Association of Consulting Scientists  
Association of Consumer Research  
Association of Cycle Traders  
Bicycle Association of Great Britain  
British Battery Manufacturers' Association  
British Cycling Federation  
British Rubber Manufacturers' Association  
Consumer Policy Committee of BSI  
Cyclists Touring Club  
Department of Transport  
Institute of Trading Standards Administration  
Royal Society for the Prevention of Accidents  
Small Electrical Appliances Marketing Association  
Individual manufacturers of cycles

This British Standard, having been prepared under the direction of the General Mechanical Engineering Standards Policy Committee, was published under the authority of the Standards Board and comes into effect on 30 September 1991

© BSI 1991

The following BSI references relate to the work on this standard:  
Committee reference GME/25  
Draft for comment 89/70643 DC

ISBN 0 580 20046 9

### Amendments issued since publication

Amd. No.	Date	Text affected

# Contents

	Page
Committees responsible	Inside front cover
National foreword	ii
<hr/>	
<b>Specification</b>	
<b>1</b> Scope	1
<b>2</b> Dimensions	1

---

## National foreword

This Part of BS 6102 has been prepared under the direction of the General Mechanical Engineering Standards Policy Committee and forms part of a series implementing corresponding international standards in the development of which the United Kingdom has played an active part.

This standard is identical with ISO 6695 : 1991 'Cycles — Pedal axle and crank assembly with square end fitting — Assembly dimensions', which was prepared by Technical Committee ISO/TC149 of the International Organization for Standardization (ISO).

*Textual errors.* When adopting the text of the international standard, the textual errors listed below were discovered. They have been marked in the text and have been reported to ISO in a proposal to amend the text of the international standard.

In clause 1, lines 2 to 3, and in clause 2, lines 1 to 2, 'bottom bracket pedal axles' should read 'bottom bracket axles' or 'crank axles'.

**Compliance with a British Standard does not of itself confer immunity from legal obligations.**

## **Cycles — Pedal axle and crank assembly with square end fitting — Assembly dimensions**

### **1 Scope**

This International Standard specifies the dimensions for the assembly of cranks on bottom bracket pedal axles with square end fittings.

### **2 Dimensions**

Dimensions for the assembly of cranks on bottom bracket pedal axles with square end fittings shall be \* as given in figure 1 and table 1.

\* See national foreword for details of textual error.

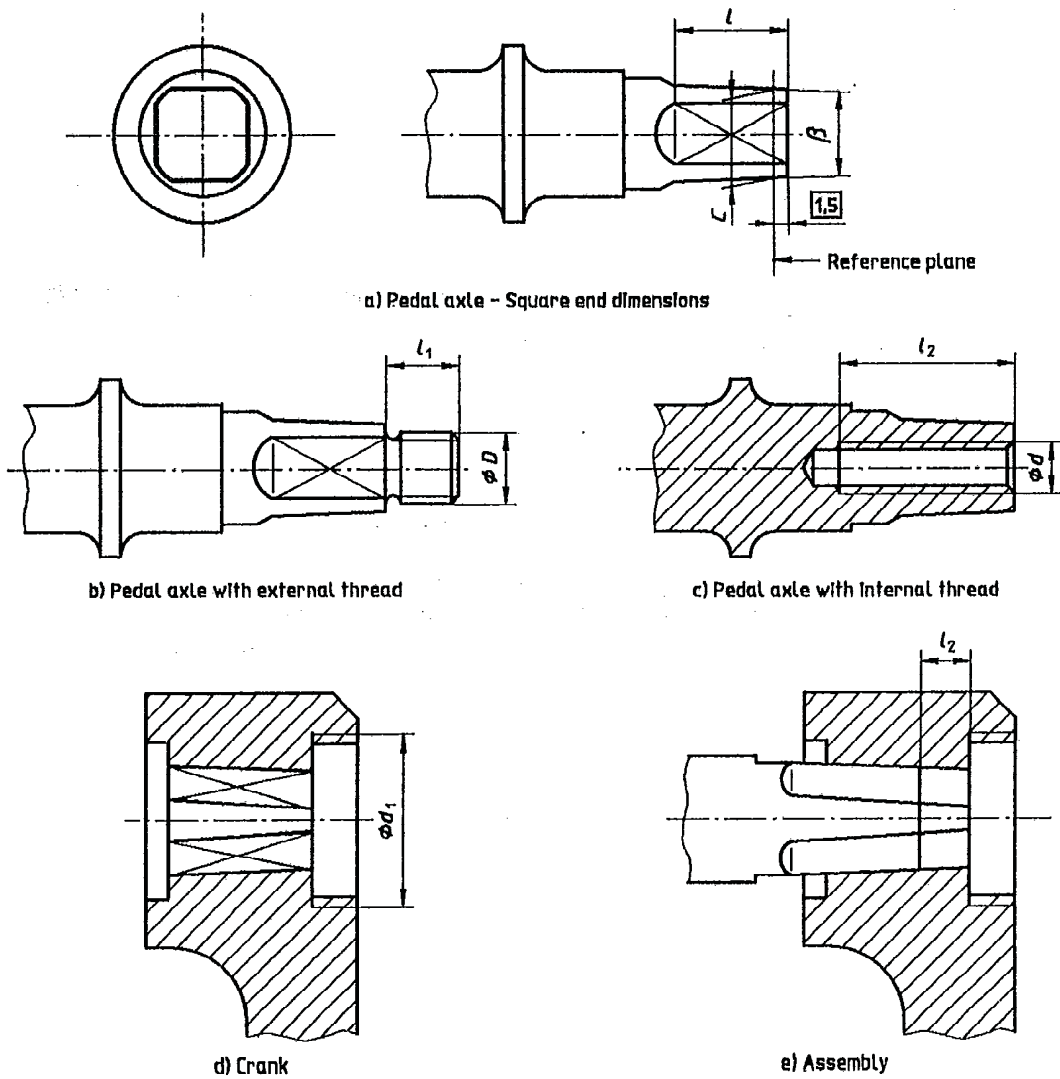

Figure 1

Table 1

Axle							Crank	Assembly	
<i>l</i>		<i>β</i>	<i>c</i>	<i>D</i>	<i>l</i> <sub>1</sub>	<i>d</i>	<i>l</i> <sub>2</sub>	<i>d</i> <sub>1</sub>	<i>l</i> <sub>2</sub> <sup>1)</sup>
Right side	Left side								
16 min.	16 min.	4° ± 0° 10'	12,6 <sup>+0,02</sup> <sub>-0,05</sub>	M10 × 1,25 - 6H/6g	10 <sup>0</sup> <sub>-0,5</sub>	M8 × 1 - 6H/6g	22 min.	M22 × 1 - 6H/6g	1,5 min.

1) After tightening once to the manufacturer's recommended tightening torque.

---

---

## **BSI — British Standards Institution**

BSI is the independent national body responsible for preparing British Standards. It presents the UK view on standards in Europe and at the international level. It is incorporated by Royal Charter.

### **Contract requirements**

A British Standard does not purport to include all the necessary provisions of a contract. Users of British Standards are responsible for their correct application.

### **Revisions**

British Standards are updated by amendment or revision. Users of British Standards should make sure that they possess the latest amendments or editions.

Any person who finds an inaccuracy or ambiguity while using this British Standard should notify BSI without delay so that the matter may be investigated swiftly.

BSI offers members an individual updating service called PLUS which ensures that subscribers automatically receive the latest editions of standards.

### **Buying British Standards**

Orders for all British Standard publications should be addressed to the Sales Department at Milton Keynes.

### **Information on standards**

BSI provides a wide range of information on national, European and international standards through its Library, the Standardline Database, the BSI Information Technology Service (BITS) and its Technical Help to Exporters Service. Contact Customer Information at Milton Keynes: Tel: 0908 221166.

Subscribing members of BSI are kept up to date with standards developments and receive substantial discounts on the purchase price of standards. For details of these and other benefits contact the Manager, Membership Development at Milton Keynes: Tel: 0908 220022.

### **Copyright**

Copyright subsists in all BSI publications. No part of this publication may be reproduced in any form without the prior permission in writing of BSI. This does not preclude the free use, in the course of implementing the standard, of details such as symbols and size, type or grade designations. Enquiries about copyright should be made to the Copyright Manager, Marketing at Milton Keynes.

BSI  
2 Park Street  
London  
W1A 2BS

BSI  
Linford Wood  
Milton Keynes  
MK14 6LE