

Measurement of airborne noise from hydraulic fluid power systems and components —

Part 2: Method of test for motors

Committees responsible for this British Standard

The preparation of this British Standard was entrusted by the Machinery and Components Standards Policy Committee (MCE/-) to Technical Committee MCE/18, upon which the following bodies were represented:

Advanced Manufacturing Technology Research Institute
 Association of British Mining Equipment Companies
 Bath University
 British Compressed Air Society
 British Fluid Power Association
 British Steel Industry
 Department of Trade and Industry (National Engineering Laboratory)
 Ministry of Defence

The following bodies were also represented in the drafting of the standard, through subcommittees and panels:

British Hydromechanics Research Association
 British Railways Board
 Society of Motor Manufacturers and Traders Ltd.

This British Standard, having been prepared under the direction of the Machinery and Components Standards Policy Committee, was published under the authority of the Standards Board and comes into effect on 15 December 1992

© BSI 02-2000

First published November 1980
 Second edition December 1992

The following BSI references relate to the work on this standard:
 Committee reference MCE/18
 Draft for comment 89/78172 DC

ISBN 0 580 21396 X

Amendments issued since publication

Amd. No.	Date	Comments

Contents

	Page
Committees responsible	Inside front cover
National foreword	ii
<hr/>	
Introduction	1
1 Scope	1
2 Normative references	1
3 Definitions	1
4 Measurement uncertainty	2
5 Test environment	2
6 Instrumentation	2
7 Installation conditions	2
8 Operating conditions	3
9 Location and number of sound measurement points	3
10 Test procedure	3
11 Information to be recorded	4
12 Test report	5
13 Identification statement (Reference to this part of ISO 4412)	5
<hr/>	
Annex A (normative) Calculation of sound levels	6
Annex B (normative) Errors and classes of measurement	6
Annex C (informative) Guidelines for the application of this part of ISO 4412	6
Annex D (informative) Bibliography	16
<hr/>	
Figure C.1 — Transmission paths of sound energy from motors	7
Figure C.2 — Instrumentation for manual data logging	8
Figure C.3 — Multiple microphone scanning instrumentation	9
Figure C.4 — Corrections for background noise	10
Figure C.5 — Motor noise test configuration with hemispherical measuring array	11
Figure C.6 — Mounting and driveline arrangement for hemispherical measurement	11
Figure C.7 — “Minimized” motor mount (two-bolt flange mounting configuration)	13
Figure C.8 — Diagrammatic view of the hemispherical layout showing fluid line cladding	14
Figure C.9 — Example of test circuit	16
<hr/>	
Table 1 — Standard deviation of sound power level determinations	2
Table 2 — Allowable variations of mean indicated values of controlled parameters	3
Table B.1 — Permissible systematic errors of measuring instruments as determined during calibration	6
List of references	Inside back cover
<hr/>	

National foreword

This Part of BS 5944 has been prepared under the direction of the Machinery and Components Standards Policy Committee. It is identical with ISO 4412-2:1991 *Hydraulic fluid power — Test code for determination of airborne noise levels — Part 2: Motors*, published by the International Organization for Standardization (ISO).

On publication of BS 5944-1:1992 and BS 5944-2:1992, the 1980 editions of BS 5944-1, BS 5944-2 and BS 5944-3 will be withdrawn.

BS 5944 comprises the following Parts.

- *Part 1: Method of test for pumps;*
- *Part 2: Method of test for motors;*
- *Part 3: Withdrawn;*
- *Part 4: Method of determining sound power levels from valves controlling flow and pressure;*
- *Part 5: Simplified method of determining sound power levels from pumps using an anechoic chamber;*
- *Part 6: Method of test for pumps using parallelepiped microphone array.*

For the purposes of the British Standard the identification statement required by clause 13 may be replaced by the following:

“Airborne noise levels determined in accordance with BS 5944-2”

Cross-references

International Standard	Corresponding British Standard
ISO 3019-2:1986	BS 6276:1987 <i>Specification for dimensions and identification code for mounting flanges and shaft ends for hydraulic fluid power pumps and motors</i> (Technically equivalent)
ISO 3488:1975	BS 4231:1982 <i>Classification for viscosity grades of industrial liquid lubricants</i> (Identical)
ISO 3744:1981	BS 4196 <i>Sound power levels of noise sources</i> Part 4:1981 <i>Engineering methods for determination of sound power levels for sources in free-field conditions over a reflecting plane</i> (Identical)
ISO 3745:1977	Part 5:1981 <i>Precision methods for determination of sound power levels for sources in anechoic and semi-anechoic rooms</i> (Identical)
ISO 6743-4:1982	BS 6413 <i>Lubricants, industrial oils and related products (Class L)</i> Part 4:1983 <i>Classification for family H (hydraulic systems)</i> (Identical)
IEC 50(801):1984	BS 4727 <i>Glossary of electrotechnical, power, telecommunication, electronics, lighting, and colour terms</i> Part 3: Group 08:1985 <i>Acoustics and electroacoustics terminology</i> (Technically equivalent)
IEC 651:1979	BS 5969:1981 <i>Specification for sound level meters</i> (Identical)

The Technical Committee has reviewed the provisions of ISO 2204:1979 and ISO 5598:1985 to which reference is made in the text and has decided that they are acceptable for use in conjunction with this standard.

There are no corresponding British Standards for ISO 2204 or ISO 5598.

A British Standard does not purport to include all the necessary provisions of a contract. Users of British Standards are responsible for their correct application.

Compliance with a British Standard does not of itself confer immunity from legal obligations.

Summary of pages

This document comprises a front cover, an inside front cover, pages i to iv, pages 1 to 16, an inside back cover and a back cover.

This standard has been updated (see copyright date) and may have had amendments incorporated. This will be indicated in the amendment table on the inside front cover.

Introduction

In hydraulic fluid power systems, power is transmitted and controlled through a liquid under pressure in an enclosed circuit. Motors are components which convert rotary fluid power to mechanical power. During the process of converting hydraulic fluid power to mechanical power, airborne noise, fluid-borne vibrations and structure-borne vibrations are radiated from the motor.

The airborne noise level of a hydraulic fluid power motor is an important consideration in component selection. The noise measurement technique must, therefore, be such as to yield accurate appraisals of these airborne noise levels. The determination of noise levels is complicated by the interactions which occur during noise measurements. The fluid-borne vibrations from the motor can be transmitted to the circuit and ultimately give rise to background airborne noise levels which could affect the determination of the motor airborne noise levels.

The procedures described in this part of ISO 4412 are intended to measure only the airborne noise radiated directly from the motor under test.

1 Scope

This part of ISO 4412 establishes a test code describing procedures, based on ISO 2204, for the determination of the sound power levels of a hydraulic fluid power motor, under controlled conditions of installation and operation, suitable for providing a basis for comparing the noise levels of motors in terms of:

- A-weighted sound power level;
- octave band sound power levels.

From these sound power levels, if required, reference sound pressure levels may be calculated for reporting purposes in accordance with Annex A.

For general purposes, the frequency range of interest includes the octave bands with centre frequencies between 125 Hz and 8 000 Hz.¹⁾

Due to the inherent difficulties in the measurement of low-speed motor performance, this part of ISO 4412 is limited to motors operating at speeds exceeding 50 r/min.

Guidelines for the application of this part of ISO 4412 are given in Annex C.

This part of ISO 4412 is applicable to all types of hydraulic fluid power motors operating under steady-state conditions, irrespective of size, except for any limitations imposed by the size of the test environment (see clause 5).

¹⁾ 1 Hz = 1 s⁻¹

2 Normative references

The following standards contain provisions which, through reference in this text, constitute provisions of this part of ISO 4412. At the time of publication, the editions indicated were valid. All standards are subject to revision, and parties to agreements based on this part of ISO 4412 are encouraged to investigate the possibility of applying the most recent editions of the standards indicated below. Members of IEC and ISO maintain registers of currently valid International Standards.

ISO 3448:1975, *Industrial liquid lubricants — ISO viscosity classification*.

ISO 3744:1981, *Acoustics — Determination of sound power levels of noise sources — Engineering methods for free-field conditions over a reflecting plane*.

ISO 3745:1977, *Acoustics — Determination of sound power levels of noise sources — Precision methods for anechoic and semi-anechoic rooms*.

ISO 5598:1985, *Fluid power systems and components — Vocabulary*.

ISO 6743-4:1982, *Lubricants, industrial oils and related products (class L) — Classification — Part 4: Family H (Hydraulic systems)*.

IEC 50(801):1984, *International Electrotechnical Vocabulary — Chapter 801: Acoustics and electroacoustics*.

IEC 651:1979, *Sound level meters*.

3 Definitions

For the purposes of this part of ISO 4412, the definitions given in ISO 5598, IEC 50 and the following definitions apply. It is accepted that the latter definitions may differ from those in other specific International Standards.

3.1 free sound field

sound field in a homogeneous, isotropic medium free of boundaries

NOTE 1 In practice, it is a field in which the effects of the boundaries are negligible over the frequency range of interest.

3.2 free field over a reflecting plane

field produced by a source in the presence of one reflecting plane on which the source is located

3.3 reverberant sound field

that portion of the sound field in a test room over which the influence of sound received directly from the source is negligible

3.4 anechoic room

a test room having boundaries which absorb essentially all of the incident sound energy over the frequency range of interest, thereby affording free-field conditions over the measurement surface

3.5 mean-square sound pressure

the sound pressure averaged in space and time on a mean-square basis

NOTE 2 In practice, this is estimated by space and time averaging over a finite path length or over a number of fixed microphone positions.

3.6 mean sound pressure level

ten times the logarithm to the base 10 of the ratio of the mean-square sound pressure to the square of the reference sound pressure, in decibels (dB)

NOTE 3 The weighting network or the width of the frequency band used should always be indicated; for example, A-weighted sound pressure level, octave band sound pressure level. The reference sound pressure is $20 \mu\text{Pa}^2$.

3.7 sound power level

ten times the logarithm to the base 10 of the ratio of a given sound power to the reference sound power, in decibels

NOTE 4 The weighting network or the width of the frequency band used should always be indicated. The reference sound power is 1 pW^3 .

3.8 volume of source under test

volume of the envelope of the whole motor under test

4 Measurement uncertainty

Methods of measurement should be used which tend to result in standard deviations which are equal to or less than those specified in Table 1. Methods given in ISO 3744 meet this requirement.

Table 1 — Standard deviation of sound power level determinations

Standard deviation, dB, for octave bands centred on:				
125 Hz	250 Hz	500 Hz	1 000 Hz to 4 000 Hz	8 000 Hz
5,0	3,0	2,0	2,0	3,0

²⁾ $1 \mu\text{Pa} = 10^{-6} \text{ N/m}^2$

³⁾ $1 \text{ pW} = 10^{-12} \text{ W}$

The standard deviations given in Table 1 include the effects of allowable variations in the positioning of the measurement points and in the selection of any prescribed measurement surface, but exclude variations in the sound power output of the source from test to test.

NOTE 5 The A-weighted sound power level will in most practical cases be determined with a standard deviation of approximately 2 dB.

5 Test environment

Tests shall be conducted in an environment which provides “free-field over a reflecting plane” or “special reverberant” conditions which meet the environmental qualification requirements described in ISO 3744:1981, clause 4 and Annex A.

For more precise measurements, conduct tests in accordance with ISO 3745.

6 Instrumentation

6.1 The instrumentation used to measure fluid flow, fluid pressure, motor speed and fluid temperature shall be in accordance with the recommendations for “industrial class” accuracy of testing; i.e. class C given in Annex B.

6.2 The instrumentation used for acoustical measurements shall be in accordance with IEC 651. This instrumentation shall be in accordance with ISO 3744 for both performance and calibration; i.e. type 2 instruments for engineering (grade 2) measurements.

7 Installation conditions

7.1 Motor location

The motor may be located in any position consistent with the source installation and measurement surface (or microphone traverse) requirements specified in ISO 3744 for the test environment being used.

7.2 Motor mounting

7.2.1 The motor mounting shall be constructed so that it will minimize the noise radiated by the mounting as a result of motor vibrations.

7.2.2 The mounting bracket shall be constructed of high-damping material or with sound-damping and sound-insulating material applied to the bracket as required.

7.2.3 Vibration isolation techniques, if needed, shall be used even if the motor is usually securely mounted.

7.2.4 Flange mountings that are as small as practical shall be used so as to minimize interference with radiation of sound towards the shaft end of the motor.

7.3 Motor-driven load

The load system shall be located outside the test space and the load shall be driven through flexible couplings and an intermediate shaft, or the load system shall be isolated in an acoustic enclosure.

7.4 Hydraulic circuit

7.4.1 The circuit shall include all oil filters, oil coolers, reservoirs and restrictor valves as required to meet the motor hydraulic operating conditions (see clause 8).

7.4.2 The test fluid and degree of filtration shall be in accordance with the motor manufacturer's recommendations.

7.4.3 Inlet and discharge lines shall be installed with diameters in accordance with the manufacturers' recommended practice.

7.4.4 The outlet pressure gauge shall be mounted at the same height as the outlet fittings or it shall be calibrated for any height difference.

7.4.5 Pressure fluctuations and standing waves in the inlet and outlet ports shall be minimized by such measures as selected line lengths, long lengths of flexible hose, accumulators, inline silencers and inline pulsation pumps.

7.4.6 A stable load valve shall be used in the outlet line if back pressure is regulated.

NOTE 6 Unstable load valves in the lines can generate and transmit noise through the fluid and piping which can emerge as airborne sound at the motor.

7.4.7 Any control valves shall be positioned far from the motor, preferably outside the test room, to minimize the interaction.

7.4.8 All fluid lines and valves in the test space shall be wrapped with sound-isolating materials, if required (see 10.1). Material having a sound-transmission loss of at least 10 dB at 125 Hz, and a greater loss at higher frequencies, shall be used.

8 Operating conditions

8.1 Determine the sound power levels of the motor for any desired set of operating conditions (see 11.3.7).

8.2 These test conditions shall be maintained throughout the test within the limits given in Table 2.

Table 2 — Allowable variations of mean indicated values of controlled parameters

Test parameter	Allowable variation
Pressure	$\pm 2\%$
Speed	$\pm 2\%$
Temperature	$\pm 2\text{ }^{\circ}\text{C}$
Torque	$\pm 2\%$

8.3 The motor shall be tested in the "as-delivered" condition with any ancillary equipment operating normally during the test, so as to include their noise contributions to the airborne noise level of the motor.

9 Location and number of sound measurement points

The location and number of measurement points shall be as required by ISO 3744 for the method of measurement selected for the motor noise test.

10 Test procedure

10.1 Background noise measurements

10.1.1 Measure the background noise of interest that is present during the motor noise test which does not emanate from the motor itself.

Over the frequency range of interest, the band sound pressure levels of this background noise shall be at least 6 dB below the motor band sound pressure levels at each measurement point.

10.1.2 Correct for this background noise, if evidenced by these measurements, by applying the corrections for this purpose given in ISO 3744.

10.1.3 When measurement of band levels of background noise is not practical, the A-weighted background sound level of each measurement point shall be at least 6 dB below the motor A-weighted sound level.

Correct these A-weighted measurements for background noise.

NOTE 7 Easing the requirements for background noise levels can lead to an overestimate of the motor band sound pressure levels.

NOTE 8 The A-weighted background sound level at each measurement point may be checked by covering the motor with sound-insulating materials capable of a transmission loss of at least 10 dB over the frequency range which is "determining" the A-weighted sound level of the motor.

10.1.4 If the background level is found to be too high, check for further noise control of the motor mounting, driven load or hydraulic circuit, as indicated.

10.1.5 Ensure that the orientation of the microphone and the period of observation are as specified in ISO 3744.

10.2 Motor measurements

10.2.1 Measurement sequence

Prior to commencement of a series of tests, operate the motor for a sufficient time to purge air from the system and to stabilize all variables, including fluid condition, to within the limits specified in Table 2.

Measure the following for each test:

- motor speed;
- output torque;
- fluid temperature and pressure at motor inlet and fluid pressure at discharge fittings or at the test point provided by the motor manufacturer;
- band sound pressure levels at each measurement point over the frequency range of interest;
- A-weighted sound pressure level at each measurement point.

10.2.2 New or rebuilt motors

10.2.2.1 Repeat the initial motor measurement test of the series at the end of a test series or after 1 h of testing.

10.2.2.2 If the A-weighted sound level at any selected measurement point does not duplicate that of the first test within 2 dB (A), the whole test series shall be invalidated.

11 Information to be recorded

11.1 Specifications

The information given in 11.2 and 11.3 shall be compiled and recorded for all measurements made according to the requirements of this part of ISO 4412.

11.2 General information

- name and address of the motor manufacturer and, if applicable, the user;
- reference number(s) for identification of the motor;
- name and address of persons or organization responsible for the acoustic tests on the motor;
- date and place of acoustic tests;
- statement that the sound power levels of the motor have been obtained in full conformance with this part of ISO 4412 and ISO 3744 for the determination of sound power levels of noise sources (see also clause 13).

11.3 Motor under test

11.3.1 Description of motor

- type of motor (e.g. gear or piston), including ancillary equipment;
- type of displacement (e.g. fixed or variable);
- motor overall linear dimensions (with sketch if necessary);
- motor maximum displacement;
- type of displacement controller and setting.

11.3.2 Acoustic environment for tests

- internal dimensions of the test room and the type of acoustic field for the measurements (e.g. free field over a reflecting plane);
- the acoustical treatment of the test room;
- the date of measurement;
- ambient air temperature (in degrees Celsius), relative humidity (in percentage) and barometric pressure (in pascals⁴⁾);
- results of acoustical qualification of test environments as required by clause 5.

11.3.3 Reference sound source (when applicable)

- manufacturer, type and serial number;
- sound power level calibration data, including name of calibrating laboratory and date of calibration.

11.3.4 Mounting and installation conditions of motor

- description of motor mounting conditions;
- nature and characteristics of the hydraulic circuit and details of any acoustic insulation treatment;
- nature and description of other machines being used which could have an influence on the measured sound pressure levels of the motor.

11.3.5 Location of motor in test environment

11.3.5.1 Include a sketch showing the location of the motor in relation to walls, floor and ceiling of the test room.

11.3.5.2 Show on this sketch the location of other reflecting or absorbing screens and noise sources which can influence measurements.

11.3.6 Instrumentation

- details of equipment used to monitor motor operating conditions (see 11.3.7), including type, serial number and manufacturer;
- details of equipment used for acoustic measurements including name, type, serial number and manufacturer;

⁴⁾ 1 Pa = 10⁻⁵ bar

- c) bandwidth of frequency analyser;
- d) overall frequency response of instrumentation system and date and method of calibration;
- e) method of calibration of microphones and date and place of calibration.

11.3.7 Motor operating conditions

Include the following details for each test:

- a) full description of fluid, including classification in accordance with ISO 6743-4;
- b) fluid viscosity classification in accordance with ISO 3448, in centistokes or in square millimetres per second⁵⁾;
- c) shaft speed, in revolutions per minute;
- d) output torque, in newton metres;
- e) inlet pressure, in megapascals (bars⁶⁾);
- f) outlet pressure, in megapascals (bars);
- g) temperature of fluid at motor inlet, in degrees Celsius.

11.3.8 Acoustical data

Include all data as required by ISO 3744.

12 Test report

The test report shall contain the following information:

- a) the A-weighted sound power level and octave band sound power levels for each frequency band of interest for each set of operating conditions;
- b) a statement that the sound power levels have been obtained in full conformance with the procedures of this part of ISO 4412 and specific paragraphs of ISO 3744 for the determination of sound power levels of noise sources.

13 Identification statement (Reference to this part of ISO 4412)

Use the following statement in test reports, catalogues and sales literature when electing to comply with this part of ISO 4412:

“Airborne noise levels determined in accordance with ISO 4412-2, *Hydraulic fluid power — Test code for determination of airborne noise levels — Part 2: Motors*”.

⁵⁾ 1 cSt = 1 mm²/s

⁶⁾ 1 bar = 10⁵ N/m² = 10⁵ Pa = 0,1 MPa

Annex A (normative) Calculation of sound levels

A.1 Calculation of motor mean sound pressure levels and sound power levels

A.1.1 Refer to ISO 3744 for information regarding corrections to be applied and the method of calculating the mean levels and the motor sound power levels.

A.1.2 Correct the measured band sound pressure levels (and A-weighted sound levels, where appropriate) at each measurement position for the measured background noise (background noise corrections).

A.1.3 Use these corrected levels to calculate the motor mean band sound levels and mean A-weighted sound level.

A.1.4 Calculate the motor sound power level from these mean sound pressure levels, taking into account any correction for unwanted environmental reflections (environmental correction factor).

A.2 Calculation of mean sound pressure level at a reference distance

The mean sound pressure level at a distance r , in metres, from the equivalent point source radiating into a free field over a reflecting plane (hemispherical radiation) from the calculated motor sound power level is evaluated as follows:

$$\bar{L}_p = L_W - 10 \log[2\pi r^2/S_0]$$

where

\bar{L}_p is the mean sound pressure level, A-weighted or in bands, in decibels (reference: 20 μ Pa);

L_W is the A-weighted or band power level of the motor under test, in decibels (reference: 1 pW);

$2\pi r^2$ is the area of the hemisphere, in square metres, of radius r ;

$$S_0 = 1 \text{ m}^2.$$

For calculation purposes, choose a reference distance of $r = 1$ m, in which case the numerical value of \bar{L}_p is obtained by subtracting 8 dB from the numerical value of the calculated sound power level, L_W .

Annex B (normative) Errors and classes of measurement

B.1 Classes of measurement

Depending on the accuracy required, the tests may be carried out to one of three classes of measurement, A, B or C. The classes of measurement shall be agreed between the parties concerned. The use of class A and B is restricted to special cases when there is a need to have the performance more precisely defined. Class A and B tests require more accurate apparatus and methods, which may increase the costs of such tests.

B.2 Errors

Any device or method which by calibration or comparison with International Standards has been demonstrated to be capable of measuring with systematic errors not exceeding the limits in Table B.1 may be used.

Table B.1 — Permissible systematic errors of measuring instruments as determined during calibration

Class of measurement	Units	A	B	C
Input signal	%	$\pm 0,5$	$\pm 1,5$	$\pm 2,5$
Flow	%	$\pm 0,5$	$\pm 1,5$	$\pm 2,5$
Pressure	%	$\pm 0,5$	$\pm 1,5$	$\pm 2,5$
Temperature	$^{\circ}\text{C}$	$\pm 0,5$	$\pm 1,0$	$\pm 2,0$
Speed	%	$\pm 0,5$	$\pm 1,0$	$\pm 2,0$
Torque	%	$\pm 0,5$	$\pm 1,0$	$\pm 2,0$

NOTE The percentage limits given are of the value of the quantity being measured and not of the maximum values of the test or the maximum reading of the instrument.

Annex C (informative) Guidelines for the application of this part of ISO 4412

C.1 Introduction

This annex describes a series of recommended techniques that are designed to enable reliable measurements of hydraulic motor airborne noise to be taken, using an anechoic chamber, in accordance with this part of ISO 4412.

C.2 General

This annex should be read in conjunction with ISO 2204 and ISO 3744.

The principle of this part of ISO 4412 is based on measurements taken over a hemispherical surface centred over the motor unit under test. It does, however, present certain operational difficulties. The methods outlined in this annex represent a practical solution to these problems and allow compliance with the requirements of this part of ISO 4412.

In a hydraulic installation, the vibrational energy of the motor becomes distributed among other components in the system, such as the connecting pipe-work, the motor mounting, the output shaft and the load. This distribution of energy is a characteristic of the particular installation and is not inherently a measure of motor noise. The motor, however, produces sound energy which can cause the installation as a whole to emit noise. Figure C.1 illustrates the mechanism. It is the objective of this annex to ensure that the measured noise is that radiated by the external surface of the motor and nothing else. This component of noise will then be genuinely a characteristic of the motor and as little affected as possible by the particular installation.

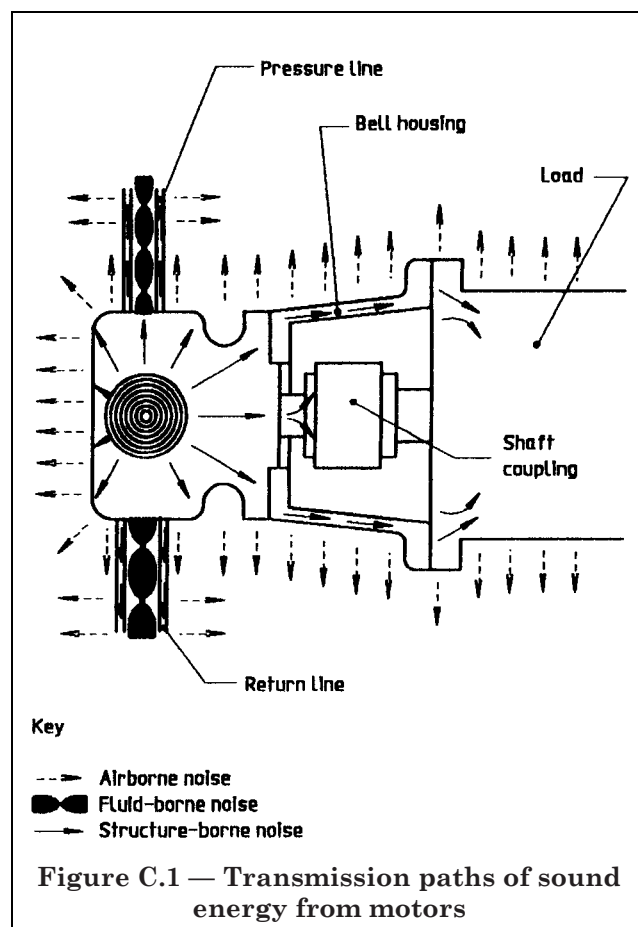

The total airborne noise of a practical installation includes radiation from all the components of the hydraulic system. These are excited, in the main, by pump- and motor-generated fluid-borne noise (pressure ripple) present in the circuit and by structural transmission of vibration from the pump and motor to attached components.

These mechanisms may well predominate in the generation of total system noise. It is found, however, that low airborne noise radiation from the motor surface tends to be associated with low fluid-borne and structural noise generation. The values obtained for airborne noise radiation from the surface of a motor may thus be taken as an indication, but not an exact measure, of its overall acoustic performance.

C.3 Choice of measurement environment

This part of ISO 4412 permits measurement in a reverberant or an anechoic room. The anechoic room may take the form of a fully free-field environment or a free field over a single reflecting plane, termed a "semi-anechoic chamber".

An anechoic or semi-anechoic room is normally preferable for motor testing work because there are fewer measurement uncertainties associated with the strongly periodic noise typically radiated by motors. Anechoic or semi-anechoic environments also allow directivity information to be obtained which, though not required by this part of ISO 4412, can provide valuable assistance when setting up a system or diagnosing motor acoustic output.

Although a reverberant room is the least affected by accidental oil spillage, the acoustic advantages of an anechoic or semi-anechoic room are frequently more important. Oil spillage in a semi-anechoic room is less serious than in a fully anechoic room if the floor is used as the reflecting plane.

The following discussion relates only to the use of anechoic or semi-anechoic test environments.

C.4 Measurement techniques

C.4.1 Microphones

High-quality condenser microphones, complying with the requirements of the appropriate International Standards listed in ISO 3744 are required to measure the sound pressure levels in the anechoic chamber. The profile of the microphones, connecting leads and support frame should be minimized to reduce interference with the sound field. The sound level meter is placed outside the chamber, and is connected to the microphone via a pre-amplifier and extension lead. A typical set-up, with two microphones connected via a common power supply, is shown in Figure C.2.

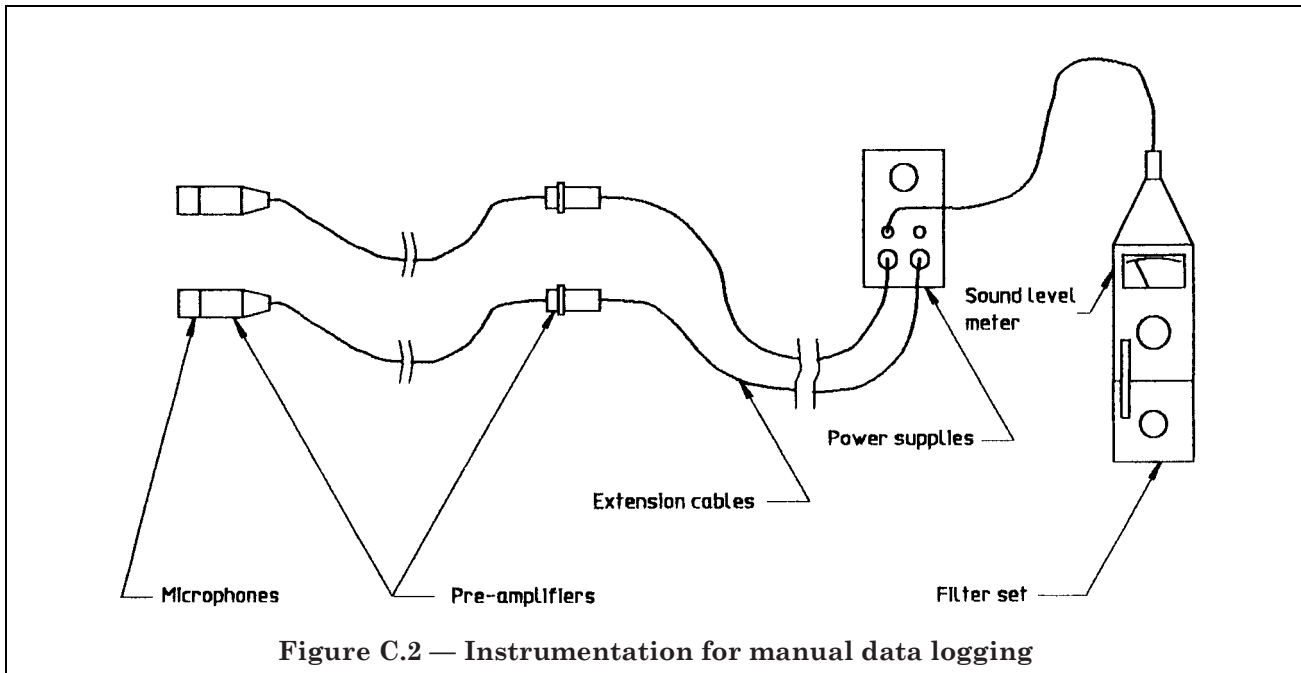

Figure C.2 — Instrumentation for manual data logging

C.4.2 Number and position of microphones

In order to obtain a valid estimate of the mean sound pressure, the sound field has to be sampled at several points over the measurement surface. A basic array of 10 points is called for, but this number may be reduced if experience shows that the sound field is sufficiently symmetrical for the resultant loss in accuracy not to give errors greater than 1 dB when compared with data obtained using the full array.

As a guide, use at least as many microphones as there is difference between the lowest and highest sound pressure levels, in decibels, recorded on the individual microphones.

Each sampling point should be associated with an equal area of the measurement surface and should be placed in a sequence that minimizes the effect of interference patterns. ISO 3744 gives relative coordinates and preferred radii for suitable hemispherical arrays. Sources with the dimensions of a normal fluid power motor usually require a measurement radius of 1 m and frequently greater. Avoid microphone positions close to necessary ancillary equipment such as the motor output shaft and fluid lines, and ensure that, as far as possible, each microphone has a clear "line of sight" to the motor under test.

It is possible to use a single microphone, moving it to each sampling point in sequence, but it is usually more economic to invest in one microphone channel per measurement point.

C.4.3 Calculation of mean sound pressure

The mean sound pressure can be calculated from equations 1 and 2 in ISO 3744:1981.

C.4.4 Recording instruments

The microphones may be directly connected to individual sound level meters, but this is a rather uneconomic use of expensive equipment. Used in conjunction with microphone power supplies, which allow individual microphone gain adjustment, each channel may be fed into a single meter via a manual selector switch.

Either technique involves a considerable amount of manual data logging. For example, 168 data records are required to obtain a one-third octave spectrum from an eight-microphone array covering the range 100 Hz to 10 kHz. If directivity information is not required, it is possible to multiplex the channels into a time-integrating r.m.s. meter. The maximum scan speed is limited by the lowest frequency of interest. Normally a scan speed of 10 channels per second is satisfactory for frequencies of 100 Hz and above.

The scanning device has to operate with very low level switching transients if the background electronic noise is not to influence the sound signal. A typical set-up is shown in Figure C.3. This arrangement can be used in conjunction with octave or one-third octave filter sets as well as the weighting networks built into the sound level meter. Comparisons between individually logged data channels and scanned data using the equipment shown in Figure C.3 show very good agreement above the 100 Hz one-third octave band.

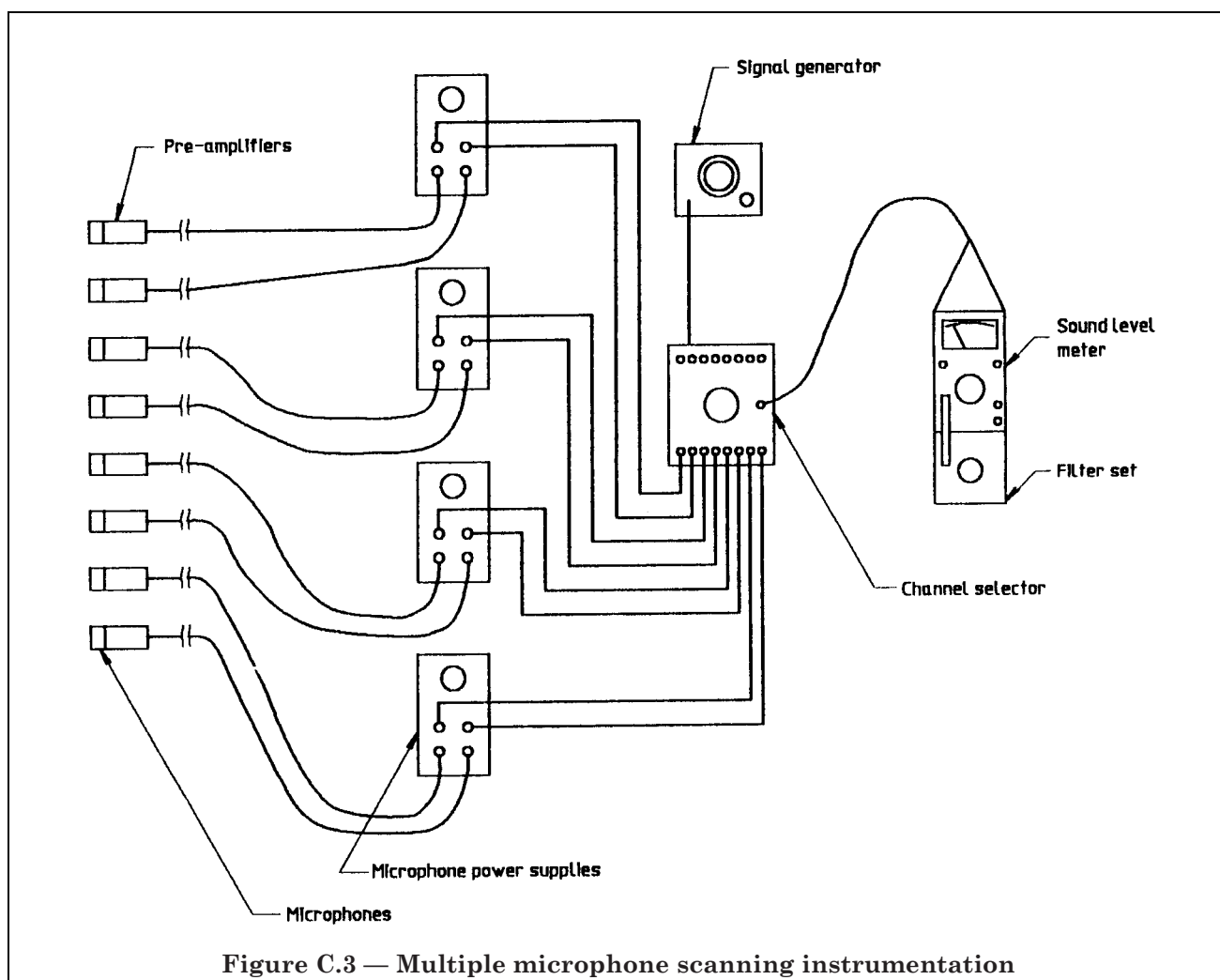

Figure C.3 — Multiple microphone scanning instrumentation

C.4.5 Calculation of sound power level

The sound power level can be calculated from equation 3 in ISO 3744:1981.

Assuming a measurement radius of 1 m, the correction for free-field conditions (i.e. fully anechoic) is + 11 dB. The correction for a free field over a reflecting plane, as required by this part of ISO 4412, is + 8 dB. It is recommended that, whenever possible, the sound field be calibrated by placing a standard sound source at the position normally occupied by the motor, with motor load shaft and fluid lines in position. Significant variation from the + 8 dB correction may indicate excessive distortion of the sound field by motor ancillaries, inadequate reflecting plane, or some other problem.

For measurement radii greater than 1 m, the appropriate correction factors should be calculated according to the area of the measurement surface used.

C.4.6 Frequency analysis

The response of the human ear is very dependent on the frequency as well as the amplitude of sound. Microphones complying with the requirements of IEC 561 have a linear response to sound pressure from 10 Hz to 20 kHz. In order to model the physiological effect of sound, a frequency-weighting filter is built into sound level meters. This weighting is termed the "A scale" and overall sound levels are measured in terms of decibels (A). This single figure rating is the common basis for rating sound levels. If more information is required about the spectral content of the sound, octave or one-third octave filters are used to give low resolution frequency analysis.

For diagnostic and development work, a higher resolution frequency analysis may be required to help identify particular noise sources or pathways. The two basic forms of narrow-band frequency analysers are analog filters or digital Fourier analysers. The analog filters are rapidly becoming obsolete with the availability of hard-wired dedicated digital Fourier analysers, made possible by advances in microelectronics. An alternative to the dedicated digital analyser is a minicomputer which, although slower in operation, retains the high degree of flexibility of its associated software. A detailed description of this equipment is outside the scope of this part of ISO 4412.

C.4.7 Background noise

The airborne noise from the motor under test has to be the dominant component of the noise reaching the microphones. Other noise sources, from both inside and outside the chamber, cannot be completely eliminated but the effect of the unwanted additional noise becomes insignificant if this background level is more than 10 dB below the measured total noise. If the difference is less than 10 dB but more than 6 dB, corrections can be made to the measured level to take this into account.

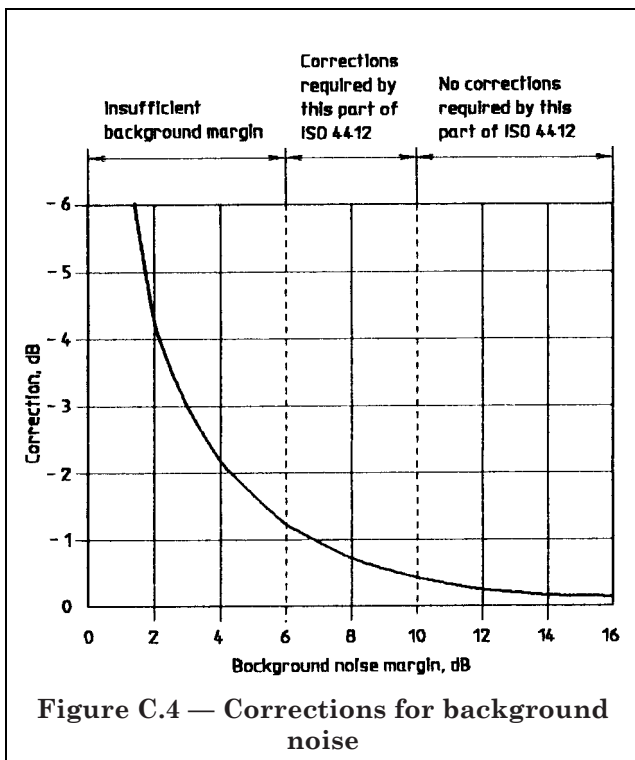

In the case where the background noise is 6 dB or less below the measured total noise, the requirements of this part of ISO 4412 are not satisfied, although an estimate of the motor noise can still be made. Figure C.4 shows the relationship between the correction and the background noise margin.

The background noise level may be determined by running the motor under test conditions and measuring the noise level. An acoustic cover is then placed over the motor and the noise measurements repeated. The performance of the cover has to be sufficient to attenuate substantially the noise emitted by the motor itself, so that the measured noise with the cover in place is dominated by background noise sources. The cover should mask only the motor itself, and not cover the cladding over the input shaft or fluid lines, as these might be contributing to the unwanted background noise. It is normally difficult to devise a motor cover that shrouds the entire motor when mounted according to this part of ISO 4412 without also partially covering the motor mount. This is acceptable only if the mount is known to produce a negligible contribution to overall sound level (see C.5.2).

Adequate backgrounds are particularly difficult to achieve in the lower frequency ranges due to the reduced performance of acoustic cladding. Difficulty may also be experienced when testing a small or quiet motor when the emitted noise is low. Cladding techniques that can help to overcome these problems are described in C.5.5.

C.5 Installation and test layout

C.5.1 Test layout

The following arrangement has been used successfully for motor noise measurements in accordance with this part of ISO 4412.

Figure C.5 shows the basic arrangement in which the motor is placed at the centre of the reflecting plane. Figure C.6 shows details of the mounting and drive arrangements. It is important that the motor, the load shaft, the fluid lines and the load, etc. are all structurally isolated from the floor to prevent vibrations exciting the whole building. The motor and shaft support bearing are therefore mounted on massive concrete blocks and flexible mountings placed between the concrete blocks and the chamber floor. The mass of the concrete blocks allows a considerable degree of isolation to be incorporated while preventing excessive movement of the motor mounting or shaft bearing due to torque reaction.

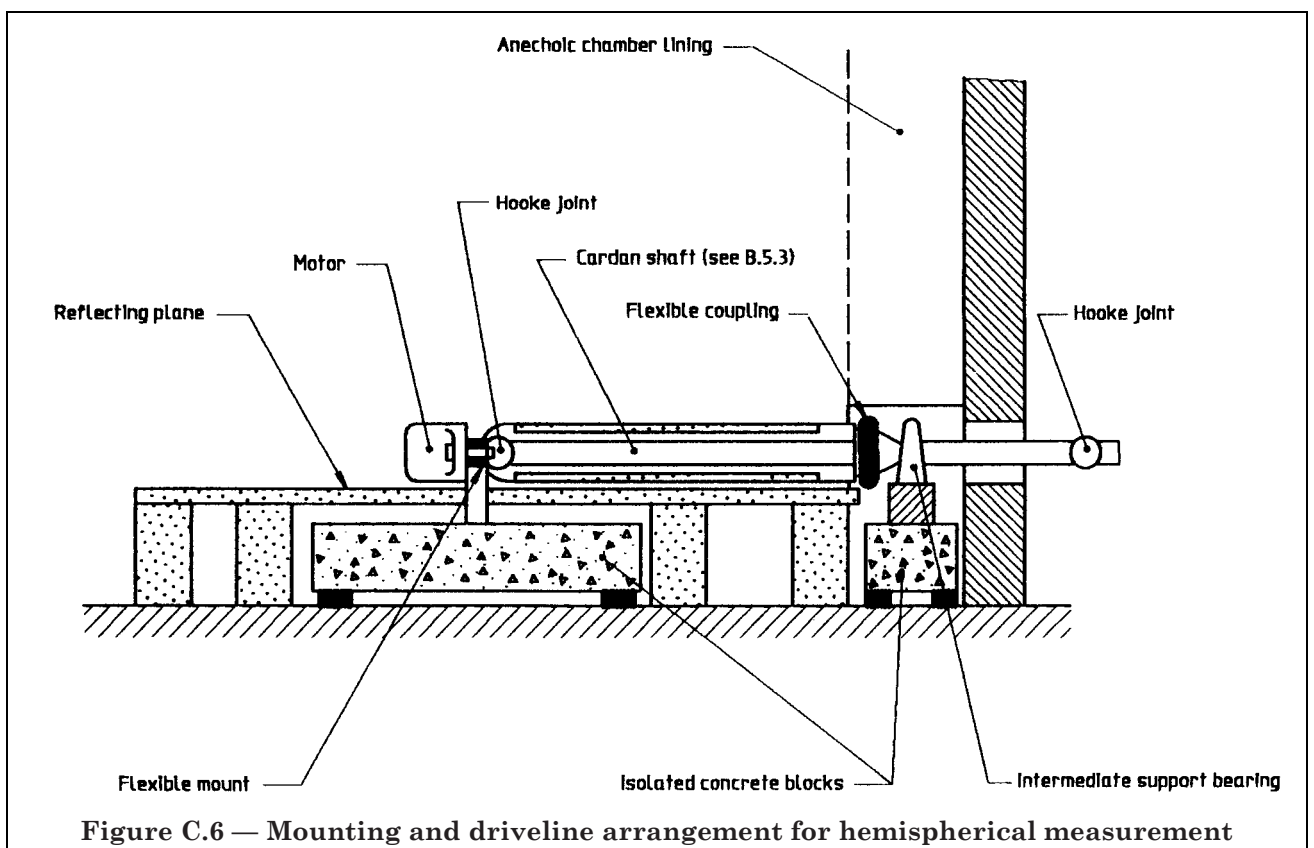
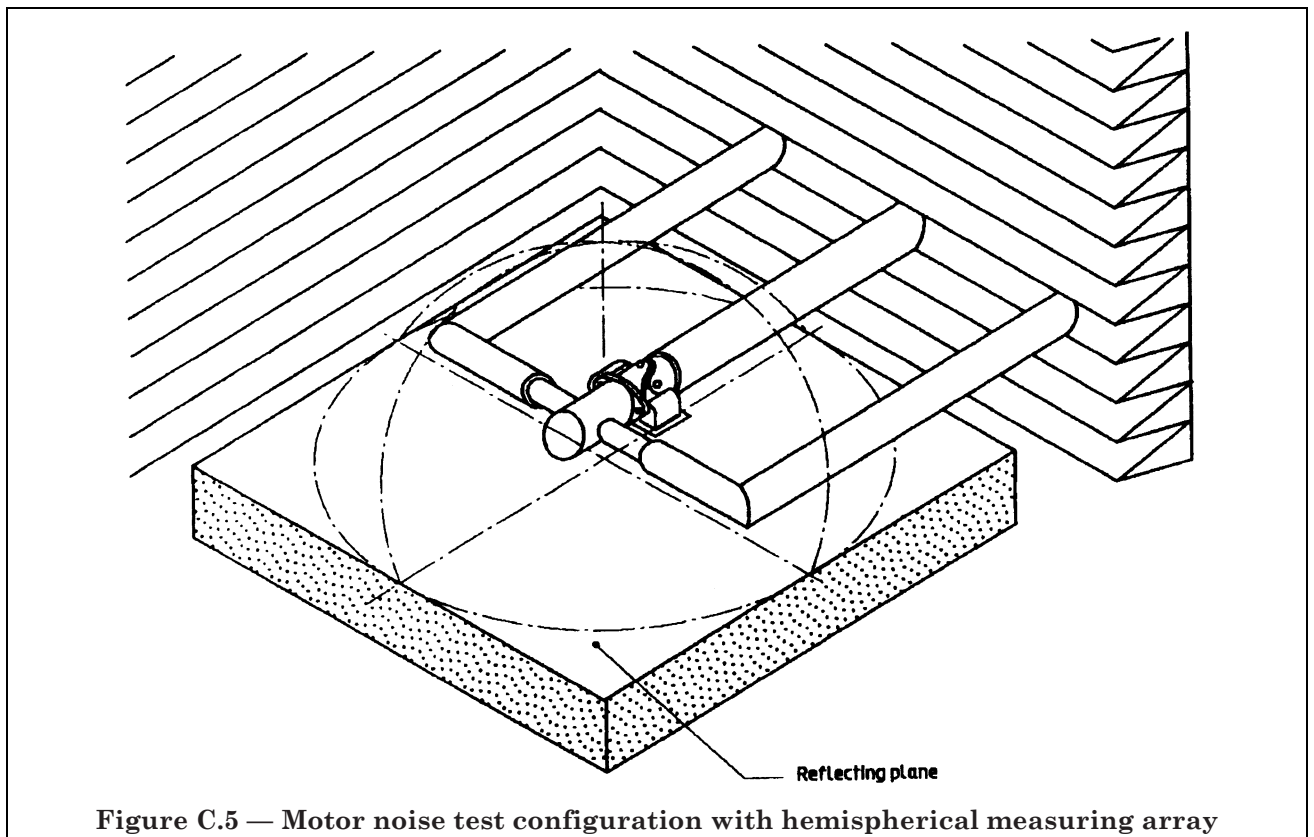

A reflecting plane of sealed concrete slabs is built up above the floor to a level just below the motor. This sealing may be achieved by applying a suitable oil-proofing compound to the concrete. It has been found that, provided the slabs are carefully aligned and levelled, no special treatment of the joints between adjacent slabs is required.

C.5.2 Motor mounting

This part of ISO 4412 requires that the motor mounting be so constructed that it creates minimum disturbance to the sound field at the shaft end of the motor. This can be achieved if the mounting flange does not extend beyond the motor flange. The test method also requires the mount to be acoustically shielded to prevent it emitting a significant level of sound. These two requirements can cause problems, as any acoustic cladding will add to the bulk of the mount. A solution may be to use a close fitting, but free-standing, glass fibre moulding over the mount. The mount would have to be profiled to facilitate sealing with this cover. An alternative is available, however. The test method specifically allows the use of flexible isolators to be used at the interface between the motor and its mount although it recognizes that this does not represent current commercial practice. This arrangement offers several advantages.

First, the transmission of structure-borne noise into the mount is attenuated. This reduces the airborne noise radiated by the mount and thereby eliminates the need for acoustic cladding. Secondly, the mount can be constructed to allow the shaft face of the motor to contribute to the overall measured sound level. Most forms of commercial mount only partially cover this face, so the sound radiation characteristics of this area should logically be included in the measurement, although this part of ISO 4412 is not specific in this respect. Thirdly, the structural impedance mismatch between the motor and its mount attenuates interactive dynamic responses. This ensures the motor casing noise is unaffected by the mount's characteristics, resulting in a higher degree of system independence.

The mounting devised is shown in Figure C.7, and consists of two vertical hollow steel columns so spaced as to coincide with the motor mounting bolts. The motor is carried on isolation bushes at the top of each pillar. Versions have been designed for the two-bolt and four-bolt flange mounting configurations which are the subject of ISO 3019-2. The vertical columns create minimum disturbance to the sound field.

It should be borne in mind that high-torque motors may require mountings that are more substantial.

The use of adapter flanges to enable motors of different sizes to be mounted on the same mount is not recommended. Development work has shown that these can significantly affect the measured sound level.

C.5.3 Drive shaft

Drive is carried to the load via a cardan shaft, having a Hooke joint at the motor end and a polymeric ring ("doughnut") coupling at the other end. The polymeric coupling provides structural isolation between the load and the drive shaft, while the Hooke joint, being small in diameter, minimizes interference with the sound field. A centring bush is required at the polymeric coupling end to prevent shaft whirl at high speed.

Ideally, a single shaft should be used between the load and motor. If, however, chamber dimensions and required running speed prevent this, an intermediate bearing is required. This bearing should be placed outside the measurement hemisphere. A suitable layout uses a self-aligning rolling contact bearing mounted on a concrete block just inside the anechoic chamber, within the "wedge depth". A second shaft passes through this bearing and connects with the load via a Hooke joint outside the chamber wall. Figure C.6 shows the arrangement.

The side and end loadings imposed by this form of drive can be very low if the shafts are well balanced. Careful shaft alignment is not required.

High-torque motors may require the use of a more substantial type of drive shaft system.

C.5.4 Hydraulic lines

Fluid inlet, outlet and, when applicable, leakage return lines need to be routed to the motor. It is possible for these lines to approach the motor from under the reflecting plane, but this causes problems of adaptability when testing different configurations of motors. It is operationally much simpler to run the lines above the reflecting plane. This allows direct access and eliminates the need for tight bends close to the motor. The noise radiation from these lines has to be prevented from reaching the microphones by acoustic cladding. It is essential to use hose for these fluid lines as it has been found that motor structural vibrations cause rigid lines to emit very high airborne noise levels, thus making them more difficult to clad effectively. Avoid curved hose runs as these are also awkward to cover. An efficient solution is to use short stub hoses incorporating 90° swept bends and fittings as shown in Figure C.8. This arrangement can be simply covered with straight acoustic ducts. The rigid fittings between the motor and the hose should be minimized.

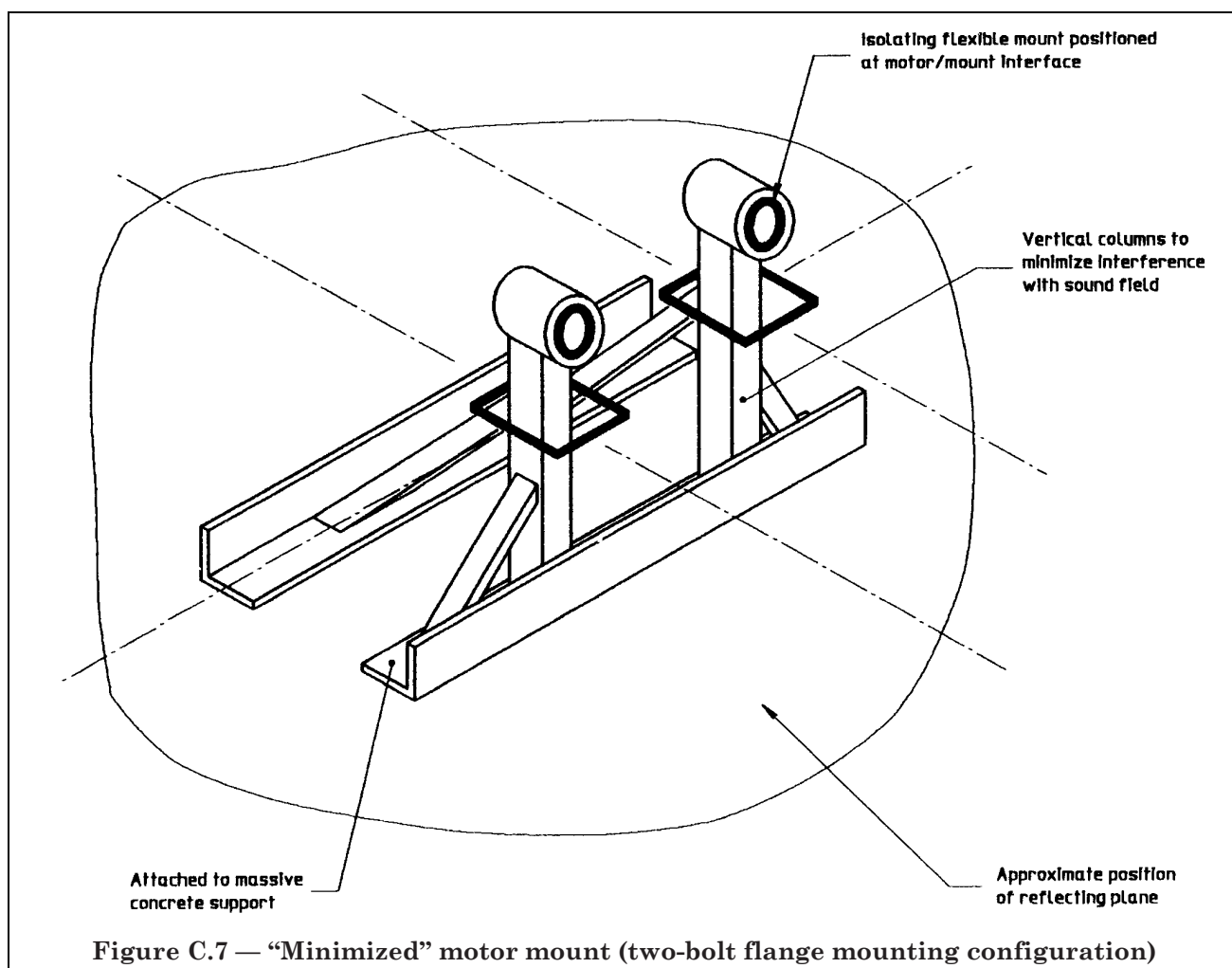

Figure C.7 — “Minimized” motor mount (two-bolt flange mounting configuration)

The outlet fitting incorporates a pressure tapping which should be connected to a pressure sensor mounted at the same height as the tapping. Care should be taken to ensure that there are no air leaks between the fitting and sensor. Also the line should be purged of air to prevent air locks that create false readings of the relatively low pressures.

C.5.5 Acoustic cladding

All the motor ancillaries, such as output shaft and fluid lines, have to be covered in acoustic cladding to prevent their noise radiation being included in the motor’s measured noise output. The function of the cladding is to act as a sound transmission impedance mismatch. This may be achieved most effectively by use of a dense impervious layer separated from the radiating surface by an air gap. Sound-absorbent material is also required in this air gap to prevent the build-up of high levels of reflected sound. The absorbent material may be used to support the barrier layer on the source, but the amount of material used should be minimized to prevent structural transmission.

Fluid lines should be enclosed in a massive, well-damped duct, such as a rigid PVC water pipe. Rings of polyurethane foam can be placed at 1 m intervals and at bends to support the fluid line away from the duct wall and to prevent the build-up of reverberant sound. If the fluid lines are hose, they can be strapped to lengths of light-gauge steel angle section to prevent sagging.

The ends of the duct should be sealed with rings of foam. The outside dimensions of the duct should be kept as small as possible to minimize interference with the sound field around the motor. Normally, an air gap of 20 mm to 25 mm surrounded by a duct of approximately 6 mm wall thickness will sufficiently reduce sound.

Little deterioration in acoustic performance has been found if the PVC duct is split lengthways to facilitate assembly, providing the gaps are closed with heavy tape. Figure C.8 illustrates the cladding technique.

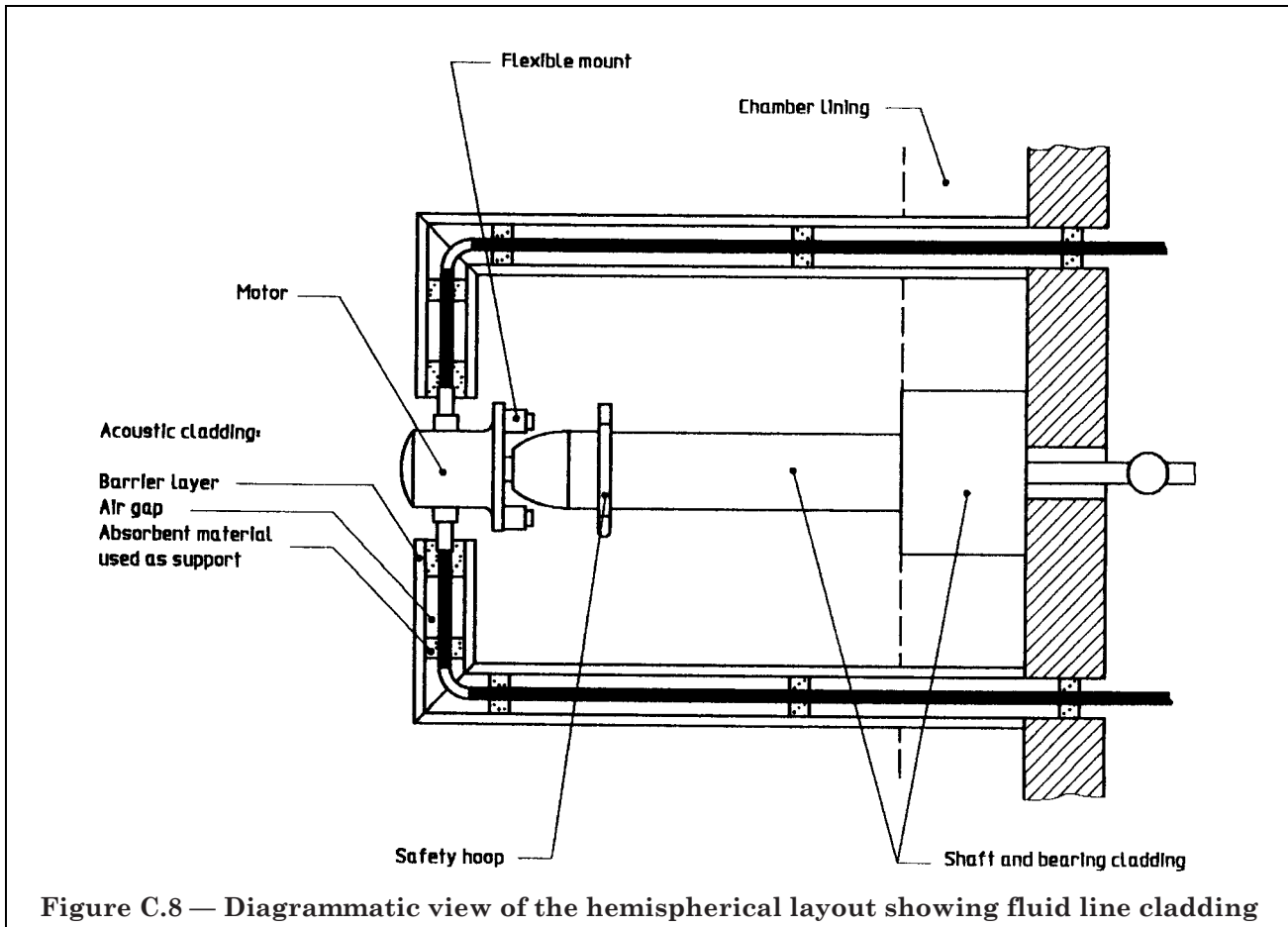

The PVC duct may, if required, be solidly mounted to the reflecting plane or chamber wall since it provides an effective isolated support for the fluid line inside.

The load shaft should be enclosed in an acoustically lined duct. PVC water pipe is again a suitable material, split lengthways for ease of assembly and sealed with heavy tape. In order to minimize the external diameter of the duct, it is recommended that it be lined along the length of the cardan shaft only, and not over the couplings at either end.

It may prove necessary to cover the Hooke joint at the motor end, in which case a light unlined cover of glass reinforced plastic or similar material is recommended, shaped to give minimum masking at the shaft face of the motor.

The shaft cover should be carefully aligned and rigidly mounted to the reflecting plane to ensure that it cannot foul the rotating shaft.

The intermediate bearing, if used, may be covered with a free-standing acoustically lined box, constructed of glass reinforced plastic or 19 mm plywood. In the installation illustrated, this box is mounted and sealed between the chamber wall and the reflecting plane (Figure C.6) and forms the support for one end of the shaft cover. The bearing and shaft covers thus form an acoustic duct to attenuate airborne noise passing through from the load unit.

C.5.6 Hydraulic test circuit

An open- or closed-loop circuit should be employed, the outlet pressure being regulated and in line with the manufacturer's recommendations. An example of a suitable test circuit is shown in Figure C.9. An appropriate load should be applied to the motor using an absorption dynamometer. If a hydraulic pump is used as the load, care should be taken to ensure that a torsional resonance is not created by interaction between the pump's and the motor's torque ripple. Contamination protection and temperature control are also required. Oil temperature and inlet pressure should be measured at the motor inlet fitting with a calibrated sensor. The outlet pressure should be measured at the motor outlet fitting. The sensor should be mounted in accordance with 7.4.4. A shut-off valve is not recommended as a snubber because a non-return action can occur at small openings causing the gauge to indicate peak rather than mean line pressure.

Special care should be taken to eliminate resonant interactions or beating between the pump and motor fluid-borne noise in both the inlet and outlet lines. Accumulators or silencing devices may be necessary in these lines which should also incorporate at least a 1 m length of flexible hose close to each motor port. Beating between the pump and motor fluid-borne noise should be checked for by repeating one microphone position sound pressure level three times and looking for repeatability of the result.

C.5.7 Running-in of test motors

The noise characteristics of some motors have been found to change markedly in the first few hours of running. Therefore new motors should be run-in before testing.

C.5.8 Safety precautions

The presence of a long drive shaft in the anechoic chamber necessitates certain precautions. The acoustic cladding of the shaft should cover all rotating parts and be of sufficient strength to act as a safety guard. It is also recommended that a strong steel hoop be placed over the shaft cladding near the motor end and firmly attached to the chamber floor to guard against coupling or motor-mounting failure.

C.6 Results

C.6.1 Test ranges

It is often useful to obtain a standard set of data for each motor which allows assessment of the noise output throughout the operating range, as well as taking measurements at specific operating conditions relating to a particular application. This standard set of data aids both with comparison between motors and in studying the effect of modifications or wear. The validity of the measurements in terms of spatial averaging and background levels is also checked. It has been found convenient to carry out measurements as follows.

- a) A-weighted sound power, in decibels (A), versus motor shaft rotational speed for small increments over the motor's permissible speed range at the maximum continuous rated pressure.
- b) Directivity measurements, in decibels (A), taken for at least five commonly used speeds covering the operating range.
- c) The motor is then covered with an acoustic enclosure and test a) repeated to establish background levels.
- d) One-third octave or octave measurements are taken, with the motor still covered, at the speeds used in b).
- e) One-third octave or octave measurements are repeated with the motor exposed.
- f) Finally, the effect of pressure may be obtained by measuring A-weighted levels, in decibels (A), for at least five pressures evenly spaced throughout the rated operating range. For example: 25 MPa, 16 MPa, 10 MPa, 6,3 MPa and 4 MPa (250 bar, 160 bar, 100 bar, 63 bar and 40 bar) at each standard rotational speed given in b).

This test sequence minimizes the effort required in changing cladding and instrumentation, whilst highlighting measurement problems at an early stage.

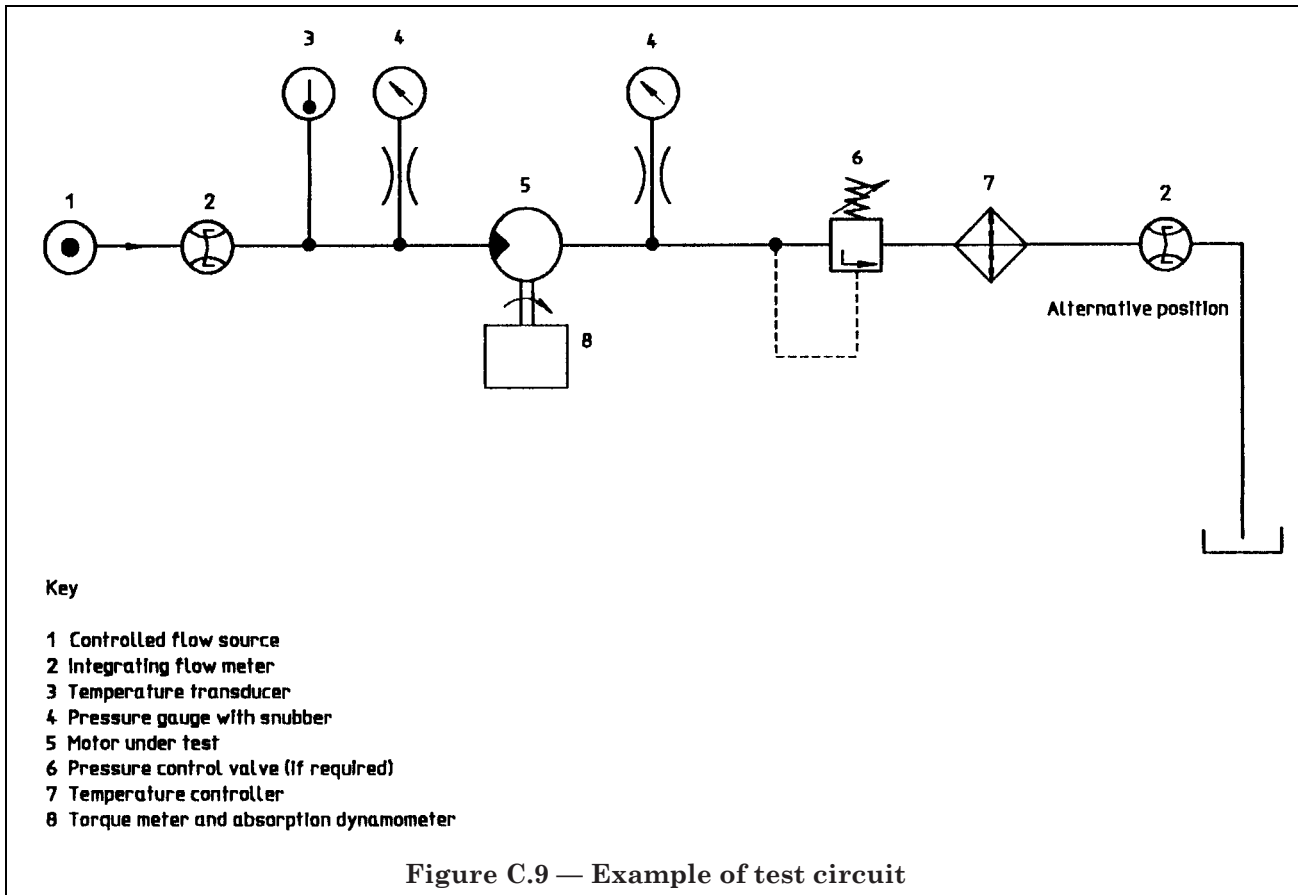

Figure C.9 — Example of test circuit

C.6.2 Interpretation of check data

If a strong resonance exists in the motor mounting or shaft, it can show up as a sharp peak in the run speed versus A-weighted levels, in decibels (A). The background noise checks of overall A-weighted levels, in decibels (A), and one-third octave plots will show up weaknesses in the structural isolation or acoustic cladding of the ancillaries in the chamber. The directivity measurements will indicate whether a sufficient number of microphone measurement points is being used.

This test sequence does not give the full checks called for in this part of ISO 4412. These represent an unrealistic work load for every set of measurements. After the initial commissioning of the facility, and once a degree of confidence in the measurements has been built up, periodic checks have been found to be adequate.

C.6.3 Oil temperature

Only the temperature tolerance ($\pm 2^\circ\text{C}$) is specified in this part of ISO 4412. Obviously, it is up to the individual manufacturer or user to specify the test temperature. The normal test temperature for many motors is 50°C .

C.6.4 Presentation of results

This part of ISO 4412 permits noise levels to be presented in the form of either sound pressure or sound power, in decibels or in picowatts respectively. In practice, most sales literature specifies noise levels in terms of sound pressure measured at 1 m radius in a free field over a single reflecting plane, which gives a value numerically 8 dB less than the sound power value. The argument is that the sound pressure value relates more directly to the sound field encountered in practice than the more abstract concept of sound power.

Annex D (informative) Bibliography

- [1] ISO 2204:1979, *Acoustics — Guide to International Standards on the measurement of airborne acoustical noise and evaluation of its effects on human beings.*
- [2] ISO 3019-2:1986, *Hydraulic fluid power — Positive displacement pumps and motors — Dimensions and identification code for mounting flanges and shaft ends — Part 2: Two- and four-hole flanges and shaft ends — Metric series.*

List of references

See national foreword.

**BS 5944-2:
1992
ISO 4412-2:
1991**

BSI — British Standards Institution

BSI is the independent national body responsible for preparing British Standards. It presents the UK view on standards in Europe and at the international level. It is incorporated by Royal Charter.

Revisions

British Standards are updated by amendment or revision. Users of British Standards should make sure that they possess the latest amendments or editions.

It is the constant aim of BSI to improve the quality of our products and services. We would be grateful if anyone finding an inaccuracy or ambiguity while using this British Standard would inform the Secretary of the technical committee responsible, the identity of which can be found on the inside front cover. Tel: 020 8996 9000. Fax: 020 8996 7400.

BSI offers members an individual updating service called PLUS which ensures that subscribers automatically receive the latest editions of standards.

Buying standards

Orders for all BSI, international and foreign standards publications should be addressed to Customer Services. Tel: 020 8996 9001. Fax: 020 8996 7001.

In response to orders for international standards, it is BSI policy to supply the BSI implementation of those that have been published as British Standards, unless otherwise requested.

Information on standards

BSI provides a wide range of information on national, European and international standards through its Library and its Technical Help to Exporters Service. Various BSI electronic information services are also available which give details on all its products and services. Contact the Information Centre. Tel: 020 8996 7111. Fax: 020 8996 7048.

Subscribing members of BSI are kept up to date with standards developments and receive substantial discounts on the purchase price of standards. For details of these and other benefits contact Membership Administration. Tel: 020 8996 7002. Fax: 020 8996 7001.

Copyright

Copyright subsists in all BSI publications. BSI also holds the copyright, in the UK, of the publications of the international standardization bodies. Except as permitted under the Copyright, Designs and Patents Act 1988 no extract may be reproduced, stored in a retrieval system or transmitted in any form or by any means – electronic, photocopying, recording or otherwise – without prior written permission from BSI.

This does not preclude the free use, in the course of implementing the standard, of necessary details such as symbols, and size, type or grade designations. If these details are to be used for any other purpose than implementation then the prior written permission of BSI must be obtained.

If permission is granted, the terms may include royalty payments or a licensing agreement. Details and advice can be obtained from the Copyright Manager. Tel: 020 8996 7070.

BSI
389 Chiswick High Road
London
W4 4AL