



Precast concrete pipes, fittings and ancillary products —

Part 114: Specification for porous pipes

Committees responsible for this British Standard

The preparation of this British Standard was entrusted by the Cement, Gypsum, Aggregates and Quarry Products Standards Policy Committee (CAB/-) to Technical Committee CAB/12, upon which the following bodies were represented:

Association of Consulting Engineers
 Association of Metropolitan Authorities
 British Cement Association
 British Precast Concrete Federation Ltd.
 Concrete Pipe Association
 Concrete Society
 County Surveyors' Society
 Department of Transport
 Federation of Civil Engineering Contractors
 Institution of Civil Engineers
 Institution of Highways and Transportation
 Institution of Water and Environmental Management
 Ministry of Agriculture, Fisheries and Food
 Pipe Jacking Association
 Sand and Gravel Association Limited
 Water Services Association of England and Wales

The following body was also represented in the drafting of the standard, through subcommittees and panels:

Department of Transport

This British Standard, having been prepared under the direction of the Cement, Gypsum, Aggregates and Quarry Products Standards Policy Committee, was published under the authority of the Standards Board and comes into effect on 15 November 1992

© BSI 02-1999

The following BSI references relate to the work on this standard:
 Committee reference CAB/12
 Draft for comment 90/11577 DC

ISBN 0 580 19993 2

Amendments issued since publication

Amd. No.	Date	Comments

Contents

	Page
Committees responsible	Inside front cover
Foreword	ii
<hr/>	
Section 1. General	
1 Scope	1
2 Definitions	1
<hr/>	
Section 2. Materials	
3 Cement	2
4 Aggregates	2
5 Other concrete materials	2
6 Concrete	2
<hr/>	
Section 3. Dimensions and tolerances	
7 Nominal size (DN)	3
8 Effective length of pipes	3
9 Diameters	3
10 Variation in the thickness of wall	3
11 Deviation from straightness	3
12 Joints	3
13 Non-porous inverts	3
<hr/>	
Section 4. Tests	
14 General	4
15 Test requirements	4
<hr/>	
Section 5. Inspection procedures and marking	
16 Type of inspection and batch size	5
17 Inspection procedures	6
18 Marking	6
<hr/>	
Appendix A Information to be supplied in an enquiry and order	8
Appendix B Method of assessment of deviation from straightness	8
Appendix C Method of carrying out infiltration test	9
Appendix D Crushing load tests for pipes	9
Appendix E Facilities for purchasers	11
<hr/>	
Figure 1 — Typical joints	1
Figure 2 — Effective length of units	1
Figure 3 — Non-porous invert	3
Figure 4 — Gauge for assessing deviation from straightness	8
Figure 5 — An arrangement for a porous pipe testing apparatus	9
Figure 6 — Testing arrangement for the crushing test	11
<hr/>	
Table 1 — Nominal sizes and tolerances	3
Table 2 — Infiltration rates and crushing loads	4
Table 3 — Summary of test requirements and inspection procedures	4
Table 4 — Maximum number of individual defectives in last 10 batches permitted for switching to reduced inspection (crushing load test)	5
Table 5 — Inspection plans for crushing load tests	6
Publication(s) referred to	Inside back cover

Foreword

This Part of BS 5911 has been prepared under the direction of the Cement, Gypsum, Aggregates and Quarry Products Standards Policy Committee. It supersedes BS 1194:1969 which is withdrawn.

In carrying out the revision the opportunity has been taken to integrate the new standard with the BS 5911 series and to align the contents wherever appropriate with BS 5911-100.

Compared with BS 1194, which has remained untouched since its publication in 1969, the revision is fully metricated and incorporates an inspection system based on BS 6001-1:1991 for controlling production batches.

Product certification. Users of this British Standard are advised to consider the desirability of third party certification of product conformity with this British Standard based on testing and continuing surveillance, which may be coupled with assessment of a supplier's quality systems against the appropriate Part of BS 5750.

Enquiries as to the availability of third party certification schemes will be forwarded by BSI to the Association of Certification Bodies. If a third party certification scheme does not already exist, users should consider approaching an appropriate body from the list of Association members.

A British Standard does not purport to include all the necessary provisions of a contract. Users of British Standards are responsible for their correct application.

Compliance with a British Standard does not of itself confer immunity from legal obligations.

Summary of pages

This document comprises a front cover, an inside front cover, pages i and ii, pages 1 to 12, an inside back cover and a back cover.

This standard has been updated (see copyright date) and may have had amendments incorporated. This will be indicated in the amendment table on the inside front cover.

Section 1. General

1 Scope

This Part of BS 5911 specifies requirements for unreinforced porous concrete pipes which are intended to admit water through the pipe wall throughout their full length and full circumference or, in the case of pipes with non-porous inverts, throughout part of their circumference. Porosity of the joint is not a requirement.

The specification covers constituent materials, dimensional requirements, performance requirements, appropriate test methods and inspection procedures.

Combinations of special cements have not been included in this standard in the absence of experience with them in this context.

NOTE The titles of the publications referred to in this standard are listed on the inside back cover.

2 Definitions

For the purposes of this Part of BS 5911 the following definitions apply.

2.1

porous pipe

a hollow cylinder manufactured from unreinforced porous concrete, of uniform internal diameter and cross section throughout its length, except at the joint profile

NOTE When "pipe" is used alone in this standard this indicates a porous pipe.

2.2

barrel

that portion of a pipe throughout which the internal diameter and cross section remain substantially uniform

2.3

rebated joint

a joint made within the wall thickness of a pipe, including ogee joints

NOTE See Figure 1.

2.4

nominal size (DN)

a numerical designation of the bore of a pipe, which is a convenient round number approximately equal to the internal diameter in millimetres

2.5

manufacturing diameter

a diameter of a pipe that a manufacturer seeks to achieve

2.6

actual internal diameter

an internal diameter found by measurement

2.7

effective length

the length of a pipe measured as shown in Figure 2

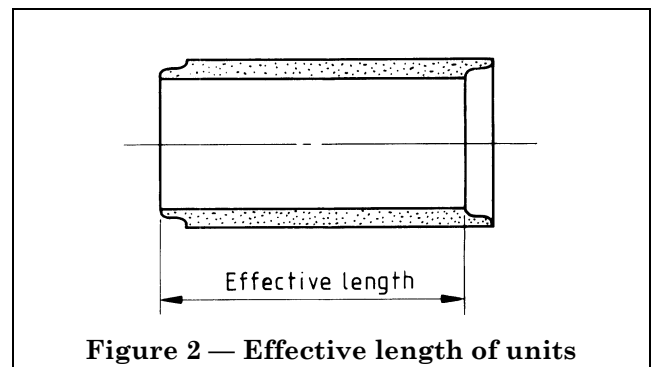

2.8

batch

the number of pipes of a particular specification produced under uniform conditions during a given production period by one particular process

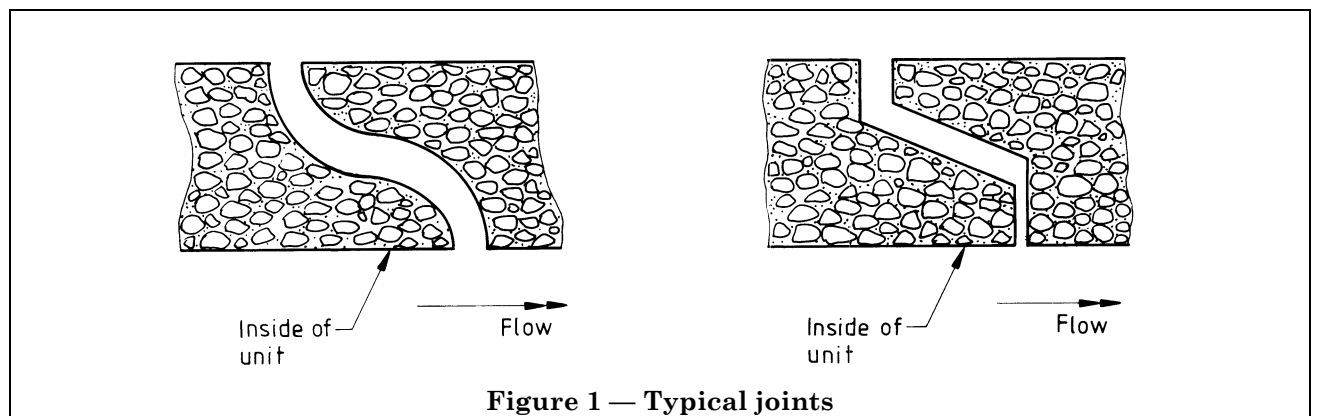

Section 2. Materials

3 Cement

The cement shall be factory-produced by the cement manufacturer and comply with one of the following standards as appropriate:

Type of cement	Standard to be complied with
ordinary and rapid-hardening Portland	BS 12
Portland-blastfurnace	BS 146
sulfate-resisting Portland	BS 4027

4 Aggregates

4.1 General

Aggregates shall consist of either:

- materials complying with BS 882:1983 except that the manufacturer may modify the grading requirements of clause 5 of that standard (see clause 0 of BS 882:1983); or
- lightweight aggregate complying with BS 3797.

4.2 Testing

4.2.1 Mechanical properties

The limiting values on the mechanical properties of coarse aggregates shall be either a minimum 10 % fines value of 100 kN or a maximum aggregate impact value of 30 %. Aggregates complying with BS 3797-2 shall have values of 10 % fines, aggregate impact and chloride ion content which are consistent with the relevant provisions of BS 882.

4.2.2 Nominal maximum size

The nominal maximum size of aggregate shall not exceed the least of the following:

- 20 mm;
- one quarter of the wall thickness.

5 Other concrete materials

5.1 Water

Water shall be clean and free from harmful matter in such quantities as would affect the properties of the concrete in either the plastic or the hardened state (see Appendix A of BS 3148:1980).

NOTE As a general rule, potable water, whether treated for distribution through the public supply or untreated, is suitable for marking concrete.

5.2 Admixtures

Admixtures shall comply with BS 5075.

NOTE Admixtures, when used (see Appendix A), should not impair the durability of the concrete, nor combine with the ingredients to form harmful compounds.

The chloride ion content of admixtures shall not exceed 2 % by mass of the admixture or 0.03 % by mass of the cement, when used in any concrete made with cement complying with BS 4027.

The manufacturer shall make available details of:

- the relevant production records;
- the admixture(s) used;
- the dosage rate of each admixture;
- the effect of under-dosing and over-dosing.

6 Concrete

6.1 Work in cold weather

Concrete, when placed, shall have a temperature of at least 5 °C, which shall be maintained until the concrete is hardened.

It is permissible to heat aggregates and water before mixing to a temperature not exceeding 60 °C.

Other materials and moulds, if at a temperature below 0 °C, shall not be used.

Section 3. Dimensions and tolerances

7 Nominal size (DN)

The nominal sizes (see 2.4) of pipes shall be those given in Table 1.

8 Effective length of pipes

The effective length of pipes, see (2.7), shall be in the range 0.45 m to 1.25 m inclusive.

Information shall be available on the effective lengths of pipes in a given nominal size named in an enquiry or order (see Appendix A).

9 Diameters

9.1 Internal manufacturing diameter and actual diameter

Information shall be available at the enquiry stage on the internal manufacturing diameters (see 2.5) that can be supplied (see Appendix A).

The internal manufacturing diameter shall not be outside the limits given in column 2 of Table 1.

The actual internal diameter (see 2.6) shall not deviate from the manufacturing diameter by an amount greater than that given in column 3 of Table 1.

9.2 External manufacturing diameter

The external manufacturing diameter of the barrel of the pipe (see 2.2) shall be declared if required. (See Appendix A.)

10 Variation in the thickness of wall

The radial thickness of the wall of a pipe shall not vary by more than the amount stated in column 4 of Table 1.

11 Deviation from straightness

When assessed as described in Appendix B, the pipe shall satisfy the criteria for straightness.

12 Joints

The axial length of each joint of a pipe shall be not less than 15 mm or $(0.03 \text{ DN} + 7)$ mm, where DN is the nominal size of the pipe, whichever is the greater. For example, for a section of DN 600, the axial length shall be not less than $(0.03 \times 600 + 7)$ mm = 25 mm. Other joint dimensions shall conform to the manufacturer's stated dimensions and tolerances.

NOTE For typical joints see Figure 1.

13 Non-porous inverts

When specified (see Appendix A) a non-porous invert shall extend for the full length of the pipe and to a height up the pipe equal to not less than one-third of the internal diameter (D) measured from the invert of the pipe as intended to be laid (see Figure 3).

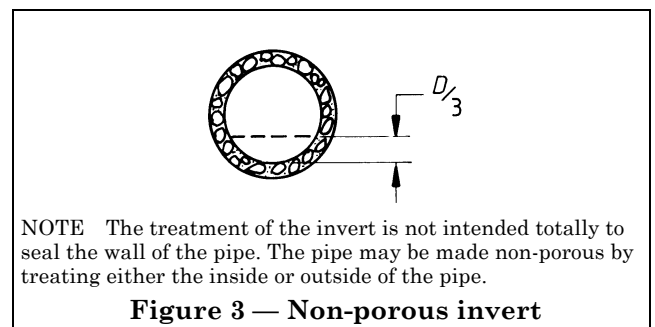

Table 1 — Nominal sizes and tolerances

1	2		3	4
Nominal size of pipes	Permissible limits of internal manufacturing diameter (see clause 9)		Permissible deviation of actual internal diameter from manufacturing diameter (see clause 9)	Variation of wall thickness (see clause 10)
	Maximum diameter	Minimum diameter		
DN	mm	mm	mm (\pm)	mm
100	105	100	5	6
150	155	150	5	6
225	230	225	5	6
300	305	300	5	6
375	385	365	6	6
450	460	440	6	6
525	535	515	6	6
600	610	590	6	6
750	770	730	6	6
900	920	880	6	6

Section 4. Tests

14 General

14.1 Routine and type testing

14.1.1 Pipes shall comply with the appropriate routine and type test requirements given in this section and summarized in Table 3 and shall be inspected using the procedures specified in section 5.

NOTE Inspection procedures are not given in this Part for isolated batches of units subject to the hydrostatic or works proof load crushing test.

14.1.2 Type tests shall be carried out to prove the design of a pipe. They shall be undertaken wherever there is a change in design, type of material or method of manufacture.

14.1.3 Records of all tests and inspection procedures shall be kept by the manufacturer.

14.2 Acceptance of pipes

Pipes shall be considered ready for acceptance only after the design has been proven by type tests and the batch of which the pipes form part has been routinely tested and shown to comply with clause 16.

All pipes within any batch shall be cured and matured under similar conditions. They shall not be despatched until they are at least 10 days old.

15 Test requirements

15.1 Crushing load test

When tested in accordance with Appendix D, a pipe shall support, for 1 min, the load specified in Table 2 without any sign of failure.

Table 3 — Summary of test requirements and inspection procedures

Unit	Nominal size and category	Test	Compliance requirements given in clause	Test method given in	Required as type test (see 14.1.1)	Required as routine test	Inspection procedures given in clause
Pipe	All	Infiltration	15.2	Appendix C	✓	✓	17.2
	All	Crushing load	15.1	Appendix D	✓	✓	17.1
	All	Straightness	11	Appendix B	—	—	See note 1
	All	Joints	12	—	✓	—	See note 1
	All	Dimensions	7, 8, 9, 10	—	✓	—	See note 1

NOTE 1 These tests are to be carried out as and when required.

NOTE 2 Inspection procedures are not given in this Part for isolated batches of units.

NOTE Cube tests for the concrete used in pipes and built-up bends and junctions are not required because the concrete used in the manufacture of these units is generally compacted in quite a different way from the method specified in BS 1881-5.

Table 2 — Infiltration rates and crushing loads

Nominal size	Infiltration rate	Crushing load (minimum)	
		Class 1	Class 2
DN	l/min/m	kN/m	kN/m
100	65	20	—
150	100	20	—
225	150	20	—
300	200	20	—
375	250	20	—
450	250	20	23
525	250	20	25
600	250	20	27
750	250	20	30
900	250	20	30

15.2 Infiltration test

When tested in accordance with Appendix C, porous pipes shall have an average rate of infiltration of not less than the values shown in Table 2, column 2. Any individual result shall be not less than half the stated infiltration rate.

The rate of infiltration for porous pipes with non-porous inverts shall be ascertained before the invert is treated.

Section 5. Inspection procedures and marking

16 Type of inspection and batch size

16.1 Type of inspection

16.1.1 Normal inspection

Normal inspection shall be used when a process has been in operation long enough to be in a state of control.

16.1.2 Tightened inspection

Tightened inspection shall be used:

- a) when inspecting a new product, a redesigned product or a new production line; or
- b) when so directed by the switching rules in 16.2.

16.1.3 Reduced inspection

Reduced inspection shall be substituted for normal inspection only when permitted by the switching rules given in 16.2.4.

16.2 Switching rules

16.2.1 General

Changes from one inspection type to another shall be in accordance with the following switching rules. The rules given in 16.2.2, 16.2.5 and 16.2.6 shall apply in all cases whereas the rules given in 16.2.3 and 16.2.4 shall apply at the discretion of the manufacturer.

16.2.2 Normal to tightened inspection

When using normal inspection, switch to tightened inspection if two in five or less consecutive batches have been rejected.

16.2.3 Tightened to normal inspection

When using tightened inspection, switch to normal inspection only when five consecutive batches have been accepted.

16.2.4 Normal to reduced inspection (infiltration or crushing load test)

16.2.4.1 When using normal inspection, switch to reduced inspection only if:

- a) the last 10 batches given (see Table 4) have been subject to normal inspection and have all been accepted; and
- b) the total number of defectives in samples taken from the last 10 batches is less than or equal to the number given in Table 4. When double sampling is used all samples inspected shall be included, i.e. not the first samples only.

16.2.4.2 Where the sample consists of less than 30 pipes, more batches shall be used provided that the batches used are the most recent ones in sequence, that they have all been on normal inspection, and that none has been rejected.

NOTE A total of less than 30 pipes sampled is not sufficient for switching to reduced inspection.

Table 4 — Maximum number of individual defectives in last 10 batches permitted for switching to reduced inspection (crushing load test)

Number of pipes sampled from last 10 batches	Total number of defectives in last 10 batches on normal inspection
30 to 79	0
80 to 129	2
130 to 199	4
200 to 319	8
320 to 499	14
500 to 799	25
800 to 1 249	42

NOTE The values in the table are consistent with those in Table VIII of BS 6001-1:1991 for a target acceptable quality level (AQL) of 6.5 %.

16.2.5 Reduced to normal inspection (infiltration and crushing load tests)

When using reduced inspection, switch to normal inspection if:

- a) a batch is rejected; or
- b) a batch is accepted where the acceptance number given in column 4 (single sampling) or 6 (double sampling) of Table 5 has been exceeded but the rejection number in column 5 (single sampling) or 7 (double sampling) has not been reached; or
- c) production becomes irregular or delayed.

16.2.6 Tightened inspection to stopping production

When using tightened inspection, stop production if it is not possible to switch to normal inspection (see 16.2.3) after 10 consecutive batches.

Investigate the cause of failure and take any necessary remedial action. Resume production using tightened inspection.

16.3 Size of batch

16.3.1 Crushing

When inspecting pipes, it is permissible to choose any size of batch (see 2.8), provided that the requirements given in 14.2 are complied with.

16.3.2 Infiltration

A batch shall comprise one day's production provided that the requirements given in 14.2 are complied with.

Table 5 — Inspection plans for crushing load tests

1	2	3	4	5	6	7
Inspection type	Batch size	Sample size	Accept	Reject	Accept	Reject
Normal	2 to 50	2 (single)	0	1	—	—
	51 to 500	5 (double)	0	2	1	2
	501 to 3 200	8 (double)	0	3	3	4
	3 201 to 10 000	13 (double)	1	4	4	5
Tightened	2 to 50	3 (single)	0	1	—	—
	51 to 3 200	8 (double)	0	2	1	2
	3 201 to 10 000	13 (double)	0	3	3	4
Reduced	2 to 50	2 (single)	0	1	—	—
	51 to 500	2 (double)	0	2	0	2
	501 to 3 200	3 (double)	0	3	0	4
	3 201 to 10 000	5 (double)	0	4	1	5

NOTE This table is based on tables in BS 6001-1:1991 and is consistent with a target acceptable quality level (AQL) of 6.5 % at Special Inspection Level S3.

17 Inspection procedures

17.1 Inspection procedures for crushing load test

When carrying out the crushing load test, the inspection procedure for each batch shall be as follows.

- Determine the appropriate inspection type (see 16.1).
- Select the batch size (see 16.3).
- Take a random sample of the size given in column 3 of Table 5 for the appropriate inspection type and size of batch.
- Subject the sample to the appropriate crushing load test specified in 15.1.
- Assess the acceptability of the batch, as follows:
 - For batches of 25 or less (single sampling), if the number of defectives is nil (see “Accept” number in column 4 of Table 5), accept the batch. If the number of defectives is one or more (see “Reject” number in column 5 of Table 5), reject the batch.
 - For batches of 26 or more (double sampling), if the number of defectives is equal to or less than the “Accept” number in column 4 of Table 5, accept the batch, with the exception of any defectives. If the number of defectives is equal to or greater than the “Reject” number in column 5 of Table 5, reject the batch.

However, if the number of failures is greater than the “Accept” number in column 4 but less than the “Reject” number in column 5, take a second random sample of the same size as the first one. Then if the cumulative number of defectives for both samples is less than the second “Reject” number (column 7), accept the batch, with the exception of any defectives [see also 16.2.4.1 b)]. If the cumulative number of defectives is equal to or greater than the second “Reject” number in column 7, reject the batch.

- Record the results.

17.2 Inspection procedure for infiltration test

The production from each machine shall be sampled on a daily basis at the following rates:

- up to 200 pipes: 2
- 201 and above: 3

If the batch fails a second sample shall be taken of double the size of the first sample and tested in accordance with 15.2.

If the second sample passes the whole of the batch shall be accepted except those pipes which failed to achieve 50 % of the infiltration rate shown in column 2, Table 2.

Should the second sample fail, the batch shall be rejected.

18 Marking

18.1 Pipe

Each pipe which is made with sulfate-resisting Portland cement shall be clearly marked with blue indelible paint.

Each class 2 pipe (see **15.1**) shall be clearly marked with yellow indelible paint.

18.2 Documentation

The delivery note issued by the manufacturer in respect of all pipes manufactured in accordance with this standard shall clearly state the following information:

- a) the number of this British Standard, i.e. BS 5911-114¹⁾;
- b) the type of cement used in the manufacture of this pipe;
- c) the strength classification, i.e. class 1 or 2;
- d) whether admixtures have been used;
- e) the date of manufacture.

¹⁾ Marking BS 5911-114 on or in relation to a product represents a manufacturer's declaration of conformity, i.e. a claim by or on behalf of the manufacturer that the product meets the requirements of the standard. The accuracy of the claim is therefore solely the responsibility of the person making the claim. Such a declaration is not to be confused with third party certification of conformity, which may also be desirable.

Appendix A Information to be supplied in an enquiry and order

The following particulars cover essential details required by the manufacturer so that an enquiry or order may be fully understood:

- a) quantity, category and nominal sizes of pipes (see clause 7);
- b) if any restriction on effective length is to apply (see clause 8);
- c) crushing test loads of pipes, class 1 or 2 where applicable (see 15.1);
- d) the classification of exposure conditions for sulfate attack, if higher than exposure class 2 (see BS 8110);
- e) if samples of aggregates and/or evidence of satisfactory performance of concrete made with such aggregates are required (see 4.1 and Appendix E);
- f) if any restriction on admixtures is required (see 5.2);
- g) whether details of internal and external diameter are required (see clause 9);
- h) the number and type of tests to be witnessed and if any additional tests are required (see Appendix E);
- i) if the products are to be covered by a third party certification scheme (see Appendix E);
- j) whether non-porous inverts are needed (see clause 13).

Appendix B Method of assessment of deviation from straightness

The deviation from straightness of pipes shall be assessed in the following manner.

- a) Place a rigid straightedge, made into a gauge of the form and dimensions shown in Figure 4, in the bore of the pipe with edge X in contact with the pipe and on a line parallel to the pipe axis. Hold the plane of the gauge in a radial plane.

If both ends of the gauge, when so placed, are in contact with the internal surface of the pipe, the deviation from straightness is excessive.

If this condition occurs at any one of four or more different positions of the gauge, the pipe does not comply with this particular requirement.

- b) If both ends of the gauge, when used as described in a), are not in contact with the internal surface of the pipe, reverse the gauge so that edge Y, placed as in a) is adjacent to the internal surface of the pipe.

If the two studs in edge Y cannot be made to touch the surface of the pipe simultaneously, the deviation from straightness is excessive.

If this condition occurs at any one of four or more positions of the gauge approximately equally spaced around the pipe circumference, the pipe does not comply with this particular requirement.

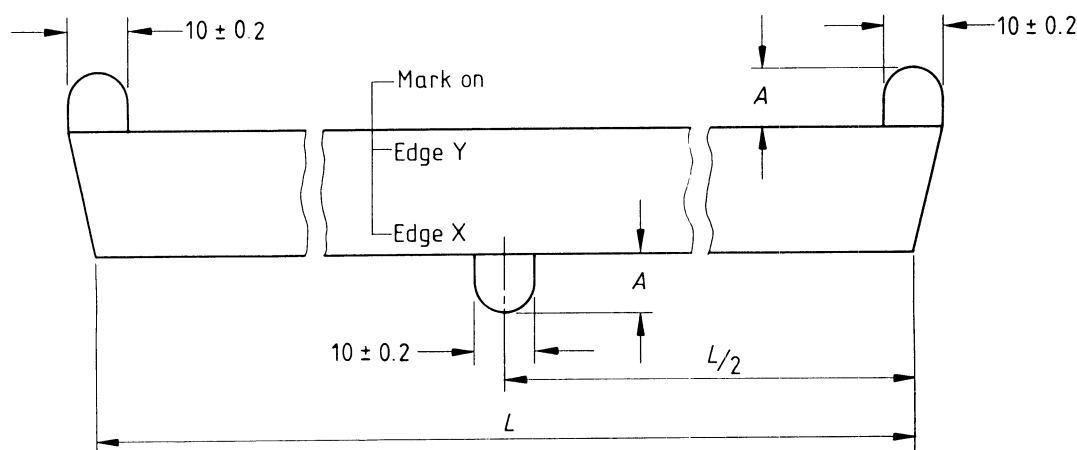

All dimensions are in millimetres.

$A = (5 \times \text{effective length of the pipe in m}) \text{ mm} \pm 5\%$.

$L = (\text{effective length of the pipe} - 10) \text{ mm (to the nearest mm)}$.

NOTE The studs should be detachable from the basic straightedge to facilitate checking and replacement.

Figure 4 — Gauge for assessing deviation from straightness

Appendix C Method of carrying out infiltration test

Fix the pipe horizontally in a tank with each end protruding as shown in Figure 5. Make a watertight seal between the sides of the tank and the pipe.

Fill the tank with water, completely immersing the pipe. Maintain the head of water in this tank at 50 mm above the crown of the pipe throughout the test.

Collect and measure the water passing through the pipe wall and calculate the infiltration rate R from the equation:

$$R = \frac{V}{L \times t}$$

where

- V is the volume of water (in l);
- L is the length of pipe in water (in m);
- t is the time during which water is collected (in min).

Appendix D Crushing load tests for pipes

D.1 Testing machine

D.1.1 A testing machine having a device that will apply the load at a uniform rate of about 30 kN per minute, or in increments of not more than 1.5 kN/m at the same rate, shall be used for making the test. The testing machine load shall be verified by the means detailed in BS 1610.

D.1.2 Ensure that the testing machine is substantial and rigid throughout so that the distribution of the load will not be affected appreciably by the deformation or yielding of any part and that, under the maximum load, the deflection of the unit is uniform throughout its length.

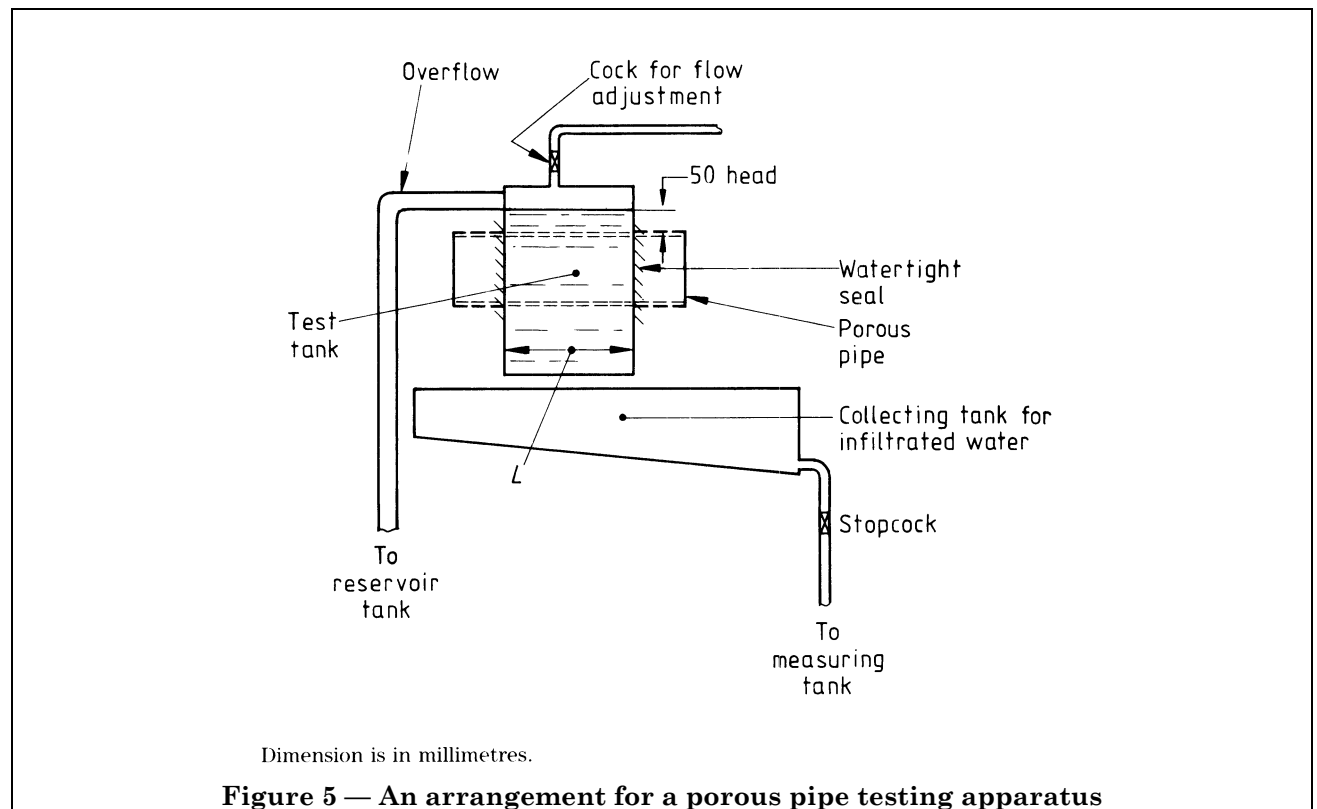

The bearing shall be as specified in **D.1.3** and shall be attached to the machine so as to receive and transmit uniformly the maximum loads required in the tests without lost motion, vibrations or sudden shock. The machine and bearings shall be designed to transmit the load in a vertical plane through the longitudinal centre lines of the bearings and unit.

Where the testing machine is so constructed that instead of a single load a number of equal individual loads, equally spread, are applied along the bearer, ensure that the resultant of all such individual loads acts at the centre of the overall length of the unit. The loaded length of the unit used in this test may extend over the joint, at the discretion of the manufacturer.

D.1.3 The bearings shall consist of a lower number, being a rigid beam, on which two bearing strips are symmetrically disposed parallel to a vertical plane passing through the longitudinal axis of the pipe, and an upper member, also being a rigid beam, on which one bearing strip is centred and disposed so that it lies in the vertical plane passing through the longitudinal axis of the pipe.

It is permissible to interpose a timber packing strip between the beam and the rubber bearing strip as shown in Figure 6.

NOTE The machine may apply the test load either upwards or downwards on the pipe under test. For convenience, the description given here is for top loading.

D.2 Procedure

D.2.1 The pipe to be tested shall be supported in a horizontal position on two bearings parallel to its longitudinal axis. Apply the load to it along the length of the pipe through a third bearing on top of the pipe.

D.2.2 Use a low carbon steel plate to face the upper flange of the bottom beam. Ensure that the facing is straight and free from warping or twisting and is centrally and permanently located on the flange of the beam. The cross section of the facing shall be rectangular, 330 mm × 25 mm minimum, without a joint and with the addition of steel wedge strips attached to it as shown in Figure 6.

D.2.3 The bearing strips shall consist of rubber cut or formed from material having a hardness between 50 IRHD and 60 IRHD measured in accordance with BS 903-A26. The top bearing strip shall be of rectangular cross section having a width of 150 mm and a thickness of not less than 25 mm and not more than 40 mm. The two bottom bearing strips shall be of equal thickness: 150 mm wide and 25 mm thick.

Use the single top bearing strip with the 150 mm face in contact with the unit. It may be positioned on the bearing by the use of wood or metal strips along its outside edges, provided the thickness of each positioning strip does not exceed one-half the thickness of the rubber bearing strip.

Lay the lower bearing strips on the 150 mm surface. They may be positioned on the bearing with wood or metal strips between them and adjacent to their outside edges, provided the thickness of each positioning strip does not exceed one-half the thickness of the rubber bearing strips. Ensure that the two strips are parallel and 25 mm apart for all nominal sizes of pipe.

The rubber bearing strips may be attached to the facings or, in the case of the single upper strip, directly to the upper beam by adhesive if desired, provided such method of attachment results in the strip(s) remaining firmly fixed in position when carrying the maximum load.

D.3 Loading

D.3.1 Apply the load to the top bearing at a point distant from the male end of the pipe equal to one-half of the overall length of the unit. Apply this load to the top bearing in such a way that the bearing is free to rotate in a vertical plane through the longitudinal centre lines of the top and bottom bearings.

D.3.2 Ensure that the loading of the pipe is a continuous operation and that the pipe is not under load longer than is required to apply the load.

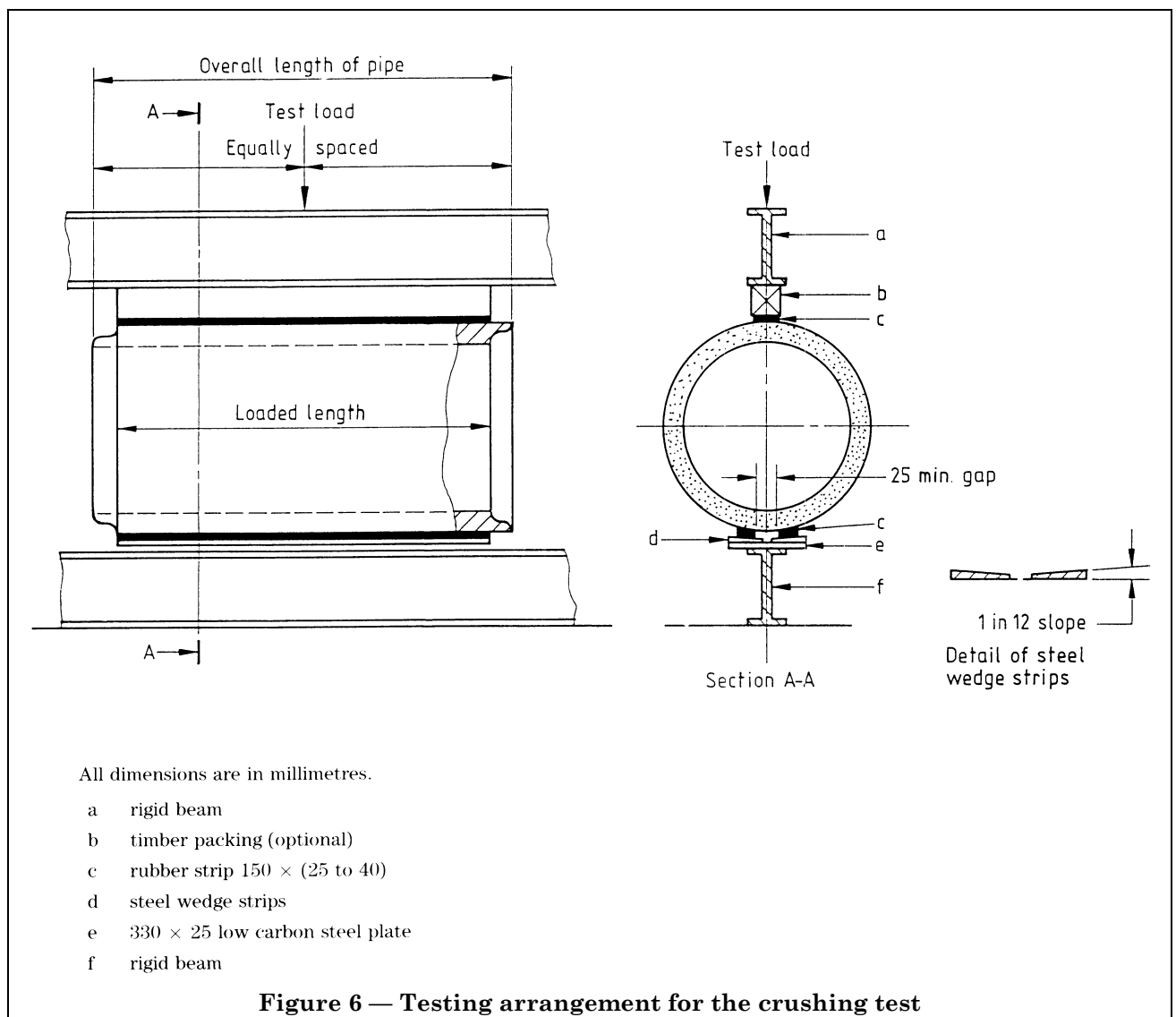

Appendix E Facilities for purchasers

The purchaser or his representative, by arrangement with the manufacturer, should at all reasonable times have free access to the places where the pipes are manufactured and tested, for the purpose of examining quality control procedures and records and of witnessing the testing and marking of units.

Representative samples of the aggregates should be supplied to the purchaser on request.

When required by the purchaser, evidence of satisfactory performance of the concrete manufactured with such aggregates should be made available at the time of placing the order.

Where the manufacturer is not covered by a scheme of third party certification, the purchaser should be permitted to select samples for test using the appropriate inspection criteria specified in this Part of BS 5911.

NOTE The allocation of the cost of carrying out any additional tests over and above the tests specified in this Part of BS 5911 is generally agreed between the manufacturer and the purchaser prior to testing.

Publication(s) referred to

- BS 12, *Specification for Portland cement.*
- BS 146, *Specification for Portland blastfurnace cements.*
- BS 882, *Specification for aggregates from natural sources for concrete.*
- BS 903, *Physical testing of rubber.*
- BS 903-A26, *Determination of hardness.*
- BS 1610, *Materials testing machines and force verification equipment.*
- BS 1881, *Testing concrete.*
- BS 1881-5, *Methods of testing hardened concrete for other than strength.*
- BS 3148, *Methods of test for water for making concrete (including notes on the suitability of the water).*
- BS 3797, *Specification for lightweight aggregates for masonry units and structural concrete.*
- BS 4027, *Specification for sulphate-resisting Portland cement.*
- BS 5075, *Concrete admixtures.*
- BS 5750, *Quality systems²⁾.*
- BS 5911, *Precast concrete pipes, fittings and ancillary products.*
- BS 5911-100, *Specification for unreinforced and reinforced pipes and fittings with flexible joints²⁾.*
- BS 6001, *Sampling procedures for inspection by attributes.*
- BS 6001-1, *Specification for sampling plans indexed by acceptable quality level (AQL) for lot-by-lot inspection.*
- BS 8110, *Structural use of concrete.*

²⁾ Referred to in the foreword only.

BSI — British Standards Institution

BSI is the independent national body responsible for preparing British Standards. It presents the UK view on standards in Europe and at the international level. It is incorporated by Royal Charter.

Revisions

British Standards are updated by amendment or revision. Users of British Standards should make sure that they possess the latest amendments or editions.

It is the constant aim of BSI to improve the quality of our products and services. We would be grateful if anyone finding an inaccuracy or ambiguity while using this British Standard would inform the Secretary of the technical committee responsible, the identity of which can be found on the inside front cover. Tel: 020 8996 9000. Fax: 020 8996 7400.

BSI offers members an individual updating service called PLUS which ensures that subscribers automatically receive the latest editions of standards.

Buying standards

Orders for all BSI, international and foreign standards publications should be addressed to Customer Services. Tel: 020 8996 9001. Fax: 020 8996 7001.

In response to orders for international standards, it is BSI policy to supply the BSI implementation of those that have been published as British Standards, unless otherwise requested.

Information on standards

BSI provides a wide range of information on national, European and international standards through its Library and its Technical Help to Exporters Service. Various BSI electronic information services are also available which give details on all its products and services. Contact the Information Centre. Tel: 020 8996 7111. Fax: 020 8996 7048.

Subscribing members of BSI are kept up to date with standards developments and receive substantial discounts on the purchase price of standards. For details of these and other benefits contact Membership Administration. Tel: 020 8996 7002. Fax: 020 8996 7001.

Copyright

Copyright subsists in all BSI publications. BSI also holds the copyright, in the UK, of the publications of the international standardization bodies. Except as permitted under the Copyright, Designs and Patents Act 1988 no extract may be reproduced, stored in a retrieval system or transmitted in any form or by any means – electronic, photocopying, recording or otherwise – without prior written permission from BSI.

This does not preclude the free use, in the course of implementing the standard, of necessary details such as symbols, and size, type or grade designations. If these details are to be used for any other purpose than implementation then the prior written permission of BSI must be obtained.

If permission is granted, the terms may include royalty payments or a licensing agreement. Details and advice can be obtained from the Copyright Manager. Tel: 020 8996 7070.