

Railway rolling stock materials —

Part 3: Specification for monobloc wheels for traction and trailing stock

ICS 45.040

Committees responsible for this British Standard

The preparation of this British Standard was entrusted by the Iron and Steel Standards Policy Committee (ISM/-) to Technical Committee ISM/69, upon which the following bodies were represented:

British Railways Board
British Steel Industry
London Underground Ltd.
Ministry of Defence
Railway Industry Association of Great Britain

This British Standard, having been prepared under the direction of the Iron and Steel Standards Policy Committee, was published under the authority of the Standards Board and comes into effect on
15 November 1992

© BSI 2008

First published February 1982
Second edition November 1992

The following BSI references relate to the work on this standard:
Committee reference ISM/69
Draft for Comment 91 37392 DC

ISBN 978 0 580 63229 7

Amendments issued since publication

Amd. No.	Date	Comments
16282	31 March 2006	See Foreword
Amendment No. 2	31 December 2008	See Foreword

Contents

	Page
Committees responsible	Inside front cover
Foreword	ii
<hr/>	
1 Scope	1
2 Definitions	1
3 Information to be supplied by the purchaser	1
4 Classification and heat treatment	1
5 Manufacture	3
6 Manufacturer's brand marks	13
7 Inspection	17
8 Type and number of tests	17
9 Test methods	21
10 Test results	21
11 Conclusion of inspection	22
12 Certification	22
13 Protection in transport	22
<hr/>	
Figure 1 — Key to symbols used in Table 4 (non-disc braked wheels)	8
Figure 2 — Key to symbols used in Table 5 (disc brake wheels)	12
Figure 3 — Oil injection hole	14
Figure 4 — Position of wear groove	15
Figure 5 — Correction of imbalance and position of residual stress	16
Figure 6 — Position of brand marks on wheels	17
Figure 7 — Position of tensile and impact test samples and test pieces	20
Figure 8 — Position of the Brinell hardness tests	23
<hr/>	
Table 1 — Chemical composition	2
Table 2 — Permitted variations of product analysis from the specified range for significant elements	2
Table 3 — Heat treatment condition and mechanical properties	3
Table 4 — Machining allowances and dimensional tolerances for solid wheels (non-disc braked)	5
Table 5 — Machining allowances and dimensional tolerances for solid wheels (disc braked)	9
Table 6 — Ready for assembly tolerances	13
Table 7 — Maximum residual imbalance	13
Table 8 — Type and number of tests	19
<hr/>	
Publications referred to	Inside back cover
<hr/>	

Foreword

This Part of BS 5892 was prepared under the direction of the Iron and Steel Standards Policy Committee and supersedes BS 5892-3:1982, which is withdrawn. BS 5892, which covers railway rolling stock material, is published in the following six Parts.

- *Part 1: Specification for axles for traction and trailing stock;*
- *Part 2: Specification for forged and rolled wheel centres;*
- *Part 3: Specification for monobloc wheels for traction and trailing stock;*
- *Part 4: Specification for forged and rolled tyres;*
- *Part 5: Specification for steel bars for retaining rings for tyred wheels;*
- *Part 6: Specification for wheelsets for traction and trailing stock.*

The format of this Part has been revised to incorporate the requirements for dimensional tolerances and surface finish for monobloc wheels which were previously included in BS 5892-6. This Part of BS 5892 is related to ISO 1005-6; however, it has not been possible to obtain equivalence. It is also related to UIC 812-3.

BS 5892-1, BS 5892-2, BS 5892-4 and BS 5892-6 have also been revised to ensure consistency with the requirements of this Part.

Product certification. Users of this British Standard are advised to consider the desirability of third party certification of product of conformity with this British Standard based on testing and continuing surveillance, which may be coupled with assessment of a supplier's quality systems against the appropriate Part of BS 5750.

Enquiries as to the availability of third party certification schemes will be forwarded by BSI to the Association of Certification Bodies. If a third party certification scheme does not already exist, users should consider approaching an appropriate body from the list of Association members.

The start and finish of text introduced or altered by Amendment No. 2:2009 is indicated in the text by tags $\overline{A_2}$ $\langle A_2 \rangle$. Minor editorial changes are not tagged.

This publication does not purport to include all the necessary provisions of a contract. Users are responsible for its correct application.

Compliance with a British Standard cannot confer immunity from legal obligations.

Summary of pages

This document comprises a front cover, an inside front cover, pages i and ii, pages 1 to 24, an inside back cover and a back cover.

This Standard has been updated (see copyright date) and may have had amendments incorporated. This will be indicated in the amendment table on the inside front cover.

1 Scope

This Part of BS 5892 specifies requirements for the manufacture, inspection and testing of rolled or forged monobloc wheels in the unmachined, finish machined or ready for assembly condition for traction and trailing stock. This Part of BS 5892 includes requirements for the dimensions, tolerances and surface finish that are to be adopted unless otherwise specified in the design drawing.

NOTE The titles of the publications referred to in this Part of BS 5892 are listed on the inside back cover.

A1) BS 5892-3 is not applicable to wheels to be fitted to axles designed to BS EN 13103 and BS EN 13104, the manufacture, inspection and testing of which are specified in BS EN 13261. **A1)**

2 Definitions

For the purposes of this Part of BS 5892 the following definitions apply.

2.1

unmachined

condition of a monobloc wheel in the forged and heat treated condition having undergone no machining operation other than proof machining by the manufacturer

2.2

finish machined

condition of a monobloc wheel where all the machining operations have been carried out apart from those required for assembly onto the axle

2.3

ready for assembly

condition of a monobloc wheel that has received all machining operations required for assembly

2.4

normal speed

operational speed up to and including 200 km/h

2.5

high speed

operational speed greater than 200 km/h

3 Information to be supplied by the purchaser

The following information to be supplied by the purchaser in the enquiry and order shall be fully documented:

- a) the number of this British Standard, i.e. BS 5892-3;

- b) a fully dimensioned drawing of the monobloc wheel;
- c) whether high or normal speeds apply (see 2.4 and 2.5);
- d) the grade of steel (see 4.1);
- e) the type of heat treatment required (see 4.2);
- f) the degree of finish (see 4.3);
- g) the maximum permissible amount of imbalance if not in accordance with Table 7 (see 5.8);
- h) the conditions for machining and the elimination of imbalance if not in accordance with Table 7 (see 5.8);
- i) the type of inspection and quality assurance system required (see clause 7);
- j) whether ultrasonic testing is required (see 9.7 and 10.7);
- k) whether checks on uniformity of rim hardness are required (see 8.3.6.1);
- l) whether assessment of residual stress is required (see 9.6);
- m) whether a statement giving the cast analysis and/or results of mechanical or other tests is required (see clause 12);
- n) whether a product check analysis is required (see 8.3.2 and 10.1);
- o) whether any special marking is required (see clause 6);
- p) the method of protection against corrosion and mechanical damage (see clause 13);
- q) whether static balancing tests are required (see 5.8).

4 Classification and heat treatment

4.1 Grades of steel

The grade(s) of steel shall be selected from those listed in Table 1 and Table 3 (see item d) of clause 3). Grades R1, R2, R3, R6, R7, R8 and R9 shall have the composition and properties given in Table 1, Table 2 and Table 3.

Table 1 — Chemical composition

Grade of steel	Cast composition										
	C max.	Si max.	Mn max.	P max.	S max.	Cr max.	Cu max.	Mo max.	Ni max.	V max.	Cr + Mo + Ni max.
	%	%	%	%	%	%	%	%	%	%	%
R1	—	0.50	1.20	0.040	0.040	0.30	0.30	0.08	0.30	0.05	0.60
R2	—	0.50	1.20	0.040	0.040	0.30	0.30	0.08	0.30	0.05	0.60
R3	0.70	0.50	0.90	0.040	0.040	0.30	0.30	0.08	0.30	0.05	0.60
R6	0.48	0.40	0.75	0.040	0.040	0.30	0.30	0.08	0.30	0.05	0.60
R7	0.52	0.40	0.80	0.040	0.040	0.30	0.30	0.08	0.30	0.05	0.60
R8	0.56	0.40	0.80	0.040	0.040	0.30	0.30	0.08	0.30	0.05	0.60
$\overline{A_2}$ RS8	0.56	1.10	1.10	0.040	0.040	0.30	0.30	0.08	0.30	0.05	0.60 $\overline{A_2}$
R9	0.60	0.40	0.80	0.040	0.040	0.30	0.30	0.08	0.30	0.05	0.60

Table 2 — Permitted variations of product analysis from the specified range for significant elements

Element	Range in which maximum of specified element falls	Variation on specified range
Carbon	Up to and including 0.50	+ 0.03 - 0
	Over 0.50, up to and including 0.70	+ 0.04 - 0
$\overline{A_2}$ Silicon	Up to and including 0.50	+ 0.03 - 0
	Over 0.50, up to and including 0.70	+ 0.04 - 0
	Over 0.70, up to and including 1.10	+ 0.06 - 0 $\overline{A_2}$
Manganese	Up to and including 1.0	+ 0.04 - 0
	Over 1.0, up to and including 1.20	+ 0.08 - 0
Sulfur	$\overline{A_2}$ Up $\overline{A_2}$ to and including 0.040	+ 0.006 - 0
Phosphorus	$\overline{A_2}$ Up $\overline{A_2}$ to and including 0.040	+ 0.006 - 0

4.2 Heat treatment condition

The wheels shall be supplied in one of the following conditions (see item e) of clause 3):

- a) untreated, in the case of steels R1, R2 and R3, which shall be designated by the letter U;
- b) normalized or normalized and tempered, in the case of steels R1, R2 and R3, which shall be designated by the letter N;

c) rim chilled, in the case of steels R6, R7, R8, $\overline{A_2}$, RS8 $\overline{A_2}$ and R9, which shall be designated by the letter T;

d) immersion quenched and tempered in the case of steels R6, R7, R8 and R9, which shall be designated by the letter E.

Examples. R3N is steel grade R3 delivered in the normalized or normalized and tempered condition. R7E is steel grade R7 delivered in the immersion quenched and tempered condition.

Table 3 — Heat treatment condition and mechanical properties

Grade of steel	Heat treatment condition on delivery (see 4.2)	Mechanical properties			
		Tensile strength R_m	Elongation A , min. ^a	Minimum charpy U impact value at 20 °C KU ^b	Brinell hardness range
		N/mm ²	%	J	HB
R1	U	600 to 720	12	—	179 to 217
	N	600 to 720	18	15	179 to 217
R2	U	700 to 840	9	—	207 to 248
	N	700 to 840	14	10	207 to 248
R3	U	800 to 940	7	—	235 to 277
	N	800 to 940	14	10	235 to 277
R6	T (Rim)	770 to 890	15	15	229 to 262
	E (Rim)	730 to 890	15	15	217 to 262
	T (Web)	740 $\sqrt{A_2}$ max. $\sqrt{A_2}$	16	—	—
R7	T (Rim)	820 to 940	14	15	241 to 277
	E (Rim)	780 to 940	14	15	229 to 277
	T (Web)	760 $\sqrt{A_2}$ max. $\sqrt{A_2}$	16	—	—
R8	T (Rim)	860 to 980	13	15	255 to 285
	E (Rim)	820 to 980	13	15	241 to 285
	T (Web)	820 $\sqrt{A_2}$ max. $\sqrt{A_2}$	16	—	—
$\sqrt{A_2}$ RS8 ^c	T (Rim)	900 to 1 020 max.	13	15	262 to 302
	T (Web)	900 max.	16	—	— $\sqrt{A_2}$
R9	T (Rim)	900 to 1 050	12	10	262 to 311
	E (Rim)	860 to 1 050	12	10	255 to 311
	T (Web)	880 $\sqrt{A_2}$ max. $\sqrt{A_2}$	14	—	—

^a A is the percentage elongation after fracture on a gauge length $L_0 = 5.65 \sqrt{S_0}$ where S_0 is the original cross-sectional area of the test piece.

^b Mean value of three tests: one of the individual results may be lower than the minimum value given in this table provided it is not less than 70 % of the minimum.

$\sqrt{A_2}$ ^c RS8T offers improved rolling contact fatigue (RCF) resistance. It may be used as an alternative to disc-braked wheelsets designed to R8T requirements. It should not be used for tread-braked wheels. If it is to be considered for applications involving higher permissible design stresses than R8T then it should be demonstrated that it is appropriate for such applications. $\sqrt{A_2}$

4.3 Degree of finish

The wheels shall be supplied in one of the following degrees of finish (see clause 2 and item f) of clause 3):

- unmachined;
- finish machined;
- ready for assembly.

5 Manufacture

5.1 Steelmaking

The wheels shall be made from steel produced by the electric process or the basic oxygen process.

The steel shall be killed in the furnace or in the ladle and treated to ensure that the finished wheels have a grain size of 5 to 8 as determined by the method in Appendix F of BS 4490:1989. Ingots shall be bottom poured.

5.2 Manufacture of the wheels

Wheels shall be manufactured by hot forging and rolling from one of the following:

- ingots; or
- rolled or forged bars; or
- continuously cast bars.

The ingot or bar sections shall be rough shaped and punched using a forging hammer or press and finally shaped by forging or rolling.

Precautions shall be taken during hot working to ensure that material is not damaged by overheating or by grain growth due to high finish working temperatures.

NOTE Generally, forging should not be done at temperatures above 1 260 °C and should terminate between 850 °C and 1 000 °C.

After forging or rolling and stamping of the identification marks, the wheels shall be left to cool in still air.

5.3 Hydrogen cracking (flakes)

If the steel has not been vacuum degassed precautions shall be taken to avoid the formation of hydrogen cracks (flakes).

5.4 Non-conforming material

Non-conforming material which would prevent compliance with 10.8 shall be removed before or during the manufacture of the wheels. The wheels shall be sound throughout without defects detrimental to their end use.

5.5 Identification of the wheels during manufacture

All ingots, bars, forgings and wheels shall be marked at each stage of manufacture so that each wheel can be identified as specified in clause 6. Where the identification marks are stamped, and differ from the final identification marks specified in clause 6, they shall not be visible on the finished wheel after machining.

5.6 Heat treatment

After hot working wheels shall undergo the specified heat treatment (see item e) of clause 3 and 4.2). Details of heat treatment temperatures and times shall be recorded.

In the case of rim chilled (T) and immersion quenched and tempered (E) wheels the tempering temperature shall be not less than 500 °C.

The required heat treatment operations shall ensure:

- a) uniformity of structure and properties of comparable parts of the same wheel;

- b) uniformity of structure and properties in all wheels of the same heat treatment batch;
- c) that the forging is sufficiently undistorted to enable the wheel to be produced as specified in 10.9.

5.7 Dimensions

Unless otherwise specified on the wheel drawing or order, the machining allowances and dimensional tolerances shall be those given in Table 4, Table 5 and Table 6 (see also Figure 1 and Figure 2).

NOTE 1 In the ready for assembly condition, whilst every effort should be made to ensure size conformity, it is permissible, unless otherwise specified, for the internal hub bore dimension to be tailored to a specific axle. However, the maximum size deviation from the drawing should be no more than 0.5 mm such that in all instances the assembly requirements specified in BS 5892-6 are achieved.

The bore of the wheel shall be perpendicular to the plane of the wheel and concentric with the tread within the run-out requirements of the finished assembly as specified in BS 5892-6.

The bore shall not have a lead-in taper.

Provision shall be made for wheel removal by means of the oil injection method. The oil injection groove and the injection hole parameters shall be in accordance with Figure 3. The edges of the oil injection grooves and the oil injection holes shall be blended out to remove sharp corners.

The tread and flange contour shall be as specified on the appropriate drawing.

NOTE 2 This may be machined before or after assembly of the wheel onto the axle.

When specified, a limited wear groove shall be provided as shown in Figure 4.

Table 4 — Machining allowances and dimensional tolerances for solid wheels (non-disc brake)

Part	Designation	Symbol for machining allowance (see Figure 1)	Symbol for dimension (see Figure 1)	Unmachined ^a						Finish machined ^a				Ready for assembly ^a					
				Machining allowance		Tolerance		Machining allowance		Tolerance		Normal speed		High speed		Tolerance			
				Normal speed	High speed	Normal speed	High speed	Normal speed	High speed	Normal speed	High speed	Normal speed	High speed	Normal speed	High speed	Normal speed	High speed		
Rim	External diameter	A	a	mm	6	mm	+12 -0	mm	—	mm	—	mm	—	mm	—	mm	—	mm	—
		—	a ₁	—	—	—	—	—	—	—	—	—	—	—	—	—	—	—	—
	Total run-out ^b in radial direction (wheel tread)	—	b	—	—	—	—	—	—	—	—	—	—	—	—	—	—	—	—
	Internal diameter (outer)	C	c	3 ^c	—	mm	+0 -10	mm	—	mm	—	mm	—	mm	—	mm	—	mm	—
		—	c ₁	—	—	—	—	—	—	—	—	—	—	—	—	—	—	—	—
	Total run-out ^b in radial direction (outer)	—	d	—	—	—	—	—	—	—	—	—	—	—	—	—	—	—	—
	Internal diameter (inner)	E	e	3 ^c	—	mm	+0 -10	mm	—	mm	—	mm	—	mm	—	mm	—	mm	—
		—	e ₁	—	—	—	—	—	—	—	—	—	—	—	—	—	—	—	—
	Total run-out ^b in radial direction (inner)	—	f	—	—	—	—	—	—	—	—	—	—	—	—	—	—	—	—
	Width	G	g	5	—	mm	+8 -0	mm	—	mm	—	mm	—	mm	—	mm	—	mm	—
	—	g ₁	—	—	—	—	—	—	—	—	—	—	—	—	—	—	—	—	
Diameter at wear groove	Y	y	—	—	—	—	—	—	—	—	—	—	—	—	—	—	—	—	

Table 4 — Machining allowances and dimensional tolerances for solid wheels (non-disc brake)

Part	Designation	Symbol for machining allowance (see Figure 1)	Symbol for dimension (see Figure 1)	Unmachined ^a				Finish machined ^a				Ready for assembly ^a					
				Machining allowance		Tolerance		Machining allowance		Tolerance		Tolerance					
				Normal speed	High speed	Normal speed	High speed	Normal speed	High speed	Normal speed	High speed	Normal speed	High speed				
	Buckle ^d	—	<i>h</i>	mm	mm	mm	mm	mm	mm	mm	mm	mm	mm	mm	mm		
	Total run-out ^b in axial direction	—	<i>j</i>	—	3	—	—	—	—	—	—	—	—	—	—		
	Parallelism	—	<i>k</i>	—	—	—	—	—	—	—	—	—	—	—	—		
	Tread profile	—	—	—	—	—	—	—	—	—	—	—	—	—	—		
The tolerance is to be indicated on the drawing																	
Hub	External diameter	<i>M</i>	<i>m</i>	10	10	+20 -0	+20 -0	—	—	—	—	—	—	—	—	—	
		—	<i>m</i> ₁	—	—	—	—	—	—	—	—	±5	±5	±5	±5	±5	
	Total run-out ^b in radial direction	—	<i>n</i>	—	—	15	15	—	—	—	—	6	3	6	3	3	
	Internal diameter	<i>P</i>	<i>p</i>	10	10	+0 -20	+0 -20	—	—	—	—	—	+0	+0	—	—	—
		<i>P</i> ₁	<i>p</i> ₁	—	—	—	—	5	5	—	—	—	—	—	—	—	e
		—	<i>p</i> ₂	—	—	—	—	—	—	—	—	—	—	—	—	—	e
	Length	<i>R</i>	<i>r</i>	10	10	+10 -0	+10 -0	—	—	—	—	—	—	—	—	—	—
		—	<i>r</i> ₁	—	—	—	—	—	—	—	—	—	—	—	—	—	—
		—	<i>s</i>	—	—	—	—	—	—	—	—	—	—	—	—	—	—
		Hub to wheel rim overhang	—	—	—	—	—	—	—	—	—	—	—	—	—	—	—

Table 4 — Machining allowances and dimensional tolerances for solid wheels (non-disc brake)

Part	Designation	Symbol for machining allowance (see Figure 1)	Symbol for dimension (see Figure 1)	Unmachined ^a						Finish machined ^a				Ready for assembly ^a			
				Machining allowance		Tolerance		Machining allowance		Tolerance		Normal speed	High speed	Normal speed	High speed	Normal speed	High speed
				Normal speed	High speed	Normal speed	High speed	Normal speed	High speed	Normal speed	High speed						
Web	Position of the web at the connection with the rim and the hub on the centre line of the web	—	t	mm	mm	mm	mm	mm	mm	mm	mm	mm	mm	mm	mm		
				—	—	4	4	—	—	—	6	3	6	3			
				mm	mm	mm	mm	mm	mm	mm	mm	mm	mm	mm	mm		
Web	Thickness at the connection with the rim	U	u	5 ^c	mm	mm	mm	mm	mm	mm	mm	mm	mm	mm	mm		
				—	+6	-0	—	—	—	—	—	—	—	—	—		
				mm	mm	mm	mm	mm	mm	mm	mm	mm	mm	mm	mm		
Web	Thickness at the connection with the hub	V	v	8 ^c	mm	mm	mm	mm	mm	mm	mm	mm	mm	mm	mm		
				—	+10	-0	—	—	—	—	—	—	—	—	—		
				mm	mm	mm	mm	mm	mm	mm	mm	mm	mm	mm	mm		
Web	Thickness at the connection with the hub	—	v_1	mm	mm	mm	mm	mm	mm	mm	mm	mm	mm	mm	mm		
				—	+10	-0	—	—	—	—	—	—	—	—	—		
				mm	mm	mm	mm	mm	mm	mm	mm	mm	mm	mm	mm		

^a Terms are as defined in clause 2.

^b The geometrical term total run-out tolerance is defined in BS 308-3.

^c If intended to be unmachined at finished condition these allowances become inapplicable.

^d The unmachined wheel should be placed wheel flange side down on a flat annular ring, the buckle dimensions being measured by the maximum gap between the wheel flange and the ring.

^e According to the specification on the drawing.

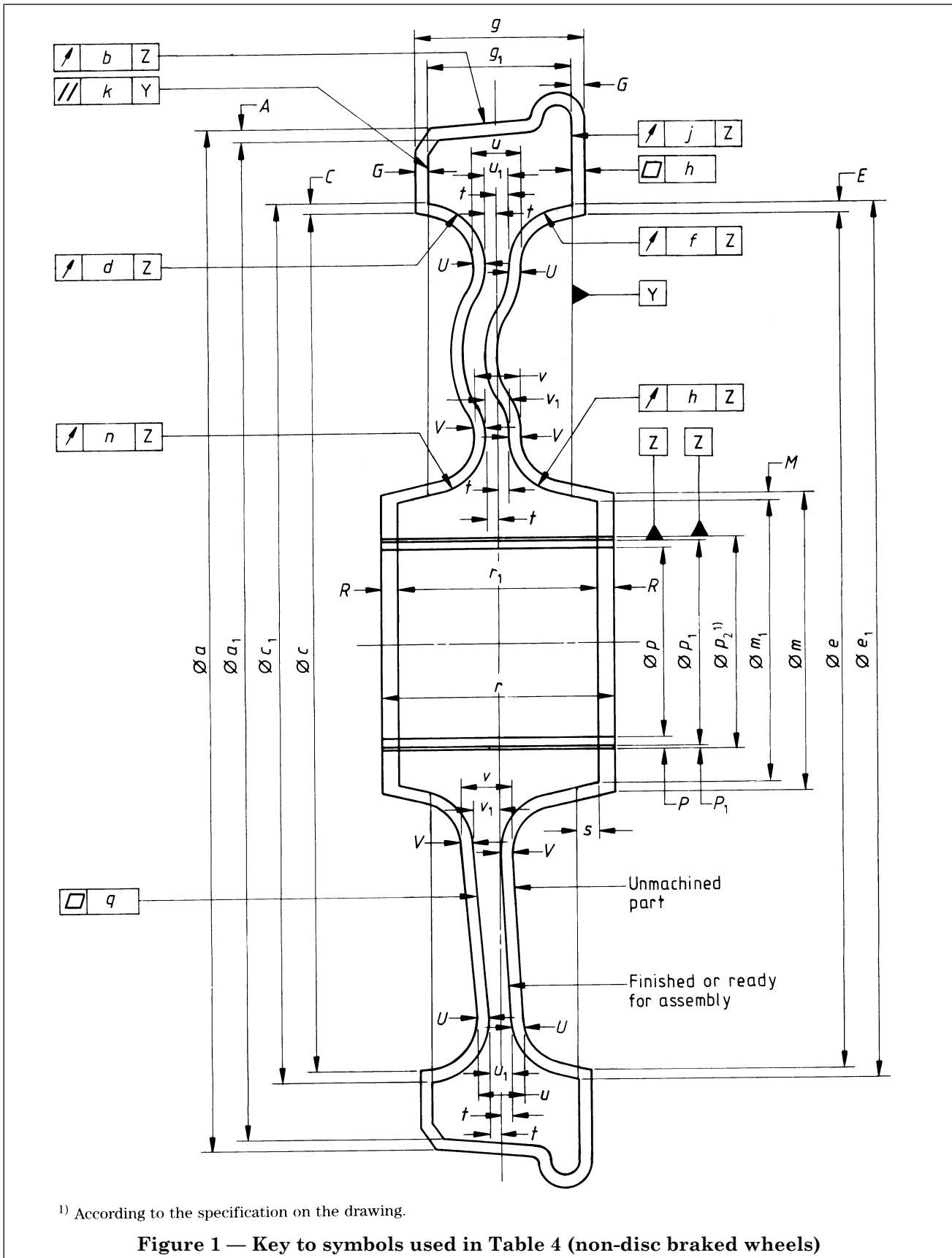

Table 5 — Machining allowances and dimensional tolerances for solid wheels (disc braked)

Part	Designation	Symbol for machining allowance (see Figure 2)	Symbol for dimension (see Figure 2)	Unmachined ^a						Finished machined ^a						Ready for assembly ^a	
				Machining allowance			Tolerance			Machining allowance			Tolerance			Normal speed	High speed
				Normal speed	High speed	mm	Normal speed	High speed	mm	Normal speed	High speed	mm	Normal speed	High speed	mm	Normal speed	High speed
Rim	External diameter	<i>A</i>	<i>a</i>	6	6	mm	+12 -0	+12 -0	mm	—	—	mm	—	—	mm	—	—
		—	<i>a</i> ₁	—	—	mm	—	—	mm	—	—	mm	+3 -0	+1 -0	mm	+3 -0	+1 -0
	Total run-out ^b in radial direction (wheel tread)	—	<i>b</i>	—	—	mm	—	—	mm	—	—	mm	—	—	mm	0.2	0.2
	Internal diameter (outer)	<i>C</i>	<i>c</i>	3 ^c	3	mm	+0 -10	+0 -10	mm	—	—	mm	— ^c	—	mm	—	—
		—	<i>c</i> ₁	—	—	mm	—	—	mm	—	—	mm	+0 -3	+0.5 -0.5	mm	+0 -3	+0.5 -0.5
	Total run-out ^b in radial direction (outer)	—	<i>d</i>	—	—	mm	—	—	mm	—	—	mm	—	—	mm	0.5	0.2
	Internal diameter (inner)	<i>E</i>	<i>e</i>	3 ^c	3	mm	+0 10	+0 -10	mm	—	—	mm	—	—	mm	—	—
		—	<i>e</i> ₁	—	—	mm	—	—	mm	—	—	mm	+0 -3	+0.5 -0.5	mm	+0 -3	+0.5 -0.5
	Total run-out ^b in radial direction (inner)	—	<i>f</i>	—	—	mm	—	—	mm	—	—	mm	—	—	mm	0.5	0.2

Table 5 — Machining allowances and dimensional tolerances for solid wheels (disc braked)

Part	Designation	Symbol for machining allowance (see Figure 2)	Symbol for dimension (see Figure 2)	Unmachined ^a						Finished machined ^a						Ready for assembly ^a			
				Machining allowance			Tolerance			Machining allowance			Tolerance			Tolerance			
				Normal speed	High speed	mm	Normal speed	High speed	mm	Normal speed	High speed	mm	Normal speed	High speed	mm	Normal speed	High speed	mm	mm
				mm	mm	mm	mm	mm	mm	mm	mm	mm	mm	mm	mm	mm	mm	mm	mm
A)	Width	<i>G</i>	<i>g</i>	5	+8 -0	—	—	—	—	—	—	—	—	—	—	—	—		
		—	<i>g</i> ₁	—	—	—	—	—	—	—	—	—	—	—	+1 -1	+1 -1	—		
	Diameter at wear groove	<i>Y</i>	<i>y</i>	—	—	—	—	—	—	—	—	—	—	—	+2 -0	+2 -0	+2 -0	√A1	
	Buckle ^d	—	<i>h</i>	—	3	—	—	—	—	—	—	—	—	—	—	—	—	—	
	Total run-out ^b in axial direction	—	<i>j</i>	—	—	—	—	—	—	—	—	—	—	—	0.25	0.25	0.25	0.25	
Parallelism	—	<i>k</i>	—	—	—	—	—	—	—	—	—	—	—	0.25	0.25	0.25	0.25		
Tread profile																			
The tolerance is to be indicated on the drawing																			
Hub	External diameter	<i>M</i>	<i>m</i>	10	+20	—	—	—	—	—	—	—	—	—	—	—	—	—	
		—	<i>m</i> ₁	—	-0	—	—	—	—	—	—	—	—	—	+0 -3	+0.5 -0.5	+0 -3	+0.5 -0.5	
	Total run-out ^b in radial direction	—	<i>n</i>	—	15	—	—	—	—	—	—	—	—	—	2	1	2	1	
Internal diameter		<i>P</i>	<i>p</i>	10	+0 -20	—	—	—	—	—	—	—	—	—	—	—	—	—	
		<i>P</i> ₁	<i>p</i> ₁	—	—	5	—	—	—	—	—	—	—	—	+0 -3	+0 -3	—	—	
		—	<i>p</i> ₂	—	—	—	—	—	—	—	—	—	—	—	—	—	e	e	

Table 5 — Machining allowances and dimensional tolerances for solid wheels (disc braked)

Part	Designation	Symbol for machining allowance (see Figure 2)	Symbol for dimension (see Figure 2)	Unmachined ^a						Finished machined ^a						Ready for assembly ^a	
				Machining allowance			Tolerance			Machining allowance			Tolerance			Normal speed	High speed
				Normal speed	High speed	mm	Normal speed	High speed	mm	Normal speed	High speed	mm	Normal speed	High speed	mm		
Length	R	—	r	mm	10	mm	+10 +0	mm	+10 +0	mm	—	mm	—	mm	—	mm	—
	—	—	r_1	—	—	—	—	—	—	—	—	—	—	—	—	—	—
	—	—	s	—	—	—	—	—	—	—	—	—	—	—	—	—	—
Web	Hub to wheel rim overhang	—	s	—	—	—	—	—	—	—	—	—	—	—	—	—	—
	Position of the web at the connection with the rim and the hub on the centre line of the web	—	t	—	—	4	4	4	4	—	—	—	—	—	—	—	—
	Thickness	U	u	5 ^c	5	+6	+6	+6	—	—	—	—	—	—	—	—	—
Total run-out in axial direction	—	—	u_1	—	—	—0	—0	—0	—0	—	—	—	—	—	—	—	—
	—	—	v	—	—	—	—	—	—	—	—	—	—	—	—	—	—
	—	—	w	—	—	—	—	—	—	—	—	—	—	—	—	—	—
True position of holes	—	—	x	—	—	—	—	—	—	—	—	—	—	—	—	—	—
	—	—		—	—	—	—	—	—	—	—	—	—	—	—	—	—

^a Terms are as defined in clause 2.

^b The geometrical term total run-out tolerance is defined in BS 308-3.

^c If intended to be unmachined at finished condition these allowances become inapplicable.

^d The unmachined wheel should be placed wheel flange side down on a flat annular ring, the buckle dimensions being measured by the maximum gap between the wheel flange and the ring.

^e According to the specifications on the drawing.

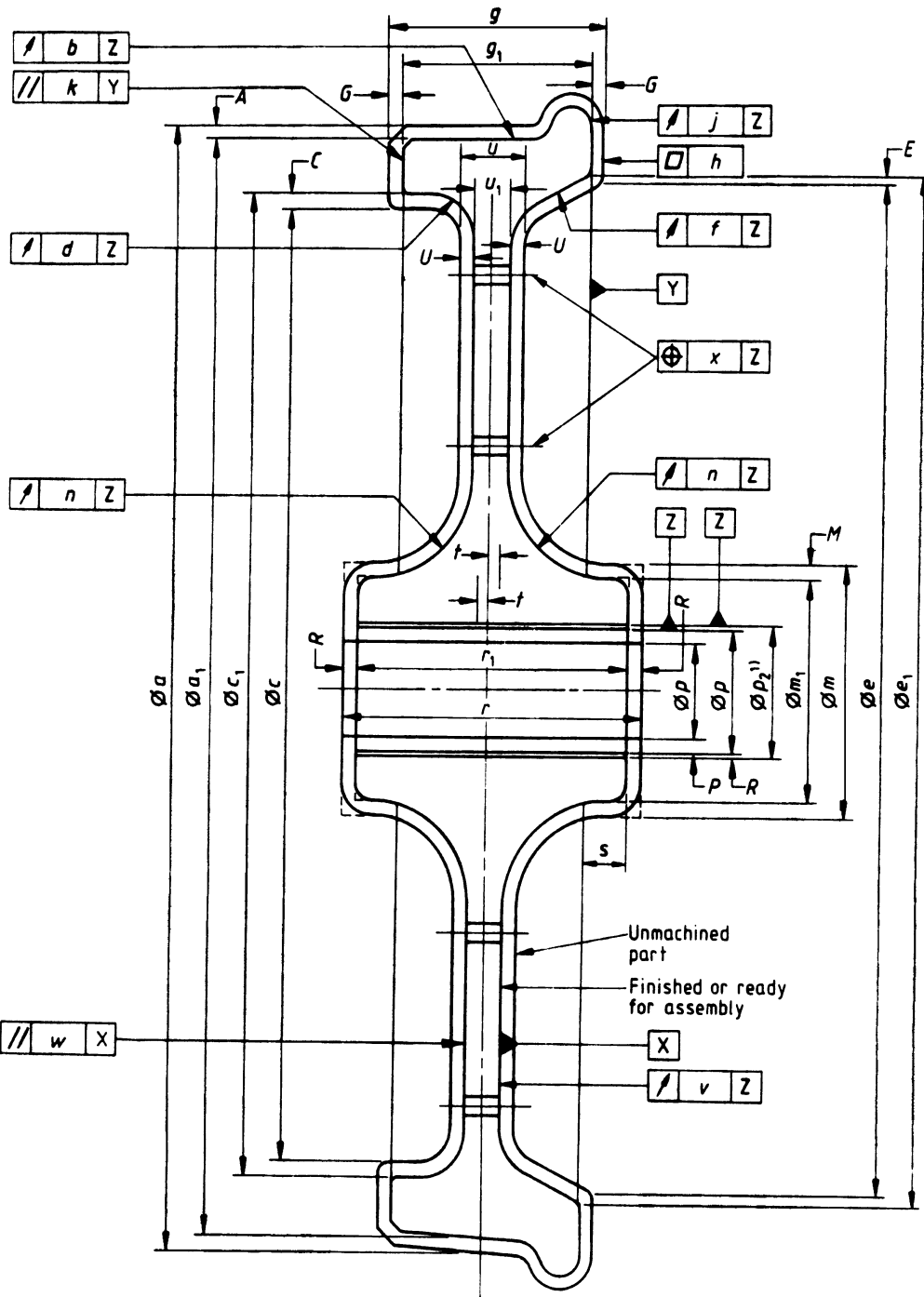

¹⁾ According to the specification on the drawing.

Figure 2 — Key to symbols used in Table 5 (disc braked wheels)

Table 6 — Ready for assembly tolerances

Radius at axle bore entry end	3 mm
Hub bore surface finish ^a	3.2 µm max.
Hub end faces — surface finish	12.5 µm max.
Hub end face (bearing surface)	1.6 µm max.
Parallel bores (maximum taper) ^b	0.00025 mm/mm axial length
Bore cylindricity ^c	0.03 mm max.
Surface finish tread and flange	12.5 µm max.
\sqrt{A} Non-specified areas	12.5 µm max. \sqrt{A}
^a The maximum sampling length shall be 8 mm. ^b Where a taper exists the larger diameter should be at the inboard end of the hub. For hubs larger than 120 mm the taper should conform to the bore cylindricity tolerance. ^c For the definition of cylindricity tolerance (see BS 308-3).	

5.8 Elimination of imbalance

Unless otherwise specified by the purchaser, imbalance shall be eliminated by machining the fillet between the web and the rim off-centre on the flange side (see Figure 5). The maximum residual imbalance permissible shall be as given in Table 7. The thickness of the metal removed shall not exceed 4 mm and the resultant surface shall be carefully blended into adjacent material.

Table 7 — Maximum residual imbalance

Maximum speed	Maximum residual imbalance
	g·m
Wheels for stock running at a speed greater than 200 km/h	50
Wheels for stock running at a speed greater than 120 km/h up to and including 200 km/h	75
Wheels for stock running at a speed of up to and including 120 km/h	125

5.9 Removal of any surface defects

NOTE It is permissible for the manufacturer to eliminate superficial defects prior to static balancing by chipping or by careful grinding provided that:

- a) no heat cracking is produced;
- b) the dimensional tolerances are maintained and;
- c) magnetic particle crack detection is used to confirm that the defect is completely eliminated.

Rectification by the deposition of metal by any means shall not be carried out.

6 Manufacturer's brand marks

Unless the purchaser indicates that special marking is required (see item o) of clause 3), each wheel shall be identified by the manufacturer with stamp marks in the position shown in Figure 6. The markings shall include the following:

- a) the number of this British Standard, i.e. BS 5892-3¹⁾;
- b) the manufacturer's mark;
- c) the cast number;
- d) the grade of steel and the heat treatment condition, e.g. R8E;
- e) the date of manufacture (month and last two figures of the year of production);
- f) the inspector's mark.

¹⁾ Marking BS 5892-3 on or in relation to a product represents a manufacturer's declaration of conformity, i.e. a claim by or on behalf of the manufacturer that the product meets the requirements of the standard. The accuracy of the claim is therefore solely the responsibility of the person making the claim. Such a declaration is not to be confused with third party certification of conformity, which may also be desirable.

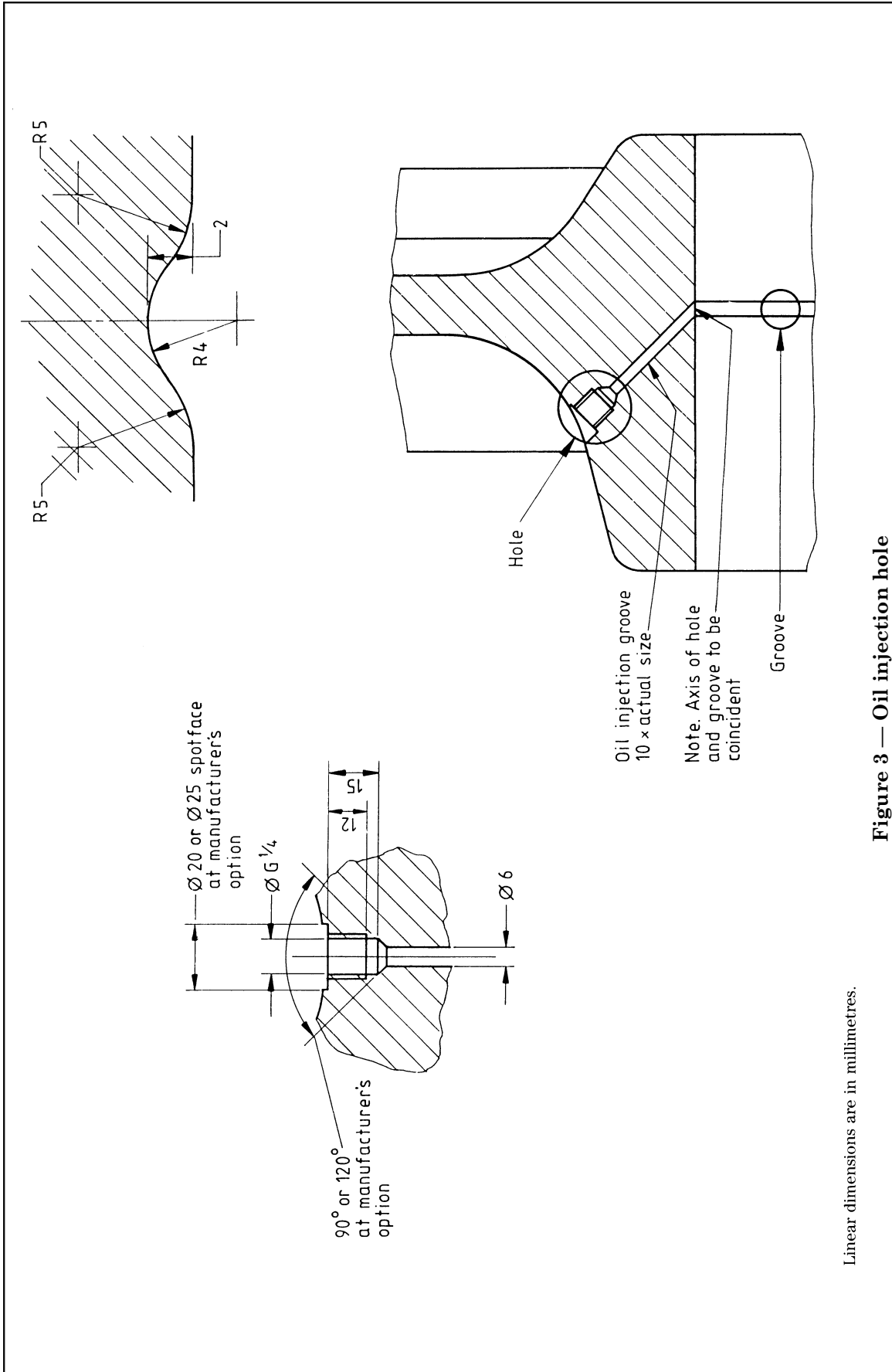

Linear dimensions are in millimetres.

Figure 3 — Oil injection hole

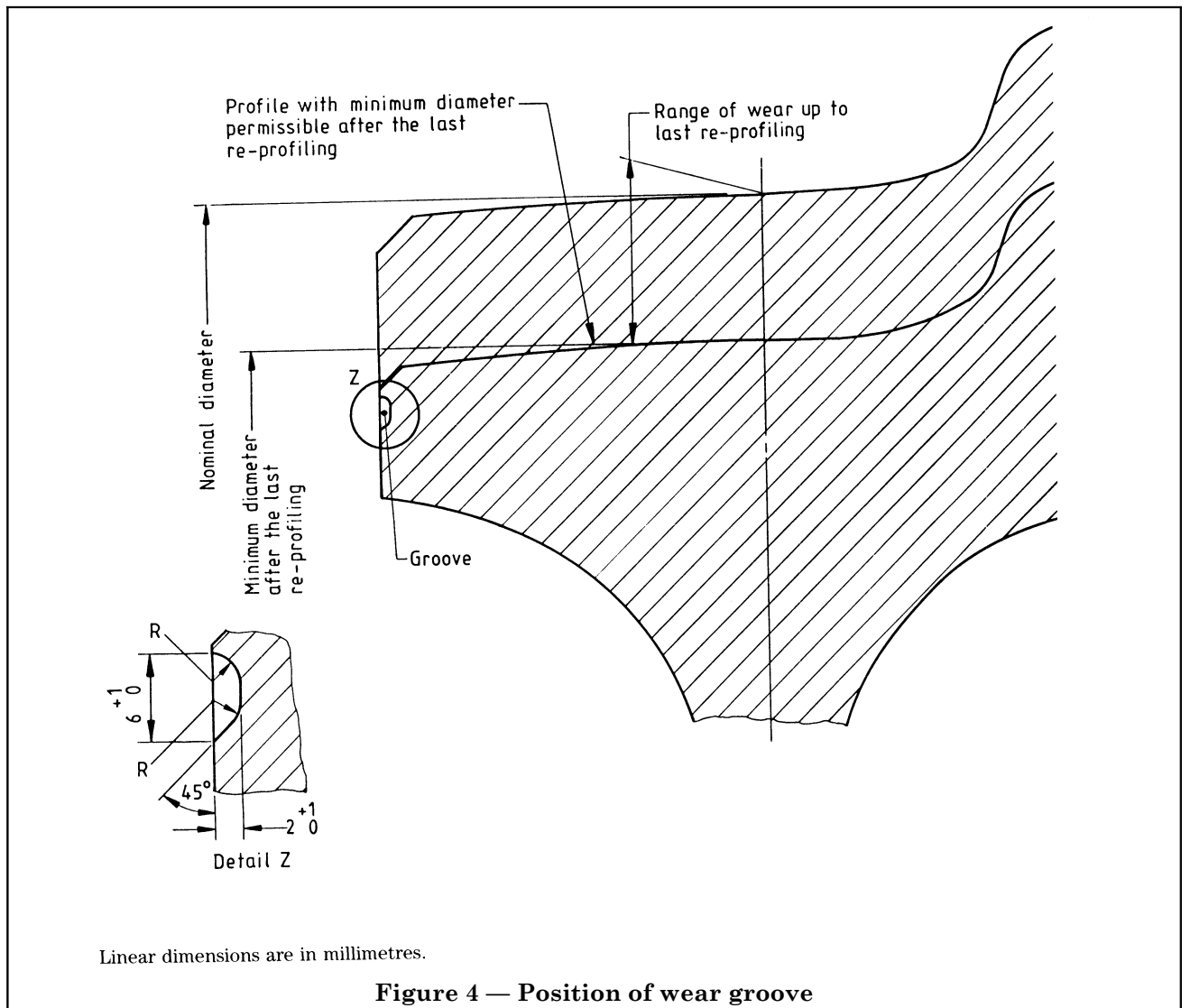

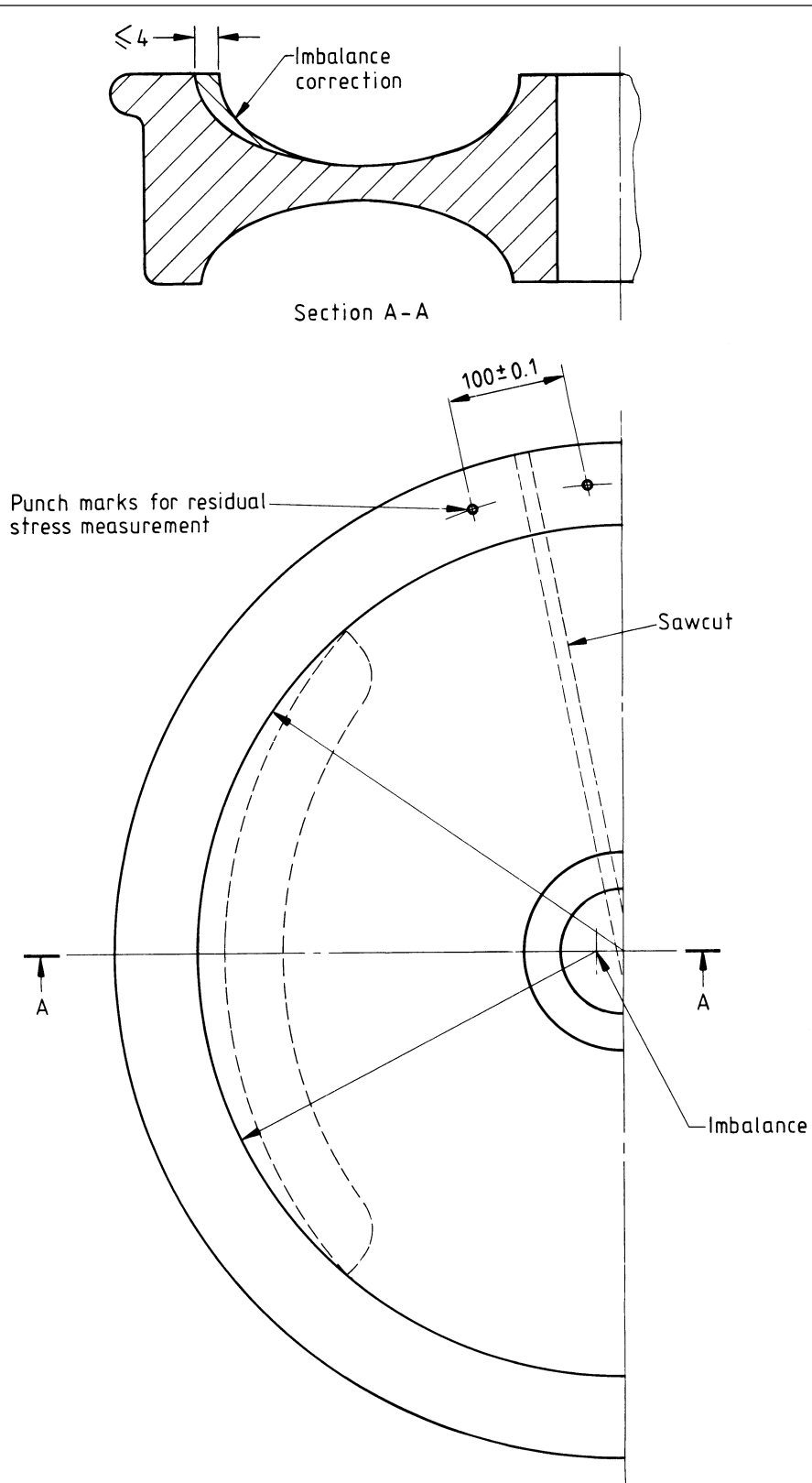

Dimensions are in millimetres.

Figure 5 — Correction of imbalance and position of residual stress test

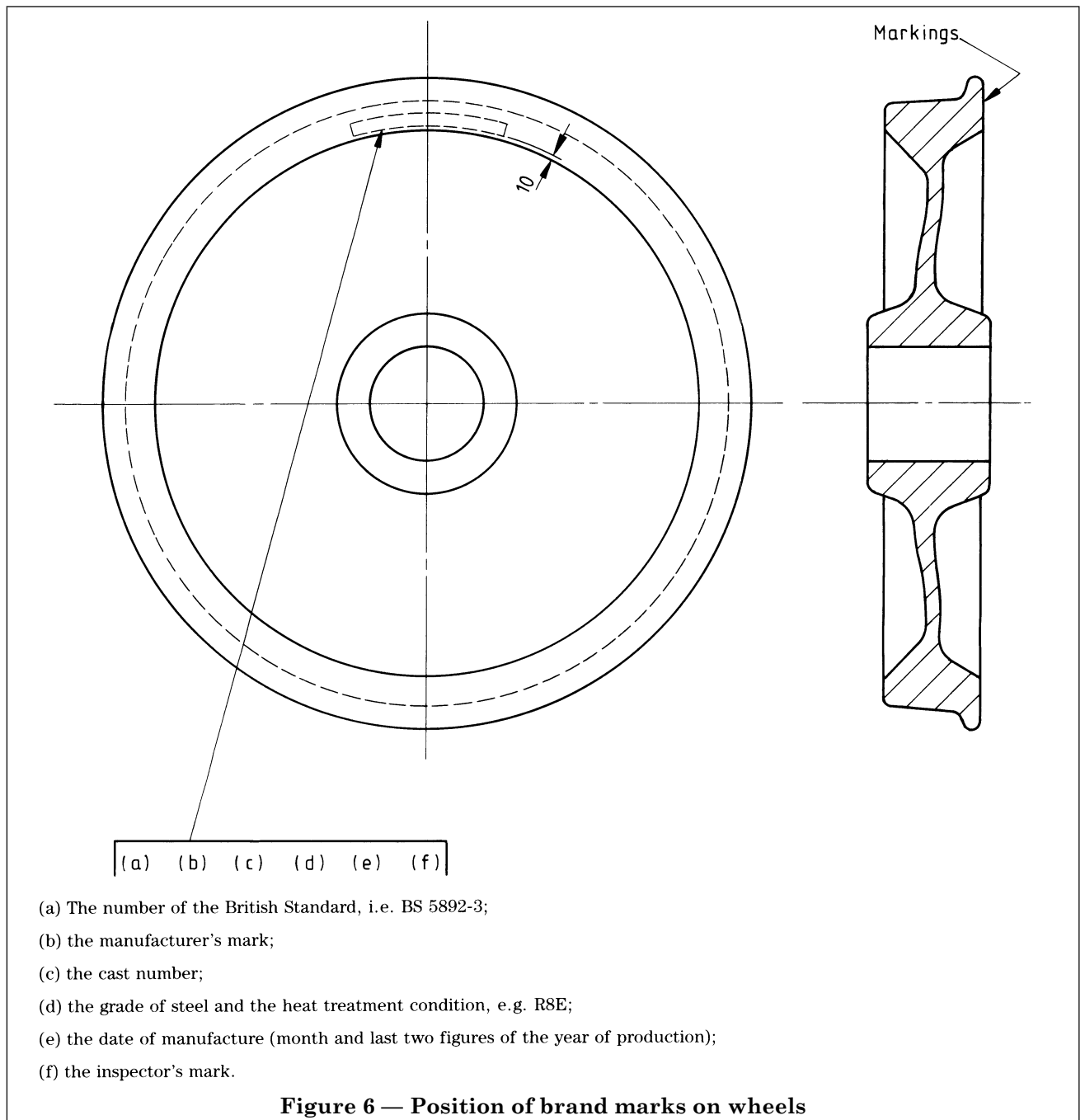

7 Inspection

The inspection of wheels shall be undertaken in one of the following ways (see item i) of clause 3):

- a) by the purchaser or his nominated representative, who shall inspect the wheels ordered and witness any of the tests; or
 - b) by delegation of the responsibility for the inspection by the purchaser to the manufacturer;
- or

c) within the application of a quality assurance system (see BS 5750 and the foreword).

8 Type and number of tests

8.1 Type of tests

The type and number of tests to be carried out for the specified delivery condition shall be in accordance with Table 8.

8.2 Test unit and subdivision into batches

The appropriate test unit for the respective test requirements shall be as given in Table 8.

For the purpose of testing, the wheels shall be grouped in batches. Each batch shall comprise wheels produced from the same cast and having undergone a similar heat treatment.

The condition of the wheels when submitted for testing shall be in accordance with Table 8.

The number of wheels per batch to be subjected to the tests and the number of tests per wheel shall be in accordance with Table 8.

8.3 Sampling and preparation of samples and test pieces

8.3.1 General

The wheels intended for testing, selected at random from the batch, shall be identified by indelible stamping. The person responsible for the inspection shall indicate on each of these wheels the area (segment) (see Figure 7) from which the test pieces are to be taken.

If a residual stress test is required, this test shall be carried out before cutting out the segment (see item l) of clause 3).

8.3.2 Product check analysis

When specified (see item n) of clause 3) one of the following samples shall be taken from one of the test wheels:

- a) at least 50 g of millings representing the average of a radial cross-section of the wheel; or
- b) in the case of spectrographic analysis, one sample from the tensile test piece in position (1) of Figure 7.

8.3.3 Tensile test

One test sample shall be taken from each test wheel at position (1) indicated in Figure 7 and a test piece prepared.

In the case of rim chilled wheels in heat treatment condition (T) one further tensile test sample shall be taken from position (2) indicated in Figure 7 and a further test piece prepared.

The test pieces shall be prepared in accordance with BS EN 10002-1.

NOTE The preferred test piece is one having a gauge length of at least 10 mm.

8.3.4 Impact test (Charpy U)

Three test samples shall be taken from the positions indicated in Figure 7. The marking of the impact test samples shall enable identification of the longitudinal surfaces which are parallel to the section A-A. The test pieces shall be prepared in accordance with BS EN 10045-1. The axis of the bottom of the notch shall be parallel to the section A-A in Figure 7.

8.3.5 Static imbalance test

The test shall be carried out on a finished wheel or, if requested by the purchaser, a finished wheel with an accurate but under-sized bore.

8.3.6 Hardness

8.3.6.1 Uniformity of rim hardness

When specified (see item k) of clause 3) the frequency of tests shall be as stated in Table 8. The Brinell hardness test shall be carried out on the plane face of the rim on the side opposite the flange. The indentation shall be situated on a circumference with a radius approximately 25 mm less than that of the running circle (see Figure 8). The test position shall be prepared by lightly grinding in order to remove any decarburization.

8.3.6.2 Hardness survey

The test piece shall consist of a slice comprising the complete radial section of the rim and web selected from the sample segment (see Figure 8). One of its faces shall be prepared in accordance with BS 240. The hardness indentations shall be situated on the three radial lines indicated in Figure 8 at distances from the tread of 5 mm and 35 mm. If the limit of tread-wear is less than 35 mm, however, the indentations shall be made at this limit instead of at the distance of 35 mm.

8.3.7 Ultrasonic test

When specified (see item j) of clause 3) the test shall be carried out on the wheel after heat treatment.

8.4 Surface condition

The manufacturer shall carry out surface condition checks to ensure that the $\overline{A_1}$ wheels $\overline{A_1}$ are in accordance with Table 6.

8.5 Dimensional checks

The manufacturer shall carry out dimensional checks to ensure that the $\overline{A_1}$ wheels $\overline{A_1}$ are in accordance with Table 4 and Table 5.

Table 8 — Type and number of tests

Requirements	Heat treatment condition on delivery	Status of test	Test unit and condition on test	Number of wheels per batch to be tested for batches of:		Number of tests per wheel
				Up to 250	Over 250	
Chemical analysis	All	m	c	1	1	1
Tensile test on the rim	All	m h	ch	1	2	1
Tensile test on the web	T	m h	ch	1	2	1
Impact test (KU)	N, T, E	m h	ch	1	2	3
Static balancing	N, T, E	o	w f	100 %	100 %	1
Uniformity of rim hardness	N, T, E	o h	ch	10 %	10 %	1
Hardness survey	T	m h	ch	1	1	1
Residual stresses	T	o h	ch	1	1	1
Ultrasonic flaw detection	All	o h	w	100 %	100 %	1
Appearance and dimensions	All	m	w f	100 %	100 %	1

Key

m signifies mandatory tests;

o signifies optional tests, i.e. tests which need only be carried out if specified in the order or its appended documents;

h signifies that the tests are not carried out before the specified heat treatment;

f signifies that the tests are carried out in the final delivery condition;

c signifies wheels from the same cast;

ch signifies wheels from the same cast and the same heat treatment batch;

w signifies that the wheel is the test unit.

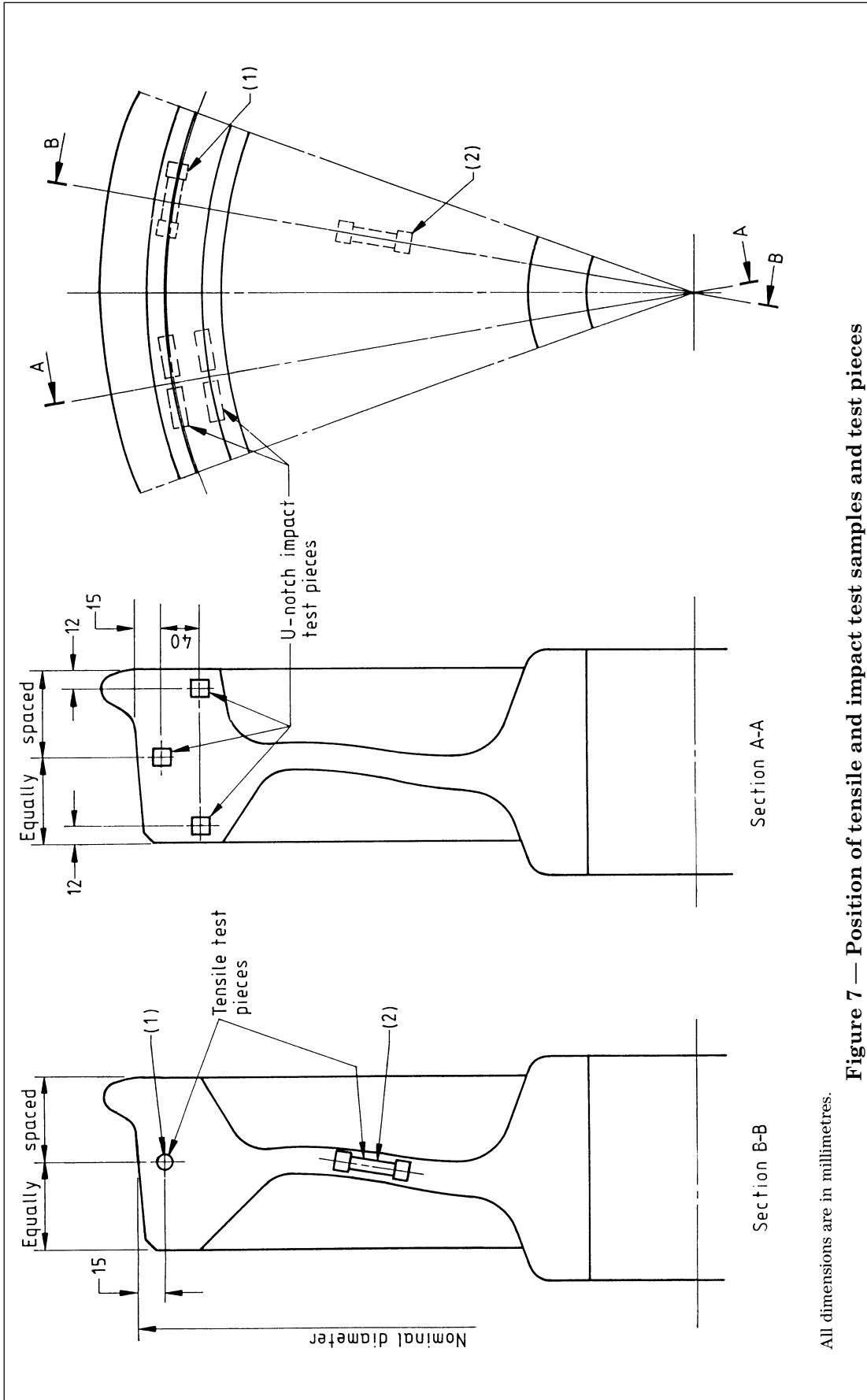

Figure 7 — Position of tensile and impact test samples and test pieces
 All dimensions are in millimetres.

9 Test methods

9.1 Chemical analysis

NOTE It is permissible to use any recognized method for the determination of cast analysis.

In cases of dispute the analysis shall be carried out in accordance with BS 6200.

9.2 Tensile test

The tensile test shall be carried out in accordance with BS EN 10002-1.

9.3 Impact test

The impact test shall be carried out in accordance with BS EN 10045-1.

9.4 Static balance

When specified, the residual imbalance of each wheel shall be checked by a procedure approved by the purchaser.

9.5 Brinell hardness

The Brinell hardness test shall be carried out in accordance with BS 240.

The hardness survey test shall be carried out with a ball of nominal diameter not more than 5 mm.

9.6 Assessment of residual stress (see item l) of clause 3)

Two marks 100 mm ± 0.1 mm apart shall be made in the centre of the thickness of the rim on the flat surface on the side opposite the flange; a radial cut from the top of the flange through to the bore shall then be made halfway between the two marks (see Figure 5).

The distance between the marks shall be measured again; it shall have been reduced by at least 1 mm.

9.7 Ultrasonic testing

The tests shall be carried out to a procedure agreed between the manufacturer and the purchaser (but see also 8.3.7).

9.8 Checking of surface condition

Machined surfaces shall be assessed for surface finish using the methods given in BS 1134-1 or by the use of comparison specimens (see BS 2634-1).

9.9 Checking of dimensions

The dimension checks shall be carried out using measuring instruments forming part of a measurement and calibration system in accordance with BS 5781.

10 Test results

10.1 Chemical composition

The cast composition shall be in accordance with the values given for the appropriate grade of steel in Table 1. If a product check analysis is required (see item n) of clause 3), the variations permitted in product analyses given in Table 2 shall apply.

10.2 Mechanical properties

The mechanical properties determined on test pieces prepared in accordance with 8.3.3 and 8.3.4 and tested in accordance with 9.2 and 9.3 shall be in accordance with the values given in Table 3 for the appropriate grade. Yield stress R_e and 0.2 % proof stress R_p shall be determined and recorded for information purposes.

10.3 Balance (mass distribution)

Unless otherwise specified, the maximum residual imbalance shall be in accordance with Table 7. Where no information on maximum speeds is available, the manufacturer shall use a maximum speed for stock of 80 km/h (see Table 7).

10.4 Uniformity of hardness

If requested in the enquiry and order (see item k) of clause 3), the Brinell hardness results obtained shall be in accordance with the ranges given in Table 3 appropriate to the ordered grade.

10.5 Depth of rim chilled zone (T designation wheels only)

The thickness of the treated zone, estimated from the results of the hardness survey tests (see 8.3.6 and 5.2) shall be not less than the total tread-wear which shall be specified on the drawing (see item b) of clause 3).

The purchaser shall have the right to specify the minimum hardness at the extreme of the wear depth.

The rim chilling shall not modify the characteristics of the web (see Table 3).

10.6 Residual stress (T designation wheels only)

NOTE One purpose of rim chilling is to produce favourable circumferential residual compressive stresses in the rim of the wheel.

The manufacturer shall demonstrate that the procedure used for such treatment results in an adequate magnitude of residual circumferential compressive stress. The method described in 9.6 shall be used.

10.7 Ultrasonic testing

The method and procedures for the ultrasonic testing and the acceptance standards shall be stated in the enquiry and order (see item j) of clause 3).

Unless otherwise specified, the following acceptance standard shall apply.

Wheels possessing no more than 10 defect signals in the rim for which the ratio of the amplitude of the defect signal or supplementary echo to that of the back-wall echo of an adjacent sound zone does not exceed 0.25 shall be accepted, provided that there is at least 15 mm between two adjacent defect signals.

10.8 Surface condition

The degree of finish of the machined surfaces shall be in accordance with Table 6 and measured by the use of comparison specimens. Where it is agreed that parts of wheels remain black, they shall blend smoothly into the machined portions.

NOTE The order or drawing may require wheels to be completely machined over the entire surface, including that of the boss.

Wheels shall be free from any surface markings indicative of rolled in laps or defects.

NOTE It is permissible for the Brinell hardness indentations to be left on the surface of the rim.

10.9 Dimensions

The dimensions shall be as specified on the drawing and the tolerances shall be in accordance with Table 4, Table 5 and Table 6.

10.10 Re-tests

If any product check analysis sample fails to comply with 10.1 two further samples from the same wheel may be taken, both of which shall comply with 10.1.

If the tensile test piece fails to comply with 10.2, twice the original number of test pieces shall be selected for retesting, at least one of which shall be taken from the wheel from which the original test sample was taken, unless that item has been withdrawn by the manufacturer. The mechanical properties obtained from the test pieces prepared from the further test samples shall comply with 10.2. Should any of the retests fail, the material represented shall be deemed not to comply with this Part of BS 5892.

If the average of three impact values is lower than the specified value, or if any one value is lower than 70 % of this specified value, three additional test pieces shall be taken from the same sample and tested. The average value of the six tests shall be not less than the specified value. Not more than two of the individual values shall be lower than the specified value and not more than one shall be lower than 70 % of this value.

If any hardness test results fall below the minimum value specified, when 10 % of wheels are being tested in accordance with Table 8, hardness tests shall be taken on 100 % of the batch.

In the case of wheels supplied in the heat treated condition (N, T or E) the manufacturer shall have the right to re-heat treat the batch and to re-submit it for testing.

11 Conclusion of inspection

After final inspection, all accepted wheels shall be stamped by the purchaser's inspector or the delegated authority to signify conformance.

12 Certification

If required (see item m) of clause 3), the manufacturer shall supply a certificate of conformance to BS 5892-3 according to the purchaser's requirements in accordance with clause 3).

Records of all tests shall be traceable to the cast and heat treatment batch (see 8.3) and shall be available for examination.

13 Protection in transport

13.1 Protection against corrosion

After inspection, and before storage or despatch, all finished machined parts shall be protected against corrosion by a method specified by the purchaser.

NOTE Applied protective coatings are only of limited life especially under conditions of sea transport or in geographical regions of high humidity. Therefore, the delivered wheels should be inspected, immediately on arrival at their destination, to see whether a renewal of the protection is necessary.

13.2 Protection against mechanical damage

The finished machined portions, especially the bores of the wheels, shall be provided, before despatch, with protection against mechanical damage. The method for protection shall be specified by the purchaser.

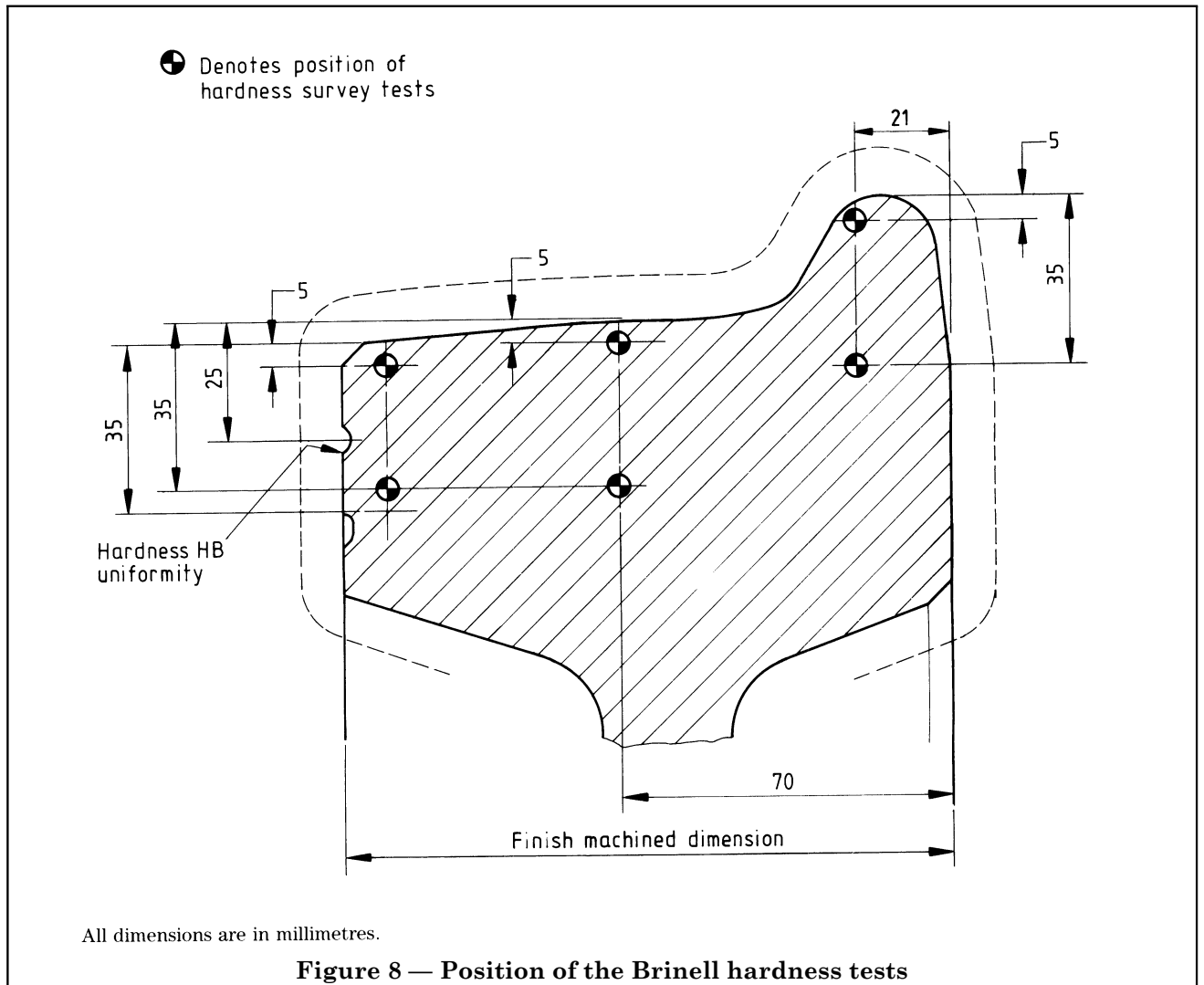

Publications referred to

- BS 240, *Method for Brinell hardness test and for verification of Brinell hardness testing machines.*
- BS 308, *Engineering drawing practice.*
- BS 308-3, *Recommendations for geometrical tolerancing.*
- BS 1134, *Assessment of surface texture.*
- BS 1134-1, *Methods and instrumentation.*
- BS 2634, *Specification for roughness comparison systems.*
- BS 2634-1, *Specification for turned, ground, bored, milled, shaped and planed specimens.*
- BS 4490, *Methods for micrographic determination of the grain size of steel.*
- BS 5750, *Quality systems.*
- BS 5750-1, *Specification for design/development, production, installation and servicing.*
- BS 5750-2, *Specification for production and installation.*
- BS 5750-3, *Specification for final inspection and test.*
- BS 5781, *Measurement and calibration systems.*
- BS 5892, *Railway rolling stock material (metric).*
- BS 5892-6, *Specification for wheelsets for traction and trailing stock.*
- BS 6200, *Sampling and analysis of iron, steel and other ferrous metals.*
- BS EN 10002, *Tensile testing of metallic materials.*
- BS EN 10002-1, *Method of test at ambient temperature.*
- BS EN 10045, *Charpy impact test on metallic materials.*
- BS EN 10045-1, *Test method (V- and U-notches).*
- Ⓐ) BS EN 13103, *Railway applications — Wheelsets and bogies — Non-powered axles — Design method.*
- BS EN 13104, *Railway applications — Wheelsets and bogies — Powered axles — Design method.*
- BS EN 13261, *Railway applications — Wheelsets and bogies — Axles — Product requirements.* Ⓐ)
- ISO 1005-6:1982, *Railway rolling stock material — Part 6: Solid wheels for tractive and trailing stock — Quality requirements.*
- UIC 812-3, *Technical specification for the supply of solid wheels in rolled non-alloy steel for tractive and trailing stock²⁾.*

²⁾ Referred to in the foreword only.

BSI — British Standards Institution

BSI is the independent national body responsible for preparing British Standards. It presents the UK view on standards in Europe and at the international level. It is incorporated by Royal Charter.

Revisions

British Standards are updated by amendment or revision. Users of British Standards should make sure that they possess the latest amendments or editions.

It is the constant aim of BSI to improve the quality of our products and services. We would be grateful if anyone finding an inaccuracy or ambiguity while using this British Standard would inform the Secretary of the technical committee responsible, the identity of which can be found on the inside front cover.
Tel: +44 (0)20 8996 9000. Fax: +44 (0)20 8996 7400.

BSI offers members an individual updating service called PLUS which ensures that subscribers automatically receive the latest editions of standards.

Buying standards

Orders for all BSI, international and foreign standards publications should be addressed to Customer Services. Tel: +44 (0)20 8996 9001.
Fax: +44 (0)20 8996 7001. Email: orders@bsi-global.com. Standards are also available from the BSI website at <http://www.bsi-global.com>.

In response to orders for international standards, it is BSI policy to supply the BSI implementation of those that have been published as British Standards, unless otherwise requested.

Information on standards

BSI provides a wide range of information on national, European and international standards through its Library and its Technical Help to Exporters Service. Various BSI electronic information services are also available which give details on all its products and services. Contact the Information Centre.
Tel: +44 (0)20 8996 7111. Fax: +44 (0)20 8996 7048. Email: info@bsi-global.com.

Subscribing members of BSI are kept up to date with standards developments and receive substantial discounts on the purchase price of standards. For details of these and other benefits contact Membership Administration.
Tel: +44 (0)20 8996 7002. Fax: +44 (0)20 8996 7001.
Email: membership@bsi-global.com.

Information regarding online access to British Standards via British Standards Online can be found at <http://www.bsi-global.com/bsonline>.

Further information about BSI is available on the BSI website at <http://www.bsi-global.com>.

Copyright

Copyright subsists in all BSI publications. BSI also holds the copyright, in the UK, of the publications of the international standardization bodies. Except as permitted under the Copyright, Designs and Patents Act 1988 no extract may be reproduced, stored in a retrieval system or transmitted in any form or by any means – electronic, photocopying, recording or otherwise – without prior written permission from BSI.

This does not preclude the free use, in the course of implementing the standard, of necessary details such as symbols, and size, type or grade designations. If these details are to be used for any other purpose than implementation then the prior written permission of BSI must be obtained.

Details and advice can be obtained from the Copyright & Licensing Manager.
Tel: +44 (0)20 8996 7070. Fax: +44 (0)20 8996 7553.
Email: copyright@bsi-global.com.