

BRITISH STANDARD

**Methods of test for
assessment of the
ignitability of
upholstered seating by
smouldering and flaming
ignition sources**

ICS 13.220.40; 97.140

BSi
British Standards

Publishing and copyright information

The BSI copyright notice displayed in this document indicates when the document was last issued.

© BSI 2006

ISBN 0 580 47926 9

The following BSI references relate to the work on this standard:

Committee reference FW/6

Draft for comment DC05/30057625

Publication history

First published in parts:

Part 1 November 1979 and Part 2 August 1982 (still current)

Second edition, as BS 5852, December 1990

Third edition March 2006

Amendments issued since publication

Amd. no.	Date	Text affected
-----------------	-------------	----------------------

Contents

Foreword *iii*

0	Introduction	<i>1</i>
1	Scope	<i>3</i>
2	Normative references	<i>4</i>
3	Terms and definitions	<i>4</i>
4	Criteria of ignition	<i>4</i>
5	Principle	<i>10</i>
6	Health and safety of operators	<i>10</i>
7	Apparatus	<i>11</i>
8	Smouldering ignition source 0 – cigarette	<i>14</i>
9	Flaming ignition sources 1 to 7 – butane gas flames and flaming wooden cribs	<i>14</i>
10	Atmosphere for conditioning and testing	<i>20</i>
11	Methods of test for the ignitability of upholstery composites	<i>20</i>
12	Methods of test for the ignitability of complete items of furniture	<i>26</i>
13	Final examination	<i>35</i>
14	Test report	<i>35</i>

Annexes

Annex A (informative)	Guidance for test operators	<i>37</i>
Annex B (informative)	Guidance for designers and specifiers	<i>38</i>
Annex C (informative)	Gas flow control	<i>41</i>
Annex D (informative)	Suggested methods of crib construction	<i>41</i>
Annex E (normative)	Water soaking and drying procedure	<i>42</i>
Annex F (informative)	Example of test report layout	<i>44</i>

Bibliography *45*

List of figures

Figure 1 – Flow diagram for detection of ignition using source 0 (cigarette)	<i>5</i>
Figure 2 – Flow diagram for detection of ignition using gas flame sources 1, 2 and 3	<i>6</i>
Figure 3 – Flow diagram for detection of ignition using wooden crib sources 4, 5, 6 and 7	<i>7</i>
Figure 4 – Test rig detail	<i>12</i>
Figure 5 – Test rig assembly	<i>13</i>
Figure 6 – Crib ignition source 4	<i>17</i>
Figure 7 – Crib ignition source 5	<i>17</i>
Figure 8 – Crib ignition source 6	<i>18</i>
Figure 9 – Crib ignition source 7	<i>19</i>
Figure 10 – Details of test specimens for covers and interliners for use with the test rig	<i>22</i>
Figure 11 – Model position for ignition source in seating area	<i>30</i>
Figure 12 – Alternative positions for ignition source in seating area	<i>31</i>
Figure 13 – Additional model positions of ignition sources for tip-up seats	<i>31</i>
Figure 14 – Model position for ignition source at floor level	<i>32</i>
Figure F.1 – Example of test report layout	<i>44</i>

List of tables

Table 1 – Parameters of butane gas ignition sources 1, 2 and 3 15

Table 2 – Parameters of crib ignition sources 4 and 5 16

Table 3 – Parameters of crib ignition sources 6 and 7 16

Table 4 – Minimum distance of test specimen above top of ignition source 29

Table A.1 – Suggested grading of sticks on mass/unit length basis 37

Summary of pages

This document comprises a front cover, an inside front cover, pages i to iv, pages 1 to 45 and a back cover.

Foreword

Publishing information

This British Standard was published by BSI and came into effect on 31 March 2006. It was prepared by Technical Committee FW/6, *Flammability performance and fire testing*. A list of organizations represented on this committee can be obtained on request to its secretary.

Supersession

This British Standard supersedes BS 5852:1990, which is withdrawn.

However, since the Furniture and Furnishings (Fire) (Safety) Regulations 1988 [1] refer to the earlier editions of the standard, neither BS 5852-1:1979 nor BS 5852-2:1982 can be withdrawn at the present time.

Relationship with other publications

This British Standard extends the range of ignition sources provided by BS EN 1021-1 and BS EN 1021-2.

Information about this document

This is a full revision of the standard. The principal changes are to update references, to bring the standard into line with BS 6807 and BS EN 1021, and to incorporate the existing amendments. There are no significant technical changes from the previous edition.

The range of methods specified enables an assessment to be made of the ignitability of upholstered furniture assemblies. These assemblies may be test composites as described in Clause 11, which may be subjected to any one of a range of flaming ignition sources, or complete items of furniture as described in Clause 12, which may be subjected to a smouldering cigarette or any one of a range of flaming ignition sources.

Ignition tests are not highly repeatable and duplicate results are required for the test rigs described in Clause 11 to achieve a full non-ignition test result. It is recognized that it will not always be possible to carry out duplicate tests on the selected sites when testing actual furniture in accordance with Clause 12 and in these cases, it is necessary to achieve an indicative non-ignition result on all of the test sites.

NOTE The tests described in Clause 12 may also be applied to non-upholstered seating.

It cannot be assumed that protection against large flaming sources will automatically give protection against smouldering ignition. It is therefore necessary to submit test specimens to both smouldering and flaming ignition tests.

Hazard warnings

WARNING. These tests only relate to the ignitability of the specimens as supplied under the particular conditions of test and do not take into consideration the effects of ageing, washing, soiling, etc. that might be encountered during the life of the product. The tests cannot give a full assessment of fire properties in all situations.

Measures taken to reduce the ignitability of an assembly can adversely affect other fire properties such as smoke and toxic gas evolution.

WARNING. This British Standard calls for the use of substances and/or procedures that can be injurious to health if adequate precautions are not taken. It refers only to technical suitability and does not absolve the user from legal obligations relating to health and safety at any stage.

CAUTION. For some upholstery tests, all outer covers might be required to be subjected to a water soaking and drying procedure prior to conditioning as described in **10.1.2**.

Guidance for test operators is given in Annex A. It is important that the details given in the annex are studied before testing is carried out.

Attention is drawn to BS 7176, which applies the tests described in this standard to upholstered furniture in various hazard areas.

Presentational conventions

The provisions of this standard are presented in roman (i.e. upright) type. Its methods are expressed either as a set of instructions or in sentences in which the principal auxiliary verb is “shall”.

Commentary, explanation and general informative material is presented in smaller italic type, and does not constitute a normative element.

Contractual and legal considerations

This publication does not purport to include all the necessary provisions of a contract. Users are responsible for its correct application.

Compliance with a British Standard cannot confer immunity from legal obligations.

Attention is drawn to the following regulations:

- Furniture and Furnishings (Fire) (Safety) Regulations 1988 [1];
- Furniture and Furnishings (Fire) (Safety) (Amendment) Regulations 1989 [2];
- Furniture and Furnishings (Fire) (Safety) (Amendment) Regulations 1993 [3];
- Control of Substances Hazardous to Health Regulations 2002 [4].

0 Introduction

0.1 Objective

The objective of this standard is to measure the ignitability of upholstered furniture composites and/or complete pieces of furniture.

No method using realistic shapes yet exists for measuring levels of ignition on a continuous scale for these composites and consequently the methods used in this standard provide ignition/non-ignition results at a number of fixed levels. One smouldering source together with a range of flaming sources, whose energy rises by a factor of approximately two at each step, are used. Thus a level representing the boundary of ignition can be associated with a particular construction. Although the levels do not form a continuous series, they do provide more information than an arbitrary single go/no go result and so allow smaller variations in ignitability to be related to actual hazards.

This assessment is intended eventually to form part of a much fuller fire hazard assessment when work now in progress on fire development and smoke and toxic hazards in fire is completed.

0.2 Background

0.2.1 An assessment of the results of various research projects, carried out to investigate the fire properties of furniture, clearly indicates that tests carried out on component materials in isolation could not give a true indication of their behaviour when combined with other component materials in a piece of furniture. Therefore, to evaluate the ignitability of any item of seating, having due regard to the effects of interactions between materials and of design, it is necessary to test the complete finished item of furniture. Such testing procedures are contained in Clause 12. However, there is a very wide range of designs and materials employed, so tests have been developed to assess upholstery materials combined together to give information regarding the ignitability properties of assemblies that might be used in a number of different circumstances. Model tests (see Clause 11) of this kind can eliminate the least useful combinations from further consideration in the design process.

0.2.2 The form of the test rig was decided after observation of many ignition experiments had shown that the position at which accidentally dropped cigarettes are most likely to cause ignition is in any angle between adjacent surfaces, whereas accidentally dropped flaming materials have worse effects where vertical and horizontal surfaces are involved. These situations have been modelled even though in practice the assembly might be used only on a single surface.

The results, therefore, provide a measure of the ignitability of a combination of cover and filling which is equally valid for the different designs of furniture in which the combination might be used and for the different applications in that furniture.

The design of the furniture is an important additional consideration which can enhance or detract from the flammability performance of the item. For example, there might be pleats or folds in the primary cover; loops or crevices created by braids, piping, zips, ruches or other trimmings; traps and chimneys created by cushions; the presence of wing arms or other overhangs; or an exposed area beneath the seat which is vulnerable to ignition from floor level. In such cases stylized representation is not easily possible, nor practical. For these reasons tests on actual items are included in this standard.

Ideally these tests should be the final stage of the sifting process for ignitability, when the most useful candidate constructions are checked to ensure that the extra complexities of shape and added materials do not render the predictions from rig tests misleading.

0.2.3 The following ignition sources are specified.

- a) *Smouldering*. This consists of a single cigarette since it is unrealistic to use multiple cigarettes at a single position and the “fail-safe” magnitude is a full cigarette rather than smaller parts.
- b) *Flaming*. This range consists of butane flames and burning wooden cribs which form a sequence of increasing thermal output from that approximating to the burning of a small flame to that approximating to the burning of four double sheets of a full-size newspaper. It has to be emphasized that the cribs are not intended to reproduce burning newspapers in all respects and the thermal output comparisons are given for guidance only. The cribs have been designed to give an additional weight loading (greater than that obtained with newspaper) on the upholstery composite. This is important in order to include situations that might occur in practice and to ensure that the test method errs on the side of safety with combinations prone to failure under load. Examples of these situations might be high localized cover tension induced by deep-buttoned upholstery, or the presence of heavy books close to the ignition source.

These sources are also static and apply their energy over a restricted area. Some real life sources spread flames gradually over a larger area of the composite. The latter type of behaviour is different from, and is not modelled by, the larger ignition sources of equivalent thermal energy defined in this standard.

0.2.4 The scenarios modelled by these tests do not include deliberate arson and/or vandalism, though the tests include the application of reasonably large sources to undamaged furniture. The larger sources are intended to cover situations where a higher degree of carelessness is more probable or for locations where a higher level of resistance to secondary ignition is paramount. If arson is an important part of the in-use situation then other test methods attempting to reproduce the ingenuity of the fire-raiser should be carried out.

0.3 Method of use

The test methods in Clause **11** measure the ignitability of the overall composite of materials, i.e. cover(s), filling materials, etc. as constructed on the test specimen. The results cannot be stated as being applicable to the general behaviour of any individual component but only to the total composite tested.

The ignitability of an assembly may be determined by applying the sources in the order of source 2 to source 7, but for many specification purposes a test(s) involving one, or a limited number of selected sources, might be necessary.

The ignitability of an assembly may be determined by applying source 0 and source 1 which are defined in BS EN 1021-1:1994 and BS EN 1021-2:1994 respectively.

The ignitability of a complete item of furniture may be determined by applying the sources in the order of source 0 to source 7, but for many specification purposes a test(s) involving one, or a limited number of selected sources, might be necessary.

In the case of the tests described in Clause **12** the results will be applicable only to the finished item of furniture tested.

1 Scope

This British Standard describes methods for assessing the ignitability of single material combinations, e.g. covers and fillings used in upholstered seating, or complete items of seating, when subjected either to a smouldering cigarette or to flaming ignition sources of thermal output ranging from that of a burning match to that approximating to the burning of four double sheets of full-size newspaper, as might be applied accidentally to any item of furniture.

NOTE 1 It does not necessarily cover ignition caused by deliberate acts of vandalism with arson.

The following methods are described:

- a) upholstered seating composites tested with flaming ignition sources (sources 2 to 7) (Clause **11**);
- b) complete items of upholstered furniture tested with smouldering or flaming ignition sources (sources 0 to 7) (Clause **12**).

NOTE 2 Possible ways in which the standard can be used either to indicate the potential ignitability of components in conjunction with other specified materials or where more specific information is required about design features are given in Annex B.

2 Normative references

The following referenced documents are indispensable for the application of this document. For dated references, only the edition cited applies. For undated references, the latest edition of the referenced document (including any amendments) applies.

BS EN 1021-1 *Furniture – Assessment of the ignitability of upholstered furniture – Part 1: Ignition source: smouldering cigarette*

BS EN 1021-2 *Furniture – Assessment of the ignitability of upholstered furniture – Part 2: Ignition source: match flame equivalent*

3 Terms and definitions

For the purposes of this British Standard, the following terms and definitions apply.

- 3.1 ignition source**
source of energy which is used to ignite combustible materials or products
- 3.2 smouldering**
combustion of a material with or without the emission of light and generally evidenced by smoke and an increase in temperature but without a flame
- 3.3 progressive smouldering**
smouldering that is self-propagating, i.e. independent of the ignition source
- 3.4 flaming**
undergoing combustion in the gaseous phase with the emission of light and heat
- 3.5 flammability**
ability of a material or product to burn with a flame under specified test conditions
- 3.6 ignitability**
measure of the ease with which a material, product or component can be ignited so as to flame or progressively smoulder
- 3.7 test zone**
component and/or design feature of the test specimen which is nominated for localized testing

4 Criteria of ignition

NOTE 1 Ignition criteria are given for progressive smouldering and for flaming. These are both critical but are different modes of ignition and should be assessed separately.

NOTE 2 A flow diagram illustrating a systematic method for the detection of ignition throughout a test sequence for each type of ignition source is given in Figure 1, Figure 2 and Figure 3.

Figure 1 Flow diagram for detection of ignition using source 0 (cigarette)

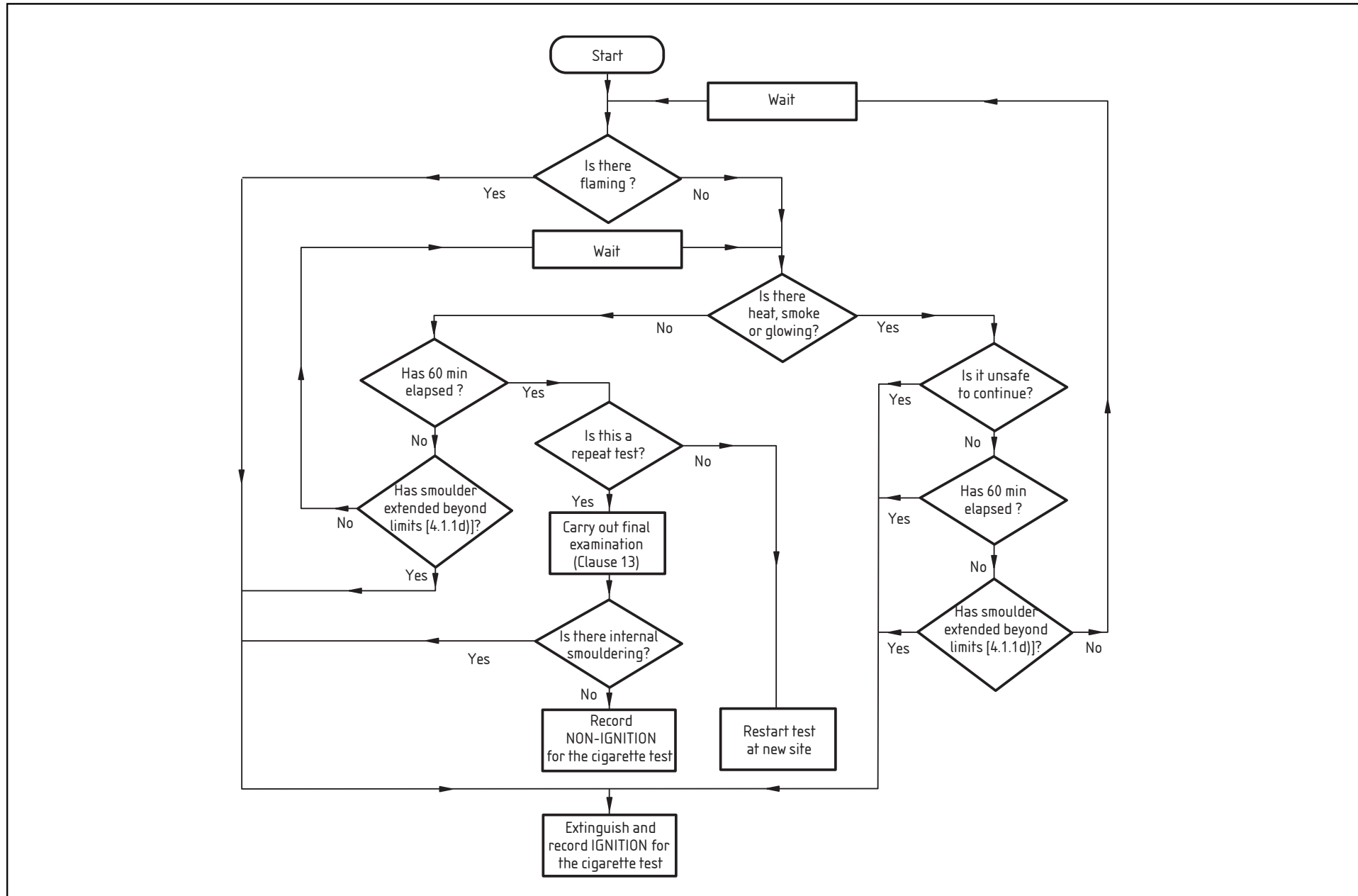

Figure 2 Flow diagram for detection of ignition using gas flame sources 1, 2 and 3

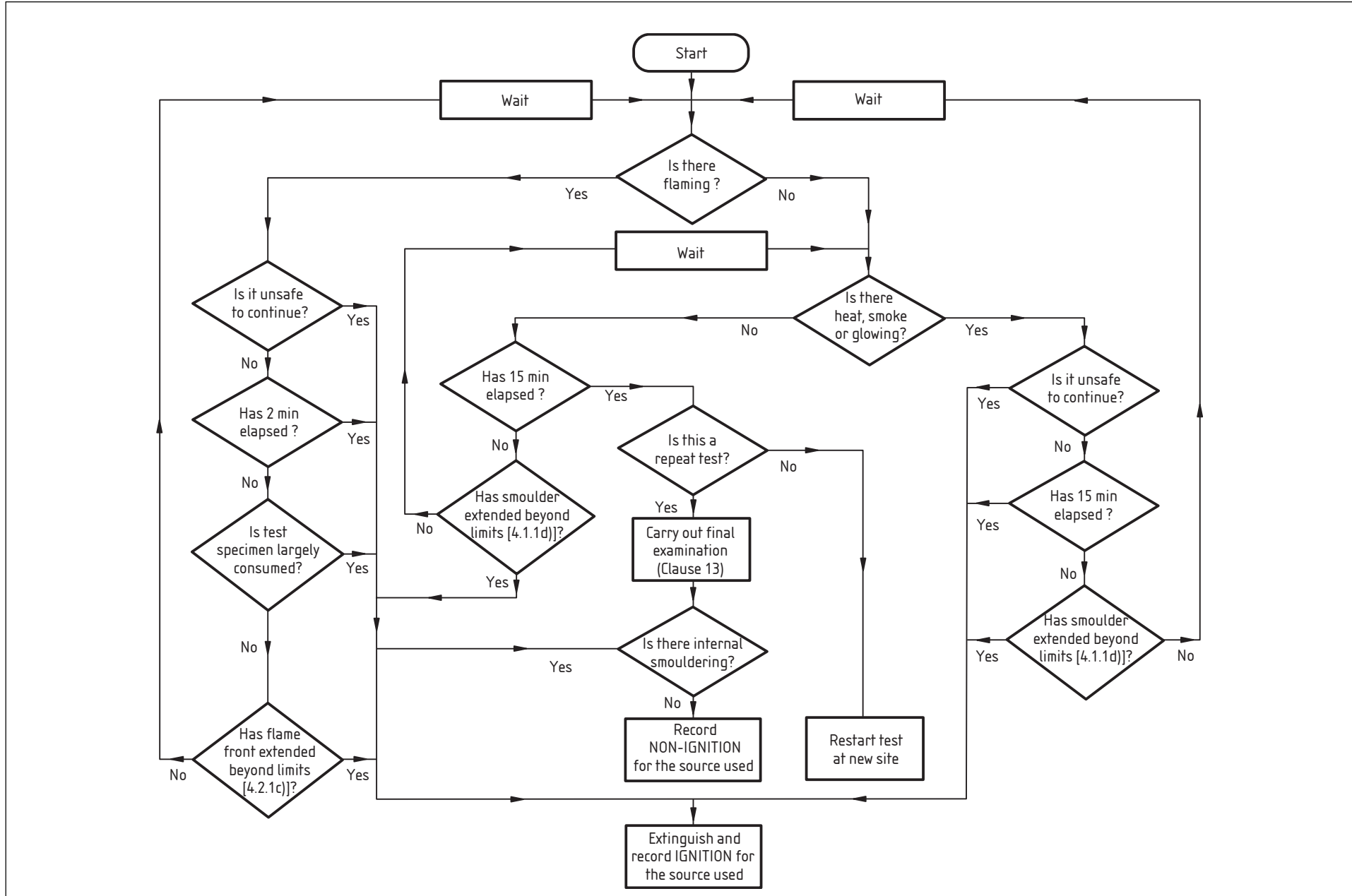
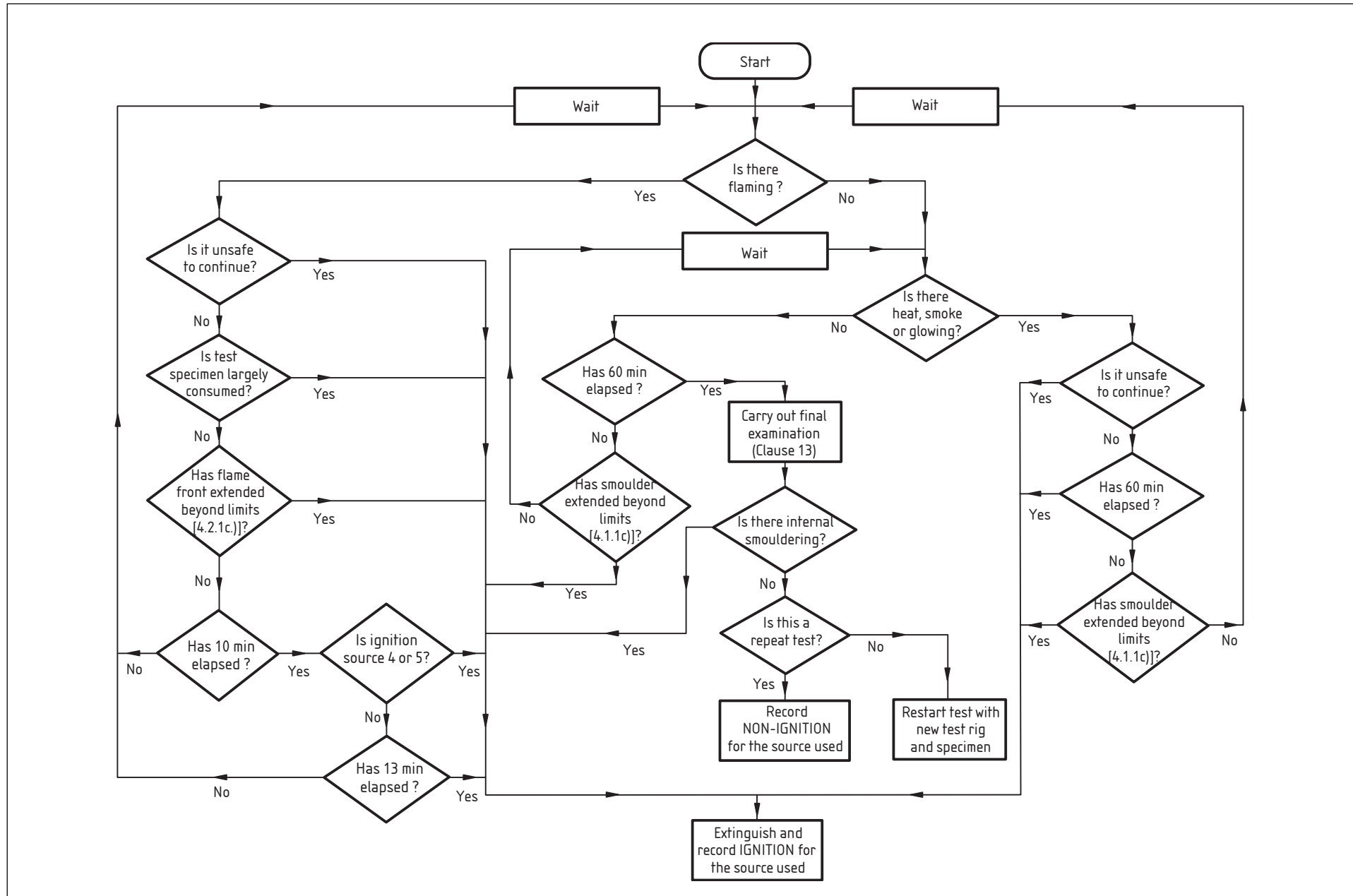

Figure 3 Flow diagram for detection of ignition using wooden crib sources 4, 5, 6 and 7



4.1 Progressive smouldering ignition

4.1.1 Upholstery composites

For the purposes of testing the ignitability of upholstery composites (see Clause 11), all the following types of behaviour shall be deemed to be progressive smouldering ignition (but see also Clause 13):

NOTE In practice it has been found that there is usually a clear distinction between materials that smoulder and char under the influence of the ignition source but that do not propagate further (non-progressive) and those where smouldering develops in extent and spreads (progressive).

- a) any test specimen that displays escalating smouldering combustion behaviour so that it is unsafe to continue the test and forcible extinction is required;
- b) for the smouldering cigarette source 0: any test specimen that produces externally detectable amounts of smoke, heat or glowing within the period from the extinction of the source until 60 min after placement of the source;
- c) for all flaming ignition sources: any test specimen that smoulders until it is essentially consumed or that smoulders to the extremities of the specimen, i.e. to either side or to/through the full thickness of the specimen, within the duration of the test;
- d) for flaming ignition sources 2 and 3: any test specimen that produces externally detectable amounts of smoke, heat or glowing 15 min after removal of the burner tube;
- e) for flaming ignition sources 4, 5, 6 and 7: any test specimen that produces externally detectable amounts of smoke, heat or glowing 60 min after ignition of the crib;
- f) any test specimen that, on final examination (see Clause 13), shows evidence of charring within the filling (other than discoloration) more than 100 mm in any direction, apart from upwards, from the nearest part of the original position of the source.

4.1.2 Complete items of furniture

For the purposes of testing the ignitability of complete items of furniture (see Clause 12), all the following types of behaviour shall be deemed to be progressive smouldering ignition (but see also Clause 13):

- a) those given in 4.1.1 items a), b), d), e) and f);
- b) for all flaming ignition sources: any test specimen that smoulders until it is essentially consumed or that smoulders to the extremities of the specimen, i.e. to either side of the specimen or to the extremities of the upholstered test zone, within the duration of the test.

4.2 Flaming ignition

4.2.1 Upholstery composites

For the purposes of testing the ignitability of upholstery composites (see Clause 11), all the following types of behaviour shall be deemed to be flaming ignition:

- a) any test specimen that displays escalating flaming combustion behaviour so that it is unsafe to continue the test and forcible extinction is required;
- b) any test specimen that burns until it is essentially consumed within the test duration;
- c) any test specimen on which any flame front reaches the extremities of the specimen other than the top of the vertical part of the test specimen, or passes through the full thickness of the specimen within the duration of the test (but see Note 1);

NOTE 1 It is recommended that composites which fail criterion c), e.g. because the full thickness is penetrated by molten material rather than by flames, are tested as a complete item of furniture (see Clause 12).

- d) for flaming ignition sources 2 and 3: any test specimen that continues to flame for more than 120 s after removal of the burner tube or in which the flame front spreads past a vertical line 100 mm from the tip of the burner tube;
- e) for flaming ignition sources 4 and 5: any test specimen that continues to flame for more than 10 min after ignition of the crib;
- f) for flaming ignition sources 6 and 7: any test specimen that continues to flame for more than 13 min after ignition of the crib;

NOTE 2 The times quoted in items e) and f) are essentially 2 min greater than the upper 95% probable extinction times of wooden cribs determined by interlaboratory testing.

- g) for all sources: any test specimen from which flaming debris causes an isolated floor fire that continues to flame for longer than the time given in d), e) or f).

4.2.2 Complete items of furniture

For the purposes of testing the ignitability of complete items of furniture (see Clause 12), all the following types of behaviour shall be deemed to be progressive smouldering ignition:

- a) those given in 4.2.1 items a), b), d), e), f) and g), but including source 1 for item 4.2.1d);
- b) any test specimen on which any flame front reaches the extremities of the specimen other than the top of the vertical part of the test specimen, within the duration of the test;
- c) for source 0 (cigarette): the occurrence of any visible flaming within 60 min of placement of the cigarette.

5 Principle

A test specimen is subjected to a series of ignition sources.

NOTE The series is designed to represent a range of actual intensities that might be accidentally encountered in various end-use environments.

In Clause 11 the test rig stylizes the critical geometry of vertical/horizontal junctions typically found in furniture, but tests a single cover/filling combination. In Clause 12 the test specimen consists of a complete item of furniture.

6 Health and safety of operators

WARNING. This British Standard calls for the use of substances and/or procedures that can be injurious to health if adequate precautions are not taken. It refers only to technical suitability and does not absolve the user from legal obligations relating to health and safety at any stage.

NOTE 1 Suitable precautions might include the provision of breathing apparatus and protective clothing.

NOTE 2 Attention is drawn to the Health and Safety at Work etc. Act 1974 [5] in respect of safety precautions.

6.1 Test enclosure

The tests shall be conducted in a suitable fume cupboard or purpose-built room so that individuals are not exposed to fumes (see 7.4).

6.2 Extinguishers

Readily accessible means of extinguishing the test specimens shall be provided. For the purposes of testing the ignitability of complete items of furniture (Clause 12), the extinguishing system shall be of sufficient capacity to deal with a fully developed fire.

NOTE 1 For preference, water should be provided for smouldering fires and a fire extinguisher for flaming fires. Carbon dioxide extinguishers are not suitable for extinguishing smouldering test specimens.

NOTE 2 Extinction of test specimens can be difficult and care should be taken that they are only disposed of when completely inert. It might be necessary to immerse smouldering specimens in water, or place them in a sealed non-combustible enclosure. To ensure complete safety other suitable steps might have to be taken.

7 Apparatus

7.1 Test rig (Clause 11 only), consisting of two rectangular frames hinged together and capable of being locked in position. The frame members shall have holes for the hinge rod and single pin/bolts with clearances such that, when in position, the movement between the vertical and horizontal components of the undressed rig does not cause the angle to move outside the range of $(90 \pm 2.5)^\circ$. The test rig shall be as shown in Figure 4.

The frames shall securely hold the expanded steel platforms.

NOTE 1 A standard edging section may be used around the expanded steel to give protection and greater rigidity.

NOTE 2 The size of the mesh of the expanded steel is not critical, but a mesh size across the diagonals of approximately 28 mm \times 6 mm has been found to be suitable. The expanded metal might bow slightly during test, but this has not been found to affect the result. However, certain performance specifications and upholstered furniture regulations might require a particular mesh size.

For the test rig illustrated in Figure 5, the internal width and height of the vertical frame shall be (450 ± 2) mm and the internal width and depth of the horizontal base frame shall be (450 ± 2) mm \times (300 ± 2) mm.

The frames shall be lockable through each of the pairs of members forming the back legs, as shown in Figure 4 and Figure 5, using either two bolts, or a single pin at least 500 mm long.

NOTE 3 It is convenient if the 10 mm hinge rod and single pin are "T" or "L" shaped and have a tapered end.

All parts of the test rig shall be of steel.

NOTE 4 Guidance on cleaning of the test rig is given in Annex A.

7.2 Stop clock, accurate to 1 s and capable of measuring at least 1 h.

7.3 Ignition sources as described in 11.3 and 12.4.

7.4 Test enclosure, comprising either a room with a volume greater than 20 m³ (which contains adequate oxygen for testing), or a smaller enclosure with a through-flow of air, equipped with inlet and extraction systems. Air flow rates shall be no greater than 0.2 m/s in the locality of the test specimen position.

NOTE These limits provide adequate oxygen without disturbing the burning behaviour.

The atmosphere within the enclosure during the test shall have a temperature of between 10 °C and 30 °C and a relative humidity of between 15% and 80%. A means of extracting smoke and toxic gases shall be provided for all such enclosures.

For the purposes of testing the ignitability of complete items of furniture (Clause 12), it shall be possible to position the test specimen such that the test zone (see 12.3) is not less than 0.5 m from the nearest enclosure wall.

7.5 Propan-2-ol (for ignition sources 4, 5, 6 and 7 only).

7.6 Graduated glass syringe or other suitable measuring instrument, capable of measuring (1.4 ± 0.1) ml of propan-2-ol.

Figure 4 Test rig detail

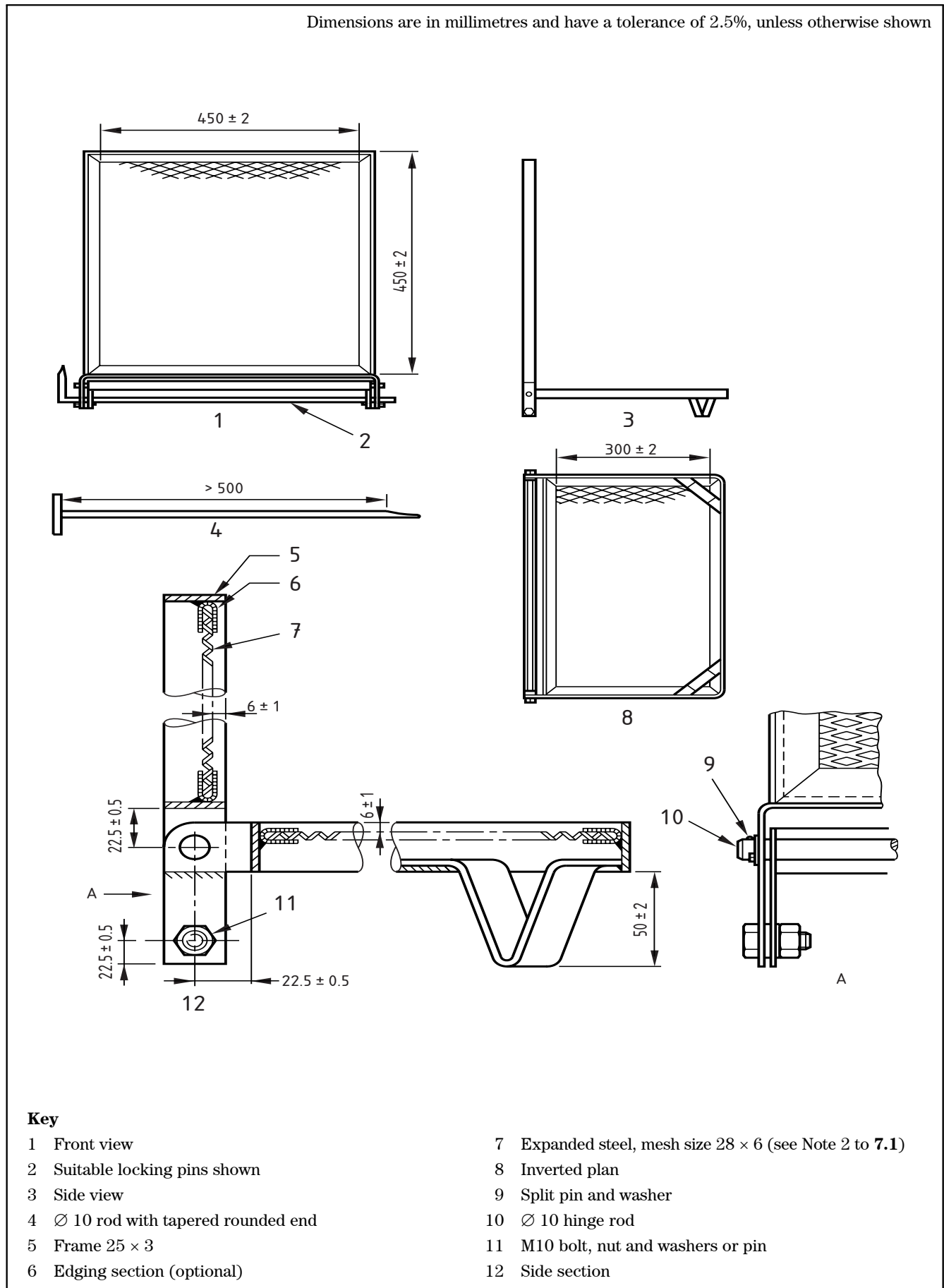
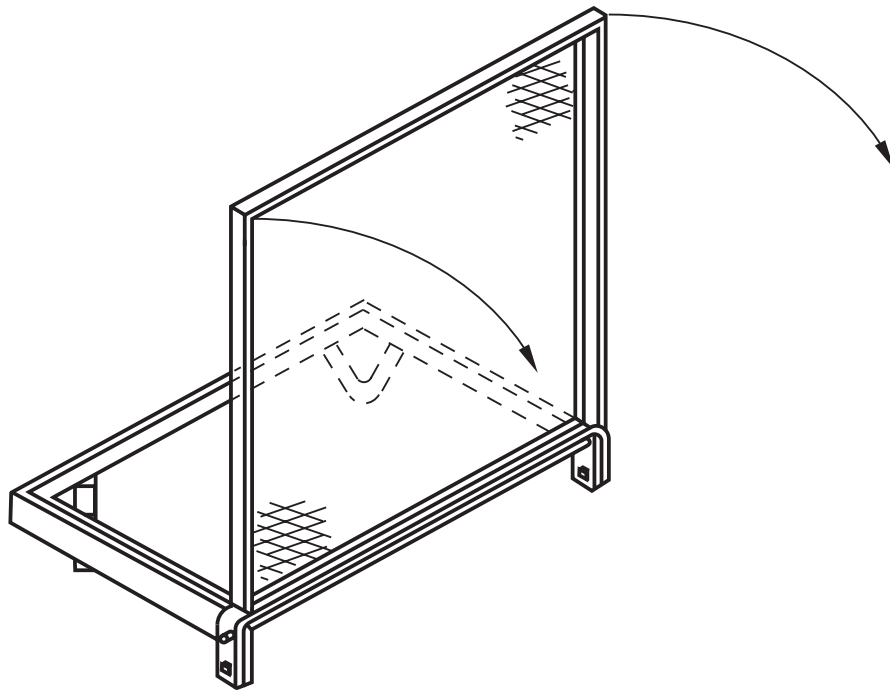
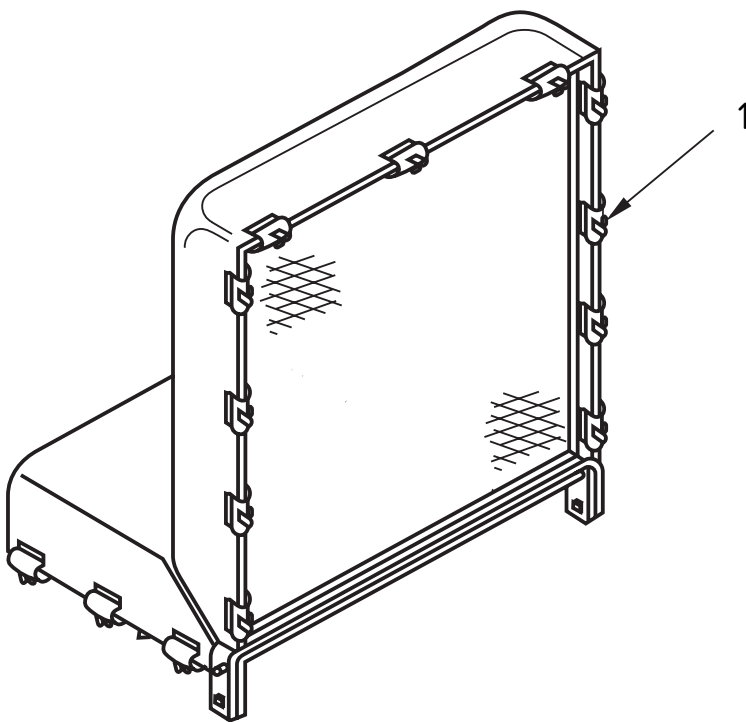

Figure 5 Test rig assembly



a) Test rig



b) Test rig with cover and fillings

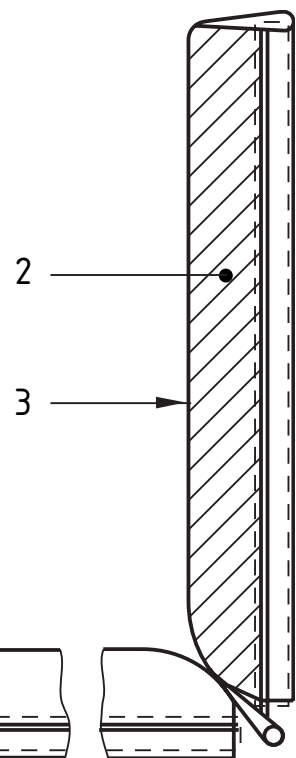

c) Vertical section

Key

- 1 Clips
- 2 Filling
- 3 Cover

8 Smouldering ignition source 0 – cigarette

NOTE In normal use the smouldering ignition source most likely to be encountered by furniture is a smouldering cigarette. An untipped standard-sized cigarette has been selected as representative of the most severe of the range of cigarettes on sale. This source is designated ignition source 0.

The ignition source shall be as specified in BS EN 1021-1.

9 Flaming ignition sources 1 to 7 – butane gas flames and flaming wooden cribs

9.1 General

A range of seven flaming ignition sources is provided, numbered in ascending order of severity from ignition source 1 to ignition source 7, approximating to the burning of four double sheets of a full-size newspaper.

9.2 Butane gas flame, ignition sources 1, 2 and 3

A burner tube consisting of a length of stainless steel tube, (8.0 ± 0.1) mm outside diameter, (6.5 ± 0.1) mm internal diameter and (200 ± 5) mm in length, shall be connected by flexible tubing via a flowmeter, fine control valve, on-off valve (optional) and cylinder regulator providing a nominal outlet pressure of 2.8 kPa^1 to a cylinder containing butane (see BS 4250).

NOTE 1 Such steel tubing might be marketed as 5/16 in outside diameter, 0.028 in wall thickness. Where tubing of these dimensions is not readily available, stainless steel tubing of approximately similar dimensions may be used providing that the 50 mm length at the “flame” end of the tube is machined to the given size.

NOTE 2 Possible variations in performance might occur when the gas cylinder is nearly empty.

¹⁾ $1 \text{ kPa} = 10^3 \text{ N/m}^2 = 10 \text{ mbar}$.

The flowmeter shall be calibrated to supply butane gas flow rates as specified in Table 1. The flexible tubing connecting the output of the flowmeter to the burner tube shall be 2.5 m to 3.0 m in length with an internal diameter of (7.0 ± 1.0) mm.

NOTE 3 For information on gas flow control, see Annex C.

Table 1 **Parameters of butane gas ignition sources 1, 2 and 3**

Parameter	Value		
	Ignition source 1	Ignition source 2	Ignition source 3
Gas flow rate	(45 ± 2) ml/min at 25 °C ^{A)}	(160 ± 5) ml/min at 25 °C ^{A)}	(350 ± 10) ml/min at 25 °C ^{A)}
	(44 ± 2) ml/min at 20 °C	(157 ± 5) ml/min at 20 °C	(344 ± 10) ml/min at 20 °C
Gas burn time	(20 ± 1) s	(40 ± 1) s	(70 ± 1) s

^{A)} Under these conditions the flame height for source 1 is approximately 35 mm, for source 2 approximately 145 mm and for source 3 approximately 240 mm, measured from the top of the burner tube when held vertically upwards and when the flames are burning freely in air.

9.3 Crib, ignition sources 4, 5, 6 and 7

9.3.1 Materials

The cribs shall be constructed from the following materials:

- dry softwood *Pinus silvestris* (Scots pine) that has been stored in warm dry conditions for a minimum of 1 week;
- BPC grade absorbent surgical lint, approximately 200 g/m², cut into nominal squares 40 mm × 40 mm (each square having a mass of approximately 0.3 g);
- polyvinyl acetate (PVA) or other suitable wood adhesive for gluing together the sticks and lint.

NOTE Guidance on the selection of timber for crib construction is given in Annex A.

9.3.2 Assembly

The crib parameters shall conform to Table 2 and Table 3.

The construction of the cribs shall be as shown in Figure 6, Figure 7, Figure 8 and Figure 9 for sources 4 to 7 respectively.

NOTE Suggested methods of construction are given in Annex D.

The required number and sizes of sticks, conditioned in accordance with 10.1.2, shall be selected to provide the required total mass and shall be assembled into cribs with the square of lint incorporated, fluffy side uppermost when the crib is standing on its base. The sticks in each layer shall be parallel to one another and at right angles to the sticks in the adjacent layer. The sticks in each layer shall be placed as far away from each other as possible (except for the two main crib sticks forming the base of crib 6), but without undue overhang at their ends, to form a square-sectioned crib. The sticks shall be glued together and the lint secured with small amounts of the adhesive.

Table 2 Parameters of crib ignition sources 4 and 5

Parameter	Value	
	Ignition source 4	Ignition source 5
Stick length	(40 ± 2) mm	(40 ± 2) mm
Stick square section	(6.5 ± 0.5) mm	(6.5 ± 0.5) mm
Number of sticks	10	20
Total mass of sticks ^{A)}	(8.5 ± 0.5) g	(17 ± 1) g
Number of layers each of two sticks	5	10
Approximate lint dimensions	40 mm × 40 mm	40 mm × 40 mm

NOTE Guidance for test operators is given in Annex A.

^{A)} Test laboratories should establish differences in mass between those specified for the sticks and that of the final assembled crib including glue and lint.

Table 3 Parameters of crib ignition sources 6 and 7

Parameter	Value	
	Ignition source 6	Ignition source 7
Main crib stick length	(80 ± 2) mm	(80 ± 2) mm
Main crib stick square section	(12.5 ± 0.5) mm	(12.5 ± 0.5) mm
Number of sticks main crib	8	18
Number of layers each of two sticks in main crib	4	9
Ignition crib base stick length	(80 ± 2) mm	(80 ± 2) mm
Ignition crib stick length	(40 ± 2) mm	(40 ± 2) mm
Square section of all sticks in the ignition crib	(6.5 ± 0.5) mm	(6.5 ± 0.5) mm
Number of ignition crib base sticks	2	4
Number of ignition crib sticks	8	6
Number of layers each of two sticks in ignition crib	5	5
Total mass of main and ignition crib sticks ^{A)}	(60 ± 2) g	(126 ± 4) g
Approximate lint dimensions	40 mm × 40 mm	40 mm × 40 mm

NOTE Guidance for test operators is given in Annex A.

^{A)} Test laboratories should establish differences in mass between those specified for the sticks and that of the final assembled crib including glue and lint.

Figure 6 Crib ignition source 4

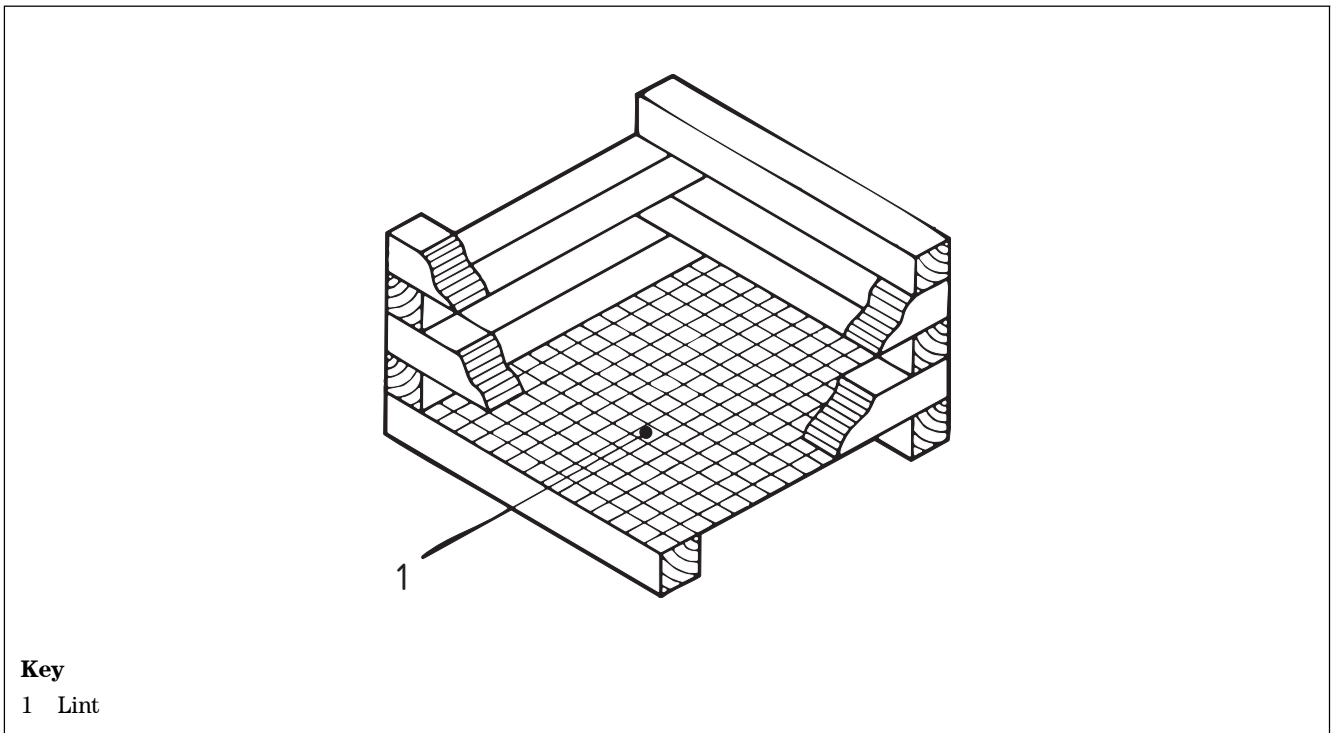

Figure 7 Crib ignition source 5

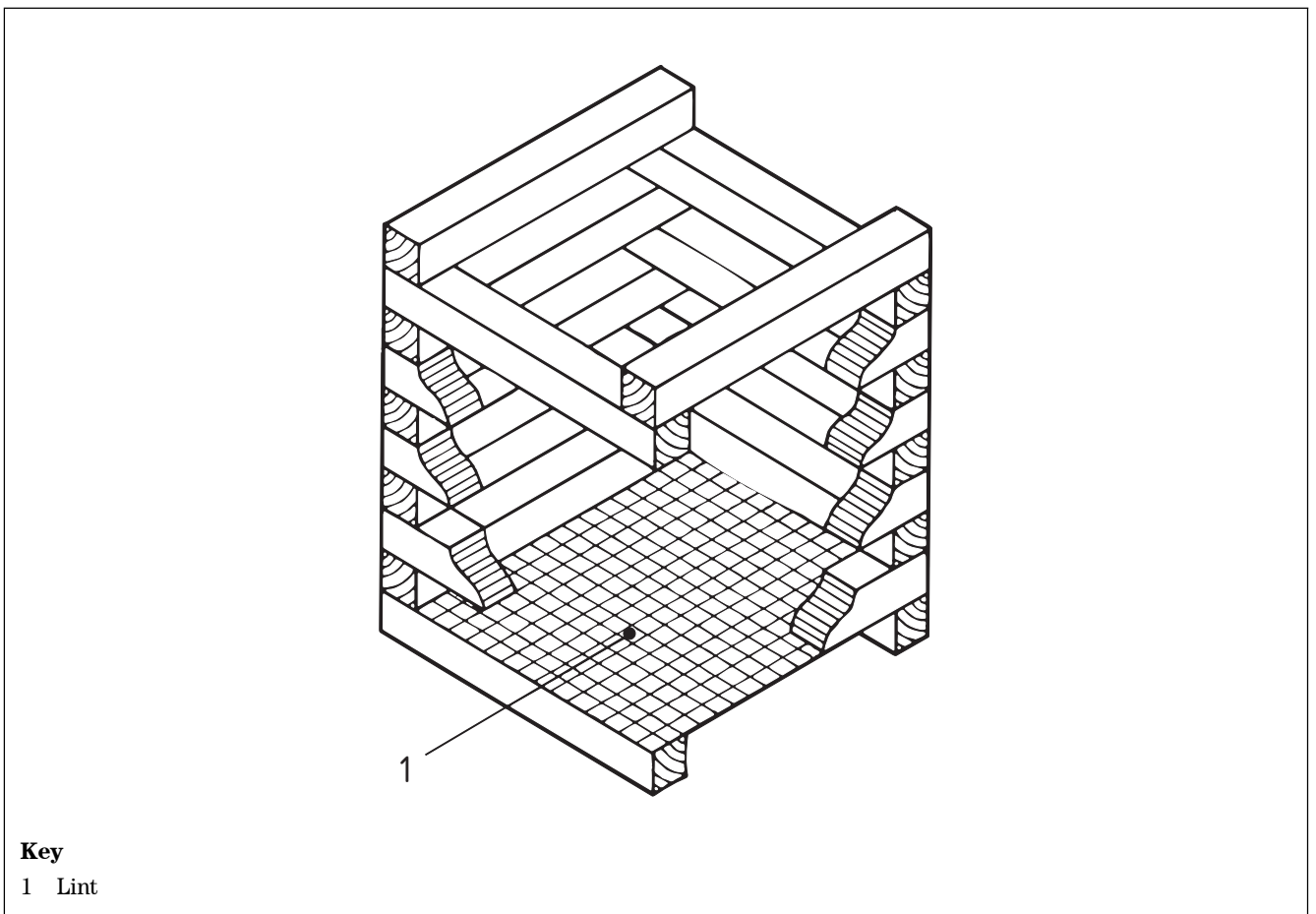
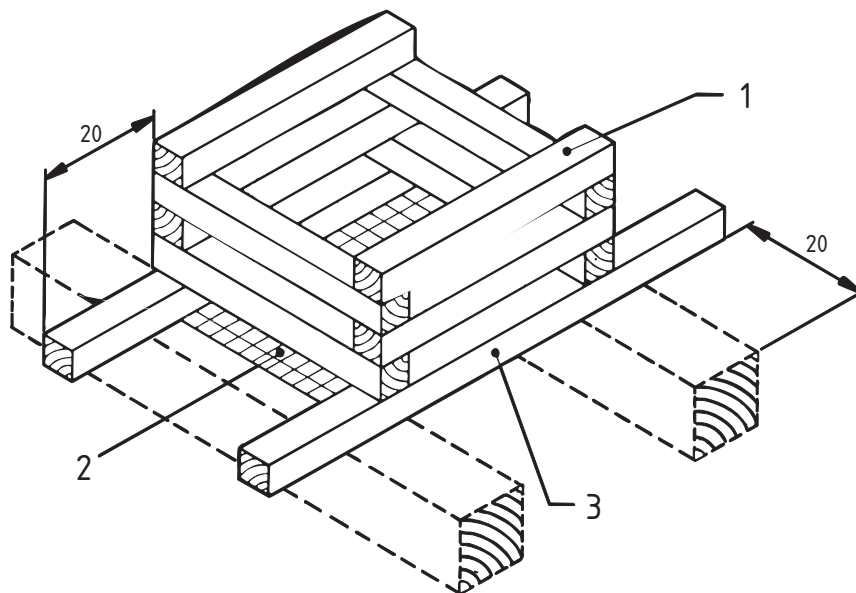
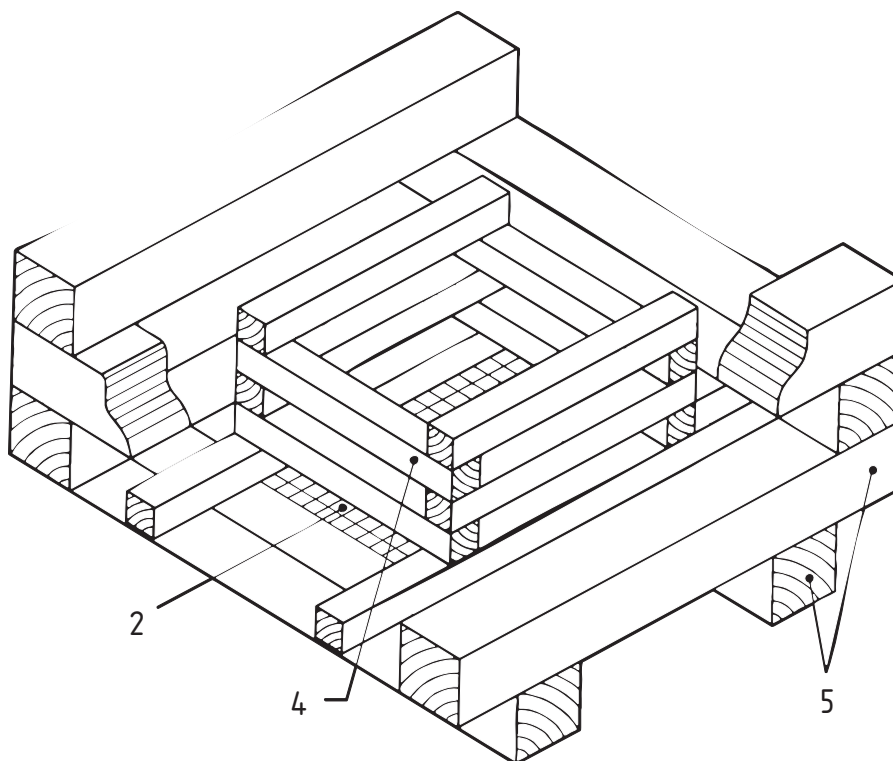

Figure 8 Crib ignition source 6

Dimensions in millimetres



a) Construction B



b) Complete crib

Key

- 1 Ignition crib sticks, (40 ± 2) mm in length
- 2 Lint
- 3 Ignition crib base sticks, (80 ± 2) mm in length
- 4 Ignition crib (construction B)
- 5 Main crib sticks, (80 ± 2) mm in length (construction A)

Figure 9 Crib ignition source 7

Dimensions in millimetres

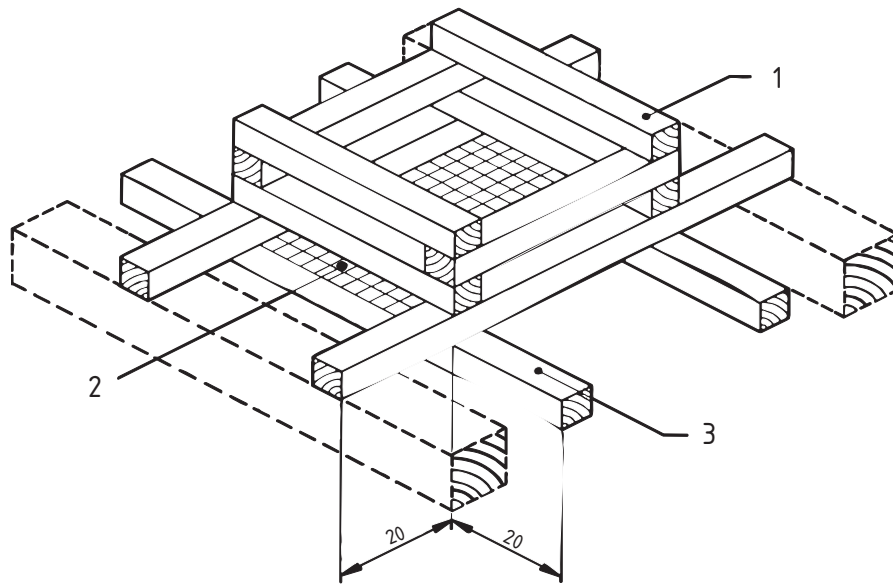

a) Construction B

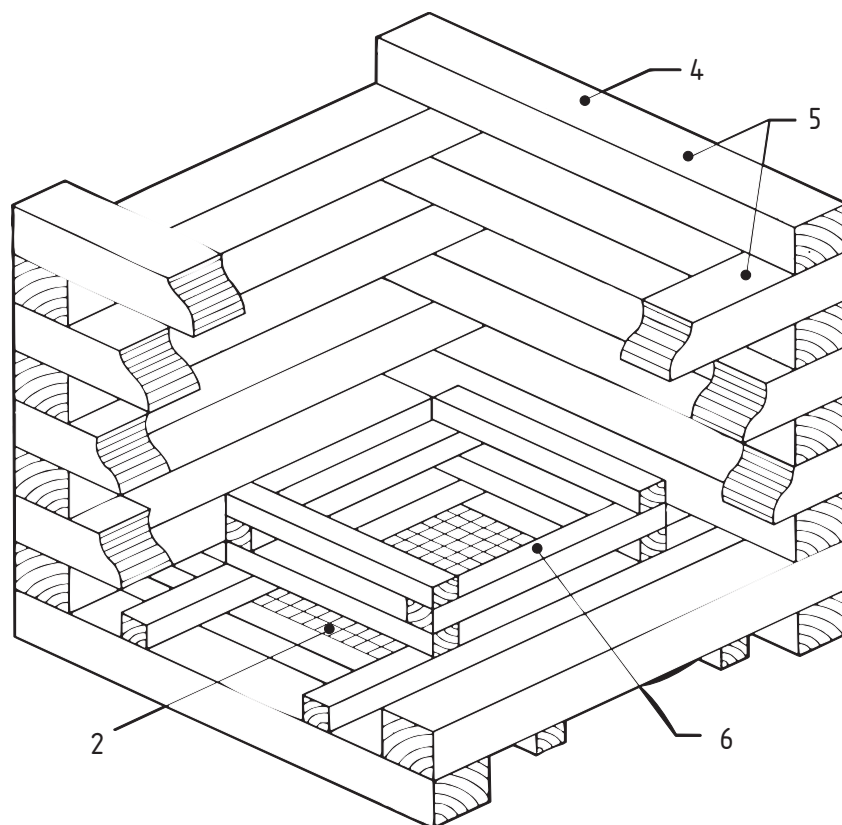

b) Complete crib

Key

- | | |
|--|---|
| 1 Ignition crib sticks, (40 ± 2) mm in length | 4 Main crib body (construction A) |
| 2 Lint | 5 Main crib sticks, (80 ± 2) mm in length |
| 3 Ignition crib base sticks, (80 ± 2) mm in length | 6 Ignition crib (construction B) |

10 Atmosphere for conditioning and testing

10.1 Conditioning

NOTE Certain performance specifications and upholstered furniture safety regulations might require additional pre-treatment, e.g. a water soak before conditioning.

10.1.1 All outer covers and inner covers that have been chemically treated to reduce their ignitability shall be subjected to the water soaking and drying procedure described in Annex E prior to being conditioned in accordance with **10.1.2**. This shall be carried out for all methods of treatment, including backcoating, that are applied to covers that are finished in all other respects. It shall not be carried out when the cover material is manufactured from materials that are formulated to be, or are inherently, flame-retarded (e.g. fabric woven from flame-retarded yarns, PVC) provided that it is not further treated as a finished cover material. Where it is not known whether the material has been treated or not, the water soaking and drying procedure shall be performed.

10.1.2 The materials to be tested and the cribs shall be conditioned before the test for at least 72 h in indoor ambient conditions and then immediately before the test for at least 24 h in the following atmosphere:

- temperature: (23 ± 2) °C;
- humidity: $(50 \pm 5)\%$.

10.1.3 Fabrics shall be line dried by hanging a single vertical sheet from the shorter edge of the test specimens nearest the cut-outs.

10.2 Testing

For testing, a substantially draught-free environment having a temperature of 10 °C to 30 °C and a relative humidity of 15% to 80% shall be used.

11 Methods of test for the ignitability of upholstery composites

11.1 Principle

Materials forming an upholstery composite are assembled together on the test rig (see **7.1**). This apparatus incorporates features designed to model the aspects of upholstered seating critical to ignition and so to provide a means of measuring the potential ignitability of the composite.

The test specimen consists of vertically and horizontally oriented components which comprise a single combination of covering fabric, interlining (if used) and filling material.

The test specimen usually comprises a single fabric, interlining (if used) and filling. If the proposed item of furniture comprises different combinations of materials in the seat, back and arms, all such combinations are tested separately on the rig.

NOTE The tests given in this clause are subject to certain limitations (see Annex B).

11.2 Test specimens

11.2.1 General

The test specimen shall be a structure comprising vertical and horizontal parts of the composite of upholstery materials submitted for testing.

These materials shall be representative of the cover, filling and other components to be used in the upholstery composites.

The components forming the test composite shall be representative of the upper 75 mm of the upholstery of the upholstered furniture.

11.2.2 Cover material and fabric interliner

Test specimens used on the test rig described in 7.1 shall be as shown in Figure 10.

The long dimension shall be cut parallel to the machine direction, except when it is different to the lie of the pile. If the cover is constructed from smaller pieces of test materials, the resulting seams shall not occur within 100 mm of the area likely to be affected by the test or shall be located behind the pivot bar. If lack of test materials requires the use of additional alternative material, e.g. side extensions, their use shall be stated in the test report (see Clause 13).

The cut-outs shall be positioned such that when assembled on the test rig the lie of any pile is down the vertical assembly and from the hinge to the front of the horizontal assembly. Where a fabric interliner is used it shall be cut to the same dimensions, and in the same orientation as the cover, for fitting to the test rig under the cover.

If two or more different combinations of covering fabric, interlining and filling material exist in the upholstery of the upholstered furniture then each different combination shall be tested using separate test specimens comprising a single covering fabric, interliner (if used) and filling material.

NOTE Tests in which more than one combination of fabric, interliner and filling are used to model the seat/back junction of a seat are described in Annex B.

Figure 10 Details of test specimens for covers and interliners for use with the test rig

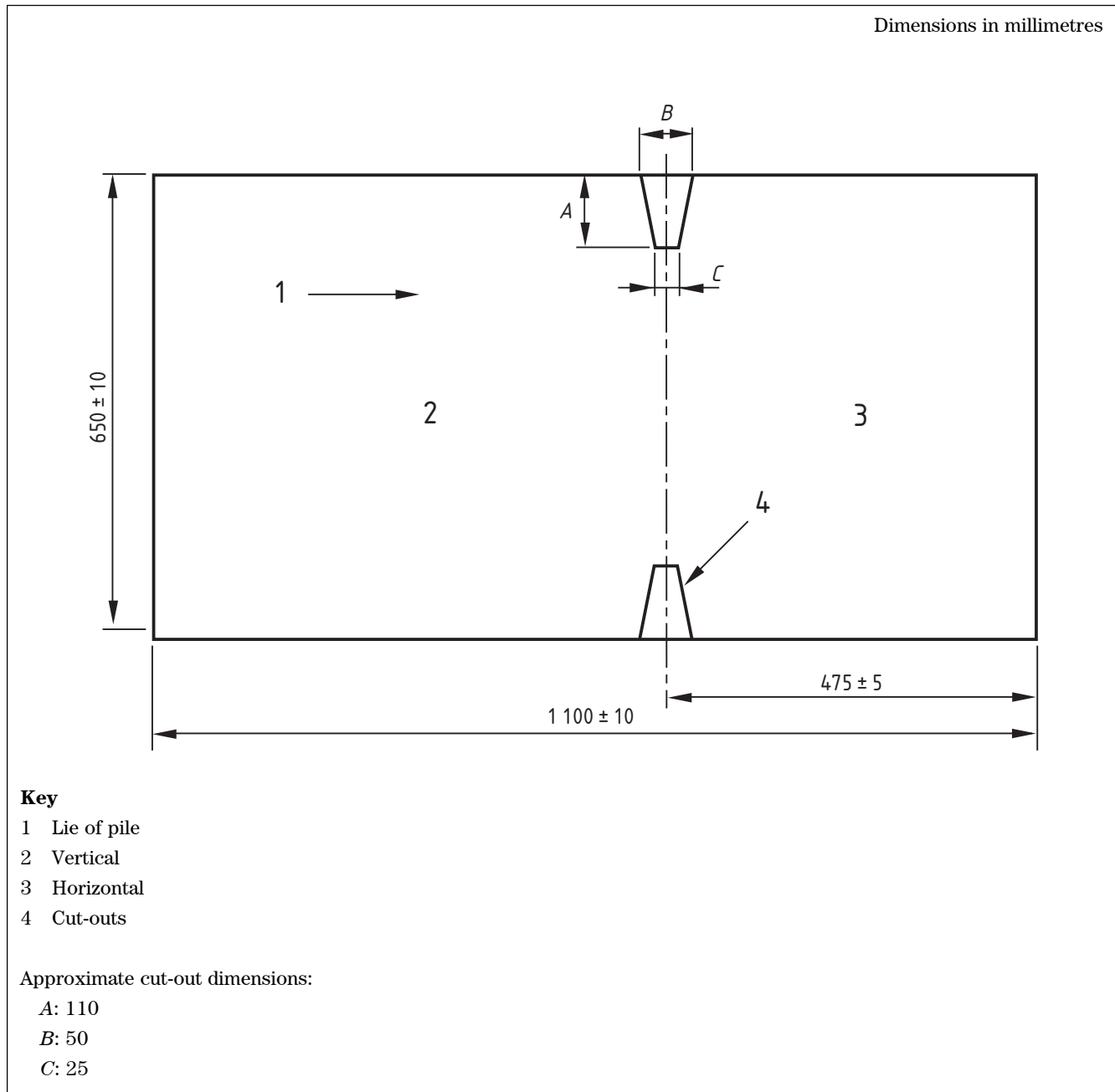

11.2.3 Upholstery filling

Two pieces of filling, one (450 ± 5) mm \times (450 ± 5) mm \times (75 ± 2) mm thick and the other (450 ± 5) mm \times (300 ± 5) mm \times (75 ± 2) mm thick, shall be provided for each test.

For cushioning assemblies that consist of several layers (typically felt, wadding or various foams), where the total thickness exceeds 75 mm, the upper 75 mm of the cushioning assembly shall be reproduced, except that the upper layer(s) do not need to be continued over and round the edges of the assembly.

Where the filling is less than 75 mm thick the test piece shall be built up to the required thickness by adding to the underside a further layer or layers of the bottom material.

If lack of test materials requires the use of additional alternative materials such as side extensions, the additional materials shall not be positioned within 100 mm of the ignition source, or above the top of the ignition source if used in the vertical part of the test specimen. The use of additional materials shall be noted in the test report (see Clause 13).

If loose filling materials, e.g. foam crumb or feathers, are to be evaluated by this method of test, the loose filling shall be built up beneath the covering materials to reproduce the 75 mm thickness of the assembly at a realistic filling density. Where necessary, a finer grid material or air porous fabric shall be laid over the expanded metal of the test rig to retain the filling.

NOTE 1 If, in use, the loose filling is enclosed in an interlining (or ticking) it is acceptable to make up two bags of the interlining suitably filled and to the overall dimensions given above for use as the upholstery filling beneath the cover(s).

NOTE 2 The tests described in Clause 11 are unsuitable when used with composites where the loose filling material flows out of the assembly during the test and either extinguishes, moves or adversely affects the burning of the ignition source. A more relevant result might be obtained when such materials are tested as a complete item of furniture as described in Clause 12.

11.3 Ignition sources

The ignition sources to be used shall conform to sources 2 to 7 described in Clause 9, and the cigarette and match flame equivalent sources described in BS EN 1021-1 and BS EN 1021-2.

11.4 Procedure

11.4.1 Preparation

11.4.1.1 Ensure that the means of extinguishing the test specimens are close to hand (see 6.2).

11.4.1.2 Open out the test rig and thread the covering fabric and, if used, the fabric interliner, behind the hinge bar so that the cut-outs are aligned with the hinge bar.

11.4.1.3 Place the filling pieces under the covering fabric(s) and locate the filling pieces in the frame recesses.

11.4.1.4 Lock the frames as shown in Figure 5 using the two bolts or single pin, ensuring that the movement between the vertical and horizontal components of the undressed rig does not cause the angle to move outside the range of $(90 \pm 2.5)^\circ$. Fasten the fabric(s) over the top, bottom and sides of the frame using clips and ensure that the fabric(s) is secured and under even tension, by allowing approximately 20 mm of fabric to wrap around the frame so that the edge of the fabric just contacts the expanded metal.

11.4.2 Butane flame test: ignition sources 2 and 3

NOTE A flow diagram for detection of ignition is given in Figure 2.

11.4.2.1 Light the butane emerging from the burner tube, adjust the gas flow to the appropriate rate (see Table 1) and allow the flame to stabilize for at least 2 min.

11.4.2.2 Position the burner tube axially along the junction between the vertical and horizontal parts of the test specimen so that the flame is not less than 100 mm from the nearest side, edge, or any marks left by any previous test, and simultaneously start the clock. Use a fresh test specimen if a position meeting these criteria cannot be found.

11.4.2.3 Allow the gas to burn for the appropriate time (see Table 1) before removing the burner tube from the test specimen.

11.4.2.4 Observe for evidence of ignition (see Clause 4) in the interior and/or cover.

11.4.2.5 If flaming ignition (see 4.2) of the test specimen is observed, extinguish the test specimen, note the time the test was stopped and the reason, record that ignition has occurred for the ignition source used and discontinue testing.

11.4.2.6 If flaming ignition (see 4.2) is not observed, continue to observe the test site for evidence of progressive smouldering ignition (see 4.1). If progressive smouldering ignition is observed, extinguish the test specimen, note the time the test was stopped and the reason, record that ignition has occurred for the ignition source used and discontinue testing.

11.4.2.7 If no ignition is observed, repeat the test (once only) as described in 11.4.2.2 using a new test position.

11.4.2.8 If flaming ignition (see 4.2) is observed on the repeat test, extinguish the test specimen, note the time the test was stopped and the reason and record that ignition has occurred for the ignition source used.

11.4.2.9 If flaming ignition (see 4.2) is not observed on the repeat test, continue to observe the test site for evidence of progressive smouldering ignition (see 4.1). If progressive smouldering ignition is observed, extinguish the test specimen, note the time the test was stopped and the reason and record that ignition has occurred for the ignition source used.

11.4.2.10 If no ignition is observed on the repeat test, record non-ignition for the ignition source unless the test specimen fails the final examination described in Clause 13. In this case, record that ignition has occurred for the ignition source used.

11.4.3 Wooden crib test: ignition sources 4, 5, 6 and 7

NOTE A flow diagram for detection of ignition is given in Figure 3.

11.4.3.1 Use a new specimen for each test. After the assembly of a crib (see 9.3.2) and after conditioning it (see Clause 10), add slowly (1.4 ± 0.1) ml of propan-2-ol to the centre of the lint using the measuring instrument (7.6). Place the wooden crib on the test specimen so that the bottom of the crib nests at the junction between the vertical and horizontal part of the test rig, with the lint at the bottom of the crib, the crib touching the vertical face of the cover, and the bottom stick of the crib parallel to the hinge pin of the test rig.

11.4.3.2 Within 2 min of adding the propan-2-ol to the lint, ignite the alcohol from the front and above the lint, using a match, small gas flame or hot wire ignition, and simultaneously start the clock. If the crib collapses causing embers to be scattered over a distance greater than 100 mm measured from the edge of the crib, repeat the test with a new crib placed in position as described in 11.4.3.1 on a new test specimen.

11.4.3.3 Observe for evidence of ignition (see Clause 4) in the interior and/or cover.

11.4.3.4 If flaming ignition (see 4.2) of the test specimen is observed, extinguish the test specimen, note the time the test was stopped and the reason, record that ignition has occurred for the ignition source used and discontinue testing.

11.4.3.5 If flaming ignition (see 4.2) is not observed, continue to observe the test site for evidence of progressive smouldering ignition (see 4.1). If progressive smouldering ignition is observed, extinguish the test specimen, note the time the test was stopped and the reason, record that ignition has occurred for the ignition source used and discontinue testing.

11.4.3.6 If no ignition is observed, repeat the test (once only) as described in 11.4.3.1.

11.4.3.7 If flaming ignition (see 4.2) is observed on the repeat test, extinguish the test specimen, note the time the test was stopped and the reason and record that ignition has occurred for the ignition source used.

11.4.3.8 If flaming ignition (see 4.2) is not observed on the repeat test, continue to observe the test site for evidence of progressive smouldering ignition (see 4.1). If progressive smouldering ignition is observed, extinguish the test specimen, note the time the test was stopped and the reason and record that ignition has occurred for the ignition source used.

11.4.3.9 If no ignition is observed on the repeat test, record non-ignition for the ignition source unless the test specimen fails the final examination described in Clause 13. In this case, record that ignition has occurred for the ignition source used.

11.5 Test results

The ignitability performance of a test specimen shall be designated by the number of the clause of BS 5852:2006 together with the ignition source to which the test specimen was subjected preceded by the letters “NI” if the specimen did not ignite or by the letter “I” if it did ignite.

EXAMPLES A specimen tested over the range of sources 2 to 7 but failing at source 7 would be designated “BS 5852:2006, Clause 11, NI/2-6, I/7”. A specimen tested with sources 4 and 5 but failing at source 5 would be designated “BS 5852:2006, Clause 11, NI/4, I/5”.

12 Methods of test for the ignitability of complete items of furniture

WARNING. In addition to the general advice given in Clause 6, attention is specifically drawn to the rapid fire development and large fires which might be generated by upholstered chairs, sofas, etc. If a chair incorporates a pressurized gas cylinder then special care should be taken since the gas is likely to be under a very high pressure. Gas cylinders should be depressurized or removed.

NOTE 1 Tests on upholstery materials in isolation cannot give a true indication of what their ignition behaviour will be when tested as a composite assembly. Similarly, assemblies can be influenced by the introduction of additional materials, by the design of the finished product or by the location or zone on the product to which the ignition source is applied.

This clause provides a means of assessing the ignitability of a complete item of seating furniture taking account of all these factors. It is equally applicable whether the furniture is upholstered or not and can be used to test upholstered items with no structural frame, e.g. bean bags, or small items where insufficient material is available for testing in accordance with Clause 11.

NOTE 2 It is desirable that ignition tests in accordance with this clause should be conducted on a single test specimen. It is critical, therefore, that the programme of proposed ignition tests is planned carefully.

12.1 Principle

A complete item of furniture is subjected to ignition tests with the ignition source:

- a) within the seating area;
- b) at floor level outside the seating area adjacent to a vertical surface or beneath an overhang;
- c) at floor level underneath the test specimen.

In each of these tests the most vulnerable zones are tested.

The zones are first tested using a smouldering cigarette and then either flaming ignition sources of progressive intensity or a single specified flaming source.

12.2 Test specimens

The test specimen shall be an item of furniture, complete with any cushions, loose covers or other intended attachments and finished in its ready-for-use condition or, if different, its ready-for-sale condition.

NOTE For multiple seating items such as two- and three-seater settees, bench or banquette seating, an end section comprising one seating unit approximately 0.75 m wide, may be submitted for testing. Sub-assemblies may also be tested where specific information is required.

12.3 Test zones

12.3.1 General

NOTE 1 The number of different styles, designs and intended uses for items of furniture makes it impossible to specify a complete list of test zones for all items. The principle for selecting test zones is to consider the most vulnerable positions where an ignition source might rest and result in ignition. To facilitate this selection, a series of model positions for the ignition source are defined and illustrated in Figure 11, Figure 12, Figure 13 and Figure 14, and the tester is required to select actual positions on the test specimen which approach these models as nearly as possible.

NOTE 2 A wooden crib is shown as the ignition source only as an example. Figure 11 to Figure 14 are equally valid for all ignition sources.

Where doubt exists as to which is the most vulnerable test zone, all such positions shall be tested. Furniture containing loose cushions shall be tested with the loose cushions in the normal use position.

All the applicable zones in each category shall be tested, starting with the smouldering ignition source, then progressive or nominated flaming sources within the seating area and finally tests at floor level below or against the test specimen.

12.3.2 Smouldering ignition in the seating area

Where possible, testing shall be carried out in the model position for the ignition source, which has the following features in increasing order of importance:

- a) any surface which can retain the cigarette;
- b) a groove, recess or junction which can retain the cigarette;
- c) as item b), and long enough to fully support the cigarette;
- d) as item b) or c), in the position giving maximum contact to the peripheral area of the cigarette and ensuring an adequate supply of air;
- e) as item a), b), c) or d), where the padding is thickest.

If this model position does not exist, the closest matching position shall be used.

If loose cushions are present the tests shall be repeated with the lighted cigarette placed in the equivalent position on the platform and the cushion replaced.

12.3.3 Flaming ignition in the seating area

12.3.3.1 Seating with back and arms

Where possible, the model position shown in Figure 11 for the appropriate type of chair shall be used, with the ignition source positioned such that its centreline is in the same plane as the back of the chair and with the ignition source adjacent to the arms. If this model position does not exist, the closest matching position shall be used (see Figure 12 and Figure 13).

Where back pads are adjustable in height, the test shall be carried out in the position closest to that illustrated in Figure 11. A second test shall be carried out with the back pad in its lowest position where this is different from the first test.

Where seat angle and back angle are adjustable they shall be adjusted to be closest to the horizontal and vertical respectively.

12.3.3.2 Seating with back but without arms

Where possible, the model position shown in Figure 12 for the appropriate type of chair shall be used, with the ignition source positioned such that it is not less than 100 mm from the nearest side, edge, or marks left by any previous test. If this model position does not exist, the closest matching position shall be used.

12.3.3.3 Seating without back or arms

Where possible, the test shall be carried out on the seat such that no part of the ignition source is less than 100 mm from the nearest side, edge, or any marks left by any previous test. If this model position does not exist, the closest matching position shall be used.

12.3.3.4 Tip-up seating

For tip-up seating, in addition to tests in the seat-lowered configuration (secured in the seat-lowered position if necessary) carried out in accordance with 12.3.4.1 and 12.3.4.2, the item shall be tested in the seat-up configuration. Where possible, the model position shown in Figure 13 for the appropriate type of chair shall be used. If this model position does not exist, the closest matching position shall be used.

12.3.4 Flaming ignition from floor level

12.3.4.1 Peripheral ignition

The ignition source shall be placed on the floor directly below the most vulnerable feature of the side, front or rear of the test specimen. If the clearances beneath any edge of the test specimen do not permit this the ignition source shall be positioned adjacent to the most vulnerable feature (see Figure 14).

12.3.4.2 Ignition from beneath

If the clearances beneath the edge of the specimen permit or if the seat is not adjustable, the ignition source shall be positioned on the floor directly beneath the most vulnerable feature of the underside of the test specimen. The distance of the test specimen above the top of the ignition source shall be not less than the minimum specified in Table 4. For specimens where the seat height is adjustable, the seat height shall be adjusted such that the distance between the top of the ignition source and the most vulnerable feature is closest to the clearance given in Table 4.

Table 4 **Minimum distance of test specimen above top of ignition source**

Ignition source	Minimum distance a (see Figure 14) mm
1	5
2	10
3	15
4	20
5	30
6	60
7	100

12.3.5 Deliberate ignition

If an item of furniture is required to be resistant to deliberate ignition by small flaming sources representing hand-held matches or cigarette lighters applied to the underneath of a test specimen, then butane flame ignition sources 1 and/or 2 and/or 3 shall be applied to the most vulnerable zone.

Figure 11 Model position for ignition source in seating area

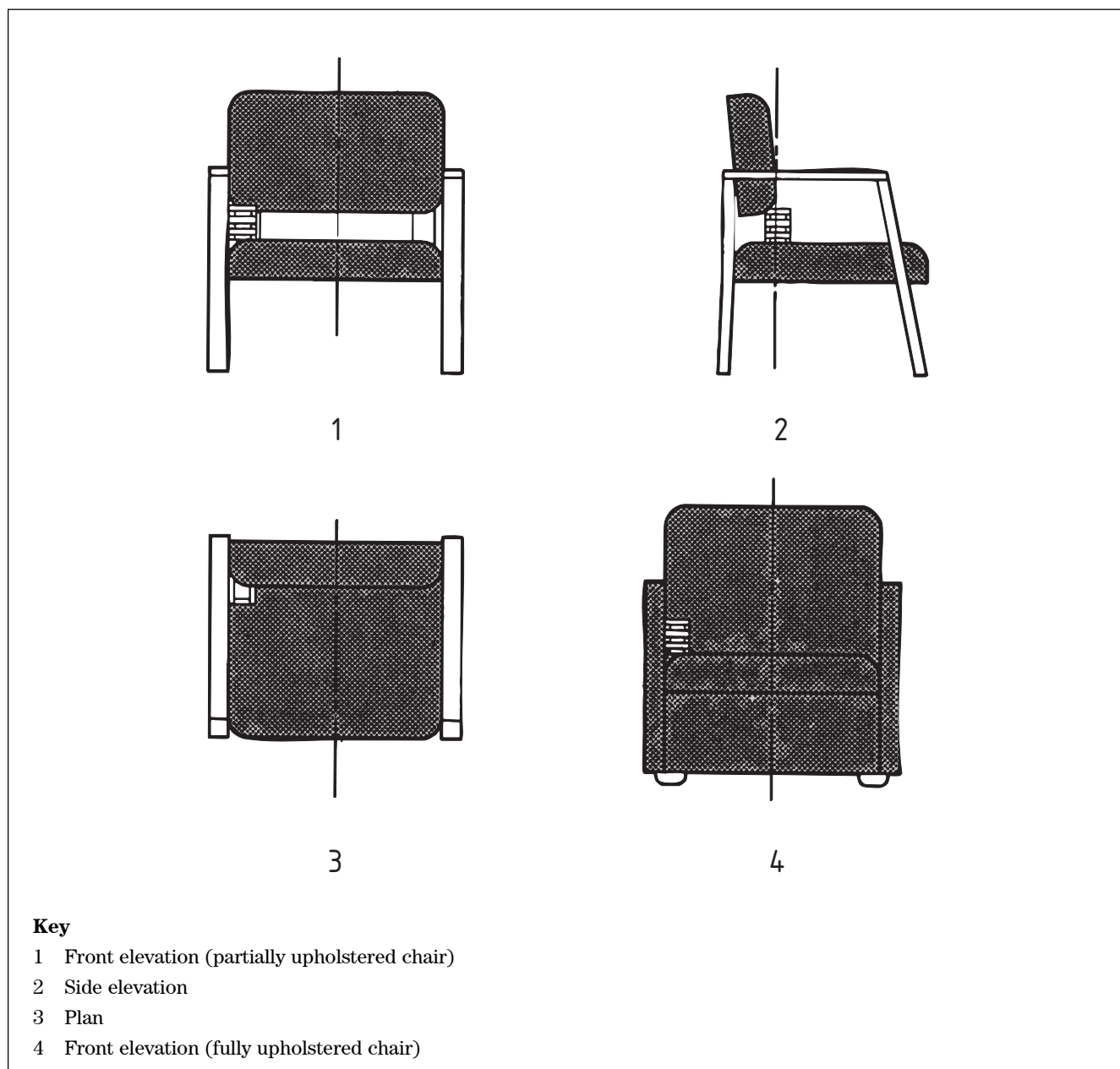

Figure 12 Alternative positions for ignition source in seating area

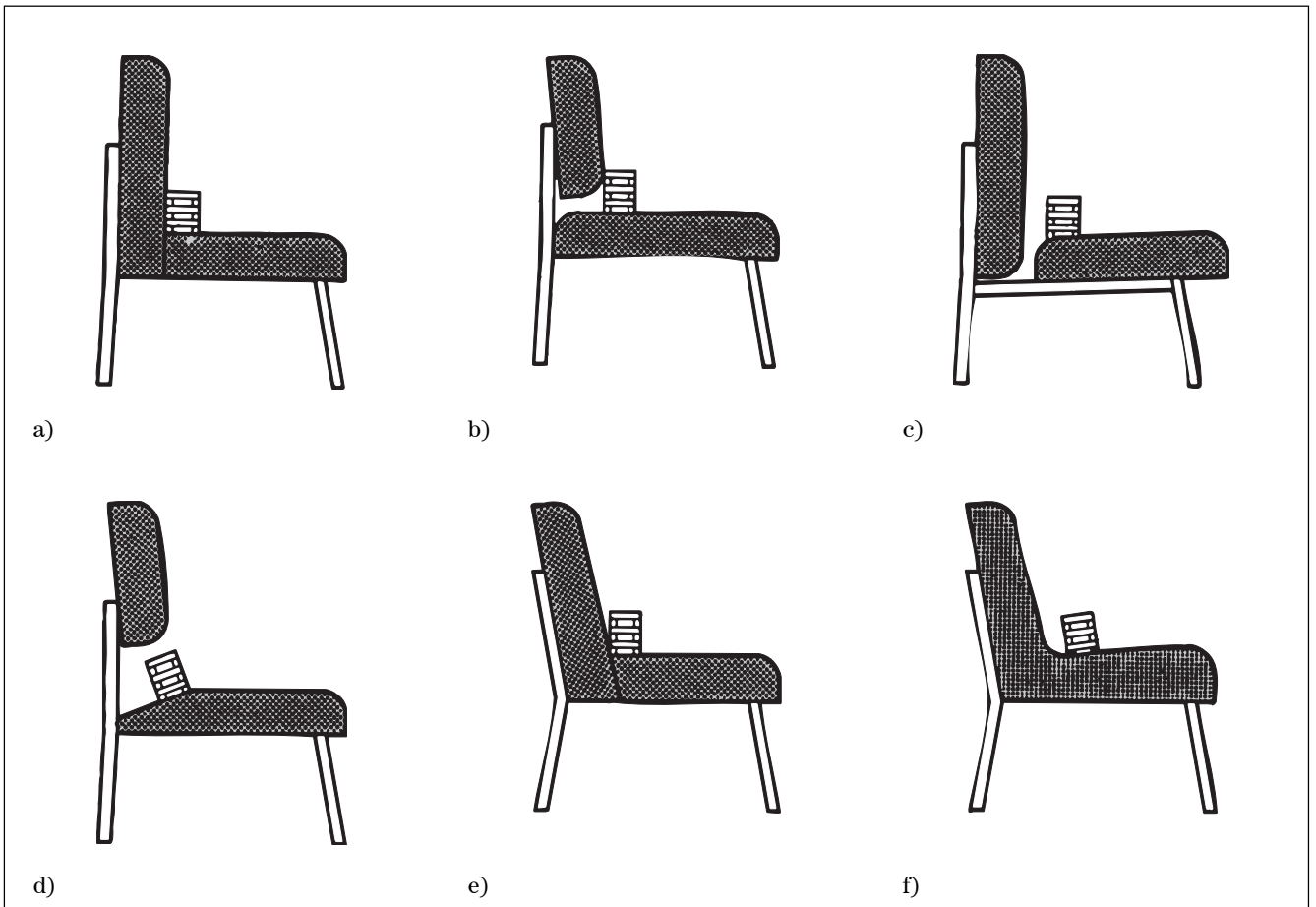

Figure 13 Additional model positions of ignition sources for tip-up seats

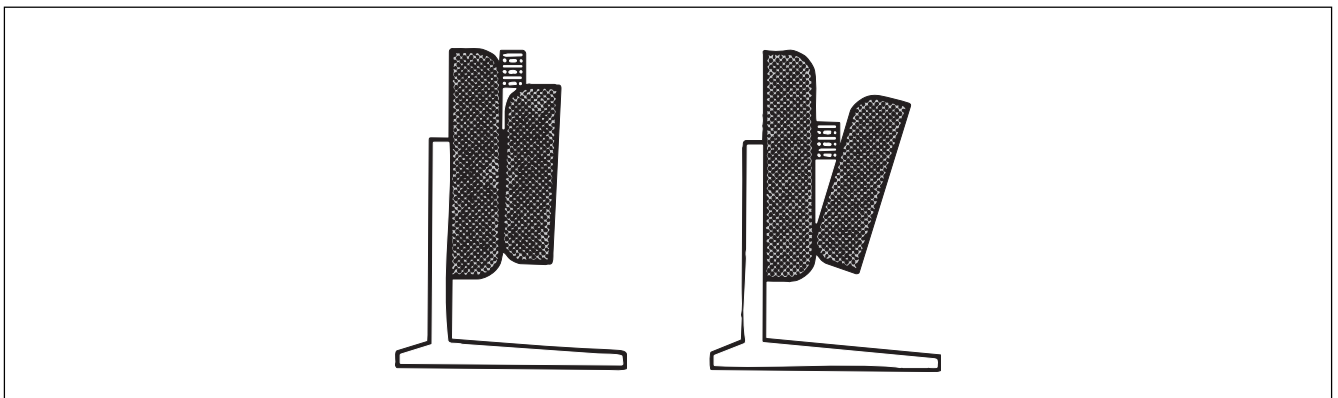
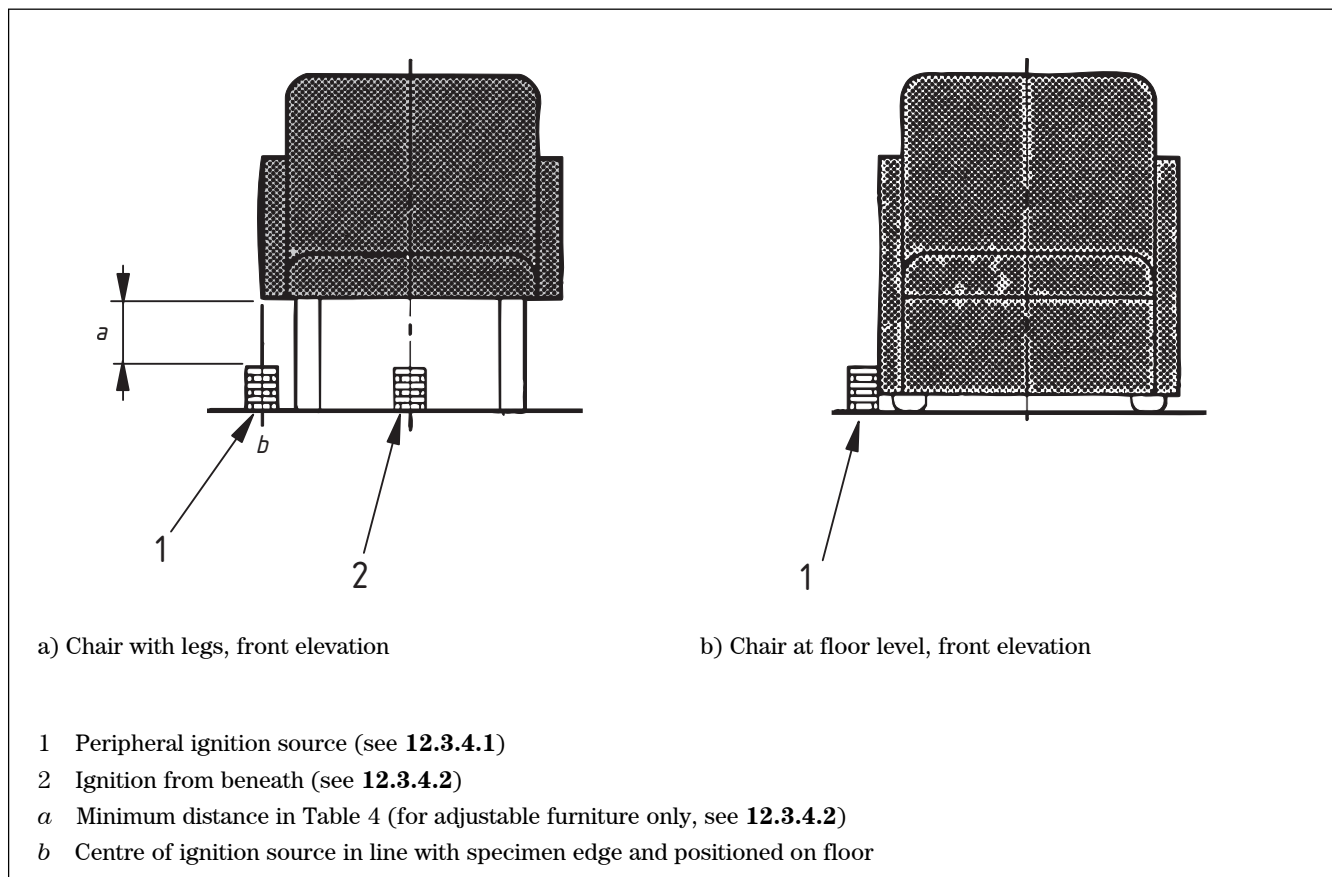

Figure 14 Model position for ignition source at floor level



12.4 Ignition sources

The ignition sources to be used shall conform to sources 0 to 7 described in Clause 8 and Clause 9.

12.5 Procedure

NOTE Many pieces of upholstered furniture represent a significantly greater fire load than the test specimens of Clause 11. Attention is drawn to the precautions that have to be taken to meet the requirements of the Health and Safety at Work etc. Act 1974 [5].

12.5.1 Preparation

12.5.1.1 Ensure that the means of extinguishing the test specimens are close at hand (see 6.2).

12.5.1.2 Within 5 min of transferring the test specimen from the conditioning atmosphere, stand the item on a level surface in the test chamber and start the test. The surface used shall represent floor level. Position the test specimen so that the test zone is not less than 0.5 m from the nearest enclosure wall.

12.5.2 Smouldering cigarette test: ignition source 0

NOTE A flow diagram for detection of ignition is given in Figure 1.

12.5.2.1 Ignite the cigarette (see BS EN 1021-1) and immediately place it in position on a nominated test zone (see **12.3.2**) and simultaneously start the clock. The cigarette shall rest in contact with the test zone and shall not be pressed down.

12.5.2.2 Observe the progress of combustion, and record any evidence of ignition (see Clause 4) in the interior and/or cover.

NOTE The detection of smouldering can be difficult and is eased by watching for smoke emerging at points at a distance from the cigarette. Smoke is most easily viewed by looking down a rising column by means of a mirror.

12.5.2.3 If progressive smouldering ignition (see **4.1**) or flaming ignition (see **4.2**) of the test specimen is observed, extinguish the test specimen, note the time the test was stopped and the reason, record that ignition has occurred for the ignition source used and discontinue testing.

12.5.2.4 If progressive smouldering ignition (see **4.1**) or flaming ignition (see **4.2**) of the test specimen is not observed or if the cigarette fails to smoulder its complete length, repeat the test (once only) with a new cigarette placed in a fresh position not less than 100 mm from any previous test damage.

12.5.2.5 If progressive smouldering ignition (see **4.1**) or flaming ignition (see **4.2**) is not observed on the repeat test or if the cigarette fails to smoulder its complete length, record non-ignition for the ignition source used, unless the test specimen fails the final examination specified in Clause 13. In this case, extinguish the test specimen and record that ignition has occurred for the ignition source used.

12.5.2.6 Repeat **12.5.2.1** to **12.5.2.5** for all other nominated test zones.

NOTE Duplicate tests and tests on different zones may be run concurrently.

12.5.3 Butane flame test: ignition sources 1, 2 and 3

NOTE A flow diagram for detection of ignition is given in Figure 2.

12.5.3.1 Light the butane emerging from the burner tube, adjust the gas flow to the appropriate rate (see Table 1) and allow the flame to stabilize for at least 2 min.

12.5.3.2 Position the burner tube horizontally at a nominated test zone (see **12.3.3** and **12.3.4**).

12.5.3.3 Allow the gas to burn for the appropriate time (see Table 1) before removing the burner tube from the test specimen.

12.5.3.4 Observe for evidence of ignition (see Clause 4) in the interior and/or cover.

12.5.3.5 If progressive smouldering ignition (see 4.1) or flaming ignition (see 4.2) of the test specimen is observed, extinguish the test specimen, note the time the test was stopped and the reason, record that ignition has occurred for the ignition source used and discontinue testing.

12.5.3.6 If progressive smouldering ignition (see 4.1) or flaming ignition (see 4.2) of the test specimen is not observed, repeat the test (once only) as described in 12.5.3.2 using a new test position at least 100 mm from any previous test damage.

12.5.3.7 If progressive smouldering ignition (see 4.1) or flaming ignition (see 4.2) is not observed on the repeat test, record non-ignition for the ignition source used, unless the test specimen fails the final examination specified in Clause 13. In this case, extinguish the test specimen and record that ignition has occurred for the ignition source used.

12.5.3.8 Repeat 12.5.3.1 to 12.5.3.7 for all other nominated test zones.

NOTE If deliberate hand-held match or cigarette lighter ignition is being simulated, the ignition source should be positioned as in 12.5.3.2 so that the top of the flame is in contact with the surface of the test zone. This can be achieved by means of a non-combustible spacer disc fitted to the burner tube. Suitable sizes for such spacers have been found to be 35 mm for ignition source 1, 145 mm for ignition source 2 and 240 mm for ignition source 3. The position of the spacer disc should not interfere with the contact between the test flame and the test zone.

12.5.4 Wooden crib test: ignition sources 4, 5, 6 and 7

NOTE A flow diagram for detection of ignition is given in Figure 3.

12.5.4.1 After the assembly of a crib (see 9.3.2) and after conditioning it (see Clause 10), add slowly (1.4 ± 0.1) ml of propan-2-ol to the centre of the lint using the measuring instrument (7.6). Place the crib at a nominated test zone (see 12.3.3 and 12.3.4) and at least 170 mm from any previous damage.

12.5.4.2 Within 2 min of adding the propan-2-ol to the lint, ignite the alcohol from the front and above the lint, using a match, small gas flame or hot wire ignition, and simultaneously start the clock. If the crib collapses causing embers to be scattered over a distance greater than 100 mm measured from the edge of the crib, repeat the test with a new crib placed in the nominated position at least 170 mm from any previous damage.

12.5.4.3 Observe for evidence of ignition (see Clause 4) of any trimmings or other accessories or of the cover, bottoming cloth and/or interior of the specimen. Disregard flames or afterglow that cease within 10 min of the ignition of cribs 4 and 5, or within 13 min of the ignition of cribs 6 and 7. Observe for a total of up to 60 min from commencement to establish the presence of progressive smouldering.

12.5.4.4 If progressive smouldering ignition (see 4.1) or flaming ignition (see 4.2) of the test specimen is observed, extinguish the test specimen, note the time the test was stopped and the reason, record that ignition has occurred for the ignition source used and discontinue testing.

12.5.4.5 If progressive smouldering ignition (see **4.1**) or flaming ignition (see **4.2**) of the test specimen is not observed, record non-ignition for the ignition source(s) used, unless the test specimen fails the final examination specified in Clause **13**. In this case, extinguish the test specimen and record that ignition has occurred for the ignition source used.

12.5.4.6 Repeat **12.5.4.1** to **12.5.4.5** for all other nominated test zones (but see Foreword).

12.6 Test results

The ignitability performance of a test specimen shall be designated by the number of the clause of BS 5852:2006 together with the ignition source to which the test specimen was subjected preceded by the letters “NI” if the specimen did not ignite or by the letter “I” if it did ignite. The results with source 0 (NI/0 or I/0) shall be quoted separately from flaming sources.

EXAMPLES A specimen tested only with sources 0 and 3 and passing both would be designated “BS 5852:2006, Clause **12**, NI/0, NI/3”. A specimen tested over the range of sources from 0 to 7, but failing at sources 0 and 7, would be designated “BS 5852:2006, Clause **12**, I/0 NI/1-6, I/7”.

13 Final examination

As cases of progressive smouldering undetected from the outside have been reported, immediately after completion of the test programme on the test specimen, dismantle and examine the test specimen for progressive smouldering (see **4.1**). If this is present, extinguish the test specimen and record that ignition has occurred for the relevant ignition source. For safety reasons ensure that all smouldering has ceased before the test assembly is left unattended.

14 Test report

The test report shall state:

- a) either 1) or 2) as appropriate for the test(s) carried out:
 - 1) “The following test results relate only to the ignitability of the combination of upholstery composites (BS 5852:2006, Clause **11**) under the particular conditions of test stated; they are not intended as a means of assessing the full potential fire hazard of the materials or products in use”; or
 - 2) “The following test results relate only to the ignitability of the complete item (BS 5852:2006, Clause **12**) under the particular conditions of test stated; they are not intended as a means of assessing the full potential fire hazard of the materials or products in use”;
- b) the identification and construction of the test specimens;

NOTE 1 Unless a report contains sufficient information about the materials and constructions tested to identify them precisely and any flame-retardant treatment, it might be of only limited value to a third party such as a purchaser, fire authority or trading standards officer.

- c) the ignition sources applied;
- d) if a complete item of furniture is being tested, the positions tested;
- e) for each ignition source applied, the test result, ignition or non-ignition, expressed as an ignitability performance in accordance with **11.5** or **12.6** as appropriate;
- f) the clause, number and date of this British Standard, i.e. BS 5852:2006, Clause **11** (upholstery composite) or BS 5852:2006, Clause **12** (complete item).

The test report shall contain details of any features of the test specimens or procedures that might have affected the results. Such features are:

- 1) conditioning of the test sample, including details of water soak and drying procedure if carried out, and of any pre-treatment required by performance specifications and/or upholstered furniture safety regulations (see Note to **10.1**);
- 2) design details of complete items of furniture;
- 3) details of ignition, if recorded;
- 4) special features of burning, e.g. melting, dripping, charring, development of flames from smouldering;
- 5) times of major events, e.g. ignition of test specimens, cover splitting, extinction;
- 6) number of tests carried out.

NOTE 2 An example of a test report layout is shown in Annex F.

Annex A (informative) **Guidance for test operators**

A.1 Selection of timber for crib construction

Timber is a natural material and the density of a given species can vary considerably within a given sample or tree and between different tree growing areas. The dimensions and density of timber also vary with moisture content.

The density of the *Pinus silvestris* specified for the wooden crib is nominally 500 kg/m³ conditioned wood [see 9.3.1a)].

The dimensional tolerances theoretically allow for a density variation of about $\pm 13\%$ for the thicker timber and $\pm 30\%$ for the thinner section timber, but it is difficult to use all this variation in practice because the dimensional tolerances given for the stick section are not much greater than normal cutting tolerances. It is possible to prepare strips of wood to the upper tolerance and to adjust the strip thickness according to its density but this requires the use of a planing machine, accurate wood working techniques and conditioned wood. Some adjustment is possible because of the greater length tolerances.

In practice, the simplest way of obtaining cribs of the required dimensions and mass is by mixing sticks of specified dimensions but of different mass. Classifying the sticks into three or possibly five categories on a mass basis prior to crib building is recommended.

Satisfactory results can be obtained by cutting strips of wood to the required section and then grading the long strips on the basis of mass per unit length (see Table A.1). Individual sticks can then be cut without the need to check each individual stick. This requires that conditioned wood is used and that the strips are cut uniformly to the required section. The presence of knots and resin pockets will increase the apparent density of the timber and needs to be allowed for. However, knots and resin pockets can affect the burning behaviour of the crib and should therefore be avoided wherever possible.

It is advisable to check a number of individual sticks using a go, no-go gauge and by weighing to assess the uniformity of the timber and of the cutting operation before cutting large numbers of sticks. Some adjustment of stick mass is possible by altering the stick length (within the specification limits).

Conditioning can be a lengthy process and it is advisable to store the timber in a warm, dry place and to pre-cut the timber into thin planks before conditioning.

Table A.1 **Suggested grading of sticks on mass/unit length basis**

Nominal stick size			Grade				
Square section mm	Length mm	Mass g	Heavy g/cm	Medium heavy g/cm	Medium g/cm	Medium light g/cm	Light g/cm
6.5	40	0.85	>0.23	0.215 to 0.23	0.2 to 0.215	0.185 to 0.2	<0.185
6.5	80	1.7	>0.23	0.215 to 0.23	0.2 to 0.215	0.185 to 0.2	<0.185
12.5	80	6.3	>0.88	0.82 to 0.88	0.76 to 0.82	0.70 to 0.76	<0.70

A.2 Cleaning of rig

It is important that the rig is kept clean to ensure that the test specimens do not become contaminated with the residues left from earlier tests. It is particularly important that the hinged bar is kept clean. This may be facilitated by using a hinge bar that can be removed to minimize contamination as well as to aid cleaning. A hinge bar that is held in place by split pins has been found to be acceptable.

Cleaning the test rig can be done with solvents or by burning the residues off the rig. Care needs to be taken to ensure that the rig does not become distorted when removing residues by burning. When solvents are used care should be taken to prevent test specimens becoming contaminated with the solvents. Normal safety procedures should be followed particularly when flammable and/or toxic solvents are being used.

NOTE Attention is drawn to the Control of Substances Hazardous to Health Regulations 2002 [4].

Annex B (informative) Guidance for designers and specifiers

B.1 Limitation of Clause 11 ignitability rig tests

In conjunction with BS EN 1021-1:1994 and BS EN 1021-2:1994, Clause 11 of this standard describes methods for examining the ignitability, in defined circumstances, of an assembly of upholstered composites for seating. These materials are combined in a way intended to be generally representative of their end use in upholstered seating, and the flaming ignition sources are selected so that most can be related to sources such as burning matches and sheets of burning newspaper, while the other sources are of intensities selected to provide a regularly stepped range of source severity.

Thus the potential ignitability of using a particular cover, filling and interliner in combination can be assessed and this will allow the development of specifications concerned with the limit of ignitability by flaming sources that is considered acceptable for various circumstances of use of the furniture. However, there are two important limitations.

- a) The tests are concerned only with ignitability, and any controls of fire hazard also have to take into account other aspects of fire performance such as rate of fire development, heat output, rate and quantity of smoke production and toxic gas evolution. Ideally, any attempts to reduce ignitability ought not to affect adversely these other properties.

- b) The tests measure only the ignitability of a combination of materials used in upholstered seating and not of a particular finished item of furniture incorporating these materials. They give only an indication of the ignition behaviour of the finished item of furniture. This limitation occurs because design features and trimmings of the furniture can greatly affect its fire properties; any ignitability tests of a piece of furniture would therefore need to be carried out on the actual item and not on component materials or mock-ups. For this reason, Clause 12 describes the ignitability testing of complete items of furniture. However, limited information on ignitability more specifically related to an intended design may be obtained as indicated in B.2 and B.3.

B.2 Specification of ignition performance using Clause 11

When specifying the minimum ignitability requirement for a piece of furniture it should be borne in mind that a typical seating unit might well incorporate several different combinations of cover and filling; for example, in the seat, back and arms. It is important that each cover/filling combination is tested separately and that all meet the requirements.

NOTE It is the responsibility of the purchaser, fire authority or law enforcement officer to ensure that this is the case.

B.3 Use of modified procedures to test design features

This standard describes laboratory tests for an assembly of materials which will give general guidance on the ignitability of finished furniture, but where more specific information is required, e.g. for tip-up seats or in critical areas of end use, the principles may be applied to complete items or sub-assemblies of furniture or to suitably modified test assemblies, some examples of which are given below. In such cases the sources described in Clause 8 and Clause 9 may be applied at positions which, as a general rule, correspond to those where the hazard of ignition occurs in use.

Example 1. If a chair were to have a gap between the seat and back cushions the placement of ignition sources in the angle of the test apparatus would be inappropriate. Instead, face ignition, where the sources are placed on the horizontal and vertical surfaces, would be more meaningful.

Example 2. The use of different materials in a back and seat of a chair may be reproduced in the test, two different cover fabrics being joined by sewing or stapling behind the hinge bar.

Example 3. The test apparatus may be used to model the junction of any vertical and horizontal surfaces so that both arm and back constructions, if different, may be tested separately in conjunction with the seat.

Example 4. If in the final design a loose cushion is to be placed on an upholstered seat platform, additional traps are produced between the loose cushion and the surrounding upholstery. This may be examined using the rig by constructing a loose cushion of the appropriate materials measuring (450 ± 5) mm \times (225 ± 5) mm \times (75 ± 2) mm to be placed on the top of the horizontal surface of the normally assembled test arrangement. In order to check the additional traps, smouldering sources in particular need to be placed beneath the loose cushion.

If the behaviour of these special test assemblies is such as to indicate that a failure which has occurred on a rig test cannot occur in practice, the results for the more realistic test should be given greater consideration in assessing the performance of an actual piece of furniture.

B.4 Use of modified test procedures in comparative testing

Another way in which this test principle might be used is to give information about individual materials to be used in a combination. For example, the ability of a cover material to provide protection against ignition can be indicated by testing it in combination with a substrate of known flammability.

B.5 Reproducibility and repeatability of tests

Interlaboratory tests have established that the reproducibility and repeatability of the test methods are good. However, in some circumstances there might be inherent variability in the materials used in a combination which can affect ignitability. This is particularly important where the ignitability of a combination is borderline between two sources since differences in result can then easily occur on different test occasions.

This might not be serious when evaluating ignitability by progressively increasing the size of the ignition source until failure occurs because the result will always be close to the true value. For example, if the true ignitability is borderline between sources 4 and 5, the result of any one test will be either 4 or 5. However, this effect will be much more significant when the test is used for specification purposes. From a single test (in duplicate as described) of a composite, to determine whether it passed a particular prescribed level, it would not be possible to form a conclusion with certainty. For example, if a specification required resistance to ignition source 5, from a pass result at this level it would not be possible to conclude whether the result was reliable and to be expected every time, or whether true ignitability was borderline 4/5 and there would be an even chance of another test failing. It is thus most important that specifiers using this method should define the amount of testing they require to regard the result as properly representative for their particular purposes.

Annex C (informative) **Gas flow control**

It is essential that the rate of supply of the butane to the burner tube conforms to the flow rates specified.

Some difficulties have been reported with the supply and measurement of the butane, particularly where the butane cylinder has, of necessity, to be stored in an environment cooler than the defined test conditions and/or some distance from the test rig.

In these cases, and other situations where difficulties occur, it is important that there should be sufficient length of tubing inside the controlled environment (10 °C to 30 °C) to ensure that the gas equilibrates to the required temperature before flow measurement. One way to assist this is to pass the gas (before flow measurement) through a metal tube immersed in water maintained at 25 °C so that flow corrections for temperature variations can be avoided.

Great care also needs to be exercised with the measurement and setting of the flow rate of the gas. Direct reading flowmeters, even those obtained with a direct gas calibration, need to be checked when initially installed and also at regular intervals during testing by a method capable of accurately measuring the absolute gas flow at the burner tube. One way of doing this is to connect the burner tube with a short length of tubing (about 7 mm inside diameter) to a soap bubble flowmeter, such that the upward passage of a soap film meniscus in a glass tube of calibrated volume (e.g. a burette) over a known period of time gives an absolute measurement of the flow.

Annex D (informative) **Suggested methods of crib construction**

NOTE A simple way to ensure that the core of the crib is correct is to build the crib around a former. A smooth hardwood block nominally 27 mm × 27 mm × 100 mm is suitable for cribs 4 and 5 and the inner cribs of sources 6 and 7. A hardwood block nominally 55 mm × 55 mm × 150 mm is suitable for cribs 6 and 7. The sticks are glued around the block and the block removed before the glue sets. For example, crib 5 is made by gluing 18 sticks together, removing the block, fixing lint in place on top and then gluing on the remaining two sticks.

D.1 Crib ignition source 4

Glue together eight sticks to form the main crib body. Stick one square of lint across the crib square section and then glue on the remaining two sticks to form the base (see Figure 6).

D.2 Crib ignition source 5

Glue together 18 sticks to form the main crib body. Stick one square of lint across the crib square section and then glue on the remaining two sticks to form the base (see Figure 7).

D.3 Crib ignition source 6

Glue together six of the main crib sticks to form the main crib body to make construction A. Glue together the eight ignition crib sticks and the two ignition crib base sticks; stick one square of lint across the ignition crib square section and then glue the remaining two main crib sticks to make construction B [see Figure 8a)]. When the adhesive is set invert construction B and glue it to construction A [see Figure 8b)].

D.4 Crib ignition source 7

Glue together 16 of the main crib sticks to form the main crib body to make construction A. Glue together the six ignition crib sticks plus two of the ignition crib base sticks to form the ignition crib body; stick one square of lint across the ignition crib square section and then glue on the remaining two ignition crib base sticks to form the ignition crib; glue on the remaining two main crib sticks to make construction B [see Figure 9a)]. When the adhesive is set, invert construction B and glue it to construction A [see Figure 9b)].

Annex E (normative) Water soaking and drying procedure

E.1 Reagents

E.1.1 Water. A supply of water with a degree of hardness of 8 dH to 10 dH (80 mg/l to 100 mg/l CaO). If the water is harder than 10 dH, demineralized water shall be added until the required degree of hardness is achieved. The quantity of demineralized water added to 1 l of water with a degree of hardness $D(>10 \text{ dH})$ shall be $(D - 9)/9 \text{ l}$.

EXAMPLE 1 To 5 l water with a degree of hardness 13.4 dH, add $5 \times (13.4 - 9)/9 = 2.44 \text{ l}$ demineralized water to obtain 7.44 l water with a degree of hardness of 9 dH.

If the water is softer than 8 dH, salts shall be added in order to increase the hardness. Two solutions shall be prepared:

- a) *Solution I:* dissolve 3.91 g calcium chloride ($\text{CaCl}_2 \cdot 6\text{H}_2\text{O}$) in 1 l demineralized or distilled water.
- b) *Solution II:* dissolve 3.00 g sodium bicarbonate (NaHCO_3) in 1 l demineralized or distilled water.

The quantity of these two solutions added to 1 l water of a degree of hardness of $D(<8 \text{ dH})$ shall be $12.2 (9 - D) \text{ ml}$.

EXAMPLE 2 To 10 l water with a degree of hardness 7.0 dH, add $10 \times 12.2 (9 - 7) = 244 \text{ ml}$ of solution I and an equal amount of solution II to obtain 10.488 l water with a degree of hardness of 9 dH.

E.1.2 Wetting agent. Any non-ionic wetting agent.

NOTE The exact nature of this reagent is not critical.

E.2 Apparatus

E.2.1 Flat-bottomed dish of sufficient size to enable the test specimens to be completely immersed.

E.3 Specimens

Use sufficient cover material to permit subsequent preparation of the required number of test specimens of the dimensions specified in Figure 10.

Each different fabric shall be water soaked separately.

NOTE Depending on the dimensions of the flat-bottomed dish (E.2.1) the specimen might need to be folded.

E.4 Procedure

Using a liquor ratio (sample mass:water mass) of 1:20, completely immerse each specimen in water (E.1.1) containing 0.5 g/l of non-ionic wetting agent (E.1.2) in the flat-bottomed dish (E.2.1) at an initial temperature of (40 ± 1) °C. Ensure that the specimen remains completely immersed.

After 30 min, remove the specimen. If it has been folded during immersion, refold it before rinsing. Rinse the specimen in the water (E.1.1) using a liquor ratio of 1:20 for 2 min, then dry the specimen by hanging it vertically from the shorter edge nearest to the cut-outs so that it is not in contact with other specimens, materials or surfaces. After drying, condition the specimen in accordance with 10.1.2.

NOTE Drying time will vary with different covers but a time of 48 h in indoor ambient conditions is expected to be satisfactory for most fabrics.

Annex F (informative) Example of test report layout

Figure F.1 shows an example of a test report layout.

Figure F.1 Example of test report layout

Testing authority															
Test number Sample reference Company/customer Date															
British Standard BS 5852:2006 Clause 11 (composites)/Clause 12 (complete items) ^{A)} Ignition sources used															
Test conditions				Period h			Temperature °C			Relative humidity %		Volume m ³			
Conditioning of test specimen including details of water soak and drying if carried out															
Conditioning of ignition sources															
Testing temperature and r.h.															
Testing enclosure (fume cupboard/room)															
Identification and construction of test specimens and any pre-treatment details															
Report															
The following test results relate only to the ignitability of the combination of upholstery composites (Clause 11) ^{A)} or complete item (Clause 12) ^{A)} under the particular conditions of test. They are not intended as a means of assessing the full potential fire hazard of the materials or products in use.															
Ignition source		Ignition/ non-ignition		Duration of			Extent of damage to horizontal component			Extent of damage to vertical component		Reason for failure		Comments and observations	
Number	Position			Ignition source min	Flames min	Smoke min	Width mm	Length mm	Depth mm	Width mm	Depth mm				
^{A)} Delete as applicable.															

Bibliography

Standards publications

For dated references, only the edition cited applies. For undated references, the latest edition of the referenced document (including any amendments) applies.

BS 4250, *Specification for commercial butane and commercial propane*

BS 6807, *Methods of test for assessment of the ignitability of mattresses, divans and bed bases with primary and secondary sources of ignition* ²⁾

BS 7176, *Specification for resistance to ignition of upholstered furniture* ²⁾

Other publications

- [1] GREAT BRITAIN. Furniture and Furnishings (Fire) (Safety) Regulations 1988. London: HMSO.
- [2] GREAT BRITAIN. Furniture and Furnishings (Fire) (Safety) (Amendment) Regulations 1989. London: HMSO.
- [3] GREAT BRITAIN. Furniture and Furnishings (Fire) (Safety) (Amendment) Regulations 1993. London: HMSO.
- [4] GREAT BRITAIN. Control of Substances Hazardous to Health Regulations 2002. London: The Stationery Office.
- [5] GREAT BRITAIN. Health and Safety at Work etc. Act 1974. London: HMSO.

²⁾ Referred to in the foreword only.

BSI – British Standards Institution

BSI is the independent national body responsible for preparing British Standards. It presents the UK view on standards in Europe and at the international level. It is incorporated by Royal Charter.

Revisions

British Standards are updated by amendment or revision. Users of British Standards should make sure that they possess the latest amendments or editions.

It is the constant aim of BSI to improve the quality of our products and services. We would be grateful if anyone finding an inaccuracy or ambiguity while using this British Standard would inform the Secretary of the technical committee responsible, the identity of which can be found on the inside back cover.

Tel: +44 (0)20 8996 9000. Fax: +44 (0)20 8996 7400.

BSI offers members an individual updating service called PLUS which ensures that subscribers automatically receive the latest editions of standards.

Buying standards

Orders for all BSI, international and foreign standards publications should be addressed to Customer Services. Tel: +44 (0)20 8996 9001.

Fax: +44 (0)20 8996 7001. Email: orders@bsi-global.com. Standards are also available from the BSI website at <http://www.bsi-global.com>.

In response to orders for international standards, it is BSI policy to supply the BSI implementation of those that have been published as British Standards, unless otherwise requested.

Information on standards

BSI provides a wide range of information on national, European and international standards through its Library and its Technical Help to Exporters Service. Various BSI electronic information services are also available which give details on all its products and services. Contact the Information Centre. Tel: +44 (0)20 8996 7111. Fax: +44 (0)20 8996 7048. Email: info@bsi-global.com.

Subscribing members of BSI are kept up to date with standards developments and receive substantial discounts on the purchase price of standards. For details of these and other benefits contact Membership Administration. Tel: +44 (0)20 8996 7002. Fax: +44 (0)20 8996 7001. Email: membership@bsi-global.com.

Information regarding online access to British Standards via British Standards Online can be found at <http://www.bsi-global.com/bsonline>.

Further information about BSI is available on the BSI website at <http://www.bsi-global.com>.

Copyright

Copyright subsists in all BSI publications. BSI also holds the copyright, in the UK, of the publications of the international standardization bodies. Except as permitted under the Copyright, Designs and Patents Act 1988 no extract may be reproduced, stored in a retrieval system or transmitted in any form or by any means – electronic, photocopying, recording or otherwise – without prior written permission from BSI.

This does not preclude the free use, in the course of implementing the standard, of necessary details such as symbols, and size, type or grade designations. If these details are to be used for any other purpose than implementation then the prior written permission of BSI must be obtained.

Details and advice can be obtained from the Copyright & Licensing Manager.

Tel: +44 (0)20 8996 7070. Fax: +44 (0)20 8996 7553.

Email: copyright@bsi-global.com.