

Fire detection and alarm systems for buildings —

Part 2: Specification for manual call points

UDC 696.6:614.842.43:654.924.5

Committees responsible for this British Standard

This British Standard was published under the direction of the Fire Standard Committee FSB/-. Its preparation was entrusted to Technical Committee FSB/12 upon which the following bodies were represented:

Association of Manufacturers Allied to the Electrical and Electronic Industry (BEAMA)

British Fire Protection Systems Association Ltd.

Chartered Institution of Building Services

Chief and Assistant Chief Fire Officers' Association

Department of Health and Social Security

Department of the Environment (Building Research Establishment, Fire Research Station)

Department of the Environment (Housing and Construction)

Department of the Environment (PSA)

Electrical Contractors' Association

Electrical Installation Equipment Manufacturers' Association (BEAMA)

Fire Insurers' Research and Testing Organization (FIRTO)

Fire Offices' Committee

Fire Protection Association

Greater London Council

Home Office

Institution of Electrical Engineers

Institution of Fire Engineers

Ministry of Defence

Post Office

Royal Institute of British Architects

Telecommunication Engineering and Manufacturing Association (TEMA)

The following bodies were also represented in the drafting of the standard, through subcommittees and panels:

Department of Trade (Marine Division)

Electricity Supply Industry of England and Wales

This British Standard, having been prepared under the direction of the Fire Standards Committee, was published under the authority of the Board of BSI and comes into effect on 28 February 1983.

© BSI 12-1998

The following BSI references relate to the work on this standard:

Committee reference FSM/12
Draft for comment 81/12947

ISBN 0 580 12962 4

Amendments issued since publication

Amd. No.	Date of issue	Comments
4685	November 1985	
5085	March 1986	Indicated by a sideline in the margin

Contents

	Page
Committees responsible	Inside front cover
Foreword	ii
<hr/>	
1 Scope	1
2 Definitions	1
3 Test requirements	1
4 Construction and principle of operation	2
5 Operation	4
6 Access to live parts	4
7 Insulation resistance and dielectric strength	4
8 Electrical contact material	5
9 Durability of electrical contacts and contact mechanism	6
10 Vibration	7
11 Corrosion	7
12 Impact	9
13 Dry heat	9
14 Damp heat steady state	9
15 Cold	10
16 Ingress of water	10
<hr/>	
Appendix A Apparatus for tests for non-operation and operation	11
Appendix B Impact test apparatus	12
Appendix C Corrosion test apparatus	14
<hr/>	
Figure 1 — Test circuit for measurement of contact resistance	6
Figure 2 — Corrosion test apparatus (10 L)	8
Figure 3 — Apparatus for test for non-operation	11
Figure 4 — Apparatus for test for operation	12
Figure 5 — <i>Deleted</i>	12
Figure 6 — Impact test apparatus	13
<hr/>	
Table 1 — Test schedule	1
Table 2 — Conditioning severities of vibration	7
<hr/>	
Publications referred to	Inside back cover
<hr/>	

Foreword

This Part of this British Standard, prepared under the direction of the Fire Standards Committee, is a revision of BS 5364-1:1977 which is now withdrawn. It is published as a new part of BS 5839 in accordance with the Technical Committee's intentions stated in the foreword of BS 5839-1.

This part of this standard specifies requirements and tests for manual call points and their mounting boxes intended for use with electrical fire alarm systems.

The purpose of a manual call point is to enable a person discovering a fire to initiate the operation of a fire alarm system and thereby to give a warning at the earliest practical moment so that the appropriate measures can be taken.

It is important for manual call points to be readily identifiable and simple to understand and use without the need to read elaborate instructions, so that anyone discovering a fire is able to use a call point without previous familiarity with it. This standard, however, requires a method of operation with a clearly irreversible effect, i.e. the direct breaking of a frangible element, which is intended to deter misuse.

It is equally important that manual call points remain reliable in operation when subjected to the environmental hazards likely to be met in situ, e.g. the effects of corrosion, dust, vibration and damp, and that they be properly installed and maintained. Information on installation and servicing of electrical fire alarm systems is given in BS 5839-1.

The requirements of this part of this standard are intended to ensure similarity in the method of use and reliability of operation. The method of operation tested within this part of this standard, i.e. hitting or pressing a breakable element forming part of the front face, is considered to be the most suitable method for general application in the UK.

The major changes in this revision are as follows.

- a) The environmental tests of BS 2011 have been introduced as far as possible.
- b) Requirements for creepage distances and clearances have been omitted pending the work of IEC/TC 79, Alarm Systems, of the International Electrotechnical Commission and CENELEC/TC 79, Alarm Systems, of the European Committee for Electrotechnical Standardization.

It has been assumed in the drafting of this part of this standard that the execution of its provisions is entrusted to appropriately qualified and experienced people, for whose guidance it has been prepared.

The requirement limiting the distance of travel of particles of the frangible element when a call point was operated was deleted by amendment for the following reasons:

- 1) the method of test was not repeatable or practical;
- 2) the requirement induced designs in opposition to the philosophy and principle of operation of the devices.

This part of this standard calls for the use of substances, apparatus and procedures that may be injurious to health if adequate precautions are not taken. It refers only to technical suitability and does not absolve the user from the legal obligations relating to health and safety at any stage. For example, suitable precautions should be taken during the electrical tests of this part of this standard against electrical shock, and, in any of the tests against the possibility that frangible elements may fracture and broken pieces may be ejected from a call point. It should be noted that these examples are not exhaustive.

A British Standard does not purport to include all the necessary provisions of a contract. Users of British Standards are responsible for their correct application.

Compliance with a British Standard does not of itself confer immunity from legal obligations.

Summary of pages

This document comprises a front cover, an inside front cover, pages i to iv, pages 1 to 14, an inside back cover and a back cover.

The BSI copyright notice displayed in this document indicates when the document was last issued.

Sidelining in this document indicates the most recent changes by amendment.

1 Scope

This part of BS 5839 specifies the requirements and methods of test for manual call points for use in electrical fire alarm systems. It also specifies requirements for mounting boxes for use with manual call points.

NOTE The titles of the publications referred to in this part of this standard are listed on the inside back cover.

2 Definitions

For the purposes of this part of this standard, the following definitions apply.

2.1

manual call point

a device intended for the manual initiation of an alarm of fire in an electrical fire alarm system, operated by the breaking by hitting or pressing of a frangible element forming part of the front face

2.2

mounting box

a box not necessarily specifically designed for containing a manual call point but into which a manual call point is designed to be fitted

2.3

specimen

a manual call point together with any necessary mounting box, intended to be tested in accordance with this part of this standard, whether or not normally supplied with the call point

2.4

normal condition

the condition in which breakage of the frangible element would be expected to cause an alarm to be given by the associated control and indicating equipment

2.5

frangible element

a single or laminated material, part or all of which will irreversibly fracture under pressure or impact

3 Test requirements

NOTE See the foreword concerning safety precautions.

3.1 General

The specimens shall be tested and/or inspected according to the schedule given in Table 1 and shall comply with the clauses listed.

3.2 Provision for test

The following shall be provided for use in the tests given in clauses 4 to 16:

- 10 specimens;
- 50 additional frangible elements;
- data as required by 4.1.9 if this is not marked on the manual call points;
- mechanical and electrical production drawings with details of parts, dimensions, materials and finishes and specification of the mounting box (for reference).

3.3 Test schedule

The specimens shall be randomly numbered 1 to 10 by the testing organization.

The tests on each specimen shall be carried out in the order listed in Table 1 from top to bottom.

Table 1 — Test schedule

Test/inspection	Clause	Specimen number										
		1	2	3	4	5	6	7	8	9	10	
Construction and principle of operation	4	X										
Operation	5		X	X	X	X	X	X	X	X	X	X
Access to live parts	6		X									
Insulation resistance and dielectric strength	7			X								
Electrical contact material	8				X							
Durability	9					X						
Vibration	10						X					
Corrosion	11							X				
Impact	12								X			
Dry heat	13									X		
Damp heat	14										X	
Cold	15										X	
Ingress of water ^a	16											X

^a Applicable if the manual call point is specified by the manufacturer as being suitable for use out-of-doors (see 4.1.9).

3.4 Mounting arrangements

If a specimen is mounted for test it shall be mounted in accordance with the manufacturer's instructions on a rigid backing board by its normal means of attachment. If these instructions describe more than one method, then the method considered to be most unfavourable shall be chosen for each test.

3.5 Associated equipment

During the tests in clauses 5, 9, 10, 12, 13, 14, 15 and 16 the specimens under test shall be connected to monitoring equipment capable of monitoring all the functions of the manual call point.

3.6 Voltages, currents and frequencies for testing

Voltages, currents and frequencies applied to a specimen shall be within the ranges specified by the manufacturer in 4.1.9, except where a particular value is specified in a method of test.

3.7 Atmospheric conditions for tests

The range of atmospheric conditions for carrying out tests and measurements, unless otherwise specified in this part of this standard, are as follows:

temperature:	15 °C to 35 °C;
relative humidity:	45 % to 75 %;
air pressure:	86 kPa to 106 kPa.

3.8 Tolerances

If a specific tolerance or limit is not specified in a method of test, a tolerance of $\pm 5\%$ shall be applied

4 Construction and principle of operation

4.1.1 General. When test in accordance with 4.2 the specimen shall comply with 4.1.2 to 4.1.9.

4.1.2 Front face. When mounted as specified in 3.4, the front face shall be parallel to the backing board. The front face shall have an area not less than 5 000 mm² and shall contain a frangible element having an exposed area of not less than 1 600 mm² with its maximum dimension not greater than 2.5 times its minimum dimension.

4.1.3 Colour. The outside of the specimen shall be coloured to give an approximate colour match to colour no. 537 signal red, of BS 381C:1980 on at least 90 % of any part of the sides, top and bottom which is visible when mounted in accordance with the manufacturer's instructions (see 4.1.9) and on an area of at least 50 % of the front face of the manual call point.

4.1.4 Principle of operation. The manual call point shall be operated by the single action of breaking a frangible element. This shall cause the device to change to and remain in its alarm initiating state until the frangible element is replaced. Any device to retain frangible element fragments shall not detract from the principle of a single and direct action for the breaking of the frangible element; nor shall such a device project beyond the front face.

4.1.5 Terminals for external conductors. The manual call point shall be provided with terminals for connecting external conductors. A terminal shall be so designed that it clamps a conductor between metal surfaces with sufficient contact pressure and without damage to the conductor.

Each terminal shall allow the connection of any conductor having a nominal cross-sectional area between 0.4 mm² and 1.5 mm². If the manufacturer specifies a larger conductor size (see 4.1.9), the terminal shall also accept any conductor having a nominal cross-sectional area between 1.5 mm² and that larger size. Unless declared in the manufacturer's data that the manual call point is suitable only for use with one conductor per terminal connection, the terminals shall be duplicated or another method shall be provided for making effective connection of two conductors without allowing the two conductors to touch each other. The method used shall be such that effective connection shall be made to any two conductors (not necessarily equal) having nominal cross-sectional areas between 0.4 mm² and 1.5 mm², and if the manufacturer specifies a larger conductor size (see 4.1.9), the terminals shall also accept any conductors having nominal cross-sectional areas between 1.5 mm² and that larger size, so that the connection between the conductors is made through the manual call point and not by direct contact between the conductors.

4.1.6 Provision for external conductors. The space for the conductors inside the manual call point and/or mounting box shall be adequate to allow the conductors to be easily introduced and connected. The manual call point and/or its mounting box shall be provided either with conduit entries or knock-outs to allow the connection of at least two conduits or with cable entries, knock-outs, or glands to provide entries for at least two mineral-insulated metal sheathed cables. If knock-outs, holes or cable entries are not provided, each manual call point and/or its mounting box shall be provided with a template or some other means to indicate where holes for glands, cable or conduit entry are to be made.

If the mounting box is designed for the use of specific sizes of conduit, these shall be declared (see 4.1.9). The dimensions of knock-outs in boxes for the reception of conduit shall be the nominal conduit size +0.25 mm with a tolerance of -0.0, +0.50 mm.

NOTE This does not exclude the provision of entries of forms other than circular.

Any knock-out or removable plug shall remain in place when subjected to a force of 45 N applied to either side.

Knock-outs in mounting boxes shall be so located that locknuts or bushes when clamped in position seat satisfactorily against the walls of the box.

4.1.7 Provision for earthing. If the manual call point is intended for use at voltages in excess of extra low voltage it shall have suitable means for providing earth continuity between external circuits connected to it. All exposed metal parts, (that is metal parts that can be touched with the test finger in the test described in clause 6), of a manual call point intended for use at voltages in excess of extra low voltage shall be in effective electrical contact with an earth terminal, unless they are adequately insulated and protected in such a way that they cannot come into contact with live conductors

4.1.8 Test facilities. The manual call point shall contain means for routine tests of its operation. Such means shall not require breaking the frangible element, and shall be so designed that use of a tool is necessary to give the alarm during the test procedure. Breakage of the frangible element shall be simulated mechanically, e.g. by enabling the frangible element to be moved to a position so that the manual call point operates. If during the test operation, the state of any internal circuit of the manual call point is changed, other than by the means involved in normal operation of the manual call point, then the manual call point shall incorporate a facility for initiating an automatic indication in the event of any such circuit not returning to its proper state when the manual call point is restored to normal.

4.1.9 Marking and data. The manual call point shall be indelibly marked with the number of this part of this standard, i.e. BS 5839-2¹⁾, and with sufficient information to identify the type, the manufacturer or supplier as appropriate, and the maximum operating voltage and current, and frequency.

The method of operation shall be clearly indicated by a concise, permanent inscription including the word "fire", e.g. "FIRE: BREAK GLASS".

The manual call point shall be marked or supplied with appropriate instructions for installation, connection and testing. These instructions shall include at least:

- a) the maximum and minimum operating voltages (V_{\max} , V_{\min}) and frequency;
- b) the maximum current (I_{\max}) together with any limitations on source impedance;
- c) the maximum contact resistance or contact resistance range for each pair of contacts when the contacts are closed (R_{\max});
- d) the terminal identification;
- e) the maximum size of cable conductor that the terminals will accept;
- f) the specification of the mounting box if needed and not supplied with the manual call point;
- g) the suitability or otherwise of the manual call point for installation out-of-doors;
- h) any restriction or otherwise on the connection of more than one conductor per terminal connection;

¹⁾ Marking BS 5839-2 on or in relation to a product is a claim by the manufacturer that the product has been manufactured in accordance with the requirements of the standard. The accuracy of such a claim is therefore solely the manufacturer's responsibility. Enquiries as to the availability of third party certification to support such claims should be addressed to the Director, Quality Assurance Division, British Standards Institution, Maylands Avenue, Hemel Hempstead, Herts HP2 4SQ in the case of certification marks administered by BSI or to the appropriate authority for other certification marks.

- i) information on any internal device of which the contact resistance cannot be measured directly without making extra connections;
- j) the sizes of conduit if the manual call point or mounting box is designed for specific sizes;
- k) the facilities provided for routine testing and the method of operation;
- l) the method of mounting.

If the information given in a) to l) is not marked on the manual call point, the manual call point shall be marked "Connect only in accordance with the manufacturer's instructions" or equivalent wording.

4.2 Method of test

Test the specimen for compliance with 4.1.2 to 4.1.9 by inspection. Where required in 4.1.6, for each knock-out or removable plug, apply a force of 45 N to the centre of each side in turn. Apply the force in a plane perpendicular to the test surface, using a mandrel with a 6 mm diameter end.

5 Operation

5.1 Requirements

When tested in accordance with 5.2 the specimen shall comply with the following:

- a) when tested in accordance with 5.2.3 the frangible element shall not break or crack and no alarm signal shall be given;
- b) when tested in accordance with 5.2.4 the frangible element shall break and an alarm signal shall be given;
- c) the specimen shall return to its normal condition when the frangible element is replaced;
- d) the routine test facilities shall not be impaired.

5.2 Method of test

5.2.1 Principle. The test involves the application of a force, which shall not cause the specimen to operate, followed by an impact, which shall cause the specimen to operate.

5.2.2 Apparatus, as described in appendix A.

5.2.3 Procedure for test for non-operation. Mount the specimen in its normal condition as specified in 3.4. Use the apparatus described in A.1 and apply a horizontal force to the part of the exposed frangible element considered to be the weakest. Apply the force at a rate not exceeding 5 N/s until it reaches 25 +5, -0 N. Hold it steady for 5 s, then release it again at a rate not exceeding 5 N/s.

5.2.4 Procedure for test for operation. Use the apparatus described in A.2 and subject the specimen to an impact delivered, in a horizontal direction, to a point within 5 mm of the centre of the exposed face of the frangible element. Produce the impact by allowing the centre of the brass ball to fall through a vertical distance of 350 +0, -10 mm. Allow the ball to strike the specimen once only.

5.2.5 Reinstatement. Reinstate the specimen by replacing the frangible element with an unbroken one taken at random from the additional frangible elements submitted.

5.2.6 Routine test facilities. Test the routine test facilities by operating the routine test procedure in accordance with the manufacturer's instructions.

6 Access to live parts

6.1 Requirement

When tested in accordance with 6.2 the specimen shall be deemed to comply with this clause if the test finger cannot touch any conducting component in an electric circuit other than that directly connected to an earth terminal.

6.2 Method of test

6.2.1 Apparatus. Test finger A complying with BS 3042.

6.2.2 Procedure. Apply the test finger, with the least force necessary, in every possible position to the specimen, mounted as specified in 3.4, first in its normal condition and then with its frangible element removed and with any cover etc., required to be open to replace the element, open.

7 Insulation resistance and dielectric strength

7.1 Requirements

When tested in accordance with 7.2 the specimen shall comply with the following:

- a) the insulation resistance shall be greater than 1 M Ω for each measurement specified in 7.2.2;
- b) no breakdown or flashover shall be observed during the test of 7.2.3.

7.2 Method of test

7.2.1 Preconditioning. Mount the specimen as specified in 3.4 on a metal plate and bring it to a temperature of $t +4, -0$ °C where t is any convenient temperature between 20 °C and 30 °C. Precondition the specimen in an atmosphere with a temperature of $t \pm 1$ °C and a relative humidity of 93 ± 2 % for a period of 48 h for manual call points for indoor use only and 168 h for manual call points intended for use out-of-doors.

Carry out the measurements and test described in 7.2.2 and 7.2.3 at the end of this period or within 15 min in an atmosphere with a temperature of $t + 4, -0$ °C.

7.2.2 Measurement of insulation resistance.

Measure the insulation resistance between the opposite poles of each set of switch contacts while they are open and between all terminals provided for external conductors (except earthing conductors) linked together and any metal part insulated therefrom (including earthing terminals and the metal mounting plate). Measure the insulation resistance with a d.c. voltage of approximately 500 V applied and carry out the measurement at least 1 min after application of the voltage.

If it is necessary to operate the manual call point to carry out this test, do this either as described in 5.2.4, or by the means described in 4.1.8.

7.2.3 Test of dielectric strength. Test the dielectric strength by applying an a.c. voltage V_t of substantially sine-wave form, having a frequency between 40 Hz and 60 Hz, between all terminals for external conductors (except earthing conductors) linked together and any metal part insulated therefrom (including earthing terminals and the metal mounting plate). Apply the voltage at a rate of between 100 V/s and 500 V/s and maintain it at V_t for 60 ± 5 s.

The value of the test voltage V_t shall be:

- a) 500 V for manual call points with a maximum operating voltage V_{max} less than 50 V;
- b) 1 500 V for manual call points with a maximum operating voltage V_{max} of more than 50 V.

8 Electrical contact material

8.1 Requirement

When tested in accordance with 8.2 the specimen shall be deemed to comply with this clause if the contact resistances do not exceed the values R_{max} specified by the manufacturer (see 4.1.9) for each pair of contacts.

8.2 Method of test

8.2.1 General. The test procedure shall be as described in BS 2011-2.1Kc:1977 and as follows.

8.2.2 Apparatus, complying with that described in BS 2011-2.1Kc:1977.

8.2.3 Preconditioning. Connect the specimen to be tested to a suitable electrical source and load so that the contacts switch at the maximum electrical ratings specified by the manufacturer, i.e. open-circuit voltage = V_{max} , and closed-circuit current = I_{max} . Make the contacts switch ten times.

8.2.4 Initial measurements. Measure the contact resistance(s) with contacts closed. If it is necessary to operate the manual call point to achieve this state, do this as described in 5.2.4 or by the means described in 4.1.8.

Connect the specimen in series with an ammeter and a resistance of value R_s to a low resistance d.c. power supply having an output voltage of V_{min} . Connect a further pair of wires to the terminals of the manual call point and to a voltmeter having a resistance of not less than $100 R_s$ (see Figure 1)

Calculate the contact resistance by dividing the measured voltage across the contacts by the current passing through them (V_c/I_c) and record the value. If the manual call point has no requirement on the polarity of the supply, reverse the polarity of the supply and obtain a second value of contact resistance. Record the mean of the two values.

Calculate the mean of the two values for the two polarities and take the result to be the resistance of the contacts.

If the manual call point switch is fitted internally with some device (e.g. for fault monitoring for short circuits in the zone wiring by the fire alarm control equipment) in such a way that the contact resistance cannot be measured directly, then it is permitted for extra connections to be brought out from the manual call point to allow the direct measurement of the contact resistance for this specific test. It is essential that such connections do not affect the performance of the manual call point in this test in any other respect.

8.2.5 State of the specimen during the conditioning. If it was necessary for the specimen to be operated during the measurements of 8.2.4, reinstate the specimen as described in 5.2.5.

Mount or suspend the specimen, in the apparatus, in such a way that it is not shielded from the test atmosphere.

Do not connect the specimen to supply or monitoring equipment during the test.

8.2.6 Conditioning. Do not clean the specimen before or after the conditioning period.

Expose the specimen to the conditioning atmosphere specified in BS 2011-2.1Kc:1977 for 21 days.

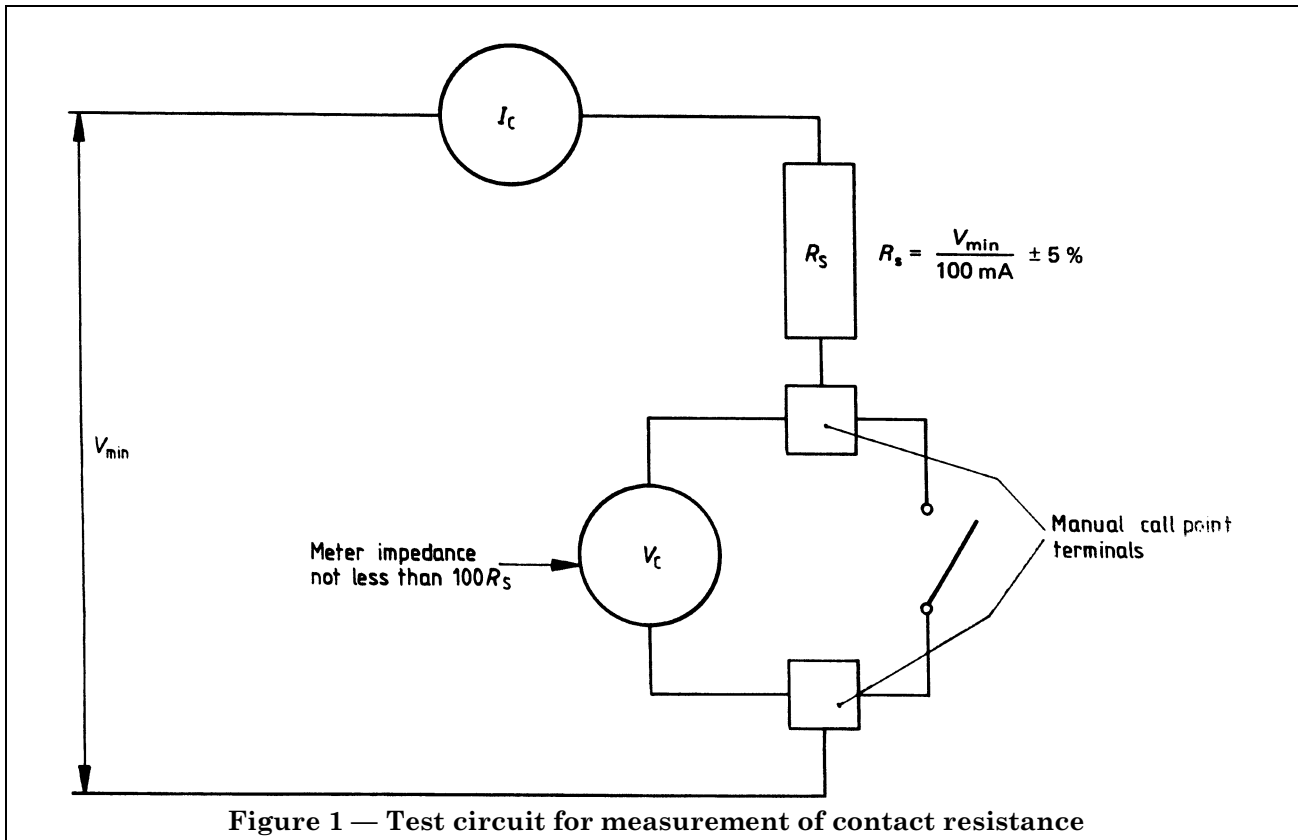

8.2.7 Final measurements. Remove the specimen from the chamber and store it under the conditions specified in 3.7 for not less than 2 h.

Measure the contact resistance(s) again as described in 8.2.4 within 24 h of the end of the recovery period

9 Durability of electrical contacts and contact mechanism

9.1 Requirements

When tested in accordance with 9.2 the specimen shall comply with the following

- the contacts shall operate correctly throughout the test;
- the contact resistance(s) shall not exceed the values R_{\max} specified by the manufacturer (see 4.1.9) for each pair of contacts.

9.2 Method of test

9.2.1 Apparatus. Suitable means shall be provided to drive the manual call point mechanism mechanically, with approximately simple harmonic motion and without any undue discontinuity, such that the electrical contacts operate in a normal manner at a rate of 10 to 15 operations per minute. Any latching mechanism that prevents rapid operation of the manual call point shall be disabled for the purpose of this test.

The test apparatus shall provide a means of electrically monitoring each operation of the contacts during the test, while the contacts are switching the maximum electrical rating specified by the manufacturer, i.e. open-circuit voltage = V_{\max} and closed-circuit current = I_{\max} .

9.2.2 Procedure

9.2.2.1 Initial measurements. Measure the contact resistance(s) as described in 8.2.4.

9.2.2.2 Conditioning. Operate each set of electrical contacts provided for initiating an alarm 10 000 times while switching their maximum electrical rating as specified in 9.2.1.

9.2.2.3 Final measurements. Measure the contact resistance(s) as described in 8.2.4.

10 Vibration

10.1 Requirements

When tested in accordance with **10.2** the specimen shall comply with the following:

- a) no alarm signal shall be given and no electrical or mechanical failure shall occur during the functioning test;
- b) no damage apart from the fracture of the frangible element shall be apparent after the endurance test;
- c) the specimen shall comply with clause **5** after the functioning test and the endurance test.

10.2 Method of test

10.2.1 General. The test procedure shall be as described in BS 2011-2.1Fc:1983, except for the conditioning severities which shall be as given in **10.2.4**.

The specimen shall be exposed to the conditioning vibration in each of three perpendicular planes in turn. One of the vibration axes shall be perpendicular to the plane of mounting of the specimen.

10.2.2 Apparatus. Vibration apparatus complying with clause **4** of BS 2011-2.1Fc:1983 and capable of producing the vibration frequencies and amplitudes given in Table 2.

10.2.3 State of the specimen during conditioning. Mount the specimen on the test fixture as described in **3.4**. During the functioning test conditioning, connect the specimen, in its normal condition, to suitable supply and monitoring equipment (see **3.5**). Do not connect the specimen to such equipment during the endurance test conditioning.

10.2.4 Functioning and endurance test conditioning. Apply the conditioning severities given in Table 2.

Table 2 — Conditioning severities of vibration

	Functioning test	Endurance test
Frequency range, Hz	10 to 150	10 to 150
Cross over frequency f_c , Hz	12	12
Acceleration amplitude (above f_c), m/s^2	9.81	29.43
Displacement amplitude (below f_c), mm	± 1.5	± 5.0
Number of axes	3	3
Number of sweeps per axis	1	20

10.2.5 Functioning test. Monitor the specimen during the functioning test conditioning period to detect any alarm signal. After the functioning test conditioning, subject the specimen to the tests described in clause **5**.

10.2.6 Endurance test. After the endurance test conditioning, remove the specimen from the test fixture and inspect it for damage. Reinststate the specimen as described in **5.2.5** and subject it to the tests described in clause **5**.

11 Corrosion

11.1 Requirements

When tested in accordance with **11.2** the specimen shall comply with the following:

- a) the specimen shall comply with clause **5**;
- b) there shall be no visible moisture in the specimen other than in areas separated from the operating mechanism by a waterproof division. If all or part of such a division is formed by a flexible or elastomeric seal, the chamber containing the operating mechanism shall be opened for inspection for visible moisture.

11.2 Method of test

11.2.1 Apparatus, as described in appendix C.

NOTE A suitable apparatus is shown in Figure 2.

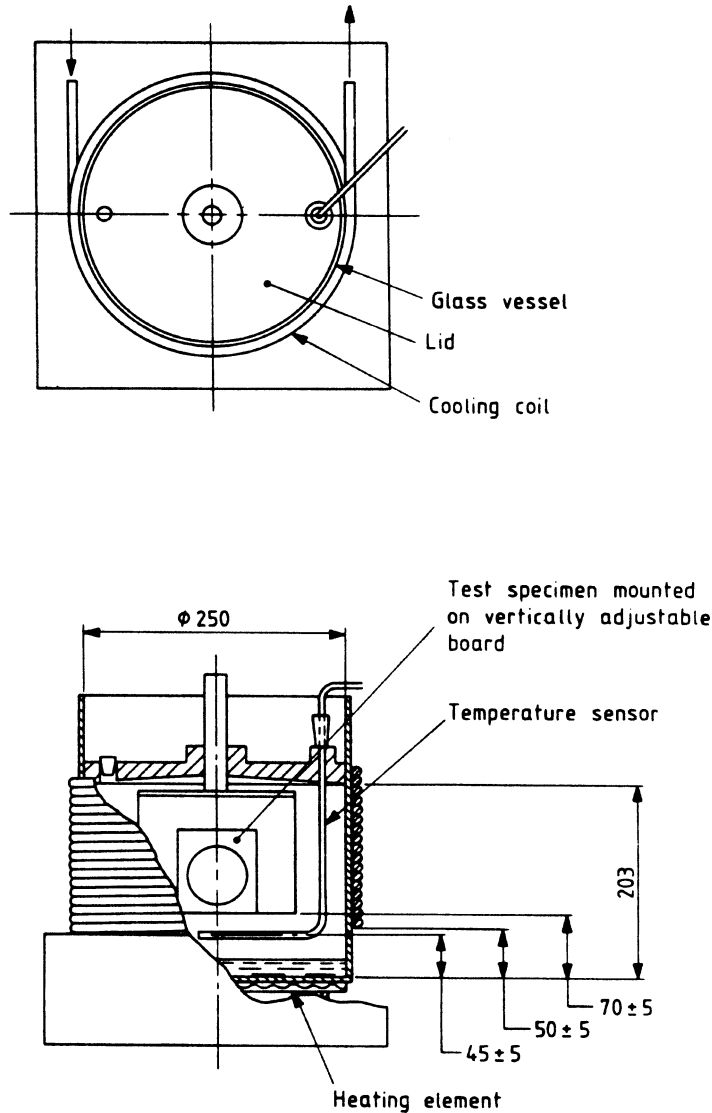

NOTE. All dimensions are in millimetres. Untoleranced dimensions are approximate.

Figure 2 — Corrosion test apparatus (10 L)

11.2.2 Mounting procedure. Connect not less than 115 mm of 1.38 mm diameter single core untinned copper wire to each terminal of the specimen which is mounted in its normal position on a non-corrodible backing board in the apparatus so that its lowest point is 70 ± 5 mm above the bottom of the vessel. Provide a guard to prevent drops of liquid from falling onto the upper surface of the manual call point.

11.2.3 Conditioning. Maintain the temperature near the specimen at 45 ± 3 °C by means of the heater and temperature controller, and run water through the cooling device at a speed sufficient to maintain the temperature of the outflow below 30 °C.

Produce the atmosphere by placing in the beaker a solution made up by adding 40 g of sodium thiosulphate ($\text{Na}_2\text{S}_2\text{O}_3 \cdot 5\text{H}_2\text{O}$) to 1 000 mL of water. Suspend the specimen in the beaker and add acid, consisting of 156 mL of normal sulphuric acid (H_2SO_4) per litre of aqueous solution, either as 20 mL twice daily or continuously at a rate of 40 mL of acid per 24 h.

Remove the specimen after eight days and empty and clean the beaker. Put a further 40 g of sodium thiosulphate dissolved in 1 000 mL of water in the beaker, replace the specimen and produce and maintain the corrosive atmosphere as before for a further eight days. Remove the specimen and allow it to dry naturally for seven days in an atmosphere with a temperature not exceeding 30 °C and a relative humidity not exceeding 70 %.

11.2.4 Final measurements and inspection. Subject the specimen to the tests described in clause 5.

Open the specimen and examine it for presence of moisture.

12 Impact

12.1 Requirements

When tested in accordance with 12.2 the specimen shall comply with the following:

- a) no alarm signal shall be given during the conditioning period;
- b) the specimen shall comply with clause 5.

12.2 Method of test

12.2.1 Apparatus. A suitable apparatus is given in appendix B.

12.2.2 State of specimen during conditioning. Mount the specimen as specified in 3.4 and connect it, in its normal condition, to suitable supply and monitoring equipment (see 3.5).

12.2.3 Conditioning. Subject the specimen to an impact of 2.7 J delivered in a horizontal direction, at a velocity of 1.8 ± 0.15 m/s, by a swinging hammer having a hard aluminium head made from aluminium alloy Al–Cu4SiMg complying with ISO/R 209-1971, solution treated and precipitation treated condition, with a plane impact face at an angle of 60° to the horizontal when in the striking position.

Choose the azimuthal direction of impact relative to the manual call point as most likely to impair the normal functioning of the manual call point and strike the blow with the centre of the impact face.

12.2.4 Measurements during conditioning. Monitor the specimen during the conditioning period to detect any spurious alarm signal.

12.2.5 Final measurements. Subject the specimen to the tests described in clause 5.

13 Dry heat

13.1 Requirements

When tested in accordance with 13.2 the specimen shall comply with the following:

- a) no alarm signal shall be given during the conditioning period except as permitted in clause 5;
- b) the specimen shall comply with clause 5 after the operations described in 13.2.5 and in 13.2.6 have been carried out.

13.2 Method of test

13.2.1 General. The test procedure shall be as described in test Bb of BS 2011-2.1B:1977 and as follows.

13.2.2 Apparatus, complying with that described in test Bb of BS 2011-2.1B:1977.

13.2.3 State of specimen during conditioning. Mount the specimen as specified in 3.4 and connect it, in its normal condition, to suitable supply and monitoring equipment (see 3.5).

13.2.4 Conditioning. Apply the following severity of conditioning:

temperature:	70 ± 2 °C;
duration:	16 h.

13.2.5 Measurements during conditioning. Monitor the specimen during the conditioning period to detect any spurious alarm signal.

At the end of the conditioning period but before the recovery period, subject the specimen to the tests described in clause 5 except that reinstatement shall take place after the recovery period.

13.2.6 Final measurements. After the recovery period and reinstatement, subject the specimen to the tests described in clause 5.

14 Damp heat steady state

14.1 Requirements. When tested in accordance with 14.2 the specimen shall comply with the following:

- a) no alarm signal shall be given during the conditioning period except as permitted in clause 5;
- b) the specimen shall comply with clause 5 after the operations described in 14.2.5 and in 14.2.6 have been carried out.

14.2 Method of test

14.2.1 General. The test procedure shall be as described in BS 2011-2.1Ca:1977 and as follows.

14.2.2 Apparatus, complying with that described in BS 2011-2.1Ca:1977.

14.2.3 State of the specimen during conditioning. Mount the specimen as specified in 3.4 and connect it, in its normal condition, to suitable supply and monitoring equipment (see 3.5).

14.2.4 Conditioning. Apply the following severity of conditioning:

temperature:	40 ± 2 °C;
relative humidity:	93_{-3}^{+2} %;
duration:	10 days.

14.2.5 Measurements during conditioning. Monitor the specimen during the conditioning period to detect any spurious alarm signal.

At the end of the conditioning period but before the recovery period, subject the specimen to the tests described in clause 5 except that reinstatement shall take place after the recovery period.

14.2.6 Final measurements. After the recovery period and reinstatement, subject the specimen to the tests described in clause 5.

15 Cold

15.1 Requirements

When tested in accordance with 15.2 the specimen shall comply with the following:

- no alarm signal shall be given during the conditioning period except as permitted in clause 5;
- the specimen shall comply with clause 5 after the operations described in 15.2.5 and in 15.2.6 have been carried out.

15.2 Method of test

15.2.1 General. The test procedure shall be as described in test Ab of BS 2011-2.1A:1977 and as follows.

15.2.2 Apparatus, complying with that described in test Ab of BS 2011-2.1A:1977.

15.2.3 State of specimen during conditioning. Mount the specimen as specified in 3.4 and connect it, in its normal condition, to suitable supply and monitoring equipment (see 3.5).

15.2.4 Conditioning. Apply the following severity of conditioning:

temperature:	-10 ± 2 °C;
duration:	16 h.

15.2.5 Measurement during conditioning. Monitor the specimen during the conditioning period to detect any spurious alarm signal. At the end of the conditioning period but before the recovery period, subject the specimen to the tests described in clause 5 except that reinstatement shall take place after the recovery period.

15.2.6 Final measurements. After the recovery period and reinstatement, subject the specimen to the tests described in clause 5.

16 Ingress of water

16.1 Requirements

When tested in accordance with 16.2 the specimen shall comply with the following:

- no alarm shall be initiated during the spraying period;
- the insulation resistance shall comply with 7.1a);
- the specimen shall comply with clause 5.

16.2 Method of test

16.2.1 General. The test procedure shall be as described in 8.3 of BS 5490:1977 for the hand held spray device.

16.2.2 Apparatus, complying with that described in 8.3 of BS 5490:1977 except that the hand held spray shown in Figure 5 of BS 5490:1977 is used.

16.2.3 State of the specimen during conditioning. Mount the specimen on a vertical metal mounting plate with at least 300 mm of free surface around the specimen. Connect the specimen as recommended by the manufacturer for installation out-of-doors, in its normal condition, to suitable supply and monitoring equipment (see 3.5).

16.2.4 Conditioning. Subject the specimen to the water spray for 5 min.

16.2.5 Measurements during conditioning. Monitor the specimen during the conditioning period to detect any spurious alarm signals.

16.2.6 Measurements after conditioning. Immediately after spraying is stopped, disconnect the specimen from any equipment. Measure the insulation resistance as specified in 7.2.2. Subject the specimen to the tests specified in clause 5.

Appendix A Apparatus for tests for non-operation and operation

A.1 Apparatus for test for non-operation

The test apparatus is capable of applying a horizontal force of 25 ± 5 , -0 N to the surface of the frangible element. The force is applied through a flat rubber surface of 15 ± 1 mm diameter having a hardness of 40 IRHD to 50 IRHD (international rubber hardness degrees) (see BS 903-A26).

Typical apparatus for the test for non-operation is shown in Figure 3

A.2 Apparatus for test for operation

The apparatus consists of a pendulum made up of a brass ball of mass 85 ± 1 g suspended from a light string arranged so that the ball strikes the frangible element of the specimen when the pendulum is hanging vertically. Typical apparatus is shown in Figure 4

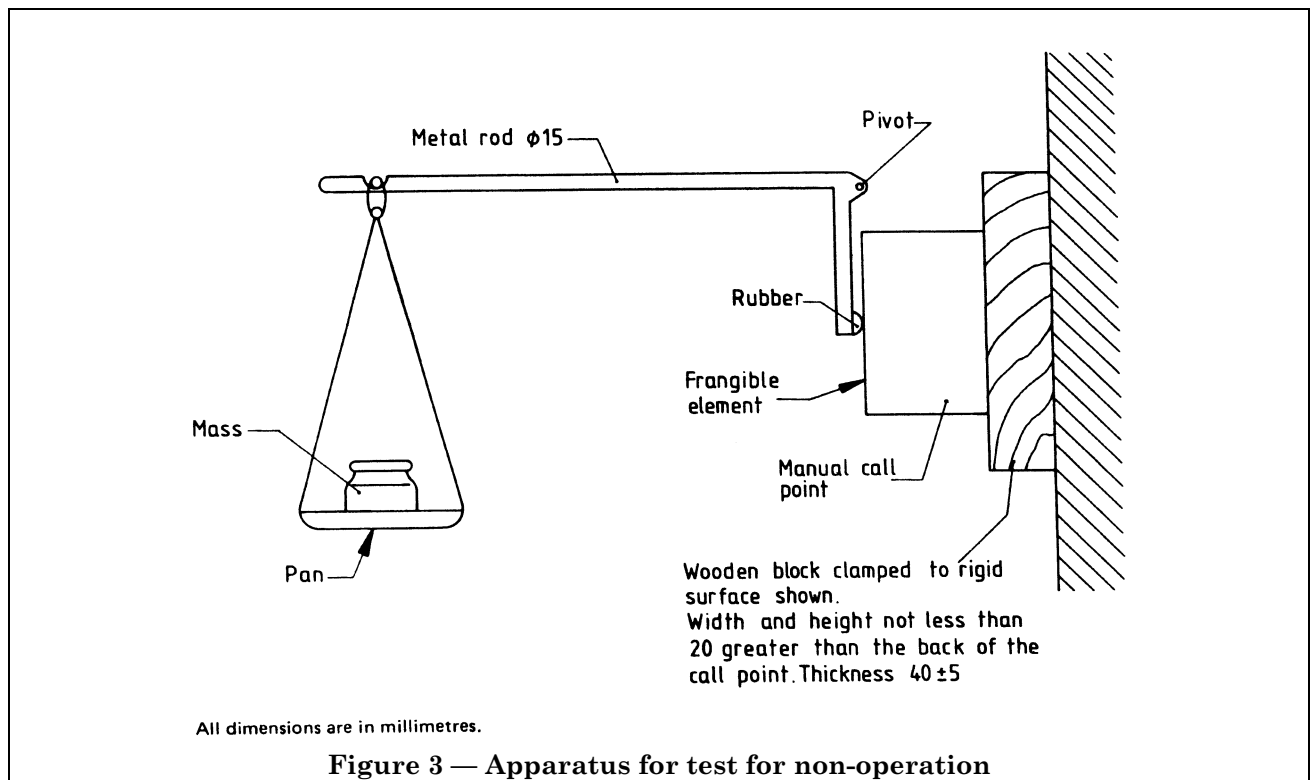

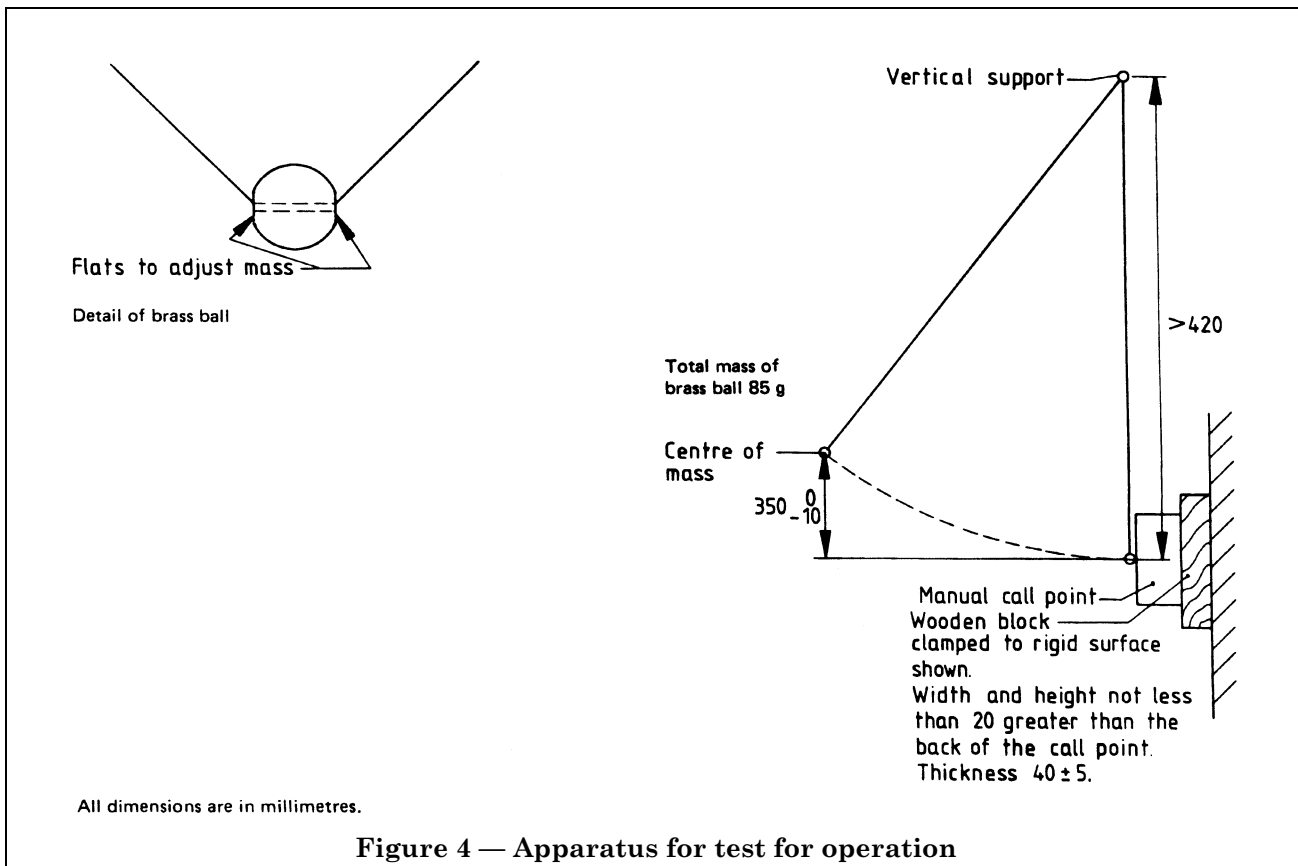

Figure 5. Deleted.

Appendix B Impact test apparatus

A suitable apparatus (see Figure 6) consists essentially of a swinging hammer comprising a rectangular section head with a chamfered impact face mounted on a tubular steel shaft. The hammer is fixed into a steel boss which runs on ball bearings on a fixed steel shaft mounted in a rigid steel frame, so that the hammer can rotate freely about the axis of the fixed shaft. The design of the rigid frame is such as to allow complete rotation of the hammer assembly when the manual call point and its backing board are not present.

All dimensions, except those for the mounting of the ball bearings, are subject to a tolerance of ± 0.5 mm.

The striker is 76 mm wide \times 50 mm deep \times 94 mm long (overall dimensions). It has a plane impact face chamfered at $60 \pm 1^\circ$ to the long axis of the head. The tubular steel shaft has an outside diameter of 25 ± 0.1 mm with walls 1.6 ± 0.1 mm thick.

The striker is mounted on the shaft so that its long axis is at a radial distance of 305 mm from the axis of rotation of the assembly, the axes being mutually perpendicular. The central boss is 102 mm in outside diameter and 200 mm long and is mounted co-axially on the fixed steel pivot shaft, which is 25 mm in diameter. The precise diameter of the shaft will depend on the bearings used.

Diametrically opposite the hammer shaft are two steel counter balance arms, each 20 mm in outside diameter and 185 mm long, screwed into the boss so that a length of 150 mm protrudes. A counter balance weight is mounted on the arms so that its position can be adjusted to balance the weight of the striker and arm, as shown in Figure 6. On one end of the central boss a 12 mm wide \times 150 mm diameter aluminium alloy pulley is mounted and round this an inextensible cable is wound, one end being fixed to the pulley. The other end supports the operating weight.

The rigid frame also supports the rigid vertical backing board on to which the manual call point is mounted. The board is adjustable vertically so that the centre of the impact face of the hammer will strike the manual call point when the hammer is moving horizontally, as shown in Figure 6.

To operate the apparatus, the position of the manual call point and the backing board first is adjusted and the backing board is rigidly secured to the frame. The hammer assembly is then balanced carefully by adjustment of the counter balance weight with the operating weight removed. The hammer arm is then drawn back to the horizontal position ready for release and the operating weight is reinstated. On release of the assembly, the operating weight spins the hammer and arm through an angle of 270° to strike the manual call point. The mass of the operating weight for this arrangement equals $0.552/3 r$ kg, where r is the effective radius of the pulley in metres. This equals approximately 0.78 kg for a pulley radius of 75 mm.

Because 12.2 specifies a hammer velocity at impact of 1.8 ± 0.15 m/s, the mass of the hammer head needs to be reduced by drilling the back face sufficiently to obtain this velocity. It is estimated that a head of mass of about 0.79 kg is required to obtain the specified velocity, but this needs to be determined by trial and error.

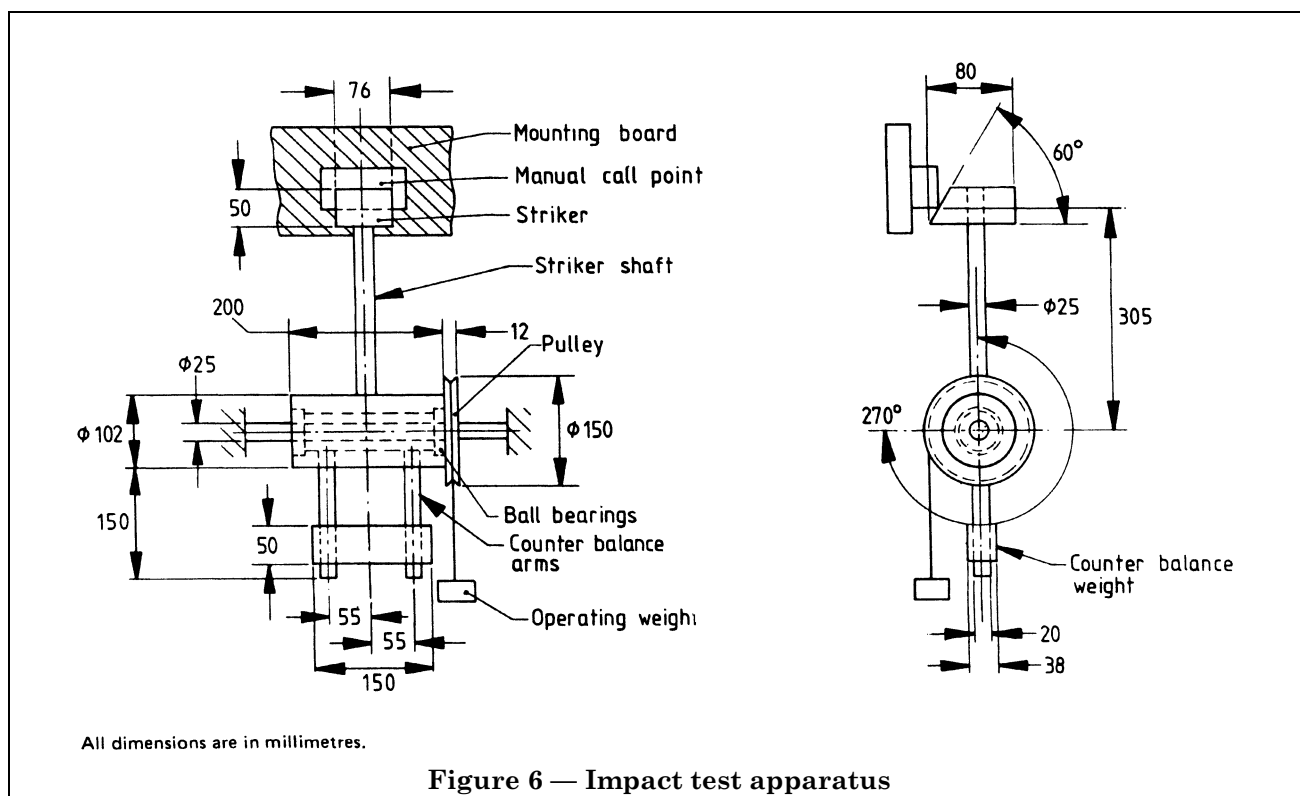

Appendix C Corrosion test apparatus

The corrosion test apparatus consists of a heat resistant glass vessel, of approximately 250 mm diameter, heated at the bottom by an electric heating element and cooled at the sides to within 50 ± 5 mm of the bottom by a water cooling coil. The vessel incorporates a corrosion resistant lid arranged to enclose a 10 L test volume. The temperature within the vessel is controlled by a temperature controller with its sensor arranged centrally 45 ± 5 mm above the bottom of the vessel.

A suitable apparatus is shown in Figure 2.

Publications referred to

BS 381C, *Specification for colours for identification, coding and special purposes.*

BS 903, *Methods of testing vulcanized rubber.*

BS 903-A26, *Determination of hardness.*

BS 2011, *Basic environmental testing procedures.*

BS 2011-2.1, *Tests.*

BS 2011-2.1A, *Tests A. Cold.*

BS 2011-2.1B, *Tests B. Dry heat.*

BS 2011-2.1Ca, *Test Ca. Damp heat, steady state.*

BS 2011-2.1Fc, *Test Fc. Vibration (sinusoidal).*

BS 2011-2.1Kc, *Test Kc. Sulfur dioxide test for contacts and connections.*

BS 3042, *Standard test fingers and probes for checking protection against electrical, mechanical and thermal hazard.*

BS 5490, *Specification for degrees of protection provided by enclosures.*

BS 5839, *Fire detection and alarm systems in buildings.*

BS 5839-1, *Code of practice for installation and servicing.*

ISO/R 209, *Composition of wrought products of aluminium and aluminium alloys — Chemical composition (per cent).*

BSI — British Standards Institution

BSI is the independent national body responsible for preparing British Standards. It presents the UK view on standards in Europe and at the international level. It is incorporated by Royal Charter.

Revisions

British Standards are updated by amendment or revision. Users of British Standards should make sure that they possess the latest amendments or editions.

It is the constant aim of BSI to improve the quality of our products and services. We would be grateful if anyone finding an inaccuracy or ambiguity while using this British Standard would inform the Secretary of the technical committee responsible, the identity of which can be found on the inside front cover. Tel: 020 8996 9000. Fax: 020 8996 7400.

BSI offers members an individual updating service called PLUS which ensures that subscribers automatically receive the latest editions of standards.

Buying standards

Orders for all BSI, international and foreign standards publications should be addressed to Customer Services. Tel: 020 8996 9001. Fax: 020 8996 7001.

In response to orders for international standards, it is BSI policy to supply the BSI implementation of those that have been published as British Standards, unless otherwise requested.

Information on standards

BSI provides a wide range of information on national, European and international standards through its Library and its Technical Help to Exporters Service. Various BSI electronic information services are also available which give details on all its products and services. Contact the Information Centre. Tel: 020 8996 7111. Fax: 020 8996 7048.

Subscribing members of BSI are kept up to date with standards developments and receive substantial discounts on the purchase price of standards. For details of these and other benefits contact Membership Administration. Tel: 020 8996 7002. Fax: 020 8996 7001.

Copyright

Copyright subsists in all BSI publications. BSI also holds the copyright, in the UK, of the publications of the international standardization bodies. Except as permitted under the Copyright, Designs and Patents Act 1988 no extract may be reproduced, stored in a retrieval system or transmitted in any form or by any means – electronic, photocopying, recording or otherwise – without prior written permission from BSI.

This does not preclude the free use, in the course of implementing the standard, of necessary details such as symbols, and size, type or grade designations. If these details are to be used for any other purpose than implementation then the prior written permission of BSI must be obtained.

If permission is granted, the terms may include royalty payments or a licensing agreement. Details and advice can be obtained from the Copyright Manager. Tel: 020 8996 7070.