

BS 5733:2010+A1:2014



BSI Standards Publication

General requirements for electrical accessories – Specification

bsi.

...making excellence a habit.™

Version correct as of 03/01/2015. (c) The British Standards Institution 2013 Licensed copy: Lee Shau Kee Library, HKUST. Version correct as of 03/01/2015. (c) The British Standards Institution 2013 Licensed copy: Lee Shau Kee Library, HKUST.

Publishing and copyright information

The BSI copyright notice displayed in this document indicates when the document was last issued.

© The British Standards Institution 2014
Published by BSI Standards Limited 2014

ISBN 978 0 580 83990 0

ICS 29.120.01

The following BSI references relate to the work on this standard:

Committee reference PEL/23

Drafts for comment 09/30202852 DC, 13/30288271 DC

Publication history

First published April 1979

Second edition, June 1995

Third (present) edition, July 2010

Amendments issued since publication

Date	Text affected
January 2014	A1. See Foreword

Contents

Foreword *iii*

1	Scope	1
2	Normative references	2
3	Terms and definitions	3
4	Classification	11
5	General requirements	12
6	Type testing	12
7	Rating	13
8	Marking	13
9	Dimensions	16
10	Clearances, creepage distances and solid insulation	16
11	Accessibility of live parts	20
12	Provision for earthing	23
13	Construction	25
14	Terminals and terminations	29
15	Screws, current-carrying parts and connections	41
16	Provisions for cables and cords	43
17	Resistance to ageing	47
18	Resistance to harmful ingress of water and resistance to humidity	47
19	Insulation resistance and electric strength	48
20	Temperature rise	49
21	Mechanical strength	52
22	Resistance to heat	62
23	Resistance of insulating material to abnormal heat, and to fire	65
24	<i>Clause deleted</i>	66
25	Resistance to excessive residual stresses and to rusting	66

Annexes

Annex A (informative)	Summary of tests on insulating parts of accessories	67
Annex B (normative)	Measurement of clearances and creepage distances	68
Annex C (normative)	Determination of the comparative tracking index (CTI) and proof tracking index (PTI)	72
Annex D (normative)	Relation between rated impulse withstand voltage, rated voltage and overvoltage category	73
Annex E (normative)	Pollution degree	73
Annex F (normative)	Impulse withstand voltage test	74
Bibliography		76

List of figures

Figure 1	Examples of pillar terminals	8
Figure 2	Examples of screw terminals and stud terminals	9
Figure 3	Examples of saddle terminals	10
Figure 4	Examples of lug terminals	10
Figure 5	Examples of a mantle terminal	11
Figure 6	Thread forming tapping screw	11
Figure 7	Thread cutting tapping screw	11
Figure 8	Gauge for checking non-accessibility through shutters	21
Figure 9	Apparatus for testing accessory enclosure fixing screws	23
Figure 10	Solid link for test on fuseclips	27
Figure 11	Arrangement for checking damage to conductors	31
Figure 11A	Arrangement for voltage drop test [New Figure]	40
Figure 12	Apparatus for flexing test	46

Figure 13 – General view of an example of impact test apparatus	54
Figure 14 – Constructional details of striking element	55
Figure 15 – Constructional details of mounting support for test samples	56
Figure 16 – Arrangement for mechanical strength test for portable accessories other than plugs or adaptors	57
Figure 17 – Tumbling barrel	58
Figure 18 – <i>Figure deleted</i>	63
Figure 19 – Apparatus for pressure test on portable accessories	64
Figure A.1 – Diagrammatic representation of the sequence of tests on insulating parts of accessories	67

List of tables

Table 1A – Minimum clearances for basic insulation	17
Table 1B – Minimum creepage distances for basic insulation	19
Table 1C – Withstand test voltages for solid insulation types	20
Table 2 – Conductors to be accommodated by terminals	30
Table 3 – Torque values for test of screws and nuts	31
Table 4 – Pull for terminal clamping test	32
Table 5 – Current for electrical and thermal stress test	37
Table 6 – Pull and torque tests for flexible cord and cable anchorages	44
Table 6A – Cross-sectional areas for copper conductors for temperature-rise test [New Table]	50
Table 7 – Multiplying factor for the temperature rise test	52
Table 8 – Torque for mechanical test on glands	61
Table B.1 – Minimum values of width “X”	68
Table D.1 – Rated impulse withstand voltage for accessories energized directly from the low voltage mains	73
Table F.1 – Test voltages for impulse withstand test	75

Summary of pages

This document comprises a front cover, an inside front cover, pages i to iv, pages 1 to 76, an inside back cover and a back cover.

Foreword

Publishing information

This British Standard is published by BSI Standards Limited, under licence for The British Standards Institution, and came into effect on 31 July 2010. It was prepared by Technical Committee PEL/23, *Electrical accessories*. A list of organizations represented on this committee can be obtained on request to its secretary.

Supersession

BS 5733:2010+A1:2014 supersedes BS 5733:2010, which is withdrawn.

Information about this document

BS 5733:2010 incorporated technical changes only. It did not represent a full review or revision of the standard, which will be undertaken in due course.

The principal changes from the previous edition were as follows.

- a) The standard now includes requirements for maintenance-free accessories.
- b) Clause **10** on clearances, creepage distances and solid insulation has been revised, and Clause **24** has been deleted.
- c) New Annexes B to F have been added.

The principal changes introduced by Amendment No. 1 are as follows.

- a) In **8.1** a new requirement has been specified for accessories incorporating screwless terminals.
- b) Amendments have been made to Tables 2, 5 and 6A.
- c) Amendments have been made to Clauses 14 and 19.

Text introduced or altered by Amendment No. 1 is indicated in the text by tags **A1** **A1**. Minor editorial changes are not tagged.

Hazard warnings

WARNING. This British Standard calls for the use of substances and/or procedures that can be injurious to health if adequate precautions are not taken. It refers only to technical suitability and does not absolve the user from legal obligations relating to health and safety at any stage.

Use of this document

It has been assumed in the preparation of this British Standard that the execution of its provisions will be entrusted to appropriately qualified and experienced people, for whose use it has been produced.

Presentational conventions

The provisions of this standard are presented in roman (i.e. upright) type. Its requirements are expressed in sentences in which the principal auxiliary verb is "shall".

Commentary, explanation and general informative material is presented in smaller italic type, and does not constitute a normative element.

Contractual and legal considerations

This publication does not purport to include all the necessary provisions of a contract. Users are responsible for its correct application.

Compliance with a British Standard cannot confer immunity from legal obligations.

1 Scope

1.1 This British Standard specifies requirements and tests to check the safety in normal use of electrical accessories which are not covered by other specific British Standards.

Such accessories are intended for use in household, commercial and light industrial premises where:

- the nominal supply voltage does not exceed 250 V a.c. single-phase, 50 Hz to 60 Hz or 250 V d.c.;
- the rated current of the accessory does not exceed 63 A.

Unless otherwise stated by the manufacturer, accessories conforming to this standard are intended for connection by cables or flexible cords conforming to BS 6004, BS 6007, BS 6500 or BS 7211.

1.2 This standard also covers:

- “plug-in” and other accessories in which electrical accessory components such as plug-pins, socket-contacts, switches, terminals, etc. are incorporated (see **5.1**);
- maintenance free accessories (see **3.31**).

1.3 Accessories conforming to this standard are suitable for use under the following conditions of service:

- an ambient temperature in the range -5 °C to +40 °C, the average value over 24 h not exceeding 25 °C;

NOTE 1 Under normal conditions of use, the available cooling air is subject to natural atmospheric variations of temperature and hence the peak temperature occurs only occasionally during the hot season, and on those days when it does occur, it does not persist for lengthy periods.

- a situation not subject to direct radiation from the sun or other source of heat likely to raise temperatures above the limits specified above;
- an altitude not exceeding 2 000 m above sea-level;
- an atmosphere not subject to excessive pollution by smoke, chemical fumes, or other abnormal conditions.

NOTE 2 Accessories conforming to this standard may be suitable for use in other conditions, subject to agreement between manufacturer and user. Information given in a manufacturer's catalogue may take the place of such an agreement.

1.4 Requirements for electromagnetic compatibility are not given, as accessories do not in themselves produce extraneous emissions, nor is their functioning affected by external emissions. Therefore no emission or immunity tests are necessary.

It should be noted that accessories containing active electronic components, other than luminous indicating devices, may be susceptible to, or emit, electromagnetic interference.

2 Normative references

The following referenced documents are indispensable for the application of this document. For dated references, only the edition cited applies. For undated references, the latest edition of the referenced document (including any amendments) applies.

BS 546, *Two-pole and earthing-pin plugs, socket-outlets and socket-outlet adaptors*

BS 646, *Specification for cartridge fuse-links (rated up to 5 amperes) for a.c. and d.c. service*

BS 1362, *Specification for general purpose fuse links for domestic and similar purposes (primarily for use in plugs)*

BS 1363-2, *13 A plugs, socket-outlets, adaptors and connection units – Part 2: Specification for 13 A switched and unswitched socket-outlets*

BS 1363-3:1995+A3:2007, *13 A plugs, socket-outlets, adaptors and connection units – Part 3: Specification for adaptors*

BS 1858:2002, *Electric cables – Accessories – Bitumen based filling compounds*

BS 6004, *Electric cables – PVC insulated non-armoured cables for voltages up to and including 450/750 V, for electric power, lighting and internal wiring*

BS 6007, *Electric cables – Single-core unsheathed heat resisting cables for voltages up to and including 450/750 V, for internal wiring*

BS 6500:2000+A3:2005, *Electric cables – Flexible cords rated up to 300/500 V, for use with appliances and equipment intended for domestic, office and similar environments*

BS 7211, *Electric cables – Thermosetting insulated, non-armoured cables for voltages up to and including 450/750 V, for electric power, lighting and internal wiring, and having low emission of smoke and corrosive gases when affected by fire*

BS EN 60064, *Tungsten filament lamps for domestic and similar general lighting purposes – Performance requirements*

BS EN 60068-2-6, *Environmental testing – Part 2-6: Tests – Test Fc: Vibration (sinusoidal)*

BS EN 60112:2003+A1:2009, *Method for the determination of the proof and the comparative tracking indices of solid insulating materials*

BS EN 60529, *Degrees of protection provided by enclosures (IP code)*

BS EN 60669-1:1999+A2:2008, *Switches for household and similar fixed electrical installations – Part 1: General requirements*

BS EN 60695-2-11:2001, *Fire hazard testing – Part 2-11: Glowing/hot-wire based test methods – Glow-wire flammability test method for end-products*

BS EN 60695-10-2:2003, *Fire hazard testing – Part 10-2: Abnormal heat – Ball pressure test*

BS EN 61032:1998, *Protection of persons and equipment by enclosures – Probes for verification*

3 Terms and definitions

For the purposes of this British Standard, the following terms and definitions apply.

- 3.1 accessory**
device associated with an electrical installation excluding the switchgear and cables
- 3.2 fixed accessory**
accessory intended to be connected to the fixed wiring of an installation
- 3.3 flush accessory**
fixed accessory intended for mounting substantially into a fixed surface, generally into a box
- 3.4 surface accessory**
fixed accessory intended for mounting onto a fixed surface
- 3.5 panel mounted accessory**
accessory intended for incorporation into equipment panels or electrical trunking and which depends upon such incorporation for its enclosure
- 3.6 portable accessory**
accessory not intended for fixed mounting and which may have provision for the connection of a flexible cord
- 3.7 rewirable accessory**
accessory so constructed that a cable or flexible cord may be fitted or replaced using general purpose tools
- 3.8 non-rewirable accessory**
accessory supplied complete with an appropriate cable or flexible cord but having no provision for replacement by the user and no provision for dismantling the accessory using general purpose tools
- 3.9 fused accessory**
accessory having provision, internally, for a replaceable cartridge fuse-link
- 3.10 infrequent use**
use of an accessory, which, although providing a means of connection between equipment and an electrical supply, is intended only to provide disconnection at infrequent intervals
- NOTE Examples include the following:*
- a) fuse holders;
 - b) clock connectors;
 - c) accessories requiring connection/disconnection by means of a tool;
 - d) accessories, the connection/disconnection of which is evidently intended to be infrequent, e.g. up to 100 operations during its life expectancy.
- 3.11 flush box**
device intended to be flush mounted into a fixed surface and having one open side to accept a flush accessory
- 3.12 surface box**
device intended to be mounted on a fixed surface and having one open side to accept a cover plate or a plate-mounted accessory

3.13 enclosure

complete outer protective case for an accessory

NOTE It may be integral with the complete assembly, as in a surface accessory or a portable accessory, or it may comprise a flush accessory mounted in a corresponding box.

3.14 plug

accessory having contacts designed to engage with the contacts of a socket-outlet, also incorporating means for the electrical connection and mechanical retention of flexible cables or cords

3.15 socket-outlet

accessory having socket-contacts designed to engage with the contacts of a plug and having terminals for the connection of cables or cords

3.16 shutter

movable part incorporated into a socket-outlet arranged to shield at least the live socket-outlet contacts automatically when the plug is withdrawn

3.17 adaptor

portable accessory having plug-pins, intended to engage with the contacts of a corresponding socket-outlet, and having socket-outlet contacts to accommodate one or more plugs

3.18 switch

device designed to make or break the current in one or more electric circuits

3.19 functional switch

switch not intended for safety isolating purposes

3.20 flex-outlet

unfused accessory intended for connection to the fixed wiring of an installation and having provision for the connection of a flexible cord to supply a fixed or stationary appliance

3.21 fused flex-outlet

flex-outlet incorporating a replaceable cartridge fuse-link to protect the flexible cord

NOTE A clock-connector is an example of a fused flex-outlet.

3.22 in-line cord connector

coupling device comprising a plug part and a socket part, both having provision for flexible cords which enter the respective accessories in an axial line coincident with the engagement axes of the two parts

3.23 terminal

means by which the user can make an electrical connection between the appropriate cable or flexible cord and the conducting parts of the accessory without the use of special tools

3.24 screw type terminal

terminal for the connection and subsequent disconnection of one conductor or the inter-connection of two or more conductors capable of being disconnected, the connection being made directly or indirectly by means of screws or nuts

3.25 pillar terminal

terminal with screw clamping in which the conductor is inserted into a hole or cavity, where it is clamped under the end of the screw or screws

NOTE 1 The clamping pressure may be applied directly by the end of the screw or through an intermediate clamping member to which pressure is applied by the end of the screw.

NOTE 2 Examples of pillar terminals are shown in Figure 1.

3.26 stud terminal

terminal with screw clamping in which the conductor is clamped under a nut

NOTE 1 The clamping pressure may be applied directly by a suitably shaped nut or through an intermediate part, such as a washer, a clamping plate or an anti-spread device.

NOTE 2 Examples of stud terminals are shown in Figure 2.

3.27 saddle terminal

terminal with screw clamping in which the conductor is clamped under a saddle by means of two or more screws or nuts

NOTE Examples of saddle terminals are shown in Figure 3.

3.28 lug terminal

screw terminal or a stud terminal, designed for clamping a cable lug or bar by means of a screw or nut

NOTE Examples of lug terminals are shown in Figure 4.

3.29 mantle terminal

terminal with screw clamping in which the conductor is clamped against the base of a slot, in a threaded stud, by means of a nut

NOTE 1 The conductor is clamped against the base of the slot by a suitably shaped washer under the nut, by a central peg if the nut is a cap nut, or by equally effective means for transmitting the pressure from the nut to the conductor within the slot.

NOTE 2 Examples of mantle terminals are shown in Figure 5.

3.30 screwless terminal

connecting device for the connection and subsequent disconnection of either:

- a) a rigid (solid or stranded) or flexible conductor; or
- b) the interconnection of two conductors capable of being disconnected,

without special preparation of the conductor concerned other than removal of insulation

NOTE The connection may be made directly or indirectly by one of several methods, e.g. springs, or angled, eccentric or conical parts.

3.31 maintenance free accessory

accessory which does not require further inspection, testing or maintenance after installation in a circuit, and which incorporates screwless terminals (see 14.5) and cable clamps to secure any associated cables

- 3.32 cable clamp**
accessory or part of a component to grip the cable to provide strain relief and absorb mechanical stress which would otherwise be transmitted to the termination
- 3.33 termination**
method of making an electrical connection between the appropriate cable or flexible cord and the conducting part of the accessory using special purpose tools
NOTE Special purpose tools are used in processes such as soldering, welding or crimping.
- 3.34 live parts**
current-carrying parts of an accessory and those metal parts in contact with them during normal use
NOTE Metal parts of the earthing circuit are not considered to be live parts.
- 3.35 accessible external surface**
surface of an accessory which can be touched by test probe 11 of BS EN 61032:1998 when the accessory is properly assembled and correctly wired, and is carrying current as in normal use
- 3.36 type test**
test or a series of tests made on a type test sample, for the purpose of checking conformity of the design of a given product to the requirements of the relevant standard
- 3.37 type test sample**
sample consisting of one or more similar units provided by the manufacturer or responsible vendor for the purpose of a type test
- 3.38 ambient temperature**
temperature in the room or area in which a type test is conducted, measured in the same horizontal plane as the accessory under test, at a distance of approximately 1 m from the accessory and in a position not adversely affected by other heat sources nor by cooling air currents
- 3.39 rated current**
current assigned to the accessory by the manufacturer
- 3.40 rated voltage**
voltage assigned to the accessory by the manufacturer
- 3.41 rough-use plug**
plug designed to withstand severe mechanical handling
NOTE Rough-use plugs are identified by additional marking in accordance with 8.1c). They are not intended for gross misuse. For instance, a plug should not be withdrawn from a socket-outlet by pulling on the attached flexible cord.
- 3.42 thread-forming tapping screw**
tapping screw having an uninterrupted thread which, by screwing in, forms a thread by displacing material
NOTE An example of a thread-forming tapping screw is shown in Figure 6.
- 3.43 thread-cutting tapping screw**
tapping screw having an interrupted thread which, by screwing in, makes a thread by removing material
NOTE An example of a thread-cutting tapping screw is shown in Figure 7.

- 3.44 lighting distribution unit**
assembly of more than one outlet specifically designated for the connection of luminaires contained within an enclosure; the outlets having female contacts designed to engage with the contacts of a male connector
- 3.45 basic insulation**
insulation applied to live parts to provide basic protection against electric shock
- NOTE Basic insulation does not necessarily include insulation used exclusively for functional purposes.*
- 3.46 supplementary insulation**
independent insulation applied in addition to basic insulation, in order to provide protection against electric shock in the event of failure of basic insulation
- 3.47 reinforced insulation**
single insulation system applied to live parts, which provides a degree of protection against electric shock equivalent to double insulation under the conditions specified in the relevant standard
- 3.48 functional insulation**
insulation between conductive parts which is necessary only for the proper functioning of the equipment
- 3.49 class I**
method of protection against electric shock which does not rely on basic insulation only, but which includes means for the connection of exposed-conductive-parts to a protective conductor in the fixed wiring of the installation
- 3.50 normal use**
use of an accessory for the purpose for which it was made, and in the manner intended by the manufacturer
- 3.51 resilient material**
material having the inherent capability of regaining, or substantially regaining, its original form when deforming loads are removed

Figure 1 Examples of pillar terminals

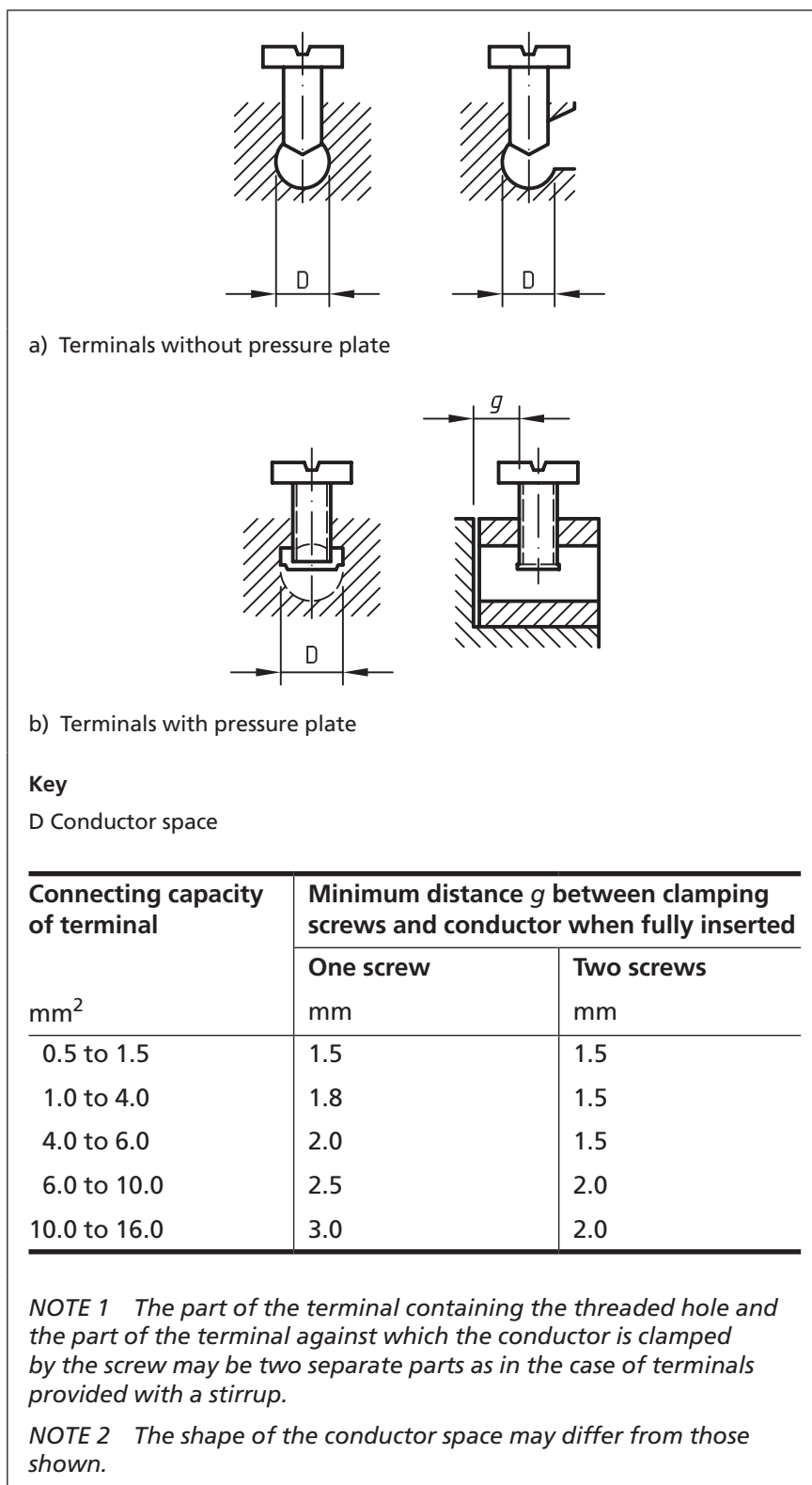

Figure 2 Examples of screw terminals and stud terminals

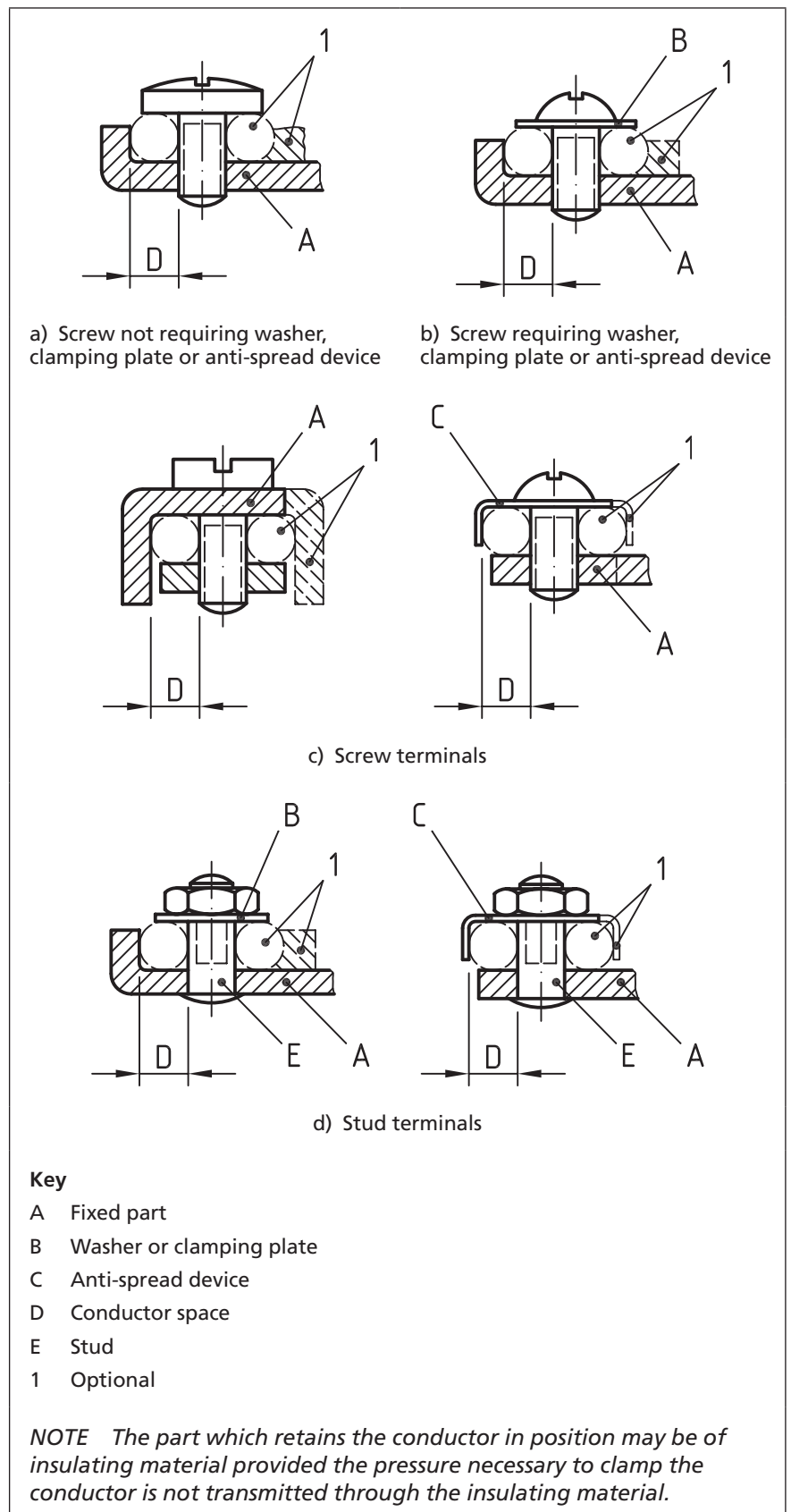

Figure 3 Examples of saddle terminals

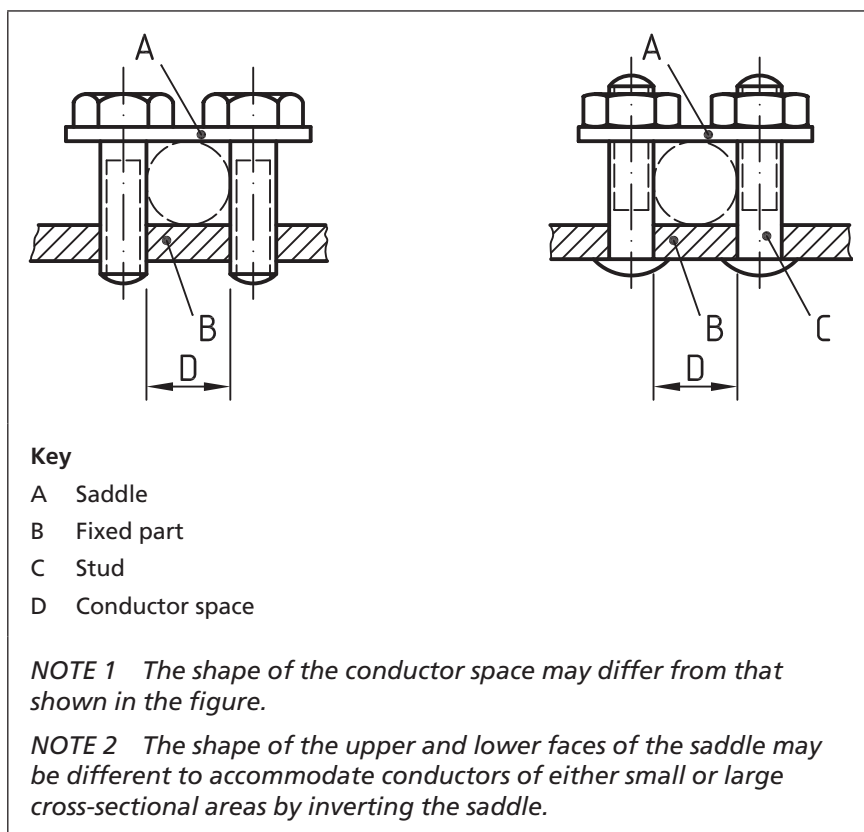

Figure 4 Examples of lug terminals

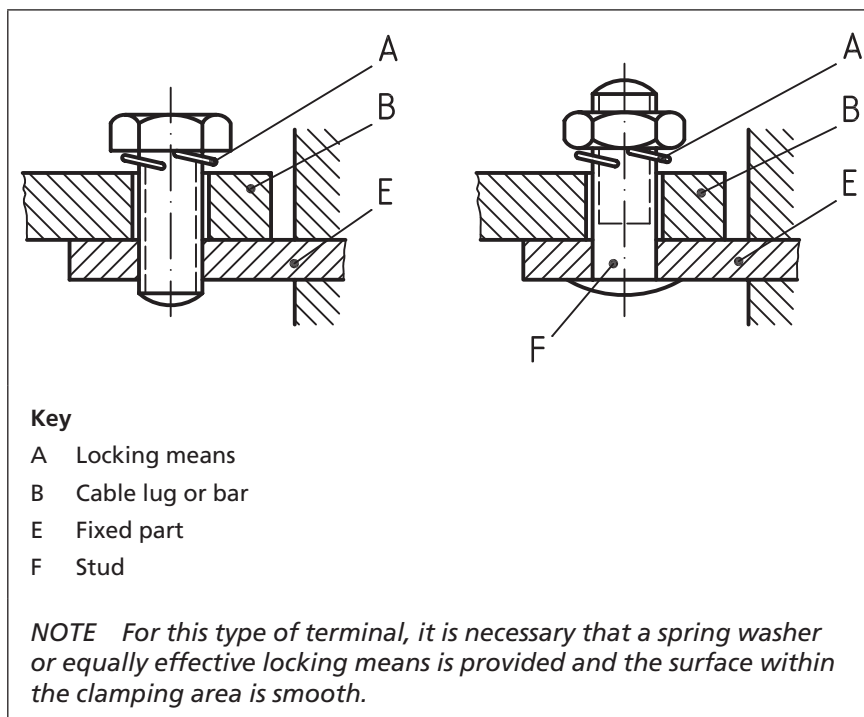

Figure 5 Examples of a mantle terminal

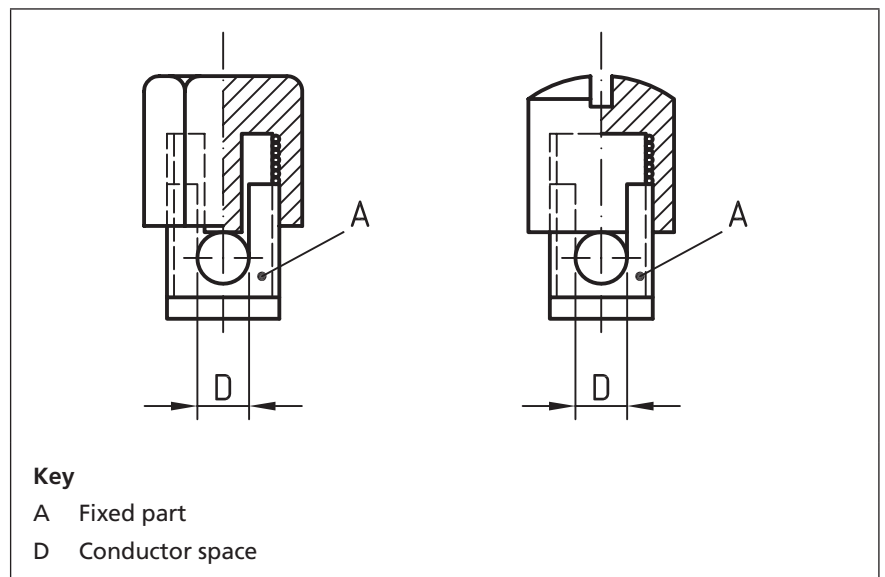

Figure 6 Thread forming tapping screw

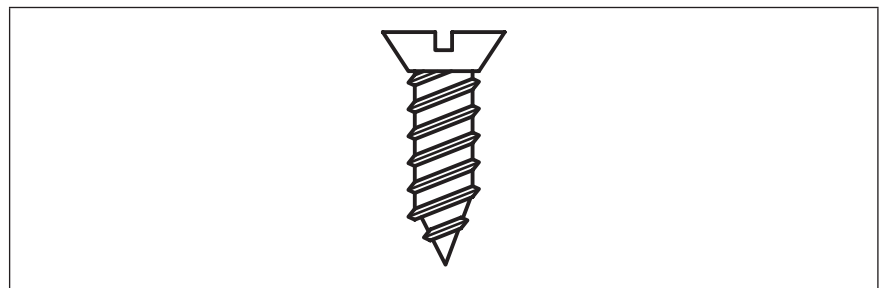
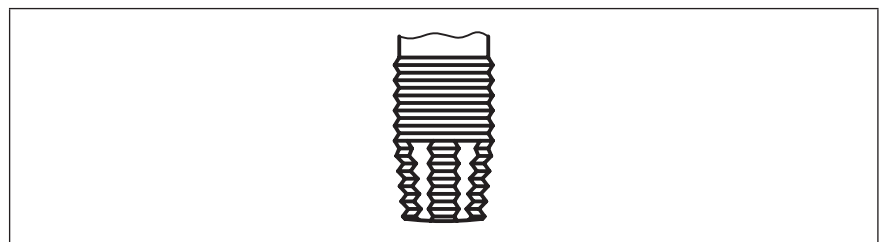

Figure 7 Thread cutting tapping screw



4 Classification

Accessories are classified, as appropriate, as the following:

- a) fixed or portable;
- b) flush or surface or panel-mounting;
- c) rewirable or non-rewirable;
- d) fused or unfused;
- e) switched or unswitched;
- f) with or without provision for earthing;

g) according to the degree of protection against harmful ingress of water:

- 1) ordinary, not higher than IPX0;
- 2) splash-proof, IPX4;
- 3) jet-proof, IPX5;

NOTE The IP ratings are defined in BS EN 60529.

h) for normal use or rough-use;

i) maintenance free.

5 General requirements

5.1 Incorporated components such as plug-pins, socket-contacts, switches, electronic components, printed circuit boards, transformers, timers and control devices shall conform to the relevant British Standard. Where no relevant standard for an incorporated component exists, the requirements of this standard shall apply.

5.2 Accessories shall be so designed and constructed that, in normal use, their performance is reliable and minimizes risk of danger to the user or surroundings.

6 Type testing

6.1 Type test samples shall be submitted to tests in the order specified in **6.3**.

Where components such as plug-pins, socket-contacts, switches, electronic components, printed circuit boards, transformers, timers and control devices, etc., conforming to other British Standards are incorporated, relevant test results obtained during their original conformity procedures may be accepted in order to avoid duplication of testing.

6.2 Unless otherwise specified in this standard the accessories shall be tested as delivered by the manufacturer or responsible vendor and under normal conditions of use, at an ambient temperature of $20\text{ }^{\circ}\text{C} \pm 5\text{ }^{\circ}\text{C}$, after being conditioned at normal laboratory temperature and humidity levels for at least 4 days.

The accessories used for the tests shall be representative of normal production items in respect of all details which may affect the test results.

Non-rewirable accessories shall be supplied with an appropriate cable, flexible cord or extensible lead. Except as specified in **21.3.3** and **21.3.5**, the cord or lead shall be at least 1 m long, including the length of any protective sleeve.

6.3 A total of at least 9 accessories, of any one type, shall be submitted to inspection and tests in the following order:

- a) three accessories: Clauses **5** to **10** (except Annex C) (inspection, measurement, gauging and manipulation);
- b) three accessories: Clauses **11** to **22** (general tests);
- c) up to three accessories: Clause **23** (material test);
- d) two dismantled accessories: Annex C and Clause **25** (material tests).

NOTE 1 The two dismantled accessories may be accessories that have been tested in accordance with item a).

NOTE 2 If any particular test is needed to be repeated, as part of the normal sequence, this is specified in the appropriate test method.

6.4 Accessories shall be deemed to conform if no accessory fails in the complete series of tests given in **6.3**. If one accessory fails in any group in the complete series of tests specified in **6.3**, then accessories of that type shall be deemed to have failed to conform to this standard, unless that accessory is shown to be not representative of normal production or design, in which case a further set of accessories shall be submitted to the test or tests in that group. If there is no failure in this retest then accessories of that type shall be deemed to conform to this standard.

If more than one accessory fails in the complete series of tests given in **6.3** then accessories of that type shall be deemed to have failed to conform to this standard.

7 Rating

Accessories shall have the following:

- a) a rated voltage not exceeding 250 V a.c. and/or 250 V d.c.; and
- b) a rated current not exceeding 63 A.

Conformity shall be checked by inspection of the marking and by the relevant tests given in this standard.

8 Marking

8.1 Information to be marked on accessories

Accessories shall be marked with the information given in items a) and b) in the following list. The other information listed shall be marked if relevant:

- a) the name or trade mark of the manufacturer or responsible vendor;
- b) the number of this British Standard i.e. BS 5733 ¹⁾;
- c) for rough-use plugs and for portable socket-outlets, the number of the standard shall be followed by "/A";
- d) terminal identification, if this is relevant;
- e) the rated current;
- f) the rated voltage;
- g) the nature of supply if this is relevant;
- h) for fused accessories, the word "FUSE" or "FUSED", or the appropriate symbol specified in **8.4**. The fuse marking shall be on the visible exterior of the accessory when in use;

¹⁾ Marking BS 5733 on or in relation to a product represents a manufacturer's declaration of conformity, i.e. a claim by or on behalf of the manufacturer that the product meets the requirements of the standard. The accuracy of the claim is solely the claimant's responsibility. Such a declaration is not to be confused with third-party certification of conformity.

- i) for other than ordinary accessories, an indication of the degree of protection, e.g. IPX4 or IPX5;
- j) in rewirable accessories where cord anchorages are not intended to clamp effectively cords and/or cables smaller than the minimum size appropriate to the accessory, the minimum and maximum sizes for which the cord anchorage is provided, as given in Clause 16, e.g. 6 mm² to 16 mm², shall be marked in an area adjacent to the anchorage;
- k) for accessories incorporating screwless terminals, the length of insulation to be removed, see 14.3.7;
- l) for accessories classified according to Clause 4i) as maintenance free, the appropriate symbol specified in 8.4 (see 14.5);
- A1 m) for accessories incorporating screwless terminals, where the maximum conductor size is not in conformity with Table 2 this shall be marked on the accessory. A1

NOTE The information designated in items j) and k) may be shown on the product and/or the packaging unit.

8.2 Safety information





Where it is necessary, for safe operation, that the user should be aware of any particular characteristics of the accessory, the necessary information shall be given by markings on the accessory itself or, where this is not practicable, in instructions which may accompany it.

8.3 Visibility of marking

The marking specified in 8.1 shall be visible up to the time of installation, but need not be visible thereafter. The marking specified in 8.2, if on the accessory, shall be visible after installation.

8.4 Symbols for marking accessories

If symbols are used they shall be as follows:

Amperes	A
Volts	V
*Alternating current	~
*Direct current	----
Line	L
Neutral	N
*Earth	 preferred or 
*On	I
*Off	O
*Fuse	
Cord/cable size	mm ² or mm
Maintenance free	

NOTE IEC 60417-DB gives guidance on symbols marked *. However, strictly proportional reductions may not be practical in certain media

and interpretative licence is permissible, provided that a clear graphical representation of symbol is produced which communicates the intention.

8.5 Marking of rated current and voltage

The marking of rated current, voltage and nature of supply shall be marked in one of the following ways:

- a) for marking of rated current and rated voltage for a.c. accessories:

10A 250V ~ or 10/250 ~ or $\frac{10}{250}$ ~
 or 10A 250V a.c. or 10/250 a.c.

- b) for marking of rated current and rated voltage for d.c. accessories:

10A 250V ===== or 10/250 ===== or $\frac{10}{250}$ =====
 or 10A 250V d.c. or 10/250 d.c.

- c) for marking of rated current and rated voltage for accessories which have a dual voltage rating:

10A 125-230V ~ or $\frac{10}{125-230}$ ~

- d) for marking of rated current and rated voltage for accessories with an a.c. and a d.c. current rating:

10A ===== 16A ~ 250V or 10 ===== 16 ~/250 or $\frac{10 ===== 16 \sim}{250}$
 or 10A d.c. 16A a.c. 250V or 10 d.c. 16 a.c./250 or $\frac{10 \text{ d.c. } 16 \text{ a.c.}}{250}$

- e) for marking of ratings for accessories with an a.c. and a d.c. current rating where the rated voltages are different, separate markings as shown in a), b) or c) above shall be used.

8.6 Inspection

Conformity to the requirements of 8.1 to 8.5 shall be checked by inspection.

8.7 Durability and legibility of markings

8.7.1 General

Marking on the accessory shall be legible and durable and shall not be placed on screws, washers or other easily removable parts.

8.7.2 Test for legibility

Conformity shall be checked by inspection, using normal or corrected vision without additional magnification.

8.7.3 Test for durability

Marking made by engraving, moulding, or a similar permanent process, is deemed to conform to the requirement for durability, without the need for testing.

Unless the marking is made by engraving, moulding or a similar permanent process, the marking shall be rubbed by hand, for

approximately 15 s using a piece of cloth soaked in water and again for approximately 15 s with a piece of cloth soaked in aliphatic solvent hexane with a content of aromatics of maximum 0.1% by volume, a kauri-butanol value of 29, initial boiling point of approximately 65 °C, a dry point of approximately 69 °C, and a relative density of approximately 0.68. When tested by this method, the marking shall remain legible.

9 Dimensions

Where products have dimensional requirements which are important for interchangeability with products conforming to other standards, the relevant dimensions shall be within the tolerances specified in the relevant standard.

For products or components which are intended to be interchangeable with products or components conforming to other standards, conformity shall be checked by inspection, measurement or gauges as specified in the relevant standards.

For products or components which are intended to be interchangeable with products or components for which there are no applicable standards, the products or components shall have dimensions and tolerances in accordance with those specified by the manufacturer or responsible vendor. Conformity shall be checked by inspection, measurement or gauges.

10 Clearances, creepage distances and solid insulation

10.1 General

Accessories energized directly from the low-voltage supply shall be Overvoltage Category III in accordance with Annex D.

Accessories shall be constructed so that the clearances, creepage distances and solid insulation are adequate to withstand the electrical stresses taking into account the environmental influences that may occur. Clearances, creepage distances and solid insulation shall conform to the relevant requirements of **10.2**, **10.3** and **10.4**.

The distance between lead wires in the pinch of a neon lamp with external resistor shall be a minimum of 1 mm.

Accessories shall conform to the requirements for basic insulation in **10.2.2** and **10.3.2** and for functional insulation in **10.2.3** and **10.3.3**.

If the manufacturer declares an insulation level exceeding basic insulation then the accessory shall be tested accordingly.

NOTE 1 The requirements and tests are based on BS EN 60664-1.

NOTE 2 Product insulation consists of basic insulation and protective earthing as required by BS EN 61140 for Class I equipment. Mechanical strength equivalent to that which would be provided by reinforced insulation as listed in BS EN 61140 is specified for BS 5733 products through the specific mechanical and material requirements of BS 5733.

10.2 Clearances

10.2.1 General

The clearances shall be dimensioned to withstand the rated impulse voltage declared by the manufacturer taking into account the rated voltage and the overvoltage category as given in Annex D and the pollution degree declared by the manufacturer in accordance with Annex E.

For the measurements, all parts which can be removed without the use of a tool shall be removed and moveable parts which can be assembled in different orientations shall be placed in the most unfavourable position.

NOTE Moveable parts are, for example, hexagonal nuts, the position of which cannot be controlled throughout an assembly.

10.2.2 Clearances for basic insulation

The clearances for basic insulation shall be not less than the values given in Table 1A except as described below.

It shall be permissible to use smaller unspecified clearances [except those values marked in Table 1A with a reference to Footnote ^{B)}] if the accessory passes the impulse withstand voltage test of Annex F at the impulse voltage specified in Annex D, but only if the parts are rigid or located by mouldings or if the construction is such that it is unlikely that distances will be reduced by distortion or by movement of the parts during mounting, connection and normal use.

Conformity shall be checked by inspection, and if necessary by measurement, or by the test of Annex F.

If clearance distances are to be measured, this shall be carried out in accordance with Annex B.

Table 1A Minimum clearances for basic insulation

Rated impulse withstand voltage kV ^{A)}	Minimum clearances in air up to 2 000 m above sea level mm
0.33	0.2 ^{B)}
0.50	0.2 ^{B)}
0.80	0.2 ^{B)}
1.5	0.5
2.5	1.5
4.0	3
6.0	5.5

^{A)} See Annex D. This voltage is:

- for functional insulation: the maximum impulse voltage expected to occur across the clearance;
- for basic insulation directly exposed to or significantly influenced by transient overvoltage from the low-voltage mains: the rated impulse withstand voltage of the accessory;
- for other basic insulation: the highest impulse voltage that can occur in the circuit.

^{B)} Minimum clearance values are based on BS EN 60664-1.

10.2.3 Clearances for functional insulation

The clearances for functional insulation shall be not less than the values specified for basic insulation in **10.2.2**.

Conformity shall be checked by inspection, and if necessary by measurement, or by the test of Annex F. If clearance distances are to be measured, this shall be carried out in accordance with Annex B.

10.2.4 Clearances for supplementary insulation

The clearances for supplementary insulation shall be not less than the values specified for basic insulation in **10.2.2**.

Conformity shall be checked by inspection, and if necessary by measurement, or by the test of Annex F. If clearance distances are to be measured, this shall be carried out in accordance with Annex B.

10.2.5 Clearances for reinforced insulation

The clearances for reinforced insulation shall be not less than the values specified for basic insulation in **10.2.2** but using the next higher step for rated impulse withstand voltage given in Table 1A.

Conformity shall be checked by inspection and by measurement, or by the test of Annex F.

10.2.6 Contact gap

The minimum clearance between current-carrying parts separated by the action of the switch shall be 1.2 mm in the open position.

Conformity shall be checked by measurement.

10.3 Creepage distances**10.3.1 General**

The creepage distances shall be dimensioned for the voltage which is expected to occur in normal use taking into account the pollution degree (see Annex E), and the material group, as declared by the manufacturer.

For the measurements, all parts which can be removed without the use of a tool shall be removed and moveable parts which can be assembled in different orientations shall be placed in the most unfavourable position.

NOTE 1 Moveable parts are, for example, hexagonal nuts, the position of which cannot be controlled throughout an assembly.

NOTE 2 A creepage distance cannot be less than the associated clearance.

Creepage distances shall be measured in accordance with Annex B.

The relationship between material group and the comparative tracking index (CTI) values and proof tracking index (PTI) values shall be as follows:

- Material group I $600 \leq \text{CTI/PTI}$;
- Material group II $400 \leq \text{CTI/PTI} < 600$;
- Material group IIIa $175 \leq \text{CTI/PTI} < 400$;
- Material group IIIb $100 \leq \text{CTI/PTI} < 175$.

The CTI or PTI values shall be determined in accordance with Annex C.

NOTE 3 For glass, ceramics and other inorganic materials which do not track, creepage distances need not be greater than their associated clearances.

10.3.2 Creepage distances for basic insulation

The creepage distances for basic insulation shall be not less than the values given in Table 1B. Conformity shall be checked by measurement.

Table 1B Minimum creepage distances for basic insulation

Rated voltage ^{A)} V (r.m.s.)	Minimum creepage distance mm					
	Pollution degree 2 ^{B)}			Pollution degree 3 ^{B)}		
	Material group I	Material group II	Material group IIIa/IIIb	Material group I	Material group II	Material group IIIa
≤250	1.3	1.8	2.5	3.2	3.6	4.0

^{A)} This voltage is the voltage rationalized in accordance with BS EN 60664-1:2007, Table F.3a and Table F.3b.

^{B)} Details of pollution degrees are given in Annex E.

10.3.3 Creepage distances for functional insulation

The creepage distances for functional insulation shall be not less than the values specified for basic insulation in 10.3.2.

Conformity shall be checked by measurement.

10.3.4 Creepage distances for supplementary insulation

The creepage distances for supplementary insulation shall be not less than the values specified for basic insulation in 10.3.2.

Conformity shall be checked by measurement.

10.3.5 Creepage distances for reinforced insulation

The creepage distances for reinforced insulation shall be not less than twice the distances specified for basic insulation in Table 1B.

Conformity shall be checked by measurement.

10.4 Solid insulation

10.4.1 General

Solid insulation for basic, supplementary, reinforced and functional insulation shall be capable of withstanding electrical stresses which might occur in normal use.

NOTE No minimum thickness is specified for solid insulation.

10.4.2 Basic, supplementary and functional solid insulation

Basic, supplementary and functional solid insulation shall each withstand the required impulse voltage declared by the manufacturer of the accessory, as specified in 10.2.2 for Overvoltage Category III.

Conformity shall be checked by tests in accordance with Annex F, followed by tests in accordance with 19.3 using the values given in Table 1C.

10.4.3 Reinforced solid insulation

Reinforced solid insulation shall be dimensioned to withstand the required impulse voltage, but one step higher than that specified for basic insulation in 10.4.2.

Conformity shall be checked by tests in accordance with Annex F, followed by tests in accordance with 19.3 using the values given in Table 1C.

Table 1C Withstand test voltages for solid insulation types

Insulation type	Test voltage V (r.m.s.)
Functional solid insulation	1 500
Basic solid insulation	1 500
Supplementary solid insulation	1 500
Reinforced solid insulation	3 000

11 Accessibility of live parts

11.1 Accessories shall be so constructed and enclosed that there is protection against accidental contact with live parts when the accessories are correctly assembled or mounted and connected for their intended purpose. Live parts shall not be accessible without the use of a tool even after the removal of parts which can be removed without the use of a tool.

When tested using test probe 11 of BS EN 61032:1998 applied with a force of 5_{-1}^0 N in every position which would be possible with the accessories correctly assembled or mounted and connected for their intended purpose and with conductors of the smallest cross-sectional area appropriate to the accessories, there shall be no contact between the test probe and any live part. The test shall be repeated with the accessories fitted with conductors of the largest cross-sectional area appropriate to the accessories.

For accessories incorporating plug-pins and/or socket-contacts not conforming to another British Standard, test probe 11 of BS EN 61032:1998 shall be applied in every possible position when the accessories are in partial or complete engagement with corresponding accessories.

An electrical indicator with a voltage of $45 \text{ V} \pm 5 \text{ V}$ shall be used to show contact with the relevant part.

11.2 Accessories which incorporate shutters to provide increased protection against electric shock shall be so constructed that live parts protected by the shutters are not accessible with the test pin shown in Figure 8 even after the removal of parts which can be removed without the use of a tool.

Figure 8 Gauge for checking non-accessibility through shutters

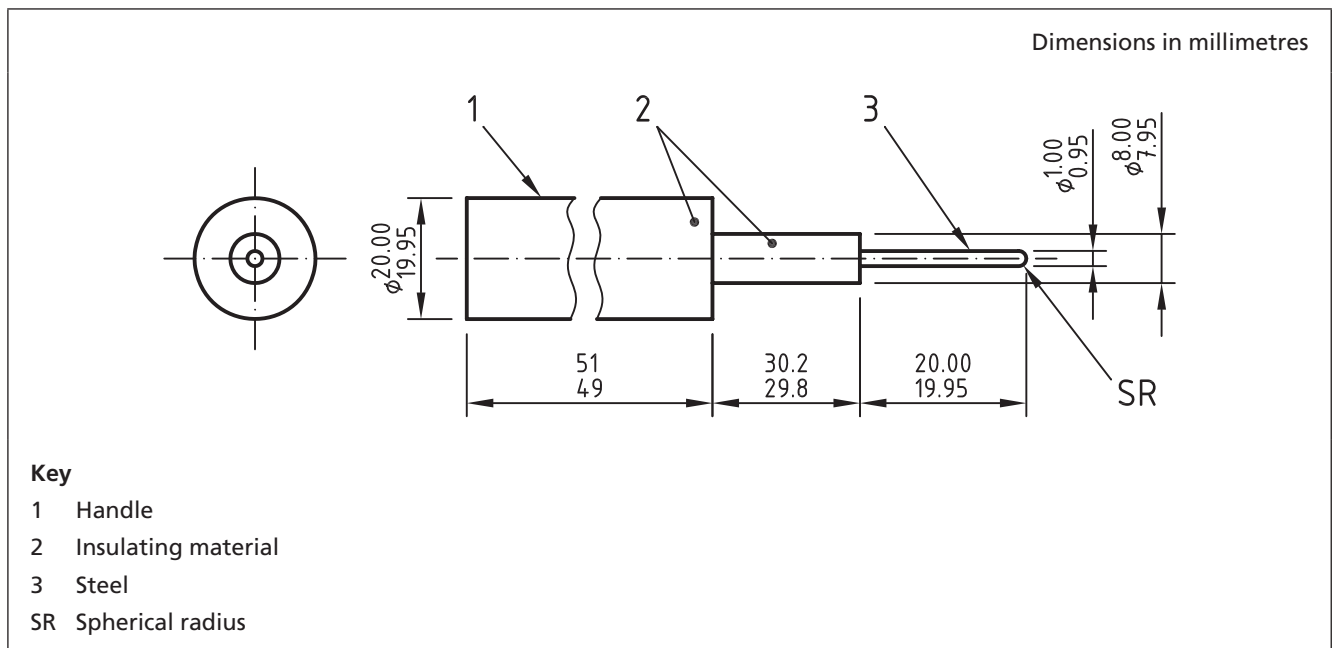

To facilitate this degree of protection, the accessories shall be so constructed that live parts are automatically screened by a shutter, or shutters, which are not operated solely by the insertion of one current-carrying plug-in contact.

When tested by applying the test pin to each shutter with a force of 5_{-1}^0 N, applied perpendicular to the engagement face of the accessory, it shall not be possible to touch live parts.

11.3 Accessories incorporating plug-in and/or socket devices shall be so constructed as to prevent:

- a) any associated earthing plug-pin from making contact with a current-carrying socket-contact; and/or
- b) any associated current-carrying plug-pin from making contact with a current-carrying socket-contact while any other plug-pin is accessible.

NOTE The term *plug-pin* is, in this context, taken to include any means by which the plug-in device makes electrical contact with the socket device.

Conformity shall be checked by inspection and application of a corresponding accessory.

11.4 For accessories incorporating plug-in and/or socket devices, any earthing plug-pin shall make and break contact with the earthing socket-contact respectively before and after the current-carrying plug-pins make and break contact with the current-carrying socket-contacts.

NOTE The term *plug-pin* is, in this context, taken to include any means by which the plug-in device makes electrical contact with the socket device.

Conformity shall be checked by inspection and application of a corresponding accessory.

11.5 Where an accessory intended to be inserted into an accessory incorporating socket-contacts is supplied fitted with a flexible cord, the free end of the flexible cord shall be encapsulated in insulating material.

NOTE This does not apply to assemblies supplied to equipment manufacturers for incorporation into their products.

Conformity shall be checked by inspection.

11.6 In portable plug-in fused accessories it shall be impossible to gain access to the fuse-link whilst the portable accessory is in engagement with an associated accessory.

Conformity shall be checked by inspection.

11.7 In fused accessories, other than those mentioned in **11.6**, where the fuse-link is intended to be replaced by the user with or without the use of a tool, it shall be possible to remove and replace the fuse-link safely.

Where necessary, instructions shall be provided as specified in **8.2**.

When tested using test probe 11 of BS EN 61032:1998, applied with a force of 30_{-5}^0 N, it shall not be possible to touch live parts with the test probe during removal or replacement of the fuse-link.

11.8 The base and cover of non-rewirable portable accessories shall be permanently attached to each other. Conformity shall be checked by inspection.

11.9 The base and cover of rewirable portable accessories shall be firmly secured to each other so that they cannot be separated without the use of a tool.

Conformity shall be checked by inspection. Where one or more cover fixing screws are subjected to a tensile force during normal insertion and withdrawal the following test shall be performed.

A pull of 60_{-2}^0 N shall be exerted upon each cover fixing screw for 60_{0}^{+5} s whilst at a temperature of $70\text{ °C} \pm 2\text{ °C}$. The test shall be performed using apparatus similar to that shown in Figure 9 and for the test the accessory cover and apparatus shall be placed in an oven until they reach the required temperature.

At the end of the test any screw thread shall be capable of performing its intended function and no insert shall have moved to such an extent that correct assembly of the accessories is prevented.

Figure 9 Apparatus for testing accessory enclosure fixing screws

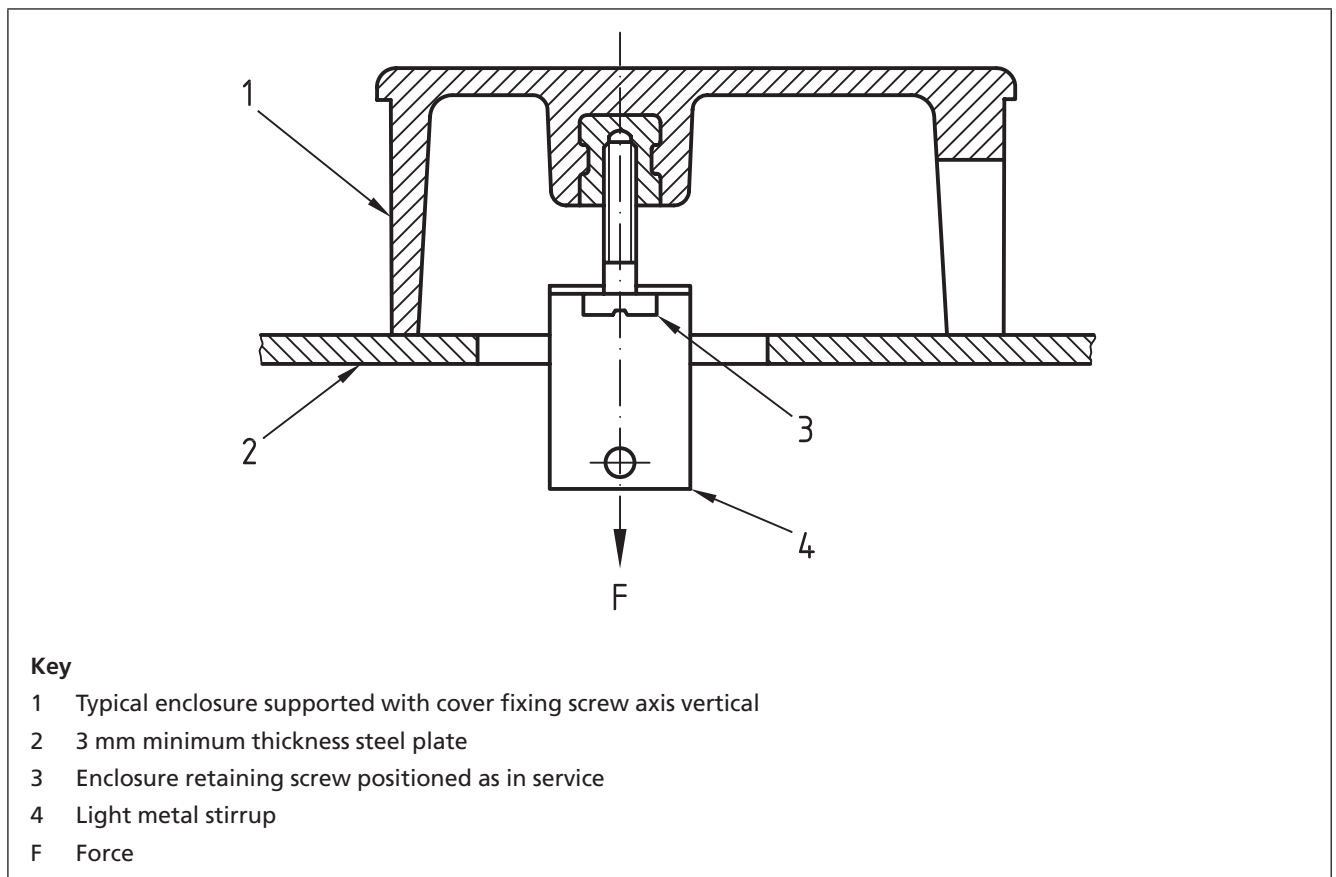

12 Provision for earthing

12.1 With the exception of accessories conforming to 12.2, provision shall be made for the effective earthing of all metal parts that may become live in the event of failure of the insulation of the accessory or conductors, and which are capable of being touched during normal operation of the accessory.

NOTE This requirement does not apply to metal parts on, or screws in or through, non-conducting material and separated by such material from live parts in such a way that, in normal use, they cannot become live.

The connection between the earthing terminal or earthing contact and parts required to be connected thereto shall be of low resistance.

Conformity shall be checked by inspection and by the following tests, as applicable.

A current of $25 \text{ A} \pm 0.75 \text{ A}$ derived from an a.c. source having a no-load voltage not exceeding 12 V , shall be passed for 60^{+5}_0 s as follows:

- a) for all accessories, between the earthing terminal and any accessible metal parts intended to be earthed;
- b) for plugs, between the earthing terminal and both the remote end of the earthing plug-pin and any accessible metal parts intended to be earthed;

- c) for socket-outlets, between the earthing terminal and any accessible metal parts intended to be earthed and between the earthing terminal and a plug-pin inserted into the earthing socket-contact;
- d) for plug/socket type adaptors without earthing terminals, between corresponding earthing plug-pin inserted fully into the earthing socket-contact and the remote end of the earthing plug-pin of the adaptor;
- e) for accessories required to provide earthing continuity for class 1 equipment, between the incoming and outgoing earthing terminals, if these are separate;
- f) where an accessory is supplied complete with one of the following:
 - 1) an insulated, sheathed flexible cord, containing an earth continuity conductor;
 - 2) a metallic sheathed flexible cord with or without an incorporated earth continuity conductor; or
 - 3) a flexible metallic conduit containing a flexible insulated cord, or insulated flexible conductors;

then the resistance of the total length of the earth continuity conducting path, whether this is internal or external, is deducted from the resistance measured between the earthing terminal, termination, pin or contact of the accessory, and the remote end of the earth continuity conductor.

The resistance between the earthing terminal and any other nominated part shall not exceed 0.05Ω .

12.2 The requirements of **12.1** shall not apply to accessories having accessible metal parts, such as removable covers or cover plates, where such accessories are not intended to provide earthing continuity for class 1 equipment provided that:

- a) such accessible metal parts are separated from live parts, by parts of insulating material fixed to the accessible metal parts or to the body of the accessory; and
- b) such parts of insulating material cannot be removed without being permanently damaged or are so designed that they cannot be removed and replaced in an incorrect position; and
- c) if they are omitted, the accessory is rendered inoperable or manifestly incomplete; and
- d) there is no risk of accidental contact between live parts and metal covers or cover plates, for example through their fixing screws, even if a conductor should come away from its terminal; and
- e) precautions are taken in order to prevent creepage distances or clearances becoming less than the values specified in Clause **10**.

Conformity shall be checked by inspection and test, using the method described in Clause **19** but with an electric strength test voltage of (4000 ± 120) V.

13 Construction

13.1 Current-carrying parts and parts of the earthing contacts shall be made of brass, copper, phosphor-bronze or other material of at least equal conductivity, resistance to abrasion and resistance to corrosion.

Conformity shall be checked by inspection and by the tests of **13.12**, and Clauses **20** and **25**.

This requirement shall not be applied to screws, nuts, washers, clamping plates and similar parts of terminals, nor to parts of the accessory used for earth continuity purposes.

13.2 Sealing compounds shall be of insulating material capable of maintaining a satisfactory seal under service conditions. Bituminous filling compounds shall conform to the requirements of BS 1858:2002. Other sealing compounds shall conform to any relevant British Standards.

When tested in accordance with **22.2**, the accessories shall be resistant to heat in accordance with **22.1**.

13.3 Boxes shall be so constructed that they cannot readily be deformed, cannot be brought into contact with any live parts and do not allow access to any live parts when the installation has been completed by the fixing in position of the accessories.

Conformity shall be checked by inspection and by the relevant test of Clause **21** followed by repeating the tests given in Clause **11**.

13.4 Boxes, not within the scope of other British Standards, shall conform to the relevant clauses of this standard.

Non-metallic boxes shall have provision for securing an earthing terminal which shall allow the proper connection of conductors having the cross-sectional areas shown in Table 2. Such terminals intended for the looping-in of two or more conductors shall be checked by being fitted with the permissible number of conductors.

13.5 Where the maintenance of polarity is necessary for the functioning of the accessory, or the equipment or installation with which it is intended to be used, the internal connections shall be designed so that any plug-pins and socket-contacts and any terminals or terminations for conductors maintain correct polarity between input and output sides of the accessories.

Conformity shall be checked by inspection and by an electrical continuity test.

13.6 Terminals of portable rewirable accessories shall be so located or shielded that, should a wire of a stranded conductor escape when the conductors are fitted, there is no risk of accidental connection between live parts and accessible external surfaces, or of a stray wire bypassing any fuse-link.

When tested in accordance with the following test, the free wire of the conductor connected to a live terminal shall not touch any live part that is accessible or is connected to an accessible metal part. Furthermore, the free wire of the conductor connected to a live terminal shall not reduce creepage distances and clearances to accessible surfaces to less than 1.3 mm. The free wire of a conductor connected to an earthing terminal shall not touch any live part.

A length of insulation, of approximately 4 mm, shall be removed from the end of a flexible conductor. The cross-sectional area shall be the maximum size as given in Table 2. One wire of the stranded conductor shall be left free and the other wires fully inserted into, and clamped in, the terminal.

The free wire shall be bent, without tearing the insulation back, in every possible direction but without making sharp bends around barriers.

13.7 Fuse contacts shall be made from materials conforming to **13.1**.

NOTE They may be supplemented by additional mechanical means to maintain contact pressure on a corresponding cartridge fuse-link, or they may be inherently resilient by virtue of the contact material chosen.

Fuse contacts shall conform to **15.3**.

Conformity shall be checked by inspection, and for inherently resilient contacts, by the following test.

A solid link shall be manufactured from stainless steel, as follows:

- a) for accessories using fuse-links conforming to BS 646, the dimensions shall be as shown in Figure 10, type a;
- b) for accessories using fuse-links conforming to BS 1362, the dimensions shall be as shown in Figure 10, type c;
- c) for accessories using fuse-links conforming to other standards, the dimensions shall be the maximum shown on the relevant standards sheet, but with the following permissible negative tolerances:
 - 1) fuse cap diameters: -0.01 mm;
 - 2) lengths: -0.04 mm.

The appropriate solid link shall be inserted and withdrawn from the fuseclips of the fused accessory 10 times in succession (20 movements) in a normal manner, at a rate of approximately 10 insertions per minute. The stainless steel solid test link shall be removed at the end of the tests.

After the test the stainless steel solid test link shall, for the remaining tests of this standard, be replaced by a solid link of negligible impedance, having the dimensions specified in Figure 10, type b or type d or, for other fuses, having minimum dimensions according to their relevant standard sheets with the following permissible positive tolerances:

- i) fuse cap diameters $+0.01$ mm;
- ii) lengths $+0.04$ mm.

13.8 Accessories incorporating switches shall be so constructed that when the switch is operated in a normal manner, the switch contacts come to rest only in a state giving adequate contact or adequate separation of the contacts as indicated by the position of the actuating member.

Conformity shall be checked by inspection and by an operational test.

13.9 Multi-pole switches shall be so designed and constructed that all contacts make or break with one movement of the actuating member.

Conformity shall be checked by inspection.

13.10 Switches, other than those for a.c. only, shall be of the quick make and break (snap action) type and the speed of contact making and breaking shall be independent of the speed at which the actuating member is operated.

Conformity shall be checked by inspection and by manual test.

Figure 10 Solid link for test on fuseclips

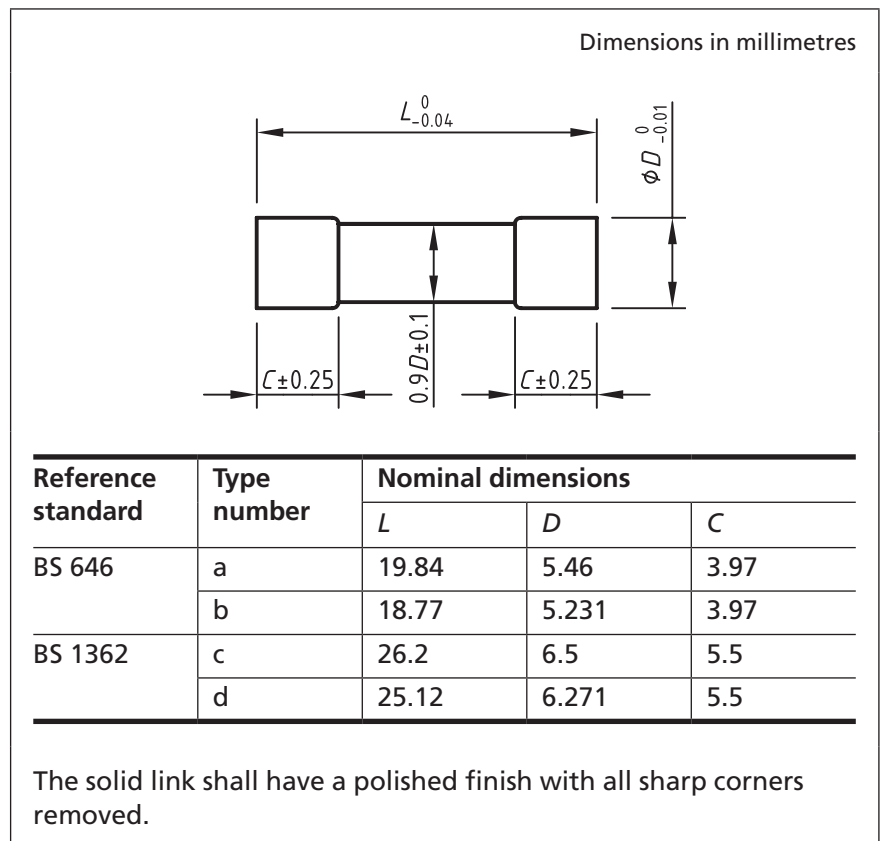

13.11 For accessories incorporating switches which do not conform to other British Standards, the switch portion shall be tested in accordance with the following clauses of BS EN 60669-1:1999+A2:

- Clause **18** – Making and breaking capacity, where appropriate to the declared function of the switch;
- Clause **19** – Normal operation.

Conformity shall be checked by carrying out the nominated tests of BS EN 60669-1:1999+A2.

13.12 Socket-contacts incorporated in accessories which do not conform to other British Standards shall withstand, without excessive wear or other harmful effects, the electrical and mechanical stresses occurring in use.

When tested in accordance with the following test, the plug and socket device shall not show any wear impairing its operation and the inlet openings in the cover of the socket portion shall not show any appreciable damage. Shutters, if fitted, shall still be operating satisfactorily and the socket-contacts safely shielded.

A combination of appropriate plugs and the accessory incorporating socket-contacts under test shall be operated by mechanically withdrawing and inserting the plug portion:

- 15 000 times (30 000 movements) for normal accessories, the plug-pins being renewed after each 5 000 insertions and withdrawals;
- 300 times (600 movements) for “infrequent use” accessories excluding fuse-holders.

The plug-pins and socket-contacts, when engaged, shall carry the rated current $\pm 2\%$ at the rated voltage $\pm 5\%$ in a substantially non-inductive circuit.

Each plug shall be inserted into and withdrawn from the accessory under test at a rate of approximately six insertions and six withdrawals per minute, the speed of travel of the plug being approximately 150 mm/s. The periods during which the plug is inserted and withdrawn shall be approximately equal.

For the purpose of this test no lubrication shall be applied to the plug or socket-contacts under test.

The plug and socket device shall still conform to Clauses **19** and **20** when tested with the last of the plugs used for the insertion and withdrawal test for normal accessories and the plug and socket device used for the test for infrequent use, as applicable.

13.13 Where an accessory incorporates a fuse-link which may be withdrawn or replaced on load, the accessory shall be tested as follows and the accessory shall be capable of correctly performing its intended function.

The fuse contacts shall make and break the rated current $\pm 2\%$, by insertion and removal of a solid link, in accordance with **13.7**, in a substantially non-inductive circuit at rated voltage $\pm 5\%$, 10 times in succession at intervals of approximately 30 s.

For the test, all metal parts not in contact with line contacts shall be connected to the earth pole of the test circuit.

After the test the accessory shall be in a serviceable condition.

13.14 The female contacts and the contacts of a male connector of a lighting distribution unit shall withstand, without excessive wear or other harmful effects, the electrical and mechanical stresses occurring in use.

When tested in accordance with the following test, they shall not show any wear impairing their operation. A combination of appropriate male connector and female contacts under test shall be operated by mechanically withdrawing and inserting the male connector.

The male connector shall be inserted and withdrawn at a rate of approximately six insertions and six withdrawals per minute, the speed of travel of the male connector being approximately 150 mm/s. The periods during which the male connector is inserted and withdrawn shall be approximately equal.

The following tests shall be conducted:

- a) an inductive load equal to the rated current of the outlet, at 0.6 power factor (lagging) shall be connected to the male connector. One hundred operations (200 movements) shall be carried out; and
- b) a load comprising five 100 W 250 V tungsten filament lamps for general service conforming to BS EN 60064, at approximately unity power factor, shall be connected to the male connector. One hundred operations (200 movements) shall be carried out.

For the purpose of this test no lubrication shall be applied to the contacts under test.

The female contacts and the contacts of a male connector shall still conform to Clauses 19 and 20 when tested with the last male connector used for the insertion and withdrawal test.

13.15 Accessories classified according to Clause 4i) as maintenance free (see 3.31) shall incorporate screwless terminals conforming to 14.3 and 14.5 and cable clamps conforming to Clause 16.

Maintenance free accessories incorporating plug pins and socket contacts, shall be provided with retaining means. The retaining means shall engage automatically when plug pins and socket contacts are correctly connected and shall be capable of disengagement for disconnecting. It shall only be possible to render the means of retention ineffective by a deliberate or intentional act.

Maintenance free accessories shall not be provided with other devices or components such as switches, fuses, relays, thermostats, surge protective device and thermal current-limiting devices.

Conformity shall be checked by inspection and by the relevant tests given in 14.3, 14.5 and Clause 16.

13.16 Accessories incorporating plug pins shall not impose undue strains on fixed socket outlets. Accessories intended for engagement with socket outlets conforming to BS 1363-2 shall conform to BS 1363-3:1995+A3, 13.10.

14 Terminals and terminations

14.1 Terminals for rewirable accessories

Rewirable accessories shall be provided with terminals having screw clamping or with screwless terminals.

NOTE The number of conductors to be clamped is dependent upon the application of the accessory.

The means for clamping the conductors in the terminals shall not serve to fix any other component, although they may hold the terminals in place or prevent them from turning.

Conformity shall be checked by inspection and by the tests of 14.2 or 14.3, as applicable.

In addition, screwless terminals for use within accessories classified according to Clause 4i) as maintenance free shall be checked by inspection and by the tests of 14.5.

14.2 Terminals with screw clamping for copper conductors

14.2.1 Terminals shall be designed such that it is possible to properly connect copper conductors having nominal cross-sectional areas as shown in Table 2.

Conformity shall be checked by inspection, by measurement and by fitting conductors of the smallest and then the largest nominal cross-sectional areas specified.

14.2.2 Terminals with screw clamping shall be designed such that the conductor can be connected without special preparation except as permitted in **14.2.12**.

NOTE The term "special preparation" covers soldering of the wires of the conductor, use of cable lugs, formation of eyelets, etc., but not the reshaping of the conductor before its introduction into the terminal or the twisting of a flexible conductor to consolidate the end.

Conformity shall be checked by inspection.

14.2.3 Terminals with screws or nuts for clamping conductors shall have an ISO metric thread or a thread comparable in pitch and mechanical strength.

Screws shall not be of metal which is soft or liable to creep, such as zinc or aluminium.

NOTE SI, BA and UN threads are considered to be comparable in pitch and mechanical strength to ISO metric thread.

Conformity shall be checked by inspection and by the tests of **14.2.6** and **14.2.8**.

14.2.4 When tested in accordance with **15.5**, terminals with screw clamping shall be resistant to corrosion.

14.2.5 Terminals with screw clamping shall be so designed that they clamp the conductor(s) without undue damage to the conductor(s).

Conformity shall be checked by inspection. When terminals intended for the connection of rigid (solid or stranded) conductors are tested in accordance with the following method, the solid conductor or any strand of a stranded conductor shall not come out of, or break at, the terminal.

The terminal shall be fitted with a rigid (solid or stranded) conductor(s), according to Table 2, first with the smallest and then with the largest cross-sectional area, the clamping screws or nuts being tightened with the torque as given in Table 3.

Each conductor in turn shall be subjected separately to two circular motions as shown in Figure 11 using the appropriate value of H .

Table 2 Conductors to be accommodated by terminals

Ranges of rated currents	Rigid conductors (solid or stranded) nominal cross-sectional area ^{A)} (inclusive) mm ²	Flexible conductors (cords or cables) nominal cross-sectional area ^{A)} (inclusive) mm ²
A		
Up to 6	1 to 1.5	0.5 to 0.75
Above 6 up to and including 10	1 to 1.5	0.5 to 1.0
Above 10 up to and including 16	1 to 2.5	0.5 to 1.5
Above 16 up to and including 25	1.5 to 4.0	1.5 to 2.5
Above 25 up to and including 32	4.0 to 6.0	2.5 to 4.0
Above 32 up to and including 45	6.0 to 10.0	4.0 to 6.0
Above 45 up to and including 63	10.0 to 16.0	6.0 to 10.0

^{A)} For screwless terminals, where the maximum conductor size is marked on the accessory in relation to the rated current, the marked maximum conductor size applies. This shall be not greater than the values given in the table. A1

Table 3 Torque values for test of screws and nuts

Nominal outside diameter of thread mm	Torque N·m				
	1 ^{A)}	2 ^{B)}	3 ^{C)}	4 ^{D)}	5 ^{E)}
Up to and including 2.8	0.2	—	0.4	—	0.4
Over 2.8 up to and including 3.0	0.25	—	0.4	—	0.4
Over 3.0 up to and including 3.2	0.3	—	0.6	—	0.6
Over 3.2 up to and including 3.6	0.4	—	0.8	—	0.8
Over 3.6 up to and including 4.1	0.7	1.2	1.2	1.2	1.2
Over 4.1 up to and including 4.7	0.8	1.2	1.8	1.8	1.8
Over 4.7 up to and including 5.3	0.8	1.4	2.0	2.0	2.0
Over 5.3 up to and including 6.0	—	1.8	2.5	3.0	3.0

- A) Applicable to screws without heads if the screw when tightened does not protrude from the hole, and to other screws which cannot be tightened by means of a screwdriver with a blade wider than the diameter of the screw.
- B) Applicable to nuts of mantle terminals which are tightened by means of a screwdriver.
- C) Applicable to other screws or threaded fixing devices which are tightened by means of a screwdriver.
- D) Applicable to nuts of mantle terminals in which the nut is tightened by means other than a screwdriver.
- E) Applicable to screws or nuts, other than nuts of mantle terminals, which are tightened by means other than a screwdriver.

Figure 11 Arrangement for checking damage to conductors

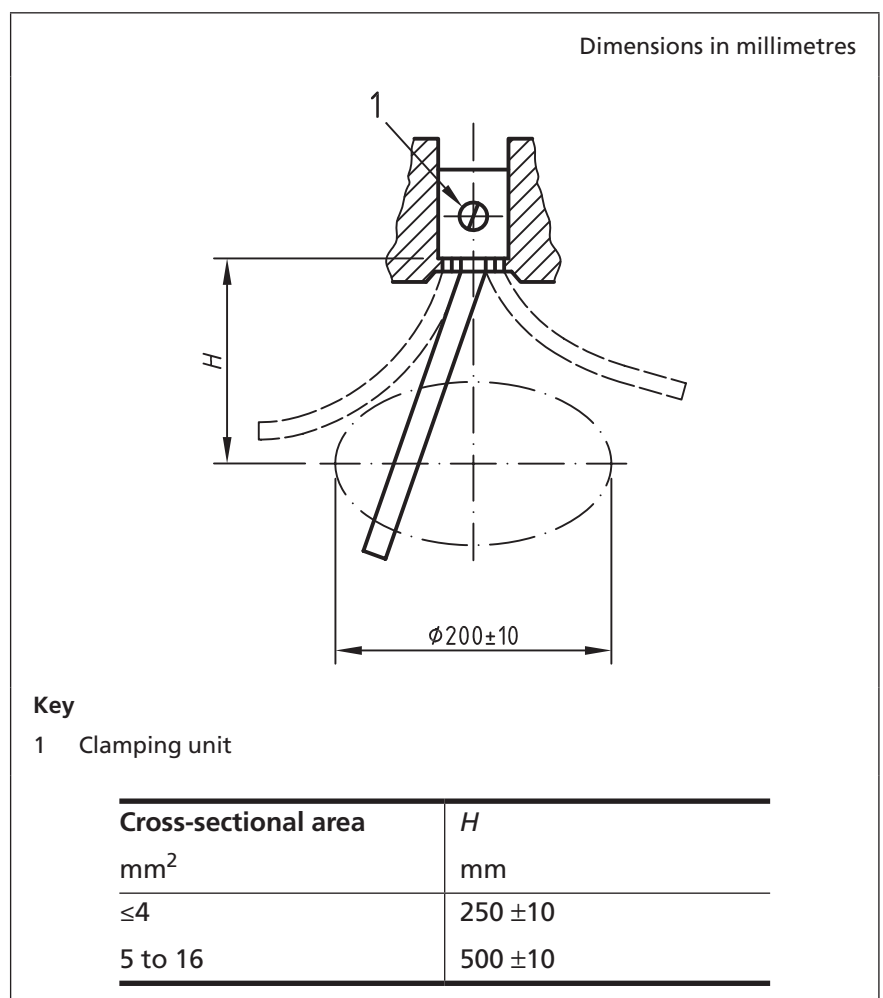

The conductor shall be moved in one direction at a constant speed of approximately one turn per 5 s.

During the circular motion, the conductor shall be subjected to a pull having a value shown in Table 4.

Table 4 Pull for terminal clamping test

Nominal conductor size mm ²	Pull $^{0}_{-5}\%$ N
0.75	20
1	30
1.25	35
1.5	40
2.5	50
4	50
6	60
10	80
16	90

14.2.6 Terminals with screw clamping shall be so designed that they clamp the conductor securely and between metal surfaces.

Conformity shall be checked by inspection. When terminals intended for the connection of rigid (solid or stranded) conductors are tested in accordance with the following method, the conductor shall not move noticeably in the terminal.

The test shall be first carried out with conductors of the smallest cross-sectional area and then with conductors of the largest cross-sectional area.

The terminals shall be fitted with rigid (solid or stranded) conductors as given in Table 2, the terminal screws being tightened with a torque equal to two-thirds of the torque shown in the appropriate column of Table 3.

If the screw has a hexagonal head with a slot, the torque applied shall be equal to two-thirds of the torque shown in column 3 of Table 3.

Each conductor shall then be subjected to a pull as given in Table 4, applied without jerks, for $60 \text{ s} \pm 5 \text{ s}$ in the direction of the axis of the conductor space.

If the clamp is provided for two or three conductors, the appropriate pull shall be applied consecutively to each conductor.

14.2.7 Terminals with screw clamping shall be so designed or placed that with the conductor properly inserted neither a rigid solid conductor nor a wire of a stranded conductor nor a strand of flexible conductor can slip out while the clamping screws or nuts are tightened.

NOTE This requirement does not apply to lug terminals.

Conformity shall be checked by inspection. When tested in accordance with the following method, no conductor shall have escaped from the retaining device of the clamping part.

The terminals shall be fitted with rigid (solid or stranded) conductors or flexible conductors having the largest cross-sectional area appropriate to the current rating of the accessory as specified in Table 2 and appropriate to the intended purpose of the terminal.

Terminals intended for the connection of rigid conductors shall be checked with solid conductors and with stranded conductors.

Terminals intended for the looping-in of two or three conductors shall be checked and shall be fitted with the maximum permissible number of conductors.

Before insertion into the clamping part of the terminal, conductors shall be straightened and stranded or flexible conductors may, in addition, be twisted to restore them approximately to their original shape.

The conductor or conductors shall be installed in the clamping part of the terminal in a manner appropriate to the terminal design. The clamping screw shall then be tightened with a torque equal to two-thirds of the torque shown in the appropriate column of Table 3.

14.2.8 Terminals with screw clamping shall be so fixed or located within the accessory that, when the clamping screws or nuts are tightened or loosened, the terminals shall not work loose from their fixings to the accessory.

NOTE 1 This does not mean that terminals should be so designed that their rotation or displacement is prevented, but any movement should be sufficiently limited so as to prevent non-conformity with this standard.

NOTE 2 The use of sealing compound or resin is considered to be sufficient for preventing a terminal from working loose, provided that:

- a) *the sealing compounds or resin is not subject to stress during normal use; and*
- b) *the effectiveness of the sealing compound or resin is not impaired by temperatures attained by the terminal under the most unfavourable conditions specified in this standard.*

Conformity shall be checked by inspection. When tested in accordance with the following method, terminals shall not work loose and there shall be no damage, such as breakage of the screws or damage to the head, slots, threads, washers or stirrups that will impair the further use of the terminals.

A solid rigid copper conductor of the largest cross-sectional area specified in Table 2 shall be placed in the terminal. The screws or nuts under test shall be tightened and loosened five times, by means of a suitable screwdriver or spanner, applying the appropriate torque shown in Table 3. A new conductor end shall be used each time the screw or nut is loosened.

Screws, or nuts of mantle terminals, which are tightened by means of a screwdriver, shall be tightened using the appropriate torque value shown in columns 1, 2 or 3 of Table 3.

Nuts of mantle terminals, tightened by means other than a screwdriver, shall be tightened using the appropriate torque value shown in column 4 of Table 3.

Other screws, or nuts, tightened by means other than a screwdriver, shall be tightened using the appropriate torque value shown in column 5 of Table 3.

Where a screw has a hexagonal head and a slot for tightening by means of a screwdriver and the torque values shown in columns 3 and 5 of Table 3 are the same, one test shall be made using a screwdriver applying the appropriate torque value shown in column 3 of Table 3.

If the values shown in columns 3 and 5 of Table 3 are different two tests shall be made as follows:

- a) first applying the appropriate torque value, shown in column 5 of Table 3, to the hexagonal head;
- b) then applying the appropriate torque value, shown in column 3 of Table 3, by means of a screwdriver.

NOTE 3 It is essential that the shape of the blade of the test screwdriver suits the head of the screw to be tested.

NOTE 4 It is essential that screws and nuts are not tightened in jerks.

14.2.9 Clamping screws or nuts of earthing terminals with screw clamping shall be designed to resist accidental loosening and it shall not be possible to loosen them without the aid of a tool.

NOTE In general, the designs of terminals shown in Figure 1, Figure 2, Figure 3, Figure 4 and Figure 5 provide sufficient resiliency to conform to this requirement; for other designs, special provisions, such as the use of an adequately resilient part which is not likely to be removed inadvertently, may be necessary.

Conformity shall be checked by inspection and, if necessary, by manual test.

14.2.10 Earthing terminals shall be of the materials specified in **15.5** so that there is minimal risk of corrosion resulting from contact between these parts and the copper of the earthing conductor, or any other metal that is in contact with these parts.

If the body of the earthing terminal is a part of a frame or box of aluminium alloy, precautions shall be taken to avoid the risk of corrosion resulting from contact between copper and aluminium or its alloys. The screw or nut shall be of brass or other metal no less resistant to corrosion.

NOTE Screws or nuts of plated steel withstanding the test of 25.2 are considered to be of metal no less resistant to corrosion than brass.

Conformity shall be checked by inspection.

14.2.11 For pillar terminals, the distance between the clamping screw and the end of the conductor, when fully inserted, shall be at least that specified in Figure 1.

NOTE The minimum distance between the clamping screw and the end of the conductor applies only to pillar terminals in which the conductor cannot pass right through.

For mantle terminals, the distance between the fixed part and the end of the conductor, when fully inserted, shall be at least that specified in Figure 5.

Conformity shall be checked by measurement, after a solid conductor of the largest cross-sectional area specified in Table 2 has been fully inserted and fully clamped.

14.2.12 Lug terminals shall be used only for accessories having a rated current of 45 A and over; if such terminals are provided, they shall be fitted with spring washers or equally effective locking means.

Conformity shall be checked by inspection.

14.3 Screwless terminals for copper conductors

14.3.1 Screwless terminals shall be provided with clamping units which allow the proper connection of conductors as specified by the manufacturer, having nominal cross-sectional areas as shown in Table 2.

NOTE 1 The terminals may be of the type suitable for the following:

- a) rigid (solid or stranded) copper conductors only;
- b) flexible copper conductors only; or
- c) both rigid (solid or stranded) and flexible copper conductors.

NOTE 2 This subclause is not applicable to accessories provided with any of the following:

- 1) screwless terminals requiring the fixing of special devices to the conductors before clamping them in the screwless terminals, for example flat push-on connectors;
- 2) screwless terminals requiring twisting of the conductors, for example those with twisted joints; or
- 3) screwless terminals providing direct contact to the conductors by means of edges or points penetrating the insulation.

Conformity shall be checked by inspection and by fitting conductors of the smallest and largest cross-sectional areas specified by the manufacturer. For screwless terminals intended to be suitable for the connection of both rigid and flexible copper conductors the tests given in 14.3 shall be carried out with rigid conductors first and then repeated with flexible conductors.

14.3.2 Screwless terminals shall be such that the conductor can be connected without special preparation.

NOTE Special preparation includes soldering of the wires of the conductor and use of terminal ends, but not reshaping of the conductor before its introduction into the terminal or the twisting of a flexible conductor to consolidate the end.

Conformity shall be checked by inspection.

14.3.3 Parts of screwless terminals mainly intended for carrying current shall be of the materials specified in 15.5.

NOTE Springs, resilient units, clamping plates and the like are not considered as parts mainly intended for carrying current.

Conformity shall be checked by inspection.

14.3.4 Screwless terminals shall be so designed that they clamp the specified conductors with sufficient contact pressure and without undue damage to the conductor.

The conductor shall be clamped between metal surfaces.

Conformity shall be checked by inspection and by the test of 14.3.9.

14.3.5 It shall be clear how the conductors are to be inserted and disconnected.

The intended disconnection of a conductor shall require an operation, other than a pull on the conductor, which can be effected manually with or without the help of a tool in normal use.

Openings for the use of a tool intended to assist the insertion or disconnection shall be clearly distinguishable from the opening intended for the conductor.

Conformity shall be checked by inspection and by the test of **14.3.9**.

14.3.6 Screwless terminals which are intended to be used for the interconnection of two or more conductors shall be so designed that:

- A1** a) during the connection or disconnection the conductors can be connected or disconnected either at the same time or separately;
- b) each conductor is introduced in a separate clamping unit (not necessarily in separate holes). **A1**

It shall be possible to clamp securely any number of conductors up to the maximum as designed.

Conformity shall be checked by inspection and by tests with the appropriate number of conductors of a specified size.

14.3.7 Screwless terminals shall be so designed that undue insertion of the conductor is prevented and adequate insertion is obvious.

Marking indicating the length of insulation to be removed before the insertion of the conductor into the screwless terminal shall be given on the accessory or in an instructional sheet which accompanies the accessory.

Conformity shall be checked by inspection and by the test of **14.3.9**.

14.3.8 Screwless terminals shall be properly fixed to the accessory.

When tested in accordance with **14.3.9**, screwless terminals shall not work loose when the conductors are inserted or disconnected during installation.

NOTE Covering with sealing compound without other means of locking is not sufficient. However, self-hardening resins may be used to fix terminals which are not subject to mechanical stress in normal use.

Conformity shall be checked by inspection **A1** and in addition, for maintenance free accessories, by testing in accordance with **14.5.3 A1**.

14.3.9 Screwless terminals shall withstand the mechanical stresses occurring in normal use. When tested in accordance with the following method, the conductors shall not have moved noticeably in the clamping unit, neither the terminals nor the clamping part shall have worked loose and the conductors shall show no deterioration, such that further use is impaired.

The test shall be carried out with uninsulated conductors on one screwless terminal of each sample.

The appropriate copper conductors shall be used, first conductors having the largest cross-sectional area, and then conductors having the smallest cross-sectional area specified in **14.3.1**.

Conductors shall be inserted and disconnected five times, new conductors being used each time, except for the fifth time, when the

conductors used for the fourth insertion shall be clamped at the same place. For each insertion, the conductors shall be either:

- a) pushed as far as possible into the terminal; or
- b) inserted so that adequate connection is obvious.

After each insertion, the conductor shall be subjected to a pull of 30_{-1}^0 N. The pull shall be applied without jerks, for $60 \text{ s} \pm 5 \text{ s}$, in the direction of the longitudinal axis of the conductor space.

During the application of the pull, the conductor shall not come out of the screwless terminal A_1 and the terminal shall not have become detached from the accessory A_1 .

14.3.10 Screwless terminals shall withstand, the electrical and thermal stresses occurring in normal use. When tested in accordance with the following methods, the screwless terminals shall show no changes likely to impair further use, e.g. cracks, deformation.

The following tests shall be carried out on five screwless terminals which have not been used for any other test.

Both tests shall be carried out with new copper conductors.

- a) The screwless terminals shall be loaded for $60 \text{ min} \pm 1 \text{ min}$ with an alternating current as given in Table 5 and connecting conductors approximately 1 m long, in accordance with 14.3.1, having the cross-sectional area as given in Table 5.

Table 5 Current for electrical and thermal stress test

Rated current	Test current	Nominal cross-sectional area of the conductor ^{A)}
A	A	mm ²
4	9.0	0.75
6	13.5	1
10	17.5	1.5
13	19.0	1.5
16	24.0	2.5
25	32.0	4
32	41.0	6
45	57.0	10
63	76.0	16

NOTE For accessories having rated current not given in this table, the test current should be determined by interpolation between the next lower and higher preferred rated currents and the cross-sectional area of the conductors should be chosen equal to the one specified for the next higher preferred rated current.

A_1) Where the maximum conductor size is marked on the accessory, this conductor size shall be used. A_1

The test shall be carried out on each clamping unit.

During the test the current shall not be passed through the accessory, but only through the terminals. Immediately after this period, the voltage drop across each screwless terminal shall be measured with rated current $_{-5}^0\%$ flowing.

In no case shall the voltage drop exceed 15 mV.

The measurements shall be made across each screwless terminal, as near as possible to the place of contact.

NOTE The samples may be prepared by the manufacturer.

During the preparation of the samples, care shall be taken to ensure that the behaviour of the terminal is not affected.

When performing the test and taking the measurements, care shall be taken to ensure that the conductors and the measurement equipment are not moved.

- b) The screwless terminals, after being subjected to the determination of the voltage drop in accordance with item a) shall be tested as follows.

During the test, a current equal to the test current value given in Table 5 shall be passed through the terminal.

The whole test arrangement, including the conductors, shall not be moved until the measurements of the voltage drop have been completed.

The terminals shall be subjected to 192 temperature cycles, each cycle having a duration of approximately 1 h and being carried out as follows:

- 1) with the current flowing for approximately 30 min; and
- 2) with no current flowing for approximately a further 30 min.

The voltage drop in each screwless terminal shall be determined in accordance with the test in item a) after every 24 temperature cycles and after the 192 temperature cycles have been completed. In no case shall the voltage drop exceed 22.5 mV.

On completion of the test, each screwless terminal shall be inspected using normal or corrected vision without additional magnification.

The mechanical strength test in accordance with 14.3.9 shall be repeated. All samples shall withstand the mechanical strength test.

14.4 Terminations for non-rewirable accessories

Non-rewirable accessories shall be provided with soldered, welded, crimped or similar terminations; screwed, screwless or "snap-on" terminals shall not be used. Crimped connections shall not be made onto pre-soldered flexible cords unless the soldered area is entirely outside the crimp.

For all these methods of termination, no more than one strand, or 5% of the total number of strands of the conductor, whichever is the larger, shall be fractured during connection.

When tested in accordance with the following method, there shall be no deterioration of the soldered, welded, crimped or similar joints impairing their further use.

Terminations shall be tested by exerting a pull of 30_{-1}^0 N for $60 \text{ s} \pm 5 \text{ s}$ in the longitudinal axis of the conductors in the normal plane of exit from the accessory.

14.5 Terminals for use within maintenance free accessories

14.5.1 For accessories classified according to Clause 4i) as maintenance free, the tests of 14.5.2 to 14.5.8 shall be performed in addition to the tests of 14.3.

14.5.2 Terminals shall have long-term connection capability.

Conformity shall be checked by the following test.

Terminals shall be subjected to a long-term connection test, at rated current, for a period of $1512 \text{ h} \pm 5 \text{ h}$. The terminal shall be connected and secured, as per the manufacturer's instructions, in such a way as to offer the most onerous conditions possible in normal use. The nominal cross-sectional area of the conductor used for the test shall be selected according to its rated current as specified in Table 5.

During the test the terminals shall be monitored with regard to the voltage drop and temperature rise. Measurements shall be taken at least every 168 h. At no point during the tests shall the temperature rise exceed the values specified in Clause 20 and the voltage drop shall not exceed 22.5 mV.

14.5.3 Terminals shall be resistant to the effects of vibration.

Conformity shall be checked by inspection and the following test.

A1 Accessories shall be subjected to a sinusoidal vibration. The severity shall be:

- a) duration: 30 min;
- b) amplitude: 0.35 mm;
- c) frequency range: 10 Hz, 55 Hz, 10 Hz;
- d) sweep rate: approximately one octave per minute. **A1**

Three tests shall be carried out on the terminals in the three major planes (through the terminal left to right, through the terminal top to bottom and through the terminal front to back). The test shall be carried out using conductors having the smallest and the largest nominal cross-sectional area according to its rated current as specified in Table 2.

Before each test, but after mounting the accessory on the vibration platform, a voltage drop test shall be carried out with a current of 1/10 of the rated current of the accessory. The voltage drop across the terminal shall not exceed 4 mV.

During the test a current of 1 A shall flow through the terminal and there shall be no contact interruption of a duration exceeding 0.02 μs .

After the test voltage drop across the terminal shall be measured with a current of 1/10 of the rated current of the accessory without disturbing the clamping unit, and shall not exceed 5.5 mV.

A1 The accessory shall have no changes from its original condition, such as cracks, deformation or loosened parts. Conformity shall be checked by inspection using normal or corrected vision without additional magnification. **A1**

14.5.4 Terminals shall withstand the effects of overloads and shall not cause ignition or damage to the mounting surface.

Conformity shall be checked by inspection and by the following tests.

Terminals shall be subjected to an overload of twice the rated current of the accessory for 1.5 h. The nominal cross-sectional area of the

conductor used for the test shall be selected according to its rated current as specified in Table 5. The conductors shall be connected in accordance with the manufacturer's instructions.

The following test shall be carried out in a draught-free environment.

The accessory shall be fixed to a plywood board having a nominal thickness of 24 mm and having a matt black finish. A temperature measuring device (see Note) shall be placed in the most unfavourable position on the board so that it is as close as possible to the hottest point of the accessory.

NOTE Temperature measuring devices may include, but are not limited to, thermocouples.

During the test the mounting surface shall not reach a temperature in excess of 90 °C.

After the test the accessory shall show no damage which:

- would impair safety;
- would prevent further use,

and shall be capable of conforming to the electrical strength requirements and the insulation resistance requirements of Clause 19.

14.5.5 Terminals shall be sufficiently resilient to the effects of thermal shock.

Conformity shall be checked by inspection and by the following tests.

The test shall be performed with a number of terminals, as appropriate to the accessory, installed according to the manufacturer's instructions. The accessory shall be wired with conductors of the rated cross-section for the terminals used. The conductors used shall be of a suitable type for the terminals, as specified by the manufacturer.

After verification of the voltage drop, which shall not exceed 4 mV when tested in accordance with Figure 11A, the assembly shall be subjected to a test current of 120 A/mm² of its rated cross-section for a duration of 1 s.

Figure 11A Arrangement for voltage drop test [New Figure]

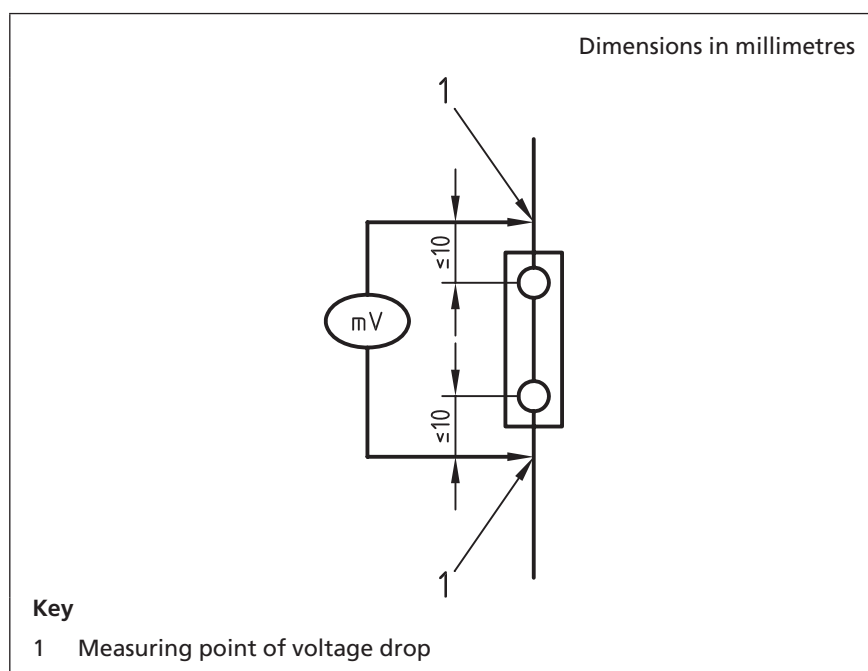

At the end of the test no damage that might impair further use shall have occurred to any part of the terminal block. After cooling down to ambient temperature and without any change in the arrangement, the accessory shall be subjected to a further voltage drop test. The voltage drop of the terminals shall not exceed 6 mV.

15 Screws, current-carrying parts and connections

15.1 Connections, electrical or mechanical, shall withstand the mechanical stresses occurring in normal use.

NOTE 1 Screws used exclusively for cord grip purposes are deemed to meet this requirement provided they meet the requirements of **16.2**.

Screws or nuts which transmit electrical contact pressure shall be of metal and shall be in engagement with a metal thread.

Conformity shall be checked by inspection. When tested by the following method, screws and nuts which are operated during the installation of the accessory shall show no signs of damage impairing further use of the screwed connections, e.g. breakage of screws or damage to the head slots rendering them unserviceable, or damage to threads, washers or stirrups.

NOTE 2 Methods for the verification of terminals are given in Clause **14**.

The screws or nuts shall be tightened and loosened as follows:

- a) ten times for screws in engagement with a thread of insulating material; or
- b) five times in all other cases.

Screws or nuts in engagement with a thread of insulating material shall be completely removed and reinserted each time.

The test shall be made by means of a suitable test screwdriver or a suitable tool, applying a torque as specified in **14.2.8**.

NOTE 3 Screws or nuts which are operated when assembling the accessory include screws for fixing covers or cover plates etc., but not connecting means for screwed conduits and screws for fixing the base of an accessory.

NOTE 4 It is essential that the shape of the blade of the test screwdriver suits the head of the screw to be tested. It is essential that screws and nuts are not tightened in jerks. Damage to covers is neglected.

15.2 For screws in engagement with a thread of insulating material which are used when mounting the accessory during installation, correct introduction into the screw hole or nut shall be ensured.

Conformity shall be checked by inspection.

NOTE The requirement with regard to correct introduction is met if introduction of the screw in a slanting manner is prevented, for example, by guiding the screw by the part to be fixed, by a recess in the female thread or by the use of a screw with the leading thread removed.

15.3 Electrical connections shall be so designed that contact pressure is not transmitted through insulating material other than ceramic or pure mica unless there is sufficient resiliency in the metallic parts to compensate for any possible shrinkage or yielding of the insulating material.

Conformity shall be checked by inspection and by manual test.

15.4 Screws and rivets which serve as electrical as well as mechanical connections shall be locked against loosening or turning.

In addition, the terminals of accessories containing earthing and neutral plug pins shall be either:

- a) formed as one piece with the pin; or
- b) permanently connected to the pin in such a way that efficient electrical connection is made that cannot work loose in use.

This connection shall not be made by means of a screw.

The contact for any fuse-link connected to the line terminal or termination shall be either:

- 1) formed in one piece with the fixed part of the terminal or termination; or
- 2) permanently connected to it in such a way that it cannot work loose in normal use.

The other contact for the fuse-link shall be similarly connected to the corresponding plug-pin. These connections shall not be made by means of screws.

The line terminal or termination shall provide for effectively clamping and securing conductors connected to it so that efficient electrical connection is made with any fuse-link.

Internal electrical connections to fuse-clips within accessories not containing terminals shall not be made by means of screws.

Conformity shall be checked by inspection.

NOTE 1 Spring washers may provide satisfactory locking.

NOTE 2 For rivets, a non-circular shank or an appropriate notch may provide satisfactory locking.

NOTE 3 A sealing compound which softens on heating provides satisfactory locking only for screw connections not subjected to torsion in normal use.

15.5 Current-carrying parts, including those of terminals (also earthing terminals), shall be of a metal having, under the conditions occurring in the equipment, mechanical strength, electrical conductivity and resistance to corrosion adequate for their intended use.

Conformity shall be checked by inspection and by the appropriate tests of this standard.

15.6 Current-carrying parts which may be subjected to mechanical wear shall not be made of steel which has an electroplated coating.

Conformity shall be checked by inspection.

15.7 Metals showing a great difference of electrochemical potential with respect to each other under moist conditions, such that corrosion might result, shall not be used in contact with each other.

Conformity shall be checked by inspection.

NOTE This requirement does not apply to screws, nuts, washers, clamping plates and similar parts of terminals.

15.8 Thread-forming screws shall not be used for the connection of current-carrying parts.

NOTE Thread-forming screws may be used to provide earthing continuity provided that it is not necessary to disturb the connection in normal use and at least two screws are used for each connection.

Conformity shall be checked by inspection.

16 Provisions for cables and cords

16.1 Accessories intended for fixed installations shall have terminals as specified in Clause 14. These terminals shall be suitable for the connection of solid or stranded copper conductors of appropriate cables conforming to BS 6004, BS 6007, BS 6500, BS 7211 or those designated by the manufacturer.

The entry to the accessory, for the installation of insulated conductors, shall be designed so that they may be connected without exposing the bared conductors in accordance with Clause 10.

The entry shall also be designed so that it causes no damage to the insulation of the conductors or to the sheath of the cable.

Conformity shall be checked by inspection.

16.2 Accessories intended for use with a flexible cord or cable shall be so designed that an appropriate 2-core or 3-core flexible cord or cable, either conforming to BS 6500:2000+A3, Tables 11, 12, 13, 26 or 27, or that designated by the manufacturer, may enter the accessory through a suitable hole, groove or gland. The entry shall accept the maximum dimensions of the outer sheath of the appropriate flexible cord or cable, having conductors of the cross-sectional area specified in Table 2, according to the rating of the accessory. The entry shall be so shaped as to prevent damage to the flexible cord or cable. An anchorage shall be provided so that the conductors are relieved from strain, including twisting, where they are connected to the terminals or terminations.

The anchorage shall contain the sheath and shall be either of insulating material or, if of metal, shall be provided with an insulating lining fixed to the metal parts. Anchorages shall anchor the cord or cable securely to the accessory. Rewirable accessories shall be designed as follows:

- a) the anchorage cannot be released from the outside without the use of a tool; and
- b) clamping the cord or cable does not require the use of a special purpose tool.

All accessories shall be designed as follows:

- 1) anchorage restraint is not effected by a metal part bearing directly on the flexible cord or cable; and
- 2) at least one part of the anchorage is securely fixed to the accessory or its mounting box.

Anchorage clamping screws shall not be used to secure any other components unless the accessory is rendered obviously incomplete if the component is omitted or is replaced in an incorrect position, or the component intended to be fixed cannot be removed without further use of a tool.

Conformity shall be checked by inspection. When tested in accordance with the following method, the flexible cord or cable shall not be displaced by more than 2 mm. The insulation of the flexible cord or cable shall not be damaged.

NOTE Flashover or breakdown between the conductors of the flexible cord or cable is considered to indicate damage.

Any neon indicator, electronic component or other voltage sensitive device shall be isolated before commencing the test.

Rewirable accessories shall be fitted with a 2-core flexible cord having a nominal conductor cross-sectional area of 0.5 mm² as given in BS 6500:2000+A3, Table 26, or the minimum designated by the manufacturer. The conductors shall be introduced into the terminals and the terminal screws tightened just sufficiently to prevent the conductors changing their positions. The anchorage shall be used in the normal way, the clamping screws, if any, being tightened to a torque of two-thirds of that given in Table 3. The assembly shall then be left untouched for a minimum of 24 h.

After this preparation, it shall not be possible to push the flexible cord or cable into the accessory, or into its box to such an extent as to impair safety, or so that the anchorage is loosened.

The flexible cord shall then be pulled 25 times with a force of $30^{+0.6}_0$ N. The cord shall be pulled momentarily in the most unfavourable position without jerks. Immediately afterwards, the flexible cord shall be subjected for 60^{+5}_0 s to a torque of 0.15 N·m $\pm 5\%$, as near as practicable to the cord entry.

This test shall then be repeated, the accessory being fitted with the largest appropriate flexible cord or cable specified in 16.2, the forces for the pull and torque test being those given in Table 6.

Table 6 Pull and torque tests for flexible cord and cable anchorages

Nominal conductor size mm ²	Pull $\pm 2\%$ N	Torque $\pm 10\%$ N·m
0.5	30	0.15
0.75	35	0.15
1.0	40	0.15
1.25	45	0.15
1.5	45	0.15
2.5	55	0.20
4	65	0.25
6	85	0.30
10	100	0.35
16	120	0.40

For non-rewirable accessories, the test shall be carried out with the flexible cable or cord with which the accessory is supplied, and using the loads specified in Table 6. The conductors of the flexible cord shall be severed at the point of termination prior to the test.

NOTE The manufacturer may prepare the sample for the laboratory prior to submitting the sample for test.

For the measurement of longitudinal displacement a mark shall be made on the sheath whilst it is subjected to the pull at a distance of approximately 20 mm from the anchorage before starting the tests. After the test the displacement of the mark in relation to the anchorage shall be measured whilst the cord or cable is again subjected to the pull. A test voltage of 3 750 V ± 75 V a.c. shall be applied for 60^{+5}_0 s between the conductors.

16.3 Non-rewirable portable accessories shall be provided with an appropriate 2-core or 3-core flexible cord or cable either conforming to BS 6500 or conforming to the requirements of the equipment specification as designated by the manufacturer. The method of connection within the accessory shall conform to **14.4**. The retention of the flexible cord shall withstand the conditions of normal use and shall be such as to prevent excessive bending where it enters the accessory.

16.4 Conformity shall be checked by inspection. When tested in accordance with the following method using apparatus as shown in Figure 12, there shall be no interruptions of the current passing through the conductors and no short circuit between them during the test.

After the test, the sample shall show no damage other than breakage of no more than 10% of the total number of conductor strands in any core, provided they have not pierced the insulation.

The accessory shall be fixed to the oscillating member of the apparatus so that when this is vertical the axis of the flexible cord at the point of entry is vertical and passes through the axis of oscillation. Accessories with flat flexible cords shall be mounted so that the major axis of the section is parallel to the axis of oscillation.

The flexible cable or cord shall be loaded with a mass such that the force applied is as follows:

- a) $20^{+0.4}_0$ N for accessories with cables or cords having a nominal cross-sectional area exceeding 0.75 mm^2 ; or
- b) $10^{+0.2}_0$ N for other accessories.

The distance between the point of entry to the accessory and the axis of oscillation shall be adjusted so that the weight makes the minimum lateral movement as the oscillating member moves.

A current equal to the rated current of the accessory $_{-5}^0\%$ or the following current, whichever is the lower, shall be passed through the conductors:

- 1) $16 \text{ A} \pm 0.2 \text{ A}$ for accessories with cables or cords having a nominal cross-sectional area exceeding 0.75 mm^2 ;
- 2) $10 \text{ A} \pm 0.2 \text{ A}$ for accessories with cables or cords having a nominal cross-sectional area of 0.75 mm^2 ;
- 3) $2.5 \text{ A} \pm 0.2 \text{ A}$ for accessories with cords having a nominal cross-sectional area less than 0.75 mm^2 .

The voltage between the conductors shall be approximately equal to the rated voltage of the accessory. If an earthing conductor is incorporated in the flexible cable or cord it shall be connected at one end to the neutral conductor for the purposes of this test.

The oscillating member shall be moved backwards and forwards through an angle of approximately 90° , $45^\circ \pm 3^\circ$ on either side of the vertical, the number of flexings being 10 000 at a rate of 60^{+0}_{-10} per minute. After 5 000 flexings, accessories with cords of circular section shall be turned through $90^\circ \pm 5^\circ$ about the cord entry centre line.

NOTE A flexing is one movement through $90^\circ \pm 5^\circ$, either backwards or forwards.

Figure 12 Apparatus for flexing test

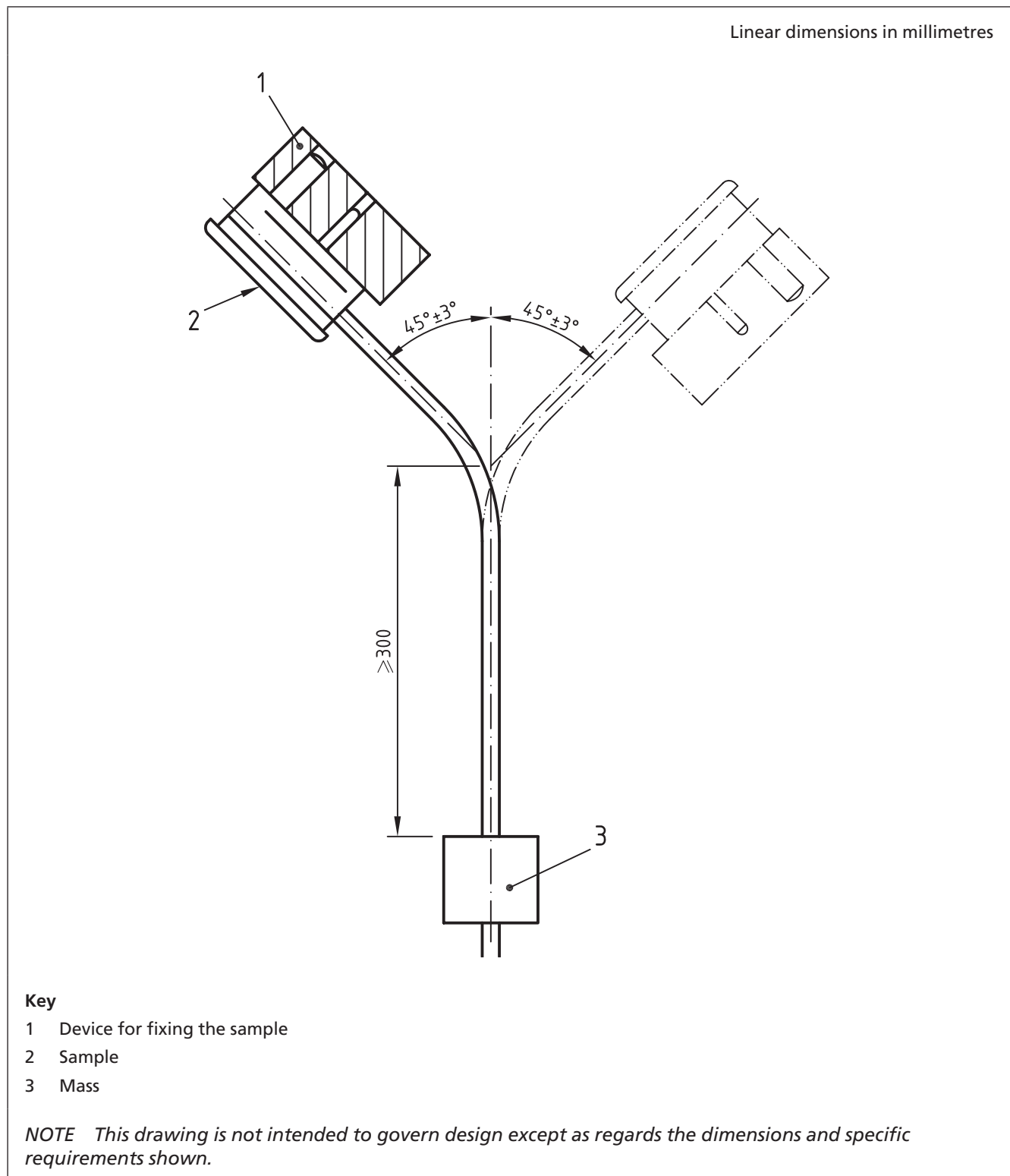

17 Resistance to ageing

17.1 Accessories shall be resistant to ageing.

When tested in accordance with the following method, the samples shall show no cracks formed as a result of the test, visible to normal or corrected vision without magnification, and shall subsequently pass the remaining tests in the series as specified in 6.3b).

Accessories, mounted as in normal use, shall be subjected to a test in a heating cabinet with an atmosphere having the composition and pressure of the ambient air, and ventilated by natural circulation or fan assistance.

17.2 Accessories other than ordinary shall be tested after having been mounted and assembled as specified in 18.1.2.1.

The temperature in the cabinet shall be $70\text{ °C} \pm 5\text{ °C}$.

The samples shall be kept in the cabinet for 168^{+2}_0 h.

NOTE 1 The use of an electrically heated cabinet is recommended.

NOTE 2 Natural air circulation may be provided by holes in the walls of the cabinet.

After the treatment, the samples shall be removed from the cabinet and kept at room temperature and relative humidity for 1 h; following which they shall be examined for damage.

18 Resistance to harmful ingress of water and resistance to humidity

18.1 Resistance to ingress of water

18.1.1 General

The enclosure of accessories other than ordinary shall provide a degree of protection against harmful ingress of water in accordance with their classification.

When tested in accordance with 18.1.2.2 and 18.1.2.3, the samples shall withstand an electric strength test as specified in 19.3 and inspection shall show that water has not entered the samples to any appreciable extent and has not reached live parts.

18.1.2 Methods of test

18.1.2.1 Surface-type accessories shall be mounted on a vertical surface with any open drain hole in the lowest position.

Flush-type and semi-flush-type accessories shall be fixed vertically in an appropriate box which is placed in a recess in a block of hardwood.

Unenclosed accessories, e.g. panel-mounted, shall be tested under a simulation of conditions of normal use, taking into account the manufacturer's instructions.

Accessories with screwed glands or membranes shall be fitted and connected with cables within the connecting range specified in Table 2. Mounting screws for boxes or enclosures and screws for fixing accessories to boxes or enclosures shall be tightened with a torque equal to two-thirds of the values given in Table 3.

Screwed glands shall be tightened with a torque equal to two-thirds of that applied during the test of **21.3.8**.

Parts which can be removed without the aid of a tool shall be removed.

NOTE Glands are not filled with sealing compound.

18.1.2.2 Splash-proof accessories shall be subjected to the test specified for the degree of protection IPX4, in accordance with BS EN 60529.

18.1.2.3 Jet-proof accessories shall be subjected to the test specified for the degree of protection IPX5, in accordance with BS EN 60529.

18.2 Resistance to humidity

Accessories shall be resistant to humidity which may occur in normal use.

When tested in accordance with the following method followed immediately by the measurement of the insulation resistance and by the electric strength test specified in Clause **19**, the samples shall show no signs of damage.

If the accessory has inlet openings, they shall be left open. If the accessory has knock-outs, one of them shall be opened.

Parts which can be removed without the aid of a tool shall be removed and subjected to the humidity treatment with the main part; any spring lids shall be kept open during treatment. The humidity treatment shall be carried out in a humidity cabinet containing air with a relative humidity maintained between 85% r.h. and 95% r.h.

The temperature of the air in which the samples are placed shall be maintained within ± 2 °C of an appropriate temperature t between 20 °C and 30 °C.

Before being placed in the humidity cabinet, the samples shall be brought to a temperature between t and $t + 4$ °C.

The samples shall be kept in the cabinet for the following times:

- a) 48^{+1}_0 h for ordinary accessories; and
- b) 168^{+3}_0 h for accessories other than ordinary.

NOTE 1 In most cases, the samples may be brought to the specified temperature by keeping them at this temperature for at least 4 h before the humidity treatment.

NOTE 2 A relative humidity between 85% r.h. and 95% r.h. can be obtained by placing in the humidity cabinet a saturated solution, having a sufficiently large contact surface with the air, of sodium sulfate (Na_2SO_4) or potassium nitrate (KNO_3) in water.

NOTE 3 In order to achieve the specified conditions within the cabinet, it is necessary to ensure constant circulation of the air within the cabinet. In general, a cabinet which is thermally insulated should be used.

19 Insulation resistance and electric strength

19.1 The insulation resistance and the electric strength of accessories shall be adequate.

The insulation resistance and electric strength shall be tested in accordance with **18.2**, followed immediately by **19.2** and **19.3** in the humidity cabinet or in the room in which the samples were brought to the prescribed temperature, after reassembly of those parts which

may have been removed without the aid of a tool. When tested in accordance with **19.2**, the insulation resistance shall be as given in **19.2**. When tested in accordance with **19.3**, no flashover or breakdown shall occur during the test.

Any neon indicator, electronic component or other voltage sensitive device shall be isolated before commencing the test.

19.2 The insulation resistance shall be measured with a d.c. voltage of 500^{+250}_0 V applied, the measurement being made $60\text{ s} \pm 5\text{ s}$ after application of the voltage.

The insulation resistance shall be not less than the following:

- a) $5\text{ M}\Omega$ between parts of opposite polarity;
- b) $5\text{ M}\Omega$ between parts of opposite polarity connected together and other parts insulated therefrom, including earthed metal; and
- c) $2\text{ M}\Omega$ across open switch contacts (where applicable).

19.3 The insulation shall be subjected for $60\text{ s} \pm 5\text{ s}$ to a voltage of sinusoidal waveform having a nominal frequency of 50 Hz or 60 Hz.

The value of the test voltage shall be not less than eight times the maximum rated voltage of the accessory with a minimum of 500 V, and shall be applied as follows:

- a) between live parts of opposite polarity; and
- A1 b) between parts of opposite polarity connected together and:
 - 1) other parts insulated therefrom, including earthed metal;
 - 2) a sheet of metal foil in contact with the entire accessible external surface. A1

Initially, not more than half the specified voltage shall be applied, then it shall be raised rapidly to the full value.

The high-voltage source used for the test shall be so designed that, when the output terminals are short-circuited after the output voltage has been adjusted to the appropriate test voltage, the output current is not less than 200 mA. Any overcurrent protection shall not operate at a current less than 100 mA.

The r.m.s. value of the test voltage applied shall be measured within $\pm 3\%$. Glow discharges without drop in voltage shall be ignored.

20 Temperature rise

20.1 General

Accessories shall be so constructed that the temperature rise in normal use is in accordance with **20.4.3**. Accessories shall be tested in accordance with **20.2**, **20.3** and **20.4**.

Accessories shall be prepared for test in accordance with **20.2** and **20.3**, and as follows.

To ensure normal cooling of terminals and/or terminations, conductors connected to them shall have a length of at least 1 m.

Screws or nuts of rewirable terminals shall be tightened with a torque equal to two-thirds of the torque shown in the appropriate column of Table 3.

In a fused accessory, as defined in 3.9, the fuse shall be replaced by a link of negligible impedance as specified in 13.7.

20.2 Test conductors

20.2.1 Test conductors shall be of the nominal cross-sectional area given in Table 6A, appropriate to the current-rating and application of the accessory being tested.

Table 6A Cross-sectional areas for copper conductors for temperature-rise test

Rated current	Rigid conductors (solid or stranded) nominal cross-sectional area ^{A)} mm ²	Flexible conductors (cords or cables) nominal cross-sectional area ^{A)} mm ²
A		
Up to 6	1.5	0.75
Above 6 up to and including 10	1.5	1.0
Above 10 up to and including 16	2.5	1.5
Above 16 up to and including 25	4.0	2.5
Above 25 up to and including 32	6.0	4.0
Above 32 up to and including 45	10.0	6.0
Above 45 up to and including 63	16.0	10.0

^{A)} For screwless terminals, where the maximum conductor size is marked on the accessory in relation to the rated current, the marked maximum conductor size applies. 

20.2.2 For fixed accessories, solid or stranded rigid conductors, in accordance with 20.2.1, shall be fitted, as in normal use, to represent the fixed supply wiring.

If such accessories have additional provision for external connection to other equipment, flexible cords or cables, in accordance with 20.2.1, shall be fitted to the terminals for such external connection.

20.2.3 For portable accessories intended to be connected by flexible cords or cables, these shall conform to 20.2.1 and shall be fitted as in normal use.

20.2.4 Cables or cords used for tests shall conform to BS 6004 or BS 6500, as appropriate. For fixed accessories, in accordance with 20.2.2, the fixed supply wiring shall be represented by single core insulated and sheathed copper conductors.

20.2.5 Non-rewirable portable accessories shall be tested with the flexible cord as supplied.

20.2.6 For accessories having no provision for cords or cables, e.g. adaptors other than those conforming to BS 546 or to BS 1363-3, connection for test shall be by means appropriate to the intended use of the accessory.

20.3 Mounting procedures

20.3.1 Surface mounted fixed accessories shall be mounted as in normal use, with any accompanying mounting blocks or backplates fixed to a vertical plywood board having a nominal thickness of 24 mm and having a flat surface extending at least 150 mm in each direction beyond the extremities of the accessory.

20.3.2 Flush mounted fixed accessories shall be mounted in an appropriate flush mounting box placed in a block of wood simulating the conditions of normal use so that the front edges of the box are between 2.5 mm and 5 mm below the front surface of the block. The size of the block shall be such that there is a minimum of 25 mm of wood surrounding the box on all sides and at the back.

20.3.3 Portable accessories, other than plugs or adaptors, intended to be connected by flexible cords or cables shall be placed in position as in normal use, on a horizontal plywood board having a nominal thickness of 24 mm and having a surface extending at least 150 mm in each direction beyond the extremities of the accessory.

20.3.4 Plugs and adaptors having provision for connection of flexible cords, shall be inserted into a corresponding socket-outlet which shall be mounted as specified in **20.3.1**, **20.3.2** or **20.3.3**, as appropriate.

If suitable sockets are available as described in all three subclauses, then **20.3.2** shall apply.

20.3.5 Accessories as described in **20.2.6** shall be prepared for test as appropriate to their design, applying the requirements of **20.3.1**, **20.3.2**, **20.3.3** or **20.3.4**, as relevant.

20.3.6 Where supply cables enter into mounting boxes or similar enclosures for the tests of **20.3.1** and **20.3.2**, the entry shall be by way of normal knockouts or cable entries and appropriate grommets or similar means shall be used to seal the entry and to prevent the circulation of air.

The outer sheath shall be removed from the insulated cores to within 20 mm of the point of entry of the cable into the box or enclosure.

20.4 Testing procedures

20.4.1 Temperature rise shall be determined by means of fine-wire thermocouples, having wires not exceeding 0.3 mm in diameter, so chosen and positioned that they have minimum effect on the temperature of the part under test. Thermocouples shall be attached by soldering, or by means of a mixture of equal parts of resin adhesive and zinc oxide, or by other equally effective means.

If soldering is used, care shall be taken to ensure that heat from the soldering process does not affect the performance of the accessory and that no electrical connections are bridged by solder.

20.4.2 All tests shall be carried out as follows:

- a) in a draught-free environment;
- b) at an ambient temperature of $20\text{ }^{\circ}\text{C} \pm 5\text{ }^{\circ}\text{C}$;
- c) for a period of 60^{+5}_0 min;
- d) at any convenient voltage up to rated +10%;
- e) at a test current greater than the rated current calculated as shown in Table 7.

Table 7 Multiplying factor for the temperature rise test

Rated current of accessory	Multiplying factor
Up to and including 10 A	1.25
Over 10 A up to and including 25 A	1.2
Over 25 A	1.1

NOTE The test current is the rated current of the accessory multiplied by the multiplying factor with a tolerance on the test current of $\pm 5\%$.

20.4.3 The temperature rise of the accessory under test shall not exceed the following limits:

- at any terminal or termination: 52 K;
- at the accessible external surface: 52 K.

NOTE These values take account of an uncertainty of temperature measurement of $\pm 2\text{ }^{\circ}\text{C}$.

21 Mechanical strength

21.1 General

Accessories shall have adequate mechanical strength and shall be so constructed as to withstand such handling as may be expected in normal use.

Conformity shall be checked by the following tests:

- surface mounted fixed accessories in accordance with **21.3.1**;
- flush mounted fixed accessories in accordance with **21.3.2**;
- plugs in accordance with **21.3.3**;
- single and twin portable socket-outlets in accordance with **21.3.4**;
- portable socket-outlets with more than two outlets in accordance with **21.3.5**;
- adaptors in accordance with **21.3.6**;
- portable accessories intended to be left connected to the supply or to the appliance when not in use in accordance with **21.3.7**; and
- screwed glands in accordance with **21.3.8**.

21.2 Test apparatus

21.2.1 For fixed accessories the apparatus shall be as shown in Figure 13, Figure 14 and Figure 15 and it shall be constructed as follows.

The striking element shall have a hemispherical face of 10 mm ± 0.5 mm radius, made of polyamide having a Rockwell hardness of $85 \leq \text{HR} \leq 110$, or hornbeam, and shall have a mass of 150 g ± 1 g.

It shall be rigidly fixed to the lower end of a steel tube with an external diameter of approximately 9 mm and a wall thickness of approximately 0.5 mm. The tube shall be pivoted at its upper end in such a way that it swings only in a vertical plane.

The axis of the pivot shall be 1 000 mm \pm 1 mm above the axis of the striking element.

The design of the apparatus shall be such that a force between 1.9 N and 2.0 N has to be applied to the face of the striking element to maintain the tube in a horizontal position.

The mounting support shall have a mass of 10 kg \pm 1 kg and shall be mounted on a rigid frame by means of pivots. The frame shall be fixed on a solid wall.

The design of the mounting shall be such that:

- a) the sample can be so placed that the point of impact lies in the vertical plane through the axis of the pivot;
- b) the sample can be removed horizontally and turned about an axis perpendicular to the surface of the plywood;
- c) the plywood can be turned about a vertical axis.

The samples shall be mounted so that the point of impact lies in the vertical plane through the axis of the pivot.

The striking element shall be allowed to fall from a height as follows:

- 1) 75 $_{-5}^0$ mm for those parts of covers which are recessed to a depth of at least one-sixth of the largest dimension of the recessed part;
- 2) 100 $_{-5}^0$ mm for flat surfaces of cover plates of flush-type accessories;
- 3) 150 $_{-5}^0$ mm for adaptors (see 21.3.6);
- 4) 200 $_{-5}^0$ mm for parts projecting from the mounting surfaces (e.g. rims exceeding 200 mm from the walls) of cover plates of flush-type accessories and for boxes of surface types;
- 5) 250 $_{-5}^0$ mm for boxes of types other than ordinary.

NOTE 1 The height of the fall is the vertical distance between the position of a checking point, when the pendulum is released, and the position of that point at the moment of impact.

The checking point shall be marked on the surface of the striking element where the line through the point of intersection of the axes of the steel tube of the pendulum and the striking element and perpendicular to the plane through both axes, meet the surface.

NOTE 2 Theoretically the centre of gravity of the striking element should be the checking point. As the centre of gravity in practice is difficult to determine, the checking point is chosen as described above.

21.2.2 For portable accessories, other than plugs or adaptors, the apparatus shall be as shown in Figure 16.

21.2.3 For plugs and adaptors the apparatus shall be as shown in Figure 17.

Figure 13 General view of an example of impact test apparatus

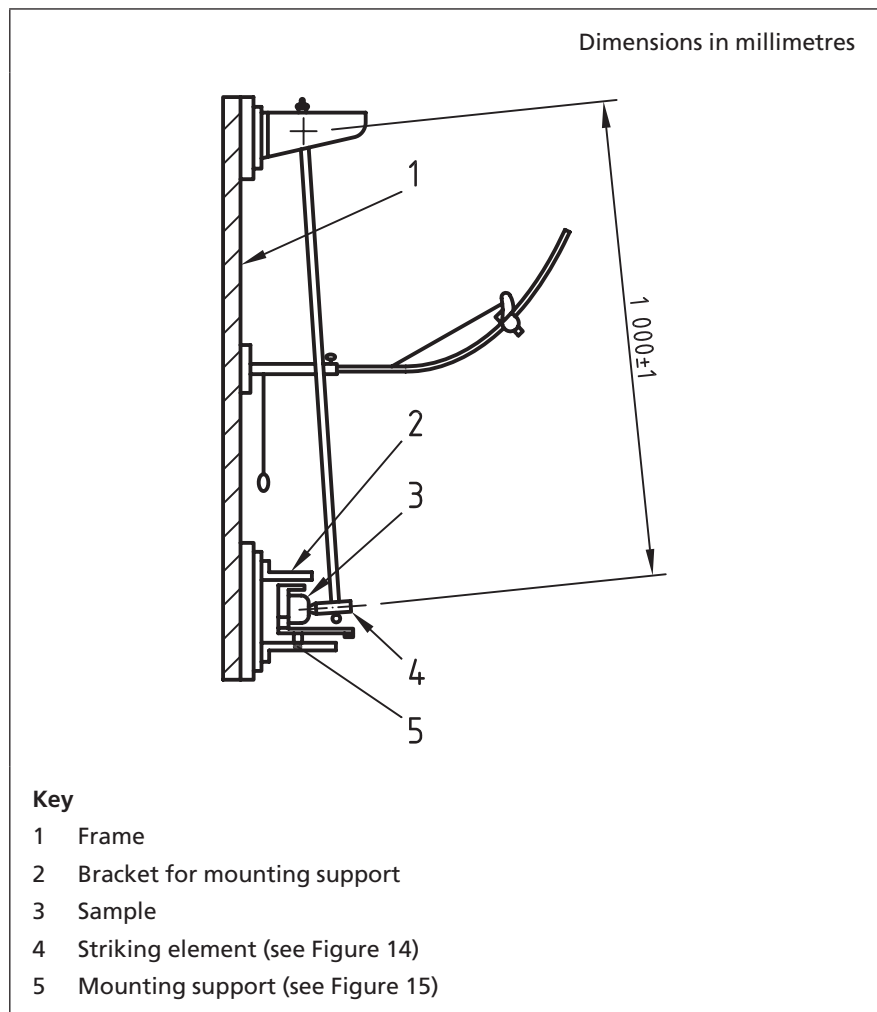
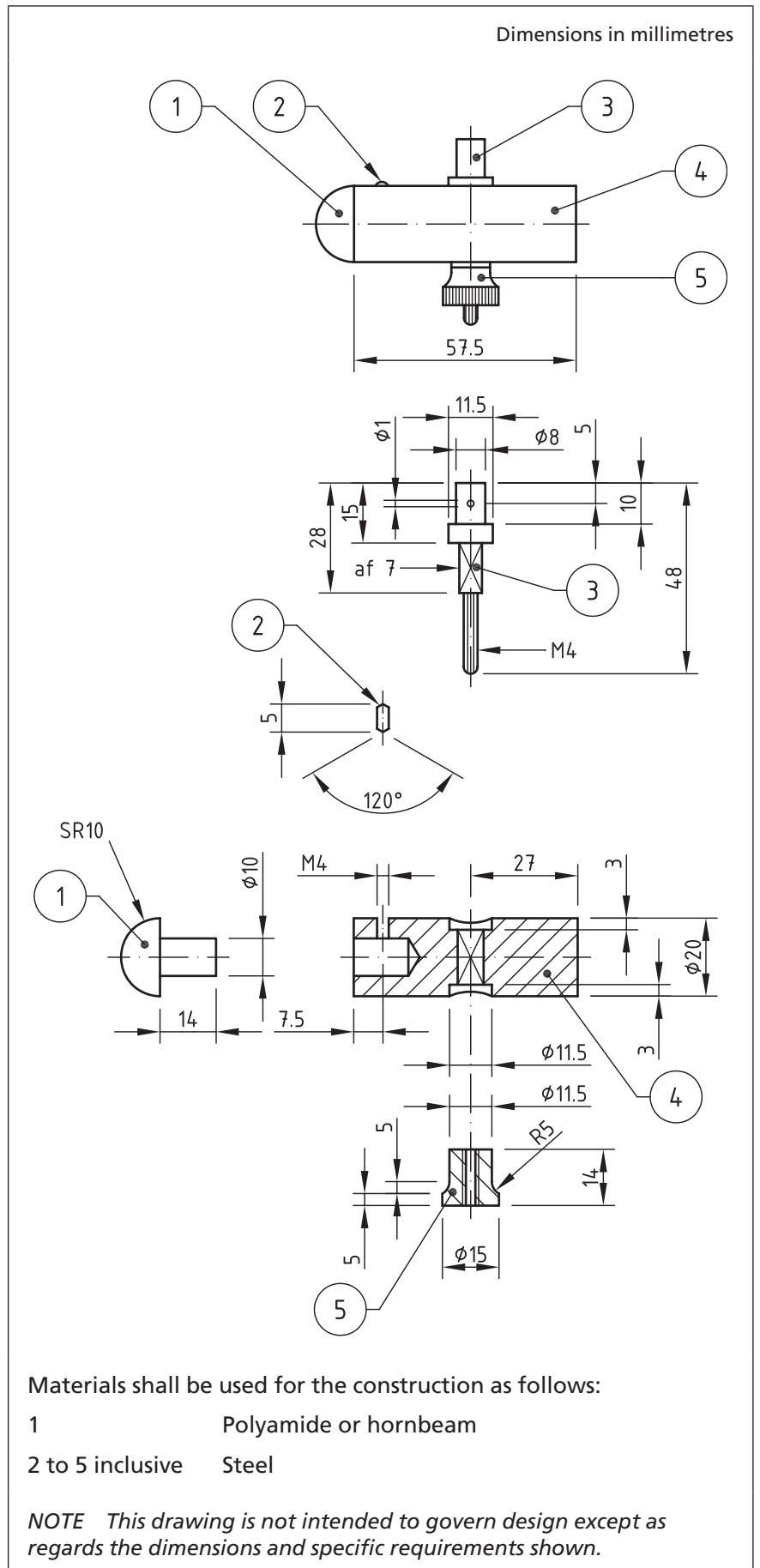

Figure 14 Constructional details of striking element



Licensed copy: Lee Shau Kee Library, HKUST, Version correct as of 03/01/2015, (c) The British Standards Institution 2014

Figure 15 Constructional details of mounting support for test samples

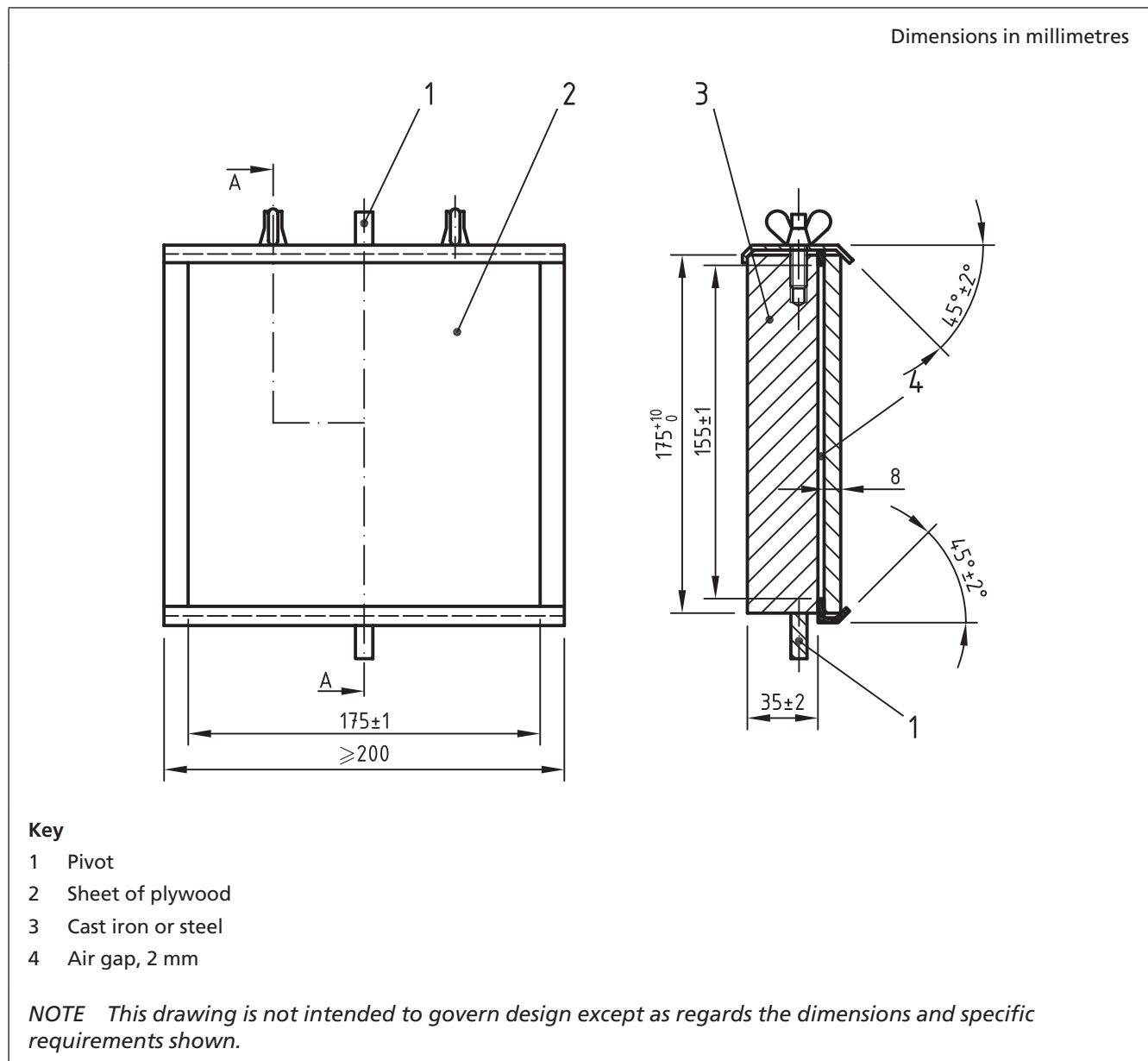

Figure 16 Arrangement for mechanical strength test for portable accessories other than plugs or adaptors

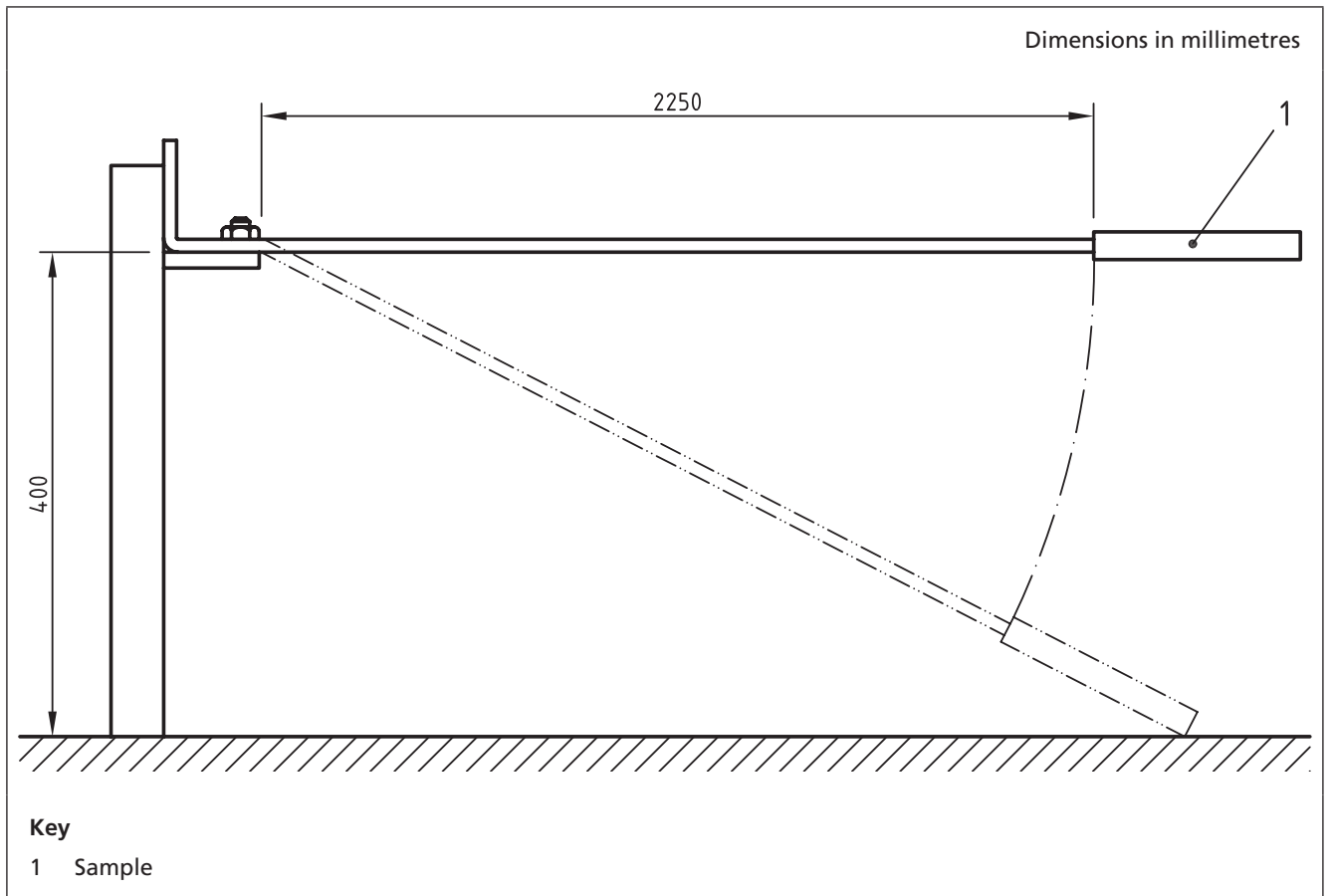
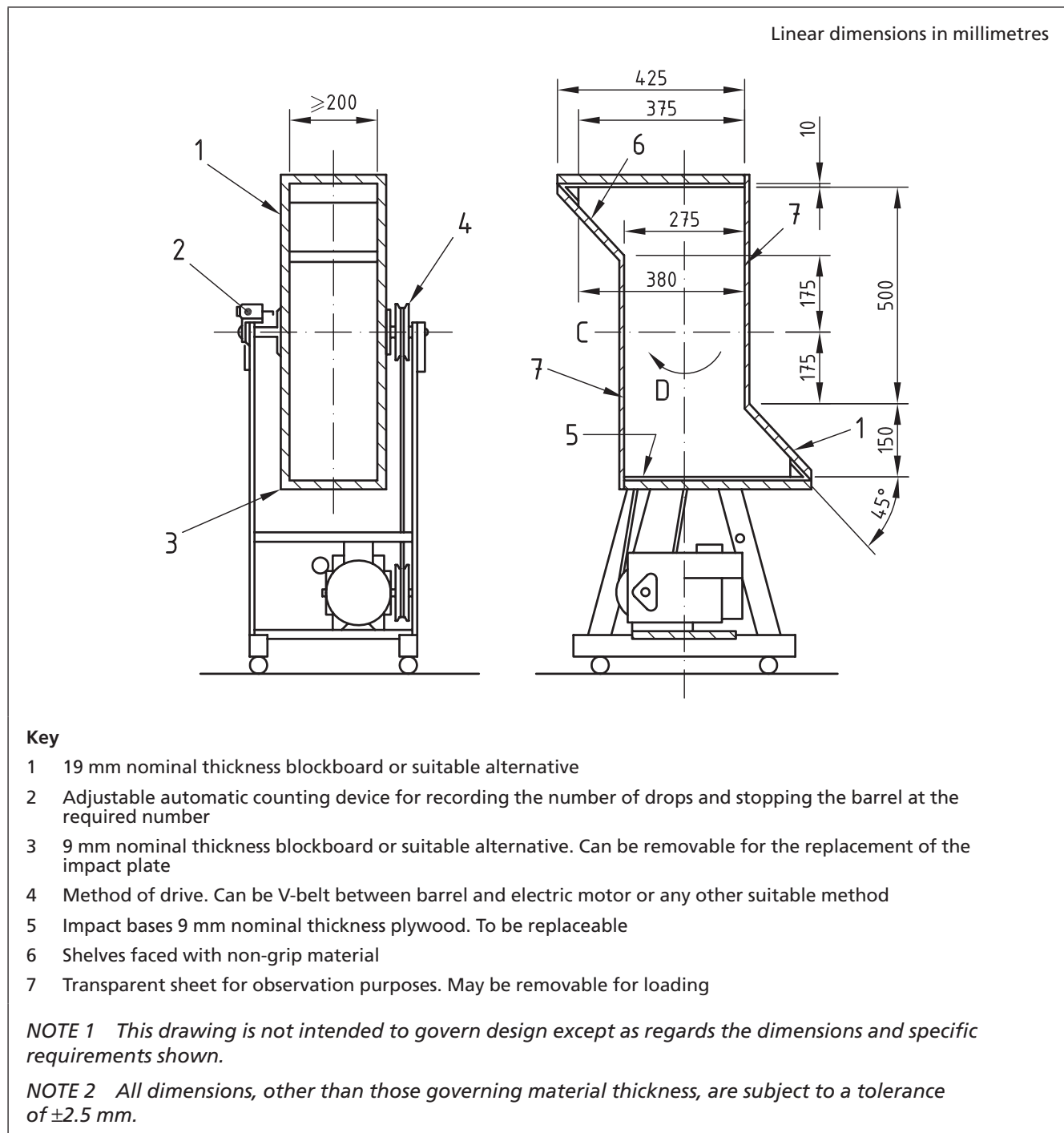

Figure 17 Tumbling barrel



21.3 Testing procedures

21.3.1 Surface mounting fixed accessories shall be mounted, as in normal use, with any accompanying mounting blocks or backplates, fixed to a vertical plywood board, having the approximate dimensions of 8 mm thick and 175 mm square, secured at its top and bottom edges to a rigid bracket as shown in Figure 15.

Ten blows shall be applied to points evenly distributed over the accessory. Any lens incorporated in an accessory shall receive one blow of the hammer at a point approximately at its centre. If the accessory

has a switch actuating member, one of the ten blows of the hammer shall be applied to the switch actuating member.

21.3.2 Flush mounted fixed accessories shall be mounted in an appropriate flush mounting box, in a recess provided in a block of hornbeam or similar material, with the rear of the accessory front plate flush with the surface of the block. The box shall be mounted simulating the conditions of normal use, so that the front edges of the box are between 2.5 mm and 5 mm below the front surface of the block. If wood is used for the block the direction of the wood fibres shall be perpendicular to the direction of impact. The block shall be fixed to a vertical plywood board, having the approximate dimensions 8 mm thick and 175 mm square, secured at its top and bottom edges to a rigid bracket as shown in Figure 15.

Ten blows shall be applied to points evenly distributed over the accessory. Any lens incorporated in an accessory shall receive one blow of the hammer at a point approximately at its centre. If the accessory has a switch actuating member, one of the ten blows of the hammer shall be applied to the switch actuating member.

21.3.3 Plugs shall be fitted with 2-core or 3-core PVC sheathed flexible cords, appropriate to the design and current rating of the accessory, as given in BS 6500:2000+A3, Table 27. Terminals and cover screws shall be tightened with the torque given in Table 3. The length of the flexible cord, measured from the nearest edge of the accessory and with precoiled flexible cords extended before measurement, shall be 150 mm \pm 5 mm. Non-rewirable plugs shall be tested with the flexible cord as delivered, but cut to a length of 150 mm \pm 5 mm.

Plugs shall be tested in the tumbling barrel as shown in Figure 17. The plug shall be dropped from a height of approximately 500 mm onto a plywood base with a nominal thickness of 9 mm. The plywood base shall have an impact face of birch of a nominal thickness of 1.4 mm and be of 5 ply construction. The barrel shall be turned at a rate of approximately 5 r.p.m. so that 10 falls per minute take place.

Only one plug shall be tested at a time. Each plug shall be dropped for the following number of times:

- a) for rewirable plugs: 1 000 times;
- b) for non-rewirable plugs: 2 500 times;
- c) for rewirable and non-rewirable rough-use plugs: 5 000 times.

21.3.4 Single and twin portable socket-outlets shall be fitted with 2-core or 3-core PVC sheathed flexible cords, appropriate to the design and current rating of the accessory, as given in BS 6500:2000+A3, Table 27. Terminal and cover screws shall be tightened with the torque given in Table 3. Non-rewirable single and twin portable socket-outlets shall be tested as delivered. The length of the flexible cord, measured from the nearest edge of the socket-outlet and with precoiled flexible cords extended before measurement, shall be 150 mm \pm 5 mm.

Single and twin portable socket-outlets shall be tested in the tumbling barrel as shown in Figure 17. The socket-outlet shall be dropped from a height of approximately 500 mm onto a plywood base with a nominal thickness of 9 mm. The plywood base shall have an impact face of birch of a nominal thickness of 1.4 mm and be of 5 ply construction. The barrel shall be turned at a rate of approximately 5 r.p.m. so that 10 falls per minute take place.

Only one socket-outlet shall be tested at a time. Each socket-outlet shall be dropped 5 000 times.

21.3.5 Portable socket-outlets having more than two outlets, and accessories that have mass or dimensions making them unsuitable for testing in the tumbling barrel, shall be fitted with a 2-core or 3-core PVC sheathed flexible cord appropriate to the design and current rating of the accessory, as specified in BS 6500:2000+A3, Table 27. Terminal and cover screws shall be tightened with the torque given in Table 3. The length of the flexible cord, measured from the nearest edge of the accessory and with precoiled flexible cords extended before measurement, shall be approximately 2 250 mm.

Non-rewirable portable socket-outlets and accessories shall be tested with the flexible cord as delivered, but cut to a length of approximately 2 250 mm.

The free end of the flexible cord shall be fixed to a wall at a height of 400_{-10}^0 mm above the floor, as shown in Figure 16.

The accessory shall be held so that the flexible cord is approximately horizontal. It shall then be allowed to fall on to a concrete floor eight times. The flexible cord shall be rotated through approximately 45° at its fixing each time.

21.3.6 Adaptors shall be tested in the tumbling barrel shown in Figure 17. The adaptor shall be dropped from a height of approximately 500 mm onto a plywood base with a nominal thickness of 9 mm. The plywood base shall have an impact face of birch of a nominal thickness of 1.4 mm and be of 5 ply construction. The barrel shall be turned at a rate of approximately 5 r.p.m. so that 10 falls per minute take place.

Only one adaptor shall be tested at a time. Each adaptor shall be dropped 25 times.

Adaptors shall also be tested in accordance with **21.2.1** using the apparatus shown in Figure 13, Figure 14 and Figure 15.

The adaptor shall be inserted into a flush socket-outlet. The flush socket-outlet shall be mounted on the apparatus in accordance with **21.3.2** so that the point of impact lies in the vertical plane through the axis of the pivot of the pendulum. Ten blows shall be applied to points evenly distributed over the adaptor. If the adaptor has a lens, the lens shall receive one blow of the striking element at a point approximately in its centre.

21.3.7 Other portable accessories which are intended to be remain connected to the supply when not in use shall be tested in the tumbling barrel as shown in Figure 17. These accessories shall be dropped from a height of approximately 500 mm onto a plywood base with a nominal thickness of 9 mm. The plywood base shall have an impact face of birch of a nominal thickness of 1.4 mm and be of 5 ply construction. The barrel shall be turned at a rate of approximately 5 r.p.m. so that 10 falls per minute take place.

Only one accessory shall be tested at a time. Each accessory shall be dropped 300 times.

If the accessory is intended to be used with a flexible cord, it shall be fitted with a 2-core or 3-core PVC sheathed flexible cord, as specified in BS 6500:2000+A3, Table 27 and as appropriate to the design and

current rating of the accessory. Terminal and cover screws shall be tightened with the torque given in Table 3.

Non-rewirable portable accessories shall be tested as delivered.

The length of the flexible cord, measured from the nearest edge of the accessory and with precoiled flexible cords extended before measurement, shall be 150 mm \pm 5 mm.

21.3.8 Screwed glands shall be fitted with a cylindrical metal rod having a diameter, in millimetres, equal to the nearest whole number less than the internal diameter, in millimetres, of the packing.

The glands shall then be tightened by means of a suitable spanner, the torque shown in Table 8 being applied to the spanner for 60₋₅⁰ s.

Table 8 Torque for mechanical test on glands

Diameter of test rod	Torque	
	Metal glands	Glands of moulded material
mm	N·m	N·m
Up to and including 14	6.25	3.75
Above 14 up to and including 20	7.5	5.0
Above 20	10.0	7.5

After the test, the glands and the boxes of the samples shall show no damage.

21.4 Assessment

21.4.1 When the accessories are tested in accordance with **21.3**:

- they shall show no damage which might affect safety;
- live parts shall not have become accessible; and
- no part of the accessories shall have become detached.

NOTE 1 Small chips or dents which do not affect the protection against electric shock are ignored.

NOTE 2 Cracks not visible to the naked eye, using normal or corrected vision without additional magnification, and surface cracks in fibre-reinforced mouldings are ignored.

21.4.2 When examined in accordance with **21.4.1**, accessories which pass shall be submitted to repeat tests in accordance with Clauses **19** and **20**, but with the following modifications and without disturbing the terminals or terminations.

- The length of cords specified in **21.3.3** and **21.3.4** shall be increased by 1000 mm \pm 50 mm, by the attachment of flexible cord of the same type and cross-sectional area, the connection being made by means of a connector having a current rating appropriate to that of the flexible cord.
- The length of cords specified in **21.3.5** shall be reduced to 1000 mm \pm 50 mm.

22 Resistance to heat

NOTE A diagrammatic summary of the tests described in this clause and Clause 23 is presented in Annex A.

22.1 With the exception of parts made from rubber and ceramics in fixed accessories, conformity shall be checked by the tests of **22.2**, **22.3**, **22.4** and **22.5**, as appropriate. When tested in accordance with **22.2**, **22.3**, **22.4** and **22.5**, the accessories shall be resistant to heat.

22.2 The samples shall be kept for 60^{+5}_0 min in a heating cabinet at the following temperature:

- a) $70\text{ °C} \pm 5\text{ °C}$ for portable accessories, mounting boxes, separate covers and separate cover plates; or
- b) $100\text{ °C} \pm 5\text{ °C}$ for all other accessories.

The samples shall be allowed to cool down to approximately room temperature. The samples shall then be tested by applying test probe 11 of BS EN 61032:1998 with a force not exceeding $5_{-0.5}^0$ N. When tested in this way, there shall be no access to live parts which are normally not accessible when the samples are mounted as in normal use.

After the test, the accessories shall not have undergone any change impairing further use. If the accessory includes a sealing compound, it shall not have flowed to such an extent that live parts are exposed.

NOTE Discoloration, blisters or slight displacement of the sealing compound is disregarded provided that safety is not impaired.

After the test, markings shall still be legible.

22.3 For fixed accessories:

- a) parts of insulating material necessary to retain current-carrying parts, and parts of the earthing circuit in position; and
- b) the material forming the front surface of fixed socket-outlets in a zone of 2 mm width around the live and neutral pin entry holes,

shall be subjected to a ball-pressure test in accordance with BS EN 60695-10-2:2003, except that the insulating parts necessary to retain the earthing terminals in a box shall be tested in accordance with **22.4**.

The test shall be made in a heating cabinet at a temperature of $125\text{ °C} \pm 5\text{ °C}$.

After the test the diameter of the impression caused by the ball shall be measured and shall not exceed 2 mm.

22.4 The following:

- a) parts of the insulating material not necessary to retain current-carrying parts and parts of the earthing circuit in position even though they are in contact with them; and
- b) portable accessories,

shall be subjected to a ball pressure test in accordance with **22.3**, but the test shall be made at whichever of the following temperatures is higher:

- 1) a temperature of $75\text{ °C} \pm 5\text{ °C}$; or
- 2) a temperature $T + (40\text{ °C} \pm 5\text{ °C})$ where T is the highest temperature rise determined for the relevant part during the test of Clause 20.

22.5 Portable accessories having external parts of resilient material (e.g. thermoplastics or rubber) shall be subjected to a pressure test by means of an apparatus similar to that shown in Figure 19. The test shall be performed in a heating cabinet at a temperature of $75\text{ °C} \pm 5\text{ °C}$.

The accessory shall be clamped between the jaws in such a way that the jaws press against it in the area where the accessory is gripped in normal use, the centreline of the jaws coinciding as nearly as possible with the centre of this area.

The force applied through, including the effect of, the jaws shall be 20_{-1}^0 N .

After 60_{0}^{+5} min the jaws shall be removed and the accessory shall show no damage.

Figure 18 *Figure deleted*

Figure 19 Apparatus for pressure test on portable accessories

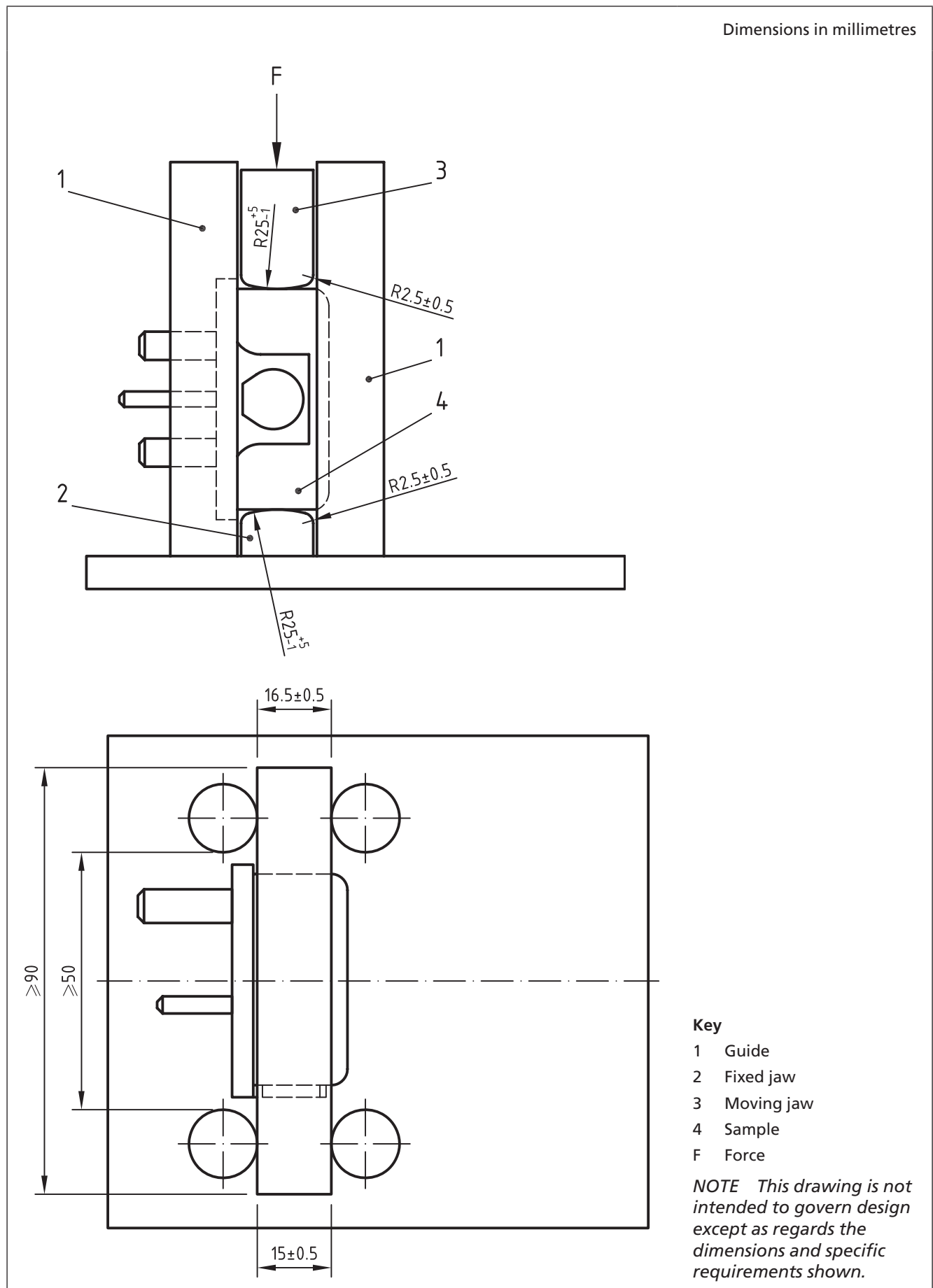

23 Resistance of insulating material to abnormal heat, and to fire

NOTE A diagrammatic summary of the tests described in this clause and Clause 22 is presented in Annex A.

23.1 General

Parts of insulating material which might be exposed to thermal stresses due to electric effects and the deterioration of which might impair the safety of the accessory, shall not be unduly affected by abnormal heat and by fire.

When tested in accordance with 23.2 the accessory shall satisfy one of the following criteria.

- a) There shall be no visible flame and no sustained glowing.
- b) Flames and glowing shall extinguish within 30 s after the removal of the glow-wire. There shall be no ignition of the wrapping tissue or scorching of the board.

23.2 Glow-wire test

The test shall be performed in accordance with BS EN 60695-2-11:2001, Clauses 5 to 11, under the following conditions:

- a) for parts of insulating material necessary to retain current-carrying parts in position, by the test made at a temperature of:
 - 1) 850 °C ± 15 °C for fixed accessories;
 - 2) 750 °C ± 10 °C for portable accessories.
- b) for parts of insulating material not necessary to retain current-carrying parts in position, although they may be in contact with them, by the test made at a temperature of 650 °C ± 10 °C.

If it is necessary to perform the tests at more than one place on the same accessory, care shall be taken to ensure that any deterioration caused by previous tests does not affect the result of subsequent tests.

The test shall not be performed on the following:

- i) small parts, e.g. washers; and
- ii) parts made of ceramic material.

NOTE 1 The glow-wire test is applied to ensure that neither of the following can occur:

- a) an electrically heated test wire under defined test conditions does not cause ignition of insulating parts; nor
- b) a part of insulating material, which might be ignited by the heated test wire under defined conditions, has a limited time to burn without spreading fire either by flame or by burning droplets from the tested part falling onto the pinewood board covered with a tissue paper.

NOTE 2 If possible, the specimen should be a complete accessory.

NOTE 3 If the test cannot be made on a complete accessory, a suitable part may be cut from it for the purpose of the test. The test is made on one specimen. In case of doubt, it is essential that the test is repeated on two further specimens.

The test shall be made by applying the glow-wire once.

The specimen shall be positioned during the test in the most unfavourable position for its intended use (with the surface tested in

a vertical position). The tip of the glow-wire shall be applied to the specified surface of the specimen taking into account the conditions of the intended use under which a heated or glowing element may come into contact with the accessory.

24 *Clause deleted*

25 Resistance to excessive residual stresses and to rusting

WARNING. Refer to the supplier's health and safety data sheets for the precautions which are to be taken for the safe use of mercurous nitrate, nitric acid, ammonium chloride, alkalis and organic solvents.

25.1 Current-carrying parts of copper alloy containing less than 80% of copper, which are press-formed or produced in a similar manner which could induce excessive internal stresses, shall be resistant to failure in use due to brittleness.

When tested in accordance with the following method, there shall be no cracks visible with normal or corrected vision without additional magnification.

The sample shall be degreased in an alkaline degreasing solution or organic solvent, then immersed in an aqueous solution of mercurous nitrate containing 10 g of $\text{Hg}_2(\text{NO}_3)_2$ and 10 mL of HNO_3 (relative density 1.42) per litre of solution for 30 min \pm 1 min at a temperature of 20 °C \pm 5 °C.

After the treatment the sample shall be washed in running water, any excess mercury wiped off, and the sample shall be visually examined immediately.

25.2 Ferrous parts, including covers and boxes, shall be adequately protected against rusting.

When tested in accordance with the following method, there shall be no signs of rust.

The sample shall be degreased in a suitable alkaline degreasing solution or organic solvent.

The parts shall then be immersed for 10 min \pm 0.5 min in a 10% (m/m) solution of ammonium chloride in water at a temperature of 20 °C \pm 5 °C.

On removal of the parts from the solution, excess shall be shaken off without drying. The parts shall then be placed for 10 min \pm 0.5 min in a box containing air saturated with moisture at a temperature of 20 °C \pm 5 °C.

The parts shall be dried for 10 min \pm 0.5 min in a heating cabinet at a temperature of 100 °C \pm 5 °C.

NOTE 1 Traces of rust on sharp edges and any yellowish film removable by rubbing are ignored.

NOTE 2 For small springs and the like, and for inaccessible parts exposed to abrasion, a layer of grease may provide sufficient protection against rusting. Such parts are subjected to the test only if there is doubt about the effectiveness of the grease film and the test is then made without previous removal of the grease.

Annex A (informative) Summary of tests on insulating parts of accessories

The tests to be performed on the insulating parts of accessories are represented diagrammatically in Figure A.1.

Figure A.1 Diagrammatic representation of the sequence of tests on insulating parts of accessories

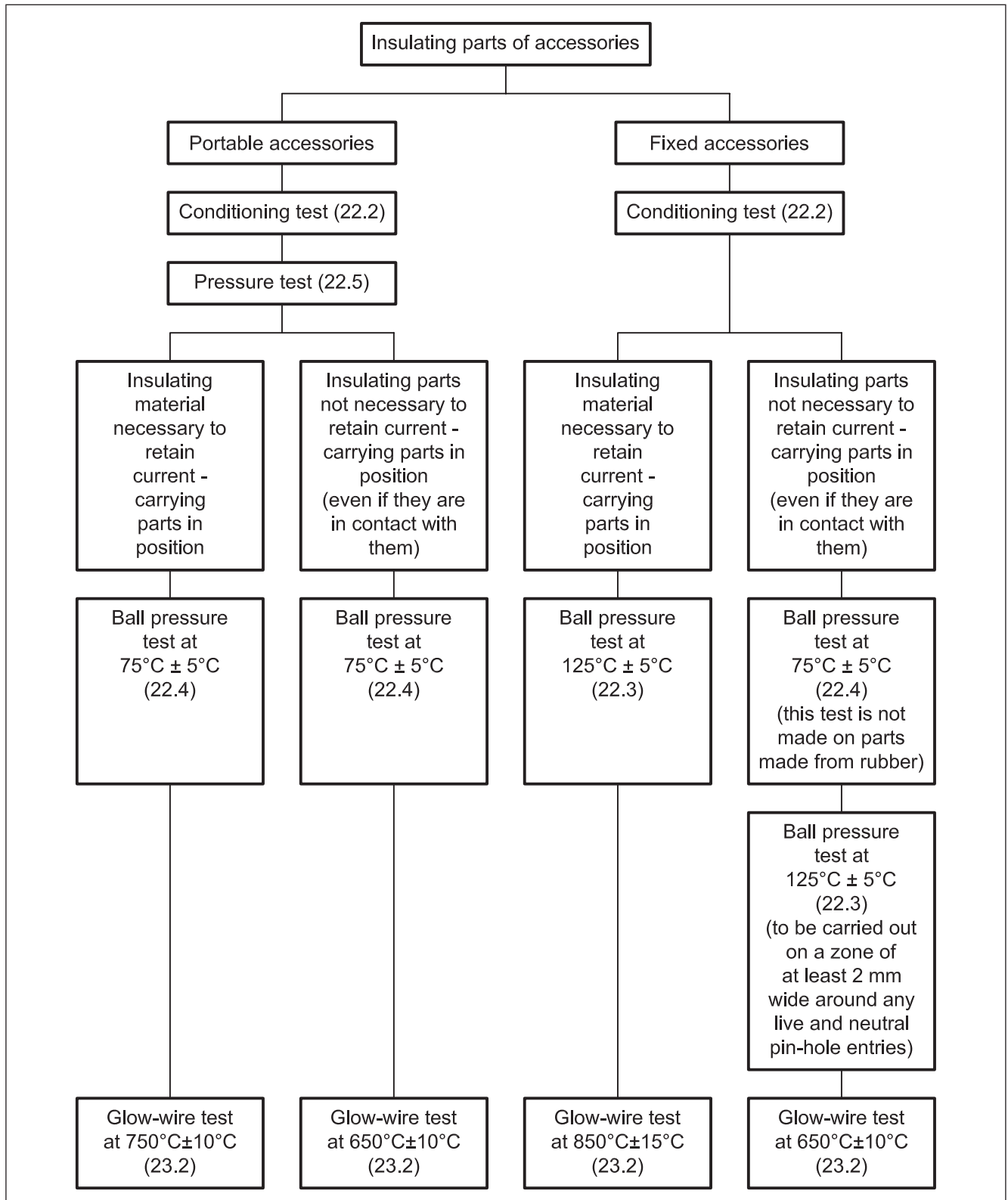

Annex B (normative) Measurement of clearances and creepage distances

Measurement of clearances and creepage distances shall be carried out in accordance with Examples 1 to 11, as applicable.

The value of width "X" specified in Examples 1 to 11 shall be a function of the pollution degree as given in Table B.1.

Table B.1 Minimum values of width "X"

Pollution degree (see Annex E)	Minimum values of width "X" mm
1	0.25
2	1.0
3	1.5

NOTE 1 If the associated clearance is less than 3 mm, the minimum groove width may be reduced to one third of this clearance.

NOTE 2 The examples do not differentiate between gaps and grooves or between types of insulation.

The following rules shall be applied.

- Any recess shall be assumed to be bridged with an insulating link having a length equal to the specified width "X" and being placed in the most unfavourable position (see Example 3);
- Where the distance across a groove is equal to or larger than the specified width "X", the creepage distance shall be measured along the contours of the groove (see Example 2);
- Creepage distances and clearances measured between parts which can assume different positions in relation to each other, shall be measured when these parts are in their most unfavourable position.

Key to Examples 1 to 11

----- Clearance

===== Creepage distance

All dimensions are in millimetres

EXAMPLE 1

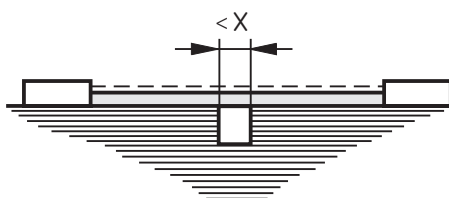

Condition: Path under consideration includes a parallel- or converging-sided groove of any depth with a width less than "X" mm.

Rule: Creepage distance and clearance shall be measured directly across the groove as shown.

EXAMPLE 2

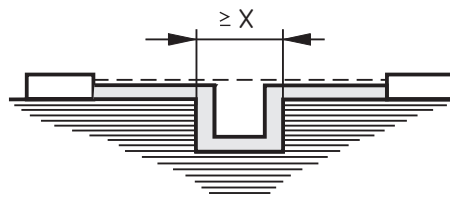

Condition: Path under consideration includes a parallel-sided groove of any depth and with a width equal to or more than "X" mm.

Rule: Clearance shall be the "line of sight" distance. Creepage path shall follow the contour of the groove.

EXAMPLE 3

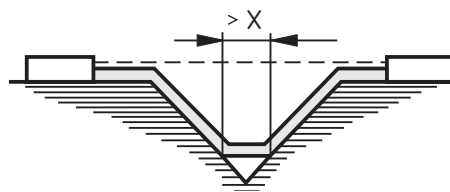

Condition: Path under consideration includes a V-shaped groove with a width greater than "X" mm.

Rule: Clearance shall be the "line of sight" distance. Creepage path shall follow the contour of the groove but "short circuit" the bottom of the groove by an "X" mm link.

EXAMPLE 4

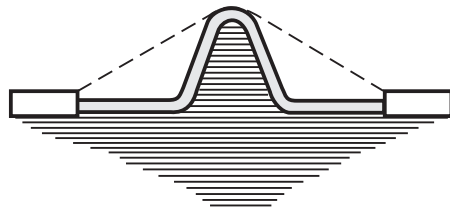

Condition: Path under consideration includes a rib.

Rule: Clearance shall be the shortest direct air path over the top of the rib. Creepage path shall follow the contour of the rib.

EXAMPLE 5

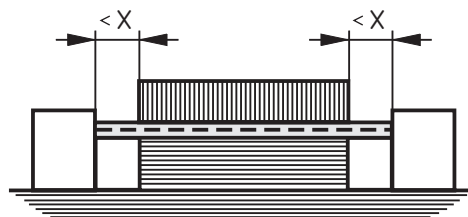

Condition: Path under consideration includes an uncemented joint with grooves less than "X" mm wide on each side.

Rule: Creepage and clearance path shall be the "line of sight" distance shown.

EXAMPLE 6

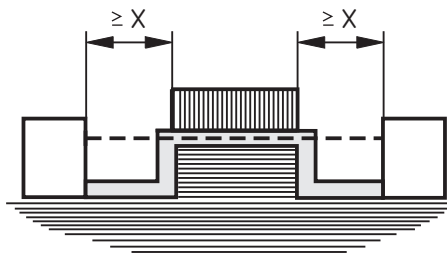

Condition: Path under consideration includes an uncemented joint with grooves equal to or more than "X" mm wide on each side.

Rule: The clearance path shall be the "line of sight" distance. Creepage shall follow the contour of the grooves.

EXAMPLE 7

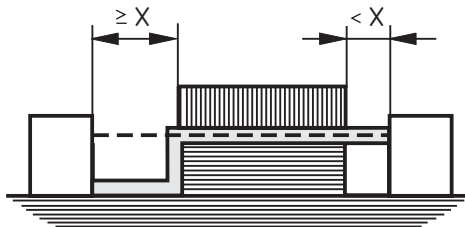

Condition: Path under consideration includes an uncemented joint with the groove on one side less than "X" mm wide and the groove on the other side equal to or more than "X" mm wide.

Rule: Clearance and creepage paths shall be as shown.

EXAMPLE 8

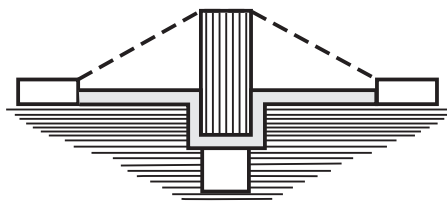

Condition: Path under consideration includes a barrier with an uncemented joint. The creepage distance through the uncemented joint is less than the creepage distance over the barrier.

Rule: Clearance shall be the shortest direct air path over the top of the barrier. The creepage path shall follow the contour of the joint.

EXAMPLE 9

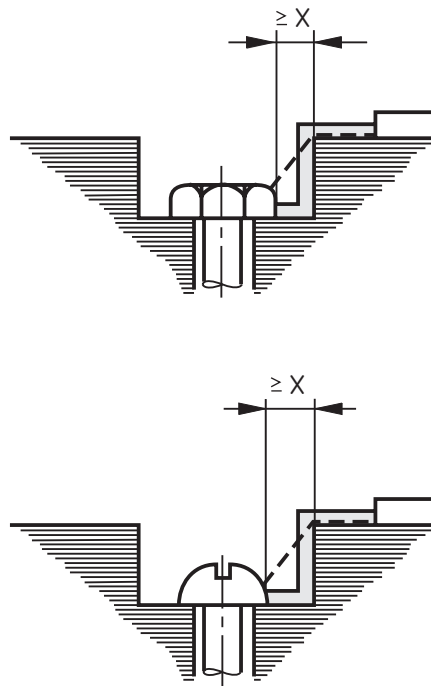

Condition: Gap between head of screw and wall of recess wide enough to be taken into account (greater than or equal to "X" mm).

Rule: Clearance and creepage distance paths shall be as shown.

EXAMPLE 10

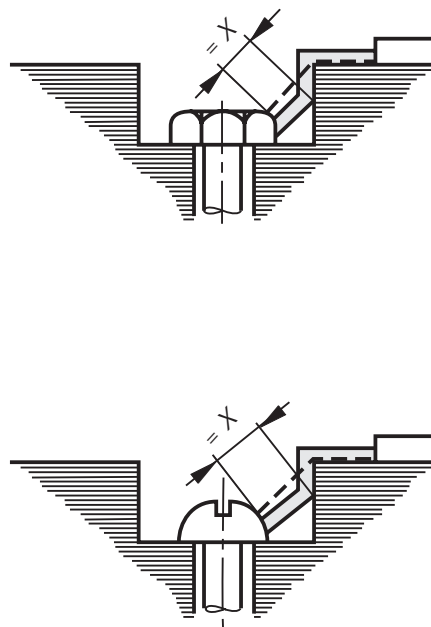

Condition: Gap between head of screw and wall of recess too narrow to be taken into account (less than "X" mm).

Rule: Measurement of clearance and creepage distance shall be from the screw head to the point on the wall which is at a distance equal to "X" mm (as shown).

Licensed copy: Lee Shau Kee Library, HKUST, Version correct as of 03/01/2015, (c) The British Standards Institution 2013 Licensed copy: Lee Shau Kee Library, HKUST, Version correct as of 03/01/2015, (c) The British Standards Institution 2014

EXAMPLE 11

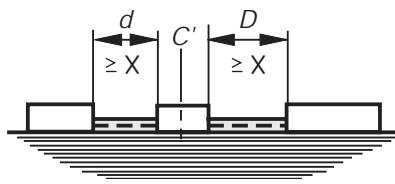

Condition: Path under consideration includes a floating part, C' , with different sized grooves on either side, each greater than or equal to "X" mm.

Rule: Clearance and creepage distance shall be both be distance $d + D$.

Annex C (normative)

Determination of the comparative tracking index (CTI) and proof tracking index (PTI)

The CTI or PTI shall be determined in accordance with BS EN 60112, with the following provisions.

- a) In BS EN 60112:2003+A1, Clause 5 Test specimen:
 - Note 3 and the last paragraph also apply to PTI.
 - If the surface 15 mm × 15 mm cannot be obtained because of the small dimensions of the PT system then special samples made with the same manufacturing process may be used.
- b) The test solution "A" described in BS EN 60112:2003+A1, 7.3 shall be used.
- c) In BS EN 60112:2003, Clause 8, Procedure, either CTI or PTI is determined.
 - CTI shall be determined in accordance with BS EN 60112:2003+A1, Clause 11.
 - The PTI test of BS EN 60112:2003, Clause 10, shall be performed on five samples at the voltage referred to in BS EN 60112:2003+A1, 10.1 based on the appropriate creepage distance, material group, pollution degree and on the rated voltage of this standard as declared by the manufacturer.

Annex D (normative) Relation between rated impulse withstand voltage, rated voltage and overvoltage category

The relation between rated impulse withstand voltage, rated voltage and overvoltage category shall be as given in Table D.1.

Table D.1 Rated impulse withstand voltage for accessories energized directly from the low voltage mains

Nominal voltage of the supply system based on IEC 60038 ^{A)} V	Voltage line-to-neutral derived from nominal voltages a.c. or d.c. V	Rated impulse withstand voltage V		
		Overvoltage Category		
		I	II	III
230/400	Up to and including 300	1 500	2 500	4 000

NOTE 1 For more information concerning supply systems see BS EN 60664-1.

NOTE 2 For more information concerning Overvoltage Category see BS EN 60664-1.

NOTE 3 Accessories fall into Overvoltage Category III. Parts of accessories where appropriate overvoltage reduction is provided fall into Overvoltage Category I. Energy consuming equipment falls into Overvoltage Category II.

^{A)} The / mark indicates a four-wire three-phase distribution system. The lower value is the voltage line-to-neutral, while the higher value is the voltage line-to-line.

Annex E (normative) Pollution degree

COMMENTARY ON ANNEX E

The micro-environment determines the effect of pollution on the insulation. The macro-environment, however, has to be taken into account when considering the micro-environment.

Means may be provided to reduce pollution at the insulation under consideration by effective use of enclosures, encapsulation or hermetic sealing. Such means to reduce pollution might not be effective when the PT system is subject to condensation or if, in normal operation, it generates pollutants itself.

Small clearances can be bridged completely by solid particles, dust and water and therefore minimum clearances are specified where pollution might be present in the micro-environment.

NOTE Pollution will become conductive in the presence of humidity. Pollution caused by contaminated water, soot, metal or carbon dust is inherently conductive.

For the purpose of evaluating creepage distances and clearances, one of the following three degrees of pollution in the micro-environment shall be used, as declared by the manufacturer.

- Pollution degree 1
No pollution or only dry, non-conductive pollution occurs. The pollution has no influence.

- Pollution degree 2
Only non-conductive pollution occurs except that occasionally a temporary conductivity caused by condensation is to be expected.
- Pollution degree 3
Conductive pollution occurs or dry non-conductive pollution occurs which becomes conductive due to condensation, which is to be expected.

Annex F (normative) Impulse withstand voltage test

F.1 General

The purpose of this test is to verify that solid insulation, and clearances not verified by measurement, will withstand specified transient overvoltage. The impulse withstand voltage test is carried out with a voltage having a 1.2/50 μ S waveform as specified in BS 923-1 and is intended to simulate overvoltage of atmospheric origin. It also covers overvoltages due to switching of low-voltage equipment.

F.2 Procedure

The test shall be conducted for a minimum of three impulses of each polarity with an interval of at least 1 s between impulses. There shall be no discharges during the test. Glow discharges without drop in voltage shall be ignored.

For solid insulation and for clearances not verified by measurement, the impulse withstand voltage shall be applied between:

- a) line and neutral terminals/terminations;
- b) line and neutral terminals/terminations connected together and:
 - 1) a metal foil in contact with the entire accessible external surface;
 - 2) the earthing terminal/terminations;
 - 3) any metal part of a cord anchorage;
- c) each switched pole terminal of a switched accessory with the switch contacts open.

NOTE 1 The output impedance of the impulse generator should be not higher than 500 Ω .

NOTE 2 The expression "discharge" is used to cover the phenomena associated with the failure of insulation under electric stress, which includes current flow and a drop in voltage.

The impulse shall have the waveform 1.2/50 μ S for the no load voltage with amplitudes equal to the values given in Table F.1.

NOTE 3 If the sample is provided with surge suppression the impulse voltage wave may be chopped but the sample should be in a condition to operate normally again after the test. If the sample is not provided with surge suppression and it withstands the impulse voltage, the waveform will not be noticeably distorted.

Table F.1 Test voltages for impulse withstand test

Rated impulse withstand voltage \hat{U}	Impulse test voltage at sea level \hat{U}
kV	kV
0.33	0.35
0.5	0.55
0.8	0.91
1.5	1.75
2.5	2.95
4.0	4.8
6.0	7.3

NOTE 1 When testing clearances, associated solid insulation will be subjected to the test voltage. As the impulse test voltage of Table F.1 is increased with respect to the rated impulse withstand voltage, solid insulation will have to be designed accordingly. This results in an increased impulse withstand capability of the solid insulation.

NOTE 2 The test may be made with the pressure adjusted to the value corresponding to the altitude of 2000 m (80 kPa) and 20 °C with the test voltage corresponding to the rated impulse withstand voltage. In this case, solid insulation will not be subjected to the same withstand voltage as when testing at sea level.

NOTE 3 Explanations concerning the influencing factors (air pressure, altitude, temperature, humidity) with respect to electric strength of clearances are given in BS EN 60664-1.

Bibliography

Standards publications

For dated references, only the edition cited applies. For undated references, the latest edition of the referenced document (including any amendments) applies.

BS 923-1, *Guide on high-voltage testing techniques – Part 1: General*

BS EN 60664-1:2007, *Insulation coordination for equipment within low voltage systems – Part 1: Principles, requirements and tests*

BS EN 61140, *Protection against electric shock – Common aspects for installation and equipment*

IEC 60038, *IEC Standard voltages*

IEC 60417-DB, *Graphical symbols for use on equipment*

British Standards Institution (BSI)

BSI is the national body responsible for preparing British Standards and other standards-related publications, information and services.

BSI is incorporated by Royal Charter. British Standards and other standardization products are published by BSI Standards Limited.

About us

We bring together business, industry, government, consumers, innovators and others to shape their combined experience and expertise into standards-based solutions.

The knowledge embodied in our standards has been carefully assembled in a dependable format and refined through our open consultation process. Organizations of all sizes and across all sectors choose standards to help them achieve their goals.

Information on standards

We can provide you with the knowledge that your organization needs to succeed. Find out more about British Standards by visiting our website at bsigroup.com/standards or contacting our Customer Services team or Knowledge Centre.

Buying standards

You can buy and download PDF versions of BSI publications, including British and adopted European and international standards, through our website at bsigroup.com/shop, where hard copies can also be purchased.

If you need international and foreign standards from other Standards Development Organizations, hard copies can be ordered from our Customer Services team.

Subscriptions

Our range of subscription services are designed to make using standards easier for you. For further information on our subscription products go to bsigroup.com/subscriptions.

With **British Standards Online (BSOL)** you'll have instant access to over 55,000 British and adopted European and international standards from your desktop. It's available 24/7 and is refreshed daily so you'll always be up to date.

You can keep in touch with standards developments and receive substantial discounts on the purchase price of standards, both in single copy and subscription format, by becoming a **BSI Subscribing Member**.

PLUS is an updating service exclusive to BSI Subscribing Members. You will automatically receive the latest hard copy of your standards when they're revised or replaced.

To find out more about becoming a BSI Subscribing Member and the benefits of membership, please visit bsigroup.com/shop.

With a **Multi-User Network Licence (MUNL)** you are able to host standards publications on your intranet. Licences can cover as few or as many users as you wish. With updates supplied as soon as they're available, you can be sure your documentation is current. For further information, email bsmusales@bsigroup.com.

BSI Group Headquarters

389 Chiswick High Road London W4 4AL UK



Revisions

Our British Standards and other publications are updated by amendment or revision.

We continually improve the quality of our products and services to benefit your business. If you find an inaccuracy or ambiguity within a British Standard or other BSI publication please inform the Knowledge Centre.

Copyright

All the data, software and documentation set out in all British Standards and other BSI publications are the property of and copyrighted by BSI, or some person or entity that owns copyright in the information used (such as the international standardization bodies) and has formally licensed such information to BSI for commercial publication and use. Except as permitted under the Copyright, Designs and Patents Act 1988 no extract may be reproduced, stored in a retrieval system or transmitted in any form or by any means – electronic, photocopying, recording or otherwise – without prior written permission from BSI. Details and advice can be obtained from the Copyright & Licensing Department.

Useful Contacts:

Customer Services

Tel: +44 845 086 9001

Email (orders): orders@bsigroup.com

Email (enquiries): cservices@bsigroup.com

Subscriptions

Tel: +44 845 086 9001

Email: subscriptions@bsigroup.com

Knowledge Centre

Tel: +44 20 8996 7004

Email: knowledgecentre@bsigroup.com

Copyright & Licensing

Tel: +44 20 8996 7070

Email: copyright@bsigroup.com

...making excellence a habit.™