



Code of practice for

Safety in erecting structural frames

UDC 624.072.33:624.05:614.8 – 027

NO COPYING WITHOUT BSI PERMISSION EXCEPT AS PERMITTED BY COPYRIGHT LAW



Committees responsible for this British Standard

The preparation of this British Standard was entrusted by the Civil Engineering and Building Structures Standards Committee (CSB/-) to Technical Committee CSB/42, upon which the following bodies were represented:

British Constructional Steelwork Association Ltd.
 British Precast Concrete Federation Ltd.
 Building Employers' Confederation
 Chartered Institute of Building
 Concrete Society
 Construction Health and Safety Group
 Federation of Civil Engineering Contractors
 Health and Safety Executive
 Incorporated Association of Architects and Surveyors
 Institute of Clerks of Works of Great Britain Inc.
 Institution of Civil Engineers
 Institution of Occupational Safety and Health
 Institution of Structural Engineers
 Precast Flooring Federation
 Royal Institute of British Architects
 Timber Research and Development Association
 Trades Union Congress

This British Standard, having been prepared under the direction of the Civil Engineering and Building Structures Standards Committee, was published under the authority of the Board of BSI and comes into effect on 31 August 1988

© BSI 02-1999

First published January 1978
 First revision August 1988

The following BSI references relate to the work on this standard:
 Committee reference CSB/42
 Draft for comment 86/15420 DC

ISBN 0 580 16547 7

Amendments issued since publication

Amd. No.	Date of issue	Comments

Contents

	Page
Committees responsible	Inside front cover
Foreword	iii
<hr/>	
Section 1. General	
1 Scope	1
2 Definitions	1
3 Legislation (general)	1
<hr/>	
Section 2. Primary safety considerations	
4 Competence	2
5 Training	2
6 Responsibility	2
7 Supervision	2
8 Design	2
<hr/>	
Section 3. Considerations affecting all erection tasks	
9 Erection methods, design stage	3
10 Planning for erection	3
11 Drawings and instructions	3
12 Coordination of operations	4
13 Site preparation	4
14 Setting-out, levelling and alignment	4
15 Bearings allowing movement	5
16 Connections	5
17 Holding down arrangements	5
18 Use of cranes and other lifting devices	6
19 Slinging of loads	7
20 Care and use of lifting tackle	10
21 Use of jacks	10
22 Working arrangements	10
23 Safety belts, harnesses and nets	11
24 Weather	11
25 Welding and cutting	11
26 Radiography	12
27 Bolting, drilling and reaming	12
28 Painting	13
29 Work in artificial light	13
30 Delivery, handling and movement on site	13
31 Availability of parts and materials	14
32 Erection of railings and balustrades	14
33 Pre-glazed framework units	14
<hr/>	
Section 4. Erection of frames	
34 Stability at all stages	15
35 Precast concrete frameworks	24
36 Bonding	28
37 Steel frameworks	28
38 Space frameworks	31
39 Timber frameworks	33
40 Aluminium frameworks	34
41 Plastics frameworks	34

	Page
Figure 1 — Use of typical remote release shackle	8
Figure 2 — Spreader beam and lifting bar arrangement	9
Figure 3 — Levelling packs under base plates	19
Figure 4 — Stability of single columns (diagrammatic representation)	20
Figure 5 — Stability of single bays: braced (diagrammatic representation)	20
Figure 6 — Stability of single bays: unbraced	21
Figure 7 — Stability of rigid boxes	22
Figure 8 — Stability of single slender beam or truss	23
Figure 9 — Stability of pair of slender beams or trusses	23
Figure 10 — Stability of roof trusses	24
Figure 11 — Stability of rigid structural panel	24
Figure 12 — Precast concrete portal frame: typical arrangement of props to support rafter members	26
Figure 13 — Precast concrete column: typical bracing arrangement	27
Figure 14 — Lifting of trusses	30
<hr/>	
Table 1 — Alternative types of support for structural elements during erection	16
Table 2 — Types of support for providing stability and their applications	17
<hr/>	
Publications referred to	Inside back cover
<hr/>	

Foreword

This revision of BS 5531 has been prepared under the direction of the Civil Engineering and Building Structures Standards Committee, and supersedes BS 5531:1978, which is withdrawn.

This code was originally written in 1978 against a background of concern about the number of accidents and collapses occurring during the erection of structural frames. A recurring feature in those accidents was poor practice. It was therefore considered that presenting good practices in code form would beneficially affect the future accident situation and would result in increased efficiency in the construction industry. It was considered that there were certain features of good erection practice which were common to all types of frames. This information is contained in section 3 of the code. A study of that section is a prerequisite to a proper application of the rest of the code.

Examples shown in the text are representative of acceptable practice but organizations may use their own tried techniques.

In this revision the text has been extensively altered in detail to conform with present legislation and guidance.

In addition to legislation relevant to the subject of this code and listed in section 1, clause 3, attention is also drawn to the Health and Safety Executive Guidance Notes GS 28/1-4, "Safe erection of structures".

Attention is also drawn to BS 6100 "Glossary of building and civil engineering terms".

A British Standard does not purport to include all the necessary provisions of a contract. Users of British Standards are responsible for their correct application.

Compliance with a British Standard does not of itself confer immunity from legal obligations.

Summary of pages

This document comprises a front cover, an inside front cover, pages i to iv, pages 1 to 36, an inside back cover and a back cover.

This standard has been updated (see copyright date) and may have had amendments incorporated. This will be indicated in the amendment table on the inside front cover.

Section 1. General

1 Scope

This code of practice makes recommendations concerning safety in erecting the principal types of structural frames, mainly in precast concrete and steel. Consideration is also given to the following:

- a) space frameworks
- b) timber frameworks
- c) aluminium frameworks
- d) plastics frameworks

This code does not include recommendations on work involved in the erection of in situ concrete frames (see BS 5975).

This code does not deal with those aspects of site safety which are generally applicable to all construction operations and for which guidance and information are readily available elsewhere (e.g. use of hand tools, ladders, etc.).

NOTE The titles of the publications referred to in this standard are listed on the inside back cover.

2 Definitions

For the purposes of this code the following definition applies.

method statement

a document setting out a safe system of work, in detail dependent on the complexity of the work involved

NOTE Other terms used in this code are those in common use during construction operations.

3 Legislation (general)

The following list gives the principal legislation, current at the date of publication of this code, affecting safety in erection work or relating to operations associated with it.

Health and Safety at Work etc. Act, 1974

Factories Act, 1961

Statutory Instrument 1961 no. 1580
Construction (General provisions)
Regulations, 1961

Statutory Instrument 1961, no. 1581
Construction (Lifting Operations)
Regulations, 1961

Statutory Instrument 1966, no. 94 Construction
(Working Places) Regulations, 1966

NOTE When applying this code, users are advised to ascertain the current state of legislation.

Section 2. Primary safety considerations

4 Competence

In this code it is assumed that all those engaged in all aspects of the work are competent for the task. Care should be taken to ensure that persons are only called upon to carry out tasks which may reasonably be expected from persons of their levels of competence.

The term competent person is not a defined term and has been the subject of legal discussion. However, as a guide, a person may be regarded as able to perform the duty if he has sufficient practical and theoretical knowledge and actual experience of the work in question to enable him to recognize hazards associated with the work being undertaken.

5 Training

Contractors should be able to show that training in safe working practice has been given to site supervisory staff and other employees and that they are competent in their designated jobs.

Training needs should be identified as early as possible and this can sometimes be assisted by an examination of incidents and accident records.

The training of foreman, supervisor and site manager levels will need to extend to an understanding of the implications of method statements, the significance of legal requirements, project planning, the establishment and running of the site organization and the provision of project induction training to operatives.

6 Responsibility

This code can best be applied as part of a comprehensive approach to safety from planning to execution when clearly defined areas of responsibility have been laid down and communicated to all those engaged in the work.

Responsibilities for planning safe erection can, and should, start at the initial design stage. Designers should take into account the need for, and the practicability of, safe methods of working during erection.

The structural analysis and design should identify those features of the structure which have a critical influence on its overall and continuing stability and structural integrity during construction. The fabricating and/or erecting contractor would retain the responsibility for choosing or accepting a particular method of fabrication and erection.

7 Supervision

Supervision should be considered as an overriding requirement.

Supervisors should be given instructions on the work they are to oversee. Supervisors should pay particular attention to whether the relevant drawings, documents and methods of erection procedure have been issued and whether, in their experience, they are adequate to allow a safe method of working to be established.

Supervisors should be competent to recognize and deal with a potentially dangerous situation.

8 Design

The general term design/designer refers to all stages from concept through to structural design and detailing. This may include design for both permanent and temporary works and involve one or more designers.

Section 3. Considerations affecting all erection tasks

9 Erection methods, design stage

9.1 General

Guidance on the design, erection and use of the materials used for structural frames can be obtained from the following:

- CP 118 Aluminium
- BS 5268 Timber
- BS 5950 Steel
- BS 8110 Concrete
- BS 5975 Falsework

9.2 Lifting and handling of framework elements

The component parts or pre-assembled portions of a structure should be designed in such a way that they can be handled, transported, lifted and positioned safely. Attachment points for slings and eyebolts should be marked when lifting at other positions could cause harm to the structure (e.g. distortion or weakening) or instability.

9.3 Interconnection of members and elements

Members and elements should be so designed that they cannot be interconnected incorrectly during assembly or erection.

9.4 Lack of stability and weakness

The designer should consider the risks due to lack of stability and weakness which may occur during erection and take appropriate action.

9.5 Erection

The structure on which erection work is being performed will have been designed for the acceptance of normal design loading. In course of erection temporary loads may be applied due to deposited material, loads incidental to the erection procedure or the effect of wind on partially completed frameworks. It is essential that the erection procedure takes due account of these loadings at the design stage.

10 Planning for erection

10.1 General

It is important that there should be a coordinated plan for all matters affecting erection. In particular, account should be taken of any limitations that may exist at the site in means of access, storage and the size or weight of components. Careful consideration should be given to planning the sequence of erection. As much of the structure as is practicable should be pre-assembled at ground level.

10.2 Temporary attachment

Special attention should be given to the need for temporary attachments and lifting connections (e.g. working platforms, etc.). Such attachments require the same design considerations as those for permanent use. Whenever possible these attachments should be fitted at the fabrication stage.

11 Drawings and instructions

11.1 Drawings

Copies of all relevant working drawings and instructions should be kept on site so that they are easily available and accessible to all concerned. The use of transparent waterproof covers for the protection of drawings on site should be considered.

An additional complete master set should be kept in the site office for reference purposes only.

The erection scheme drawings should show specifically how stability, and in particular, lateral stability, is to be achieved at each successive step in erection.

11.2 Instructions

11.2.1 General. The communication of safe erection procedures is vitally important, particularly to those who actually fix the components in place. It is recommended that the details of these procedures should be clearly shown on drawings or fully described in written instructions or instruction manuals. Any unusual or key features should be clearly emphasized, for example.

- a) Both these diagonal bracing members have to be present and fully secured in position before any erection work on an adjacent frame or upper frame is commenced

or

- b) The stability of the roof steelwork depends on the presence of the brickwork at the gable ends. The steelwork should not be erected until 7 days after the brickwork has been completed or until such a time as it has developed sufficient strength, and a strong and rigid connection to it can be made.

11.2.2 The erection scheme. The instructions should include information about all measures that need to be adopted and provisions made to allow the work to take place to a predetermined programme. The following items, not so far mentioned, might form part of a typical scheme.

- a) The sequence and methods to be adopted for the supply and storage of components and materials.
- b) Equipment and tools to be used and their capacity.

- c) The type and positioning of lifting equipment, including methods of dealing with the handling, lifting and fixing of large or heavy components. Such methods should ensure the components are not over-stressed during lifting.
- d) The use of temporary bracings, props, guys or other measures to ensure stability at each (successive) stage.
- e) The provision of access and working platforms.
- f) Methods for dealing with particularly hazardous operations (e.g. work in close proximity to the general public; work over roads, railways and water; the use of radiography; proximity of overhead power lines, etc.).

11.2.3 Deviation from the erection scheme. Should circumstances arise on site that require a deviation from the erection scheme (see **11.2.2**), the supervisor has to satisfy himself that such a deviation will have no detrimental effect upon the stability or safety of the structure being erected.

In any case of doubt he should seek advice about and obtain approval for such changes. If these changes affect the integrity of the structure, reference should also be made to the designer before any changes are made.

12 Coordination of operations

12.1 General

Erection should be arranged in such a way that work in one place does not create an additional hazard either in the same place or in another.

12.2 Work occurring simultaneously at different levels

Where erection work is taking place immediately above areas where other work is in progress, measures should be taken to protect those working below.

12.3 Work occurring simultaneously at or near the same place

Hazards may arise (e.g. with subcontractors) where men undertaking different tasks are working close to each other. Special care is necessary in supervision to ensure that those engaged on one task do not introduce a hazard by interfering with or modifying the work of those engaged on another. Serious consequences can arise where a component is moved out of its intended position to make room for another without information or permission being given.

13 Site preparation

13.1 General

The contractor should check the site for hazards before starting work, and should note any special features. There should be suitable unobstructed safe access for delivery vehicles, cranes and other plant. The position of overhead services, particularly live electric cables, should be checked, as should the positions of any buried services which may be vulnerable to damage by traffic. Movement about the site should be planned with the provision of sound access ways. This may require the formation of temporary roads and hard standings designed for the loads involved. Separate clean and clear pedestrian access ways may be necessary.

The increasing use of access equipment requires the provision of a higher standard of site preparation. The control of other site activities, such as trench excavation, may be necessary so that the use of access equipment is not hindered.

13.2 Storage area

Sufficient area should be allocated for the stacking, storage and handling of materials and components. This area should be clean, even, firm and reasonably level and of adequate size, clear of any of the hazards mentioned in **13.1**.

Stacking should be such that no overloading either of the storage area or of the individual units occurs. Bearers will need to be used between units and the height of the stack should be limited as far as possible. The need to climb on to the stack should be avoided.

If frames are used for storage, it is essential that they are stable and that they are loaded and unloaded so as to minimize eccentric loading.

13.3 Above ground storage

Components may need to be stored on the framework. Positions, layout and loading have to be determined before the commencement of work and loads should be placed without impact.

14 Setting-out, levelling and alignment

14.1 Precautions in setting-out

The required degrees of accuracy should be clearly determined before setting-out is begun. The limiting tolerances should be stipulated if they have not already been included in the specification. Failure to achieve these tolerances may result in dangerous improvisations.

14.2 Levelling and alignment

Levelling and alignment is a potentially dangerous stage in the erection sequence, when temporary instability may occur.

Before levelling and alignment is performed on a framework fastenings should not be slackened or withdrawn until the stability of the framework in this condition has been checked by a competent person and it has been declared safe to proceed. As far as possible all permanent bracing members should be in position before any attempt is made to adjust level or alignment. Where continued stability may be in doubt temporary bracing members or guy lines should be introduced and made secure in such a way that their effectiveness is not impaired by adjustments to the framework.

In a multi-bay framework, a preferred method is to complete levelling and alignment to within two bays of the erection front, in the case of heavy steelwork, and to within four bays, in the case of light steelwork. It is not recommended that the whole framework of the building is erected before levelling and alignment.

15 Bearings allowing movement

Although the main use of rotational sliding bearings is on bridges, they may be used on other types of structures. They usually have a relatively slender key to prevent movement and under erection conditions this may be insufficient to ensure stability. Temporary supporting frames may therefore be necessary until sufficient beams have been erected and tied together.

16 Connections

16.1 General

All connections should have sufficient space around each fastener to allow use of the spanner, socket or, at weld positions, to allow access of the electrode etc. They should be arranged to minimize the time working at height by both operatives and supervision staff.

See also clauses 25 and 27.

16.2 Column splices

Where joints occur in the length of the columns they should be located to take advantage of the access and working platforms that can be provided by incoming floor beams. Sufficient fixings should be provided to ensure the stability of the upper section of the column until it is adequately tied in to the rest of the structural framework.

16.3 Beam splices

Where joints are made in beams to achieve continuity over their length, unless specific provision has been made in the design, each part of the beam should be temporarily supported until the connection has been completed. Working platforms from which the connection is made may also be incorporated.

17 Holding down arrangements

17.1 Design aspects

Anchorage should be designed to ensure that they have adequate strength and can be installed in the manner intended and function properly. Construction difficulties should be anticipated so that holding down bolts are secured or fastened in the desired position during placing of foundation concrete. Provision should also be made for alignment and levelling.

The designer should specify what time interval should elapse or what strength should be achieved before fixing is made to an anchorage and load applied.

Where holding down is dependent on the presence of counterweights, the erection sequence should be carefully designed so that equilibrium can be maintained at all stages.

The use of a length of a flat, angle or channel which accepts two or more bolts is recommended to anchor the bolts. This distributes the load over a greater area of concrete and aids accurate positioning of the bolts.

Attention is drawn to the following common causes of anchorage failure which indicate the need for care in design and during construction.

- a) Plate washers of insufficient thickness or diameter under the heads of holding down bolts. (The washer should be large enough and strong enough to bridge the adjustment sleeve when one is used. A thickness of at least one half the holding down bolt diameter is likely to be required.) Washers under the nuts of holding down bolts should also be of adequate dimensions.
- b) Insufficient curing of epoxide resin materials.
- c) Holding down bolts or fittings difficult to fix or located in positions where they coincide with reinforcement or other items. This may lead to displacement of bolts or reinforcement.
- d) Insufficient length of holding down bolts, insufficient projection or wrong position leading to their omission or weakened fastenings.

17.2 Erection precautions

17.2.1 It is often the case that the design requirements for the holding down arrangements in the finished structure are nominal and that their value is largely related to positioning. However, it is possible that far larger stresses may be applied during erection. The erection scheme should demonstrate that all stresses likely to be introduced in the holding down arrangements during erection are acceptable.

17.2.2 The strength of concrete, brickwork, grout, etc. on which an anchorage depends for its effectiveness should be allowed to develop to a sufficient extent before any fastening is made or load applied.

17.2.3 It is desirable that pockets or adjustment space surrounding holding down bolts should be kept dry in winter and not allowed to become full of water which may subsequently freeze. (The expansion effect on freezing may fracture the concrete and weaken the anchorage.)

17.2.4 The effect of wind should be taken into account in all stages of erection. It is necessary to ensure that the anchorage and fastenings are adequate to accept wind load and that components, materials and all parts of the permanent construction liable to be subject to uplift or disturbance are properly held down.

17.2.5 Where the erection procedure adopted is likely to bring about uplift in any portion of the framework, the holding down arrangements in that portion should be complete, effective and adequate before the work starts. The adequacy of the holding down arrangement should be checked by calculation and its presence verified by inspection.

18 Use of cranes and other lifting devices

18.1 General

Efficient use of lifting equipment depends on sequential and correct stacking of material and adequate access thereto. Areas of hardstanding should be firm, level and suitably maintained to permit their use.

The principal characteristics of various forms of crane, the more common hazards and potential dangers in use and the precautions to be taken are described in CP 3010.

The recommendations contained in that code should be followed. In addition the following recommendations pertinent to the erection of structural frames should be observed.

18.2 Use of cranes in artificial light

If cranes are to be used for the erection of frames in artificial light, reference should be made to **29.4**.

18.3 Multiple lifts

Tandem lifting is dealt with in **1.11.5** of CP 3010:1972. Multiple lifting, although not recommended in CP 3010, may exceptionally be necessary where it has been impossible to eliminate it from the planning, assembly and erection scheme. Such lifting is only permissible provided that it is carefully planned by competent design staff and subject to a high degree of supervision and control. One person should be nominated to be in charge of the operation, and crane drivers should obey his instructions only.

Among the points to be considered are the following.

- a) Where a load is to be moved by two or more mobile or crawler track cranes, the path required to be followed by each crane should be very clearly marked. It is of the greatest importance that there should be coordinated movement and no deviation from the planned route. All persons involved in movements of this kind should be given special instruction and before it commences should be fully conversant with the task and the nature and extent of their own duties.
- b) Each crane's share of the load can only be approximated and in making an assessment of this load a considerable safety factor should be allowed. In deciding the crane capacity, allowance should be made for possible oscillation of the load, dynamic effects and variations in ground level which may cause one crane to be relieved of the load and additional burden placed on the others.

18.4 Work in the vicinity of suspended loads

Loads which are suspended close to a framework and particularly when near working positions should be manoeuvred with considerable care.

Loads in course of movement should always be under complete control and it is preferable for the load to be moved too slowly rather than too quickly. Rotation and swinging of the load in course of lifting should be anticipated and clearances should always be adequate to prevent the load from fouling the structure and erection equipment. Guide ropes should be used when necessary to keep the load under complete control.

The support provided by a crane should never be removed until the component being fixed is adequately secured.

18.5 Jammed parts

18.5.1 When parts which are being placed in position with the use of a crane or lifting gear become jammed, and require to be freed, it is essential that a safe procedure be adopted.

18.5.2 Danger may arise in several ways such as:

- a) overloading of the crane or hoisting equipment, e.g. through attempts to pull a vertically suspended load sideways or failure of the slings or lifting attachments;
- b) overloading of parts of the structure or the whole of the structure;
- c) sudden release, causing risk of injury to men who may be struck or caused to fall by the swinging load;
- d) damage to the jammed part which may lead to an accident or further misfit of parts.

18.5.3 A safe procedure for freeing jammed parts should be decided by inspection and dimension checks to ascertain:

- a) whether the jammed part is the correct part;
- b) whether the jammed part is of the correct size;
- c) whether the framework dimensions are correct for the acceptance of the part.

18.5.4 The method of freeing adopted should be decided by a competent person. It should avoid the hazards outlined in **18.5.2** and may involve one or more of the following measures:

- a) provision of suitable restraint during freeing operations;
- b) loosening of adjacent framework connections;
- c) judicious use of jacks, crowbars and pulling devices;
- d) careful burning without causing harm to existing assembled portions of the framework and persons involved.

19 Slinging of loads

19.1 General

Precautions should be taken in the slinging and handling of loads in accordance with the recommendations given in CP 3010. For a specification for chain lever hoists refer to BS 4898.

19.2 Lifting and slinging

19.2.1 When lifting:

- a) the total weight to be lifted should be established and should include lifting gear such as slings, lifting beams, crane blocks and rope falls as appropriate;
- b) the use of special devices such as tilting shoes for columns and lifting frames for sub-assemblies should be considered;
- c) all lifting frames and beams should be designed, tested (when applicable) and should display prominently the safe working load and the self weight.

19.2.2 When slinging, it is particularly important that use is made of:

- a) a remote release system to obviate the need for access to release slings at height (see Figure 1 and Figure 2);
- b) lifting aids such as lifting beams to prevent overloading the slings and to provide support for slender flexible assemblies such as roof trusses;
- c) two-leg slings, wherever possible, as they provide greater stability of the load, although care should be taken to ensure that the included angle is within the safe range;
- d) packing to help avoid damaging the slings and prevent the load slipping.

19.2.3 Other factors to be considered include:

- a) preventing unwanted rotational movement of loads, particularly long loads, by using hand lines fixed near the ends of each load;
- b) avoiding shock loading on slings by lifting and lowering slowly at all times;
- c) using timber battens on which to land loads so that the sling can be removed easily and is not damaged by crushing.

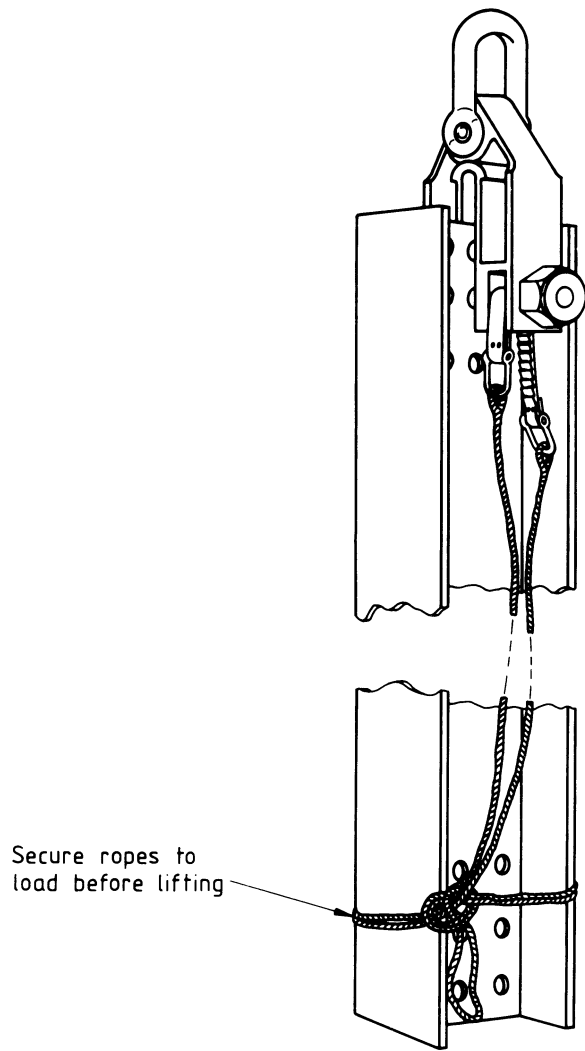

NOTE 1 After lifting the material the shackle is released by pulling the release ropes first one way and then the other five or six times. The ratchet action withdraws the pin allowing the shackle to be lifted clear of the column.

NOTE 2 This figure is reproduced by courtesy of Dawson Construction Plant Limited.

Figure 1 — Use of typical remote release shackle

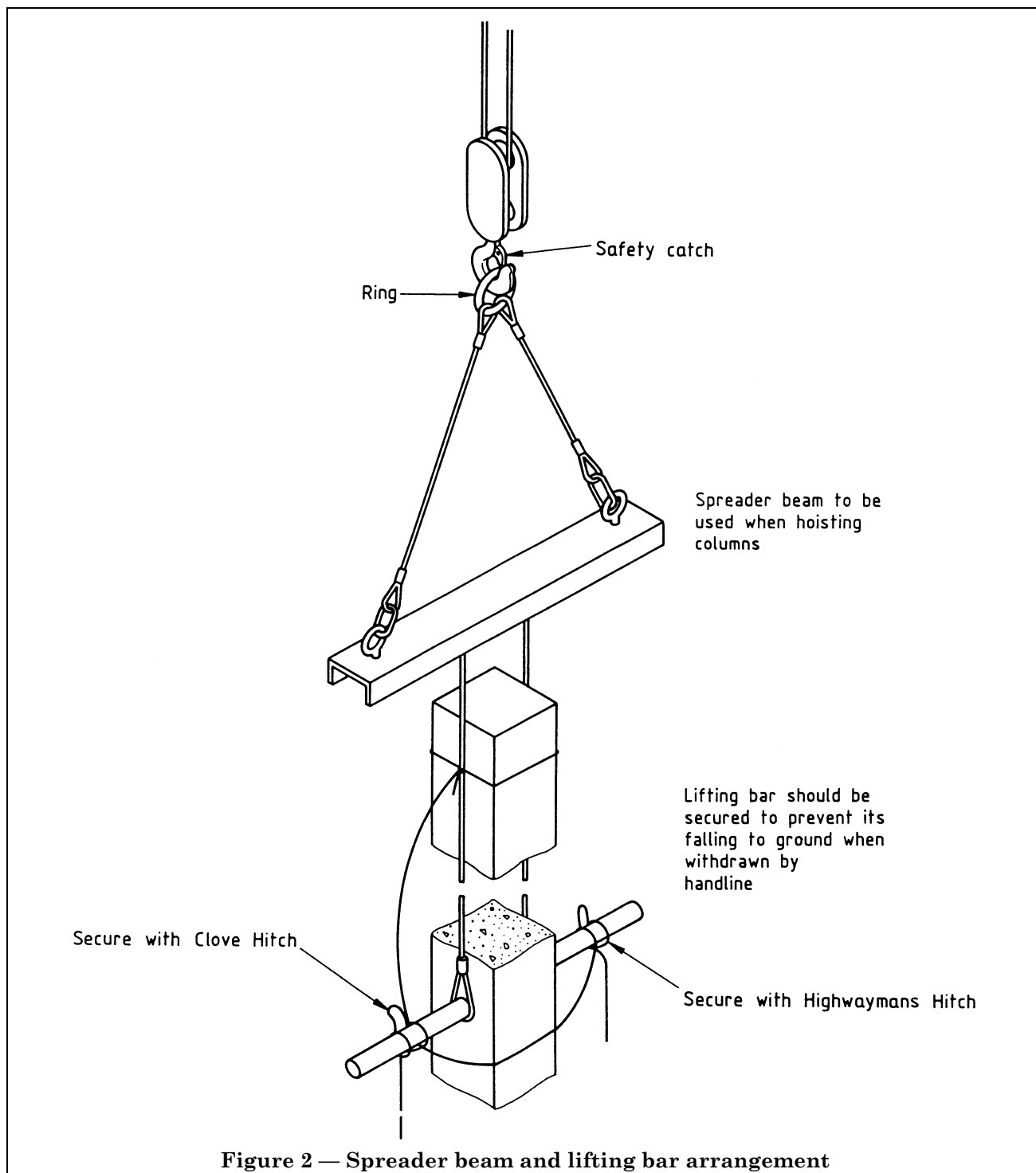

Figure 2 — Spreader beam and lifting bar arrangement

19.3 Trial lift

Since structural frames are often of large irregular shape, sometimes with the centre of gravity outside the compass of the frame, the centre of gravity should be indicated on the drawing and the balance of the load checked by a trial lift.

19.4 Release of lifting gear

Safe access should be provided, e.g. lightweight ladders unless remote release shackles are used.

20 Care and use of lifting tackle

WARNING. It is essential that lifting appliances and lifting gear are mechanically sound and free from defects and properly maintained. Inspections and examinations are essential and the results should be recorded as follows.

- a) Examination of lifting gear — weekly when in use
- b) Thorough examination of lifting gear — every 14 months
- c) Test and thorough examination of lifting appliances — every 4 years
- d) Test and inspection of lifting gear — every 6 months

20.1 No item of lifting equipment should be used for a purpose other than its normal lifting function. Particular care should be taken that slings and chains are not misused or overstressed.

20.2 Slings should always be carefully stored away from extremes of heat, cold and wet and in positions where they are not liable to be damaged.

20.3 The use of racks for chain slings is recommended.

20.4 No work should be carried out with the appliances and gear unless the documentation described in the warning note above is up to date.

21 Use of jacks

21.1 Jacks should be positioned and operated with care so that they do not slip while being used or cause instability, reduction of strength or local damage. They should always be of adequate capacity. Jacks used for erection work should have a base area sufficiently large to prevent accidental overturning. Hydraulic jacks may with advantage incorporate a load-sustaining screw collar as a safeguard in the event of pressure failure. Ratchet type jacks should not be fitted with a trip mechanism causing instantaneous release of the load; movement in both directions should be possible only by means of ratchet action.

21.2 Loads should not be maintained in the raised position by the use of jacks alone and a robust packing of hardwood blocks or steel joists should be positioned under the load and follow it up so as to provide support in the event of jack failure.

21.3 When two or more traversing jacks are being used, considerable resistance to traversing may be experienced. This may be the result of the traversing of the jacks not being absolutely synchronized, thus causing the arrangement to act like a large scale lock-nut device. Visually the phenomenon is not immediately obvious; neither is the direction in which further traversing (to or fro) will release the “lock”.

21.4 In multi-jacking systems care should be taken to coordinate the jacking so that no single jack becomes overloaded. Otherwise damage may result to the jack in question, or the member it is jacking against.

22 Working arrangements

22.1 A prerequisite of safe working arrangements is to minimize the time when men have to work at a height. This can be done by pre-assembling as much of the structure as possible at ground level. Work on open structures should be kept to an absolute minimum, since most serious accidents to erectors result from falls. Working platforms, gangways, ladders, etc. should be provided whenever practicable.

22.2 Vertical access should normally be by ladders, or, preferably, staircases, temporary or permanent. Provision should be made for the ascent or descent of ladders to start from a landing place which should be provided with an edge protection if there is a risk of falling. Ladder access should be provided by pre-locating the ladders on a frame member prior to lifting. Attachments may be by cleats or clamps so designed that the ladder can be lifted clear after the erector has descended.

22.3 In appropriate cases a man-carrying skip suspended from a crane may be used for vertical access. The Construction (Lifting Operations) Regulations 1961, Regulations 44 and 47 are particularly relevant on these occasions.

22.4 Horizontal access on open frameworks should be provided by gangways constructed at ground level and lifted into position. Fixing details should be simple and aimed at minimizing the number of work operations performed at a height. A working platform should if possible be pre-located on the appropriate frame member prior to erection. Fixings should be as few as possible and should be easily removable at a height.

22.5 Mobile scaffolds, hydraulic access equipment and static scaffold towers can be used when ground conditions are suitable. The early provision of the floor will promote the use of such equipment.

23 Safety belts, harnesses and nets

23.1 General

Guidance on the construction, use and testing of safety belts and safety nets can be found in the following:

- BS 1397 Industrial safety belts and harnesses
- BS 3913 Industrial safety nets
- BS 5062-2 Self locking anchorages
- CP 93 The use of safety nets on constructional works

23.2 Anchorages for safety lines and lanyards

The aim is to provide anchorage either for making connections in a static situation or by the means of fixed lines where these are appropriate.

Attachments should be made by the use of equipment which will not open inadvertently. If lanyards are looped around a member it is advised that a minimum 16 mm diameter lanyard is used or, alternatively, a 12 mm diameter lanyard with a sleeve.

Anchorages for velocity sensing arrestor devices or for the line used with inertia sensing arrestor devices should be considered at a stage when they can be incorporated in detailed drawings and a method of work planned which does not subject the user to risk due to having to fix or retrieve the device.

24 Weather

Erection work should not take place in weather conditions which introduce an undue element of risk. These conditions include:

- a) high wind;
- b) heavy rain;
- c) presence of frost or ice;
- d) heavy snow;
- e) poor visibility.

When conditions deteriorate to an extent when safe working is endangered, any further work should be restricted to that necessary to ensure stability of the structure.

An erection operation which is already in progress and where suspension of work would introduce a hazard should whenever possible be completed.

25 Welding and cutting

25.1 Welding

25.1.1 *Fit-up, access and position.* Careful consideration should be given to the fit-up of the parts to be welded, with regard to tolerances and any lack of alignment. Satisfactory access should be provided for welders. All welds should be readily accessible for both the welding and inspection.

25.1.2 *Welding of temporary attachments.* Welding of temporary attachments to permanent steelwork may have a deleterious effect on the strength of tension members if incorrect procedures are used. All procedures for temporary welds and their subsequent removal should be subject to prior approval (see 11.2). This also applies to the welding of heavy lifting lugs, where the risks of lamellar tearing in the permanent material should be assessed.

25.1.3 *Erection procedures.* Where welding procedures are required they should be prepared in accordance with BS 4870 and carried out in accordance with BS 5135 or such other British Standards relevant to the material of the structure. The requirements for stiffness and stability should be taken into account during the various stages of erection and appropriate temporary supports should be used where necessary.

25.1.4 *Staging and shelter.* Suitable staging and shelter should be provided for the welder. Suitable screening should be provided for the protection of others from the dangers of "arc eye" and welding splatter. The screening should also prevent accidental contact with the hot metal.

25.1.5 *Ventilation.* Adequate ventilation is necessary where welding is being carried out. If natural ventilation is not sufficient (e.g. inside box sections), artificial ventilation should be provided.

NOTE See also HSE Guidance Note GS 5 available from HMSO.

Where metals are coated (e.g. with lead, zinc, cadmium or red lead paint) and are to be welded, precautions should be taken to ensure the resultant fumes are not inhaled. Where necessary, fume extractors should be used, or breathing apparatus in extreme cases. Red lead paint adjacent to welds should be removed before welding to minimize the generation of dangerous fumes. In choosing a suitable solvent it should be remembered this might also involve a fume or flammability hazard and appropriate precautions should be taken.

25.1.6 Pre-welding site preparation. The following preparations should be made before welding takes place.

- a) All mobile welding equipment should be firmly secured in position before welding commences.
- b) All flammable material should be moved from the vicinity of the welding arc taking into account the spread of spatter and sparks in all directions, particularly below the welder. Special attention should be paid to oil, gas, wood shavings, foamed plastics materials and the risk of igniting coatings of paint or plastics, etc. Where flammable materials cannot be moved it is essential that there should be adequate protection between the materials and the welding arc. Where flammable material is present below the place of welding a fire resisting sheet should be suspended to prevent all sparks and spatter from falling below.
- c) Where some significant fire risk remains, the welder should have a welding sentry who has fire fighting equipment appropriate to the type and size of fire risk. All fire fighting equipment should be checked regularly to see that it is charged and serviceable.

25.1.7 Electrical safety. Electrical safety is a complex subject requiring special consideration. For further guidance see BS 638.

25.2 Cutting

The severing of parts (e.g. temporary supports by cutting) may impart a severe shock to the structure that in certain situations could lead to instability. Cutting of all structural members should therefore be supervised by personnel who have investigated and checked the implications of the cutting on structural safety. The cutting of metals coated with lead, zinc or cadmium should be carried out with particular care see 25.1.5). The vulnerability of personnel carrying out cutting on structural frameworks to possible injury should be assessed and every effort should be made to minimize any foreseeable risks.

25.3 Handling of cylinders

Gas cylinders should be handled with care to avoid risk of mechanical damage to the cylinder and the regulator and fittings.

All valves should be closed before cylinders are moved, unless a properly designed carrier or trolley is available to support the cylinder and its attachments.

Lifting of cylinders by chains and slings can be hazardous. It is preferable for cylinders to be moved on site in a special carrier or trolley. Cylinders in use on stagings and platforms should not be left unattended; when not in use they should be secured. Acetylene cylinders should be stored and used in an upright position.

26 Radiography

If radiographic work is undertaken, it should preferably be carried out when other work is not in progress. Attention is drawn to the Ionizing Radiations Regulations 1985 and the accompanying Approved Code of Practice and "Radiation safety for site radiography" published by Kluwer Harrap on behalf of the Oil and Chemical Plant Contractors Association.

27 Bolting, drilling and reaming

27.1 Working position and use of hand tools

27.1.1 When hand tools are used, appropriate safe working procedures should always be adopted so that in the event of the tool slipping or kicking suddenly the tool and the person holding it will not fall.

27.1.2 Spanners and wrenches should always be of the proper size and applied in the correct way. Power operated tools should be kept in good condition.

27.2 Alignment

27.2.1 Holes should be properly aligned before assembly and bolts should not be forced into holes.

27.2.2 In course of final assembly any temporary bolts or clamps used to assist in obtaining alignment should be replaced progressively by the permanent fastenings. Sufficient temporary fastenings should always be present to restrain parts.

27.3 Torqued and high strength bolts

Torqued and high strength bolts should be assembled in accordance with the manufacturer's recommendations. They should not be over-tightened or re-used. Guidance is given in BS 3294 and BS 4604.

27.4 Safe keeping of loose bolts and nuts

All loose bolts, nuts and other parts including tools should be placed in positions from which they cannot be dislodged. Suitable containers should be used when possible.

27.5 Drilling and reaming

In addition to the normal precautions when drilling and reaming, the following require special attention.

- a) Small or light parts should be clamped for drilling and should not be held by hand or retained underfoot.
- b) Excessive drilling pressure should be avoided. Chips or swarf should be removed with a brush and never by hand. Safety goggles should be worn if broken drills are to be removed with cutting or punching tools.
- c) When drilling or reaming into a member the operator should make sure that there is no one on the other side.

28 Painting

Hand-over procedures should be established to ensure that each section is structurally complete before painting is commenced. Safe access and working platforms should be provided for painters.

Working and walking on painted steelwork is not permitted until the paint is dry and hard.

29 Work in artificial light

29.1 Wherever possible all framework erection should be done in daylight but where work has to be performed in artificial light the basic recommendations of **29.2** to **29.6** should be met.

29.2 The level of illumination at the place of work and its access routes should be sufficient for the tasks to be undertaken.

29.3 Wall and floor apertures, hoist positions, guy wires and obstructions should be clearly lighted or defined with warning lights.

29.4 Cranes used for unloading or erection should have floodlights installed on their jibs which illuminate the following for the whole of the time that the work is in progress:

- a) the load;
- b) an area around the load sufficient to guard against collision with obstructions while the load is in transit.

29.5 Static lighting should be provided at the load lifting point and the depositing point or fixing point.

29.6 As far as possible lights should be arranged so that persons do not have to pass from illuminated areas to dark areas in the course of performing their erection tasks. Zones of contrasting light intensity, glare and dazzle should be avoided. Areas of shadow which are usually created by floodlights should be eliminated by the use of local lighting.

30 Delivery, handling and movement on site

30.1 General

Special care is necessary in delivery and handling of components on site where unloading facilities are often less satisfactory than when loading at the manufacturer's works. It is desirable that deliveries should be properly planned to coincide with the availability of personnel and plant adequate to deal with the work. Erratic arrival times should be avoided.

30.2 Access

Satisfactory means of access to the site should be provided and maintained so that delivery vehicles can reach the proper unloading point. Suitable unloading facilities should be available and the ground should be capable of withstanding the wheel loads of the delivery vehicles as well as any mobile plant used for unloading.

30.3 Marking of loads

Weights of all items should be readily available and lifting points/or sling positions marked where necessary.

30.4 Stacking

The height of stacked materials and components should be limited and supporting blocks and wedges used as necessary to ensure that there is no risk of sliding, collapse or distortion.

30.5 Movement on site

The sequence in which parts are loaded should be such that they can be removed in the desired order.

Drivers should not be present in the driving cab of the vehicle which is being loaded or unloaded. The driver of a vehicle being loaded should be able to verify the position of the load and the fastening arrangements.

It is desirable that each part loaded on a vehicle or trailer should be individually restrained. Accidents can occur while unloading if several parts are secured with the same fastening and the removal of one part causes disturbance or collapse of the others. The stability of one part should not depend on the presence of another. Where it is not possible to use individual fastenings, the danger of load movement after the fastening is released should be guarded against. The stability of the vehicle during off-loading should be maintained.

As far as possible, all framework elements which are likely to be of such shape or weight as to involve difficulty in handling should be transported in a position from which they can be directly lifted.

30.6 Movement of vehicles

When any vehicle is reversed a banksman should be in attendance.

Care should be taken that parked vehicles do not become obstructions.

31 Availability of parts and materials

Before starting any phase of the work, all necessary components and supporting equipment should be at hand.

32 Erection of railings and balustrades

Permanent access ways, staircases and handrailing should be erected concurrently with the main structure.

The use of railings and balustrades as temporary erection supports should not be permitted.

33 Pre-glazed framework units

The presence of glass in a pre-glazed unit (structural or otherwise) should be made evident to avoid the risk of breakage and injury.

Section 4. Erection of frames

34 Stability at all stages

34.1 An erection scheme should be produced which ensures the stability of the framework and its components at all stages. Adequate allowance should be made for wind loading on the framework. Allowance should also be made for the effect of wind on any temporary construction and equipment mounted on the framework, including frictional drag on any erected portions of flooring, roofing or cladding. Temporary supports such as bracing, guys or props should be specified and used where necessary. They should be incorporated as the work progresses and should remain in position until the structure is stable. Any deviation from the erection scheme should be approved by the scheme originator.

34.2 The basic principle should be to commence by erecting a bay or portion of the structure which is fully stabilized.

34.3 In the process of erection particular care should be taken to verify stability in the following circumstances:

- a) at times of temporary cessation of work;
- b) at times when fastening may be incomplete, e.g. in course of lining-up and adjustment of level;
- c) at times of high wind or when high winds are expected;
- d) at times of abnormal snow loading;
- e) when the state of completion of permanent work (e.g. brickwork, concrete, etc.) on which the stability depends is inadequate or when the permanent work has not developed adequate strength;
- f) when the structure or parts of it may be subject to construction loads (e.g. from impact, stacking of parts and lifting or freeing of components which may have become inadvertently wedged in position).

34.4 The requirement for stability at all stages of erection should be understood by all persons dealing with the erection work. Any procedure specified should be strictly followed. Where temporary supports are specified they should be of adequate design and construction and should only be used in the way intended. Improvised supports should not be used.

34.5 Props which are used for compression forces should be so constructed that they cannot be screwed apart. Push-pull props and props which are used for both tension and compression forces should function efficiently in both directions. Anchorages to both ends of the prop should be strong enough to withstand the loads applied. Bent or damaged props or those without hardened pins should not be used.

34.6 In some designs lateral stability may be provided by the cladding panels or floor construction and a framed structure may not be safe until they are fixed. Where panels affording stability are to be added after erection of the framework temporary supports have to be provided.

34.7 Where stability depends on brickwork or concrete elements, these should be present to perform their function as the erection of the framework proceeds. Otherwise, temporary bracings will have to be provided.

34.8 The construction of anchor points should be such that they are able to resist any force likely to be imposed on them. The movement of an anchor should be reported immediately and prompt remedial action taken.

The use of movable anchor points (e.g. railway trucks or farm tractors) should not be permitted in any circumstances.

Steel cables should not enter the ground unless suitably protected. The fastening of guy lines to anchorages in the ground should be carried out using chains or steel bars or sections. Screw type anchors should be used in accordance with the manufacturer's instructions.

The base of any mast or pole used for erection should be provided with an adequate bearing to ensure distribution of the load to the ground without settlement. Resistance to sideways movement of the base should be provided during erection.

34.9 Methods of supporting different structural members or assemblies, together with advice for ensuring stability during erection, are given in Table 1¹⁾.

34.10 Applications for different methods of providing stability are shown in Table 2¹⁾. The different methods shown can be applied in different combinations to individual members and sub-assemblies as well as to the erected or partially erected structure.

¹⁾ Table 1 and Table 2 and Figure 3 to Figure 11 are reproduced by courtesy of HMSO.

Table 1 — Alternative types of support for structural elements during erection

Structural element member or assembly	Alternative types of support (see Table 2 for advice on use)	Comments
Columns – single	Guying and propping (B) Embedded anchorages and column bases (D)	Temporary supports (Figure 4) should be provided unless the holding down system has been proved able to resist the overturning moment Where only two holding down bolts are used, the column should be propped or guyed. A minimum of four erection packs should be positioned to enhance stability (Figure 3)
Columns – pairs Single bays	Bracing (A) Guying and propping (B) Permanent connections (C) Embedded anchorages and column bases (D) Shear resisting elements and panels (E) Temporary structures (F)	To be made stiff as soon as possible, and before a second bay is erected (Figure 5, Figure 6 and Figure 7)
Structural panels	Bracing (A) Guying and propping (B) Permanent connections (C) Embedded anchorages and column bases (D) Shear resisting elements and panels (E) Temporary structures (F)	Temporary support will invariably be required (Figure 11)
Lattice girders Slender beams Roof trusses – single	Guying and propping (B) Temporary structures (F)	Lattice girders (Figure 8), slender beams and roof trusses have little lateral stiffness and resistance to both toppling and bending should be provided. Erection may be with the aid of strong backs or lifting beams. This lifting gear should not be removed until satisfactory stability has been achieved with suitable connections to the supporters
Lattice girders Slender beams Roof trusses – pairs and groups Sub-assemblies	Bracing (A) Guying and propping (B) Guying and propping (B) Permanent connections (C) Temporary structures (F)	Pairs of rafter beams require plan bracing (Figure 7(b) and Figure 9). Roof trusses may be erected in groups with a designed lifting beam; plan bracing usually required (Figure 10) It is often better to create as many sub-assemblies as possible so that there is inherent stability and connections made at height are reduced. Towers and masts could be include in this category. During assembly adequate support of individual pieces is required and care has to be taken to recognize and counter any possible imbalance when further pieces are connected. These supports should be stable and based on good foundations
NOTE The types of support listed in the middle column indicate the most appropriate alternatives.		

Table 2 — Types of support for providing stability and their applications (see notes 1 to 6)

Types of support	Possible applications	Requirements for effectiveness	Advantages	Disadvantages	Other considerations
A. Bracing (permanent and/or temporary) including both plan and vertical	Pair of columns Group of columns Stiff bay Rigid box Providing transverse support to pairs of horizontal or sloping members such as in roofs and floors	Rigidly fixed connections Accurately designed and manufactured/fabricated components	Contained within structure grid lines and less likely to be accidentally removed or hit Can form part of the permanent structure to obviate removal problems later	Permanent: induced construction loads may be greater than when completed and a check is required Temporary: removal of high level cleats and brackets may be required when bracing is no longer necessary	When possible, erection should start in bays where permanent bracing is provided. If not, temporary supports should be provided unless proved to be unnecessary High level brackets should be left in whenever possible
B. Guying and propping	Single column Pairs of columns Group of columns Stiff bay Rigid box Structural panel Slender beams and trusses (lateral support)	Suitable and adequate strength of fixing positions on components Secure fixing to component to prevent accidental displacement Adequate anchorage at base location to cater for tension and compression as required, and in all weathers Ability to vary and maintain force on component safely	Readily obtainable Commonly known method	Can obstruct access ways Subject to accidental impact damage May have special fixings to be removed at height when no longer required Sometimes difficult to make and sustain secure fixings	Some supports act only in tension (e.g. guys) or in compression (e.g. non push-pull props) Guys should be of suitable wire rope
C. Permanent connections (load bearing and moment resisting)	Stiff bay Rigid box Structural panel Permanent rigidity of structure	Tight and secure fixings	No extraneous parts or tackle Would usually form part of permanent structure	Erection stresses may exceed permanent case Not always practicable to effect final alignment and tightening at an early stage	Check on continuing adequacy may be required Temporary support may be required until final connection made

Table 2 — Types of support for providing stability and their applications (see notes 1 to 6)

Types of support	Possible applications	Requirements for effectiveness	Advantages	Disadvantages	Other considerations
D. Embedded anchorages and column bases	Single columns Portal frame Structural panels	Tight and secure fixings and wedges Symmetrical and stable packs under bases Securely embedded fixings resistant to displacement once fixed	No extraneous fittings to obstruct other activities	Adequacy of constructed fixings cannot be checked readily Pull-out of bolts may be a problem if not properly fixed and pull-out values may have to be tested High degree of accuracy in setting out required	Often the construction of these anchorages is by organizations other than the erection contractor and requires planning, coordinating and checking to help minimize difficulties
E. Shear resisting elements and panels (e.g. walls, floors and roofs)	Stiff bay Rigid box Permanent rigidity of completed portion of frame	Adequately developed strength, including mortar, concrete and fastenings, where appropriate Temporary supports required until strength developed	Forms part of permanent structure Extraneous fixings may not be required Extra or temporary equipment may not be required Temporary supports can be released for other work	Delay while strength of mortars and concrete develops Would depend on other trades for construction	A clear system of responsibility would have to be established to permit the removal of the temporary supports Requires careful planning and coordinating
F. Temporary structures (purpose built)	Any individual member, assembly or group	Sufficiently strong temporary structure to withstand forces Adequate distribution of forces within temporary structure Adequate local strength for fixings Effective connections	Can be designed to avoid the need for other support systems which may hinder the erection process	Purpose built temporary supporting structure has to be designed and erected May require special foundations	A clear system of responsibility would have to be established to permit the removal of the temporary structure Requires careful planning and coordinating
NOTE 1 Some supports will provide restraint either in tension only or in compression only. This can depend either upon the support itself or the type of end connection. Care has to be taken to identify this in the type of restraint chosen.					
NOTE 2 To give effective support in more than one direction it is usually necessary to provide restraints at, for example, 90° to each other.					
NOTE 3 When using external supports excessive force should not be used as this could itself induce instability.					
NOTE 4 A distinction has to be made between supports which are to be provided to resist loads and those such as jacking which are intended to aid erection by deliberately moving the structure or a component part, as this can adversely affect the structure, means of support or fixings.					
NOTE 5 Where an existing structure is to be relied upon to provide support, it should be capable of resisting the imposed loads.					
NOTE 6 Where temporary supports could be mistaken for part of the permanent structure, painting in a different and distinctive colour will aid identification. This will help to avoid the removal of permanent components by mistake when the temporary supports are removed.					

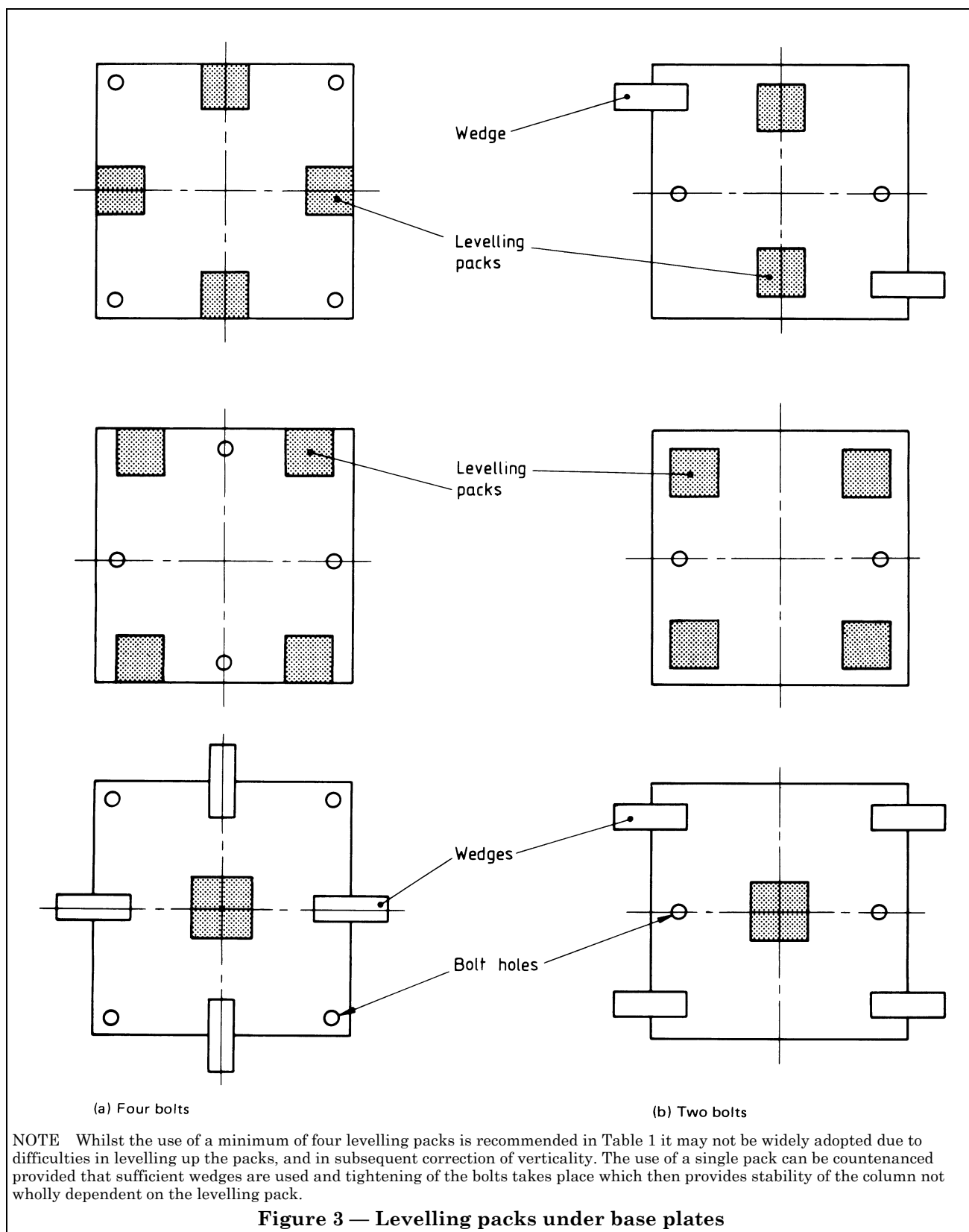

Licensed Copy: Rupert Heygate-Browne, Agip KOC, 10 February 2004, Uncontrolled Copy, (c) BSI

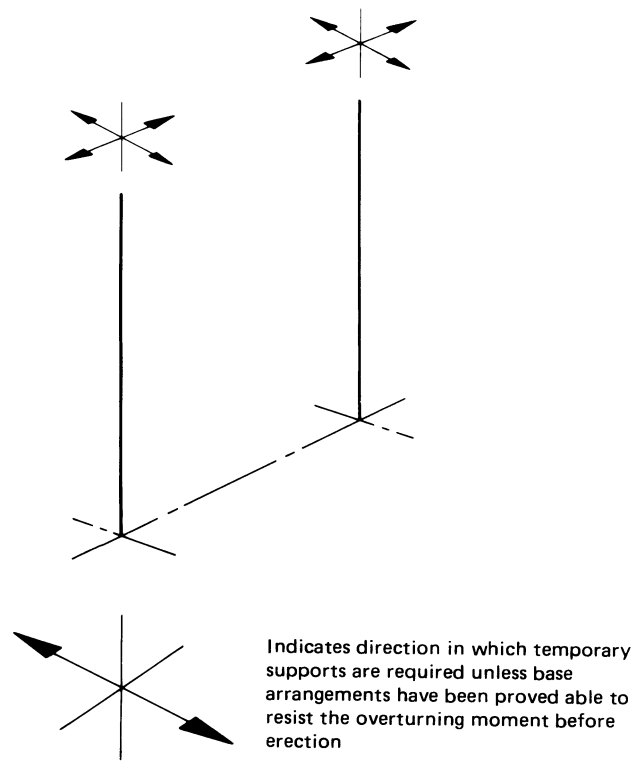

Figure 4 — Stability of single columns (diagrammatic representation)

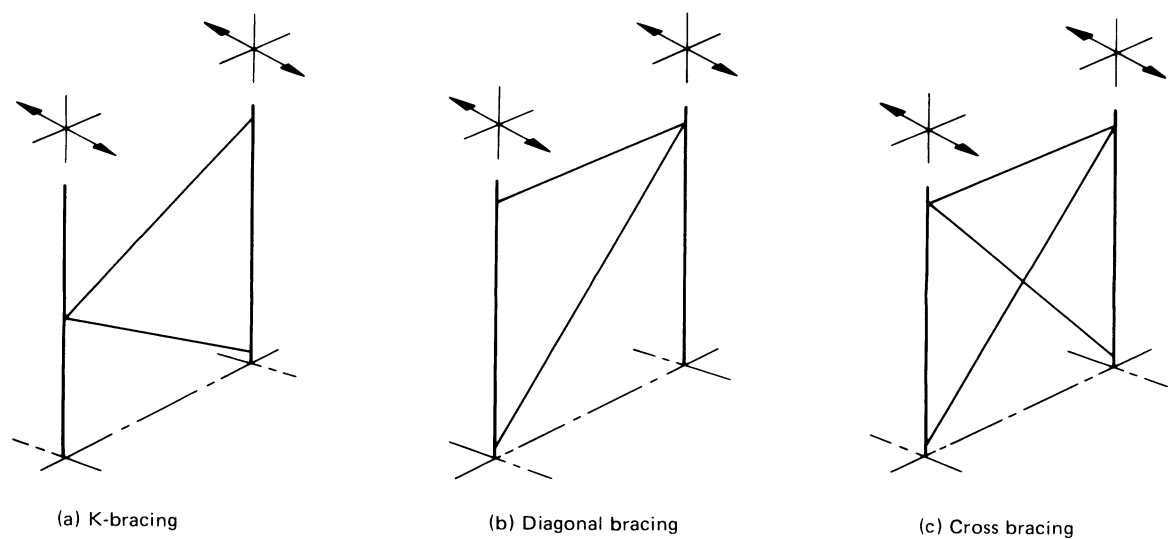

Figure 5 — Stability of single bays: braced (diagrammatic representation)

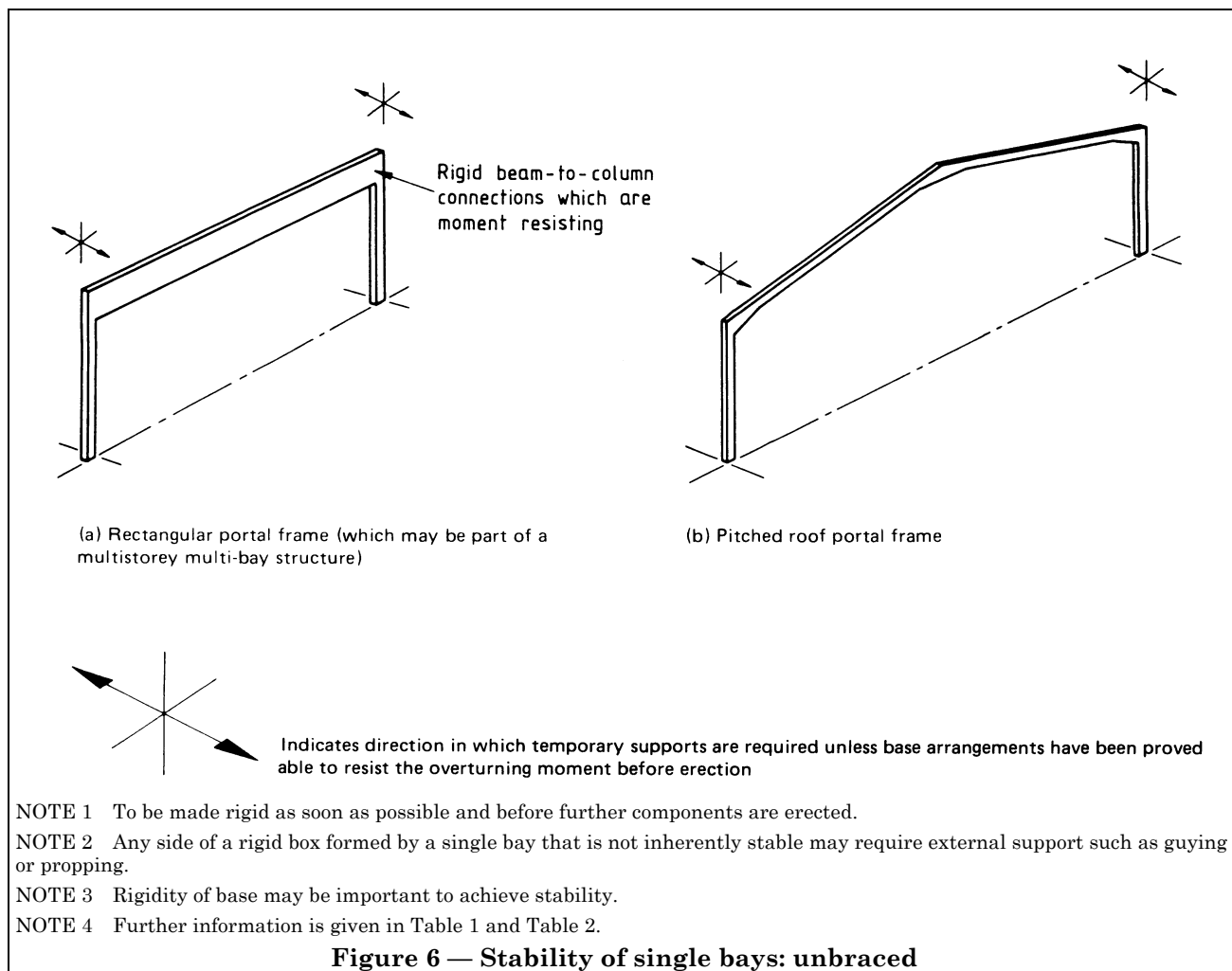
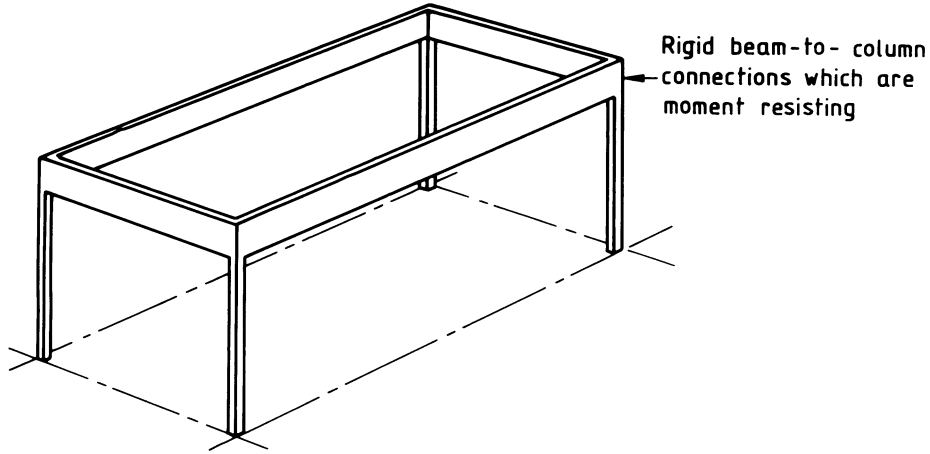
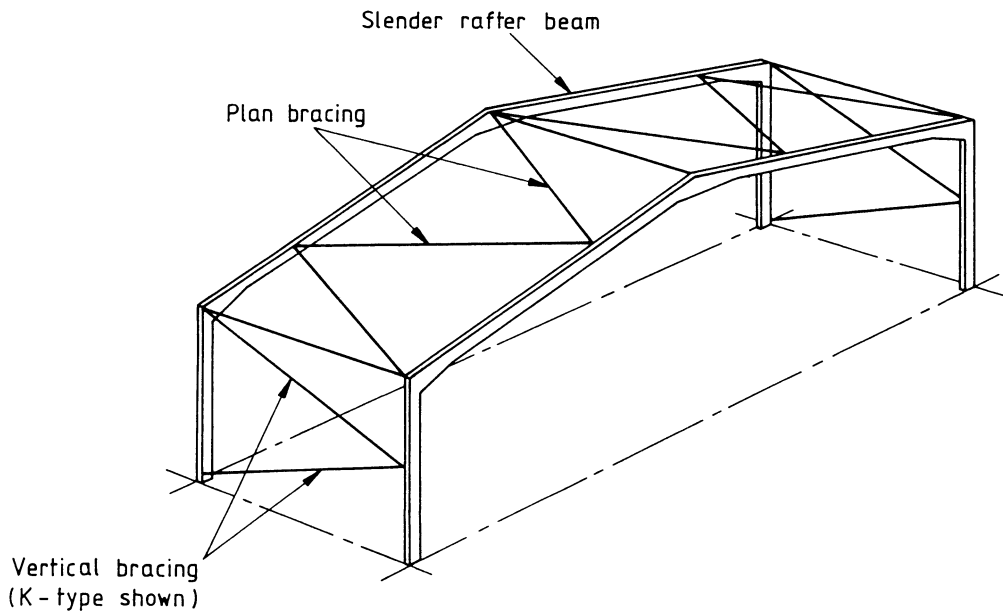

Figure 6 — Stability of single bays: unbraced



(a) Rectilinear frame



(b) Portal frame with vertical and plan bracing

NOTE 1 To be made rigid as soon as possible and before further components are erected.

NOTE 2 Any side of a rigid box formed by a single bay (see Figure 5 and Figure 6) that is not inherently stable may require external support such as guying or propping.

NOTE 3 Rigidity of base may be important to achieve stability.

NOTE 4 Further information is given in Table 1 and Table 2.

Figure 7 — Stability of rigid boxes

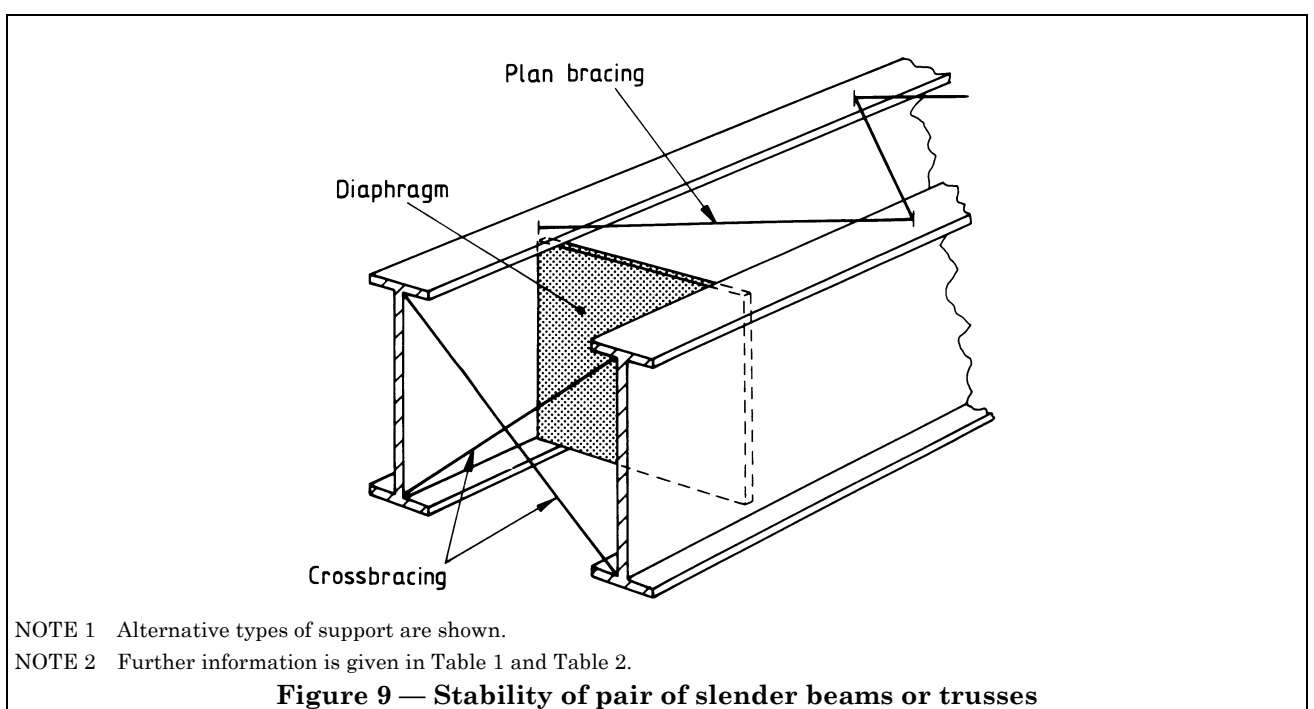
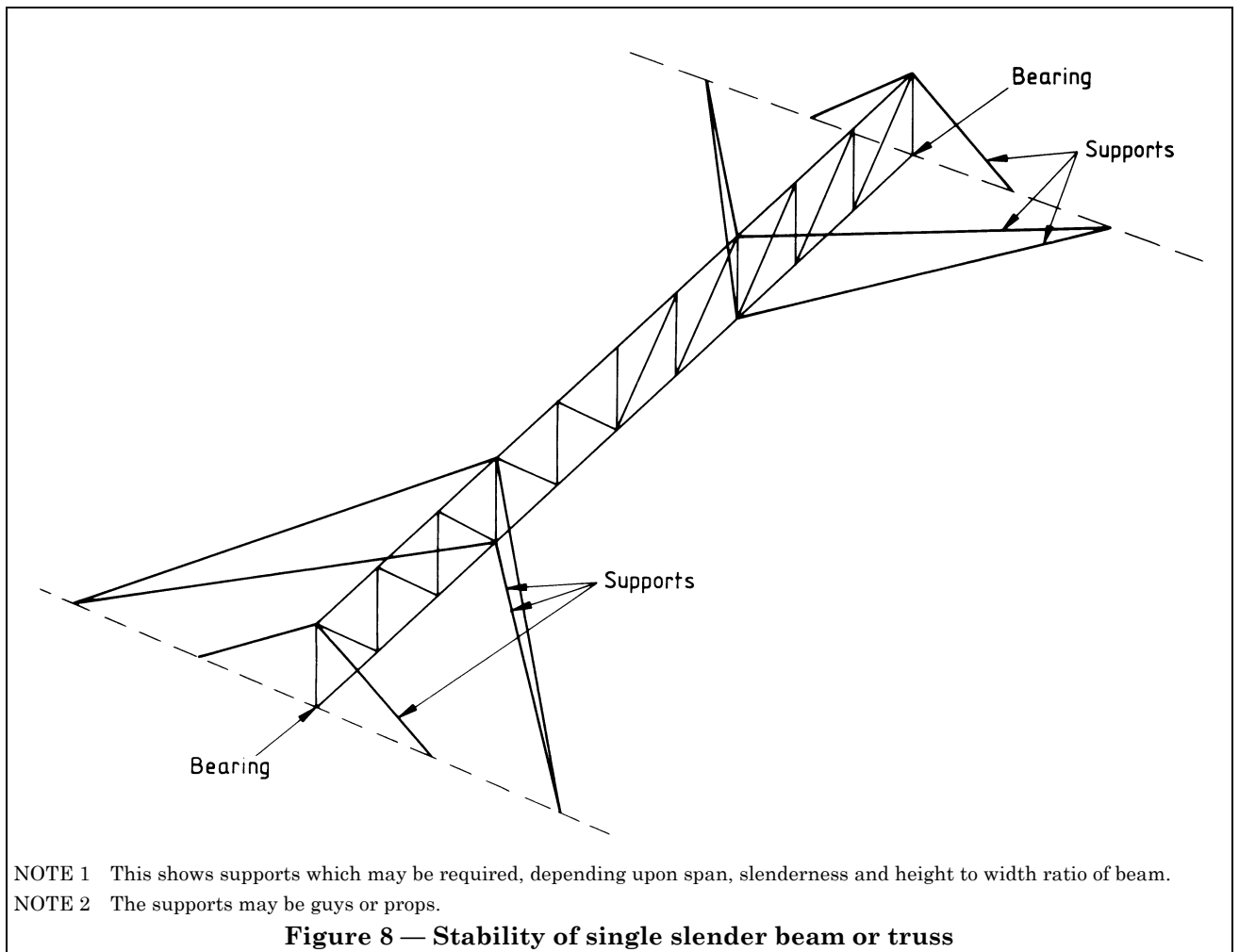

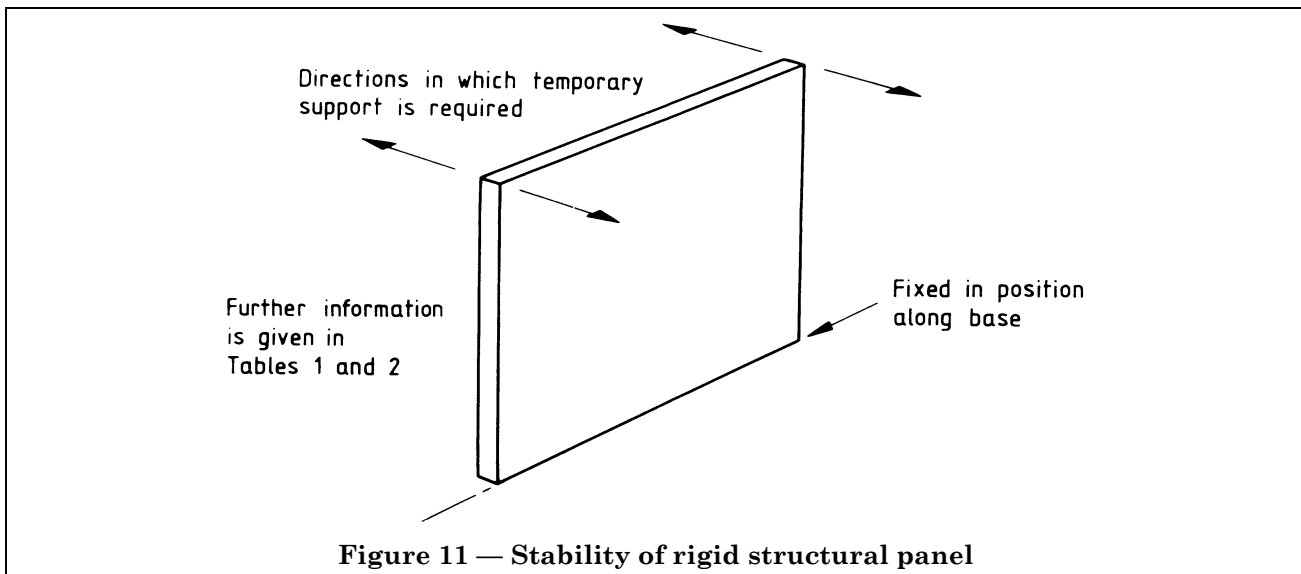
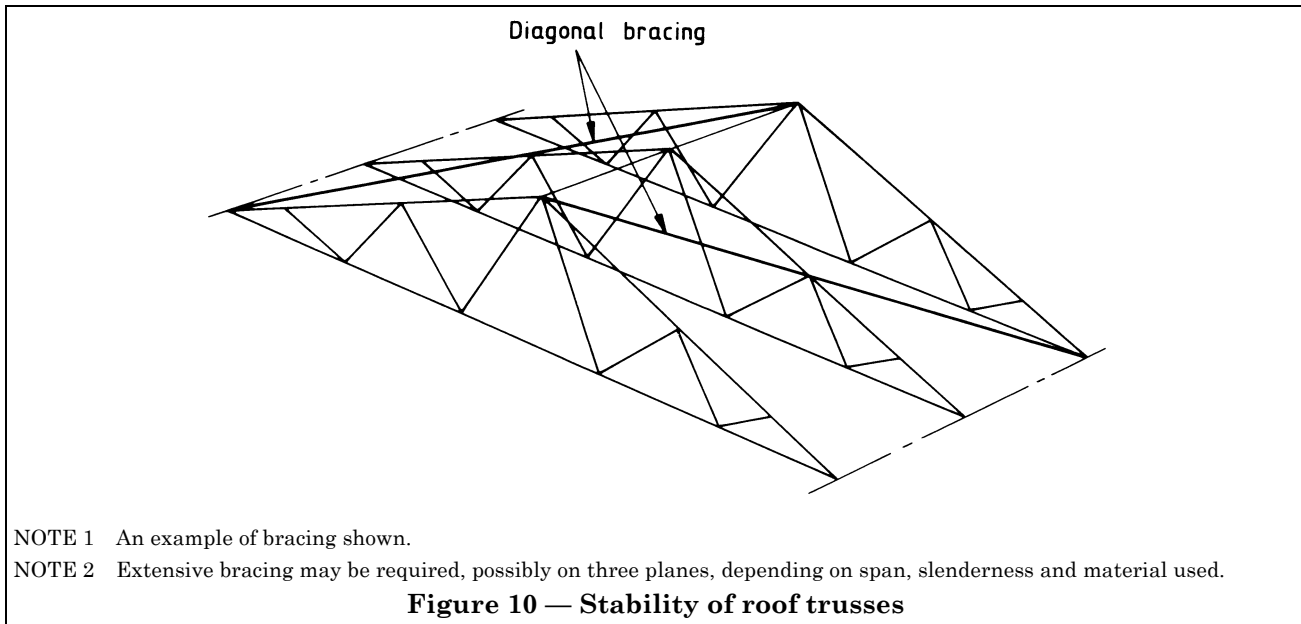

35 Precast concrete frameworks

35.1 General

The general principles of erection recommended in section 3 should be followed. Considerations peculiar to precast concrete frameworks are given in this clause.

35.2 Characteristics

35.2.1 Weight. Weights of components should be available on site. Whenever it is anticipated that erection personnel may be unfamiliar with the heavier components they are to handle, those components should be marked with their weights.

35.2.2 Transport and handling. Because quality control and manufacturing supervision are more readily exercised in factory production, precast components are often made at some distance from the place of erection and a need arises for special equipment for lifting, handling and transport. Vehicle loads should be secure at all times. Loading and unloading sequences are important and should be carefully planned to ensure that persons engaged in this operation are not put at risk. When vehicles are unloaded at site, a firm and level standing should be selected or prepared and the unloading should be carried out under competent supervision. In no circumstances should lifting slings be released from a deposited unit before it has been made stable.

35.2.3 Lifting and fixing. The centres of gravity of some of the unusual structural shapes are not always easily determined. Lifting points should be located to ensure balance.

For lifting columns the use of a separate beam and a lifting bar which can be remotely extracted from a prepared hole in the unit is recommended.

Some structures may be cast on site and lifted into position by tilt up processes using multi-point lifting techniques. This specialized method has to be made clear and understood by those involved.

Members should be marked when there is a risk that they may be erected the wrong way up or the wrong way round.

35.2.4 Strength. External appearance does not provide a reliable guide to strength or quality (e.g. the existence, size and placing of reinforcement and the security of anchorages for lifting are not visible in a completed member). The impact strength of concrete is considerably lower than that of low carbon steel and damage is more readily sustained.

35.2.5 End bearings. It is particularly important to ensure that the specified bearings are achieved. Wherever possible positive connections which prevent one unit sliding off another should be used. The accurate placing of reinforcement at bearings should be controlled by the manufacturer. Any bearing packs used on site should be of adequate size and correctly positioned to ensure proper transfer of load.

35.2.6 Workmanship and tolerances. Due attention should be paid to manufacturing and erection tolerances when planning the design and erection of the structure.

Joints in precast concrete members may be complex in order to ensure efficient load transfer. Reliability of the interconnections will depend on the standard of workmanship and tolerance in the manufacture. The joints should be capable of developing their strength with the least possible delay so that the period in which any part of the structure requires temporary support is as short as practicable. Joints which depend upon the lap welding of projecting reinforcing rods are not recommended because of the difficulty of securing a consistent and reliable connection.

35.3 Prestressing

35.3.1 General. Prestressing involves the control of considerable forces. The work should be undertaken only by experienced personnel under the control of competent supervision. For detailed recommendations reference should be made to BS 8110 and the equipment supplier's safe operating instructions.

35.3.2 Protection of persons in the vicinity. All persons other than those engaged in stressing work should be kept away from the jacking points and anchorages involved. Persons should never stand in line with jacks or anchorages while stressing is in progress.

The zone immediately behind the jack should be protected by a strong screen. A clear sign should be displayed, complying with BS 5378, e.g.

“CAUTION — STRESSING IN PROGRESS — KEEP CLEAR”

and measures should be taken to keep persons not engaged on the stressing away from the area.

35.4 Grouting of cable ducts

It may not always be appreciated that grout under pressure may set prematurely with the consequent likelihood of voids in the duct. It is essential to allow sufficient holes to ensure that the grout is flowing and to check any rise in pressure.

35.5 Portal frames

35.5.1 General. In the majority of portal frame designs the connections between purlins and rafters and also between eaves beam and column have relatively little rigidity. Many of them perform as pinned joints. The result is that if great care is not taken to support the columns firmly at foundation level and to support the frames by props or guy ropes at appropriate stages of erection the frames of a building are liable to collapse and fold longitudinally.

In order to reduce this risk of collapse and improve stability it is an advantage for cross bracing to be introduced in the first bay to be erected.

A sound foundation is necessary for each column; it should be capable of accepting both the vertical load and also the horizontal thrust which is developed as soon as erection props have been removed.

With most precast concrete portal frames, the columns are usually inserted into sockets cast into the foundation blocks and consequently require to be held temporarily in place after alignment. Wedges may be used for this purpose until the column has been made secure by grouting. Before this is done there is need for temporary support.

In some types of precast concrete portal frame a steel baseplate may be used similar to the base of a steel portal frame. Temporary support will also be required in this case. (The recommendations for steel erection procedures given in 37.5 should be followed.)

35.5.2 Erection sequence. A recommended erection sequence is given below (this assumes a socket base fixing as in Figure 12 and Figure 13).

a) Erection should commence with the corner column of a braced bay (see Figure 7), the erection packs having previously been levelled. The preferred method of lifting is by means of a shackle using a lifting hole near the top of the column.

b) The socket to receive the foot of the column should be completely clear of obstruction before the lifting of the column commences.

c) When placed in the socket, the column should be made secure by inserting wedges at the base and by propping the column in position. At this stage care should be taken to ensure that the column is located as near as practicable to its final position before release of the crane. The wedges should be used on all four sides. If wooden wedges are used they should have adequate contact area (i.e. there should only be a small degree of taper, preferably not more than 1 in 14). The props should be of the push-pull type to facilitate alignment operations and should be positively fixed to the column and to the ground or floor slab.

d) The remaining columns to form the braced bay should then be erected in the same way.

e) Cross bracing may then be fixed between the columns followed by eaves beams.

f) Depending on the span, it may be appropriate to lift the first rafter in one piece and fasten it to the columns, propping and guying it before releasing the lifting tackle.

If the rafter has to be erected in two portions the same principles will apply and the method is illustrated in Figure 12.

g) The rafter to complete the second portal should be erected in the same way. Permanent rafter bracing should be installed.

h) Any single span purlins in this bay should now be fixed.

i) Final alignment of the columns in the completed portion of the framework can now take place. This may be achieved by using pilot columns or profiles in advance of the erection. When columns are in their correct position the bases should be grouted or concreted as appropriate. Care should be taken not to disturb the wedges or props.

j) The temporary cross bracing between columns should remain in position until such time as sufficient of the permanent structure has been erected to ensure stability. In some cases further temporary bracing of intermediate bays may be necessary.

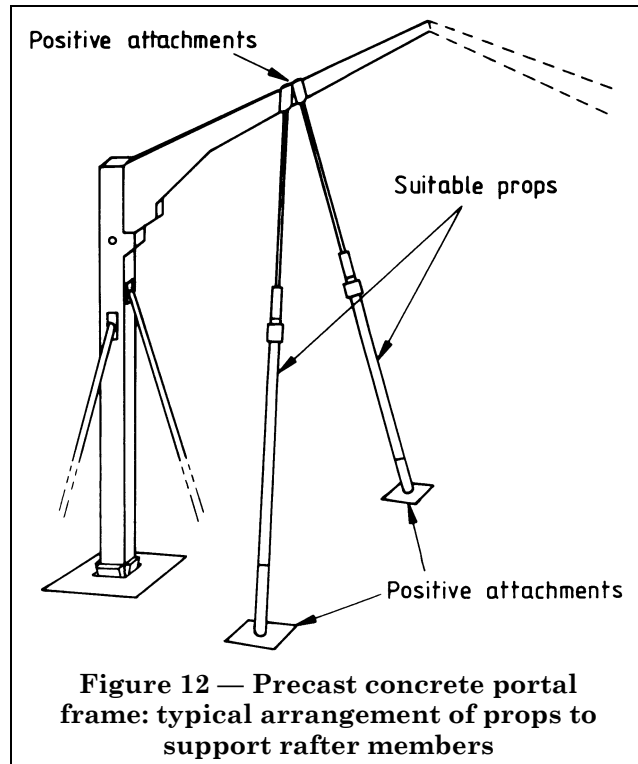

Figure 12 — Precast concrete portal frame: typical arrangement of props to support rafter members

k) Multi-span buildings should be erected in the same way, one span of two frames being completed and grouted at a time before any adjoining erection is undertaken.

35.5.3 Details. Typical construction details are shown in Figure 13.

35.6 Rectilinear frames: beam and column construction

Although permanent stability of rectilinear frames can be provided by internal cores or shear walls, it should be remembered that the provision of temporary propping and bracing, as specified in the typical erection procedure for portal frames, may still be necessary. Where this is the case the principles stated in 35.5 should be followed. When stability is provided by internal cores and shear walls it is important that the correct sequence of construction should be determined and strictly followed.

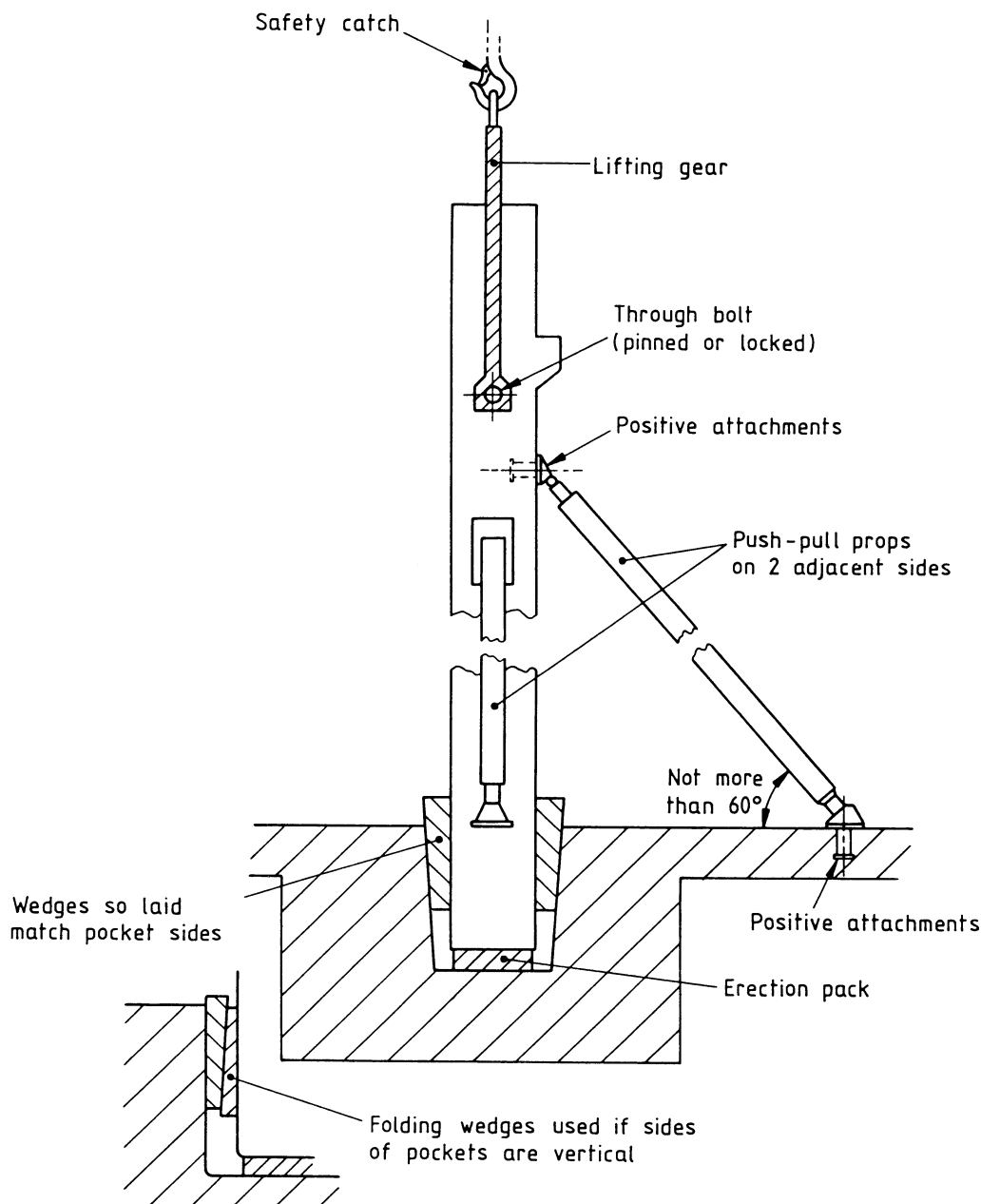

Figure 13 — Precast concrete column: typical bracing arrangement

35.7 Frames incorporating panel units

35.7.1 General. There are many proprietary kinds of panel-type construction in which components differ widely in shape and size. While procedures for erection may vary correspondingly, the following particular safety recommendations apply in addition to the general ones already given.

b) Wherever possible guardrails should be positioned to allow subsequent work to be carried out without the need for their temporary

35.7.2 Special provisions. Provision should be made at the design stage for the following.

a) Lifting attachments in floor units should, if possible, be incorporated in recesses in the unit. When this is not possible a projecting hoop may be used and should be burned off or bent down immediately after erection. Such hoops should be of low carbon steel and should be located in the plane of the applied force. removal.

35.7.3 Movement. During erection, check ropes should be attached to panel units to control movement.

35.7.4 Access. When access is prevented, for example after the erection of the final panel in a cross wall, the use of “up and over” ladders should be considered.

35.7.5 Lift-slab type construction. In types of construction in which a precast floor or portion of a framework is cast at ground level and raised into position, particular attention should be paid to the means of stabilizing the structure while lifting is in progress. No person should be present on any part that is being lifted or immediately underneath it. No additional loads should be imposed on parts which are being raised. Checks should be made to ensure all parts to be lifted are free to move and when they move equal travel is occurring at all points.

In manufacture of slab-type floors cast at ground level it is essential that the floor should not be lifted until it has gained adequate strength throughout. Nor should it be lifted until it has been verified that the floor is not adhering to any concrete slabs or portion of the foundations below.

Permanent anchorage or attachment of the raised parts should be completed before the lifting equipment is released.

36 Bonding

The use of adhesives for the jointing of precast concrete sections together and the use of joint fillers may cause a toxic reaction. They have to be used strictly in accordance with the manufacturer's instructions.

37 Steel frameworks

37.1 General

The general principles of erection recommended in section 3 should be followed. Considerations peculiar to steel frameworks are given in this clause.

37.2 Identification

Differences in the grade of steel are not visually evident. Similarly variations in the dimensions of steel sections may not be obvious without careful measurement. The identification system used by the fabricator should be understood and followed during the erection. (See BS 4360.)

37.3 Matters affecting stability

37.3.1 In addition to the general recommendation on stability given in clause 34 the following should be borne in mind when erecting structural steel:

- a) the weight of persons applied to ties, purlins or rails;

- b) forces from ladders and erection equipment.

37.3.2 The characteristics of steel can permit the springing and straining of members into position but this practice should be avoided. Details of connections should be such that springing and straining of members into position is obviated, as this practice can induce considerable stresses and may affect the stability of the structure. If previously tightened joints are loosened, the effect on stability has to be checked and any necessary temporary erection arrangements carried out before such loosening.

For torqued and high strength bolts refer to 27.3.

37.3.3 The drawings of the structural framework should clearly indicate the minimum number and position of bolts required in erection to effect a safe initial connection (i.e. the number of bolts that have to be inserted and made secure before lifting slings or attachments supporting the member being secured can be safely released).

37.4 Adjustment after erection

If after erection some members appear to need adjustment, no attempt should be made to do the work in situ without taking adequate safety precautions beforehand. Ideally the members should be removed, but only after stability of the structure without them has been fully ensured. Once removed, members should be modified at ground level.

37.5 Portal frames

Because the designs of steel portal frames are of many kinds, procedures for safe erection differ in detail, especially for wide spans. The basic aim, however, should be to commence and complete the erection of an end bay or group of bays in which bracing has been incorporated before proceeding with the erection of the remainder of the structure. Components of the end bay or bays will require support until the bracing has been completed. Side rails and purlins should not be relied upon to provide stability.

When permanent bracings are included elsewhere in the building than in an end bay, erection should commence at the bay or group of bays where they have been incorporated unless temporary bracing is used.

Where the nature of the design precludes erection in the foregoing manner proper steps should be taken to provide alternative support.

37.6 Trusses and lattice girders

37.6.1 Stability. A roof truss when first placed in position on its end supports may be unstable. Lifting attachments should not be released until the truss or girder has been positively attached to provide restraint against overturning. It should be noted that normal purlin connections provide only a limited resistance to lateral movement. No reliance should be placed on connections made to other parts of the structure unless the connection can develop its full load carrying capacity, e.g. connections made to brickwork or concrete should be secure and resistance to displacement or withdrawal from new brickwork or concrete should be developed to an adequate extent.

The erection procedure should aim at the fixing of the first two trusses or girders complete with cross bracing and interconnections so as to provide a rigid and stable basic assembly. No subsequent erection work should take place until this initial stage has been completed.

37.6.2 Freedom of movement. The lifting path should be clear of obstruction. If necessary, tail or guide ropes should be used to ensure that the truss or girder does not encounter obstructions in course of hoisting.

37.6.3 Arrangements for lifting. The attachments made to the truss or girder for lifting should impose only those forces which have been allowed for in design. Lifting can cause load-reversal and overloading in certain members and properly designed lifting attachments (e.g. strong backs) may be necessary to ensure that overloading does not occur and buckling is avoided (see Figure 14).

37.6.4 Bearings. When a truss or girder is placed on bearings which are designed to provide freedom of movement, temporary restraints should be provided. Any temporary fastening of the bearings or of the truss or girder should be removed as soon as its permanent stability has been ensured.

Care should be taken that any thrust imposed on the bearings by a truss or girder when it is being landed in position does not create a displacement sufficiently great to cause hazard. Any displacement caused during the erection of a truss or girder should be rectified before the lifting equipment is released.

37.6.5 Restriction of loads. In the course of erection no accumulation of weight (e.g. from stacked components) should be permitted unless it has been taken into account in the erection scheme.

37.7 Rectilinear frames

In this category are the frames of multi-storey office and industrial buildings of various kinds including very heavy forms of construction with varying design features. As stability is often achieved through the rigidity of the connections, it is important that all joints should be fully completed as erection proceeds. Where the frame design does not provide stability through the structural connections, adequate permanent or temporary bracing should be provided, or, where applicable, connection should be made to an internal core. It is usual for beams to be lifted and brought sideways into position. Clearances should be adequate and erection joints and fastenings arranged so that the incoming beam can easily be landed on a safe bearing and be made secure quickly before the lifting gear is detached.

Grillages and stanchion bases should be concreted in place as soon as possible after alignment and levelling to ensure that there is no subsequent disturbance.

37.8 Open web beams (lattice beams and castellated beams)

Open sections possess much less shear strength than sections with a solid web and care should be taken to avoid overloading. They generally have limited lateral stiffness and are often used for long spans. Therefore lateral restraining members should be connected before the gear holding the beam is released.

37.9 Use of roofing and cladding sheets as diaphragm bracing

It is essential that the erection scheme should be rigidly adhered to for frameworks in which the diaphragm action of corrugated or troughed sheets or metal decking is used for bracing purposes. The erection scheme should take into account that structural stability is achieved only after the erection of the cladding or decking and until this has been completed temporary bracing or other measures to provide stability will be necessary.

Any deviation from the erection scheme should be subject to prior approval.

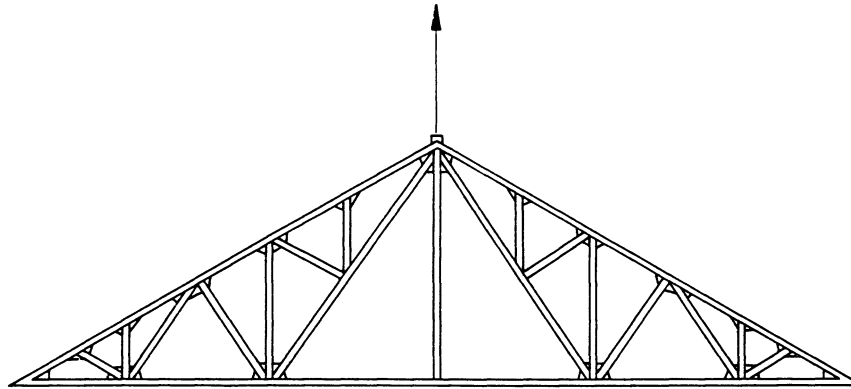

(a) Incorrect: bottom boom in compression and liable to buckle

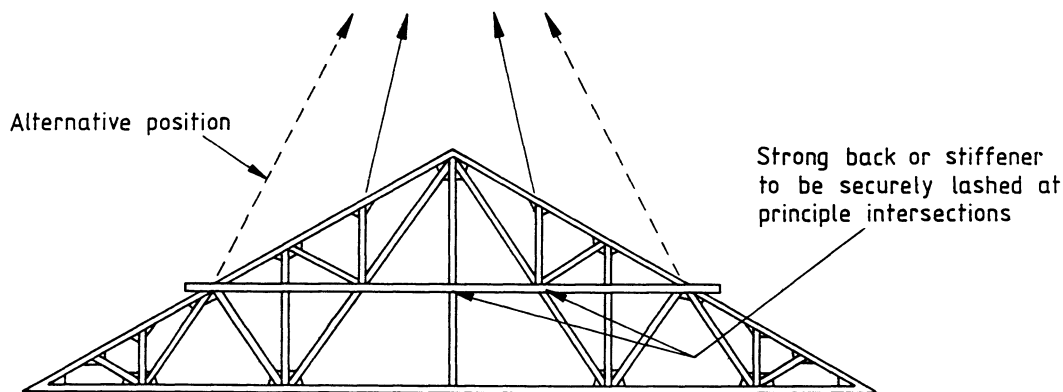

(b) Correct: strong back or stiffener used to prevent distortion

Figure 14 — Lifting of trusses

37.10 Suspended steel structures

37.10.1 The safe erection of suspension frameworks in which the structure is hung from a previously built central tower or "core" requires proper design consideration. The erection procedure should be planned in full detail to allow all operations to be performed safely. The following are some of the erection methods that have been used.

a) Erection from the top downwards using a suspended working platform extending over the whole floor area. The platform is built initially at ground level and it is then lifted by suspension cables to a point just below the upper floor level to allow the framework of this floor to be built. It is then lowered stage by stage to allow the floors beneath to be built successively.

b) Erection from the top downwards by building floor framework units at ground level immediately below their final position and then lifting directly upwards on a suspended carriage and coupling in position. This method has the advantage of limiting the number of operations which steel erectors have to carry out at height.

c) Erection from ground level upwards using temporary columns to support the first floor and then building upwards with the hanger members accepting dead load compression until final attachment is made to the overhead support points. The temporary ground floor columns can then be retracted and removed.

37.10.2 When temporary access ways and working platforms are provided, allowance should be made for the following:

- a) changes in level which are likely to take place at access points from the tower core as the load on the suspension members increases with construction progress;
- b) clearance between the framework and the core to cater for movement caused by wind. Restraint may be necessary to restrict swinging and prevent jamming.

37.11 Composite construction

37.11.1 General. In situations where two materials are used in structural combination it is necessary for safety that each should contribute towards load carrying in the intended manner. The structural requirement should therefore be:

- a) clearly specified by the designer;
- b) understood by those concerned with the execution of the work;
- c) carefully supervised by those responsible for construction.

37.11.2 Propping as a structural design requirement. The design of a steel and concrete composite beam may be based upon any of the following three modes of action all of which depend upon the development of shear resistance between the component parts:

- a) no propping before placing topping (composite action develops for live load only);
- b) propping before placing topping (composite action develops for both dead load and live load);
- c) propping with pre-loading in opposite direction to that of normal loading (composite action develops for both dead load and live load).

Methods b) and c), which are used in the minority of applications, result in a basic steel framework which is lighter than with method a) (and considerably lighter than with conventional construction). Methods b) and c) therefore require props that are additional to any that are necessary for stability and it is important that these should be installed and made effective strictly in compliance with the erection scheme.

All props should be in position and suitably adjusted before any in situ concrete is placed and remain in position until the composite action is developed.

37.11.3 Use of precast and partly cased steel sections. The general safety procedures recommended for the erection of precast concrete frameworks should be followed where applicable in conjunction with the recommendations for the erection of steel frameworks contained in this section. Account should be taken of the increased weight of precast sections and its effect on sway forces and the adequacy of the initial connections.

37.11.4 Shear connectors. Welding can be carried out at the fabricator's works but if done on site it should be after temporary decking or permanent flooring has been erected in order to provide a safe working platform. Where such work is carried out on site reference should be made to **25.1**.

38 Space frameworks

38.1 General

The general principles of erection recommended in section 3 should be followed. Considerations peculiar to space frameworks are given in this clause.

The classification "space frameworks" includes a wide variety of braced frameworks which have been designed to function in three dimensions. This form of construction is particularly appropriate for wide span roof structures and the recommendations in **38.2** to **38.6** apply principally to double layer grid roofs, domes and braced barrel vaults. The recommendations for safety are somewhat different from frameworks of other types.

38.2 Methods of erection

38.2.1 Several methods of erection are possible but there are three main types of procedures as described in **38.2.2** to **38.2.4**.

38.2.2 Assembly in final position (on centring or falsework).

38.2.3 Assembly near ground level and hoisting, either

- a) freely without fixed lateral constraint; or
- b) from a framework affording fixed lateral support for the duration of the hoisting.

38.2.4 Assembly in stages at or near ground level and either:

- a) lifting in parts to the final position; or
- b) lifting in stages as a core to which successive stages are attached.

38.3 Assembly in final position

The falsework supporting the structure should be designed to withstand all the forces induced in the erection process. Where in the course of erection secondary members are required to span further than will be the case in the final structure, the falsework should be strengthened at the support positions to carry the additional dead weight. This situation may arise quite frequently as it is normally not economic to provide a support for every node in a double layer grid or dome structure.

Proper means of access (i.e. temporary platforms and stairways) should be provided for the purposes of erection, welding, bolting and painting and also for use by persons engaged on subsequent finishing trades including the installation of services, false ceilings, lighting, etc.

Wherever possible the staging and temporary access platforms should be removed by the contractor responsible for erection only when the whole of the overhead finishing work has been completed and no further need for overhead access arises.

38.4 Assembly near ground level and hoisting

38.4.1 Hoisting freely without fixed lateral constraint. The lifting points should be positioned so that the structure is stable in the course of hoisting. Either a synchronized lifting arrangement should be installed (e.g. with jacks) or there should be independent hoisting with not more than three main points of application.

A fully detailed analysis should be performed to determine the load distribution in the structure for the proposed lifting condition so as to ensure that during hoisting permissible erection stresses are not exceeded or deformation leading to local instability does not occur especially near the lifting points.

Temporary connecting ties should be used to prevent spreading of the edge members of braced barrel vaults.

Lifting attachments to the structure should always be located at node points.

38.4.2 Hoisting from a framework affording fixed lateral support. A synchronized lifting method should be employed, preferably from or near the final support positions.

A fully detailed analysis should be carried out in the event that lifting is to be performed from fewer positions than there are final supports or if the distribution of load is substantially different from that for the final support condition. The analysis should take into account the effect of lifting on the supports and on the substructure from which the lift is to be made. Temporary tie connections may be necessary with braced barrel vaults to prevent spreading of the edge members.

Throughout the lifting procedure competent persons should be present near each guide and lifting position to monitor progress and to ensure that no jamming occurs in the guides or hoisting apparatus. The guides should control the lateral movement of the structure in all directions and should be designed to provide clearance of not less than 12 mm after taking into account the most adverse combination of tolerances. The guide clearance should not be so great that there is undue freedom of lateral movement and consequent risk of snatching and jamming.

The vertical alignment and clearance of the guides should be verified before hoisting commences by careful and precise checking (e.g. using optical instruments or sighting targets attached to the structure).

When the structure to be lifted is of sufficiently large size that visual or aural communication is not dependable a telephone or radio system should be installed so that the observer at each lifting and guide point is linked to a main lifting control position.

In the design, installation and use of the hoisting equipment and guides, allowance should also be made for dynamic effects in adjacent parts of the structure.

The hoisting equipment should include a fail-safe mechanical load holding device so that the structure being lifted can be maintained in position between lifts without reliance on hydraulic pressure or friction. The device should be so arranged that support is given to prevent downward movement but if the structure is light and subject to disturbance by wind, upward movement should be temporarily restricted as well. In this event the device should be so arranged that hoisting cannot be resumed without prior disengagement.

With a screw-type jacking system a temporary load holding device is not required when there is cessation of lifting at a point in the range of jack travel. Secure and robust load holding supports are nevertheless required for periods when the jack is retracted to allow re-engagement and the commencement of subsequent lift. The temporary load holding support should not restrain the structure against further lifting. If, however, the structure is light and subject to wind disturbance there should be a holding down arrangement such that power for lifting cannot be re-applied until all restraint has been removed.

In the event that the structure is being hoisted from an existing or partially completed substructure the lifting zone should be guarded by handrails until the lifting operation is complete.

38.5 Assembly in stages

38.5.1 Lifting in parts to the final position. The assembled elements of the structure should be lifted into position in the manner described in 38.4.1 and lifting precautions should follow the same pattern.

Detailed calculations should be performed to ensure that for the proposed sequence of lifting there is no general or local overstress at any stage of the lifting or in the connection of the part to the main structure. Connections between successive parts should preferably be dead seated.

38.5.2 Lifting in stages as a core. The progressive lifting of the core should be undertaken by either the method described in 38.4.1 or in 38.4.2 and the stated precautions observed. Additionally the core should be stabilized between lifts before new components are added to form the next stage.

38.6 Erection stability

In situations where the stability of the finished structure depends partly or wholly on the cladding, temporary supports should not be withdrawn until the whole of the cladding is securely fixed. This is particularly important for a ribbed dome. Exact alignment of members should be achieved as far as possible. In frameworks where diagonal bracings are omitted or minimal in number, misalignment of members in course of erection can lead to instability.

39 Timber frameworks

39.1 General

The general principles of erection recommended in section 3 should be followed. Because of the characteristics of timber frames as described here the specified handling and erection procedures should not be varied and any temporary reinforcement necessary should be provided.

It is essential to erect edge protection to open sides as the work progresses.

39.2 Characteristics

39.2.1 Lightness. Elements lifted into position may be of considerable size and therefore prone to disturbance by wind. Manhandling a panel of any light material can be highly dangerous in wind and such components should at all times be kept under positive control.

39.2.2 Flexibility. Elements, which may not necessarily be fully braced in element form, are likely to have only a limited amount of torsional and lateral rigidity; they may thus require an appreciable amount of temporary bracing especially if of significant size (e.g. floor panel assemblies).

39.2.3 Surface condition. The nature of the wood or the surface condition or both may introduce a handling hazard (splinters).

39.2.4 Prefabrication. Prefabricated systems often depend on joints between sections for stability and rigidity. It is therefore essential that such connections are made as the erection progresses or other measures, temporary props for example, are used to ensure stability.

39.3 Stability in erection

In some designs lateral stability may be provided by the cladding and a framed structure may not be safe until covering panels are fixed. In situations where panels affording stability are to be added after erection of the framework, equivalent stability should be provided by temporary supports until such time that the panels are fixed.

Where stability depends on the presence of monolithic portions of the structure constructed in situ (e.g. in brickwork or concrete) these portions should be present to perform their function at the time that the framework is erected. Alternatively, an effective form of temporary bracing is necessary to resist lateral forces until the permanent work is ready.

39.4 Wind

Adequate restraint to the effect of wind should be present at all stages of construction. Particular care is necessary in respect of:

- a) panel-type components stacked prior to erection;
- b) partly clad or partly erected portions of framework;
- c) anchorage at critical points (e.g. holding down to the ground and eaves junctions of rafter members, especially of low-pitched roofs).

39.5 Trussed rafters

While trussed rafters have considerable strength in their own plane they are very liable to twist and buckle. It is necessary in erection to prevent undue distortion and when mounted in position the rafter and tie members should be adequately restrained.

39.6 Stressed-skin type structures

In such structures the surface portions have a structural or load-bearing function to perform. Construction in this category includes lamella structures, domes, barrel-vault shells, hyperbolic paraboloids and folded-plate structures.

The tendency for edges of shell or folded-plate elements to spread apart or otherwise distort before adjoining elements are fixed should be anticipated. Temporary ties or other forms of restraint are frequently necessary.

40 Aluminium frameworks

40.1 General

The general principles of erection recommended in section 3 should be followed. Considerations peculiar to aluminium frameworks are given in this clause.

NOTE The term "aluminium" includes aluminium alloy.

40.2 Characteristics

40.2.1 Lightness. Aluminium has approximately one-third the density of steel. Consequently framework elements may be lighter or of increased size. Partly or fully clad elements may thus be susceptible to the effect of wind to a greater extent than when made in steel.

40.2.2 Flexibility. Because the modulus of elasticity of aluminium is only about one-third that of steel for corresponding strength, structural elements and completed frames are likely to possess a reduced amount of torsional and lateral stability and will normally require additional temporary support.

Due allowance should be made for deflection in the course of erection, e.g. horizontal members or rails may need increased rigidity to carry safely the weight of a person or a ladder.

40.3 Heat-treated alloys and work-hardened alloys

The heat-treatment or work-hardening processes in manufacture, on which aluminium structural members depend for their strength, restrict the amount of cold forming which may subsequently take place. The amount of bending that may safely be performed is thus limited. The application of heat at site should not be allowed, except under expert supervision, for the same reason. Flame cutting is not permissible in any circumstances.

40.4 Welding

Welding is normally performed only at works under controlled conditions and special consideration should be given to any site welding being undertaken.

40.5 Effect of weather on aluminium screw threads

The effect of exposure to the weather can make it difficult to unscrew aluminium bolted connections. Where erection or subsequent dismantling will require an aluminium bolted connection to be unscrewed, the threaded portion of the bolt and plain portion of the shank should be coated with lanolin or grease at the time of original assembly.

41 Plastics frameworks

41.1 General

The general principles of erection recommended in section 3 should be followed. Considerations peculiar to plastics frameworks are given in this clause.

Plastics framework elements are generally of panel form because of their very low modulus of elasticity compared with other structural materials. These panels are sometimes flat but otherwise of folded or curved shape to permit the skin to perform a structural function normally in conjunction with stiffening ribs.

41.2 Characteristics

41.2.1 Extreme lightness. The component parts to be handled and lifted have a density that is far below that of metals and sometimes lower than that of wood. They are therefore very light. Mechanical lifting gear may thus not be necessary and the work may be undertaken manually. Wind effects are likely to be of considerable significance. A positive form of restraint should be provided for each element to allow handling, lifting and fastening to be performed safely without risk of erection personnel being thrown off balance by a gust of wind.

41.2.2 Flexibility. The low modulus of elasticity tends to make large framework elements particularly flexible and prone to lateral and torsional movement. Temporary supports are desirable with early interconnection of adjoining parts.

41.2.3 Low impact strength. Plastics materials are not able to absorb energy in plastic deformation in the same way as metals although their capacity for energy absorption in the elastic range is quite good. A sharp blow can cause fracture or penetration and if this happens at a point on the connecting flange of a component the strength and safety of the connection will be seriously impaired. It is therefore particularly important to ensure that framework components are not dropped and do not suffer impact.

41.3 Prefabrication

Frame elements normally consist of framed panels which may be flat, curved or folded and interconnection of the boundaries brings about the formation of the main frame.

Effective and progressive interconnection in the course of site assembly is thus essential if rigidity is to be developed in the manner intended.

41.4 Fire precautions

Plastics may be combustible. Stacks of components should therefore be limited in size and arranged in such a way that fire fighting equipment can be used. No flame cutting or welding operations should be allowed to take place in proximity.

41.5 Stability in erection

In a plastics structure the stability of the whole assembly is usually dependent upon the presence of all the component parts. In the course of erection it is often necessary to provide temporary supports so that deflection due to dead load stress does not prejudice the proper fitting together of the parts.

For safety in erection it is necessary to ensure that:

- a) at all stages sufficient anchorage and interconnection is present to resist wind force, including its lifting force;
- b) temporary supports of adequate strength in both tension and compression are present and properly fixed;
- c) parts are secured or stabilized to prevent wind vibration.

41.6 General precautions

41.6.1 *Danger from wind.* Considerable danger may arise when handling and erecting plastics components because parts that can be safely handled in the absence of wind may become uncontrollable even in moderate wind conditions. Strong gusts of wind can introduce very serious handling hazards. The erection procedure adopted at the site should therefore recognize these risks and work should not be carried out in gusty conditions. In light to moderate winds it may be necessary to augment the erection team. If lifting gear is used a sufficient number of guy lines should be attached to the elements being lifted to allow full control to be achieved. Extra care should be exercised in the manual handling of plastics components in locations above ground level. When components are stored on site or are waiting for erection, they should be held down to prevent them from being lifted up or blown about by the wind.

41.6.2 *Risk due to damage and handling.* Plastics components are not able to resist high levels of local stress safely and their impact strength is limited. It may therefore be highly dangerous for persons to walk on plastics roof panels or to tread on flanges not designed to accept point loads of this type. In these cases suitable walkways should be provided. Attempts to rectify by force dimensional inaccuracy in the course of erection should only be undertaken with considerable care and with competent supervision.

Plastics surfaces are usually smooth and do not offer safe hand or foot holds. Care should be taken in using ladders.

When handling plastics reinforced with glass fibre or steel wire, gloves should be worn.

Publications referred to

- BS 638, *Arc welding power sources, equipment and accessories.*
- BS 1397, *Specification for industrial safety belts, harnesses and safety lanyards.*
- BS 3294, *Specification for the use of high strength friction grip bolts in structural steelwork.*
- BS 3913, *Specification for industrial safety nets.*
- BS 4360, *Specification for weldable structural steels.*
- BS 4604, *Specification for the use of high strength friction grip bolts in structural steelwork. Metric series.*
- BS 4870, *Specification for approval testing of welding procedures.*
- BS 4898, *Specification for chain lever hoists.*
- BS 5062, *Self-locking safety anchorages for industrial use.*
- BS 5062-2, *Recommendations for selection, care and use.*
- BS 5135, *Specification for arc welding of carbon and carbon manganese steels.*
- BS 5268, *Structural use of timber.*
- BS 5378, *Safety signs and colours.*
- BS 5950, *Structural use of steelwork in building.*
- BS 5975, *Code of practice for falsework.*
- BS 6100, *Glossary of building and civil engineering terms²⁾.*
- BS 8110, *Structural use of concrete.*
- CP 93, *Code of practice for the use of safety nets on constructional works.*
- CP 118, *The structural use of aluminium.*
- CP 3010, *Code of practice for safe use of cranes (mobile cranes, tower cranes and derrick cranes).*
- Health and Safety Executive Guidance Notes
- GS 5, *Entry into confined spaces³⁾.*
- GS 28/1-4, *Safe erection of structures³⁾.*

²⁾ Referred to in the foreword only.

³⁾ Available from HMSO.

BSI — British Standards Institution

BSI is the independent national body responsible for preparing British Standards. It presents the UK view on standards in Europe and at the international level. It is incorporated by Royal Charter.

Revisions

British Standards are updated by amendment or revision. Users of British Standards should make sure that they possess the latest amendments or editions.

It is the constant aim of BSI to improve the quality of our products and services. We would be grateful if anyone finding an inaccuracy or ambiguity while using this British Standard would inform the Secretary of the technical committee responsible, the identity of which can be found on the inside front cover. Tel: 020 8996 9000. Fax: 020 8996 7400.

BSI offers members an individual updating service called PLUS which ensures that subscribers automatically receive the latest editions of standards.

Buying standards

Orders for all BSI, international and foreign standards publications should be addressed to Customer Services. Tel: 020 8996 9001. Fax: 020 8996 7001.

In response to orders for international standards, it is BSI policy to supply the BSI implementation of those that have been published as British Standards, unless otherwise requested.

Information on standards

BSI provides a wide range of information on national, European and international standards through its Library and its Technical Help to Exporters Service. Various BSI electronic information services are also available which give details on all its products and services. Contact the Information Centre. Tel: 020 8996 7111. Fax: 020 8996 7048.

Subscribing members of BSI are kept up to date with standards developments and receive substantial discounts on the purchase price of standards. For details of these and other benefits contact Membership Administration. Tel: 020 8996 7002. Fax: 020 8996 7001.

Copyright

Copyright subsists in all BSI publications. BSI also holds the copyright, in the UK, of the publications of the international standardization bodies. Except as permitted under the Copyright, Designs and Patents Act 1988 no extract may be reproduced, stored in a retrieval system or transmitted in any form or by any means – electronic, photocopying, recording or otherwise – without prior written permission from BSI.

This does not preclude the free use, in the course of implementing the standard, of necessary details such as symbols, and size, type or grade designations. If these details are to be used for any other purpose than implementation then the prior written permission of BSI must be obtained.

If permission is granted, the terms may include royalty payments or a licensing agreement. Details and advice can be obtained from the Copyright Manager. Tel: 020 8996 7070.