

BS 5446-3:2015



BSI Standards Publication

# Detection and alarm devices for dwellings –

Part 3: Specification for fire alarm  
and carbon monoxide alarm systems  
for deaf and hard of hearing people

**bsi.**

...making excellence a habit.™

**Publishing and copyright information**

The BSI copyright notice displayed in this document indicates when the document was last issued.

© The British Standards Institution 2015

Published by BSI Standards Limited 2015

ISBN 978 0 580 81742 7

ICS 11.180.15; 13.220.20

The following BSI references relate to the work on this document:

Committee reference FSH/12/2

Draft for comment 14/30277275 DC

**Publication history**

First published April 2005

Second (current) edition, February 2015

**Amendments issued since publication**

<b>Date</b>	<b>Text affected</b>
-------------	----------------------

---

## Contents

Foreword	<i>iii</i>
Introduction	1
<b>1</b>	<b>Scope</b> 2
<b>2</b>	<b>Normative references</b> 2
<b>3</b>	<b>Terms and definitions</b> 3
<b>4</b>	<b>General requirements for alarm systems</b> 4
<b>5</b>	<b>Constructional and electrical requirements</b> 5
5.1	Electrical safety 5
5.2	Component interconnections 5
5.3	Connecting terminals 5
5.4	Battery connectors 5
5.5	Electromagnetic compatibility 5
5.6	Power supplies 5
5.7	Operation 7
5.8	Integrity 7
<b>6</b>	<b>Requirements for components</b> 7
6.1	Alarms 7
6.2	Control and indicating functions 8
6.3	Visual alarm device 11
6.4	Vibrating pad 13
6.5	Vibrating alerter 15
6.6	Low frequency sounder 18
6.7	Radio-linked system 19
<b>7</b>	<b>Marking</b> 21
7.1	Marking of alarm systems 21
7.2	Marking of individual components 21
<b>8</b>	<b>Provision of information</b> 22
8.1	Information to be provided with fire and carbon monoxide alarm systems 22
8.2	Information to be provided with individual components 23
<b>Annexes</b>	
Annex A (informative)	Alarm system grades 24
Annex B (normative)	Power supplies tests 24
Annex C (normative)	General procedures for tests 25
Annex D (normative)	Tests for control units 26
Annex E (normative)	Tests for radio-linked systems 28
Annex F (normative)	Tests for visual alarm devices 30
Annex G (normative)	Tests for vibrating pads 31
Annex H (normative)	Tests for vibrating alerters 37
Annex I (normative)	Tests for low frequency sounders 44
Bibliography	46
<b>List of figures</b>	
Figure G.1 – Test apparatus for measuring vibration intensity of vibrating pads	32
Figure H.1 – Test apparatus for measuring vibration intensity of vibrating alerters	39

**List of tables**

Table A.1 – Minimum components for fire and carbon monoxide alarm system grades	24
Table D.1 – Test schedule for control units	27
Table F.1 – Test schedule for visual alarm devices	30
Table G.1 – Test schedule for vibrating pads	31
Table H.1 – Test schedule for vibrating alerters	38
Table I.1 – Test schedule for low frequency sounders	45

**Summary of pages**

This document comprises a front cover, an inside front cover, pages i to iv, pages 1 to 46, an inside back cover and a back cover.

## Foreword

### Publishing information

This part of BS 5446 is published by BSI Standards Limited, under licence from The British Standards Institution, and came into effect on 28 February 2015. It was prepared by Subcommittee FSH/12/2, *Fire detectors*, under the authority of Technical Committee FSH/12, *Fire detection and alarm systems*. A list of organizations represented on these committees can be obtained on request to their secretary.

### Supersession

This part of BS 5446 supersedes BS 5446-3:2005, which is withdrawn.

### Relationship with other publications

BS 5446 is published in the following parts:

- Part 2: *Specification for heat alarms*;
- Part 3: *Specification for fire and carbon monoxide alarm systems for deaf and hard of hearing people*.

Smoke alarms for use in dwellings are specified in BS EN 14604. Carbon monoxide alarms are specified in BS EN 50291-1.

Guidance on the siting, installation and maintenance of smoke alarms for deaf and hard of hearing people in dwellings, and on user actions, is given in BS 5839-6.

Guidance on siting and maintenance of carbon monoxide alarms is given in BS EN 50292 for general use.

### Information about this document

This is a full revision of the standard, and introduces the following principal changes:

- inclusion of carbon monoxide alarms;
- change from “kits” to individual components that may be used to form a system appropriate to individual requirements or needs;
- inclusion of references to European standards for visual alarm devices and low frequency sounders;
- removal of requirements specific to LAVs;
- inclusion of guidance on systems suitable for varying levels of hearing loss.

*Product certification/inspection/testing.* Users of this British Standard are advised to consider the desirability of third-party certification of product conformity with this British Standard. Appropriate conformity attestation arrangements are described in the appropriate part of the BS EN ISO 9000 series. Users seeking assistance in identifying appropriate conformity assessment bodies or schemes may ask BSI to forward their enquiries to the relevant association.

### Use of this document

It has been assumed in the preparation of this British Standard that the execution of its provisions will be entrusted to appropriately qualified and experienced people, for whose use it has been produced.

### **Presentational conventions**

The provisions of this standard are presented in roman (i.e. upright) type. Its requirements are expressed in sentences in which the principal auxiliary verb is "shall".

*Commentary, explanation and general informative material is presented in smaller italic type, and does not constitute a normative element.*

Where words have alternative spellings, the preferred spelling of the Shorter Oxford English Dictionary is used (e.g. "organization" rather than "organisation").

### **Contractual and legal considerations**

This publication does not purport to include all the necessary provisions of a contract. Users are responsible for its correct application.

#### **Compliance with a British Standard cannot confer immunity from legal obligations.**

Particular attention is drawn to the following specific regulations:

- Consumer Protection Act 1987 [1];
- Batteries and Accumulators (Containing Dangerous Substances) (Amendment) Regulations 2001 [2];
- Electrical Equipment (Safety) Regulations 1994 [3].

## Introduction

Fire and carbon monoxide alarms for use in dwellings have been available for many years, and are specified in BS EN 14604 (smoke alarms), BS 5446-2 (heat alarms) and BS EN 50291-1 (carbon monoxide alarms). These devices are intended to warn of the presence of a potentially dangerous condition by emitting a loud piercing sound. However, people with hearing loss might not be able to adequately hear such an alarm sound.

There are recognized methods of alerting deaf and hard of hearing people, including the use of vibratory, visual alarm and low frequency audible devices. To provide a fire or carbon monoxide warning for those who are deaf or hard of hearing, it has become common practice for such devices to be coupled to domestic alarms. For example, vibrating pads can be used to awaken deaf or hard of hearing people, and visual alarms to alert those already awake, in the event of the associated alarm(s) activating. There is therefore an increasing need for standardization of such alarm systems. This part of BS 5446 addresses that need by specifying requirements for fire and carbon monoxide alarm systems that include fire and carbon monoxide alarms and associated warning devices used in dwellings to warn deaf and hard of hearing people. This part of BS 5446 does not claim to provide an exclusive or definitive solution to the problem of providing reliable protection to people with impaired hearing. It is recognized that other techniques or products might be developed which would currently fall outside the scope of this part of BS 5446.

This part of BS 5446 includes tests and requirements for vibratory, visual alarm and low frequency audible devices, for fire and/or carbon monoxide alarms by reference to BS EN 14604, BS 5446-2 and BS EN 50291-1, and for the interconnections of these components. The tests specified in this part of BS 5446 are type tests and are not intended as manufacturers' tests to maintain uniformity of quality in production, which is dealt with in the BS EN ISO 9000 series. While the tests are intended to assess the most important features of the design and construction of the components of alarm systems for deaf and hard of hearing people, they cannot remove the necessity for regular inspection and maintenance, which is essential for reliable operation.

The sound from fire and carbon monoxide alarms is intended to alert people when they are either awake or asleep, but for a person with significant hearing loss, a combination of vibration, flashing light and sound is generally required in order to provide an equivalent level of protection. Some medical conditions might require specialist medical advice as to appropriate alarm equipment.

Since any fire or carbon monoxide alarm that forms part of a system for deaf and hard of hearing people is required to conform to BS EN 14604, BS 5446-2 or BS EN 50291-1, it will incorporate a functioning sounder. BS 5446-3 specifies requirements for the additional vibration and flashing light functions and any low frequency sounders.

To assist in the selection of an alarm system appropriate to an individual's needs, a grade system has been devised for guidance purposes. The grade system is covered in more detail in the Commentary on Clause 4 and Annex A.

## 1 Scope

This part of BS 5446 specifies requirements and test methods for components and their means of interconnection (e.g. by electrical wiring or by radio links) intended to be assembled to create fire and/or carbon monoxide alarm systems for deaf and hard of hearing people, for the purpose of life safety in dwellings.

*NOTE 1 Although this part of BS 5446 provides the specification for alarm systems for dwellings, it is recognized that these systems, or components thereof, might be used in other situations, where similar requirements could be anticipated.*

*NOTE 2 Equipment conforming to this part of BS 5446 might not be suitable for use in boats, due to the corrosive atmosphere. It might however be suitable for use in other leisure accommodation vehicles (LAVs).*

*NOTE 3 The systems specified in this part of BS 5446 are specifically intended to give warning in the event of fire, or carbon monoxide emissions. However, it is recognized that systems might also incorporate devices to alert deaf and hard of hearing people to other events, such as door bell, telephone, alarm clock, baby alarm, etc., that are outside the scope of this part of BS 5446.*

This part of BS 5446 does not cover medical vibrating devices as defined in BS EN ISO 9999; these are covered by BS EN 12182.

## 2 Normative references

The following documents, in whole or in part, are normatively referenced in this document and are indispensable for its application. For dated references, only the edition cited applies. For undated references, the latest edition of the referenced document (including any amendments) applies.

BS 5446-2, *Fire detection and fire alarm devices for dwellings – Part 2: Specification for heat alarms*

BS 5839-6, *Fire detection and fire alarm systems for buildings – Part 6: Code of practice for the design, installation, commissioning and maintenance of fire detection and fire alarm systems in domestic premises*

BS EN 54-1, *Fire detection and fire alarm systems – Part 1: Introduction*

BS EN 54-3:2001, *Fire detection and fire alarm systems – Part 3: Fire alarm devices – Sounders*

BS EN 54-23:2010, *Fire detection and fire alarm systems – Part 23: Fire alarm devices – Visual alarm devices*

BS EN 14604, *Smoke alarm devices*

BS EN 50130-4:2011, *Alarm systems – Part 4: Electromagnetic compatibility – Product family standard – Immunity requirements for components of fire, intruder, hold up, CCTV, access control and social alarm systems*

BS EN 50291 (both parts), *Electrical apparatus for the detection of carbon monoxide in domestic premises*

BS EN 60068-2-1, *Environmental testing – Part 2-1: Tests – Test A: Cold*

BS EN 60068-2-6:2008, *Environmental testing – Part 2-6: Tests – Test Fc: Vibration (sinusoidal)*

BS EN 60068-2-27:2009, *Environmental testing – Part 2-27: Tests – Test Ea and guidance: Shock*

BS EN 60068-2-31:2008, *Environmental testing – Part 2-31: Tests – Test Ec: Rough handling shocks, primarily for equipment-type specimens*



BS EN 60068-2-42, *Environmental testing – Part 2-42: Tests – Test Kc: Sulphur dioxide test for contacts and connections*

BS EN 60068-2-75, *Environmental testing – Part 2-75: Tests – Test Eh: Hammer tests*

BS EN 60068-2-78, *Environmental testing – Part 2-78: Tests – Test Cab: Damp heat, steady state*

BS EN 60529:1992+A2:2013, *Specification for degrees of protection provided by enclosures (IP code)*

BS EN 60950-1, *Information technology equipment – Safety – Part 1: General requirements*

BS EN ISO 13943, *Fire safety – Vocabulary*

### 3 Terms and definitions

For the purposes of this part of BS 5446, the terms and definitions in BS 5446-2, BS 5839-6, BS EN 54-1, BS EN 14604, BS EN 50291, BS EN ISO 13943 and the following apply.

#### 3.1 control unit

separate self-contained unit that houses components for functions such as supply of power, monitoring of circuits, and control and indication

#### 3.2 deaf or hard of hearing person

person who, as a result of hearing loss (including total hearing loss), is unable to rely on hearing audible alarm signals under typical conditions of use from fire or carbon monoxide alarms

#### 3.3 low frequency sounder

audible device with a frequency in the range 500 Hz to 1 000 Hz

#### 3.4 primary usage plane

plane, parallel to the way a vibrating fire alarm device is normally used or operated

#### 3.5 vibrating pad

device intended for installation underneath a mattress or pillow to rouse a deaf or hard of hearing person from sleep by subjecting the person to vibrations

#### 3.6 vibrating alerter

radio-linked portable device intended to alert a deaf or hard of hearing person, while awake, by subjecting the person to vibrations

#### 3.7 vibrating alarm device

device that provides a tactile sensation sufficient to alert the user to a fire alarm condition whether asleep or awake

*NOTE* Vibrating fire alarm devices may be fixed, movable or portable.

- *Fixed equipment is equipment fastened to a support or otherwise secured in a specific location, or equipment not provided with a carrying handle and having such a mass that it cannot easily be moved (e.g. a fire alarm system control panel screwed to the wall).*
- *Moveable equipment is equipment which is not fixed equipment and which is not normally in operation while the location is changed (e.g. a local unit or controller which is placed on a Table top and operates a vibrating pad in a bed).*

- *Portable equipment is equipment designed to be in operation while being carried (e.g. radio pager or other system using radio communication).*

### 3.8 visual alarm device

device which generates a flashing light to signal to the user that an alarm condition exists

## 4 General requirements for alarm systems

### COMMENTARY ON CLAUSE 4

*An alarm system comprises one or more detectors and one or more actuators from the following list, together with additional items as appropriate:*

- a) *detectors:*
  - 1) *smoke alarm (6.1.1);*
  - 2) *heat alarm (6.1.2) [interconnected to smoke alarm(s) on the escape route];*
  - 3) *carbon monoxide alarm (6.1.3);*
- b) *actuators:*
  - 1) *control unit (6.2), which may be a self-contained unit or may be made up of several parts, each of which may be integrated with another component of the system;*
  - 2) *visual alarm device (6.3);*
  - 3) *vibrating pad (6.4);*
  - 4) *vibrating alerter (6.5);*
  - 5) *low frequency sounder (6.6);*
- c) *additional items:*
  - 1) *power supply, which may be self-contained or may form a part or parts of other system components, e.g. control unit and smoke alarm (specific requirements for power supplies for control units are given in 6.2);*
  - 2) *appropriate interconnecting cables (Clause 5);*
  - 3) *set of instructions for creating a system from these components, and for operation of the system (Clause 8).*

*Individual components may be combined to form different grades of systems which are graded according to the minimum items needed to alert a deaf or hard of hearing person, while asleep or awake. The grading system is given in Annex A.*

*It is strongly recommended that a fire or carbon monoxide alarm signal has priority over the signal from any other device that might be incorporated into the system.*

When a vibrating alerter is included in the system, the associated radio transmission equipment (6.5 and 6.7) shall be supplied.

For any other radio-linked components, radio transmitter and receiver units shall be supplied as required (6.7).

**NOTE 1** *Specific requirements for power supplies for radio-linked systems are given in 6.7.6.*

**NOTE 2** *For those who are unable to hear audible alarm signals even with the use of a hearing aid or cochlear implant, it might be necessary to provide additional visual alarm devices (6.3) and/or vibrating alarm devices (6.4 and 6.5).*

## 5 Constructional and electrical requirements

### 5.1 Electrical safety

All components of a system, including flexible mains supply cord/cable, shall conform to the appropriate requirements of BS EN 60950-1.

*NOTE 1 Fixing holes in a component should be positioned where they are easily accessible and such that damage will not be caused to internal parts when tightening/loosening fixing screws.*

*NOTE 2 No part of the system should be held in position by, or rely on support from, any attached interconnecting wiring.*

### 5.2 Component interconnections

When tested in accordance with the appropriate cable product standard, cables for interconnecting components shall meet the minimum requirements specified in the appropriate cable product standard for the relevant currents and voltages.

Connecting arrangements for fire and carbon monoxide alarms shall be in accordance with BS EN 14604, BS 5446-2 or BS EN 50291 as appropriate. Every other connection between system components shall be via a mechanically latching connector that cannot be incorrectly connected.

*NOTE Wired components may be powered via other components. All components should require clear and deliberate action by users to disable them.*

### 5.3 Connecting terminals

Terminals shall hold conductors by means of screws, nuts or other equally effective means.

Terminals shall allow the connection of conductors having a nominal cross-sectional area in the range 0.4 mm<sup>2</sup> to 1.5 mm<sup>2</sup>.

*NOTE 1 Terminals for connection of external cables and wires should be easily accessible and clearly marked.*

*NOTE 2 Each terminal should be so designed that it clamps the conductor between metal surfaces without rotation of those surfaces, but with sufficient contact pressure, and without damage to the conductor.*

### 5.4 Battery connectors

Battery connectors for flexible leads shall be protected by strain-relieving devices conforming to the requirements for battery connections specified in BS EN 14604.

### 5.5 Electromagnetic compatibility

Each component shall conform to the appropriate requirements specified in BS EN 50130-4:2011, Clause 8, Clause 9, Clause 10, Clause 11, Clause 12 and Clause 13.

### 5.6 Power supplies

#### 5.6.1 General

Any control unit, low frequency sounder, vibrating pad or visual alarm device may be powered:

- a) from a 230 V a.c. mains supply (see 5.6.2), in which case a standby supply conforming to 5.6.3 shall be provided; or

- b) from a primary battery supply (see 5.6.4), for which a standby supply may be provided. If a standby supply is provided it shall conform to 5.6.5.

The mains connecting cable supplying power to the component shall be either permanently wired into the component or provided with a means of securing the cable to the component to prevent accidental disconnection.

Power supplies shall be marked in accordance with Clause 7.

### 5.6.2 Mains power supply

The connection to the mains power supply shall comprise a plug suitable for connection to a standard domestic 13A socket (or a mains adaptor if the supply to the system is at a lower voltage than 230 V a.c.). The plug/adaptor shall be marked with white lettering on a red background with the text "Alarm system – DO NOT REMOVE OR SWITCH OFF".

When tested in accordance with Annex B, the mains power supply shall be capable of supplying all the power for the system, with the standby power supply (battery) disconnected for 72 h, followed by 4 min in alarm condition, or, in the absence of an alarm condition, a fault warning in accordance with 6.2.6.1f) for at least 24 h.

### 5.6.3 Standby power supply for mains-powered units

*NOTE* The standby battery should be of a type that has an expected life of at least 4 years under the conditions likely to be experienced in normal use. Information should be provided to indicate the period beyond which they should be replaced.

When tested in accordance with Annex B, the standby power supply shall be capable of supplying all the power for the system with the mains supply disconnected for a period of at least 72 h, followed by 4 min in alarm condition.

When tested in accordance with Annex B, the battery voltage at the end of the 4 min in alarm condition shall be greater than or equal to the minimum battery voltage specified by the battery manufacturer.

### 5.6.4 Primary battery power supply

Any control box, sounder or visual alarm device may be powered by primary batteries provided the following requirements are met.

- a) The battery or batteries shall be capable of supplying the quiescent load of the device together with the additional load resulting from a routine weekly 10 s test for at least 1 year or the duration specified by the manufacturer, whichever is longer, before the battery fault warning is given.
- b) At the point when the battery fault warning commences, the battery or batteries shall have sufficient capacity to give an alarm condition when tested in accordance with Annex B for at least 4 min in the event of activation by a fire or carbon monoxide alarm, or, in the absence of an alarm condition, a battery fault warning for at least 30 days.
- c) If the system relies upon a radio frequency signal for communication between the smoke or carbon monoxide alarm and the control box, sounder or visual alarm device, the requirements at a) and b) shall also be met for any battery or batteries solely used to power the radio frequency signal at the control box, sounder and visual alarm device.

*NOTE* As it is not practicable to run a system and battery combination for a real-time test period of 1 year, the test house may accept data detailing the control box, sounder, visual alarm device loads and the battery characteristics to determine whether the requirements can be met. The load calculations should be undertaken for the maximum number of devices that can be connected together in any one system.

### 5.6.5 Standby power supply for battery-powered units

If a standby battery power supply is provided, it shall conform to the following requirements.

- a) The standby battery shall be of a type that has an expected life of at least 4 years. The manufacturer shall supply data to confirm this expectation.
- b) When tested in accordance with Annex B, the standby power supply shall be capable of supplying all the power for the system with the primary battery source disconnected for the period of at least 72 h, followed by 4 min in the alarm condition.
- c) When tested in accordance with Annex B, the standby battery voltage at the end of the 4 min in alarm condition shall be greater than or equal to the minimum specified battery voltage [see Annex C, C.4.2d)].
- d) Batteries shall be identified by some means as to which are the primary and secondary supplies.

### 5.7 Operation

When a fire or carbon monoxide alarm condition is triggered:

- a) the alarm outputs shall be given within 3 s on the sensing device and within 30 s on all interconnected devices;
- b) the alarm outputs shall continue until the alarm condition ceases.

### 5.8 Integrity

If a component is fitted with an off switch, or a switch to disable the alarm signal, the design of the switch shall be such as to avoid inadvertent operation.

The off switch may be a physical device or an option, selected from a menu.

- a) A physical switch shall be of a type and location such that two separate operations are necessary to operate it.
- b) A menu-selectable switch shall not be located on the component's main menu and shall require two distinct menu selections in order to operate it.

## 6 Requirements for components

*NOTE* The components of a system should be suitable for use indoors in a domestic environment.

### 6.1 Alarms

#### 6.1.1 Smoke alarms

Smoke alarms shall conform to BS EN 14604 and to any additional requirements specified in this part of BS 5446.

*NOTE* Additional requirements given in this part of BS 5446 include requirements for connections and monitoring that are not needed for standard smoke alarms.

Every smoke alarm forming part of a system shall be provided with the information specified in Clause 8.

### 6.1.2 Heat alarms

Heat alarms forming part of a system shall conform to BS 5446-2 and to any additional requirements specified in this part of BS 5446.

*NOTE Additional requirements given in this part of BS 5446 include requirements for connections and monitoring that are not needed for standard heat alarms.*

Heat alarms forming part of a system shall be provided with the information specified in Clause 8.

### 6.1.3 Carbon monoxide alarms

Carbon monoxide alarms forming part of a system shall conform to BS EN 50291-1 and to any additional requirements specified in this part of BS 5446.

*NOTE Additional requirements given in this part of BS 5446 include requirements for connections and monitoring that are not needed for standard carbon monoxide alarms.*

Carbon monoxide alarms forming part of a system shall be provided with the information specified in Clause 8.

## 6.2 Control and indicating functions

### 6.2.1 General

*NOTE When the control and indicating functions are contained within a separate self-contained unit, this is defined as a control unit (see 3.1). Alternatively, the control and indicating functions may be combined with another component, or may have its functions spread over more than one component of the system.*

When a control unit is tested in accordance with the general procedures specified in Annex C it shall meet the requirements specified in 6.2.2 to 6.2.6. When a control unit is tested in accordance with the general procedures specified in Annex C and the appropriate method specified in Annex D, in accordance with the test schedule given in D.1, it shall meet the requirements specified in 6.2.7.1a).

Control units shall be marked in accordance with Clause 7 and shall be provided with the information specified in Clause 8.

Devices, other than control units, that incorporate control and indicating functions, shall meet the general requirements specified in 6.2.2 to 6.2.6 and the appropriate component-specific requirements specified in 6.2.7.1b) to 6.2.7.1e).

For all devices the mandatory indicators shall be visible from a distance of 3 m from the mounting surface of the device, in an ambient light intensity up to 500 lx.

### 6.2.2 Fire alarm indicator

There shall be a dedicated red light emitting fire alarm indicator.

When the fire alarm is tested by pressing the test button, when a fire alarm signal is received, the light shall either be on continuously or pulsing at a minimum rate of 1 Hz, and no fault indication shall be given.

### 6.2.3 Carbon monoxide alarm indicator

There shall be a dedicated red light emitting carbon monoxide alarm indicator.

When the carbon monoxide alarm is tested by pressing the test button, when a carbon monoxide alarm signal is received, the light shall either be on continuously or pulsing at a minimum rate of 1 Hz, and no fault indication shall be given.

## 6.2.4 Power supply indicators

### 6.2.4.1 Mains power supply indicator

Any device intended to be connected to the a.c. mains (or transformed to d.c. from the mains supply) shall be provided with a continuous mains-on indicator to indicate that the device is receiving power. The indicator shall be green and clearly labelled to distinguish it from any other indications that might be provided (see 6.2.5).

### 6.2.4.2 Battery power supply indicator

Any device intended to be solely powered from a primary battery supply shall be provided with a power-on indicator to indicate that the device is receiving a power supply. The indicator shall be green and clearly labelled to distinguish it from any other indications that might be provided (see 6.2.5). The indicator shall either be on continuously or shall pulse at least once every 30 s.

## 6.2.5 Additional indicators

Additional indicators shall not be coloured red or green.

Indicators used to indicate faults shall be coloured amber or yellow.

## 6.2.6 Indications of faults in the system

**6.2.6.1** When system components are tested as follows, a visual indication shall be given within 300 s by illuminating an amber or yellow light either continuously or at a flash rate of not less than 0.2 Hz:

- a) short circuit in a connection between a control unit and each externally hardwired connected alarm device;
- b) open circuit in a connection between a control unit and each externally hardwired connected alarm device;
- c) short circuit between a control unit and a hardwired smoke alarm or carbon monoxide alarm;
- d) open circuit between a control unit and a hardwired smoke alarm or carbon monoxide alarm;
- e) low battery condition of the smoke alarm or carbon monoxide alarm;  
*NOTE 1 The low battery condition can be indicated by an amber or yellow light flashing on the carbon monoxide alarm or the smoke alarm. On smoke alarms without an amber light the low battery can be indicated with a unique red LED slow flash pattern once a minute and/or when the test button is pressed*
- f) failure or disconnection of a standby supply to any part of the system other than a remote alerter;
- g) when the system is radio-linked and uses one or more primary batteries as a power supply, the low power condition of that supply.

Failure or disconnection of the primary mains supply shall result in the green light turning off.

Failure or disconnection of a unit powered by a primary battery shall result in the extinguishment of the periodic power light flash.

*NOTE 2 This is not applicable to a remote alerter.*



**6.2.6.2** When tested in accordance with Annex E, **E.4**, the integrity of the radio link between the radio-linked alarm devices shall meet the following requirements.

- a) For mains-powered devices, the amber fault light shall indicate a fault within 4 h.
- b) For primary battery-powered devices, the fault shall be indicated within 12 h.

## **6.2.7 Environmental requirements**

### **6.2.7.1 General**

Devices that incorporate control and indicating functions shall meet the following requirements.

- a) Control units shall conform to the requirements specified in **6.2.7.2** to **6.2.7.6**.
- b) Devices, other than control units, incorporating a visual alarm device shall conform to the requirements specified in **6.3.5.1** to **6.3.5.8**.
- c) Devices, other than control units, incorporating a vibrating pad shall conform to the requirements specified in **6.4.5.1** to **6.4.5.8**.
- d) Devices, other than control units, incorporating a vibrating alerter shall conform to the requirements specified in **6.5.8.1** to **6.5.8.9**.
- e) Devices, other than control units, incorporating a low frequency sounder shall conform to the requirements specified in **6.6.5.1** to **6.6.5.8**.

### **6.2.7.2 Resistance to damp heat**

When the control unit is tested in accordance with **D.2**:

- a) when the functional testing is carried out during the last 30 min of conditioning (**D.2.3**), a visual indication of power supply shall be given as specified in **6.2.4** upon connection of the control unit, and a visual indication of alarm shall be given as specified in **6.2.2** or **6.2.3** as appropriate upon triggering of the alarm condition;
- b) when the functional testing is carried out after the recovery period (**D.2.4**):
  - 1) a visual indication of power supply shall be given as specified in **6.2.4** upon connection of the control unit;
  - 2) a visual indication of alarm shall be given as specified in **6.2.2** upon triggering of a fire alarm condition;
  - 3) a visual indication of alarm shall be given as specified in **6.2.3** upon triggering of a carbon monoxide condition.

### **6.2.7.3 Resistance to cold**

When the control unit is tested in accordance with **D.3**:

- a) when the functional test (**6.2.6.1**) is performed during the last 30 min of conditioning (**D.3.3**), a visual indication of power supply shall be given as specified in **6.2.4** upon connection of the control unit, and a visual indication of alarm shall be given as specified in **6.2.2** or **6.2.3** as appropriate upon triggering of the alarm condition;
- b) when the functional test (**6.2.6.1**) is performed after the recovery period (**D.3.4**), visual indications of power supply and alarm condition shall be given as specified in **6.2.7.2b**).



#### 6.2.7.4 Resistance to corrosion

When the control unit is tested in accordance with **D.4**, when the functional test (6.2.6.1) is performed after the recovery period (**D.4.2**), visual indications of power supply and alarm condition shall be given as specified in 6.2.7.2b).

#### 6.2.7.5 Resistance to impact

*NOTE This requirement is applicable only to control units that are intended for mounting on walls.*

When the control unit is tested in accordance with **D.5**, visual indications of power supply and alarm condition shall be given as specified in 6.2.7.2b).

#### 6.2.7.6 Resistance to dropping

*NOTE This requirement is applicable only to control units that are intended to be free-standing (e.g. on a bedside table).*

When the control unit is tested in accordance with **D.6**, visual indications of power supply and alarm condition shall be given as specified in 6.2.7.2b).

### 6.3 Visual alarm device

#### 6.3.1 General

*NOTE Examples of typical visual alarm devices include:*

- flashing xenon beacon;
- continuously powered incandescent lamp with a rotating reflector;
- incandescent lamp powered to flash on and off;
- ultra-bright LED array.

*A visual alarm device (see 3.8) may form an integral part of one of the elements of the alarm system, e.g. a control box or receiver unit, or it may be a completely separate device connected only by cables, or by a radio signal, to other elements of the alarm system.*

When the visual alarm device is tested in accordance with the general procedures specified in Annex C and the appropriate methods specified in 6.3.2 to 6.3.5 and in accordance with the test schedule given in Annex F, **F.1**, visual alarm devices shall meet the requirements specified in 6.3.2 to 6.3.5.

Visual alarm devices shall be marked in accordance with Clause 7 and shall be provided with the information specified in Clause 8.

#### 6.3.2 Colour and coverage volume

##### 6.3.2.1 Colour

The flashing light from the visual alarm device shall be either white or red.

##### 6.3.2.2 Coverage volume

When tested in accordance with BS EN 54-23:2010, **4.3.1** and **5.3.1**, the visual alarm device shall meet the minimum coverage volume of either C-3-4 or W-2.4-1.8, or a larger coverage volume if specified by the manufacturer. An ambient light level in the range 300 lx to 400 lx shall be assumed.

The visual alarm device shall meet a minimum illumination of 0.4 lx on surfaces perpendicular to the direction of the light emitted from the device at the edges of the coverage volume.

*NOTE* The measured light intensity of the device is used to define the effective space or coverage volume. This minimum level is such that adequate visual warning will be given on any surface within the coverage volume, so that the device does not necessarily have to be directly within the field of view of the recipient for it to be effective.

#### **6.3.2.3 Variation in light output**

When tested in accordance with BS EN 54-23:2010, 4.3.2 and 5.3.2, the visual alarm device shall meet the requirements specified therein.

#### **6.3.2.4 Minimum and maximum effective luminous intensity**

When tested in accordance with BS EN 54-23:2010, 4.3.3 and 5.3.3, the visual alarm device shall meet the requirements specified therein.

#### **6.3.2.5 Light temporal pattern and frequency of flashing**

When tested in accordance with BS EN 54-23:2010, 4.3.5 and 5.3.5, the visual alarm device shall meet the requirements specified therein.

### **6.3.3 Reproducibility**

When all samples are tested in accordance with BS EN 54-23:2010, 5.1.7, the visual alarm devices shall meet the requirements specified therein.

### **6.3.4 Duration of operation**

When tested in accordance with BS EN 54-23:2010, 5.2.1, the visual alarm device shall meet the requirements specified therein.

### **6.3.5 Environmental requirements**

#### **6.3.5.1 Resistance to dry heat**

When tested in accordance with BS EN 54-23:2010, 5.4.1.1, using the number of the specimen specified in Table F.1 of the present standard, the visual alarm device shall meet the requirements specified in BS EN 54-23:2010, 5.4.1.1 for a Type A device.

#### **6.3.5.2 Resistance to dropping**

*NOTE* This requirement is applicable only to visual alarm devices that are intended to be free-standing, (e.g. on a bedside Table).

When tested in accordance with F.2, the visual alarm device shall be deemed to have passed the test if:

- a) no false alarm operation or fault signal are detected during and after the conditioning; and
- b) all light sources and indicators are functioning when checked; and
- c) the ratio of the light output levels  $Q_{\max}$  and  $Q_{\min}$  does not exceed 1.5; and
- d) there is no physical damage to the device.

#### **6.3.5.3 Resistance to cold**

When tested in accordance with BS EN 54-23:2010, 5.4.1.3, using the number of the specimen specified in Table F.1 of the present standard, the visual alarm device shall meet the requirements specified in BS EN 54-23:2010, 5.4.1.3 for a Type A device.

#### 6.3.5.4 Resistance to damp heat (steady state)

When tested in accordance with BS EN 54-23:2010, 5.4.2.2, except that the duration shall be 4 days, using the number of the specimen specified in Table F.1 of the present standard, the visual alarm device shall meet the requirements specified in BS EN 54-23:2010, 5.4.2.2.

#### 6.3.5.5 Resistance to corrosion

When tested in accordance with BS EN 54-23:2010, 5.4.4, except that the duration shall be 4 days, using the number of the specimen specified in Table F.1 of the present standard, the visual alarm device shall meet the requirements specified in BS EN 54-23:2010, 5.4.4.

#### 6.3.5.6 Resistance to impact

When tested in accordance with BS EN 54-23:2010, 5.4.3.2, using the number of the specimen specified in Table F.1 of the present standard, the visual alarm device shall meet the requirements specified in BS EN 54-23:2010, 5.4.3.2.

*NOTE This applies to both wall-mounted and ceiling-mounted devices.*

#### 6.3.5.7 Resistance to vibration, sinusoidal (operational)

When tested in accordance with BS EN 54-23:2010, 5.4.3.3, using the number of the specimen specified in Table F.1 of the present standard, the visual alarm device shall meet the requirements specified in BS EN 54-23:2010, 5.4.3.3.

#### 6.3.5.8 Resistance to shock (operational)

When tested in accordance with BS EN 54-23:2010, 5.4.3.1, using the number of the specimen specified in Table F.1 of the present standard, the visual alarm device shall meet the requirements specified in BS EN 54-23:2010, 5.4.3.1.

### 6.4 Vibrating pad

#### 6.4.1 General

*NOTE Vibrating pads should be designed to be located under the mattress or pillow of a bed. The purpose of a vibrating pad is that, when energized, it vibrates with sufficient intensity to rouse a deaf or hard of hearing person. It is desirable that a means be provided to prevent the vibrating pad from slipping out of position, particularly if it is located under the pillow.*

When tested in accordance with the general procedures specified in Annex C and the appropriate method specified in Annex G, in accordance with the test schedule given in G.1, vibrating pads shall meet the requirements specified in 6.4.2 to 6.4.5.

Vibrating pads shall be marked in accordance with Clause 7 and shall be provided with the information specified in Clause 8.

If the vibrating pad incorporates a radio link, the system shall conform to the additional requirements specified in 6.7.

#### 6.4.2 Vibration frequency, pulse pattern and vibration intensity

When tested in accordance with the general procedures specified in Annex C and the method specified in G.2:

- a) the vibrating pad shall vibrate at a frequency within the range 25 Hz to 150 Hz;
- b) the vibrating pad shall operate with a pulse pattern having an "on" period of  $(2 \pm 1)$  s, and an "off" period of  $(2 \pm 1.5)$  s after a delay of not more than 5 s;

- c) the vibrating pad shall produce a minimum peak-to-peak acceleration of not less than 4 g in a direction perpendicular to the primary usage plane with a 100 g load, i.e. with the mass of the vibration apparatus support plate normalized to 100 g;
- d) the vibrating pad shall produce a peak acceleration of not less than 15% of the value measured in c) in a direction parallel to the primary usage plane; and
- e) the vibrating pad shall produce a maximum peak acceleration of not greater than 15% of the value measured in c) throughout a continuous period of not less than 1.0 s during each "off" cycle at the measuring point specified in Annex G.

#### 6.4.3 Reproducibility

When measured in accordance with G.3, the vibrating pad shall meet the requirement specified in 6.4.2c), and the ratio of  $a_{n,max}$  to  $a_{n,min}$  shall be less than 2.

#### 6.4.4 Durability

When tested in accordance with G.4, when the alarm condition is triggered, the vibrating pad shall meet the requirements specified in 6.4.2, and the ratio of  $a_{n,max}$  to  $a_{n,min}$  shall be less than 1.5 for each set of measurements.

#### 6.4.5 Environmental requirements

##### 6.4.5.1 Resistance to dry heat

When tested in accordance with G.5, when the alarm condition is triggered, the vibrating pad shall meet the requirements specified in 6.4.2, and the ratio of  $a_{n,max}$  to  $a_{n,min}$  shall be less than 1.5 for each set of measurements.

##### 6.4.5.2 Resistance to cold

When tested in accordance with G.6, when the alarm condition is triggered, the vibrating pad shall meet the requirements specified in 6.4.2, and the ratio of  $a_{n,max}$  to  $a_{n,min}$  shall be less than 1.5 for each set of measurements.

##### 6.4.5.3 Resistance to damp heat

When tested in accordance with G.7, when the alarm condition is triggered, the vibrating pad shall meet the requirements specified in 6.4.2, and the ratio of  $a_{n,max}$  to  $a_{n,min}$  shall be less than 1.5 for each set of measurements.

##### 6.4.5.4 Resistance to corrosion

When tested in accordance with G.8, when the alarm condition is triggered, the vibrating pad shall meet the requirements specified in 6.4.2, and the ratio of  $a_{n,max}$  to  $a_{n,min}$  shall be less than 1.5 for each set of measurements.

##### 6.4.5.5 Resistance to impact

When tested in accordance with G.9, when the alarm condition is triggered, the vibrating pad shall meet the requirements specified in 6.4.2, and the ratio of  $a_{n,max}$  to  $a_{n,min}$  shall be less than 1.5 for each set of measurements.

##### 6.4.5.6 Resistance to vibration – external (endurance)

When tested in accordance with G.10, when the alarm condition is triggered, the vibrating pad shall meet the requirements specified in 6.4.2, and the ratio of  $a_{n,max}$  to  $a_{n,min}$  shall be less than 1.5 for each set of measurements.

#### 6.4.5.7 Resistance to shock

When tested in accordance with **G.11**, when the alarm condition is triggered:

- a) no false operation or fault signals shall be detected during the conditioning period plus a further 2 min; and
- b) the vibrating pad shall function in accordance with **6.4.2** when checked during final measurements; and
- c) the ratio of  $a_{n,max}$  to  $a_{n,min}$  shall be less than 1.5 for each set of measurements.

#### 6.4.5.8 Resistance to dropping

When tested in accordance with **G.12**, when the alarm condition is triggered, the vibrating pad shall meet the requirements specified in **6.4.2** and the ratio of  $a_{n,max}$  to  $a_{n,min}$  shall be less than 1.5 for each set of measurements.

### 6.5 Vibrating alerter

*NOTE* Vibrating alerters may also act as vibrating pads when not being worn, provided that they meet the vibration requirements for vibrating pads (**6.4**) as well as those for alerters.

#### 6.5.1 General

*NOTE* Examples of typical principles of operation for vibrating alerters include:

- electric motor and mechanical cam/eccentric;
- solenoid or other coil/armature arrangement;
- solid state device.

Vibrating alerters shall include both a vibrating function and a light-emitting indicator.

When tested in accordance with the general procedures specified in Annex C and the appropriate method specified in Annex H, in accordance with the test schedule given in **H.1**, vibrating alerters shall meet the requirements specified in **6.5.2** to **6.5.8**.

Vibrating alerters shall be marked in accordance with Clause **7** and shall be provided with the information specified in Clause **8**.

The radio link for vibrating alerters shall conform to the additional requirements specified in **6.7**.

#### 6.5.2 Vibration frequency, pulse pattern and vibration intensity

When tested in accordance with Annex C and the method specified in **H.2**:

- a) the vibrating alerter shall vibrate at a frequency within the range 25 Hz to 150 Hz;
- b) the vibrating alerter shall operate with a pulse pattern having an "on" period of  $(2 \pm 1)$  s, and an "off" period of  $(2 \pm 1.5)$  s after a delay of not more than 5 s;
- c) the vibrating alerter shall produce a minimum peak-to-peak acceleration of 1.0 g normal to the primary usage plane throughout a continuous period of not less than 1.0 s during each "on" cycle at the measuring point (accelerometer location) specified in Annex H;
- d) the vibrating alerter shall produce a minimum peak acceleration of not less than 15% of the value measured in c) parallel to the primary usage plane; and

- e) the vibrating alerter shall produce a maximum peak acceleration of not greater than 15% of the value measured in c) throughout a continuous period of not less than 1.0 s during each “off” cycle at the measuring point specified in Annex H.

*NOTE* Where the vibrating alerter is used for other purposes (e.g. general paging), the recipient should, by means of the pulse pattern, be able to tell the difference between a signal of fire and a signal for non-emergency purposes.

### 6.5.3 Light-emitting indicators

During the period when an alarm radio signal is received by the vibrating alerter, the visual indicator shall operate continuously or shall pulse on and off in synchronism with the pulse pattern of the vibrating mechanism, to indicate a fire. If the vibrating alerter is designed to indicate both fire and/or carbon monoxide conditions, separate alarm indicators shall be provided.

The light-emitting indicator(s) shall be red in colour, and shall be visible in an ambient light intensity up to 500 lx, at any angle up to 22.5° from a line through the indicator perpendicular to its mounting surface, at 0.8 m distance.

No other light-emitting indicator on the vibrating alerter shall be red in colour.

Where the vibrating alerter is used for other purposes (e.g. general paging), the indication for non-emergency purposes shall be different from that for emergency purposes.

If the light emitting indicators are on a display screen, the red indicators shall clearly indicate that they are for fire or carbon monoxide such that they cannot be confused with any other red areas on the display screen.

### 6.5.4 Integrity

In addition to the requirements specified in 5.8, if the vibrating alerter is fitted with an off switch, or a switch to disable the vibrate function, the design of the switch shall be such as to avoid inadvertent operation [see 5.8a) and 5.8b)].

### 6.5.5 Operation

When an alarm condition is simulated:

- a) the alarm shall be given at the vibrating alerter within 5 s without the need to acknowledge or reset any other signal;
- b) the alarm given at the vibrating alerter shall continue while the alarm signal is transmitted by the control unit, and for at least a further 60 s after cessation of the alarm signal unless a specific alarm cancel signal has been received from the control unit;

*NOTE* This ensures that the alarm at the alerter is continuous even if the control unit transmits the alarm signal repeatedly at intervals up to 10 s.

- c) if the vibrating alerter has an “acknowledge” (alarm cancel) control that can cancel the vibrating alerter alarm, and that control is operated during an alarm situation, the vibrating alerter alarm shall be automatically reinstated within 15 s of that operation unless the control unit has ceased to transmit an alarm signal.

### 6.5.6 Reproducibility

When measured in accordance with H.3, the vibrating alerter shall meet the requirement specified in 6.5.2c), and the ratio of  $a_{n,max}$  to  $a_{n,min}$  shall be less than 2.

### 6.5.7 Durability

When tested in accordance with H.4, when the alarm condition is triggered, the vibrating alerter shall meet the requirements specified in 6.5.2, and the ratio of  $a_{n,max}$  to  $a_{n,min}$  shall be less than 1.5 for each set of measurements.

### 6.5.8 Environmental requirements

#### 6.5.8.1 Resistance to dry heat

When tested in accordance with H.5, when the alarm condition is triggered, the vibrating alerter shall meet the requirements specified in 6.5.2, and the ratio of  $a_{n,max}$  to  $a_{n,min}$  shall be less than 1.5 for each set of measurements.

#### 6.5.8.2 Resistance to cold

When tested in accordance with H.6, when the alarm condition is triggered, the vibrating alerter shall meet the requirements specified in 6.5.2, and the ratio of  $a_{n,max}$  to  $a_{n,min}$  shall be less than 1.5 for each set of measurements.

#### 6.5.8.3 Resistance to damp heat

When tested in accordance with H.7, when the alarm condition is triggered, the vibrating alerter shall meet the requirements specified in 6.5.2, and the ratio of  $a_{n,max}$  to  $a_{n,min}$  shall be less than 1.5 for each set of measurements.

#### 6.5.8.4 Resistance to corrosion

When tested in accordance with H.8, when the alarm condition is triggered, the vibrating alerter shall meet the requirements specified in 6.5.2, and the ratio of  $a_{n,max}$  to  $a_{n,min}$  shall be less than 1.5 for each set of measurements.

#### 6.5.8.5 Resistance to impact

When tested in accordance with H.9, when the alarm condition is triggered, the vibrating alerter shall meet the requirements specified in 6.5.2, and the ratio of  $a_{n,max}$  to  $a_{n,min}$  shall be less than 1.5 for each set of measurements.

#### 6.5.8.6 Resistance to vibration – external (endurance)

When tested in accordance with H.10, when the alarm condition is triggered, the vibrating alerter shall meet the requirements specified in 6.5.2, and the ratio of  $a_{n,max}$  to  $a_{n,min}$  shall be less than 1.5 for each set of measurements.

#### 6.5.8.7 Resistance to shock

When tested in accordance with H.11, when the alarm condition is triggered:

- a) no false operation or fault signals shall be detected during the conditioning period plus a further 2 min; and
- b) the vibrating alerter shall function in accordance with 6.5.2 when checked during final measurements; and
- c) the ratio of  $a_{n,max}$  to  $a_{n,min}$  shall be less than 1.5 for each set of measurements.

#### 6.5.8.8 Resistance to dropping

When tested in accordance with H.12, when the alarm condition is triggered, the vibrating alerter shall meet the requirements specified in 6.5.2, and the ratio of  $a_{n,max}$  to  $a_{n,min}$  shall be less than 1.5 for each set of measurements.

#### 6.5.8.9 Resistance to liquid ingress

The vibrating alerter shall meet at least classification IP3X in accordance with BS EN 60529:1992+A2.



### 6.5.9 Power supplies

Vibrating alerters using batteries as the primary power source shall provide visual or tactile information to indicate low battery status.

Vibrating alerters shall remain operational for a minimum of 24 h from low battery indication.

## 6.6 Low frequency sounder

### 6.6.1 General

When tested in accordance with the general procedures specified in Annex C and the appropriate method specified in Annex I, in accordance with the test schedule given in I.1, low frequency sounders shall meet the requirements specified in 6.6.2 to 6.6.5.

Low frequency sounders shall be marked in accordance with Clause 7 and shall be provided with the information specified in Clause 8.

### 6.6.2 Frequency and sound pressure level

#### 6.6.2.1 Frequency

The low frequency sounder shall have the primary frequency or frequencies in the range 500 Hz to 1 000 Hz.

#### 6.6.2.2 Sound pressure level

**6.6.2.2.1** A low frequency sounder intended for general use shall produce a sound output of at least 85 dB(A) at 3 m, with a maximum sound output of 110 dB(A).

**6.6.2.2.2** A low frequency sounder intended for use in the bedroom of the person to be alerted shall produce a sound output of at least 75 dB(A) at 1 m, with a maximum sound output of 110 dB(A).

**6.6.2.2.3** When the low frequency sounder is tested in accordance with BS EN 54-3:2001, Annex C, the following requirements shall be met:

- a) For battery-powered low frequency sounders the sound output shall meet the requirements of 6.6.2.2.1 or 6.6.2.2.2, as appropriate, after 1 min of sounder operation and be not less than 3 dB(A) lower after 4 min of sounder operation.
- b) For mains-powered low frequency sounders the sound output shall meet the requirements of 6.6.2.2.1 or 6.6.2.2.2, as appropriate, after 4 min of sounder operation.

**6.6.2.2.4** For both battery operated and mains-powered low frequency sounders, the maximum sound output shall not exceed 110 dB(A) at 3 m after 1 min of sounder operation.

### 6.6.3 Reproducibility

When tested in accordance with BS EN 54-3:2001, 5.2, using the number of specimens specified in Table I.1 of the present standard, the low frequency sounder shall meet the requirements specified in BS EN 54-3:2001, 5.2.

### 6.6.4 Durability

When tested in accordance with BS EN 54-3:2001, 5.4, using the number of specimens specified in Table I.1 of the present standard, the visual alarm device shall meet the requirements specified in BS EN 54-3:2001, 5.4.



## 6.6.5 Environmental requirements

### 6.6.5.1 Resistance to dry heat

When tested in accordance with BS EN 54-3:2001, 5.5, using the number of specimens specified in Table I.1 of the present standard, the low frequency sounder shall meet the requirements specified in BS EN 54-3:2001, 5.5.

### 6.6.5.2 Resistance to cold

When tested in accordance with BS EN 54-3:2001, 5.7, using the number of specimens specified in Table I.1 of the present standard, the low frequency sounder shall meet the requirements specified in BS EN 54-3:2001, 5.7.

### 6.6.5.3 Resistance to damp heat

When tested in accordance with BS EN 54-3:2001, 5.8, except that the duration shall be reduced to 4 days, using the number of specimens specified in Table I.1 of the present standard, the low frequency sounder shall meet the requirements specified in BS EN 54-3:2001, 5.8.

### 6.6.5.4 Resistance to corrosion

When tested in accordance with BS EN 54-3:2001, 5.11, except that the duration shall be reduced to 4 days, using the number of specimens specified in Table I.1 of the present standard, the low frequency sounder shall meet the requirements specified in BS EN 54-3:2001, 5.11.

### 6.6.5.5 Resistance to impact

When tested in accordance with BS EN 54-3:2001, 5.13, using the number of specimens specified in Table I.1 of the present standard, the low frequency sounder shall meet the requirements specified in BS EN 54-3:2001, 5.13.

### 6.6.5.6 Resistance to vibration, sinusoidal (operational)

When tested in accordance with BS EN 54-3:2001, 5.14, using the number of specimens specified in Table I.1 of the present standard, the low frequency sounder shall meet the requirements specified in BS EN 54-3:2001, 5.14.

### 6.6.5.7 Resistance to shock (operational)

When tested in accordance with BS EN 54-3:2001, 5.12, using the number of specimens specified in Table I.1 of the present standard, the low frequency sounder shall meet the requirements specified in BS EN 54-3:2001, 5.12.

### 6.6.5.8 Resistance to dropping

*NOTE* This requirement is only applicable to low frequency sounders designed to be free-standing, e.g. devices that cannot be rigidly fixed to a wall or other solid surface.

When tested in accordance with I.2, the sound output of the low frequency sounder shall meet the requirements specified in 6.6.2.2.

## 6.7 Radio-linked system

### 6.7.1 General

*NOTE 1* Attention is drawn to the Radio and Telecommunication Terminal Equipment Directive 1999/5/EC [4].

*NOTE 2* Attention is drawn to the requirements of Ofcom in respect of operating frequency and maximum radio signal strength. Appropriate frequencies and duty cycles should be used in order to minimize interference with and from other systems.

When tested in accordance with the general procedures specified in Annex C and the appropriate method specified in Annex E, radio-linked systems shall meet the requirements specified in 6.7.2 to 6.7.5. Power supplies for radio-linked systems shall conform to 6.7.6.

Radio-linked systems shall be marked in accordance with Clause 7 and shall be provided with the information specified in Clause 8.

### 6.7.2 Environmental requirements

When the radio components are tested in accordance with E.1:

- a) each component shall conform to the appropriate requirements when subjected to the environmental test(s) for the equipment in which it is installed or with which it is closely associated (see E.1.1) (e.g. a transmitter unit mounted in or intended to be mounted adjacent to a smoke alarm shall conform to the environmental requirements specified in BS EN 14604, and a receiver unit mounted within a control unit shall conform to the environmental requirements specified in 6.2.7);
- b) each component shall operate correctly (i.e. an alarm signal shall be received by the receiver unit) when tested in accordance with E.1.2 and E.1.3 after being subjected to the various environmental conditions.

### 6.7.3 Operating range

When the radio components are tested in accordance with E.2, an alarm signal shall be received by the receiver unit at a distance of at least 100 m under free field conditions, or longer if specified by the manufacturer.

### 6.7.4 Fault monitoring

When the control unit and smoke alarm are tested in accordance with E.3, a fault indication, as specified in 6.2.6.2, shall be given if no transmission is received from the radio-linked smoke alarm within the time specified in 6.2.6.2 after removal of its power supply.

*NOTE The fault indication may be indicated at either the control unit or the smoke alarm.*

When the relevant components are tested in accordance with E.4, a failure of the radio transmission between the control unit and any radio-linked alarm device (e.g. a vibrating pad or vibrating alerter) shall result in a fault signal at the radio-linked alarm device of the failure, as specified in 6.2.6.2.

### 6.7.5 Vibrating alerter operation

When a radio-linked vibrating alerter is tested in accordance with E.5, when the alarm signal is acknowledged/reset (E.5.2/E.5.3), the vibrating alerter shall respond again within 15 s for each of the ten repetitions of the test.

*NOTE In a fire condition, the control unit should continue transmitting the alarm signal to a vibrating alerter until the alarm is cancelled at the control unit. If the control unit does not transmit the fire signal continuously, it is acceptable for the control unit to transmit the alarm signal repeatedly.*

### 6.7.6 Power supplies

All radio-linked mains-powered components shall be supplied from at least two independent power supplies, with the exception of smoke alarms (6.1.1), heat alarms (6.1.2), carbon monoxide alarms (6.1.3) and vibrating alerters (6.5) (see Note).

*NOTE Smoke alarms (6.1.1), heat alarms (6.1.2), carbon monoxide alarms (6.1.3) and vibrating alerters (6.5) are not required to have two power supplies but are permitted to do so.*

Vibrating devices using batteries as the principal power source shall provide visual or tactile information to indicate low battery status and shall remain operational for a minimum of 24 h from low battery indication.

When the power supply (primary and secondary power, as applicable) to one or more of the component parts of a radio linked system is disconnected, the requirements specified in 6.2.6.2a) or 6.2.6.2b), as applicable, shall be met.

## 7 Marking

### 7.1 Marking of alarm systems

The instructions for, and the packaging of, smoke alarm and/or carbon monoxide systems shall be indelibly marked with the following:

- a) the number and date of this British Standard, i.e. BS 5446-3:2015 <sup>1)</sup>;
- b) the name or trademark of the manufacturer or supplier;
- c) a list of the components of the system (see Clause 4);
- d) the name and/or type number of the system;
- e) the address of an organization capable of being responsible for servicing or repair.

### 7.2 Marking of individual components

Where practicable, each component [see 7.1c) and Clause 4] shall be indelibly marked or labelled with the following information:

- a) the number and date of this British Standard, i.e. BS 5446-3:2015 <sup>1)</sup>;
- b) the name or trademark of the manufacturer or supplier;
- c) the name and/or type number of the component;
- d) the serial number or batch number of the component;
- e) manufacturer's recommended date of product replacement;
- f) the address of an organization capable of being responsible for servicing or repair;
- g) for a visual alarm device, low frequency sounder or vibrating pad, the operating voltage of the component and the average current consumed during operation;
- h) for a vibrating alerter, the nominal voltage(s) of the internal batteries.

If a mains 13A plug is fitted to the equipment, the power supply shall be labelled in accordance with 5.6.2.

Where it is not practicable to include this information on the component, the component shall be clearly identified, e.g. by use of a reference number, and the information shall be referenced to this number in the instructions [see 8.1f)].

*NOTE* Where a visual alarm device forms part of another component of the system, e.g. a control unit, it is not necessary to provide separate marking/labelling of the integrated visual alarm device.

---

<sup>1)</sup> Marking BS 5446-3:2015 on or in relation to a product represents a manufacturer's declaration of conformity, i.e. a claim by or on behalf of the manufacturer that the product meets the requirements of the standard. The accuracy of the claim is solely the claimant's responsibility. Such a declaration is not to be confused with third-party certification of conformity.

System components incorporating user-replaceable batteries shall be marked with the battery types and reference numbers recommended by the manufacturer together with an appropriate instruction to the user: e.g. for a smoke alarm "Test the alarm for correct operation using the test facility whenever the batteries are replaced". These markings shall be visible to the user during the battery-changing operation.

Battery compartments shall also have clear markings showing the correct battery polarity.

## 8 Provision of information

### 8.1 Information to be provided with fire and carbon monoxide alarm systems

The following information shall be provided on or with fire and carbon monoxide alarm systems:

- a) whether the alarm is for fire, carbon monoxide or both;
- b) guidance as to the circumstances under which the system is to be used. In particular, it shall be explained that:
  - 1) under-mattress or under-pillow vibrators are intended for the purpose of waking sleeping persons;
  - 2) visual alarm signals are of most potential value when occupants are awake and are not intended for the purpose of waking sleeping persons;
  - 3) a low frequency sounder is most effective for waking a sleeping person when used in combination with an under-mattress or under-pillow vibrator;
- c) instructions for siting, installation, maintenance and use of each individual component, in accordance with BS 5839-6;

*NOTE* When several components are combined (see Annex A), then the instructions should also include the grade of the system, together with details of which components the system contains, the level of hearing loss that the system is intended for, and the circumstances under which the system is intended to be used (i.e. user asleep or awake).

- d) a diagram identifying the components and their interconnections;
- e) a warning that components should not be interchanged with those of different manufacture, nor should additional components be added, unless these conform to the exact types and allowable numbers specified elsewhere in the instructions. The instructions shall also state that failure to comply with this requirement might render the system unsafe;
- f) for components where it is not practicable to include the marking specified in 7.2, a key referring to the component reference numbers and giving the relevant information;
- g) instructions for mounting the visual alarm device, including cautionary guidance on any unsuitable or unsafe locations;
- h) instructions for locating the low frequency sounder, including cautionary guidance on any unsuitable or unsafe positions;
- i) instructions for locating the vibrating pad correctly in a bed, in the correct orientation, including cautionary guidance on any unsuitable or unsafe positions;

- j) for systems that include a vibrating alerter, instructions for wearing the device correctly, and cautionary guidance on the operating range of the system;
- k) where a component contains user-replaceable batteries:
  - 1) specific guidance on changing the batteries, including the types and reference numbers of the recommended batteries;
  - 2) any advice that is necessary to ensure that the batteries are properly connected;
  - 3) a recommendation that the operation of the system be tested with the test facility of the alarm whenever the batteries are replaced;
- l) where two or more alarms can be connected together as part of the system, an indication of the maximum number of alarms that can be interconnected;
- m) where a system uses radio communication between components, an instruction to the effect that, at the installation stage, the system is to be tested for normal operation throughout all the required areas of the building concerned;
- n) manufacturers' recommendations for periodic testing of the system, which should be at least monthly.

## 8.2 Information to be provided with individual components

Where a component is supplied as a discrete item (i.e. not forming part of a system), the following instructions shall be provided with the component:

- a) instructions for siting and mounting in accordance with 8.1g), 8.1h) or 8.1i) as appropriate;
- b) details of the application(s) for which the component is intended to be used, and a list of compatible equipment with which it can be used;
- c) how to connect to compatible equipment, how to test, and how the component should respond;
- d) for visual alarm devices, the average light intensity or intensity range, in candela (cd), and the minimum coverage volume.

## Annex A (informative) Alarm system grades

Individual components may be combined to form grades of system. An alarm system should be graded according to the minimum items needed to alert a deaf or hard of hearing person, while asleep or awake, for a particular level of hearing loss.

The grades are shown in Table A.1.

Table A.1 Minimum components for fire and carbon monoxide alarm system grades

Classification	Intended use	Components
Grade 1	To alert a deaf or hard of hearing person, while awake or asleep, for all levels of hearing loss	Smoke and/or carbon monoxide and/or heat alarm <sup>A)</sup> Vibrating pad Visual alarm device
Grade 2	To alert a deaf or hard of hearing person, while asleep, for all levels of hearing loss	Smoke and/or carbon monoxide and/or heat alarm <sup>A)</sup> Vibrating pad
Grade 3	To alert a deaf or hard of hearing person, while awake, for all levels of hearing loss	Smoke and/or carbon monoxide and/or heat alarm <sup>A)</sup> Visual alarm device and/or vibrating alerter
Grade 4	To alert a person with mild hearing loss <sup>B)</sup> , while asleep or awake	Smoke and/or carbon monoxide and/or heat alarm <sup>A)</sup> Low frequency sounder

*NOTE* A low frequency sounder is an option for Grades 1, 2 and 3.

<sup>A)</sup> A heat alarm should not be used as the only means of fire detection.

<sup>B)</sup> A person with mild hearing loss is one who might have difficulty following speech, particularly in noisy situations.

## Annex B (normative) Power supplies tests

### B.1 Mains power supply

**B.1.1** Connect together a system with the largest configuration specified by the manufacturer (see C.4.2). Supply the system with the nominal mains voltage (i.e. 230 V a.c.) and allow it to stabilize for 48 h or until the standby battery in the control unit is fully charged.

**B.1.2** Disconnect the standby battery, supply the system with the largest configuration from the nominal mains voltage and operate the system in a quiescent condition for a period of 72 h, followed by the system in alarm condition for a period of 4 min.

**B.1.3** Disconnect the standby battery and discharge it to its final voltage at a discharge current of  $C/20$  A, or lower, where  $C$  is the battery manufacturer's rated capacity of the battery in ampere hours (A·h).

**B.1.4** Set the mains voltage to the system at nominal mains voltage minus 15% (i.e. 195.5 V a.c.), reconnect the standby battery and allow it to charge for 24 h with the system operating in its quiescent condition.

**B.1.5** Immediately after the 24 h charging period, disconnect the mains supply and allow the system to remain supplied by the standby battery for 72 h. Immediately after this 72 h standby period, trigger an alarm and allow the system to remain in the alarm condition for 4 min. Measure and record the voltage at the battery terminals at the end of this 4 min period while the system is still in the alarm condition.

## B.2 Primary battery power supply

**B.2.1** Disconnect the battery or batteries and discharge to the point at which the battery fault warning is given. The discharge period shall be at least 30 days unless otherwise agreed between the test laboratory and the manufacturer.

**B.2.2** Reconnect the battery or batteries and trigger the unit into the alarm condition for 4 min. At the end of the 4 min, check whether the alarm meets the minimum alarm performance level requirement for that device.

**B.2.3** On a second unit, disconnect the battery or batteries and discharge to the point at which the battery fault is given as specified in **B.2.1**.

**B.2.4** Reconnect the battery or batteries and check whether the battery fault warning is given for at least 30 days.

## B.3 Standby power supply for primary battery-powered units

**B.3.1** Disconnect the primary battery source from the unit. Leave the standby power supply powering the unit for 72 h.

**B.3.2** Trigger the unit into the alarm condition for 4 min. At the end of the 4 min, check whether the alarm meets the minimum alarm performance level requirement for that device.

**B.3.3** Measure the standby battery voltage at the end of the 4 min in alarm condition and check whether it is greater or equal to the battery manufacturer's minimum specified battery voltage.

## Annex C (normative)

# General procedures for tests

## C.1 Test specimens

The specimens used in the tests shall be representative of the manufacturer's normal production with regard to their construction and calibration.

A minimum of five specimens of the alarm systems, including all of the necessary components and data, shall be provided for the tests. Each of these shall be numbered arbitrarily with a different number in the range 1 to 5.

## C.2 Atmospheric conditions for tests

Unless otherwise specified in the test procedure, testing shall be carried out after the test specimen has been allowed to stabilize in the following standard atmospheric conditions:

- temperature: 15 °C to 35 °C;
- relative humidity: 25% to 75%;
- air pressure: 86 kPa to 106 kPa.

*NOTE* If variations in these parameters have a significant effect on a measurement, then such variations should be kept to a minimum during a series of measurements carried out as part of one test on one specimen.

## C.3 Tolerances

Unless otherwise specified in the test procedure, the tolerances for the environmental test parameters shall be as given in the basic reference standards for the tests (e.g. the relevant part of BS EN 60068).

If a requirement or test procedure does not specify a tolerance or deviation limits, then deviation limits of  $\pm 5\%$  shall be applied, i.e. the parameter shall not deviate from the specified value by more than  $\pm 5\%$ .



## C.4 Operating conditions for tests

### C.4.1 Normal operation

Where a test calls for a component to be operational then, unless otherwise specified in the test procedure, all the components supplied within the system or made separately available by the manufacturer shall be connected and configured in an appropriate arrangement in accordance with the manufacturer's instructions and the power supply parameters shall be within the manufacturer's specified ranges for normal operation.

### C.4.2 Operation under maximum or minimum supply voltage conditions

*NOTE 1 In some test procedures it is necessary to operate components of the system under the conditions that result in the maximum or minimum supply voltage. In order to perform these tests, it is necessary to make an initial assessment of the supply and loading conditions for the alarm system that lead to the maximum and minimum supply voltages to the component (e.g. visual alarm device, vibrating pad, radio transmitter or receiver, etc.).*

Where a test calls for a component to be operated under maximum or minimum supply voltage conditions, the voltage supplied to the component shall be measured in the alarm condition for the various worst case combinations of the following, to determine the combinations giving the highest and lowest supply voltages to the component:

- a) largest system configuration specified by the manufacturer (i.e. system with the maximum number of visual alarm devices, vibrating pads and alarms connected);
- NOTE 2 Where the manufacturer specifies that a system can have more than one of any type of component then the test configuration should have at least one of that type and the others may be simulated by appropriate dummy loads.*
- b) smallest system configuration specified by the manufacturer (i.e. system with a minimum of one alarm, one visual alarm device and one vibrating pad connected);
- c) maximum and minimum mains supply voltages [i.e.  $(230^{+23}_{-34.5})$  V a.c. unless a wider range is specified by the manufacturer];
- d) maximum and minimum battery voltages (i.e. the voltage of a new or fully charged battery and the specified final voltage of a discharged battery, unless a wider range is specified by the manufacturer);
- e) disconnection of either the mains supply or the battery supply.

*NOTE 3 Disconnection of both the mains supply and the battery supply at the same time is not used for the purpose of these tests.*

## Annex D (normative)

## Tests for control units

### D.1 Test schedule for control units

Testing shall be carried out in accordance with the schedule of tests given in Table D.1.

The tests for control units shall be conducted in accordance with the general procedures given in Annex C and the specific procedures given in **D.2** to **D.6**.



Table D.1 Test schedule for control units

Test	Subclause	Designated specimen number (see C.1)
Functional test	6.2.6.1	All
Damp heat test	D.2	3
Cold test	D.3	3
Corrosion test	D.4	4
Impact test (for wall-mounted or ceiling-mounted units)	D.5	5
Drop test (for free-standing units)	D.6	5

## D.2 Damp heat test

*NOTE* The objective of this test is to determine whether the control unit is unduly affected by high temperatures and humidities that can occur in the service environment.

**D.2.1** Place a specimen of the control unit in an environmental chamber so that it can be observed (e.g. through a window) while being exposed to the environmental conditioning.

**D.2.2** Apply the following damp heat, steady state conditioning to the specimen in accordance with BS EN 60068-2-78. The specimen shall not be supplied with power during the conditioning, except during the last 30 min (see **D.3.3**):

- temperature:  $(40 \pm 2)$  °C;
- relative humidity:  $(93 \pm 3)\%$ ;
- duration: 4 days.

**D.2.3** During the last 30 min of the conditioning, connect the control unit in accordance with **C.4.1** and perform the functional test described in **6.2.6.1**.

**D.2.4** After a recovery period of at least 1 h at the laboratory conditions specified in **C.2**, perform the functional test described in **6.2.6.1**.

## D.3 Cold test

*NOTE* The objective of this test is to determine whether the control unit is unduly affected by low temperatures that can occur in the service environment.

**D.3.1** Place a specimen of the control unit in an environmental chamber so that it can be observed (e.g. through a window) while being exposed to the environmental conditioning.

**D.3.2** Apply the following cold conditioning to the specimen in accordance with BS EN 60068-2-1. The specimen shall not be supplied with power during the conditioning, except during the last 30 min (see **D.3.3**):

- temperature:  $(-10 \pm 3)$  °C;
- duration: 16 h.

**D.3.3** During the last 30 min of the conditioning, perform the functional test described in **6.2.6.1**.

**D.3.4** After a recovery period of at least 1 h at the laboratory conditions specified in **C.2**, perform the functional test described in **6.2.6.1**.

## D.4 Corrosion test

*NOTE* The objective of this test is to determine whether the control unit is sufficiently protected against corrosion that can occur in the service environment.

**D.4.1** Apply the following corrosion conditioning to a specimen of the control unit in accordance with BS EN 60068-2-42. The specimen shall not be supplied with power during the conditioning:

- temperature:  $(25 \pm 2)$  °C;
- relative humidity:  $(93 \pm 3)\%$ ;
- SO<sub>2</sub> concentration: a volume fraction of  $(0.002\ 5 \pm 0.000\ 5)\%$ ;
- duration: 4 days.

**D.4.2** After a recovery period of at least 1 h at the laboratory conditions specified in C.2, perform the functional test described in 6.2.6.1.

## D.5 Impact test

*NOTE* The objective of this test is to determine whether the control unit is sufficiently robust to withstand the knocks that can occur in the service environment.

**D.5.1** Mount a specimen of the control unit to a flat rigid structure (e.g. a masonry wall) with its normal fixings.

**D.5.2** Apply the following impact conditioning with a spring impact hammer in accordance with BS EN 60068-2-75 to any accessible points that could impair the correct operation of the control unit (e.g. to the front and side of the unit). The specimen shall not be supplied with power during the conditioning:

- impact energy:  $(0.5 \pm 0.04)$  J;
- number of impacts per point: 3.

*NOTE* Care should be taken to ensure that the results from one series of three blows do not influence subsequent series. In case of doubt with regard to the influence of preceding blows, the defect should be disregarded and a further three blows should be applied to the same position on a new specimen.

**D.5.3** Perform the functional test described in 6.2.6.1.

## D.6 Drop test

*NOTE* The objective of this test is to determine whether the control unit is sufficiently robust to withstand the knocks and drops that can occur in the service environment.

**D.6.1** Drop a specimen of the control unit from a height of 0.5 m onto a concrete floor once in each of six attitudes in accordance with BS EN 60068-2-31:2008, free fall procedure 1.

**D.6.2** Perform the functional test described in 6.2.6.1.

## Annex E (normative)

# Tests for radio-linked systems

## E.1 Environmental tests

**E.1.1** The radio components (transmitters and/or receivers) shall be subjected to the environmental test(s) specified for the equipment in which they are installed or with which they are closely associated (e.g. a transmitter unit mounted in or intended to be mounted adjacent to a smoke alarm shall be submitted to the environmental tests specified in BS EN 14604, and a receiver unit mounted within a control unit shall be subjected to the environmental tests in Annex D).

**E.1.2** Where the environmental tests (**E.1.1**) require operation or a functional test during conditioning, locate the other part of the radio link in close proximity to the component under test and trigger an alarm condition.

**E.1.3** Where the environmental tests (**E.1.1**) require functional testing after the conditioning, carry out a 100 m (or longer if specified by the manufacturer) range test (see **E.2**).

## **E.2 Range test**

*NOTE* The objective of this test is to determine whether the radio components achieve the required range of 100 m or longer if specified by the manufacturer, through free space within the specified range of supply voltage conditions.

**E.2.1** Arrange the antennae of the radio components in the least favourable alignment, at a distance of at least 100 m apart (or longer if specified by the manufacturer), under free field conditions or by an equivalent method agreed between the test laboratory and the manufacturer.

**E.2.2** Supply both parts of the radio link with their minimum operating voltages. For purely battery-supplied components this shall be the voltage at which the low battery fault indication is given, and for components supplied by the control unit it shall be the minimum voltage condition (see **C.4.2**).

**E.2.3** Trigger an alarm condition at the transmitter unit and monitor the receiver unit.

## **E.3 Integrity of radio link between control unit and smoke alarm test**

*NOTE* The objective of this test is to determine the integrity of the radio link between the control unit and the smoke alarm.

**E.3.1** With the smoke alarm as the radio component under test, carry out the procedure given in **E.2**.

**E.3.2** When the alarm signal is received by the receiver unit, remove the alarm condition trigger, reset the control unit, remove all power from the smoke alarm, and start a timer.

**E.3.3** Monitor the condition of the control unit.

## **E.4 Integrity of radio link between control unit and any radio-linked alarm device test**

*NOTE* The objective of this test is to determine whether there is a continuously open radio communication path between the control unit and any alarm device.

**E.4.1** Connect to the system all radio-linked alarm devices specified for the system under test, and carry out the procedure given in **E.2**.

**E.4.2** When the alarm signal is received by the receiver unit, remove the alarm condition trigger, reset the control unit, remove all power from the control unit (leaving power connected to all radio-linked alarm devices), and start a timer.

**E.4.3** Monitor the condition of the radio linked alarm devices.

## **E.5 Control unit alarm transmission continuity test**

*NOTE* The objective of this test is to determine whether there is a continuous alarm transmission from the control unit during a fire condition.

**E.5.1** With the alerter as the radio component under test, carry out the procedure given in **E.2**.

**E.5.2** When the alarm signal is received by the receiver unit (see 6.7.5), leave the control unit transmitting its alarm signal to the alerter, but acknowledge/reset the alerter.

**E.5.3** After 3 s, reactivate the operation at the alerter, start a timer and monitor the state of the alerter.

**E.5.4** Repeat E.5.1 to E.5.3 ten times.

**Annex F**  
**(normative)**  
**F.1**

## Tests for visual alarm devices

### Test schedule for visual alarm devices

Testing shall be carried out in accordance with the schedule of tests given in Table F.1.

The tests shall be conducted in accordance with the general procedures given in Annex C and the specific procedures listed in Table F.1.

Table F.1 Test schedule for visual alarm devices

Test	Method given in	Designated specimen number (see C.1)
Reproducibility test	BS EN 54-23:2010, 5.1.7	All
Dry heat test	BS EN 54-23:2010, 5.4.1.1	1
Cold test	BS EN 54-23:2010, 5.4.1.3	3
Damp heat test	BS EN 54-23:2010, 5.4.2.2	3
Corrosion test	BS EN 54-23:2010, 5.4.4	4
Impact test (for wall-mounted or ceiling-mounted beacons)	BS EN 54-23:2010, 5.4.3.2	5
Vibration test, sinusoidal	BS EN 54-23:2010, 5.4.3.3	5
Shock test	BS EN 54-23:2010, 5.4.3.1	5
Drop test (for free-standing beacons)	F.2	5

### F.2 Drop test

*NOTE* The objective of this test is to determine whether the visual alarm device is sufficiently robust to withstand the knocks and drops that can occur in the service environment.

**F.2.1** Drop a specimen of the visual alarm device from a height of 0.5 m onto a concrete floor once in each of six attitudes (i.e. two directions in each of three mutually perpendicular axes) in accordance with BS EN 60068-2-31:2008, free fall procedure 1.

**F.2.2** Monitor the specimen for false operation and fault signals during the test and for a further 2 min after the end of the test.

**F.2.3** Measure the light output level as described in BS EN 54-23:2010, Annex B, after the conditioning.

**F.2.4** Check the functioning of the light source and any indicators.

**F.2.5** Take the largest and smallest light intensities measured in F.2.3 and BS EN 54-23:2010, 5.1.7 for the same specimen and designate them as  $Q_{\max}$  and  $Q_{\min}$  respectively.

## Annex G Tests for vibrating pads

(normative)

### G.1 Test schedule for vibrating pads

Testing shall be carried out in accordance with the schedule of tests given in Table G.1.

The tests for vibrating pads shall be conducted in accordance with the general procedures given in Annex C and the specific procedures given in G.2 to G.12.

Table G.1 Test schedule for vibrating pads

Test	Subclause	Designated specimen number (see C.1)
Vibration frequency, pulse pattern and vibration intensity test	G.2	All
Reproducibility	G.3	All
Durability test	G.4	2
Dry heat test	G.5	1
Cold test	G.6	3
Damp heat test	G.7	3
Corrosion test	G.8	4
Impact	G.9	5
Vibration – external (endurance)	G.10	5
Shock	G.11	5
Drop test	G.12	5

### G.2 Vibration frequency, pulse pattern and vibration intensity test

*NOTE* The objective of this test is to determine whether the vibrating pad gives the required vibration frequency, pulse pattern and vibration intensity within the specified range of supply voltage conditions.

#### G.2.1 Apparatus

**G.2.1.1** *Rigid, support structure* for test equipment (item A in Figure G.1), with a single suspension point for suspension wires (item B in Figure G.1).

**G.2.1.2** *Steel suspension wires*, (4.06 ±0.1) mm thick [8 SWG (standard wire gauge)], (458 ±10) mm length (item C in Figure G.1).

**G.2.1.3** *Test specimen*, securely affixed in its primary usage plane, as specified in the manufacturer's instructions (item D in Figure G.1).

**G.2.1.4** *Support plate*, fitted with suitable means to rigidly secure the test specimen (item E in Figure G.1).

*NOTE* A support plate with a mass of about 300 g is normally satisfactory.

**G.2.1.5** *Accelerometer*, with a mass of less than 5 g, fixed rigidly to the centre of the support plate (item F in Figure G.1). The accelerometer's primary plane of measurement shall be perpendicular to the primary usage plane of the test specimen. The output from the accelerometer shall be suitably amplified and integrated so that the peak acceleration induced in the centre of the support plate by the vibrating pad can be measured.

Figure G.1 Test apparatus for measuring vibration intensity of vibrating pads

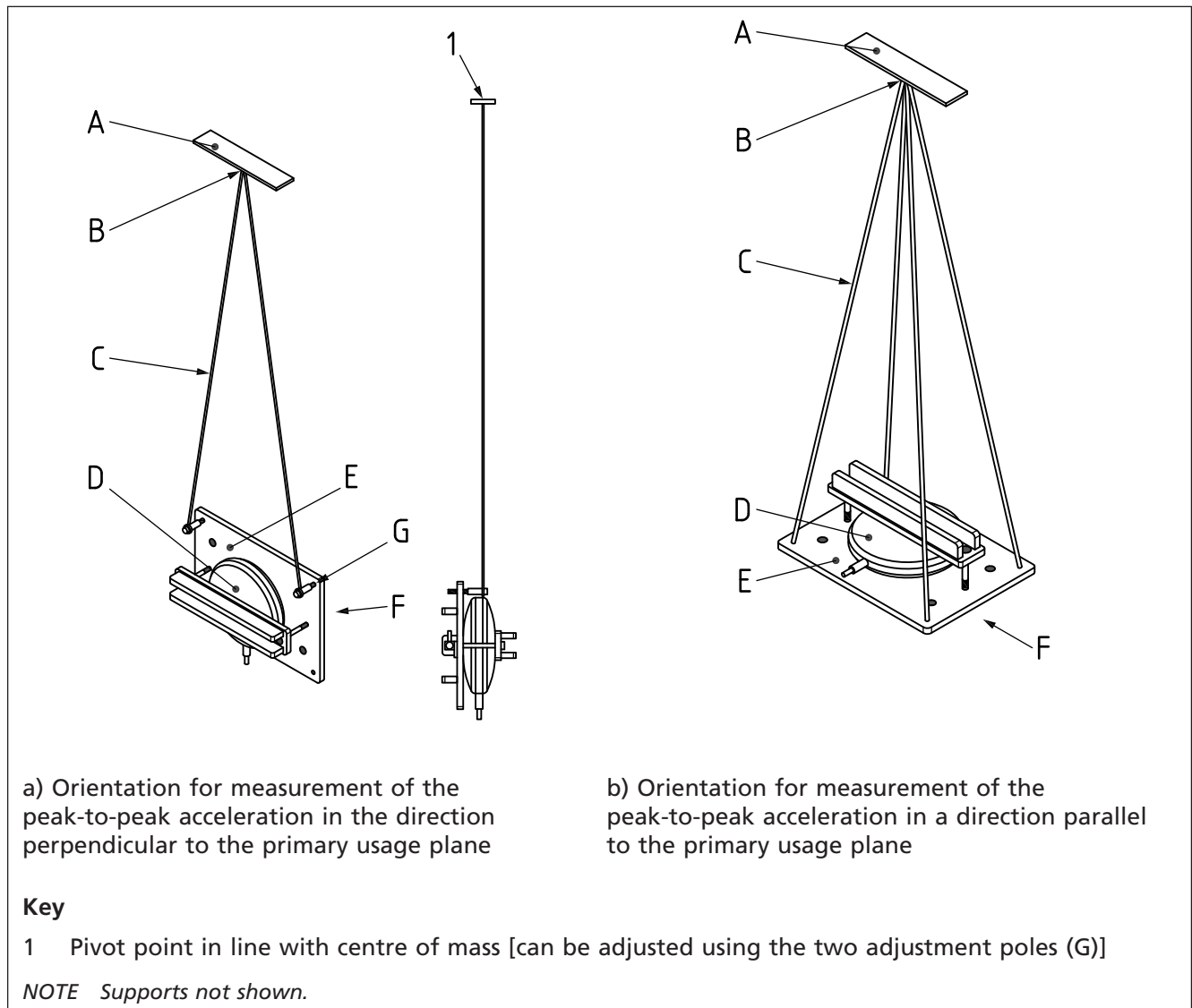

## G.2.2 Procedure

**G.2.2.1** Attach the test apparatus to a firm surface (e.g. a concrete beam).

**G.2.2.2** Place a specimen of the vibrating pad in the test apparatus (G.2.1) so that it is in the centre of the support plate in the orientation shown in Figure G.1a).

**G.2.2.3** Connect the specimen to its control circuit configured for the minimum voltage condition (see C.4.2) and trigger an alarm.

**G.2.2.4** Monitor the output of the accelerometer amplifier/integrator to determine the fundamental frequency, pulse pattern and vibration intensity produced on the support plate.

**G.2.2.5** Repeat G.2.2.2 to G.2.2.4 but with the vibrating pad configured for the maximum voltage condition (see C.4.2).

**G.2.2.6** Measure the peak-to-peak acceleration in  $g$  (gravitational acceleration at  $9.81 \text{ m}\cdot\text{s}^{-2}$ ) using the apparatus shown in Figure G.1, then normalize it for a 100 g support plate using the following formula:

$$a_n = a_m (m_s + m_{vp}) / (100 + m_{vp})$$

where:

- $a_n$  is the normalized vibration intensity, expressed as acceleration of free fall ( $g$ );
- $a_m$  is the measured acceleration, expressed as acceleration of free fall ( $g$ );
- $m_s$  is the mass of the support plate include fixings and accelerometer, in grams ( $g$ );
- $m_{vp}$  is the mass of the vibrating pad, in grams ( $g$ ).

#### EXAMPLE

Measured peak-to-peak acceleration  $a_m = 4.4 \text{ g}$

Mass of support plate  $m_s = 300 \text{ g}$

Mass of vibrating pad  $m_{vp} = 127 \text{ g}$

$a_n = 4.4 (300+127)/(100+127) = 8.21 \text{ g}$  normalized acceleration

**G.2.2.7** Repeat **G.2.2.2** to **G.2.2.6** but with the vibrating pad orientated as shown in Figure G.1b).

### G.3 Reproducibility

*NOTE* The objective of this test is to show that the vibration intensity of the device does not vary unduly from specimen to specimen and to establish vibration intensity data for comparison with the vibration intensity measured during and/or after the environmental tests specified in this standard.

The vibration intensity of all the specimens shall be measured as described in **G.2**.

The measurement shall be recorded in  $g$  (acceleration units of  $9.81 \text{ m}\cdot\text{s}^{-2}$ ) for each specimen and the normalized vibration intensity of the strongest and weakest specimen shall be represented by  $a_{n,max}$  and  $a_{n,min}$  respectively.

### G.4 Durability test

*NOTE* The objective of this test is to determine whether the vibrating pad is sufficiently robust and continues to give the required vibration frequency, pulse pattern and vibration intensity after prolonged operation (e.g. a reasonable period of normal operation and routine testing).

#### G.4.1 Apparatus

The apparatus specified in **G.2.1** shall be used.

#### G.4.2 Procedure

**G.4.2.1** Place a specimen of the vibrating pad clamped firmly between two soft foam pads to simulate a pillow or mattress), so that the vibrating pad is in the orientation specified in the manufacturer's instructions.

**G.4.2.2** Connect the specimen to its control circuit configured for the maximum voltage condition (see **C.4.2**).

*NOTE* For vibration pads powered by primary battery or batteries, a power supply can be used for this test in lieu of the battery.

**G.4.2.3** Subject the specimen to the following durability cycle 100 times:

- a) trigger the system into the alarm condition and maintain it for 1 h;
- b) reset the system and allow it to remain in the non-alarm condition for 1 h.

**G.4.2.4** After the last hour in the non-alarm condition, mount the vibration as shown in Figure G.1, trigger the system into the alarm condition and measure the vibration frequency, pulse pattern and vibration intensity, as described in G.2.2, for the minimum voltage condition (i.e. G.2.2.2 to G.2.2.4). Take the largest and smallest vibration intensities measured in G.4.2.4 and G.3 for the same specimen and designate them as  $a_{n,max}$  and  $a_{n,min}$  respectively.

## G.5 Dry heat test (operational)

*NOTE* The objective of this test is to determine whether the vibrating pad is unduly affected by high temperatures that can occur in the service environment.

**G.5.1** Place the specimen in an environmental chamber suspended as specified in G.2.1.

**G.5.2** The specimen shall be maintained in the quiescent state during the conditioning period except during the last hour when it shall be giving a vibration alarm signal.

**G.5.3** The air temperature in the environment chamber shall be increased to the test temperature to  $(55 \pm 2)$  °C at a rate not exceeding 1 K/min.

**G.5.4** During the last hour of the conditioning, connect the vibrating pad to the rest of an alarm kit configured for the minimum voltage condition (see C.4.2) and trigger an alarm. Monitor the output from the accelerometer (suitably amplified as required) and measure the frequency and pulse pattern of the vibration. Take the largest and smallest vibration intensities measured in G.5.4 and G.3 for the same specimen and designate them as  $a_{n,max}$  and  $a_{n,min}$  respectively.

**G.5.5** After a recovery period of at least 1 h at the laboratory conditions specified in C.2, trigger the system into the alarm condition and measure the vibration frequency, pulse pattern and vibration intensity, as described in G.2.2, for the minimum voltage condition (i.e. G.2.2.2 to G.2.2.4). Take the largest and smallest vibration intensities measured in G.5.5 and G.3 for the same specimen and designate them as  $a_{n,max}$  and  $a_{n,min}$  respectively.

## G.6 Cold test (operational)

*NOTE* The objective of this test is to determine whether the vibrating pad is unduly affected by low temperatures that can occur in the service environment.

**G.6.1** Place the specimen in an environmental chamber suspended as specified in G.2.1.

**G.6.2** Apply the following cold conditioning to the specimen in accordance with BS EN 60068-2-1. The air temperature in the environment chamber shall be reduced to the required temperature at a rate not exceeding 1 K/min:

- a) required temperature:  $(-10 \pm 3)$  °C;
- b) duration: 16 h.

**G.6.3** During the last hour of the conditioning, connect the vibrating pad to the rest of an alarm kit configured for the minimum voltage condition (see C.4.2) and trigger an alarm. Monitor the output from the accelerometer (suitably amplified as required) and measure the frequency and pulse pattern of the vibration. Take the largest and smallest vibration intensities measured in G.6.3 and G.3 for the same specimen and designate them as  $a_{n,max}$  and  $a_{n,min}$  respectively.



**G.6.4** After a recovery period of at least 1 h at the laboratory conditions specified in **C.2**, measure the vibration frequency, pulse pattern and vibration intensity, as described in **G.2.2**, for the minimum voltage condition (i.e. **G.2.2.2** to **G.2.2.4**). Take the largest and smallest vibration intensities measured in **G.6.4** and **G.3** for the same specimen and designate them as  $a_{n,max}$  and  $a_{n,min}$  respectively.

## **G.7 Damp heat test (operational)**

*NOTE* The objective of this test is to determine whether the vibrating pad is unduly affected by high temperatures and humidities that can occur in the service environment.

**G.7.1** Place the specimen in an environmental chamber suspended as specified in **G.2.1**.

**G.7.2** Apply the following damp heat, steady state conditioning to the specimen in accordance with BS EN 60068-2-78:

- a) temperature:  $(40 \pm 2)$  °C;
- b) relative humidity:  $(93 \pm 3)\%$ ;
- c) duration: 4 days.

**G.7.3** During the last hour of the conditioning, connect the vibrating pad to the rest of an alarm kit configured for the minimum voltage condition (see **C.4.2**) and trigger an alarm. Monitor the output from the accelerometer (suitably amplified as required) and measure the frequency and pulse pattern of the vibration. Take the largest and smallest vibration intensities measured in **G.7.3** and **G.3** for the same specimen and designate them as  $a_{n,max}$  and  $a_{n,min}$  respectively.

**G.7.4** After a recovery period of at least 1 h at the laboratory conditions specified in **C.2**, trigger the system into the alarm condition and measure the vibration frequency, pulse pattern and vibration intensity, as described in **G.2.2**, for the minimum voltage condition (i.e. **G.2.2.2** to **G.2.2.4**). Take the largest and smallest vibration intensities measured in **G.7.4** and **G.3** for the same specimen and designate them as  $a_{n,max}$  and  $a_{n,min}$  respectively.

## **G.8 Corrosion test**

*NOTE* The objective of this test is to determine whether the vibrating pad is sufficiently protected against corrosion that can occur in the service environment.

**G.8.1** Apply the following corrosion conditioning to a specimen of the vibrating pad in accordance with BS EN 60068-2-42. The specimen shall not be supplied with power during the conditioning:

- a) temperature:  $(25 \pm 2)$  °C;
- b) relative humidity:  $(93 \pm 3)\%$ ;
- c) SO<sub>2</sub> concentration: volume fraction of  $(0.002\ 5 \pm 0.000\ 5)\%$ ;
- d) duration: 4 days.

**G.8.2** After a recovery period of at least 1 h at the laboratory conditions specified in **C.2**, connect to the vibrating pad, in place of its battery (where fitted), a suitable laboratory power supply, and adjust its output voltage to simulate a battery discharged to 10% above the voltage at which a low battery warning would be given. Trigger the system into the alarm condition and measure the vibration frequency, pulse pattern and vibration intensity, as described in **G.2.2**, for the minimum voltage condition (i.e. **G.2.2.2** to **G.2.2.4**). Take the largest and smallest vibration intensities measured in **G.8.2** and **G.3** for the same specimen and designate them as  $a_{n,max}$  and  $a_{n,min}$  respectively.

## G.9 Impact test

*NOTE* The objective of this test is to determine whether the vibrating pad is sufficiently robust to withstand the knocks that can occur in the service environment.

**G.9.1** Mount a specimen in accordance with the manufacturer's instructions.

**G.9.2** Apply the following impact conditioning with a spring impact hammer in accordance with BS EN 60068-2-75 to any accessible points that could impair the correct operation of the control unit (e.g. to the front and side of the unit). The specimen shall be in the powered quiescent state during the conditioning.

- impact energy:  $(0.5 \pm 0.04)$  J;
- number of impacts per point: 3.

*NOTE* Care should be taken to ensure that the results from one series of three blows do not influence subsequent series. In case of doubt with regard to the influence of preceding blows, the defect should be disregarded and a further three blows should be applied to the same position on a new specimen.

**G.9.3** After a recovery period of at least 1 h at the laboratory conditions specified in **C.2**, trigger the system into the alarm condition and measure the vibration frequency, pulse pattern and vibration intensity, as described in **G.2.2**, for the minimum voltage condition (i.e. **G.2.2.2** to **G.2.2.4**). Take the largest and smallest vibration intensities measured in **G.9.3** and **G.3** for the same specimen and designate them as  $a_{n,max}$  and  $a_{n,min}$  respectively.

## G.10 Vibration – external (endurance)

*NOTE* The objective of this test is to demonstrate the ability of the vibrating pad to withstand the long term effects of external vibration at levels appropriate to the service environment.

**G.10.1** The test apparatus and procedure shall be as described in BS EN 60068-2-6:2008, Test F2.

**G.10.2** The specimen shall be mounted on a rigid fixture and the vibration shall be applied in each of three mutually perpendicular axes in turn. The specimen shall be mounted such that one of the three axes is perpendicular to its normal mounting plane. The specimen shall not be supplied with power during the conditioning.

**G.10.3** The following test conditions shall be applied.

- a) frequency range: 10 Hz to 150 Hz;
- b) acceleration amplitude:  $10 \text{ m}\cdot\text{s}^{-2}$ ;
- c) number of axes: 3;
- d) sweep rate: 1;
- e) number of sweep cycles per axis per functional condition: 20.

**G.10.4** After the conditioning, mount the vibrating pad as shown in Figure G.1, trigger the vibrating pad into the alarm condition and measure the vibration frequency, pulse pattern and vibration intensity as for the maximum voltage condition. Take the largest and smallest vibration intensities measured in **G.10.4** and **G.3** for the same specimen and designate them as  $a_{n,max}$  and  $a_{n,min}$  respectively.

## G.11 Shock test

*NOTE* The objective of this test is to demonstrate the immunity of the visual alarm device to mechanical shocks, which are likely to occur, albeit infrequently, in the anticipated service environment.

**G.11.1** The test apparatus and procedure shall generally be as described in BS EN 60068-2-27:2009, Test Ea, except that the conditioning shall be as follows:

- a) pulse duration: 6 m/s;
- b) maximum acceleration:  $10 \times (100 - M) \text{ m/s}^2$  (where  $M$  is the mass of the vibrating pad in kilograms);
- c) number of shock directions per axis: 6;
- d) number of pulses per direction: 3.

**G.11.2** The specimen shall be mounted on a rigid fixture and shall be maintained in the quiescent state during the conditioning period.

**G.11.3** The specimen shall be monitored for false operation and fault signals during the conditioning period and a further 2 min after the end of the conditioning period.

**G.11.4** After the conditioning, trigger the vibrating pad into alarm condition and measure the vibration frequency, pulse pattern and vibration intensity as described in **G.2.2** for the minimum voltage condition. Take the largest and smallest vibration intensities measured in **G.11.4** and **G.3** for the same specimen and designate them as  $a_{n,\max}$  and  $a_{n,\min}$  respectively.

## G.12 Drop test

*NOTE* The objective of this test is to determine whether the vibrating pad is sufficiently robust to withstand the knocks and drops that can occur in the service environment.

**G.12.1** Drop a specimen of the vibrating pad from a height of 0.5 m onto a concrete floor once in each of six attitudes (i.e. two directions in each of three mutually perpendicular axes) in accordance with BS EN 60068-2-31:2008, free fall procedure 1. The specimen shall be maintained in the quiescent state during the conditioning period. The specimen shall be monitored for false operation and for fault signal during the conditioning period and a further 2 min after the end of the conditioning period.

**G.12.2** After completing the six drops, trigger the system into the alarm condition and measure the vibration frequency, pulse pattern and vibration intensity, as described in **G.2.2**, for the minimum voltage condition (i.e. **G.2.2.2** to **G.2.2.4**). Take the largest and smallest vibration intensities measured in **G.12.2** and **G.3** for the same specimen and designate them as  $a_{n,\max}$  and  $a_{n,\min}$  respectively.

## Annex H (normative)

# Tests for vibrating alerters

## H.1 Test schedule for vibrating alerters

Testing shall be carried out in accordance with the schedule of tests given in Table H.1.

The tests for vibrating alerters shall be conducted in accordance with the general procedures given in Annex C and the specific procedures given in **H.2** to **H.12**.

Table H.1 Test schedule for vibrating alerters

Test	Subclause	Designated specimen number (see C.1)
Vibration frequency, pulse pattern and vibration intensity test	H.2	All
Reproducibility	H.3	All
Durability test	H.4	2
Dry heat test	H.5	1
Cold test	H.6	3
Damp heat test	H.7	3
Corrosion test	H.8	4
Impact test	H.9	5
Vibration test – external (endurance)	H.10	5
Shock test	H.11	5
Drop test	H.12	5

## H.2 Vibration frequency and pulse pattern test

*NOTE* The objective of this test is to determine whether the vibrating alerter gives the required vibration frequency and pulse pattern within the specified range of supply voltage conditions.

### H.2.1 Apparatus

**H.2.1.1** *Rigid, support structure* for test equipment (item A in Figure H.1), with a single suspension point for suspension wires (item B in Figure H.1).

**H.2.1.2** *Steel suspension wires*, (4.06 ±0.1) mm thick [8 SWG (standard wire gauge)], (458 ±10) mm length (item C in Figure H.1).

**H.2.1.3** *Test specimen*, securely affixed in its primary usage plane, as defined in the manufacturer's instructions (item D in Figure H.1).

**H.2.1.4** *Support plate*, fitted with suitable means to rigidly secure the test specimen (item E in Figure H.1).

**H.2.1.5** *Accelerometer*, with a mass of less than 5 g, fixed rigidly to the centre of the support plate (item F in Figure H.1). The accelerometer's primary plane of measurement shall be perpendicular to the primary usage plane of the test specimen. The output from the accelerometer shall be suitably amplified and integrated so that the peak acceleration induced in the centre of the support plate by the vibrating alerter can be measured.

### H.2.2 Procedure

**H.2.2.1** Fit a specimen of the vibrating alerter with a battery discharged to a voltage just above the voltage at which a low battery warning would be given. This voltage shall be equal to the low battery trip point voltage plus 10% of the difference between the nominal battery voltage and the low battery trip point voltage. Switch on the vibrating alerter and place it in the test apparatus (H.2.1) so that it is in the centre of the support plate, in the orientation specified in the manufacturer's instructions.

**H.2.2.2** Place an operating alarm system that incorporates a transmitter, such that the transmitter can trigger the alerter into an alarm state during a fire alarm condition.

**H.2.2.3** Monitor the output of the accelerometer amplifier/integrator to determine the fundamental frequency, pulse pattern and vibration intensity produced on the support plate.

Figure H.1 Test apparatus for measuring vibration intensity of vibrating alerters

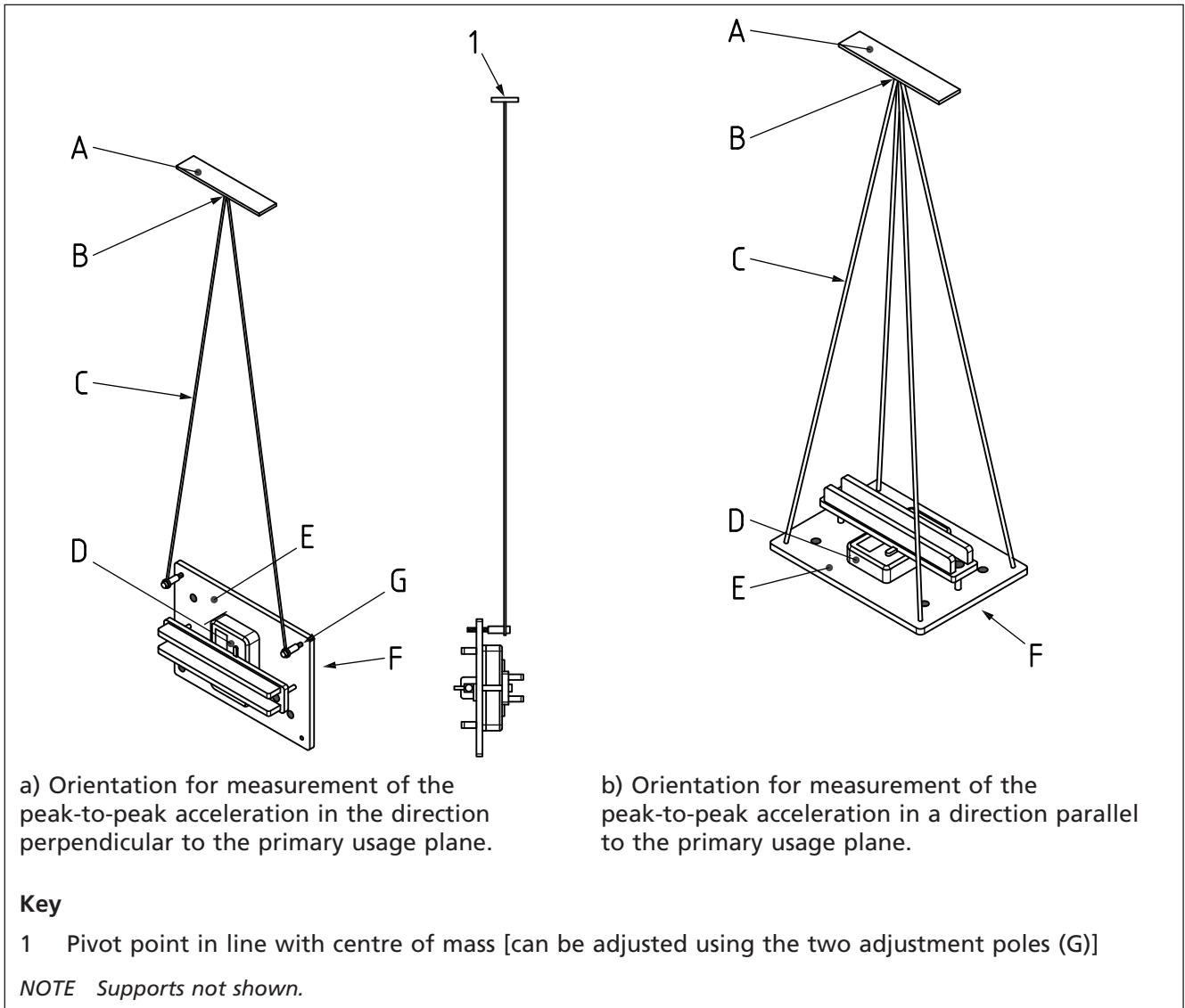

H.2.2.4 Repeat steps H.2.2.1 to H.2.2.3 but with the vibrating alerter fitted with a new battery.

H.2.2.5 Measure the peak-to-peak acceleration in *g* (gravitational acceleration at  $9.81 \text{ m}\cdot\text{s}^{-2}$ ) using the apparatus shown in Figure H.1, then normalize it for a 100 g support plate using the following formula:

$$a_n = a_m (m_s + m_{vp}) / (100 + m_{vp})$$

where:

- $a_n$  is the normalized vibration intensity, expressed as acceleration of free fall (*g*);
- $a_m$  is the measured acceleration, expressed as acceleration of free fall (*g*);
- $m_s$  is the mass of the support plate include fixings and accelerometer, in grams (*g*);
- $m_{vp}$  is the mass of the vibrating pad, in grams (*g*).

*NOTE An example is given in G.2.2.6.*

### H.3 Reproducibility

*NOTE* The objective of this test is to show that the vibration intensity of the device does not vary unduly from specimen to specimen and to establish vibration intensity data for comparison with the vibration intensity measured during and/or after the environmental tests specified in this standard.

The vibration intensity of all the specimens shall be measured as described in H.2.

The measurement shall be recorded in  $g$  (acceleration units of  $9.81 \text{ m}\cdot\text{s}^{-2}$ ) for each specimen and the normalized vibration intensity of the strongest and weakest specimen shall be represented by  $a_{n,\text{max}}$  and  $a_{n,\text{min}}$  respectively.

### H.4 Durability test

*NOTE* The objective of this test is to determine whether the vibrating alerter is sufficiently robust and continues to give the required vibration frequency and pulse pattern after prolonged operation (e.g. a reasonable period of normal operation and routine testing).

#### H.4.1 Apparatus

The apparatus specified in H.2.1 shall be used.

#### H.4.2 Procedure

**H.4.2.1** Place a specimen of the vibrating alerter clamped firmly between two soft foam pads (to simulate a pillow or mattress), so that the vibrating pad is in the orientation specified in the manufacturer's instructions.

**H.4.2.2** Connect the specimen to its control circuit configured for the maximum voltage condition (see C.4.2).

*NOTE* A power supply can be used in lieu of the battery for this test.

**H.4.2.3** Subject the specimen to the following durability cycle 100 times:

- a) trigger the system into the alarm condition and maintain it for 1 h;
- b) reset the system and allow it to remain in the non-alarm condition for 1 h.

**H.4.2.4** After the last hour in the non-alarm condition, mount the vibration as shown in Figure H.1, trigger the system into the alarm condition and measure the vibration frequency, pulse pattern and vibration intensity, as described in H.2.2, for the minimum voltage condition (i.e. H.2.2.2 to H.2.2.4). Take the largest and smallest vibration intensities measured in H.4.2.4 and H.3 for the same specimen and designate them as  $a_{n,\text{max}}$  and  $a_{n,\text{min}}$  respectively.

### H.5 Dry heat test (operational)

*NOTE* The objective of this test is to determine whether the vibrating alerter is unduly affected by high temperatures that can occur in the service environment.

**H.5.1** Place the specimen in an environmental chamber suspended as specified in H.2.1.

**H.5.2** The specimen shall be maintained in the quiescent state during the 16 h conditioning period except during the last hour when it shall be giving a vibration alarm signal.

**H.5.3** The air temperature in the environment chamber shall be increased to the test temperature to  $(55 \pm 2) \text{ }^\circ\text{C}$  at a rate not exceeding  $1 \text{ K/min}$ .

**H.5.4** During the last hour of the conditioning, connect the vibrating alerter to the rest of an alarm kit configured for the minimum voltage condition (see **C.4.2**) and trigger an alarm. Monitor the output from the accelerometer (suitably amplified as required) and measure the frequency and pulse pattern of the vibration. Take the largest and smallest vibration intensities measured in **H.5.4** and **H.3** for the same specimen and designate them as  $a_{n,max}$  and  $a_{n,min}$  respectively.

**H.5.5** After a recovery period of at least 1 h at the laboratory conditions specified in **C.2**, trigger the system into the alarm condition and measure the vibration frequency, pulse pattern and vibration intensity, as described in **H.2.2**, for the minimum voltage condition (i.e. **H.2.2.2** to **H.2.2.4**). Take the largest and smallest vibration intensities measured in **H.5.5** and **H.3** for the same specimen and designate them as  $a_{n,max}$  and  $a_{n,min}$  respectively.

## H.6 Cold test (operational)

*NOTE* The objective of this test is to determine whether the vibrating alerter is unduly affected by low temperatures that can occur in the service environment.

**H.6.1** Place the specimen in an environmental chamber suspended as specified in **H.2.1**.

**H.6.2** Apply the following cold conditioning to the specimen in accordance with BS EN 60068-2-1. The air temperature in the environment chamber shall be reduced to the required temperature at a rate not exceeding 1 K/min.:

- a) required temperature:  $(-10 \pm 3)$  °C;
- b) duration: 16 h.

**H.6.3** During the last hour of the conditioning, connect the vibrating alerter to the rest of an alarm kit configured for the minimum voltage condition (see **C.4.2**) and trigger an alarm. Monitor the output from the accelerometer (suitably amplified as required) and measure the frequency and pulse pattern of the vibration. Take the largest and smallest vibration intensities measured in **H.6.3** and **H.3** for the same specimen and designate them as  $a_{n,max}$  and  $a_{n,min}$  respectively.

**H.6.4** After a recovery period of at least 1 h at the laboratory conditions specified in **C.2**, measure the vibration frequency, pulse pattern and vibration intensity, as described in **H.2.2**, for the minimum voltage condition (i.e. **H.2.2.2** to **H.2.2.4**). Take the largest and smallest vibration intensities measured in **H.6.4** and **H.3** for the same specimen and designate them as  $a_{n,max}$  and  $a_{n,min}$  respectively.

## H.7 Damp heat test (operational)

*NOTE* The objective of this test is to determine whether the vibrating alerter is unduly affected by high temperatures and humidities that can occur in the service environment.

**H.7.1** Place the specimen in an environmental chamber suspended as specified in **H.2.1**.

**H.7.2** Apply the following damp heat, steady state conditioning to the specimen in accordance with BS EN 60068-2-78:

- a) temperature:  $(40 \pm 2)$  °C;
- b) relative humidity:  $(93 \pm 3)\%$ ;
- c) duration: 10 days.



**H.7.3** During the last hour of the conditioning, connect the vibrating alerter to the rest of an alarm kit configured for the minimum voltage condition (see **C.4.2**) and trigger an alarm. Monitor the output from the accelerometer (suitably amplified as required) and measure the frequency and pulse pattern of the vibration. Take the largest and smallest vibration intensities measured in **H.7.3** and **H.3** for the same specimen and designate them as  $a_{n,max}$  and  $a_{n,min}$  respectively.

**H.7.4** After a recovery period of at least 1 h at the laboratory conditions specified in **C.2**, trigger the system into the alarm condition and measure the vibration frequency, pulse pattern and vibration intensity, as described in **H.2.2**, for the minimum voltage condition (i.e. **H.2.2.2** to **H.2.2.4**). Take the largest and smallest vibration intensities measured in **H.7.4** and **H.3** for the same specimen and designate them as  $a_{n,max}$  and  $a_{n,min}$  respectively.

## H.8 Corrosion test

*NOTE* The objective of this test is to determine whether the vibrating alerter is sufficiently protected against corrosion that can occur in the service environment.

**H.8.1** Apply the following corrosion conditioning to a specimen of the vibrating alerter in accordance with BS EN 60068-2-42. The specimen shall not be supplied with power during the conditioning:

- a) temperature:  $(25 \pm 2)$  °C;
- b) relative humidity:  $(93 \pm 3)\%$ ;
- c) SO<sub>2</sub> concentration: a volume fraction of  $(0.002\ 5 \pm 0.000\ 5)\%$ ;
- d) duration: 4 days.

**H.8.2** After a recovery period of at least 1 h at the laboratory conditions specified in **C.2**, connect to the vibrating alerter, in place of its battery (where fitted), a suitable laboratory power supply, and adjust its output voltage to simulate a battery discharged to 10% above the voltage at which a low battery warning would be given. Trigger the system into the alarm condition and measure the vibration frequency, pulse pattern and vibration intensity, as described in **H.2.2**, for the minimum voltage condition (i.e. **H.2.2.2** to **H.2.2.4**). Take the largest and smallest vibration intensities measured in **H.8.2** and **H.3** for the same specimen and designate them as  $a_{n,max}$  and  $a_{n,min}$  respectively.

## H.9 Impact test

*NOTE* The objective of this test is to determine whether the vibrating alerter is sufficiently robust to withstand the knocks that can occur in the service environment.

**H.9.1** Mount a specimen of the vibrating alerter in accordance with the manufacturer's instructions.

**H.9.2** Apply the following impact conditioning with a spring impact hammer in accordance with BS EN 60068-2-75 to any accessible points that could impair the correct operation of the vibrating alerter (e.g. to the front and side of the unit). The specimen shall be in the powered quiescent state during the conditioning:

- impact energy:  $(0.5 \pm 0.04)$  J;
- number of impacts per point: 3.

*NOTE* Care should be taken to ensure that the results from one series of three blows do not influence subsequent series. In case of doubt with regard to the influence of preceding blows, the defect should be disregarded and a further three blows should be applied to the same position on a new specimen.

**H.9.3** After a recovery period of at least 1 h at the laboratory conditions specified in C.2, trigger the system into the alarm condition and measure the vibration frequency, pulse pattern and vibration intensity, as described in H.2.2, for the minimum voltage condition (i.e. H.2.2.2 to H.2.2.4). Take the largest and smallest vibration intensities measured in H.9.3 and H.3 for the same specimen and designate them as  $a_{n,max}$  and  $a_{n,min}$  respectively.

## H.10 Vibration – external (endurance)

*NOTE* The objective of this test is to demonstrate the ability of the vibrating alerter to withstand the long term effects of external vibration at levels appropriate to the service environment.

**H.10.1** The test apparatus and procedure shall be as described in BS EN 60068-2-6:2008, Test G2.

**H.10.2** The specimen shall be mounted on a rigid fixture and the vibration shall be applied in each of three mutually perpendicular axes in turn. The specimen shall be mounted such that one of the three axes is perpendicular to its normal mounting plane. The specimen shall not be supplied with power during the conditioning.

**H.10.3** The following test conditions shall be applied:

- a) frequency range: 10 Hz to 150 Hz;
- b) acceleration amplitude: 10 (1)  $m \cdot s^{-2}$  ( $g$ );
- c) number of axes: 3;
- d) sweep rate: 1;
- e) number of sweep cycles per axis per functional condition: 20.

**H.10.4** After the conditioning mount the vibrating alerter as shown in Figure H.1, trigger the vibrating alerter into the alarm condition and measure the vibration frequency, pulse pattern and vibration intensity as for the maximum voltage condition. Take the largest and smallest vibration intensities measured in H.10.4 and H.3 for the same specimen and designate them as  $a_{n,max}$  and  $a_{n,min}$  respectively.

## H.11 Shock test

*NOTE* The objective of this test is to demonstrate the immunity of the visual alarm device to mechanical shocks, which are likely to occur, albeit infrequently, in the anticipated service environment.

**H.11.1** The test apparatus and procedure shall generally be as described in BS EN 60068-2-27:2009, Test Ea, except that the conditioning shall be as follows:

- a) pulse duration: 6 m/s;
- b) maximum acceleration:  $10 \times (100 - M) m/s^2$  (where  $M$  is the mass of the vibrating pad in kilograms);
- c) number of shock directions per axis: 6;
- d) number of pulses per direction: 3.

**H.11.2** The specimen shall be mounted on a rigid fixture and shall be maintained in the quiescent state during the conditioning period.

**H.11.3** The specimen shall be monitored for false operation and fault signals during the conditioning period and a further 2 min after the end of the conditioning period.

**H.11.4** After the conditioning, trigger the vibrating alerter into alarm condition and measure the vibration frequency, pulse pattern and vibration intensity as described in **H.2.2** for the minimum voltage condition. Take the largest and smallest vibration intensities measured in **H.11.4** and **H.3** for the same specimen and designate them as  $a_{n,max}$  and  $a_{n,min}$  respectively.

## H.12 Drop test

*NOTE* The objective of this test is to determine whether the vibrating alerter is sufficiently robust to withstand the knocks and drops that can occur in the service environment.

**H.12.1** Fit a specimen of the vibrating alerter with a new fully charged principal battery and switch it on.

**H.12.2** Subject the specimen to six drops from a height of 0.5 m onto a hard surface in accordance with BS EN 60068-2-31:2008, free fall procedure 1.

**H.12.3** After completing the six drops, trigger the system into the alarm condition and measure the vibration frequency and pulse pattern, as described in **H.2.2**, for the discharged principal battery condition (i.e. **H.2.2.1** to **H.2.2.3**).

**H.12.4** Fit a specimen of the vibrating alerter without a principal battery but with a new fully charged backup power supply and switch it on.

**H.12.5** Subject the specimen to six drops from a height of 0.5 m onto a hard surface in accordance with BS EN 60068-2-31:2008, free fall procedure 1.

**H.12.6** After completing the six drops, trigger the system into the alarm condition and measure the vibration frequency and pulse pattern, as described in **H.2.2**, for the discharged backup battery condition (i.e. **H.2.2.1** to **H.2.2.3**).

**H.12.7** Drop a specimen of the vibrating alerter from a height of 0.5 m onto a concrete floor once in each of six attitudes (i.e. two directions in each of three mutually perpendicular axes) in accordance with BS EN 60068-2-31:2008, free fall procedure 1. The specimen shall be maintained in the quiescent state during the conditioning period. The specimen shall be monitored for false operation and for fault signal during the conditioning period and a further 2 min after the end of the conditioning period.

**H.12.8** After completing the six drops, trigger the system into the alarm condition and measure the vibration frequency, pulse pattern and vibration intensity, as described in **H.2.2**, for the minimum voltage condition (i.e. **H.2.2.2** to **H.2.2.4**). Take the largest and smallest vibration intensities measured in **H.12.8** and **H.3** for the same specimen and designate them as  $a_{n,max}$  and  $a_{n,min}$  respectively.

## Annex I (normative)

### Tests for low frequency sounders

#### I.1 Test schedule for low frequency sounders

Testing shall be carried out in accordance with the schedule of tests given in Table I.1.

The tests for low frequency sounders shall be conducted in accordance with the general procedures given in Annex C and the specific procedures listed in Table I.1.

Table I.1 Test schedule for low frequency sounders

Test	Subclause	Designated specimen number (see C.1)
Reproducibility	BS EN 54-3:2001, 5.2	All
Durability test	BS EN 54-3:2001, 5.4	2
Dry heat test	BS EN 54-3:2001, 5.5	3
Cold test	BS EN 54-3:2001, 5.7	3
Damp heat test	BS EN 54-3:2001, 5.8	3
Corrosion test	BS EN 54-3:2001, 5.11	4
Impact test	BS EN 54-3:2001, 5.13	5
Vibration test, sinusoidal	BS EN 54-3:2001, 5.14	5
Shock test	BS EN 54-3:2001, 5.12	5
Drop test	I.2	5

## I.2 Drop test

*NOTE* This test is only applicable to low frequency sounders designed to be free-standing, e.g. devices that cannot be rigidly fixed to a wall or other solid surface.

**I.2.1** Drop a specimen of the low frequency sounder from a height of 0.5 m onto a concrete floor once in each of six attitudes in accordance with BS EN 60068-2-31:2008, free fall procedure 1.

**I.2.2** Trigger the system, as configured in C.4.1, into the alarm condition and measure the sound output from the low frequency sounder.

## Bibliography

### Standards publications

BS EN 12182, *Assistive products for persons with disability – General requirements and test methods*

BS EN 50292, *Electrical apparatus for the detection of carbon monoxide in domestic premises, caravans and boats – Guide on the selection, installation, use and maintenance*

BS EN ISO 9000, *Quality management systems – Fundamentals and vocabulary*

BS EN ISO 9001, *Quality management systems – Requirements.*

BS EN ISO 9004, *Managing for the sustained success of an organization – A quality management approach*

BS EN ISO 9999, *Assistive products for persons with disability – Classification and terminology*

### Other publications

- [1] GREAT BRITAIN. Consumer Protection Act 1987. London: HMSO.
- [2] GREAT BRITAIN. Batteries and Accumulators (Containing Dangerous Substances) (Amendment) Regulations 2001. London: HMSO.
- [3] GREAT BRITAIN. Electrical Equipment (Safety) Regulations 1994. London: HMSO.
- [4] EUROPEAN COMMUNITIES. 1999/5/EC. Directive 1999/5/EC of the European Parliament and of the Council of 9 March 1999 on radio equipment and telecommunications terminal equipment and the mutual recognition of their conformity. (Radio and Telecommunication Terminal Equipment Directive.) Luxembourg: Office for Official Publications of the European Communities, 1999.



# British Standards Institution (BSI)

BSI is the national body responsible for preparing British Standards and other standards-related publications, information and services.

BSI is incorporated by Royal Charter. British Standards and other standardization products are published by BSI Standards Limited.

## About us

We bring together business, industry, government, consumers, innovators and others to shape their combined experience and expertise into standards-based solutions.

The knowledge embodied in our standards has been carefully assembled in a dependable format and refined through our open consultation process. Organizations of all sizes and across all sectors choose standards to help them achieve their goals.

## Information on standards

We can provide you with the knowledge that your organization needs to succeed. Find out more about British Standards by visiting our website at [bsigroup.com/standards](http://bsigroup.com/standards) or contacting our Customer Services team or Knowledge Centre.

## Buying standards

You can buy and download PDF versions of BSI publications, including British and adopted European and international standards, through our website at [bsigroup.com/shop](http://bsigroup.com/shop), where hard copies can also be purchased.

If you need international and foreign standards from other Standards Development Organizations, hard copies can be ordered from our Customer Services team.

## Subscriptions

Our range of subscription services are designed to make using standards easier for you. For further information on our subscription products go to [bsigroup.com/subscriptions](http://bsigroup.com/subscriptions).

With **British Standards Online (BSOL)** you'll have instant access to over 55,000 British and adopted European and international standards from your desktop. It's available 24/7 and is refreshed daily so you'll always be up to date.

You can keep in touch with standards developments and receive substantial discounts on the purchase price of standards, both in single copy and subscription format, by becoming a **BSI Subscribing Member**.

**PLUS** is an updating service exclusive to BSI Subscribing Members. You will automatically receive the latest hard copy of your standards when they're revised or replaced.

To find out more about becoming a BSI Subscribing Member and the benefits of membership, please visit [bsigroup.com/shop](http://bsigroup.com/shop).

With a **Multi-User Network Licence (MUNL)** you are able to host standards publications on your intranet. Licences can cover as few or as many users as you wish. With updates supplied as soon as they're available, you can be sure your documentation is current. For further information, email [bsmusales@bsigroup.com](mailto:bsmusales@bsigroup.com).

## BSI Group Headquarters

389 Chiswick High Road London W4 4AL UK

## Revisions

Our British Standards and other publications are updated by amendment or revision.

We continually improve the quality of our products and services to benefit your business. If you find an inaccuracy or ambiguity within a British Standard or other BSI publication please inform the Knowledge Centre.

## Copyright

All the data, software and documentation set out in all British Standards and other BSI publications are the property of and copyrighted by BSI, or some person or entity that owns copyright in the information used (such as the international standardization bodies) and has formally licensed such information to BSI for commercial publication and use. Except as permitted under the Copyright, Designs and Patents Act 1988 no extract may be reproduced, stored in a retrieval system or transmitted in any form or by any means – electronic, photocopying, recording or otherwise – without prior written permission from BSI. Details and advice can be obtained from the Copyright & Licensing Department.

## Useful Contacts:

### Customer Services

**Tel:** +44 845 086 9001

**Email (orders):** [orders@bsigroup.com](mailto:orders@bsigroup.com)

**Email (enquiries):** [cservices@bsigroup.com](mailto:cservices@bsigroup.com)

### Subscriptions

**Tel:** +44 845 086 9001

**Email:** [subscriptions@bsigroup.com](mailto:subscriptions@bsigroup.com)

### Knowledge Centre

**Tel:** +44 20 8996 7004

**Email:** [knowledgecentre@bsigroup.com](mailto:knowledgecentre@bsigroup.com)

### Copyright & Licensing

**Tel:** +44 20 8996 7070

**Email:** [copyright@bsigroup.com](mailto:copyright@bsigroup.com)



...making excellence a habit.™