

Valves for waterworks purposes —

**Part 2: Stem caps for use on isolating
valves and associated water control
apparatus — Specification**

ICS 23.060.30

Committees responsible for this British Standard

The preparation of this British Standard was entrusted by Technical Committee PSE/7, Industrial valves, to Subcommittee PSE/7/3, Cast iron isolating, check and hydrant valves for industrial use and valves for water industry applications, upon which the following bodies were represented:

British Chemical Engineering Contractors Association
BVAA — British Valve and Actuator Association
CMF — Cast Metals Federation
Ductile Iron Producers Association
Energy Industries Council
Institution of Mechanical Engineers
Pipeline Industries Guild
Society of British Water Industries
Water UK

This British Standard was published under the authority of the Standards Policy and Strategy Committee on 23 December 2004

© BSI 23 December 2004

First published October 1974
First revision October 1986
First published as Part 2 December 2004

Amendments issued since publication

Amd. No.	Date	Comments

The following BSI references relate to the work on this British Standard:

Committee reference PSE/7/3
Draft for comment 04/30111467 DC

Contents

	Page
Committees responsible	Inside front cover
Foreword	ii
<hr/>	
1 Scope	1
2 Normative references	1
3 Terms and definitions	1
4 Design requirements	3
5 Preparing for storage and transport	4
<hr/>	
Annex A (normative) Test method for the resistance of stem caps to operating loads	5
<hr/>	
Bibliography	7
<hr/>	
Figure 1 — Ring key and bar	2
Figure 2 — T key	3
Figure 3 — Typical stem cap	4
<hr/>	
Table 1 — Dimensions of stem caps	3
<hr/>	

Foreword

This part of BS 5163 has been prepared under the direction of Technical Committee PSE/7 to facilitate the application of BS EN 1074-1:2000, BS EN 1074-2:2000 and BS EN 1074-6:2004. Along with BS 5163-1:2004, BS EN 1074-1:2000 and BS EN 1074-2:2000, this standard supersedes BS 5163:1986, which is withdrawn.

This standard gives details of stem caps not covered in BS EN 1074-1:2000, BS EN 1074-2:2000 or BS EN 1074-6:2004.

This publication does not purport to include all the necessary provisions of a contract. Users are responsible for its correct application.

Compliance with a British Standard does not of itself confer immunity from legal obligations.

Summary of pages

This document comprises a front cover, an inside front cover, pages i and ii, pages 1 to 7 and a back cover.

The BSI copyright notice displayed in this document indicates when the document was last issued.

1 Scope

Isolating valves and hydrants installed in underground pipelines primarily carrying water intended for human consumption within the United Kingdom are required to be fitted with a stem cap to enable them to be operated by a ring-key and bar or T-shaped key.

The stem cap is fitted to the top of the valve stem to convert the manufacturer's stem configuration to mate with operating keys.

Two sizes of stem cap are specified, covering respectively, valves from DN 50 through DN 300 and DN 350 through DN 600.

NOTE Stem caps are also commonly used on other waterworks apparatus, e.g. penstocks (specified in BS 7775).

2 Normative references

The following referenced documents are indispensable for the application of this document. For dated references, only the edition cited applies. For undated references, the latest edition of the referenced document (including any amendments) applies.

BS 6615:1996/ISO 8062:1994, *Specification for dimensional tolerances for metal and metal alloy castings*.

BS EN 1074-1, *Valves for water supply — Fitness for purpose requirements and appropriate verification tests — Part 1: General requirements*.

BS EN 1074-2, *Valves for water supply — Fitness for purpose requirements and appropriate verification tests — Part 2: Isolating valves*.

BS EN 1074-6, *Valves for water supply — Fitness for purpose requirements and appropriate verification tests — Part 6: Hydrants*.

BS EN 1503-3, *Valves — Materials for bodies, bonnets and covers — Part 3: Cast irons specified in European Standards*.

3 Terms and definitions

For the purposes of this part of BS 5163, the following terms and definitions apply.

3.1

stem cap

device to enable valves of different sizes and stem configurations to be operated by standard operating keys

NOTE 1 A stem cap is an operating element. See also BS EN 736-2.

NOTE 2 The socket end of operating keys should be dimensionally in accordance with BS 336 for valves up to DN 300.

3.2

ring key and bar

operating key with a socket at its lower end, which engages with the stem cap on the valve or hydrant, and a ring at the upper end to enable a bar to be inserted, which can then be used manually to turn the valve stem

NOTE A ring key and bar is illustrated in Figure 1.

3.3

T key

operating key similar to a ring key and bar but having a fixed short-length upper bar attached centrally at right angles to the shaft

NOTE A T key is illustrated in Figure 2.

3.4
mST
minimum strength torque as specified in BS EN 1074-1, BS EN 1074-2 and BS EN 1074-6

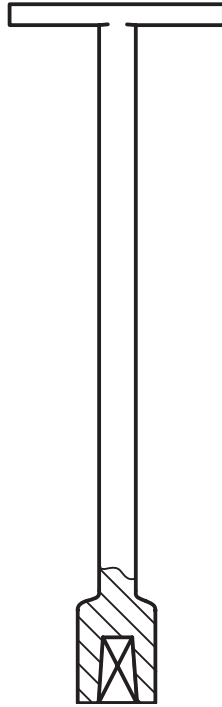

NOTE This sketch is diagrammatic only.

Figure 1 — Ring key and bar

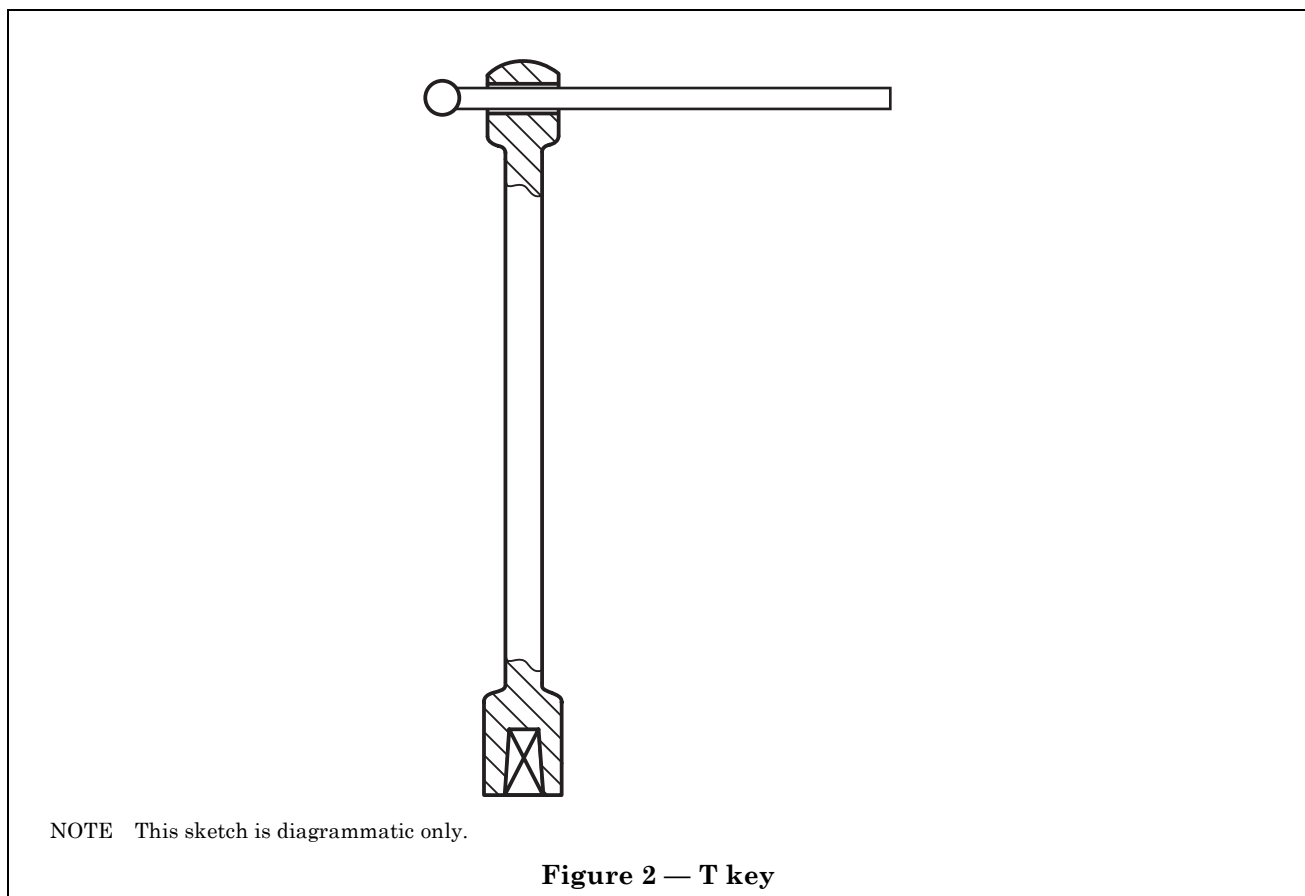

4 Design requirements

4.1 Materials

4.1.1 Stem cap materials shall be selected from those listed in BS EN 1503-3.

4.1.2 Cast iron components shall be fully coated to provide protection against corrosion.

4.1.3 Components used to secure stem caps to valve stems shall be resistant to corrosion and ageing by the selection of materials, or shall be protected by appropriate means.

4.2 Dimensions

4.2.1 Stem caps shall comply with the dimensions given in Table 1 and Figure 3. They shall be securely attached to the valve stem and be designed in such a manner that they can be removed when required. The method of attachment to the valve stem shall not interfere with the location of the operating key.

Table 1 — Dimensions of stem caps (see Figure 3)

Nominal size DN	Length of cap square, A mm	Square of cap, B mm
50, 65, 80, 100, 125, 150, 200, 250, 300	63	35
350, 400, 450, 500, 600	75	48
Dimensions A and B shall have casting tolerance ISO 8062-CT10 (BS 6615:1996/ISO 8062:1994).		
NOTE For sizes above DN 600, if a stem cap is required, dimensions should be agreed between purchaser and manufacturer.		

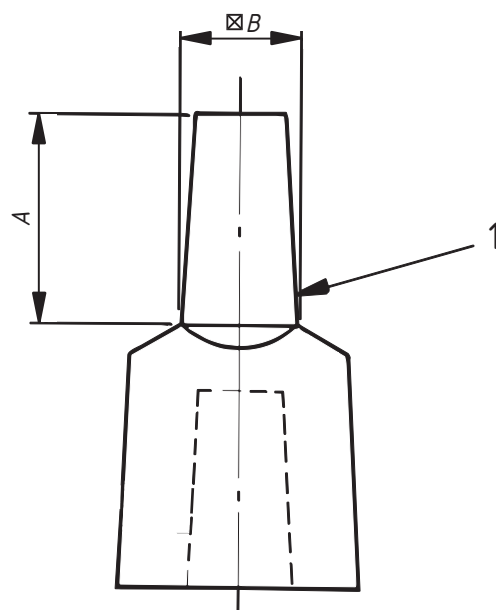
**Key**

- 1 Taper 1 in 20 on each side
- A Length of cap square (see Table 1)
- B Square of cap (see Table 1)

Figure 3 — Typical stem cap

4.2.2 The design of the lower end internal parts of the stem caps is the responsibility of the valve manufacturer, who shall ensure they can be secured to their design of stems and removed as required. The design shown in Figure 3 is typical only.

4.3 Resistance of stem caps to operating loads

Stem caps in their delivery condition shall withstand, without failure, an operating torque of 0.8 times the mST.

Failure is defined as the inability of the stem cap to resist the load for the duration of the test.

Testing shall be in accordance with Annex A.

5 Preparing for storage and transport

Stem caps can be supplied loose for use as spares, however, when supplied fitted to valves, they shall be securely fastened to the valve stem.

NOTE Care is required in handling valves on which a stem cap is fitted. In particular, valves should not be lifted by the stem cap to avoid the possibility of the valve and stem cap separating, causing both a health and safety risk and the possibility of damage to the valve.

Annex A (normative)

Test method for the resistance of stem caps to operating loads

A.1 General

The test shall be performed at ambient temperature with a stem cap in its delivery condition.

A.2 Test procedure

Attach and secure the stem cap on a rigidly mounted spigot having the same form and dimensions as the mating section of the valve stem. Apply a torque load as specified in 4.3 for a minimum of 15 s.

NOTE The socket used to apply the load should be dimensionally in accordance with BS 336 up to DN 300.

Bibliography

BS 336, *Specification for fire hose couplings and ancillary equipment.*

BS 7775, *Specification for penstocks.*

BS EN 736-2, *Valves — Terminology — Part 2: Definition of components of valves.*

BSI — British Standards Institution

BSI is the independent national body responsible for preparing British Standards. It presents the UK view on standards in Europe and at the international level. It is incorporated by Royal Charter.

Revisions

British Standards are updated by amendment or revision. Users of British Standards should make sure that they possess the latest amendments or editions.

It is the constant aim of BSI to improve the quality of our products and services. We would be grateful if anyone finding an inaccuracy or ambiguity while using this British Standard would inform the Secretary of the technical committee responsible, the identity of which can be found on the inside front cover. Tel: +44 (0)20 8996 9000. Fax: +44 (0)20 8996 7400.

BSI offers members an individual updating service called PLUS which ensures that subscribers automatically receive the latest editions of standards.

Buying standards

Orders for all BSI, international and foreign standards publications should be addressed to Customer Services. Tel: +44 (0)20 8996 9001. Fax: +44 (0)20 8996 7001. Email: orders@bsi-global.com. Standards are also available from the BSI website at <http://www.bsi-global.com>.

In response to orders for international standards, it is BSI policy to supply the BSI implementation of those that have been published as British Standards, unless otherwise requested.

Information on standards

BSI provides a wide range of information on national, European and international standards through its Library and its Technical Help to Exporters Service. Various BSI electronic information services are also available which give details on all its products and services. Contact the Information Centre. Tel: +44 (0)20 8996 7111. Fax: +44 (0)20 8996 7048. Email: info@bsi-global.com.

Subscribing members of BSI are kept up to date with standards developments and receive substantial discounts on the purchase price of standards. For details of these and other benefits contact Membership Administration. Tel: +44 (0)20 8996 7002. Fax: +44 (0)20 8996 7001. Email: membership@bsi-global.com.

Information regarding online access to British Standards via British Standards Online can be found at <http://www.bsi-global.com/bsonline>.

Further information about BSI is available on the BSI website at <http://www.bsi-global.com>.

Copyright

Copyright subsists in all BSI publications. BSI also holds the copyright, in the UK, of the publications of the international standardization bodies. Except as permitted under the Copyright, Designs and Patents Act 1988 no extract may be reproduced, stored in a retrieval system or transmitted in any form or by any means – electronic, photocopying, recording or otherwise – without prior written permission from BSI.

This does not preclude the free use, in the course of implementing the standard, of necessary details such as symbols, and size, type or grade designations. If these details are to be used for any other purpose than implementation then the prior written permission of BSI must be obtained.

Details and advice can be obtained from the Copyright & Licensing Manager. Tel: +44 (0)20 8996 7070. Fax: +44 (0)20 8996 7553. Email: copyright@bsi-global.com.