

Mining type flameproof supply and control units for use systems up to 1100 V —

**Part 4: Specification for air-cooled
transformers to power drilling
machines**

Confirmed
January 2011

Committees responsible for this British Standard

The preparation of this British Standard was entrusted by the Mining Requisites Standards Policy Committee (MRE/-) to Technical Committee MRE/16, upon which the following bodies were represented:

Association of British Mining Equipment Companies
British Coal Corporation
Health and Safety Executive

This British Standard, having been prepared under the direction of the Mining Requisites Standards Policy Committee, was published under the authority of the Standards Board and comes into effect on 15 December 1993

© BSI 09-1999

First published November 1982
Second edition December 1993

The following BSI references relate to the work on this standard:
Committee reference MRE/16
Draft for comment 92/76105 DC

ISBN 0 580 22424 4

Amendments issued since publication

Amd. No.	Date	Comments

Contents

	Page
Committees responsible	Inside front cover
Foreword	ii
<hr/>	
1 Scope	1
2 References	1
3 Definitions	1
4 Information and requirements to be agreed and to be documented	2
5 Service conditions	2
6 Rated values	3
7 Design and construction	3
8 Verification and tests	9
9 Marking	10
<hr/>	
Figure 1 — Outline of enclosures showing arrangements for earthing terminals and skid couplings	11
Figure 2 — Busbar chamber end flange	12
Figure 3 — Busbar interconnecting trunk with cover plate	13
Figure 4 — 650/1 100 V busbar interconnecting adaptor trunk	14
Figure 5 — 650/1 100 V skid coupling plate	15
Figure 6 — End cover for busbar chamber	16
Figure 7 — Example of outgoing cable fittings	17
Figure 8 — Envelope dimensions for padlocks	18
<hr/>	
Table 1 — Creepage distance and clearance	8
<hr/>	
List of references	20
<hr/>	

Foreword

This Part of BS 5126 has been prepared under the direction of the Mining Requisites Standards Committee. It supersedes BS 5126-4:1982, which is withdrawn. This revision updates the standard to reflect today's usage for 1 100 V mining type flameproof supply and control units (commonly known in the UK as "gate-end boxes") and takes account of expected future development.

This Part of BS 5126 covers units in which the essential apparatus are air-cooled transformers to power drilling machines, whilst Parts 1, 2 and 3 cover direct-on-line motor starter units, circuit breaker units, and lighting transformer units, respectively. All have standard busbar and other fixing dimensions, enabling the different units to be fastened together to form a switchboard.

This standard is arranged to be in close alignment with IEC (International Electrotechnical Commission) criteria for various electrical features.

A British Standard does not purport to include all the necessary provisions of a contract. Users of British Standards are responsible for their correct application.

Compliance with a British Standard does not of itself confer immunity from legal obligations. Attention is drawn to the Health and Safety at Work etc. Act 1974 [1], the Mines and Quarries Act 1954 [2], the Regulations made under these Acts, and also any other appropriate statutory requirements or byelaws. These place responsibility for complying with certain specific safety requirements on the manufacturer and the user. The addresses of the recognized certification authorities in the United Kingdom for Group I (Mines susceptible to firedamp) apparatus are:

Health and Safety Executive
Mining Equipment Certification Service
Harpur Hill, Buxton, Derbyshire, SK17 9JN

SIRA Certification Service
Saighton Lane
Saighton
Chester CH3 6EG

Summary of pages

This document comprises a front cover, an inside front cover, pages i and ii, pages 1 to 20, an inside back cover and a back cover.

This standard has been updated (see copyright date) and may have had amendments incorporated. This will be indicated in the amendment table on the inside front cover.

1 Scope

This Part of BS 5126 specifies requirements for flameproof supply and control units designed primarily for use in the coal mining industry on 1 100 V three-phase a.c. circuits containing three-phase transformers intended for supplying electrically operated drilling machines. Provision is also made for operation on other voltages, where required.

In addition to the definitive requirements, this standard also requires the items detailed in clause 4 to be documented. For compliance with this standard, both the definitive requirements and the documented items have to be satisfied.

NOTE 1 To facilitate cross-reference and subject location recall between the Parts of this standard, a uniformity of clause arrangements is maintained. At subclause level, because of the different purposes and individual technical features of the four types of control unit, some differences in title and/or subclause arrangements have been unavoidable, but have been made without disturbing the general pattern.

NOTE 2 The figures in this standard show only those features and dimensions essential for function and interchangeability. Dimensions are in millimetres. Untoleranced values less than 100 mm are ± 0.15 mm and those greater than 100 mm are ± 0.25 mm.

2 References

2.1 Normative references

This Part of BS 5126 incorporates, by reference, provisions from specific editions of other publications. These normative references are cited at the appropriate points in the text and the publications are listed on page 20. Subsequent amendments to, or revisions of, any of these publications apply to this Part of BS 5126 only when incorporated in it by updating or revision.

2.2 Informative references

This Part of BS 5126 refers to other publications that provide information or guidance. Editions of these publications current at the time of issue of this standard are listed on the inside back cover, but reference should be made to the latest editions.

3 Definitions

For the purposes of this Part of BS 5126, the following definitions apply¹⁾.

3.1

supply and control unit (gate-end box)

a flameproof enclosure containing electrical apparatus, such as transformer, control gear, switchgear and or protective gear, designed primarily for use underground

NOTE 1 In this Part of BS 5126, the term "unit" has in many instances been used in abbreviation of "supply and control unit".

NOTE 2 For the purposes of this Part of BS 5126, the enclosed apparatus is essentially a three-phase air-cooled transformer with associated equipment to provide a supply for drilling and other similar low voltage machines.

3.2

switch disconnecter (isolating switch)

a switch which isolates a circuit and is capable of breaking not less than its rated current at rated voltage

3.3

cable half coupler (flit plug)

a detachable cable sealing box utilizing contact tubes and pins to facilitate ready connection to, or disconnection from, a similar unit or other apparatus

3.4

cable coupler adaptor

a device used to connect either a cable half coupler or other type of cable termination to apparatus. If used to connect a cable half coupler it may either be separate from, or be integral with, the enclosure of the apparatus

3.5

cable sealing box

a device designed to receive and protect the end of the cable, with provision for sealing the conductors and the insulating material of the cable with a filling compound and having a cable gland for attaching the cable to the box, together with any terminals provided for connection to the conductors of the cable within the box. The box may form part of, or be detachable from, the apparatus with which it is associated

3.6

detachable cable sealing box

a cable sealing box which can be detached from associated apparatus without disturbing the sealing of the cable

3.7

restrained plug and socket

a plug and socket in which the two portions are engaged, retained and disengaged by means of a manually operated device

3.8

bolted cable plug and socket

a plug and socket designed to be held together by two or more bolts or screws, or studs and nuts, in such a way that the plug cannot be disengaged from the socket without the use of a tool

¹⁾ The terms in brackets are those commonly used in practice.

3.9 overcurrent protection

a device that causes the circuit being protected to be automatically disconnected from the supply when the current exceeds a predetermined value

NOTE The preferred term “overcurrent” is used throughout this standard, but in certain other British Standards to which reference is made the term “overload” may be used when referring to these devices.

3.10 instantaneous short circuit protection

a device that causes the circuit being protected to be automatically disconnected from the supply without intentional time delay when the current exceeds a predetermined value

4 Information and requirements to be agreed and to be documented

4.1 Information to be supplied by the purchaser

The following information to be supplied by the purchaser shall be fully documented. Both the definitive requirements specified throughout the standard and the following documented items shall be satisfied before a claim of compliance with the standard can be made and verified.

- a) the number and date of this British Standard, i.e. BS 5126-4:1993;
- b) the service conditions, if other than those specified in clause 5;
- c) information relating to the drill/motor to be controlled, where known:
 - 1) full load current or rated output of the drill/motor in kilowatts;
 - 2) any information concerning special conditions likely to affect the performance of the transformer and contactor;
- d) any information concerning special conditions likely to affect the performance of the unit;
- e) the voltage, if less than 1 100 V (see 6.1);
- f) the rated frequency of the supply system and its deviation if greater than ± 2 Hz (see 6.2);
- g) the no-load output voltage (see 6.3);
- h) the rated kilovolt-ampere output (see 6.4);
- i) the rated thermal current of busbars (see 6.5);
- j) whether two or more units are to be coupled together (see 7.4);
- k) whether provision for incoming and throughgoing cable fittings is required at one or both ends of the unit, and the type of fitting required (see 7.6.1);

l) the type of outgoing cable fittings, together with the number, if any, of the auxiliary cable fittings needed; the control and interlock circuit for the restrained plug and socket of the outgoing cable, if other than one conforming to BS 3101:1986 and BS 7202:1989 (see 7.6.2);

m) whether secondary means of isolation are to be fitted (see 7.8.2);

n) whether any auxiliary circuits are to be connected across the power circuit (see 7.10.4);

o) live compartment indication in the switch disconnect chamber (see 7.14);

p) whether voltage-free auxiliary contacts are to be fitted and whether they are to be used for control (see 7.21);

q) the testing authority for type tests, if other than the manufacturer (see 8.1.2);

r) the certifying authority, if other than a UK authority (see foreword).

4.2 Items to be agreed between the contracting parties

The following items to be agreed between the contracting parties, which are specified in the clauses referred to, shall be fully documented. Both the definitive requirements specified throughout the standard and the following documented items shall be satisfied before a claim of compliance with the standard can be made and verified.

- a) additional protection to take account of overloading (see 7.10.1.1 and 7.10.1.3);
- b) whether earth fault electrical lockout is to be fitted (see 7.10.3);
- c) pilot-to-earth test facility (see 7.10.6);
- d) the form of control, if other than specified in 7.11;
- e) provision of a test feature (see 7.14.2);
- f) the terminals to be marked and the information to be displayed (see 9.2);
- g) the form of the diagrams (see 9.5).

5 Service conditions

Within the limits of their ratings, units shall be suitable for use in installations operating under the intended service conditions. Unless otherwise specified by the purchaser [see 4.1 b)], these service conditions shall be not more severe than the following.

- a) *Ambient temperature*: a peak value not exceeding 40 °C with an average value not exceeding 35 °C over 24 h periods. The lower limit of the ambient temperature is – 5 °C.
- b) *Altitude*: an altitude at the site of installation not exceeding 2 000 m (6 600 ft.) above sea-level.

6 Rated values

6.1 Supply voltage

The maximum rated supply voltage shall be 1 100 V. Units shall operate normally within the limits $- 10\%$ and $+ 6\%$ of the declared rated supply voltage.

Voltages less than 1 100 V shall be specified by the purchaser [see 4.1 e)].

6.2 Supply frequency

Units shall have a rated supply frequency within the range 40 Hz to 62 Hz.

The purchaser shall state the supply frequency required, and its deviation if greater than ± 2 Hz, on the enquiry and/or order [see 4.1 f)].

NOTE The standard frequency is 50 Hz. The normal deviation is not greater than ± 2 Hz.

6.3 Output voltage

Unless otherwise specified by the purchaser [see 4.1 g)], the rated no-load output voltage shall be 125 V.

6.4 Kilovolt-ampere output

Unless otherwise specified by the purchaser [see 4.1 h)], the rated kilovolt-ampere output shall be one of the following:

- a) 1.25 kV A for single circuit units;
- b) 2.5 kV A for double circuit units.

6.5 Thermal current of busbars

Unless otherwise specified by the purchaser [see 4.1 i)], the rated thermal current of busbars shall be one of the following:

- a) 300 A;
- b) 400 A.

7 Design and construction

7.1 General

The flameproof parts of a unit supplied in accordance with this standard shall conform to one of the following standards:

- a) BS 4683-2:1971;
- b) BS 5501-5:1977;
- c) BS 6709:1986;

for Group I enclosures, with fittings in accordance with 7.4, 7.5 and 7.6. However, units designed and certified before the date of publication of this standard, which have been certified as flameproof in accordance with BS 229 for Group I gas (methane/firedamp), shall be deemed to conform to this standard provided that the requirements of all other clauses are met.

The design and construction of units shall minimize the risk of inadvertent closure of relays or contactors arising from either:

- 1) pressure changes within the enclosure; or
- 2) changes in the parameters of electronic components or programmable electronic systems due to variations in temperature or electrical interference.

Any circuits required to be intrinsically safe shall conform to BS 1259:1958 appropriate to Class 1, or BS 5501-7:1977 appropriate to Group I.

NOTE 1 Where a unit conforming to this standard and to BS 5501 is to be directly connected to apparatus conforming to BS 229 or BS 1259 or BS 4683, it may be necessary to construct the unit such that it conforms to BS 6709.

NOTE 2 Where a unit is not to be connected as in note 1, in order to promote the increasing use of BS 5501 in parallel with the progressive phasing out of Group I apparatus conforming to earlier standards, such a unit should conform to BS 5501.

The material for external components and enclosures shall be one of the following:

- a) a corrosion resistant ferrous alloy; or
- b) a non-ferrous metal, other than aluminium, magnesium or titanium; or
- c) an alloy containing the metals aluminium, magnesium, titanium, either singly or in combinations, providing that the total content of these three constituents does not exceed 15 % (*m/m*) of the alloy and the combined content of magnesium and titanium does not exceed 6 % (*m/m*) of the alloy.

NOTE 3 These limitations have been imposed to avoid the hazards of incendive sparking due to friction between rusted steel or iron and the metals listed.

7.2 Supply and control unit assembly

NOTE A supply and control unit comprises a basic unit together with optional features.

The basic unit shall conform to the following:

- | | |
|---------------|---|
| 7.3 | for the enclosing case |
| 7.6.2 | for the fittings for the outgoing cable |
| 7.7 | for busbars |
| 7.8.1 | for the means of isolation (primary) |
| 7.8.3 | for the means of reversing |
| 7.9 | for the transformer |
| 7.10.1 | for overcurrent and short circuit protection |
| 7.10.2 | for earth fault protection for main outgoing conductors |
| 7.10.5 | for undervoltage protection |
| 7.11 | for provision for control |
| 7.12 | for external control devices |
| 7.13 | for provision for earthing |
| 7.14 | for contactors |
| 7.16 | for live compartment indication in the main chamber |
| 7.18 | for internal protective cover |

Where supplied, the optional features shall conform to the following:

- 7.4 for coupling of units
- 7.5 for busbar end cover
- 7.6.1 for the fittings for the incoming and throughgoing cables
- 7.8.2 for the means of isolation (secondary)
- 7.10.1.3 for outgoing circuit protection
- 7.10.3 for the earth fault electrical lockout for outgoing main conductors
- 7.10.4 for auxiliary circuit protection
- 7.10.6 pilot-to-earth fault protection and test facility
- 7.14.2 for the test feature
- 7.15 for selection and indication of secondary voltage
- 7.16 for live compartment indication in the switch disconnecter chamber
- 7.21 for voltage-free auxiliary contact

The supply and control unit, i.e. the basic unit plus the optional features, shall conform to the following:

- 7.17 for temperature limits
- 7.19 for creepage distance and clearance
- 7.20 for insulating material

7.3 Enclosing case

The enclosing case shall comprise a main chamber and a switch disconnecter busbar chamber, each with access covers. It shall be equipped with lifting points and shall incorporate, or be adapted for mounting on, skids to facilitate transport (see Figure 1).

The design shall include such provision as will permit, without structural alteration, the attachment of adaptors, cable fittings, interconnecting trunks, etc. as specified in 7.4, 7.5 and 7.6, in any combination that may be required for normal installation and operation of the unit. The busbar coupling flange shall conform to the dimensions and tolerances shown in Figure 2.

7.4 Coupling of units

The purchaser shall state on the enquiry and/or order [see 4.1 j)] whether two or more units are to be coupled together. When this is required interconnecting busbar trunking shall be fitted. The interconnecting busbar trunk shall conform to Figure 3.

Where an 1 100 V unit having a busbar chamber end flange as shown in Figure 1 is to be used for operation on a system voltage of up to 650 V, and is to be coupled to a unit having a busbar chamber end flange as shown in Figure 1 of BS 787-1:1969, a busbar interconnecting adaptor trunk as shown in Figure 4 shall be fitted.

Where busbar trunking is used to connect two units together, means shall be provided as shown in Figure 1. Where a trunk as shown in Figure 4 is used, the coupling plate shown in Figure 5 shall be used.

NOTE 1 The coupling arrangements need to be sufficiently robust to prevent, in normal use, undue strain being placed on the flanges of the unit or those of the interconnecting busbar trunking.

NOTE 2 Where skids are provided, it is usual either for the skids to be continuous or, where individual skids are fitted, for coupling plates to be bolted between the skids.

NOTE 3 In some designs the bottom of the enclosing case can be utilized as an individual skid.

7.5 Busbar end cover

Where cable attachments conforming to 7.6.1 or couplings conforming to 7.4 are not used, an end cover as shown in Figure 6 shall be fitted to complete the enclosure.

7.6 Fittings for cables

7.6.1 Incoming and throughgoing cable

The busbar chamber shall be fitted with a means of attaching incoming or throughgoing cables. The purchaser shall state on the enquiry and/or order whether provision for the fittings is required at one or both ends of the unit and which of the following types is to be used [see 4.1 k)]:

- a) an adaptor for the reception of a cable half coupler, e.g. as specified in BS 3454;
- b) a compound filled detachable cable sealing and dividing box;

NOTE A suitable compound should conform to BS 7383.

- c) any other fitting which is acceptable to the certifying authority²⁾.

The cable details shall be given by the purchaser in accordance with the appropriate British Standard.

7.6.2 Outgoing cable

For the attachment of the outgoing cable, the case of the unit shall be fitted with sockets for the reception of suitable plugs which, when combined, form plug and socket couplings.

²⁾ See foreword.

The purchaser shall state on the enquiry and/or order whether these shall be of the restrained or bolted types, together with the number, if any, of the auxiliary cable fittings needed [see 4.1 l)]. The cable details shall be given in accordance with the appropriate British Standard. The fittings shall be constructed and mounted so that the properties of the flameproof enclosure of the unit are maintained, even when the plug is separated from the socket.

Restrained plugs and sockets shall be such that the properties of the flameproof enclosure they form are maintained in the event of internal explosion, both when the plug and socket are connected together and at the moment of separation of the contacts, other than those for earthing or those which are in non-incendive circuits.

An electrical control and interlock circuit shall be provided. The contacts used for electrical interlocking of the restrained plug shall make after, and break before, the main contacts when engaging or disengaging the plug.

Unless the purchaser specifies otherwise on the enquiry and/or order [see 4.1 l)], this shall conform to BS 3101:1986 and BS 7202:1989 and shall be provided with pilot-to-earth fault protection, (see 7.10.6).

Although fittings for outgoing cables may be mounted on the switch disconnecter/busbar chamber, for flameproofing purposes they shall be part of the main chamber. They shall be mounted on the unit in a horizontal plane at the least angle so as to clear point "X" in the example shown in Figure 7.

7.7 Busbars

Three throughgoing busbars conforming to the temperature rise requirements of BS 5486-2:1988 shall be fitted.

NOTE It is recognized that BS 5486-2:1988 relates to units up to 1 000 V a.c., but the requirements specified therein are applicable when the units are used at their maximum operating voltage of 1 100 V.

7.8 Means of isolation

7.8.1 Means of isolation (primary)

A switch disconnecter breaking all phases of the supply shall be provided in the busbar chamber, having a continuous current rating of either 15 A or the current rating of the largest transformer that is fitted in the unit, whichever is the greater. It shall not be possible to open the main chamber unless the switch disconnecter is in the OFF position, or to close the switch disconnecter while the main chamber is open.

The switch disconnecter shall conform to category AC-22A of BS EN 60947-3:1992 with respect to:

- the verification of rated making and breaking capacity;
- electrical endurance;
- the rated short time withstand current, the value of which shall be not less than the cut-off current of the primary circuit fuse.

The operating handle shall be at the front of the unit and the ON and OFF positions shall be clearly indicated. Provision shall be made for locking the handle in the OFF position, and the arrangement shall be capable of accommodating any padlock having dimensions within the envelope shown in Figure 8. External devices shall be provided to prevent movement of the switch disconnecter handle to such a position as would cause internal damage.

For mechanical endurance all moving parts of the switch disconnecter and any auxiliary contacts or mechanical interlocks operated by the movement of the switch disconnecter shall be capable of 3 000 no-load operating cycles.

NOTE It is recognized that BS EN 60947-3:1992 relates to switches, disconnecters and fuse combination units up to 1 000 V a.c., but the duty ratings and tests therein specified are applicable when units are used at their maximum rated operating voltage of 1 100 V.

7.8.2 Means of isolation (secondary)

The purchaser shall state on the enquiry and/or order whether secondary means of isolation are to be fitted [see 4.1 m)].

NOTE Where fitted, a suitably rated triple pole ON/OFF isolating switch or circuit breaker with external operating handle capable of being locked in the OFF position, may be provided to isolate separately each outgoing circuit.

Where fitted, the locking arrangement shall be capable of accommodating any padlock having dimensions within the envelope shown in Figure 8.

7.8.3 Means of reversing

Means shall be provided, without opening the enclosure, for separately reversing the phase rotation of each outgoing circuit.

7.9 Transformer

The transformer shall be of the three-phase double-wound "AN" type conforming to BS 171-1:1978 and BS 171-2:1978 and shall have a continuous rating conforming to the declared kilovolt-ampere output (see 6.4), when enclosed in the case.

The transformer windings shall conform to the voltage requirements of clause 6.4.

NOTE A separate secondary three-phase winding for each output circuit is preferred but a single 2.5 kV. A continuously rated winding for double output circuits is considered to meet the requirements of this standard.

The neutral point of the transformer secondary winding shall be brought out and connected to earth through a current limiting device (see 7.10.2) and a removable link to facilitate testing, one side of the link having a direct connection to an earthing terminal. No automatic circuit breaker or fuse shall be placed in this connection to earth.

All connections shall be brought to readily accessible terminals which shall be clearly marked to indicate the voltage with which they are associated.

7.10 Protection

7.10.1 Overcurrent and short circuit protection

7.10.1.1 General

Protection shall be provided in accordance with 7.10.1.2 and 7.10.1.3. Any additional protection provided to take account of overloading due to starting, running and cyclic operation shall be agreed between the supplier and purchaser [see 4.2 a)].

7.10.1.2 Primary circuit protection

A suitably rated fuse conforming to BS 2692-1:1986 and capable of breaking a prospective fault current of at least 12 kA at 1 100 V shall be provided in the main chamber in each supply lead to the transformer primary winding.

Wiring used to connect fuses to the power circuit shall be capable of withstanding the cut-off current of the fuse.

NOTE 1 Wiring between the power circuits and fuses should be kept as short as practicable and arranged so as to minimize risk of short circuit, either by providing additional insulation and/or by enhanced segregation.

All primary side wiring and connections shall be capable of continuously carrying the minimum current required to rupture the protective fuse provided.

NOTE 2 This minimum current is normally 1.6 times the fuse rating.

7.10.1.3 Outgoing circuit protection

Overcurrent protection shall be provided in each outgoing circuit by the fitting of overcurrent releases in at least two phases which, on operation, shall cause the contactor to open. The protection shall conform to the relevant requirements of type 1 of BS EN 60947-4-1:1992 and shall be of the inverse time lag overcurrent release type suitable for motor starting currents for a range of duties up to the full load continuous rating of the unit. Where this requirement cannot be met with one device, a range of readily replaceable devices shall be available.

The range of settings covered by the overcurrent device shall be marked either in amperes, or in such a manner that the setting in amperes can be readily determined.

Any additional protection provided to take account of overloading due to starting, running and cyclic operation shall be agreed between the supplier and purchaser [see 4.2 a)].

7.10.2 Earth fault protection for outgoing main conductors

Earth fault protection shall be provided. The impedance of the circuit connecting the midpoint of the secondary winding of the drill transformer to earth shall limit the prospective, earth fault current to not more than 250 mA.

The earth fault protection shall operate to disconnect the supply from the outgoing defective circuit(s) when the earth fault current attains a value not exceeding 8 % of the prospective earth fault current.

NOTE The 8 % value is chosen to allow use of a cable having a conducting elastometric screen, e.g. type 43 conforming to BS 6708.

The earth fault trip shall not be self-resetting. Means shall be provided to reset the protection without opening the enclosures and shall prevent resetting by unauthorized persons.

Visible indication of earth fault trip shall be provided.

It shall be possible for an authorized person, without opening the enclosure, to test that the protection functions correctly. Additionally, the test circuit shall be arranged to prove that the removable link between the secondary winding and the earth is connected in circuit.

7.10.3 Earth fault electrical lockout for outgoing main conductors

Unless otherwise agreed between the supplier and purchaser [see 4.2 b)], earth fault electrical lockout shall be fitted. Where it is fitted, means shall be provided to prevent the reconnection of any outgoing circuit to the supply whilst an earth fault exists. Any monitoring circuit for this purpose shall conform to BS 7202:1989.

The earth fault electrical lockout shall not reset if the impedance between the outgoing circuit conductors and earth is less than that which would cause the earth fault protection to operate.

Earth fault electrical lockout shall not be self-resetting. Means shall be provided to reset the protection without opening the enclosure and shall prevent resetting by unauthorized persons.

Visible indication of the earth fault electrical lockout shall be provided.

7.10.4 Auxiliary circuit protection

The purchaser shall specify any auxiliary circuits and/or instruments to be connected across the power circuit on the enquiry and/or order [see 4.1 n)]. Where auxiliary circuits and/or instruments are connected across the power circuit, they shall be protected by fuses conforming to BS 2692-1:1986 and shall have a breaking capacity of at least 12 kA at 1 100 V. All other fuses shall conform to BS 88-1:1988.

Wiring used to connect fuses to the power circuit shall be capable of withstanding the cut-off current of the fuse.

NOTE 1 Wiring between the power circuit and fuses should be kept as short as practicable and arranged so as to minimize risk of short circuit, either by providing additional insulation and/or by enhanced segregation.

All other auxiliary circuit wiring, contacts and connections shall be capable of continuously carrying the minimum current required to rupture the protective fuse provided.

NOTE 2 This minimum current is normally 1.6 times the fuse rating.

7.10.5 Undervoltage protection

Means shall be provided to ensure that the contactor opens when the supply voltage falls to the appropriate value specified in BS 60947-4-1:1992 (except where such value is modified by BS 3101:1986, where applicable) and does not reclose on the restoration of supply voltage up to 120 % of the rated voltage, except when the control is reset and a restart is initiated.

7.10.6 Pilot-to-earth fault protection and test facility

In the event of inadvertent contact between the pilot core and earth, provision shall be made to cause the contactor to open if in the closed position or not to close if in the open position.

Where agreed between supplier and purchaser [see 4.2 c)], means shall be provided at the unit to enable an authorized person, without opening the enclosure, to test the pilot-to-earth fault protection for correct function.

7.11 Provision for control

Unless otherwise agreed between the supplier and the purchaser [see 4.2 d)] each outgoing circuit shall conform to the interlock circuit requirements of BS 3101:1986 except that it shall be arranged for remote control from the drilling machine via the interlock circuit core and earth conductors in the drill cable.

NOTE Apparatus intended to be supplied from this unit should include suitable control arrangements, which in the case of drilling machines should be an ON/OFF switch spring-loaded to the OFF position.

7.12 External control devices

External handles, levers or push-buttons shall be arranged to minimize risk of inadvertent operation; also damage or distortion due to mishandling, falls of roof or collision with other gear. Where operating spindles pass through the wall of the enclosure, they shall be provided with a renewable bush.

7.13 Provision for earthing

An external earthing terminal, with brass nuts, not less in size than M12 conforming to BS 3692:1967, shall be provided to enable the containing case of the unit to be earthed, irrespective of any means provided for attaching the metallic covering of the cable feeding the apparatus.

7.14 Contactors

7.14.1 General

Each outgoing circuit shall be controlled by an electromagnetically operated triple-pole contactor conforming to BS EN 60947-4-1:1992, utilization category AC-4, intermittent duty class 1, mechanical endurance one million no-load operating cycles, the rated thermal load current of which shall be not less than 15 A.

Where the main contactor is controlled by a relay, the minimum values of incoming supply voltage at which a contactor shall pick-up and drop-off shall be less than the corresponding values of the relay.

The contactor shall operate satisfactorily when tilted in any direction at an angle of 15° to its normal operating position.

7.14.2 Test feature

Where agreed between the supplier and purchaser [see 4.2 e)], a test feature associated with the means of isolation shall be provided to allow operation of the contactor and the control circuit components in the main chamber without the outgoing power circuits being energized.

Where the test circuit originates from the busbars, separate back-up fuse protection shall be provided as close to the busbars as practicable.

7.15 Selection and indication of secondary voltage

When a unit is designed for dual-voltage operation, the preferred selection of secondary voltage shall be made internally. Means shall be provided to enable the selected voltage to be indicated externally.

7.16 Live compartment indication

Live compartment indication shall be provided in the main chamber and, when specified on the enquiry and/or order [see 4.1 o)], additionally in the switch disconnect chamber.

The indicator shall be a light emitting source either glowing in steady state or switching on and off at a rate of at least once per second and shall indicate the presence of incoming supply voltage on the main and auxiliary circuits. The illumination level of the indicator shall be such that it is visible externally from the front of the chamber(s).

Indicator circuits shall not be galvanically connected to the power conductors and every component used to reduce the supply voltage to the light emitting source shall have a rating of at least 1200 V.

NOTE Design of the live compartment indication should take into account the necessity for the equipment to be highly reliable and in addition should allow for easy replacement of parts.

7.17 Temperature limits

The temperature limits of individual components shall conform to the relevant British Standards when tested in accordance with those standards, i.e. BS 88-1:1988, BS 171-2:1978, BS 2692-1:1986, BS 5486-2:1988, BS EN 60947-3:1992 and BS EN 60947-4-1:1992.

Where the temperature of such a component in a fully assembled unit could exceed the temperature limit prescribed by its relevant British Standard, owing to the heating effect of other component(s), that component shall conform to all other specified performance requirements of this standard at the ratings assigned to it when incorporated in the fully assembled unit.

NOTE See clause 5 for service conditions.

7.18 Internal protective cover

Under each access cover to potentially live parts not isolated by the integral switch disconnecter isolator, there shall be a further protective cover which forms an enclosure having a minimum degree of protection IP 20 to BS EN 60529:1992 and bearing the following prominently displayed and permanently legible warning notice.

“DANGER — IS THE SUPPLY ISOLATED?”

This cover shall be so located that it has to be removed before contact can be made with potentially live parts.

Where the protective enclosure is constructed of a non-metallic material it shall conform to 7.20.

7.19 Creepage distance and clearance

The minimum clearance between live parts at different potentials, and between live parts and earth, shall be such that no flash-over occurs when the unit is tested in accordance with clause 9.

Where live parts connected to the mains supply pass from one flameproof compartment to another, the creepage distance and clearance in air between them and between live parts and earth, shall be not less than 32 mm and 25 mm, respectively. All other live parts shall conform to either a relevant product standard, or Table 1.

Table 1 — Creepage distance and clearance

Working voltage V	Creepage distance		Clearance mm
	CTI ^a > 600 mm	CTI ^a 400 to 600 mm	
15	1.6	1.6	1.6
30	1.8	1.8	1.8
60	2.1	2.6	2.1
110	2.5	3.2	2.5
175	3.2	4	3.2
275	5	6.3	5
420	8	10	6
550	10	12.5	8
750	12	16	10
1 100	20	25	14

^a Compliance tracking index (CTI), see BS 5901:1980.

Where live parts are connected to the mains supply, distances for line voltages shall also apply between live parts and earth.

No component shall be mounted, or wiring run in such a manner that the foregoing creepage distance or clearance is reduced.

7.20 Insulating material

Insulating material used in circuits operating all a voltage in excess of 250 V or carrying a current of more than 16 A shall have a comparative tracking index of not less than CTI 400 when tested in accordance with BS 5901:1980.

7.21 Voltage-free auxiliary contact

The purchaser shall state on the enquiry and/or order whether voltage-free auxiliary contacts are to be fitted for connection to external circuits and whether they are to be used for control [see 4.1 p)]. Where they are to be fitted, they shall be segregated in accordance with BS 5501-7:1977. Where they are to be used for control, they shall additionally be protected against inadvertent operation.

8 Verification and tests

8.1 General

8.1.1 The supplier of the unit shall make available to the purchaser all documentation to show that conformity to all requirements of this standard has been achieved.

NOTE 1 The documentation provided can be in the form of test reports, photographs, certificates of compliance, statements or guarantees, whether they be based on his own tests or third party tests (e.g. by a certification authority).

NOTE 2 It is not intended that all tests be carried out on every unit supplied. In some cases it may be pertinent to test a representative sample of the unit or its components for the purpose of verifying that the unit itself has been constructed so as to conform to this standard.

8.1.2 Two kinds of tests shall be recognized, as follows:

- a) type tests, which shall be made on a representative sample of each particular type of unit, and which shall be made by an agreed authority who may be the manufacturer, unless the purchaser specifies otherwise on the enquiry and/or order [see 4.1 q)];
- b) routine (individual tests), which shall be made on each unit manufactured to this standard.

8.2 Test requirements

8.2.1 General

Tests shall be made on a completely assembled unit in accordance with 8.2.2, 8.2.3 and 8.2.4 for both type and routine tests and also 8.2.5 for additional type tests and 8.2.6 for additional routine tests.

8.2.2 Switch disconnecter

Switch disconnectors shall be tested in accordance with BS EN 60947-3:1992, except that following completion of the mechanical endurance test given in 7.8.1, the disconnecter shall still conform to category AC-22A of BS EN 60947-3:1992.

8.2.3 Transformer

The transformer shall be tested in accordance with BS 171-1:1978 and BS 171-2:1978 insofar as the standard relates to a dry type air-cooled transformer enclosed in an air-cooled enclosure (type ANAN).

8.2.4 Complete unit

The complete unit shall be tested in accordance with BS EN 60947-4-1:1992 for performance, temperature rise, mechanical operation and endurance.

8.2.5 Additional type tests

Following completion of the mechanical endurance tests given in 7.8.1, the unit shall still conform to BS EN 60947-4-1:1992 and the operating limits given in 7.10.5.

A test shall prove satisfactory operation of the completely assembled unit with the cover(s) closed and when the base of the unit is tilted at an angle of 15° to the horizontal in the forward, backward and in each sideways direction.

8.2.6 Additional routine tests

In carrying out the following tests, precaution shall be taken to ensure that the test voltage is applied in such a manner as to avoid over-stressing the transformer insulation by induced over-voltage.

Dielectric strength tests shall be carried out on the unit with the cover(s) closed after being exposed to room atmosphere with the covers open for at least 24 h prior to test. The test voltage shall be obtained for an approximately sinusoidal a.c. source with a frequency between 40 Hz and 62 Hz.

The dielectric strength test shall be performed either by applying a test voltage of 1 000 V plus twice the working voltage of the circuit for 1 min, or by applying 1 250 V plus twice the working voltage of the circuit being tested for at least 3 s. In the case of dual-voltage units, using either test voltage, the higher rated voltage shall be taken as the working voltage.

NOTE 1 Instruments and other ancillary apparatus may be disconnected during this test and tested separately in accordance with an appropriate British Standard.

NOTE 2 A value of insulation resistance is not specified, as it is not practicable to prescribe limits for the range of apparatus covered by this standard. Further, it is considered that the high voltage test determines whether the insulation, is satisfactory or otherwise.

Tests shall be made as follows:

- a) with primary switch disconnecter open:
 - 1) between line phases of the incoming circuit;
 - 2) across each pole of the switch disconnecter connected directly or indirectly to the supply voltage;
- b) with all switch disconnectors and contactors closed:
 - 1) between line phases and other metal parts insulated therefrom, of incoming and outgoing circuits with the transformer(s) disconnected from earth;
 - 2) between incoming and outgoing circuits with the transformer fully connected;
 - 3) between the main poles and any independent circuits.

The unit shall be connected as it is intended to be installed, and shall be tested for correct functioning of the following, where fitted:

- i) short circuit protection (see 7.10.1);
- ii) undervoltage protection (see 7.10.5);
- iii) earth fault protection (see 7.10.2);
- iv) earth fault electrical lockout (see 7.10.3);
- v) pilot-to-earth fault protection and test facility (see 8.10.6);
- vi) provision for control (see 7.11).

9 Marking

9.1 Nameplates

All units shall be permanently marked with the following:

- a) the manufacturer's name or trademark;
- b) the serial number of the unit;
- c) the maximum rated output, in kilovolt-amperes;
- d) the rated supply voltage or voltage range, in volts or kilovolts;
- e) the output voltage or voltage range;
- f) the rated supply frequency;
- g) identification details of all interlocking, control, monitoring and auxiliary circuits which originate from within the unit and which are designed for use outside the unit, e.g. the intrinsically safe certification details, or reference standard relating to the construction of the circuit;

h) the rating of busbars;

i) the number of this British Standard, i.e. BS 5126-4:1993³⁾;

j) any additional marking required by the standards to be conformed to in 7.1.

9.2 Terminals

Any terminal identifications shall correspond to the diagrams required in 9.5.

The terminals to be marked and the information to be displayed shall be agreed between the supplier and the purchaser [see 4.2 f)].

9.3 Busbar interconnecting trunks

All busbar interconnecting trunks (see 7.4) shall be permanently marked with the following:

- a) the manufacturer's name or trade mark;
- b) the manufacturer's type or reference.

9.4 Busbar end covers

All busbar end covers (see 7.5) shall be permanently marked with the following:

- a) the manufacturer's name or trade mark;
- b) the manufacturer's type or reference.

9.5 Diagrams

Diagrams of connections shall be provided.

The form of the diagrams shall be agreed between the supplier and the purchaser [see 4.2 g)].

9.6 Warning notices

Any compartment containing live connections which can be isolated only elsewhere shall bear an external warning notice to that effect.

³⁾ Marking BS 5126-4:1993 on or in relation to a product represents a manufacturer's declaration of conformity, i.e. a claim by or on behalf of the manufacturer that the product meets the requirements of the standard. The accuracy of the claim is solely the claimant's responsibility. Such a declaration is not to be confused with third party certification of conformity, which may also be desirable.

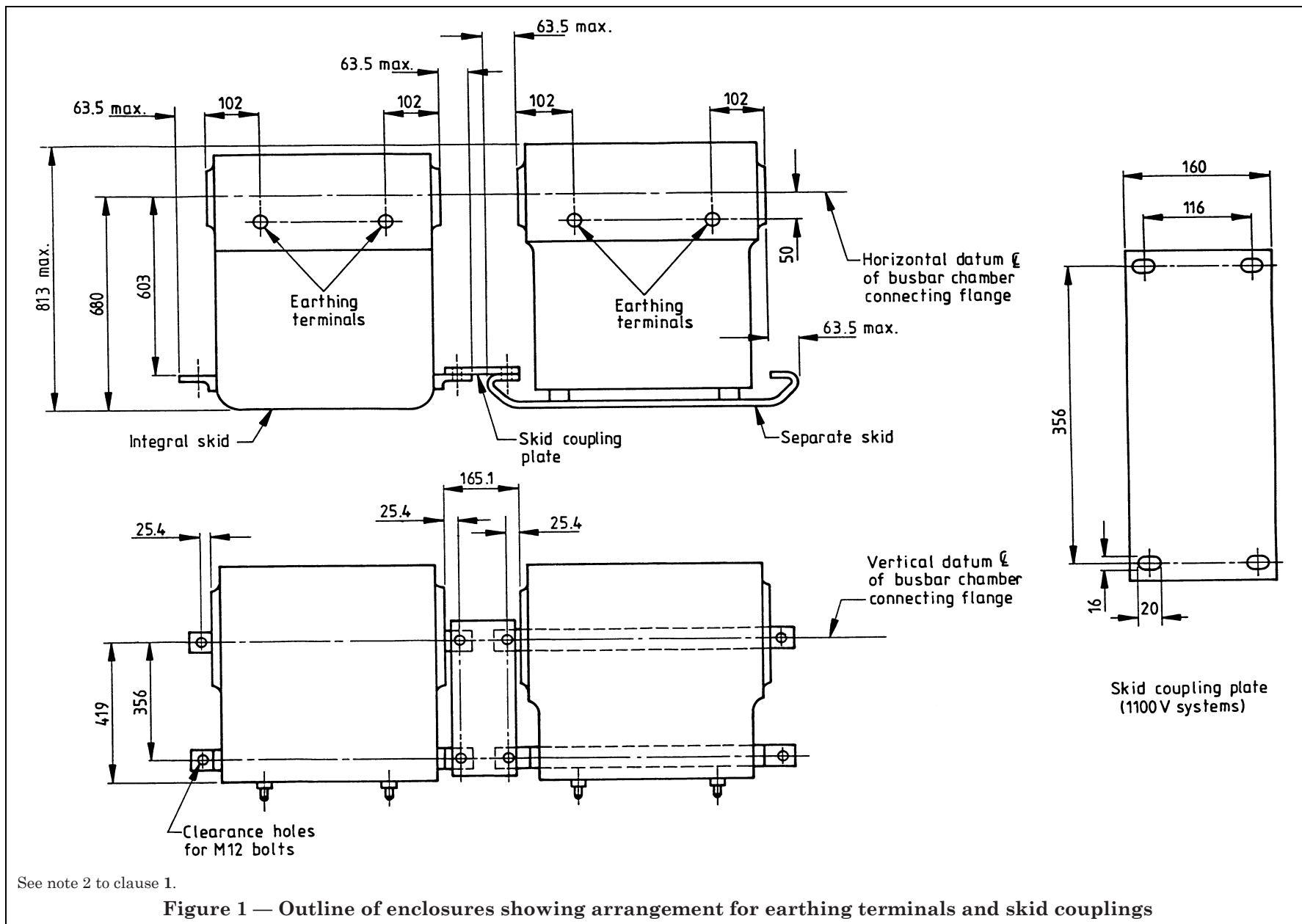

See note 2 to clause 1.

Figure 1 — Outline of enclosures showing arrangement for earthing terminals and skid couplings

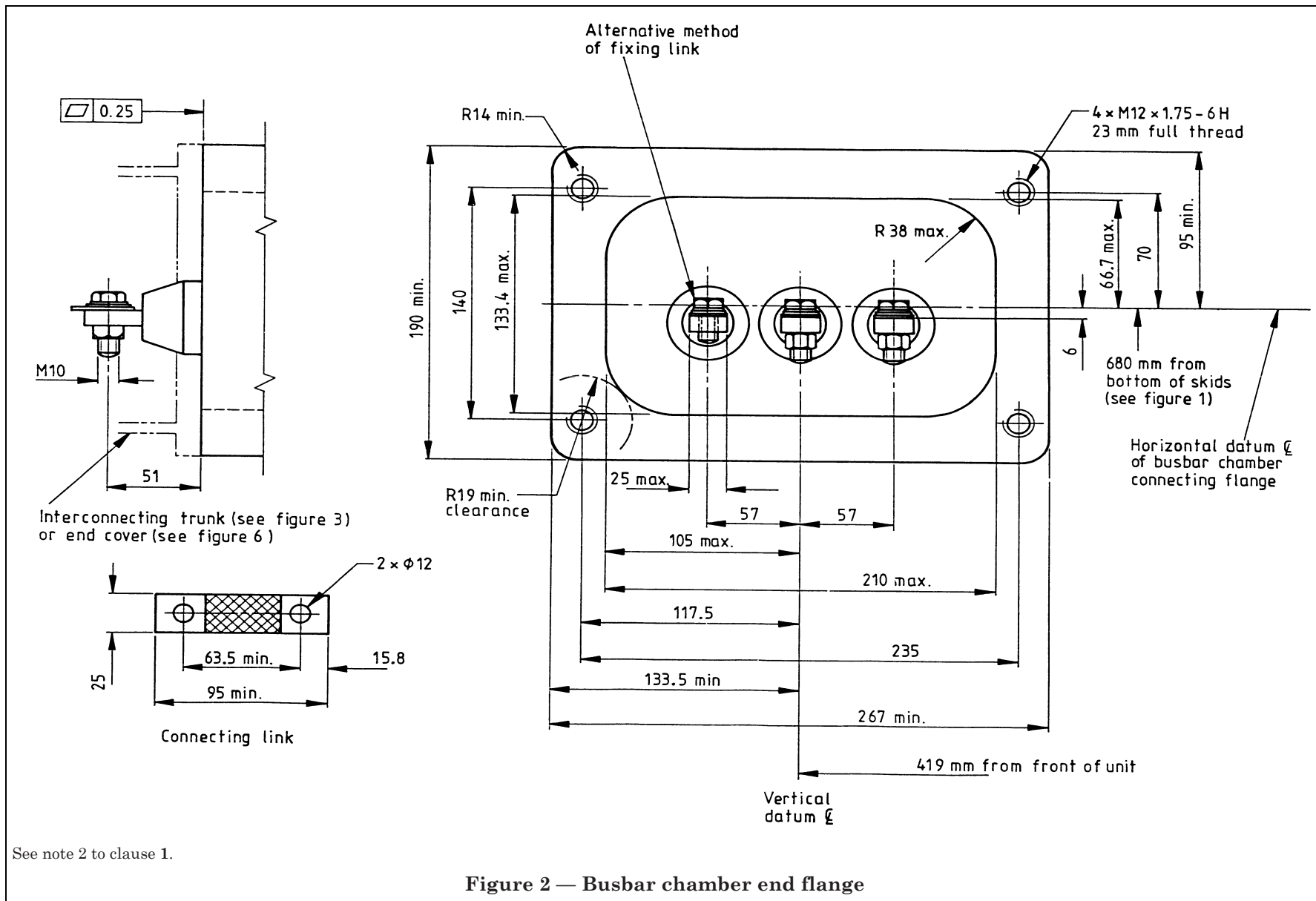

See note 2 to clause 1.

Figure 2 — Busbar chamber end flange

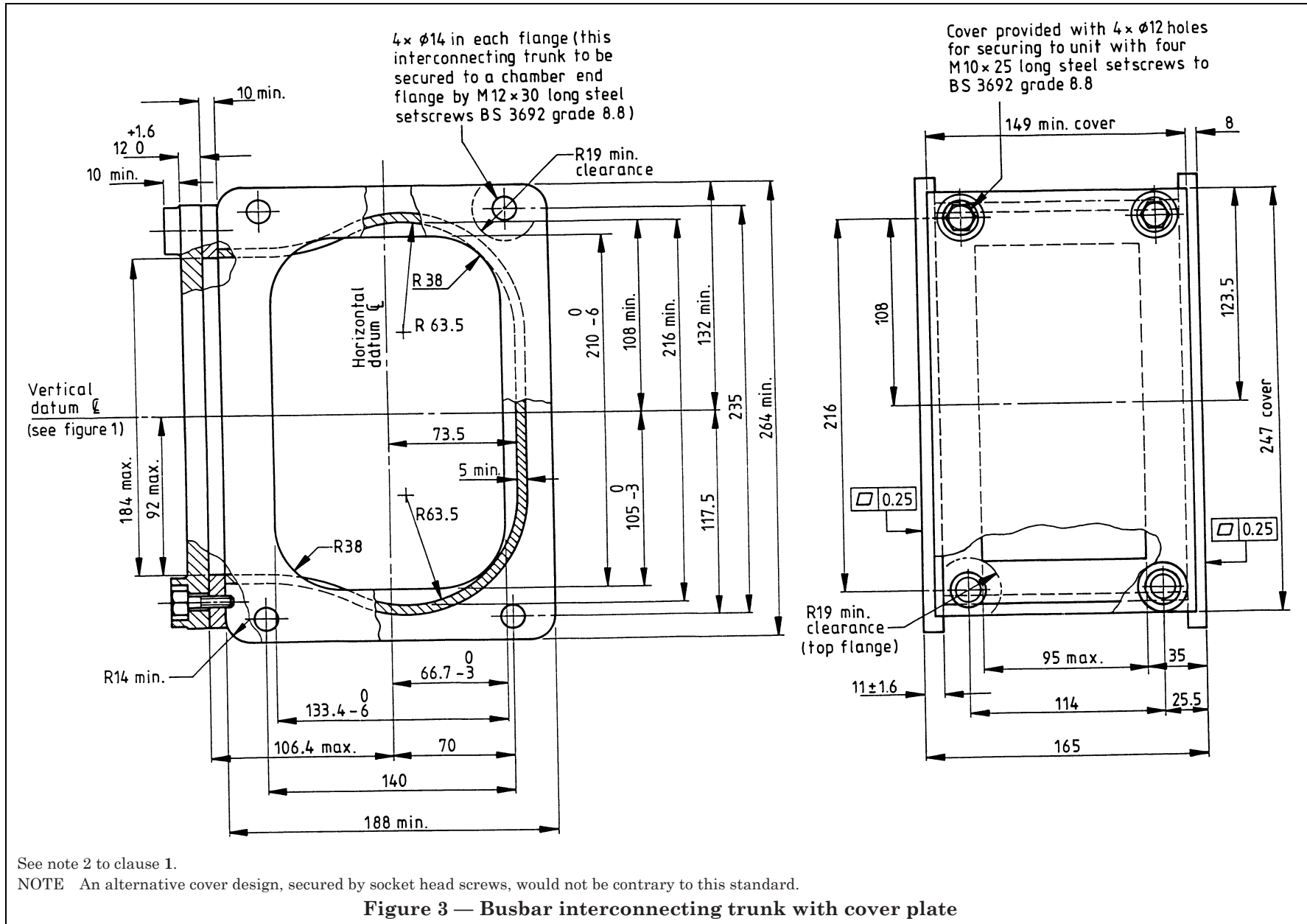
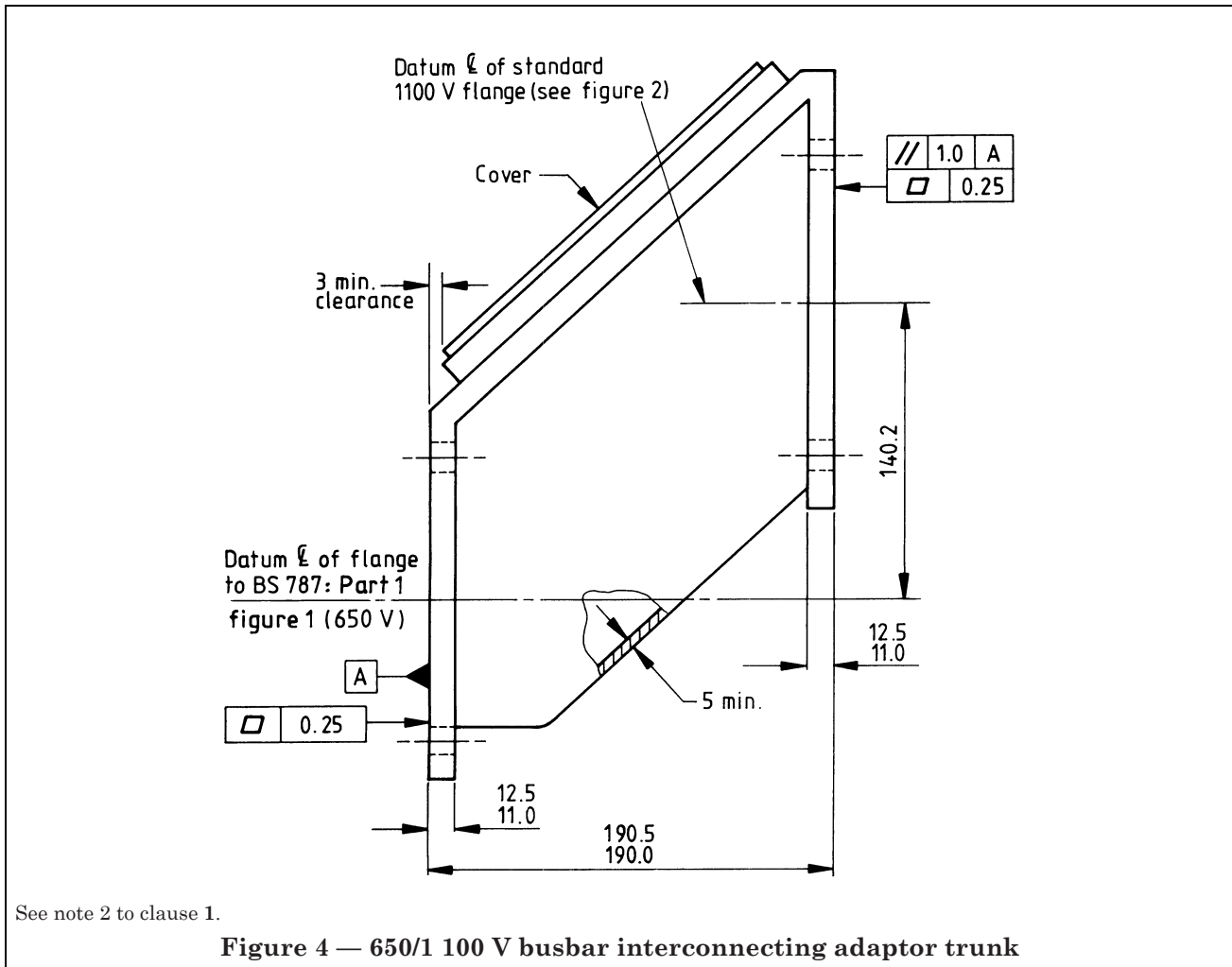
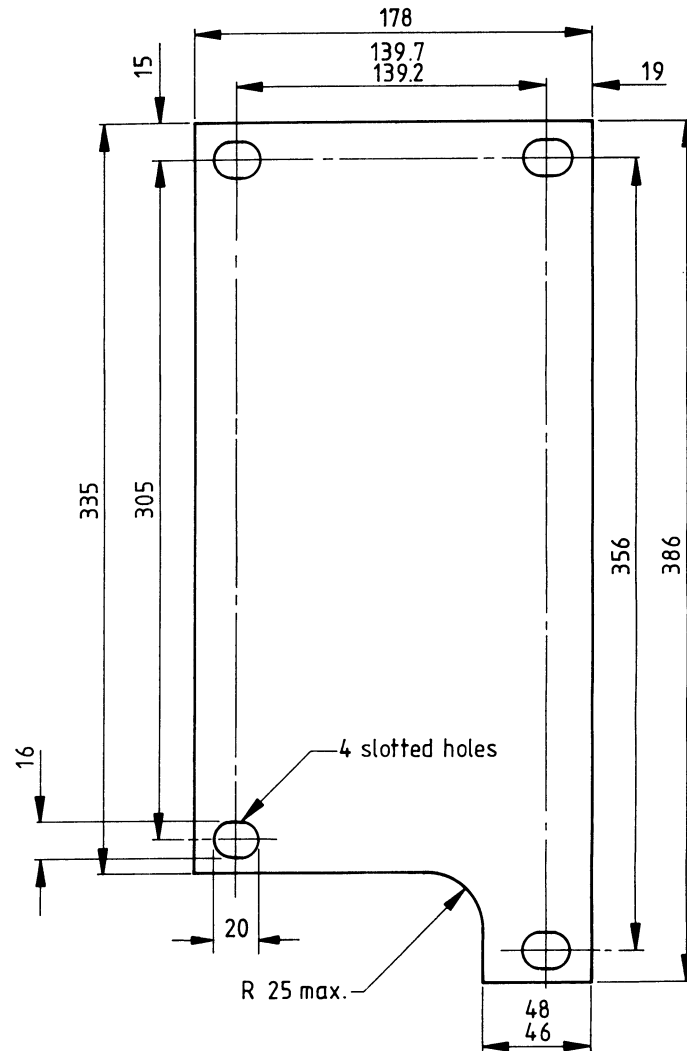

Figure 3 — Busbar interconnecting trunk with cover plate





See note 2 to clause 1.

Figure 5 — 650/1 100 V skid coupling plate

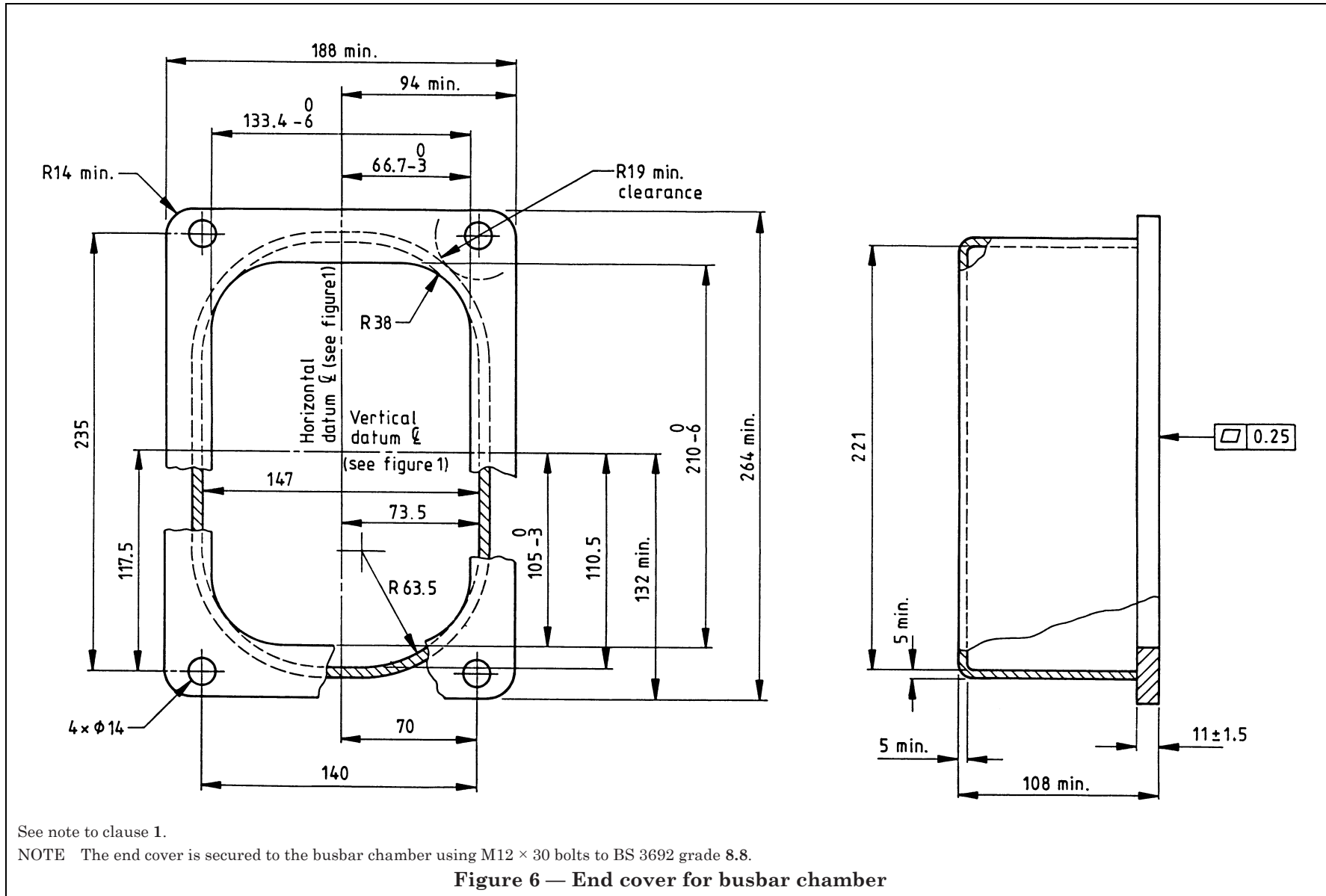

See note to clause 1.

NOTE The end cover is secured to the busbar chamber using M12 x 30 bolts to BS 3692 grade 8.8.

Figure 6 — End cover for busbar chamber

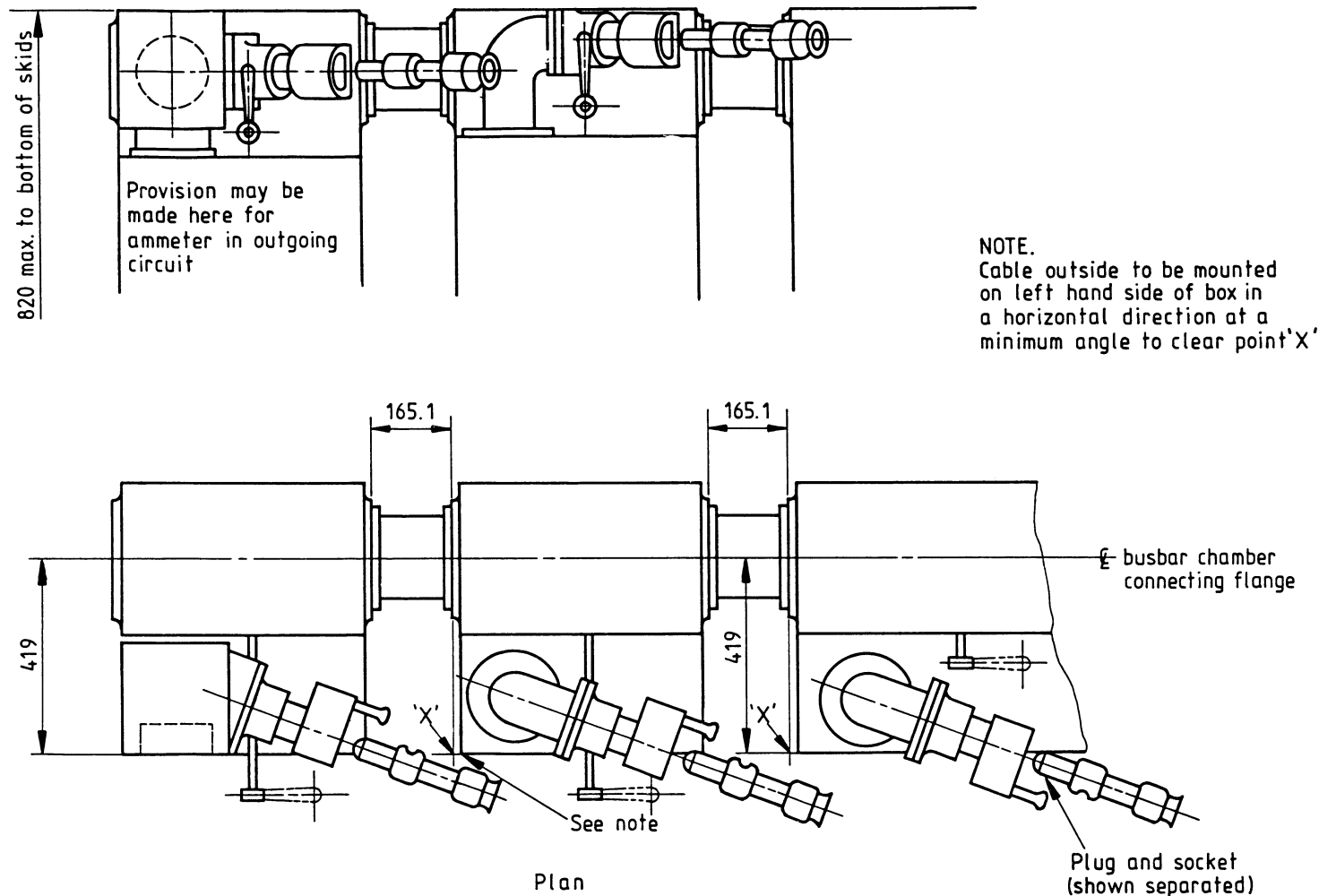

See note 2 to clause 1.

Figure 7 — Example of outgoing cable fittings

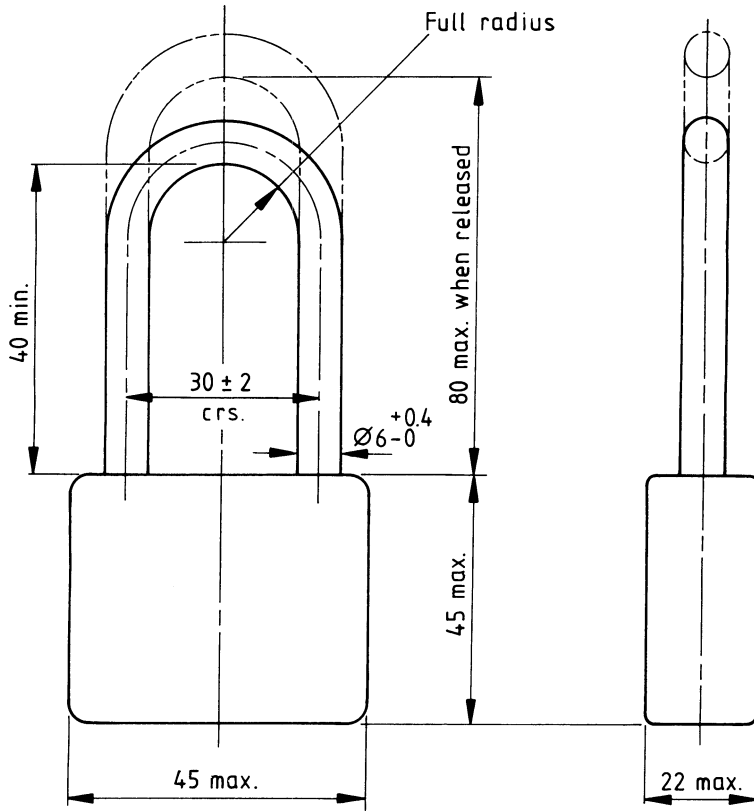

See note 2 to clause 1.

Figure 8 — Envelope dimensions for padlocks

List of references (see clause 2)

Normative references

BSI standards publications

BRITISH STANDARDS INSTITUTION, London

BS 88, *Cartridge fuses of voltages up to and including 1 000 V a.c. and 1 500 V d.c.*

BS 88-1:1988, *Specification of general requirements.*

BS 171, *Power transformers.*

BS 171-1:1978, *General.*

BS 171-2:1978, *Specification for temperature rise requirements.*

BS 787, *Specification for mining type flameproof gate-end boxes.*

BS 787-1:1969, *Gate-end boxes for direct-on-line motor starting (for use on 3-phase a.c. circuits up to 650 V).*

BS 1259:1958, *Intrinsically safe electrical apparatus and circuits for use in explosive atmospheres 1.*

BS 2692, *Fuses for voltages exceeding 1 000 V a.c.*

BS 2692-1:1986, *Specification for current-limiting fuses.*

BS 3101:1986, *Specification for control and interlock circuits primarily associated with flameproof restrained plugs and sockets for use in coal mines.*

BS 3692:1967, *Specification for ISO metric precision hexagon bolts, screws and nuts. Metric units.*

BS 4683, *Specification for electrical apparatus for explosive atmospheres.*

BS 4683-2:1971, *The construction and testing of flameproof enclosures of electrical apparatus.*

BS 5486, *Low-voltage switchgear and controlgear assemblies.*

BS 5486-2:1988, *Particular requirements for busbar trunking systems (busways).*

BS 5501, *Electrical apparatus for potentially explosive atmospheres.*

BS 5501-5:1977, *Flameproof enclosure 'd'.*

BS 5501-7:1977, *Intrinsic safety 'i'.*

BS 5901:1980, *Method of test for determining the comparative and the proof tracking indices of solid insulating materials under moist conditions.*

BS 6709:1986, *Specification for interconnection of electrical apparatus, constructed to two or more British Standards, for use in mines susceptible to firedamp.*

BS 7202:1989, *Specification for non-incendive low voltage control/interlock and low voltage earth fault monitoring circuits for use in mines.*

BS EN 60529:1992, *Specification for degrees of protection provided by enclosures.*

BS EN 60947, *Specification for low-voltage switchgear and controlgear.*

BS EN 60947-3:1992, *Switches, disconnectors, switch-disconnectors and fuse combination units.*

BS EN 60947-4, *Contactors and motor-starters.*

BS EN 60947-4-1:1992, *Electromechanical contactors and motor-starters.*

Informative references

BSI standards publications

BRITISH STANDARDS INSTITUTION, London

BS 229:1957, *Specification. Flameproof enclosure of electrical apparatus.*

BS 3454:1984, *Specification for 1.9/3.3 kV, 300 A bolted flameproof cable couplers and adaptors (including 380/660 V and 640/1 100 V, 300 A adaptors), primarily for use in mines.*

BS 5126, *Mining type flameproof supply and control units for use on systems up to 1 100 V.*

BS 5126-1:1993, *Specification for direct-on-line motor starters⁴⁾.*

BS 5126-2:1993, *Specification for circuit breaker units.*

BS 5126-3:1993, *Specification for air-cooled lighting transformer units.*

BS 6708:1991, *Specification for flexible cables for use at mines and quarries.*

BS 7383:1990, *Specification for cold-pour resin-based compound for use as a filling medium in terminating cables in enclosures for voltages not exceeding 11 kV for use in coal mines.*

Other references

[1] GREAT BRITAIN. Health and Safety at Work etc. Act 1974. London: HMSO⁴⁾.

[2] GREAT BRITAIN. Mines and Quarries Act 1954. London: HMSO⁴⁾.

⁴⁾ Referred to in the foreword only.

BSI — British Standards Institution

BSI is the independent national body responsible for preparing British Standards. It presents the UK view on standards in Europe and at the international level. It is incorporated by Royal Charter.

Revisions

British Standards are updated by amendment or revision. Users of British Standards should make sure that they possess the latest amendments or editions.

It is the constant aim of BSI to improve the quality of our products and services. We would be grateful if anyone finding an inaccuracy or ambiguity while using this British Standard would inform the Secretary of the technical committee responsible, the identity of which can be found on the inside front cover. Tel: 020 8996 9000. Fax: 020 8996 7400.

BSI offers members an individual updating service called PLUS which ensures that subscribers automatically receive the latest editions of standards.

Buying standards

Orders for all BSI, international and foreign standards publications should be addressed to Customer Services. Tel: 020 8996 9001. Fax: 020 8996 7001.

In response to orders for international standards, it is BSI policy to supply the BSI implementation of those that have been published as British Standards, unless otherwise requested.

Information on standards

BSI provides a wide range of information on national, European and international standards through its Library and its Technical Help to Exporters Service. Various BSI electronic information services are also available which give details on all its products and services. Contact the Information Centre. Tel: 020 8996 7111. Fax: 020 8996 7048.

Subscribing members of BSI are kept up to date with standards developments and receive substantial discounts on the purchase price of standards. For details of these and other benefits contact Membership Administration. Tel: 020 8996 7002. Fax: 020 8996 7001.

Copyright

Copyright subsists in all BSI publications. BSI also holds the copyright, in the UK, of the publications of the international standardization bodies. Except as permitted under the Copyright, Designs and Patents Act 1988 no extract may be reproduced, stored in a retrieval system or transmitted in any form or by any means – electronic, photocopying, recording or otherwise – without prior written permission from BSI.

This does not preclude the free use, in the course of implementing the standard, of necessary details such as symbols, and size, type or grade designations. If these details are to be used for any other purpose than implementation then the prior written permission of BSI must be obtained.

If permission is granted, the terms may include royalty payments or a licensing agreement. Details and advice can be obtained from the Copyright Manager. Tel: 020 8996 7070.