

CONFIRMED
JANUARY 1990

Specification for

**Spring washers for
general engineering
and automobile
purposes —
Metric series**

UDC 621.882.449

Co-operating organizations

The Mechanical Engineering Industry Standards Committee, under whose supervision this British Standard was prepared, consists of representatives from the following Government departments and scientific and industrial organizations:

Associated Offices' Technical Committee	Institute of Marine Engineers
Association of Consulting Engineers	Institution of Civil Engineers
Association of Mining Electrical and Mechanical Engineers	Institution of Gas Engineers
Board of Trade	Institution of Heating and Ventilating Engineers
British Chemical Plant Manufacturers' Association	Institution of Mechanical Engineers*
British Compressed Air Society	Institution of Mechanical Engineers (Automobile Division)
British Electrical and Allied Manufacturers' Association*	Institution of Production Engineers
British Gear Manufacturers' Association	Locomotive and Allied Manufacturers' Association of Great Britain
British Internal Combustion Engine Manufacturers' Association	London Transport Board
British Mechanical Engineering Confederation*	Machine Tool Trades Association
British Pump Manufacturers' Association	Ministry of Defence*
British Steel Industry	Ministry of Defence, Army Department
Crown Agents for Oversea Governments and Administrations	Ministry of Power
Department of Employment and Productivity (H.M. Factory Inspectorate)	Ministry of Public Building and Works
Electricity Council, the Central Electricity Generating Board and the Area Boards in England and Wales	Ministry of Technology*
Engineering Equipment Users' Association	Ministry of Technology — National Engineering Laboratory
Gas Council	Ministry of Transport
	National Coal Board
	National Physical Laboratory (Ministry of Technology)
	Royal Institute of British Architects

The Government departments and scientific and industrial organizations marked with an asterisk in the above list, together with the following, were directly represented on the committee entrusted with the preparation of this British Standard:

Institute of Iron and Steel Wire Manufacturers	Spring Research Association
Institution of Mechanical Engineers	Telecommunication Engineering and Manufacturing Association
Radio and Electronic Component Manufacturers Federation	
Society of Motor Manufacturers and Traders Ltd.	

This British Standard, having been approved by the Mechanical Engineering Industry Standards Committee, was published under the authority of the Executive Board on 19th May, 1969

© BSI 04-1999

The following BSI references relate to the work on this standard:
Committee reference MEE/134
Draft for comment 68/22810

Amendments issued since publication

Amd. No.	Date	Comments
4308	October 1983	Indicated by a sideline in the margin

Contents

	Page
Co-operating organizations	Inside front cover
Foreword	ii
<hr/>	
1 Scope	1
2 Material and mechanical properties	1
3 Finish	1
4 Coating	1
5 Shape	1
6 Ends	2
7 Tangling	2
8 Cranking	2
9 Dimensions	2
10 Functional tests	2
11 Quality control	3
12 Designation for enquiry, ordering and identification purposes	3
13 Identification marking	3
<hr/>	
Appendix A BSI policy statement on screw threads and the metric system	10
Appendix B Related British Standards	10
<hr/>	
Figure 1 — Twist test	2
<hr/>	
Table 1 — Single coil square section spring washers — Metric series (Type A)	4
Table 2 — Single coil rectangular section spring washers — Metric series (Types B and BP)	6
Table 3 — Double coil rectangular section spring washer — Metric series (Type D)	8
<hr/>	

Foreword

A complete list of British Standards, numbering over 9,000, fully indexed and with a note of the contents of each, will be found in the BSI Catalogue which may be purchased from BSI Sales Department. The Catalogue may be consulted in many public libraries and similar institutions.

This standard makes reference to the following British Standards:

BS 21, *Pipe threads.*

BS 427, *Method for Vickers hardness test.*

BS 860, *Tables for comparison of hardness scales.*

BS 970, *Wrought steels in the form of bars, billets and forgings up to 6 in, ruling section for automobile and general engineering purposes. En series.*

BS 1449, *Steel plate, sheet and strip.*

BS 1580, *Unified screw threads.*

BS 1706, *Electroplated coatings of cadmium and zinc on iron and steel.*

BS 1802, *Steel spring washers for general engineering and automobile purposes.*

BS 2061, *Phosphor bronze spring washers for general engineering purposes.*

BS 2870, *Rolled copper and copper alloys. Sheet, strip and foil.*

BS 2873, *Copper and copper alloys. Wire.*

BS 3643, *ISO metric screw threads.*

BS 9001, *Sampling procedures and tables for inspection by attributes for electronic parts of assessed quality.*

This British Standard Specification has been prepared under the authority of the Mechanical Engineering Industry Standards Committee as a result of the decision taken to adopt the ISO metric screw thread system in the United Kingdom (see Appendix A), and requests received from industry for the provision of a standard for metric series spring washers for general engineering and automobile purposes.

Although at present there are no ISO Recommendations or draft Recommendations relating specifically to spring washers, account has been taken of current documentation being considered by ISO Committee ISO/TC 2, "Bolts, nuts and accessories", and the following metric standards:

German Standard DIN 127, "Spring washers" (rectangular section).

German Standard DIN 7980, "Lock washers for fillister head cap screws" (square section).

Indian Standard IS: 3063, "Spring washers for bolts, nuts and screws".

A rationalized selection of ISO metric nominal sizes have been included in this specification, for use where appropriate with products manufactured to the metric threaded fastener standards listed in Appendix B. The tolerances adapted in this specification are similar to those utilized in the above-mentioned German Standards, with the exception of the limiting dimensions for the inside diameter (d_1). Concern has been expressed in British industry on the danger of spring washer failure due to "opening-out" under load, when the clearance between the inside diameter of the washer and the nominal thread size is too great.

Accordingly it was decided to reduce the limiting dimensions and tolerances for the inside diameter compared with those quoted in the specifications listed above.

Account has also been taken of the current British Standards (BS 1802¹) and BS 2061²), which deal with inch series products, and it was decided in this case to prepare a single specification covering mainly the dimensional and functional aspects of metric series spring washers, rather than a series of separate specifications differing only with regard to material requirements.

¹) BS 1802, "Steel spring washers for general engineering and automobile purposes".

²) BS 2061, "Phosphor bronze spring washers for general engineering purposes".

Spring washers are nowadays manufactured in a variety of materials and although recommendations with regard to the more commonly used spring steels and copper alloys have been included in this standard, the specification of the material requirements shall be the subject of agreement between the manufacturer and the purchaser.

Although spring washer “Type Designations” A, B and D, previously used in BS 1802³⁾ and BS 2061⁴⁾, have been included in this specification, the single coil girder section spring washer (Type C) has not been retained. A new “type designation” (Type BP) has been introduced, which has a single coil rectangular section, with deflected ends. This new type is extensively used on the continent, whereas there does not appear to be any metric standard covering girder section washers, or the double coil rectangular section (Type D). In the case of Type D, however, it was agreed to establish a metric series, due mainly to the usefulness of double coil washers as an anti-rattle device for applications involving light alloys.

A British Standard does not purport to include all the necessary provisions of a contract. Users of British Standards are responsible for their correct application.

Compliance with a British Standard does not of itself confer immunity from legal obligations.

Summary of pages

This document comprises a front cover, an inside front cover, pages i to iv, pages 1 to 10 and a back cover.

This standard has been updated (see copyright date) and may have had amendments incorporated. This will be indicated in the amendment table on the inside front cover.

³⁾ BS 1802, “Steel spring washers for general engineering and automobile purposes”.

⁴⁾ BS 2061, “Phosphor bronze spring washers for general engineering purposes”.

1 Scope

This British Standard specifies the dimensions, tolerances and general requirements for metric series spring washers of helical construction, suitable for use with metric threaded fasteners within the range 1.6 mm (M1.6) to 68 mm (M68) diameter. Dimensions and tolerances are specified for the following types:

<i>Type A.</i>	Single coil square section	Table 1
<i>Type B.</i>	Single coil rectangular section (with normal ends)	} Table 2
<i>Type BP.</i>	Single coil rectangular section (with deflected ends)	
<i>Type D.</i>	Double coil rectangular section	Table 3

NOTE Washers supplied in accordance with this specification are for use with right-hand threads, unless otherwise specified by the purchaser (see Clause 12).

2 Material and mechanical properties

2.1 The material to be used for the manufacture of spring washers to this specification shall be subject to agreement between the manufacturer and the purchaser and be in accordance with the appropriate British Standard specification for material.

2.1.1 Steel spring washers. For steel spring washers it is recommended that a material from the En 42 range be selected, as specified in BS 970⁵⁾, or BS 1449⁶⁾.

Hardened and tempered steel spring washers shall possess a hardness within the range HV 440 to 550 when tested in accordance with the provisions of BS 427⁷⁾.

NOTE Alternatively the equivalent hardness figures for other approved scales may be used, see BS 860, "Tables for comparison of hardness scales".

2.1.2 Phosphor bronze spring washers. For phosphor bronze spring washers it is recommended that materials PB 102 or PB 103 be selected, as specified in BS 2870⁸⁾ or BS 2873⁹⁾. PB 102 and PB 103 shall be in the hard tempered (H) condition and have mechanical properties in accordance with BS 2870⁸⁾ and BS 2873⁹⁾.

2.1.3 Copper silicon spring washers. For copper silicon spring washers it is recommended that material CS 101 be selected as specified in BS 2870⁸⁾ or BS 2873⁹⁾. The material CS 101 shall be in the hard tempered condition (H) and have a minimum tensile strength of 700 MN/m² (70 hbar).

2.1.4 Copper beryllium spring washers. For copper beryllium spring washers it is recommended that material CB 101 be selected as specified in BS 2870⁸⁾ or BS 2873⁹⁾. The material CB 101 shall be in the hard tempered [W (H)] condition and after heat treatment shall have the mechanical properties for the W (H)P condition as specified in BS 2870⁸⁾ and BS 2873⁹⁾.

3 Finish

Unless otherwise specified spring washers complying with this British Standard shall be of a natural "self-colour" finish and free from scale and burrs.

4 Coating

4.1 If the washers are required to have a protective or decorative finish, this shall be specified by the purchaser in his enquiry or order and reference shall be made to any appropriate British Standard.

NOTE The purchaser should give details of the thickness of plating required in accordance with the provisions of the appropriate British Standard, e.g. state BS classification number for cadmium or zinc plating to BS 1706¹⁰⁾.

4.2 The springiness of the washers shall not be impaired by any protective coating and where necessary any hydrogen embrittlement shall be removed (see BS 1706:1960¹⁰⁾, Appendix H).

5 Shape

The spring washers shall be evenly wound with uniform pitch and during use the washers shall remain circular and their section shall be such as not to cause them to spread when set down by a nut, under normal service conditions.

NOTE The dimensions given in Table 1, Table 2 and Table 3 are based on the use of standard square and rectangular wire sections. After coiling these produce washers of trapezoidal section with the inner periphery thicker than the outer, but with the limiting dimensions in accordance with the dimensions given in the appropriate tables.

⁵⁾ BS 970, "Wrought steels. En series".

⁶⁾ BS 1449, "Steel plate, sheet and strip".

⁷⁾ BS 427, "Method for Vickers hardness test".

⁸⁾ BS 2870, "Rolled copper and copper alloys. Sheet, strip and foil".

⁹⁾ BS 2873, "Copper and copper alloys. Wire".

¹⁰⁾ BS 1706, "Electroplated coatings of cadmium and zinc on iron and steel".

6 Ends

The ends of washers shall not abut when the washer is in the closed condition.

7 Tangling

Single coil washers having a sectional thickness greater than 1.6 mm shall be produced so that they shall not be liable to tangle or link together when in the free condition.

8 Cranking

Double coil washers shall be cranked so that the washer lies flat when closed under compression.

9 Dimensions

The dimensions of spring washers complying with this standard shall be in accordance with Table 1, Table 2 and Table 3 in the uncoated condition.

10 Functional tests

10.1 Spring washers complying with this standard shall show no cracks, imperfections or fractures after being subjected to the functional tests in **10.2**, **10.3** and **10.4**.

10.2 Closing and test for permanent set

10.2.1 *Single coil washers.* Sample washers shall be selected at random and completely closed. On release of the pressure the free height of each washer shall be as follows.

- 1) For steel spring washers and copper beryllium spring washers, not less than 1.66 times its sectional thickness.

- 2) For phosphor bronze spring washers and copper silicon spring washers, not less than 1.3 times its sectional thickness.

This application and removal of pressure shall then be repeated twenty times in quick succession, after which the free height shall not have been further reduced.

10.2.2 *Double coil washers.* Sample washers shall be selected at random and completely closed. On release of the pressure the free height of each washer shall be as follows.

- 1) For steel spring washers and copper beryllium spring washers, not less than three times its sectional thickness.
- 2) For phosphor bronze spring washers and copper silicon spring washers, not less than twice its sectional thickness.

This application and removal of pressure shall then be repeated twenty times in quick succession, after which the free height shall not have been further reduced.

10.3 *Twist test.* A portion of the washer shall be gripped in vice jaws and an equal portion shall be gripped in wrench jaws as shown in Figure 1. Edges of the wrench jaws shall be sharp and parallel to the vice jaws. The wrench shall then be slowly rotated in a direction that increases the free height of the spring washer till the washer is twisted through an angle of 90° . The washer shall show no signs of fracture. The vice and wrench jaws should be approximately $0.5 d_2$ apart.

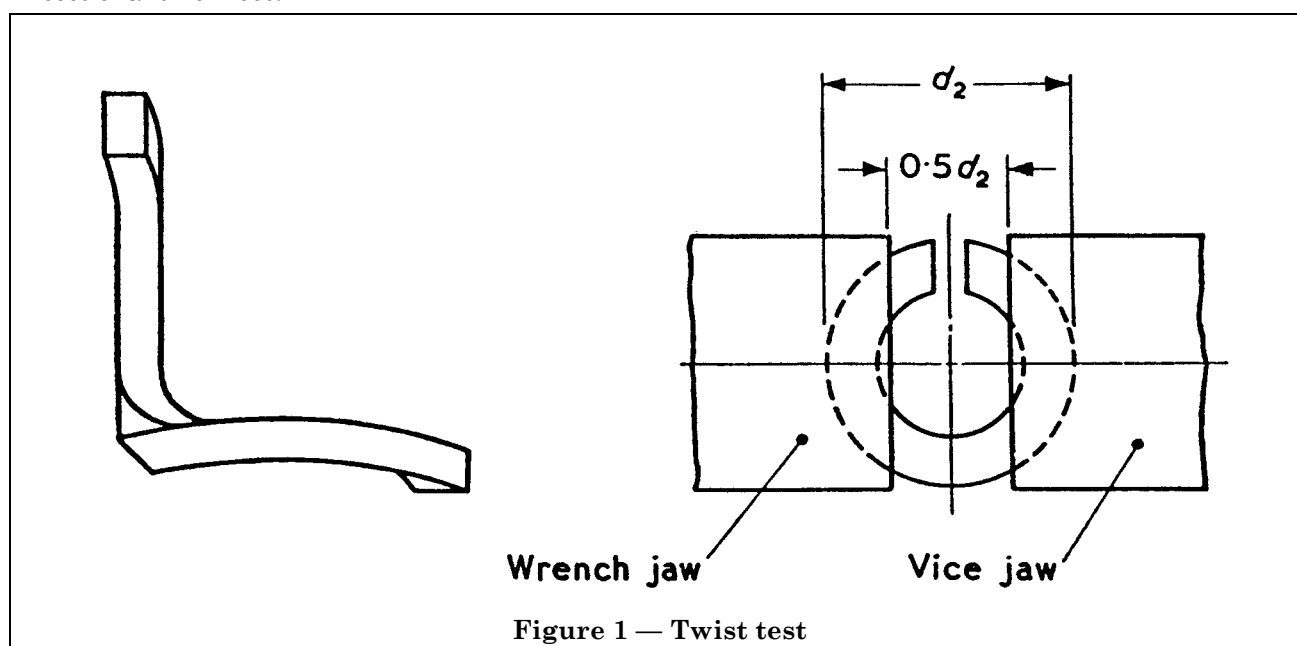

Figure 1 — Twist test

NOTE Precautions should be taken to prevent injuries from flying splinters.

10.4 Permanent load test. Ten spring washers shall be fully compressed for 24 hours. They shall show no signs of fracture.

11 Quality control

Acceptable quality levels (AQLs) applicable to products manufactured to this standard shall be subject to agreement between the manufacturer and purchaser, in accordance with BS 9001¹¹⁾.

12 Designation for enquiry, ordering and identification purposes

12.1 Information to be given. When designating spring washers for the purpose of an enquiry or order, the following information shall be given:

- 1) Material and appropriate British Standard material designation (where applicable)¹²⁾.
- 2) General product description, i.e. "Spring washers".
- 3) Nominal size (thread diameter), e.g. "M5" (see Table 1, Table 2 and Table 3).
- 4) Type designation, Type A, B, BP or D.
- 5) The number of this British Standard, i.e. BS 4464.
- 6) Details of coating (if required), in accordance with the appropriate British Standard, giving thickness classification where applicable (see Clause 4).

12.2 Examples

1) Single coil rectangular section steel spring washers (normal ends) cadmium plated, to suit 10 mm diameter bolts or screws, could be designated:

"Steel (En42F) spring washers M10 (Type B) to BS 4464, cadmium plated to Cd2, BS 1706¹³⁾".

2) Single coil square section phosphor bronze spring washers to suit 3 mm diameter bolts or screws, could be designated:

Phosphor bronze (PB 103) spring washers M3 (Type A) to BS 4464".

NOTE In the case of spring washers intended for use with left hand threads, this also should be clearly stated in the enquiry or order.

13 Identification marking

Packages containing spring washers shall be identified by labelling marked with the designation, in accordance with Clause 12, the manufacturer's name (or trade mark) and the quantity of washers.

¹¹⁾ BS 9001, "Sampling procedures and tables for inspection by attributes for electronic parts of assessed quality".

¹²⁾ For information relating to British Standard material designations see BS 1449, "Steel plate sheet and strip", BS 2870, "Rolled copper and copper alloys. Sheet strip and foil", and BS 2873, "Copper and copper alloys. Wire".

¹³⁾ BS 1706, "Electroplated coatings of cadmium and zinc on iron and steel".

Table 1 — Single coil square section spring washers — Metric series (Type A)

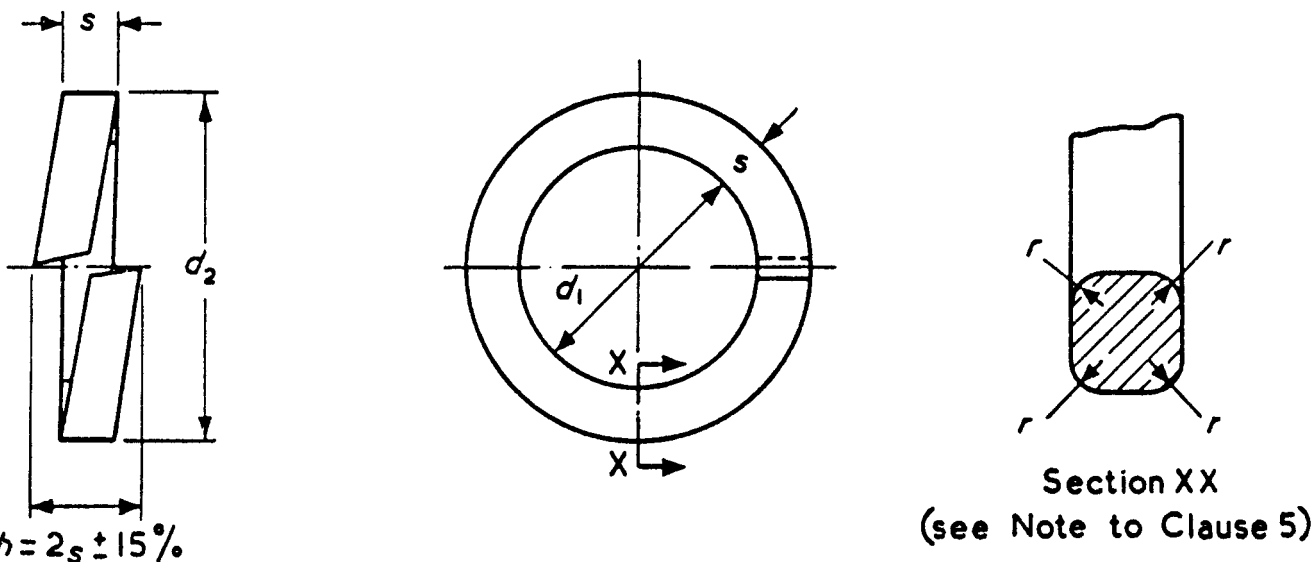

All dimensions in millimetres

1	2	3	4	5	6
Nominal size and thread diameter <i>d</i>	Inside diameter <i>d</i> ₁		Thickness and width <i>s</i>	Outside diameter <i>d</i> ₂ max.	Radius <i>r</i> max.
	max.	min.			
M3	3.3	3.1	1 ± 0.1	5.5	0.3
(M3.5)	3.8	3.6	1 ± 0.1	6.0	0.3
M4	4.35	4.1	1.2 ± 0.1	6.95	0.4
M5	5.35	5.1	1.5 ± 0.1	8.55	0.5
M6	6.4	6.1	1.5 ± 0.1	9.6	0.5
M8	8.55	8.2	2 ± 0.1	12.75	0.65
M10	10.6	10.2	2.5 ± 0.15	15.9	0.8
M12	12.6	12.2	2.5 ± 0.15	17.9	0.8
(M14)	14.7	14.2	3 ± 0.2	21.1	1.0
M16	16.9	16.3	3.5 ± 0.2	24.3	1.15
(M18)	19.0	18.3	3.5 ± 0.2	26.4	1.15
M20	21.1	20.3	4.5 ± 0.2	30.5	1.5

Table 1 — Single coil square section spring washers — Metric series (Type A)

1	2	3	4	5	6
Nominal size and thread diameter <i>d</i>	Inside diameter <i>d</i> ₁		Thickness and width <i>s</i>	Outside diameter <i>d</i> ₂ max.	Radius <i>r</i> max.
	max.	min.			
(M22)	23.3	22.4	4.5 ± 0.2	32.7	1.5
M24	25.3	24.4	5 ± 0.2	35.7	1.65
(M27)	28.5	27.5	5 ± 0.2	38.9	1.65
M30	31.5	30.5	6 ± 0.2	43.9	2.0
(M33)	34.6	33.5	6 ± 0.2	47.0	2.0
M36	37.6	36.5	7 ± 0.25	52.1	2.3
(M39)	40.8	39.6	7 ± 0.25	55.3	2.3
M42	43.8	42.6	8 ± 0.25	60.3	2.65
(M45)	46.8	45.6	8 ± 0.25	63.3	2.65
M48	50.0	48.8	8 ± 0.25	66.5	2.65

NOTE Sizes shown in brackets are non-preferred and are not usually stock sizes.

Table 2 — Single coil rectangular section spring washers — Metric series (Types B and BP)

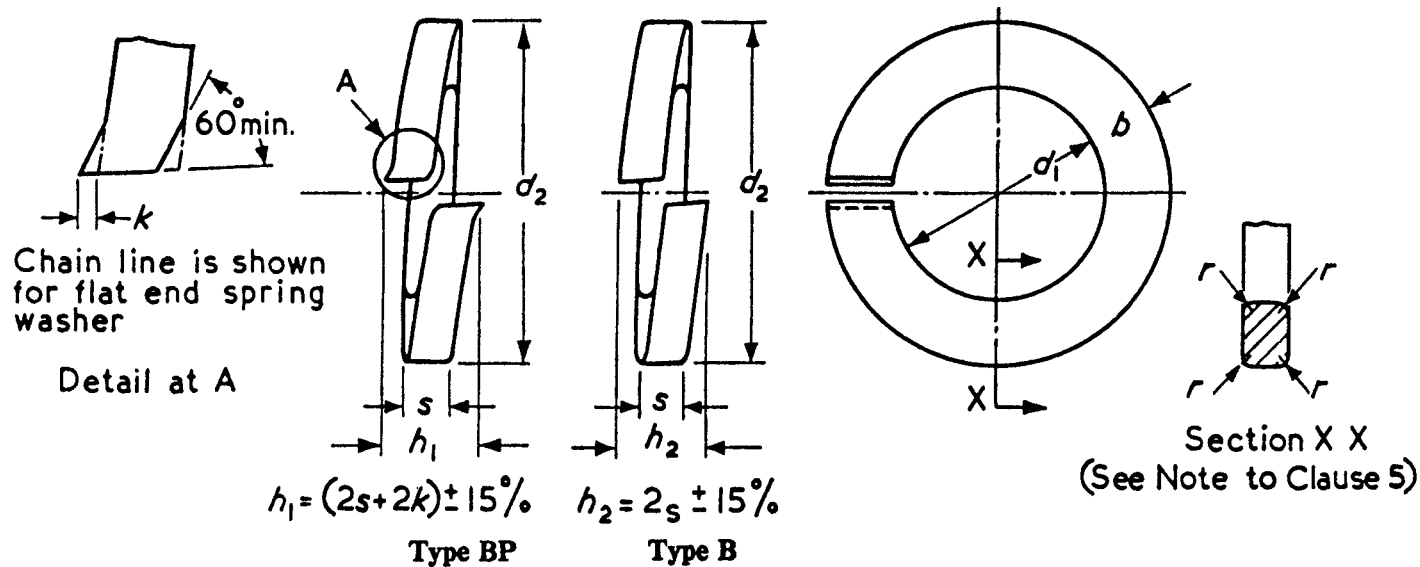

All dimensions in millimetres

1	2	3	4	5	6	7	8
Nominal size and thread diameter <i>d</i>	Inside diameter <i>d</i> ₁		Width <i>b</i>	Thickness <i>s</i>	Outside diameter <i>d</i> ₂ max.	Radius <i>r</i> max.	<i>k</i> (Type BP only)
	max.	min.					
M1.6	1.9	1.7	0.7 ± 0.1	0.4 ± 0.1	3.5	0.15	—
M2	2.3	2.1	0.9 ± 0.1	0.5 ± 0.1	4.3	0.15	—
(M2.2)	2.5	2.3	1.0 ± 0.1	0.6 ± 0.1	4.7	0.2	—
M2.5	2.8	2.6	1.0 ± 0.1	0.6 ± 0.1	5.0	0.2	—
M3	3.3	3.1	1.3 ± 0.1	0.8 ± 0.1	6.1	0.25	—
(M3.5)	3.8	3.6	1.3 ± 0.1	0.8 ± 0.1	6.6	0.25	0.15
M4	4.35	4.1	1.5 ± 0.1	0.9 ± 0.1	7.55	0.3	0.15
M5	5.35	5.1	1.8 ± 0.1	1.2 ± 0.1	9.15	0.4	0.15
M6	6.4	6.1	2.5 ± 0.15	1.6 ± 0.1	11.7	0.5	0.2
M8	8.55	8.2	3 ± 0.15	2 ± 0.1	14.85	0.65	0.3
M10	10.6	10.2	3.5 ± 0.2	2.2 ± 0.15	18.0	0.7	0.3
M12	12.6	12.2	4 ± 0.2	2.5 ± 0.15	21.0	0.8	0.4

Table 2 — Single coil rectangular section spring washers — Metric series (Types B and BP)

1	2	3	4	5	6	7	8
Nominal size and thread diameter <i>d</i>	Inside diameter <i>d</i> ₁		Width <i>b</i>	Thickness <i>s</i>	Outside diameter <i>d</i> ₂ max.	Radius <i>r</i> max.	<i>k</i> (Type BP only)
	max.	min.					
(M14)	14.7	14.2	4.5 ± 0.2	3 ± 0.15	24.1	1.0	0.4
M16	16.9	16.3	5 ± 0.2	3.5 ± 0.2	27.3	1.15	0.4
(M18)	19.0	18.3	5 ± 0.2	3.5 ± 0.2	29.4	1.15	0.4
M20	21.1	20.3	6 ± 0.2	4 ± 0.2	33.5	1.3	0.4
(M22)	23.3	22.4	6 ± 0.2	4 ± 0.2	35.7	1.3	0.4
M24	25.3	24.4	7 ± 0.25	5 ± 0.2	39.8	1.65	0.5
(M27)	28.5	27.5	7 ± 0.25	5 ± 0.2	43.0	1.65	0.5
M30	31.5	30.5	8 ± 0.25	6 ± 0.25	48.0	2.0	0.8
(M33)	34.6	33.5	10 ± 0.25	6 ± 0.25	55.1	2.0	0.8
M36	37.6	36.5	10 ± 0.25	6 ± 0.25	58.1	2.0	0.8
(M39)	40.8	39.6	10 ± 0.25	6 ± 0.25	61.3	2.0	0.8
M42	43.8	42.6	12 ± 0.25	7 ± 0.25	68.3	2.3	0.8
(M45)	46.8	45.6	12 ± 0.25	7 ± 0.25	71.3	2.3	0.8
M48	50.0	48.8	12 ± 0.25	7 ± 0.25	74.5	2.3	0.8
(M52)	54.1	52.8	14 ± 0.25	8 ± 0.25	82.6	2.65	1.0
M56	58.1	56.8	14 ± 0.25	8 ± 0.25	86.6	2.65	1.0
(M60)	62.3	60.9	14 ± 0.25	8 ± 0.25	90.8	2.65	1.0
M64	66.3	64.9	14 ± 0.25	8 ± 0.25	93.8	2.65	1.0
(M68)	70.5	69.0	14 ± 0.25	8 ± 0.25	99.0	2.65	1.0

NOTE Sizes shown in brackets are non-preferred, and are not usually stock sizes.

Table 3 — Double coil rectangular section spring washer — Metric series (Type D)

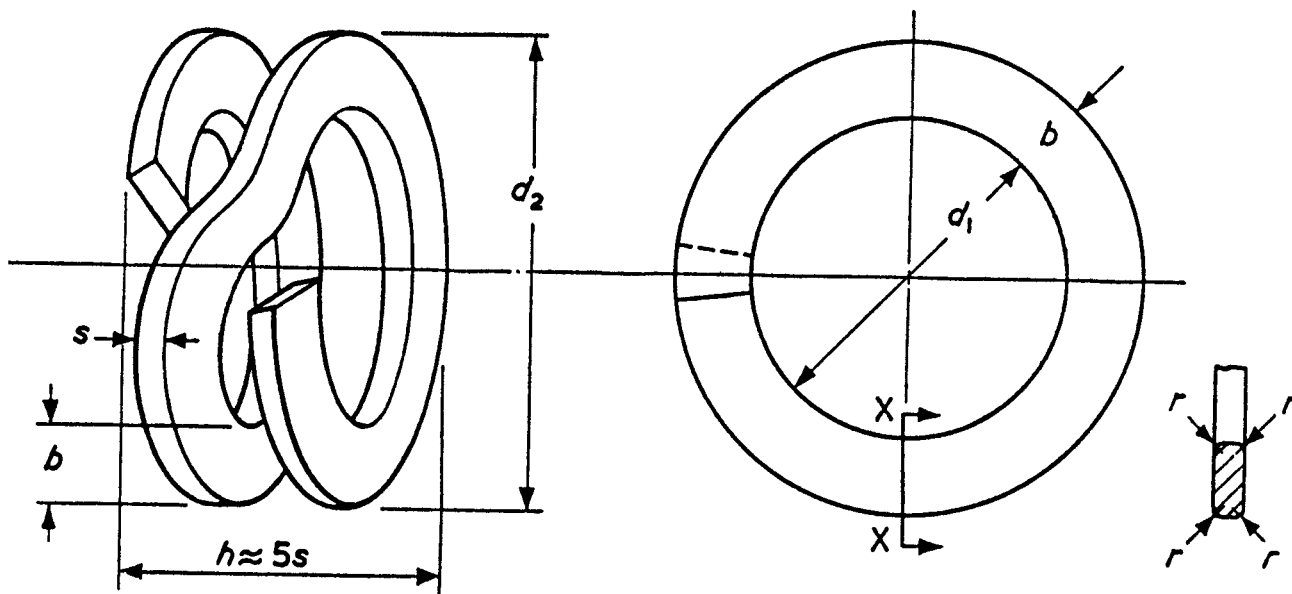

SECTION XX
(see Note to Clause 5)

All dimensions in millimetres

1	2	3	4	5	6	7
Nominal size and thread diameter <i>d</i>	Inside diameter <i>d</i> ₁		Width <i>b</i>	Thickness <i>s</i>	Outside diameter <i>d</i> ₂ max.	Radius <i>r</i> max.
	max.	min.				
M2	2.4	2.1	0.9 ± 0.1	0.5 ± 0.05	4.4	0.15
(M2.2)	2.6	2.3	1.0 ± 0.1	0.6 ± 0.05	4.8	0.2
M2.5	2.9	2.6	1.2 ± 0.1	0.7 ± 0.1	5.5	0.23
M3.0	3.6	3.3	1.2 ± 0.1	0.8 ± 0.1	6.2	0.25
(M3.5)	4.1	3.8	1.6 ± 0.1	0.8 ± 0.1	7.5	0.25
M4	4.6	4.3	1.6 ± 0.1	0.8 ± 0.1	8.0	0.25
M5	5.6	5.3	2 ± 0.1	0.9 ± 0.1	9.8	0.3
M6	6.6	6.3	3 ± 0.15	1 ± 0.1	12.9	0.33
M8	8.8	8.4	3 ± 0.15	1.2 ± 0.1	15.1	0.4

Table 3 — Double coil rectangular section spring washer — Metric series (Type D)

1	2	3	4	5	6	7
Nominal size and thread diameter <i>d</i>	Inside diameter <i>d</i> ₁		Width <i>b</i>	Thickness <i>s</i>	Outside diameter <i>d</i> ₂ max.	Radius <i>r</i> max.
	max.	min.				
M10	10.8	10.4	3.5 ± 0.20	1.2 ± 0.1	18.2	0.4
M12	12.8	12.4	3.5 ± 0.2	1.6 ± 0.1	20.2	0.5
(M14)	15.0	14.5	5 ± 0.2	1.6 ± 0.1	25.4	0.5
M16	17.0	16.5	5 ± 0.2	2 ± 0.1	27.4	0.65
(M18)	19.0	18.5	5 ± 0.2	2 ± 0.1	29.4	0.65
M20	21.5	20.8	5 ± 0.2	2 ± 0.1	31.9	0.65
(M22)	23.5	22.8	6 ± 0.2	2.5 ± 0.15	35.9	0.8
M24	26.0	25.0	6.5 ± 0.2	3.25 ± 0.15	39.4	1.1
(M27)	29.5	28.0	7 ± 0.25	3.25 ± 0.15	44.0	1.1
M30	33.0	31.5	8 ± 0.25	3.25 ± 0.15	49.5	1.1
(M33)	36.0	34.5	8 ± 0.25	3.25 ± 0.15	52.5	1.1
M36	40.0	38.0	10 ± 0.25	3.25 ± 0.15	60.5	1.1
(M39)	43.0	41.0	10 ± 0.25	3.25 ± 0.15	63.5	1.1
M42	46.0	44.0	10 ± 0.25	4.5 ± 0.2	66.5	1.5
M48	52.0	50.0	10 ± 0.25	4.5 ± 0.2	72.5	1.5
M56	60.0	58.0	12 ± 0.25	4.5 ± 0.2	84.5	1.5
M64	70.0	67.0	12 ± 0.25	4.5 ± 0.2	94.5	1.5

NOTE 1 Sizes shown in brackets are non-preferred, and are not usually stock sizes.

NOTE 2 The free height of double coil washers before compression is normally approximately five times the thickness but, if required, washers with other free heights may be obtained by arrangement between the purchaser and the manufacturer.

Appendix A BSI policy statement on screw threads and the metric system

The major sectors of British industry were represented at a conference organized by the BSI on 23rd November, 1965. They gave their approval to a policy statement which urged British firms to regard the traditional screw thread systems — Whitworth, BA and BSF — as obsolescent, and to make the internationally agreed ISO metric thread their first choice (with the ISO Unified thread as second choice) for all future designs.

Prior to the conference the statement had been endorsed by the Mechanical Engineering Industry Standards Committee, the Engineering Divisional Council and the General Council of BSI.

The following is the text of the policy statement:

On 24th May, 1965, the Right Hon. Douglas Jay, the President of the Board of Trade, announced in Parliament that it would be desirable for this country to change to the metric system. An extract from his statement is given below:

“... British industries on a broadening front should adopt metric units sector by sector, until that system can become in time the primary system of weights and measures for the country as a whole ... the Government hope that within ten years the greater part of the country's industry will have effected the change. ...”

The national need for increased exports coupled with maximum efficiency and economy of production lies behind the above statement and makes it essential to give urgent and serious consideration to the screw thread situation in the United Kingdom.

After many years' work the International Organization for Standardization (ISO) has reached agreement on ISO Recommendations for general purpose screw threads. This agreement will enable the industries of the world to align the usage of screw threads and to minimize the present diversities of practice.

The ISO Recommendations comprise a system of ISO metric threads¹⁴⁾ and a system of ISO inch threads¹⁵⁾. The ISO inch threads are the same as the existing Unified threads.

In view of the world trend towards the metric system, and having particular regard to the declared UK National Policy for its adoption, it is strongly recommended that British Industry should adopt the ISO metric screw thread system.

Although it is appreciated that some of those sections of industry already using ISO inch (Unified) screw threads may find it necessary, for various reasons, to continue with their use for some time, Whitworth and BA threads should be superseded by ISO metric threads in preference to an intermediate change to ISO inch threads.

NOTE Threads on pipes will continue to be BSP (BS 21, “Pipe threads”) which have been adopted as the ISO pipe thread and which are covered in ISO Recommendation R7, “Pipe threads for gas lit tubes and screwed fittings where pressure-tight joints are made on the threads ($\frac{1}{8}$ in to 6 in)”.

Appendix B Related British Standards

BS 856, *Wing nuts*.

BS 3643, *ISO metric screw threads*.

BS 3643-1, *Thread data and standard thread series*.

BS 3643-2, *Limits and tolerances for coarse pitch series threads*.

BS 3643-3, *Limits and tolerances for fine pitch threads (constant pitch series)*.

BS 3692, *ISO metric precision hexagon bolts, screws and nuts*.

BS 4168, *Hexagon socket screws and wrench keys — metric series*.

BS 4183, *Machine screws and machine screw nuts — metric series*.

BS 4185, *Machine tool components*.

BS 4185-1, *Locknuts (“C” type, socket set screw locking)*.

BS 4185-2, *Collars*.

BS 4186, *Recommendations for clearance holes for metric bolts and screws*.

BS 4190, *ISO metric black hexagon bolts, screws and nuts*.

BS 4219, *Slotted grub screws — metric series*.

BS 4320, *Metal washers for general engineering purposes*.

BS 4377, *The tapping of holes to receive wire thread inserts (ISO metric threads)*.

BS 4439, *Screwed studs for general purposes — metric series*.

BS 4463, *Crinkle washers for general engineering purposes — metric series*.

Supplement No. 1 to BS 1157. Tapping drill sizes for ISO metric screw threads in accordance with BS 3643.

¹⁴⁾ BS 3643, “ISO metric screw threads”.

¹⁵⁾ BS 1580, “Unified screw threads”.

BSI — British Standards Institution

BSI is the independent national body responsible for preparing British Standards. It presents the UK view on standards in Europe and at the international level. It is incorporated by Royal Charter.

Revisions

British Standards are updated by amendment or revision. Users of British Standards should make sure that they possess the latest amendments or editions.

It is the constant aim of BSI to improve the quality of our products and services. We would be grateful if anyone finding an inaccuracy or ambiguity while using this British Standard would inform the Secretary of the technical committee responsible, the identity of which can be found on the inside front cover. Tel: 020 8996 9000. Fax: 020 8996 7400.

BSI offers members an individual updating service called PLUS which ensures that subscribers automatically receive the latest editions of standards.

Buying standards

Orders for all BSI, international and foreign standards publications should be addressed to Customer Services. Tel: 020 8996 9001. Fax: 020 8996 7001.

In response to orders for international standards, it is BSI policy to supply the BSI implementation of those that have been published as British Standards, unless otherwise requested.

Information on standards

BSI provides a wide range of information on national, European and international standards through its Library and its Technical Help to Exporters Service. Various BSI electronic information services are also available which give details on all its products and services. Contact the Information Centre. Tel: 020 8996 7111. Fax: 020 8996 7048.

Subscribing members of BSI are kept up to date with standards developments and receive substantial discounts on the purchase price of standards. For details of these and other benefits contact Membership Administration. Tel: 020 8996 7002. Fax: 020 8996 7001.

Copyright

Copyright subsists in all BSI publications. BSI also holds the copyright, in the UK, of the publications of the international standardization bodies. Except as permitted under the Copyright, Designs and Patents Act 1988 no extract may be reproduced, stored in a retrieval system or transmitted in any form or by any means – electronic, photocopying, recording or otherwise – without prior written permission from BSI.

This does not preclude the free use, in the course of implementing the standard, of necessary details such as symbols, and size, type or grade designations. If these details are to be used for any other purpose than implementation then the prior written permission of BSI must be obtained.

If permission is granted, the terms may include royalty payments or a licensing agreement. Details and advice can be obtained from the Copyright Manager. Tel: 020 8996 7070.