

Specification for
Industrial nitrogen

UDC 661.938

Confirmed
December 2011

Committees responsible for this British Standard

The preparation of this British Standard was entrusted by the Chemicals Standards Policy Committee (CIC/-) to Technical Committee CIC/19, upon which the following bodies were represented:

Brewers Society
British Compressed Gases Association
British Soft Drinks Association Ltd.
Ministry of Defence

This British Standard, having been prepared under the direction of the Chemicals Standards Policy Committee, was published under the authority of the Standards Board and comes into effect on 15 February 1993

© BSI 04-1999

First published November 1968
Withdrawn 1988
Second edition February 1993

The following BSI references relate to the work on this standard:
Committee reference CIC/19
Draft for comment 92/81607 DC

ISBN 0 580 21537 7

Amendments issued since publication

Amd. No.	Date	Comments

Contents

	Page
Committees responsible	Inside front cover
Foreword	ii
<hr/>	
1 Scope	1
2 References	1
3 Description	1
4 Sampling	1
5 Oxygen content	1
6 Carbon monoxide and carbon dioxide content	1
7 Total hydrocarbons content	1
8 Water content	1
9 Nitrogen content	1
10 Containers	1
11 Labelling	1
<hr/>	
Annex A (informative) Safety considerations for the handling of nitrogen	2
Annex B (normative) Method for the determination of oxygen content	2
Annex C (normative) Method for the determination of carbon monoxide and carbon dioxide content	4
Annex D (normative) Method for the determination of total hydrocarbons content	4
Annex E (normative) Method for the determination of water content	4
<hr/>	
Figure B.1 — Configuration of unit for electrochemical determination of oxygen using aqueous electrolyte	3
Figure B.2 — Configuration of unit for electrochemical determination of oxygen using gel electrolyte	3
Figure D.1 — Flame ionization detector (schematic)	4
List of references	Inside back cover
<hr/>	

Foreword

This British Standard has been prepared under the direction of the Chemicals Standards Policy Committee. BS 4366:1968 was withdrawn in 1988 as obsolete. At about the same time an EC draft Directive on Food Additives (including gases) was issued, requiring standards of purity of additives to be established in the implementing legislation. This, together with representation from numerous concerns, in particular the welding industry, indicated a need for a revised British Standard to be prepared.

This standard represents a complete revision of BS 4366:1968, in order to provide a practical standard for both producers and users of industrial nitrogen. Current analytical methods are referred to, in order to present a readily reproducible system of checking compliance with the requirements of this standard.

Annex A is included as a reminder that safety conditions are paramount. Full details of sampling for analytical purposes are included in BS 5309-2, which includes references to compressed and liquefied gases.

This standard is one of a pair prepared in parallel, the other being BS 4364:1993 *Specification for industrial oxygen*.

Reference to this standard may be made:

- by a purchaser of products;
- by a supplier when specifying products offered;
- by consumer interests and legislative bodies.

The role of a purchaser in monitoring a supplier's compliance with the requirements of this standard may be fulfilled by a third party, such as an accreditation or certification body.

Product certification. Users of this British Standard are advised to consider the desirability of third party certification of product conformity with this British Standard based on testing and continuing product surveillance which may be coupled with assessment of a supplier's quality systems against the appropriate Part of BS 5750.

Enquiries as to the availability of third party certification schemes are forwarded by BSI to the Association of Certification Bodies. If a third party certification scheme does not already exist, users should consider approaching an appropriate body from the list of Association members.

A British Standard does not purport to include all the necessary provisions of a contract. Users of British Standards are responsible for their correct application.

Compliance with a British Standard does not of itself confer immunity from legal obligations.

Summary of pages

This document comprises a front cover, an inside front cover, pages i and ii, pages 1 to 6, an inside back cover and a back cover.

This standard has been updated (see copyright date) and may have had amendments incorporated. This will be indicated in the amendment table on the inside front cover.

1 Scope

This British Standard specifies requirements for nitrogen that is to be used in industrial applications. It also describes the analytical principles and methods to be used to demonstrate compliance with the specification. Requirements for containers and their labelling are also specified.

This standard does not apply to nitrogen for medical, breathing, electronics, or other applications where more demanding impurity limits may apply.

NOTE The nitrogen is referred to hereafter as “the product”.

2 References

2.1 Normative references

This standard incorporates, by reference, provisions from specific editions of other publications. These normative references are cited at the appropriate points in the text and the publications are listed on the inside back cover. Subsequent amendments to, or revisions of, any of these publications apply to this standard only when incorporated in it by updating or revision.

2.2 Informative references

This standard refers to other publications that provide information or guidance. Editions of these publications current at the time of issue of this standard are listed on the inside back cover, but reference should be made to the latest editions.

3 Description

The product shall consist essentially of nitrogen, N_2 , in the form of a compressed gas or a liquid.

NOTE The gaseous product is colourless, odourless and tasteless, and slightly less dense than air at equal temperatures. The liquid product is odourless and colourless, and boils at $-196\text{ }^\circ\text{C}$ at 101.3 kPa pressure. One volume of liquid product gives approximately 678 volumes of gas at $15\text{ }^\circ\text{C}$ and 101.3 kPa.

4 Sampling

For the purpose of sampling the product for analysis, the provisions of BS 5309-2:1976 shall apply.

5 Oxygen content

When determined by the method described in Annex B, the product shall contain a volume fraction of oxygen (O_2) of not more than $15/10^6$ in the gaseous form and not more than $5/10^6$ in the liquid form.

6 Carbon monoxide and carbon dioxide content

When determined by the method described in Annex C, the product shall contain a volume fraction of carbon monoxide (CO) of not more than $5/10^6$ and shall contain a volume fraction of carbon dioxide (CO_2) of not more than $1/10^6$.

7 Total hydrocarbons content

When determined by the method described in Annex D, the product shall contain a volume fraction of hydrocarbons expressed as methane of not more than $1/10^6$.

8 Water content

When determined by the method described in Annex E on a fully charged container, the product shall contain a volume fraction of water of not more than $10/10^6$ in the gaseous form and not more than $2/10^6$ in the liquid form.

NOTE 1 As product is removed from a fully charged container the contribution of water from the container wall may increase.

NOTE 2 Cryogenic liquids do not contain water as such, but may contain ice crystals. The delivery system from a source of liquid product can also contribute water from its surfaces to the product stream.

9 Nitrogen content

After determination of the total content of specified impurities the balance shall consist of nitrogen, plus any traces of noble gases present.

10 Containers

The gaseous product shall be supplied in containers painted in accordance with BS 349:1973.

NOTE 1 For gaseous product attention is drawn to the Pressure Systems and Transportable Gas Containers Regulations, SI 1989 No. 2169[1] and amendments thereof which are currently in force.

NOTE 2 The liquid product is typically supplied in specialized vacuum insulated containers for which there is no British Standard.

11 Labelling

The container in which the product is supplied shall be clearly labelled with the following:

- a) the name, address and registered trade mark of the manufacturer or supplier;
- b) the caption:
“NITROGEN.”

NOTE Attention is drawn to the Classification, Packaging and Labelling of Dangerous Substances Regulations, SI 1984 No. 1244[2] and amendments thereof which are currently in force.

Annex A (informative) Safety considerations for the handling of nitrogen

The product is non-toxic, but constitutes an asphyxiation hazard through the displacement of oxygen in air.

The liquid product and the cold gaseous product can cause severe burns or frostbite when in contact with the skin or respiratory tract.

The product should not be used in confined spaces without ventilation. Personnel should not enter areas enriched with nitrogen.

Annex B (normative) Method for the determination of oxygen content

B.1 Principle

The method uses the principle of electrochemical reduction of any oxygen present in a stream in a detection cell containing either a gel or aqueous solution of electrolyte where the following reactions take place:

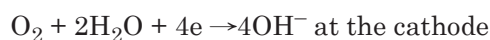

and

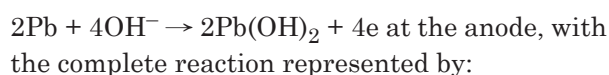

In some instances, electrodes other than lead may be used.

B.2 Apparatus

A variety of analytical equipment suppliers provide simple, ready to run portable units for this purpose, which may be powered either by battery or mains electricity.

Figure B.1 illustrates the configuration of a typical unit designed for this purpose, using aqueous electrolyte.

NOTE 1 Such units require flow to produce any pertinent signal output and to assist in calibration an adsorbent oxygen scrubber is included in the analyser circuit.

Figure B.2 illustrates the configuration of a typical unit designed for this purpose using gel as an electrolyte.

NOTE 2 In this instance any flow variation is not crucial to the measurement.

B.3 Calibration

Calibration of these units shall be carried out using a calibration mixture produced in accordance with BS 4559 and the manufacturer's instructions, and conveyed to the analyser in accordance with BS 5309-2:1976.

B.4 Procedure

After calibrating the instrument, introduce the sample of the product in accordance with the manufacturer's instructions and BS 5309-2:1976. Record the oxygen content that is displayed by the instrument.

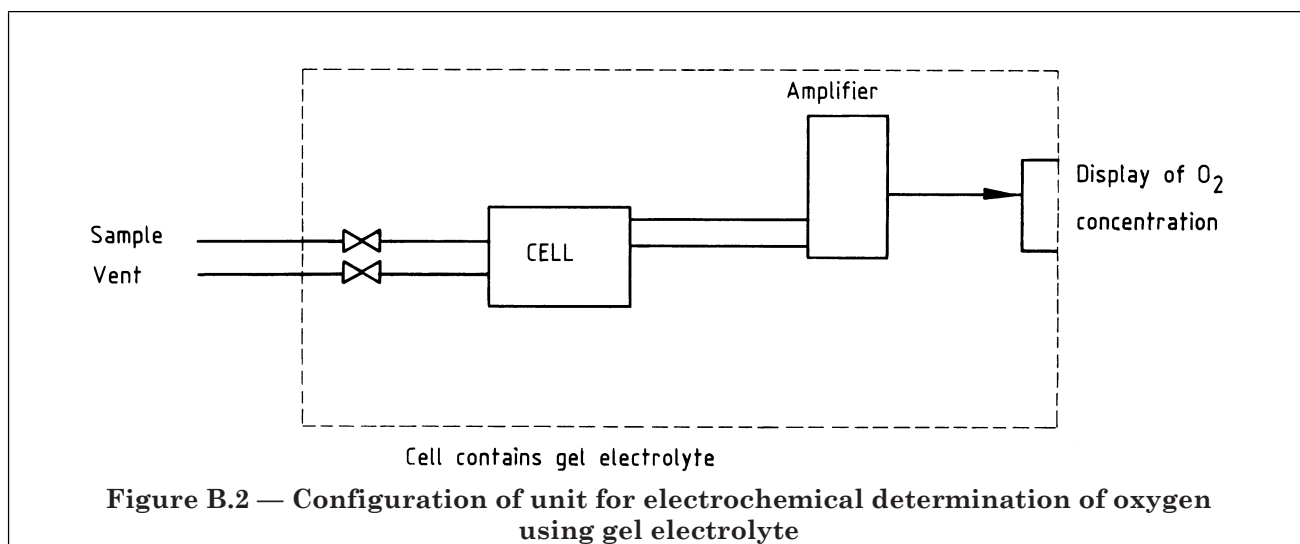
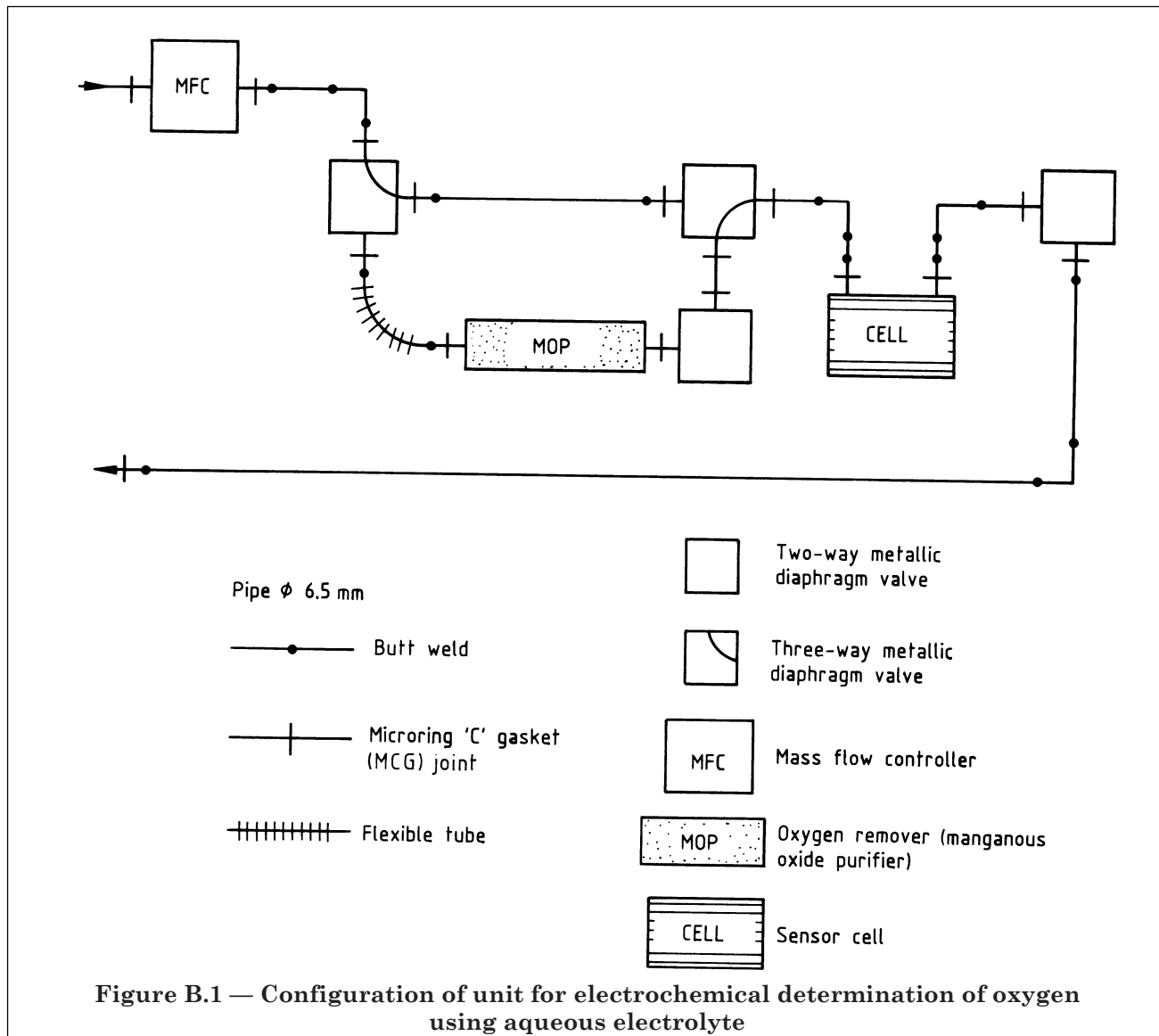

Annex C (normative) Method for the determination of carbon monoxide and carbon dioxide content

C.1 Principle

The method uses the principle of infra-red absorption by different molecules at specific wavelengths in the infra-red spectrum.

C.2 Apparatus

C.2.1 Scanning infra-red spectrometer, complying with BS 4314-1:1968, and fitted with a gas cell of 10 m minimum optical path length.

C.3 Calibration

Calibration of these units shall be carried out using a calibration mixture produced according to BS 4559 and the manufacturer's instructions, and conveyed to the analyser in accordance with BS 5309-2:1976.

C.4 Procedure

After calibrating the instrument, introduce the sample of the product in accordance with the manufacturer's instructions and BS 5309-2:1976. Calculate the carbon monoxide and carbon dioxide contents in accordance with BS 4314-1:1968.

Annex D (normative) Method for the determination of total hydrocarbons content

D.1 Principle

The method uses the principle of ionizing the hydrocarbon molecules that are present in a particular sample in a flame, and monitoring the change in potential across two electrodes in close proximity to the flame, as illustrated in

Figure D.1. The change in potential is proportional to the quantity of hydrocarbons present.

D.2 Apparatus

D.2.1 Gas chromatograph, fitted with a flame ionization detector, a gas sampling valve, and a suitable valve to enable hydrocarbons to be "backflushed" to the detector. Nitrogen carrier gas shall be used.

NOTE While the provisions of BS 5443 will assist with the specification of such a system, many other variables, such as column type, length, carrier flow, detector temperature and oven temperature, may be left open, and still provide a suitable system for determination of this impurity.

D.3 Calibration

Calibration of these units shall be carried out using a calibration mixture produced in accordance with BS 4559 and the manufacturer's instructions, and conveyed to the analyser in accordance with BS 5309-2:1976. The mixture shall, however, contain only methane in a balance of nitrogen, and the result of the calibration shall be expressed as "Total hydrocarbons calibrated as methane".

D.4 Procedure

After calibrating the instrument, introduce the sample of the product in accordance with the manufacturer's instructions and BS 5309-2:1976. Record the output signal on a computing integrator, and calculate the concentration of hydrocarbons in accordance with the computing integrator manufacturer's instructions.

Annex E (normative) Method for the determination of water content

E.1 Principle

The gas is passed through a direct reading hygrometer.

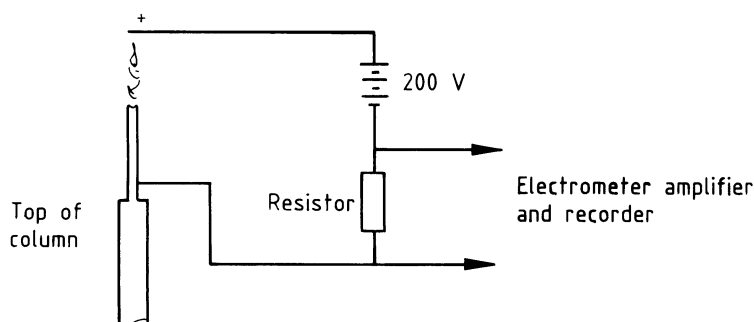

Figure D.1 — Flame ionization detector (schematic)

E.2 Apparatus

E.2.1 A *direct reading hygrometer*, of one of the following types:

- a) cooled mirror dew point;
- b) electrolytic;
- c) capacitance;
- d) piezoelectric.

E.3 Calibration

Ensure that the instrument has a current certificate of calibration demonstrating traceability to the UK national standard held at the National Physical Laboratory.

E.4 Procedure

Operate the direct reading hygrometer in accordance with the manufacturer's instructions. Keep all sample lines as short as practicable and, together with all ancillary equipment, ensure that they have only polytetrafluoroethylene or stainless steel wetted parts. Introduce the sample of the product in accordance with the manufacturer's instructions and BS 5309-2:1976. Record the water content that is displayed by the instrument.

List of references (see clause 2)

Normative references

BSI standards publications

BRITISH STANDARDS INSTITUTION, London

BS 349:1973, *Specification for identification of the contents of industrial gas containers.*

BS 4314, *Specification for apparatus for physical methods of gas analysis.*

BS 4314-1:1968, *Infra-red gas analysers for industrial use.*

BS 4559, *Methods for preparation of calibration gas mixtures.*

BS 4559-1, *Weighing methods.*

BS 4559-1.1:1983, *Mixtures containing components fully vaporizable under ambient conditions.*

BS 4559-3:1983, *Static volumetric methods.*

BS 4559-4:1988, *Certificate of mixture preparation.*

BS 4559-5, *Dynamic volumetric methods.*

BS 4559-5.1:1987, *Review of methods of calibration.*

BS 4559-5.3:1987, *Periodic injections into a flowing gas stream.*

BS 4559-5.4:1987, *Continuous injection method.*

BS 4559-5.6:1987, *Sonic orifices.*

BS 4559-6:1981, *Saturation method.*

BS 4559-7:1981, *Permeation method.*

BS 4559-8:1985, *Mass dynamic method.*

BS 4559-9, *Comparison methods and methods for establishing traceability.*

BS 4559-9.1:1988, *Determination of composition by comparison methods.*

BS 4559-9.2:1988, *Checking by a comparison method.*

BS 5309, *Methods for sampling chemical products.*

BS 5309-2:1976, *Sampling of gases.*

Informative references

BSI standards publications

BRITISH STANDARDS INSTITUTION, London

BS 4364:1993, *Specification for industrial oxygen¹⁾.*

BS 5443:1977, *Recommendations for a standard layout for methods of chemical analysis by gas chromatography.*

BS 5750, *Quality systems¹⁾.*

Other references

[1] GREAT BRITAIN. Pressure Systems and Transportable Gas Containers Regulations, SI 1989 No. 2169. London: HMSO.

[2] GREAT BRITAIN. Classification, Packaging and Labelling of Dangerous Substances Regulations, SI 1984 No. 1244. London: HMSO.

¹⁾ Referred to in the foreword only.

BSI — British Standards Institution

BSI is the independent national body responsible for preparing British Standards. It presents the UK view on standards in Europe and at the international level. It is incorporated by Royal Charter.

Revisions

British Standards are updated by amendment or revision. Users of British Standards should make sure that they possess the latest amendments or editions.

It is the constant aim of BSI to improve the quality of our products and services. We would be grateful if anyone finding an inaccuracy or ambiguity while using this British Standard would inform the Secretary of the technical committee responsible, the identity of which can be found on the inside front cover. Tel: 020 8996 9000. Fax: 020 8996 7400.

BSI offers members an individual updating service called PLUS which ensures that subscribers automatically receive the latest editions of standards.

Buying standards

Orders for all BSI, international and foreign standards publications should be addressed to Customer Services. Tel: 020 8996 9001. Fax: 020 8996 7001.

In response to orders for international standards, it is BSI policy to supply the BSI implementation of those that have been published as British Standards, unless otherwise requested.

Information on standards

BSI provides a wide range of information on national, European and international standards through its Library and its Technical Help to Exporters Service. Various BSI electronic information services are also available which give details on all its products and services. Contact the Information Centre. Tel: 020 8996 7111. Fax: 020 8996 7048.

Subscribing members of BSI are kept up to date with standards developments and receive substantial discounts on the purchase price of standards. For details of these and other benefits contact Membership Administration. Tel: 020 8996 7002. Fax: 020 8996 7001.

Copyright

Copyright subsists in all BSI publications. BSI also holds the copyright, in the UK, of the publications of the international standardization bodies. Except as permitted under the Copyright, Designs and Patents Act 1988 no extract may be reproduced, stored in a retrieval system or transmitted in any form or by any means – electronic, photocopying, recording or otherwise – without prior written permission from BSI.

This does not preclude the free use, in the course of implementing the standard, of necessary details such as symbols, and size, type or grade designations. If these details are to be used for any other purpose than implementation then the prior written permission of BSI must be obtained.

If permission is granted, the terms may include royalty payments or a licensing agreement. Details and advice can be obtained from the Copyright Manager. Tel: 020 8996 7070.