

**BRITISH STANDARD**

---

---

**BS 3951 :  
Part 2 :  
Section 2.3 :  
1992  
ISO 1496-3 :  
1991**

# Freight containers

**Part 2. Specification and testing of series 1 freight containers**

**Section 2.3 Tank containers for liquids, gases and pressurized dry bulk**



**NO COPYING IN ANY FORM WITHOUT WRITTEN PERMISSION FROM BSI**

## Committees responsible for this British Standard

The preparation of this British Standard was entrusted by the Packaging and Freight Containers Standards Policy Committee (PKM/-) to Technical Committee PKM/18, upon which the following bodies were represented:

Associated Offices Technical Committee  
 British Airways  
 British Industrial Truck Association  
 British International Freight Association  
 British Ports Federation  
 British Railways Board  
 Department of Transport (Transport Industries)  
 EEA (The Association of the Electronics, Telecommunications and Business  
 Equipment Industries)  
 General Council of British Shipping  
 Health and Safety Executive  
 Institute of Materials Management  
 Lloyds Register of Shipping  
 Road Haulage Association Ltd.  
 Shipowners Refrigerated Cargo Research Association  
 Society of Motor Manufacturers and Traders Limited

This British Standard, having been prepared under the direction of the Packaging and Freight Containers Standards Policy Committee, was published under the authority of the Standards Board and comes into effect on 1 April 1992

© BSI 1992  
 First published February 1983  
 Second edition April 1992

The following BSI references relate to the work on this standard:  
 Committee reference PKM/18  
 Draft for comment 89/42938 DC

ISBN 0 580 20661 0

### Amendments issued since publication

Amd. No.	Date	Text affected

# Contents

	Page
Committees responsible	Inside front cover
National foreword	ii
Introduction	iii
<b>Specification</b>	
<b>1</b> Scope	1
<b>2</b> Normative references	1
<b>3</b> Definitions	2
<b>4</b> Dimensions and ratings	3
<b>5</b> Design requirements	3
<b>6</b> Testing	6
<b>7</b> Identification and marking	12
<b>Annexes</b>	
<b>A</b> Diagrammatic representation of capabilities appropriate to all types and sizes of tank containers, except where otherwise stated	13
<b>B</b> Details of requirements for load-transfer areas in base structures of containers	17
<b>C</b> Dimensions of grappler-arm lifting areas	23
<b>D</b> Dimensions of gooseneck tunnels	25
<b>E</b> Bibliography	26
<b>Tables</b>	
<b>1</b> Container types	2
<b>2</b> Forces to be applied in stacking test	7

## National foreword

This Section of BS 3951, which is one of a series relating to freight containers, has been prepared under the direction of the Packaging and Freight Containers Standards Policy Committee and supersedes BS 3951 : Part 2 : Section 2.3 : 1983 which is withdrawn.

This Section is identical with ISO 1496-3 : 1991 'Series 1 freight containers — Specification and testing — Part 3 : Tank containers for liquids, gases and pressurized dry bulk' published by the International Organization for Standardization (ISO).

### Cross-references

International standard	Corresponding British Standard
	BS 3951 Freight containers Part 1 General
ISO 668 : 1988	Section 1.1 : 1989 Specification for series 1 freight containers : Classification, dimensions and ratings (Identical)
ISO 830 : 1981	Section 1.4 : 1983 Glossary of terminology (Identical)
ISO 1161 : 1984	Section 1.2 : 1985 Specification for corner fittings for series 1 freight containers (Identical)
ISO 6346 : 1984	Section 1.6 : 1985 Specification for coding, identification and marking (Identical)

Other British Standards giving information on freight containers are BS 5073 : 1982 'Guide to stowage of goods in freight containers' and BS 5237 : 1985 'Specification for lifting twistlocks'.

**Compliance with a British Standard does not of itself confer immunity from legal obligations.**

## Introduction

The following grouping of container types is used for specification purposes in ISO 1496:

Part 1	
General purpose	00 to 09
Specific purpose	
closed, vented/ventilated	10 to 19
open top	50 to 59
Part 2	
Thermal	30 to 49
Part 3	
Tank	70 to 79
Dry bulk, pressurized	85 to 89
Part 4	
Bulk, non-pressurized (box type)	20 to 24
Bulk, non-pressurized (hopper type)	80 to 84
Part 5	
Platform (container)	60
Platform-based with incomplete superstructure and fixed ends	61 and 62
Platform-based with incomplete superstructure and folding ends	63 and 64
Platform-based with complete superstructure	65 to 69

NOTE 1 Containers types 90 to 99 are reserved for air/surface containers (see ISO 8323).

## Series 1 freight containers — Specification and testing —

### Part 3:

### Tank containers for liquids, gases and pressurized dry bulk

#### 1 Scope

1.1 This part of ISO 1496 specifies the basic specifications and testing requirements for ISO series 1 tank containers suitable for the carriage of gases, liquids and solid substances (dry bulk) which may be loaded or unloaded as liquids by gravity or pressure discharge, for international exchange and for conveyance by road, rail and sea, including interchange between these forms of transport.

1.2 Except where otherwise stated, the requirements of this part of ISO 1496 are minimum requirements. Tank containers to be used for the carriage of dangerous goods may be subject to additional international and national requirements as applied by competent authorities.

1.3 The container types covered by this part of ISO 1496 are given in table 1.

1.4 The marking requirements for these containers shall be in accordance with the principles embodied in ISO 6346.

#### 2 Normative references

The following standards contain provisions which, through reference in this text, constitute provisions of this part of ISO 1496. At the time of publication, the editions indicated were valid. All standards are subject to revision, and parties to agreements based on this part of ISO 1496 are encouraged to investigate the possibility of applying the most recent editions of the standards indicated below. Members of IEC and ISO maintain registers of currently valid International Standards.

ISO 668:1988, *Series 1 freight containers — Classification, dimensions and ratings*.

ISO 830:1981, *Freight containers — Terminology*, and its amendments: ISO 830:1981/Amd.1:1984 and ISO 830:1981/Amd.2:1988.

ISO 1161:1984, *Series 1 freight containers — Corner fittings — Specification*.

ISO 6346:1984, *Freight containers — Coding, identification and marking*, and its amendment: ISO 6346:1984/Amd.1:1988.

## ISO 1496-3:1991(E)

Table 1 — Container types

Type of cargo and ISO type code designation <sup>1)</sup>					Minimum test pressure <sup>2)</sup> bar gauge <sup>3)</sup>	Code basis			
Liquids		Gases	Dry bulk			UN MM	IMO/IMDG tank type		
Non-dangerous	Dangerous		Horizontal discharge	Tipping discharge			2	1	5
70 <sup>4)</sup>					0,45				
71	73		85	87	1,5	+	+		
72	74		86	88	2,65	+	+	+	
	75				4	+		+	
	76				6	+		+	
		77			10 (10,5)	+		+	(+)
		78			22				
		79			Open				

NOTE — For all containers, other than 1D and 1DX, it is essential that the design requirements of 5.1.5 are also taken into consideration.

1) The ISO type code designation does not imply the approval of any competent authority for the transport of specific goods or products the tank container may carry. The type code depends only on the test pressure (see 6.13).

2) The test pressure given is the minimum value of the respective class. Any tank container with a test pressure in the range between a given minimum pressure and the next higher minimum pressure belongs to the lower class.

3) 1 bar = 100 kPa. Test pressure is expressed in bars since relevant intergovernmental codes, often implemented by national legislation, retain this unit of pressure.

4) The number 70 may, in addition, be used to designate tank containers for which the type code relevant to the test pressure is not used.

### 3 Definitions

For the purposes of this part of ISO 1496, the definitions given in ISO 830, together with the following, apply. However, for practical reasons, certain definitions taken and adapted from ISO 830 are given below.

**3.1 tank container:** Freight container which includes two basic elements, the tank or tanks and the framework, and complies with the requirements of this part of ISO 1496.

**3.2 framework:** Tank mountings, end structure and all load-bearing elements not present for the purposes of containing cargo, which transmit static and dynamic forces arising out of the lifting, handling, securing and transporting of the tank container as a whole.

**3.3 tank or tanks:** The vessel or vessels and associated piping and fittings which are designed to contain the cargo carried.

**3.4 compartment:** A section of the tank formed by the shell, ends or complete bulkheads.

NOTE 2 Baffles, surge plates or other perforated plates do not form tank compartments within the meaning of this definition.

**3.5 gas:** Fluid substance having a vapour pressure greater than an absolute pressure of 300 kPa<sup>1)</sup> at 50 °C or as otherwise defined by the competent authority.

**3.6 liquid:** Fluid substance having a vapour pressure not greater than an absolute pressure of 300 kPa<sup>1)</sup> at 50 °C.

**3.7 dry bulk:** Assemblies of separate solid particles normally substantially in contact with one another which are, or may be rendered, capable of fluid flow.

**3.8 dangerous goods:** Those substances classified as dangerous by the United Nations committee of experts on the transport of dangerous goods or by the competent authority as defined in 3.9.

**3.9 competent authority:** The authority or authorities designated as such in each country or in each specific case by the governments concerned for the approval of tank containers.

1) 300 kPa = 3 bar

**3.10 maximum allowable working pressure:** That pressure assigned for operation by either a competent authority or other responsible person to a particular tank, above which that tank is not intended to be operated.

**3.11 test pressure:** The gauge pressure at which the tank is tested (see 6.13.2).

**3.12 total capacity:** That volume of water which will completely fill the tank at 20 °C.

**3.13 ullage:** That portion of the total capacity of the tank not occupied by its cargo, expressed as a percentage of the total capacity.

## 4 Dimensions and ratings

### 4.1 External dimensions

The overall external dimensions and tolerances of tank containers covered by this part of ISO 1496 shall be those established in ISO 668, except that tank containers may be of reduced height, in which case they shall be designated 1AX, 1BX, 1CX and 1DX. No part of the tank container, its associated fittings and/or equipment shall project beyond these specified overall external dimensions.

### 4.2 Ratings

The values of the rating  $R$ , the maximum gross mass of the container, shall be those specified in ISO 668. However, taking account of the high density of many fluid cargoes, the values of the rating  $R$  chosen for the design and testing of 1BB, 1B, 1CC and 1C tank containers may be higher than those specified in ISO 668. For all containers in operation, such values shall in no case exceed the rating allowed for 1AA and 1A containers in ISO 668.

## 5 Design requirements

### 5.1 General

All tank containers shall be capable of fulfilling the following requirements for the framework, the design and construction of the tank and any optional provisions.

**5.1.1** The ability of the tank container to withstand the specified design loadings shall be established by calculation or test.

**5.1.2** The strength requirements for tank containers are given in diagrammatic form in annex A (these requirements are applicable to all tank containers as complete units except where otherwise stated).

2) See 6.1.1, note 6.

**5.1.3** The strength requirements for corner fittings (see also 5.2) are specified in ISO 1161.

**5.1.4** The tank container shall be capable of withstanding the test loads and loadings specified in clause 6.

**5.1.5** Each tank container shall be designed to withstand the effects of inertia of the tank contents resulting from transport motions. For design purposes, these effects may be taken to be equivalent to loadings of  $2Rg$  longitudinally,  $Rg$  laterally and  $2Rg$  vertically<sup>2)</sup>. These loadings may be considered individually to be evenly distributed and to act through the geometric centre of the tank. Vertical loadings are total loadings including dynamic effects. It should be noted that the above loadings do not give rise to an increase in pressure in the vapour space. For design purposes, an equivalent pressure loading may be used.

**5.1.6** Each tank container shall be capable of withstanding the requirements of 5.1.5 and the static head produced in the tank container while loaded to its rating  $R$ . Due regard shall be given to the liquid/dry bulk of highest density that is to be carried and to any compartmentation of the tank.

**5.1.7** As the effects of loads encountered under any dynamic operating condition should only approach, but not exceed, the effects of the corresponding test loads, it is implicit that the capabilities of tank containers indicated in annex A and demonstrated by the tests described in clause 6 shall not be exceeded in any mode of operation.

**5.1.8** Any closure in a tank container, which if unsecured could lead to a dangerous situation, shall be provided with an adequate securing system having, so far as may be practicable, external indication of the positive securement of that closure in the appropriate operating position.

**5.1.9** Fork-lift pockets shall not be provided in tank containers.

**NOTE 3** Fork-lift transport of tank containers is considered dangerous because of stability problems with loaded or partly-loaded tanks and the danger of impact damage from the forks of fork-lift trucks.

**5.1.10** The tank container materials shall be suitable for, or adequately protected from, the cargo and the environment in which the tank container may be operated.

Due regard should be given to the problems of variation in ambient temperature, corrosive atmos-



## ISO 1496-3:1991(E)

pheres, the possibility of uncontrolled cargo release in fire, etc.

## 5.2 Corner fittings

### 5.2.1 General

All tank containers shall be equipped with top and bottom corner fittings. The requirements and positioning of the corner fittings are given in ISO 1161. The upper faces of the top corner fittings shall protrude above the top of all other components of the tank container by a minimum of 6 mm<sup>3)</sup> (see 5.3.5).

### 5.2.2 Doubler plates

Whenever reinforced zones or doubler plates are provided to afford protection in the vicinity of the top corner fittings, such plates and their securements shall not protrude above the upper faces of the top corner fittings. These plates shall not extend more than 750 mm<sup>3)</sup> from either end of the container but may extend the full width.

## 5.3 Base structure

**5.3.1** All tank containers shall be capable of being supported by their bottom corner fittings only.

**5.3.2** All tank containers, other than 1D and 1DX, shall be capable of being supported only by load-transfer areas in their base structure.

**5.3.2.1** Consequently, these tank containers shall have end transverse members and sufficient intermediate load-transfer areas (or a flat underside) of sufficient strength to permit vertical load transfer to or from the longitudinal members of a carrying vehicle, which are assumed to lie within the two 250 mm<sup>3)</sup> wide zones defined by the dotted lines in figure B.1.

**5.3.2.2** The lower faces of the load-transfer areas in the container base structure, including those of the end transverse members, shall lie in one plane located

$$12,5 \text{ mm } \begin{matrix} +5 \\ -1,5 \end{matrix} \text{ mm}^3$$

above the plane of the lower faces of the bottom corner fittings of the tank container (base plane).

Apart from the bottom corner fittings and bottom side rails, no part of the container shall project below this plane. However, doubler plates may be

provided in the vicinity of the bottom corner fitting to afford protection to the understructure.

Such plates shall not extend more than 550 mm<sup>3)</sup> from the outer end and not more than 470 mm<sup>3)</sup> from the side faces of the bottom corner fittings, and their lower faces shall be at least 5 mm<sup>3)</sup> above the lower faces of the base plane of the container.

**5.3.2.3** The transfer of load between the underside of any bottom side rails which may be fitted and carrying vehicles is not envisaged.

The transfer of load between side rails and handling equipment should only occur when provision has been made in accordance with 5.7.1.

**5.3.2.4** Load-transfer area requirements are given in annex B.

**5.3.3** For 1D and 1DX tank containers, the level of the underside of the base structure is not specified, except insofar as it is implied in 5.3.4 and 5.3.5.

**5.3.4** When the tank container is loaded to its rating *R*, no part of the tank or its associated shell fittings shall project downwards below a plane situated 25 mm<sup>3)</sup> above the base plane (bottom faces of the bottom corner fittings).

**5.3.5** For tank containers under dynamic conditions, or the static equivalent thereof, with the tank container loaded in such a way that the combined mass of the tank container and test load is equal to 1,8*R*, no part of the base of the tank container shall deflect more than 6 mm<sup>3)</sup> below the base plane (bottom faces of the bottom corner fittings).

## 5.4 End structure

For tank containers other than 1D and 1DX, the sideways deflection of the top of the tank container with respect to the bottom of the tank container at the time it is under full transverse rigidity test conditions (see 6.8) shall not cause the sum of the changes in length of the two diagonals to exceed 60 mm<sup>3)</sup>.

## 5.5 Side structure

For tank containers other than 1D and 1DX, the longitudinal deflection of the top of the tank container with respect to the bottom of the tank container at the time it is under full longitudinal rigidity test conditions (see 6.9) shall not exceed 25 mm<sup>3)</sup>.

3) 5 mm = 3/16 in; 6 mm = 1/4 in; 12,5 mm  $\begin{matrix} +5 \\ -1,5 \end{matrix}$  mm = 1/2 in  $\begin{matrix} +3/16 \\ -1/16 \end{matrix}$  in; 25 mm = 1 in; 60 mm = 2 3/8 in; 250 mm = 10 in; 470 mm = 18 1/2 in; 550 mm = 22 in; 750 mm = 29 1/2 in

## 5.6 Tank

### 5.6.1 Design and construction

**5.6.1.1** Each tank or compartment thereof shall be designed and constructed to good technical practice.

**5.6.1.2** Each tank or tanks shall be firmly secured to structural elements of the tank framework. The tank or tanks shall be capable of being filled and emptied without removal from the framework.

**5.6.1.3** Tanks or tank compartments without vacuum relief devices shall be designed to withstand an external pressure of at least 40 kPa<sup>4)</sup> above the internal pressure.

Tanks equipped with vacuum relief valves shall be designed to withstand an external overpressure of 21 kPa<sup>4)</sup> or greater.

### 5.6.2 Corrosion allowance

In addition to the requirements of 5.1.10, an allowance for corrosion shall be taken into consideration where necessary.

### 5.6.3 Tank openings

**5.6.3.1** All tank openings except those fitted with pressure relief devices shall be provided with adequate closures to prevent accidental escape of the contents.

**5.6.3.2** Tank nozzles and outlet fittings shall be substantially made and attached to the tank in such a manner as to minimize the risk of breakage. Protective covers or housings shall be used wherever necessary to comply with this requirement (see 4.1 and 5.3).

**5.6.3.3** Any tank opening located below the normal level of the contents and fitted with a valve capable of being operated manually shall be provided with an additional means of closure on the outlet side of the valve. Such additional means of closure may be a contents-tight cap, bolted blank flange, or other suitable protection against accidental escape of the contents.

All valves, whether fitted internally or externally, shall be located as close to the tank shell as practicable.

**5.6.3.4** Stop valves with screwed spindles shall be closed by clockwise motion of the handwheel.

**5.6.3.5** All tank connections, such as nozzles, outlet fittings and stop valves, shall be clearly marked to indicate their appropriate functions.

### 5.6.4 Pressure and vacuum relief devices

**5.6.4.1** Each tank or compartment thereof intended to carry non-dangerous cargo shall be fitted with a pressure relief device set to be fully open at a pressure not greater than the tank's test pressure, to prevent excessive internal overpressure. Such devices shall be connected to the vapour space of the tank and located as near to the top of the tank and as near to the tank's (or tank compartment's) mid-length as practicable.

In those cases where the tank container is used with both dangerous and non-dangerous cargo, the relief devices shall be set in accordance with 5.6.4.3.

**5.6.4.2** Pressure relief devices, installed as required in 5.6.4.1, should have a minimum relief capacity of 0,05 m<sup>3</sup>/s<sup>4)</sup> of standard air [an absolute pressure of 100 kPa<sup>4)</sup> at 15 °C].

This may be considered as providing overpressure protection under non-emergency conditions, but should not be considered as adequate protection for a tank container, or compartment thereof, against excessive overpressure under full fire exposure conditions, dry bulk dust explosion or higher dry bulk pressurization.

**5.6.4.3** Tanks, or a compartment thereof, intended for the carriage of dangerous goods shall be provided with pressure relief devices meeting the relevant regulations to the satisfaction of the competent authority.

**5.6.4.4** Each pressure relief device shall be plainly and permanently marked with the pressure at which it is set to operate.

**5.6.4.5** A tank container, or a compartment thereof, with an external design pressure of less than 40 kPa<sup>4)</sup> shall be equipped with a vacuum relief device set to relieve at an absolute pressure of 79 kPa<sup>4)</sup>, except that a lower absolute setting may be used, provided that the external design pressure is not exceeded. The vacuum relief device shall have a minimum through area of 284 mm<sup>2</sup><sup>4)</sup> and shall conform to the requirements of the competent authority. The use of combination pressure/vacuum relief devices is allowed.

**NOTE 4** The above requirements are intended to protect against collapse of the tank, or compartment thereof, during conditions of normal ambient temperature variations. They will not necessarily prevent collapse if a tank, or a compartment thereof, is, for example, closed tightly

4) 21 kPa = 0,21 bar; 40 kPa = 0,4 bar; 79 kPa = 0,79 bar; 100 kPa = 1 bar; 284 mm<sup>2</sup> = 0,44 in<sup>2</sup>; 0,05 m<sup>3</sup>/s = 106 ft<sup>3</sup>/min

**ISO 1496-3:1991(E)**

immediately after steam cleaning or discharged without opening the manhole covers.

**5.6.5 Inspection and maintenance openings**

Tank containers shall be provided with manholes or other openings to allow for complete internal inspection, unless exempted by the competent authority.

The size of manholes shall be a minimum of 500 mm<sup>5)</sup> in diameter and shall be determined by the need for men and machines to enter the tank to inspect, maintain, or repair the inside, taking into account the requirements of the governing competent authority.

**5.6.6 Gauging devices**

Gauging devices which may be in direct communication with the contents of the tank shall not be made of easily destructible material.

**5.6.7 Sealing (customs requirements)**

Adequate provision shall be made for the sealing of the tank in accordance with international customs agreements.

**5.7 Requirements — Optional features****5.7.1 Provisions for handling at the base by means of grapples or similar devices**

Provision for handling tank containers by means of grapples or similar devices may be provided as optional features.

The dimensional requirements for such provisions are specified in annex C.

**5.7.2 Gooseneck tunnels**

Gooseneck tunnels may be provided as optional features in 1AA, 1A and 1AX tank containers. The dimensional requirements are specified in annex D and, in addition, all other parts of the base structure shall be as specified in 5.3.

**5.7.3 Walkways**

Where provided, walkways shall be designed to withstand a load of 300 kg<sup>5)</sup> uniformly distributed over an area of 600 mm × 300 mm<sup>5)</sup>.

**5.7.4 Ladders**

Where provided, ladders shall be designed to withstand a load of 200 kg<sup>5)</sup> on any rung.

**5.7.5 Tank insulation**

When insulation is provided, the design and construction shall be such that the insulation will in no way impinge on the specified requirements nor interfere with the proper function of the tank fittings.

Due regard shall be given to the requirements of 5.1.10.

**5.7.6 Tank heating and refrigeration**

When heating or refrigeration is provided, due consideration shall be given to the safety of the tank and its contents. Suitable safeguards shall be provided to avoid the development of excessive temperature and stresses.

**6 Testing****6.1 General**

Unless otherwise stated, tank containers complying with the design and construction requirements specified in clause 5 shall, in addition, be capable of withstanding the tests specified in 6.2 to 6.11. The pressure test (test No. 12) shall be applied to every tank container and shall, where practicable, be carried out last if other tests are to be performed.

Tank containers intended for the carriage of dangerous goods shall, in addition, comply with the test requirements of the relevant regulations to the satisfaction of the competent authority.

NOTE 5 Dynamic tests are not included pending possible development of a satisfactory and reproducible test specification.

6.1.1 The symbol  $P$  denotes the maximum payload of the container to be tested, that is,

$$P = R - T$$

where

$R$  is the rating;

$T$  is the tare.

The symbol  $W$  denotes the container payload with the total capacity filled with water.

NOTE 6  $R$ ,  $P$ ,  $T$  and  $W$ , by definition, are in units of mass. Where test requirements are based on the gravitational forces derived from these values, those forces, which are inertial forces, are indicated thus:

$$R_g, P_g, T_g, W_g$$

5) 200 kg = 440 lb; 300 kg = 660 lb; 500 mm = 19 3/4 in; 600 mm × 300 mm = 24 in × 12 in

the units of which are in newtons or multiples thereof.

The word "load", when used to describe a physical quantity to which units may be ascribed, implies mass.

The word "loading", for example, as in "internal loading", implies force.

**6.1.2** The tank container under test, unless otherwise stated, shall be loaded with a suitable fluid/dry bulk to achieve the test load or loading specified.

If the test load or loading cannot readily be met by the above method, or if such a method is undesirable, the tank container shall be loaded with a suitable fluid/dry bulk and a supplementary load or loading shall be applied. The total load or loading thus applied shall be such as to simulate uniform loading.

Variations of 20 % of the calculated bending moment diagrams of the uniformly loaded tank container shall be considered acceptable.

**NOTE 7** Other alternative test load or loadings (for example for longitudinal and lateral internal restraint tests) may be used, provided that they achieve the specified test loading.

**6.1.3** The test loads and loadings specified for all the following tests are minimum requirements.

**NOTE 8** Special attention is drawn to the loading induced during operation of types 87 and 88.

**6.1.4** The dimensional requirements to which reference is made in the requirements clause after each test are those specified in

- a) the dimensional and design requirement clauses 4 and 5 of this part of ISO 1496;
- b) ISO 668;
- c) ISO 1161.

## 6.2 Test No. 1 — Stacking

### 6.2.1 General

This test shall be carried out to prove the ability of a tank container to support a superimposed mass of containers, taking into account conditions aboard ships at sea and the relative eccentricities between superimposed containers.

Table 2 specifies the force to be applied as a test to each pair of corner fittings and the superimposed mass that the test force represents.

### 6.2.2 Procedure

The tank container, filled completely with water, shall be placed on four level pads, one under each bottom corner fitting. The pads shall be centralized under the fittings and shall be substantially of the same plan dimensions as the fittings.

The tank container shall be subjected to vertical forces applied either to all four corner fittings simultaneously, or to each pair of end fittings, at the appropriate level specified in table 2.

The forces shall be applied through a test fixture equipped with corner fittings as specified in ISO 1161, or equivalent fittings which have imprints of the same geometry (i.e. with the same external dimensions, chamfered aperture and rounded edges) as the bottom face of the bottom corner fitting specified in ISO 1161. If equivalent fittings are used, they shall be designed to produce the same effect on the container under test loads as when corner fittings are used.

In all cases, the forces shall be applied in such a manner that rotation of the planes through which the forces are applied and on which the container is supported, is minimized.

**Table 2 — Forces to be applied in stacking test**

Container designation	Test force per container (all four corners simultaneously)		Test force per pair of end fittings		Superimposed mass represented by test force	
	kN	lbf	kN	lbf	kg	lb
1AA, 1A and 1AX	3 392	763 200	1 696	381 600	192 000	423 320
1BB, 1B and 1BX	3 392	763 200	1 696	381 600	192 000	423 320
1CC, 1C and 1CX	3 392	763 200	1 696	381 600	192 000	423 320
1D and 1DX	896	201 600	448	100 800	50 800	112 000

**NOTE** — The test force of 3392 kN per container is derived from the superimposed mass of nine-high stacking, i.e. eight containers stacked on top of one container, all being rated to 24 000 kg, and an acceleration of 1.8g. [The corner posts of such containers are known as having been tested to 86 400 kg (190 480 lb).]

## ISO 1496-3:1991(E)

Each corner fitting or equivalent fitting shall be offset in the same direction by 25,4 mm<sup>6)</sup> laterally and 38 mm<sup>6)</sup> longitudinally.

In the case of tank containers with identical ends, only one end need be tested.

### 6.2.3 Requirements

On completion of the test, the tank container shall not show leakage or permanent deformation or abnormality which will render it unsuitable for use, and the dimensional requirements affecting handling, securing and interchange shall be satisfied.

## 6.3 Test No. 2 — Lifting from the four top corner fittings

### 6.3.1 General

This test shall be carried out to prove the ability of a tank container, other than a 1D or a 1DX container, to withstand being lifted from the four top corner fittings with the lifting forces applied vertically, and the ability of a 1D or 1DX tank container to withstand being lifted from the four top corner fittings with the lifting forces applied at any angle between the vertical and 60° to the horizontal. These are the only recognized ways of lifting tank containers by the four top corner fittings.

This test shall also be regarded as proving the ability of the tank container to withstand the forces arising from acceleration of the payload in lifting operations.

### 6.3.2 Procedure

The tank container under test shall be loaded in such a way that the combined mass of tank container and test load is equal to 2R (see 6.1.2) and it shall be carefully lifted from all four top corners in such a way that no significant acceleration or deceleration forces are applied.

For a tank container other than 1D or 1DX, the lifting forces shall be applied vertically.

For a 1D or 1DX tank container, lifting shall be by means of slings, the angle of each leg being at 60° to the horizontal.

After lifting, the tank container shall be suspended for 5 min and then lowered to the ground.

### 6.3.3 Requirements

On completion of the test, the tank container shall not show leakage or permanent deformation or

abnormality which will render it unsuitable for use, and the dimensional requirements affecting handling, securing and interchange shall be satisfied.

## 6.4 Test No. 3 — Lifting from the four bottom corner fittings

### 6.4.1 General

This test shall be carried out to prove the ability of a tank container to withstand being lifted from its four bottom corner fittings by means of lifting devices bearing on the bottom corner fittings only and attached to a single transverse central spreader beam above the container.

### 6.4.2 Procedure

The tank container under test shall be loaded in such a way that the combined mass of tank container and test load is equal to 2R (see 6.1.2), and shall be carefully lifted from the side apertures of all four bottom corner fittings in such a way that no significant acceleration or deceleration forces are applied.

Lifting forces shall be applied at

30° to the horizontal for 1AA, 1A and 1AX tank containers;

37° to the horizontal for 1BB, 1B and 1BX tank containers;

45° to the horizontal for 1CC, 1C and 1CX tank containers;

60° to the horizontal for 1D and 1DX tank containers.

In each case, the line of action of the lifting force and the outer face of the corner fitting shall be no further apart than 38 mm<sup>6)</sup>. The lifting shall be carried out in such a manner that the lifting devices bear on the four bottom corner fittings only.

The tank container shall be suspended for 5 min and then lowered to the ground.

### 6.4.3 Requirements

On completion of the test, the tank container shall not show leakage or permanent deformation or abnormality which will render it unsuitable for use, and the dimensional requirements affecting handling, securing and interchange shall be satisfied.

6) 25,4 mm = 1 in; 38 mm = 1 1/2 in

## 6.5 Test No. 4 — External restraint (longitudinal)

### 6.5.1 General

This test shall be carried out to prove the ability of a tank container to withstand longitudinal external restraint under dynamic conditions of railway operation, which implies accelerations of 2g.

### 6.5.2 Procedure

The tank container shall be loaded in such a way that the combined mass of tank container and test load is equal to  $R$  (see 6.1.2), and shall be secured longitudinally to rigid anchor points through the bottom apertures of the bottom corner fittings at one end of the tank container.

A force of  $2Rg$  shall be applied horizontally to the tank container through the bottom apertures of the other bottom corner fittings, first towards and then away from the anchor points.

### 6.5.3 Requirements

On completion of the test, the tank container shall not show leakage or permanent deformation or abnormality which will render it unsuitable for use, and the dimensional requirements affecting handling, securing and interchange shall be satisfied.

## 6.6 Test No. 5 — Internal restraint (longitudinal)

### 6.6.1 General

Separate tests shall be carried out to prove the ability of the tank container to withstand the effects of the inertia of the tank contents both on the tank itself and the tank-to-framework connections under the conditions of longitudinal acceleration envisaged in 5.1.

#### NOTES

9 The effects of vertical acceleration are deemed to be covered by tests No. 2 and No. 3.

10 Containers without longitudinal frames are deemed to be covered by test No. 4.

### 6.6.2 Procedure

The tank container shall be loaded in such a way that the combined mass of the tank container and test load is equal to  $R$ .

The tank container shall be positioned with its longitudinal axis vertical (a tolerance of  $3^\circ$  is acceptable). It shall be held in this position for 5 min either

a) by means of supports at the lower end of the base structure of the tank container acting only through the two bottom corner fittings giving both vertical and horizontal securement, and by means of anchor devices acting through the corner fittings at the upper end of the base structure in such a manner as to provide horizontal restraint only; or

b) by means of supports under the four downward-facing corner fittings.

Alternative procedure b) may be used only for those types of tank containers where the tank is supported solely by the base structure of the container or where, in the opinion of the competent authority, the tank container is adequately tested with respect to tank-to-framework connections by tests No. 4 and No. 8.

Tank containers which are not structurally symmetrical with respect to internal divisions or tank-to-framework connections shall be tested at both ends.

### 6.6.3 Requirements

On completion of the tests, the tank container shall not show leakage or permanent deformation or abnormality which will render it unsuitable for use, and the dimensional requirements affecting handling, securing and interchange shall be satisfied.

## 6.7 Test No. 6 — Internal restraint (lateral)

### 6.7.1 General

Separate tests shall be carried out to prove the ability of the tank container to withstand the effects of the inertia of the tank contents both on the tank itself and the tank-to-framework connections under the conditions of lateral acceleration envisaged in 5.1.

#### NOTES

11 The effects of vertical acceleration are deemed to be covered by tests No. 2 and No. 3.

12 Containers without longitudinal frames are deemed to be covered by test No. 4.

### 6.7.2 Procedure

The tank container shall be loaded in such a way that the combined mass of the tank container and test load is equal to  $R$ .

The tank container shall be positioned with its transverse axis vertical (a tolerance of  $3^\circ$  is acceptable). It shall be held in this position for 5 min either

## ISO 1496-3:1991(E)

- a) by means of supports at the lower end of the base structure of the tank container acting only through the two bottom corner fittings given both vertical and horizontal securement, and by means of anchor devices acting through the corner fittings at the upper end of the base structure in such a manner as to provide horizontal restraint only; or
- b) by means of supports under the four downward-facing corner fittings.

Alternative procedure b) may be used only for those types of tank containers where the tank is supported solely by the base structure of the container or where, in the opinion of the competent authority, the tank container is adequately tested with respect to tank-to-framework connections by tests Nos. 4 and 8.

### 6.7.3 Requirements

On completion of the tests, the tank container shall not show leakage or permanent deformation or abnormality which will render it unsuitable for use, and the dimensional requirements affecting handling, securing and interchange shall be satisfied.

## 6.8 Test No. 7 — Rigidity (transverse)

### 6.8.1 General

This test shall be carried out to prove the ability of a tank container, other than a 1D or a 1DX container, to withstand the transversal racking forces resulting from ship movement.

### 6.8.2 Procedure

The tank container in tare condition (*T*) shall be placed on four level supports, one under each corner fitting, and shall be restrained against lateral and vertical movement by means of anchor devices acting through the bottom apertures of the bottom corner fittings. Lateral restraint shall be provided only at a bottom corner fitting diagonally opposite to and in the same end frame as a top corner fitting to which force is applied.

When testing the two end frames separately, vertical restraint need only be applied at the end frame under test.

Forces of 150 kN<sup>7)</sup> shall be applied either separately or simultaneously to each of the top corner fittings on one side of the tank container in lines parallel both to the base and to the planes of the ends of the tank container. The forces shall be applied first towards and then away from the top corner fittings.

7) 75 kN = 16 850 lbf; 150 kN = 33 700 lbf

In the case of tank containers with identical ends, only one end need be tested. Where an end is not essentially symmetrical about its own vertical centre line, both sides of that end shall be tested.

For allowable deflection under full test loading, see 5.4.

### 6.8.3 Requirements

On completion of the test, the tank container shall not show leakage or permanent deformation or abnormality which will render it unsuitable for use, and the dimensional requirements affecting handling, securing and interchange shall be satisfied.

## 6.9 Test No. 8 — Rigidity (longitudinal)

### 6.9.1 General

This test shall be carried out to prove the ability of a tank container, other than a 1D or a 1DX container, to withstand the longitudinal racking forces resulting from ship movement.

### 6.9.2 Procedure

The tank container in tare condition (*T*) shall be placed on four level supports, one under each corner fitting, and shall be restrained against longitudinal and vertical movement by means of anchor devices acting through the bottom apertures of the bottom corner fittings. Longitudinal restraint shall be provided only at a bottom corner fitting diagonally opposite and in the same side frame as a top corner fitting to which the force is applied.

Forces of 75 kN<sup>7)</sup> shall be applied either separately or simultaneously to each of the top corner fittings on one end of the tank container in lines parallel both to the base of the tank container and to the planes of the sides of the tank container. The force shall be applied first towards and then away from the top corner fittings.

In the case of a tank container with identical sides, only one side need be tested. Where a side is not essentially symmetrical about its own vertical centre line, both ends of that side shall be tested.

For allowable deflections under full test loadings, see 5.5.

### 6.9.3 Requirements

On completion of the test, the tank container shall not show leakage or permanent deformation or abnormality which will render it unsuitable for use, and the dimensional requirements affecting handling, securing and interchange shall be satisfied.

## 6.10 Test No. 9 — Lifting from the base at grappler-arm positions (where provided)

### 6.10.1 General

This test shall be carried out on any tank container with fixtures for being lifted by grappler arms or similar devices with lifting positions as detailed in annex C.

### 6.10.2 Procedure

The tank container shall be loaded in such a way that the combined mass of the container and test load is equal to  $1,25R$ , and it shall be supported at the four positions where provision has been made for the equipment specified in 6.10.1 over an area of  $32 \text{ mm} \times 254 \text{ mm}^8$  centrally located at each of the four positions, clear of the safety lips.

The tank container shall be supported for 5 min and then lowered to the ground.

### 6.10.3 Requirements

On completion of the test, the tank container shall not show leakage or permanent deformation or abnormality which will render it unsuitable for use, and the dimensional requirements affecting handling, securing and interchange shall be satisfied.

## 6.11 Test No. 10 — Walkways (where provided)

### 6.11.1 General

This test shall be carried out on all walkways, where provided on a tank container, to prove the ability of the walkway to withstand the loads imposed by persons working thereon.

### 6.11.2 Procedure

A concentrated load of not less than  $300 \text{ kg}^8$  shall be uniformly distributed over an area of  $600 \text{ mm} \times 300 \text{ mm}^8$  located at the weakest area of the walkway.

### 6.11.3 Requirements

On completion of the test, the walkways shall show neither undue deformation nor any abnormality which renders them unsuitable for use.

## 6.12 Test No. 11 — Ladders (where provided)

### 6.12.1 General

This test shall be carried out on all ladders, where provided on a tank container, to prove the ability of the ladder to withstand the loads imposed by persons working thereon.

### 6.12.2 Procedure

A load of  $200 \text{ kg}^8$  shall be positioned at the centre of the widest rung.

### 6.12.3 Requirements

On completion of the test, the ladders shall show neither undue deformation nor abnormality which would render them unsuitable for use.

## 6.13 Test No. 12 — Pressure test

### 6.13.1 General

This test shall be carried out on every tank container to prove the ability of the tank to withstand the specified internal pressure. Where practicable, it shall be carried out last if other tests are to be performed, but before the addition of thermal insulation, if any.

Shot-blasting or other preparation normally required prior to applying lining or insulation need not be performed prior to this test.

### 6.13.2 Procedure

The tank shall be hydraulically tested.

If the liquid/gas tank is provided with compartments, in addition to hydraulic testing, each compartment shall be tested with the adjacent compartments empty and at atmospheric pressure.

The test pressure shall be measured at the top of the tank or compartment with the tank container in its normal position. The test pressure shall be maintained for as long as is necessary to enable a complete examination of the tank and its fittings to be made, but in any case for not less than 30 min.

Relief devices, where fitted, shall be rendered inoperative or removed for the purpose of this test.

The pressure at which the tank is tested shall be selected with regard to the intended use of the tank, in accordance with the regulations applied by the competent authority and the requirements of 5.1.6. This pressure will determine the type code design-

8)  $200 \text{ kg} = 440 \text{ lb}$ ;  $300 \text{ kg} = 660 \text{ lb}$ ;  $32 \text{ mm} \times 254 \text{ mm} = 1 \frac{1}{4} \text{ in} \times 10 \text{ in}$ ;  $600 \text{ mm} \times 300 \text{ mm} = 24 \text{ in} \times 12 \text{ in}$



**ISO 1496-3:1991(E)**

nation of the tank container in accordance with table 1.

**6.13.3 Requirements**

During the test, the tank shall show no leakage. On completion of the test, the tank container shall not show leakage or permanent deformation or abnormality which will render it unsuitable for use, and the dimensional requirements affecting handling, securing and interchange shall be satisfied.

**7 Identification and marking**

**7.1** The marking requirements for these tank containers shall be in accordance with the principles embodied in ISO 6346 for the identification and marking of freight containers.

**7.2** At least the following data allowing tank identification shall be permanently attached to the tank in a readily accessible position. These data shall be permanently marked by stamping, emboss-

ing or other means and shall not be painted so as to obscure the markings:

- a) date of original hydraulic test, year and month;
- b) test pressure, in kilopascals and bars;
- c) maximum allowable working pressure, in kilopascals and bars;
- d) total capacity, in litres;
- e) date of hydraulic re-test, year and month;
- f) type code designation (optional mark).

**7.3** As far as possible, the data plate shall include the information required by the competent authorities, thus reducing to a minimum the number of separate plates required. All data plates should be located as close to one another as possible.

If any of the required data is included on other data plates, it need not be duplicated in order to satisfy the requirements of this International Standard.

## Annex A (normative)

### Diagrammatic representation of capabilities appropriate to all types and sizes of tank containers, except where otherwise stated

#### NOTES

13 The externally applied forces shown below are for one end or one side only. The loads shown within the containers represent uniformly distributed internal loads only, and such loads are for the whole container.

14 The figures in this annex correspond to the tests described in 6.2 to 6.12 only where marked.

15 For definitions of  $R$ ,  $P$ ,  $T$  and  $W$ , see 6.1.1.

Figure No.	End elevations	Side elevations
A.1	<p>Stacking Test No. 1</p> <p style="text-align: center;">Not applicable to 1D and 1DX tank containers</p>	
A.1.A	<p>Stacking Test No. 1</p> <p style="text-align: center;">Applicable to 1D and 1DX tank containers only</p>	
A.2	<p>Top lift</p>	
A.3	<p>Top lift Test No. 2</p> <p style="text-align: center;">Not applicable to 1D and 1DX containers</p>	

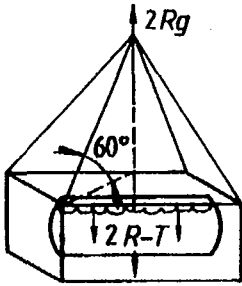
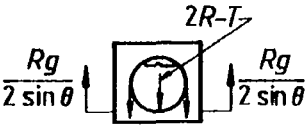
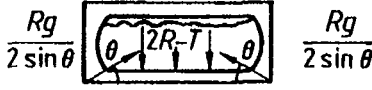
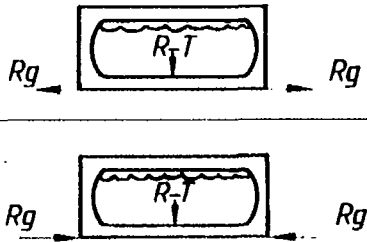
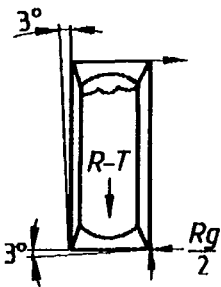
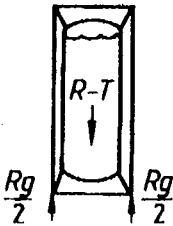
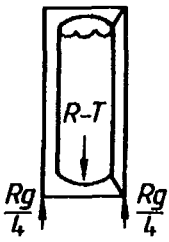
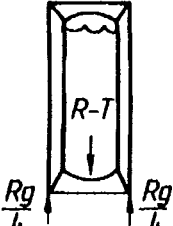
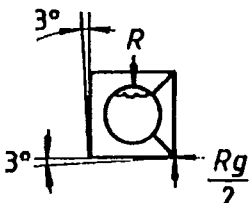
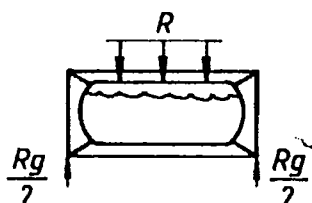
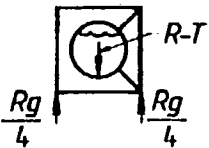
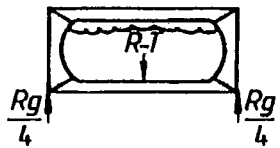
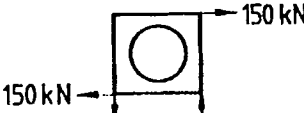
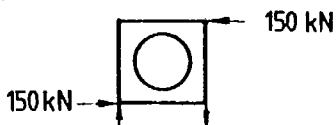
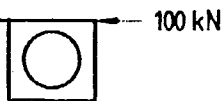
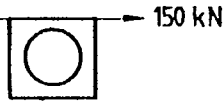
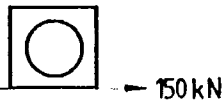

Figure No.	End elevations	Side elevations
A.4	<p>Top lift Test No. 2</p>  <p>Applicable to 1D and 1DX tank containers only</p>	
A.5	<p>Bottom lift Test No. 3</p>  <p>Applicable to all tank containers</p>	
A.6	<p>External restraint (longitudinal) Test No. 4</p> <p>Applicable to all tank containers</p>	
A.7	<p>Internal restraint (longitudinal) Test No. 5 [see 6.6.2 a)]</p>  <p>Tank-frame connections through all corner fittings</p>	
A.8	<p>Internal restraint (longitudinal) Test No. 5 [see 6.6.2 b)]</p>  <p>Tank-frame connections through bottom structure only</p>	

Figure No.	End elevations	Side elevations
A.9	Internal restraint (lateral) Test No. 6 [see 6.7.2 a)] 	
A.10	Internal restraint (lateral) Test No. 6 [see 6.7.2 b)]  <p style="text-align: center;">Tank-frame connections through bottom structure only</p>	
A.11	Rigidity (transverse) Test No. 7 	} Applicable to all tank containers except 1D and 1DX
A.12	Rigidity (transverse) Test No. 7 	
A.13	Lashing/securement 	
A.14	Lashing/securement 	
A.15	Lashing/securement 	
A.16	Lashing/securement 	

ISO 1496-3:1991(E)

Figure No.	End elevations	Side elevations
A.17	Rigidity (longitudinal) Test No. 8	
A.18	Applicable to all tank containers except 1D and 1DX	
A.19	Lashing/securement (This type of loading is not permissible except as applied in A.4.)	
A.20	Lashing/securement	

Optional features

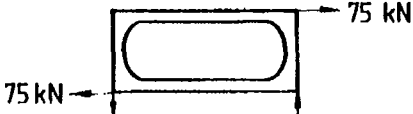
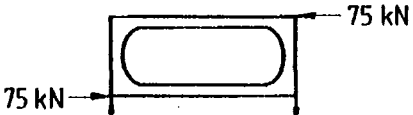
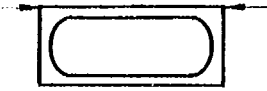
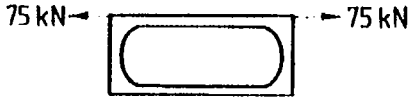
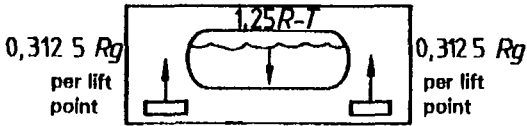
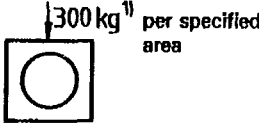
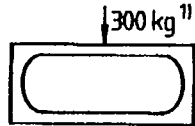
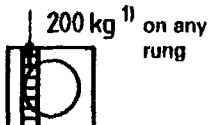
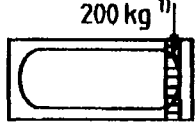
A.21	Grappler-arm lift Test No. 9  When fitted with grappler-arm lift positions	
A.22	Walkways Test No. 10    Applies to all tank containers (where walkways are provided)	
A.23	Ladders Test No. 11    Applies to all tank containers (where ladders are provided)	
1) 300 kg = 660 lb 200 kg = 440 lb		

## Annex B (normative)

### Details of requirements for load-transfer areas in base structures of containers

**B.1** The base structures of containers, i.e. the end transverse members and such intermediate members as may be fitted (or such flat undersides as may be provided) to constitute load-transfer areas, shall be capable of transferring load to or from the longitudinal members of a carrying vehicle which are assumed to lie within the two 250 mm<sup>9)</sup> wide zones defined (by the broken lines) in figure B.1.

**B.2** Containers having transverse members spaced more than 1 000 mm<sup>9)</sup> apart (and not having a flat underside) shall have load-transfer areas as indicated in figures B.2, B.3, B.4 and B.5, capable of meeting the following requirements.

**B.2.1** Each pair of load-transfer areas associated with an end transverse member shall be capable of transferring loads of not less than  $0,5R$ , i.e. the loads which may occur when a container is placed onto a carrying vehicle of the kind which does not support the container by its corner fittings.

Furthermore, each pair of intermediate load-transfer areas shall be capable of transferring loads of not less than  $1,5R/n$ , where  $n$  is the number of pairs of intermediate load-transfer areas, i.e. loads which may occur during transport operations.

**B.2.2** The minimum number of pairs of load-transfer areas are:

For 1CC, 1C and 1CX containers	4
For 1BB, 1B and 1BX containers	5

For 1AA, 1A and 1AX containers	5
--------------------------------	---

For 1AA, 1A and 1AX containers fitted with a non-continuous gooseneck tunnel	6
--	---

Where a greater number of pairs of load-transfer areas are provided, these should be approximately equally spaced along the length of the container.

**B.2.3** The spacing between the end transverse member and the nearest intermediate pair of load-transfer areas shall be:

- 1 700 mm to 2 000 mm<sup>9)</sup> for containers having the minimum number of pairs of load-transfer areas for the container concerned;
- 1 000 mm to 2 000 mm<sup>9)</sup> for containers having one more pair of load-transfer areas than the minimum required for the containers concerned.

**B.2.4** Each load-transfer area shall have a longitudinal dimension of at least 25 mm<sup>9)</sup>.

**B.3** Minimum requirements for load-transfer areas in the vicinity of the gooseneck tunnel are shown in figure B.6.

NOTE 16 In figures B.2, B.3, B.4 and B.5, the load-transfer areas associated with the container base are shown in black. Gooseneck tunnel transfer areas are also shown in black in figure B.6.

9) 25 mm = 1 in; 250 mm = 10 in; 1 000 mm = 39 3/8 in; 1 000 mm to 2 000 mm = 39 3/8 in to 78 3/4 in; 1 700 mm to 2 000 mm = 66 15/16 in to 78 3/4 in

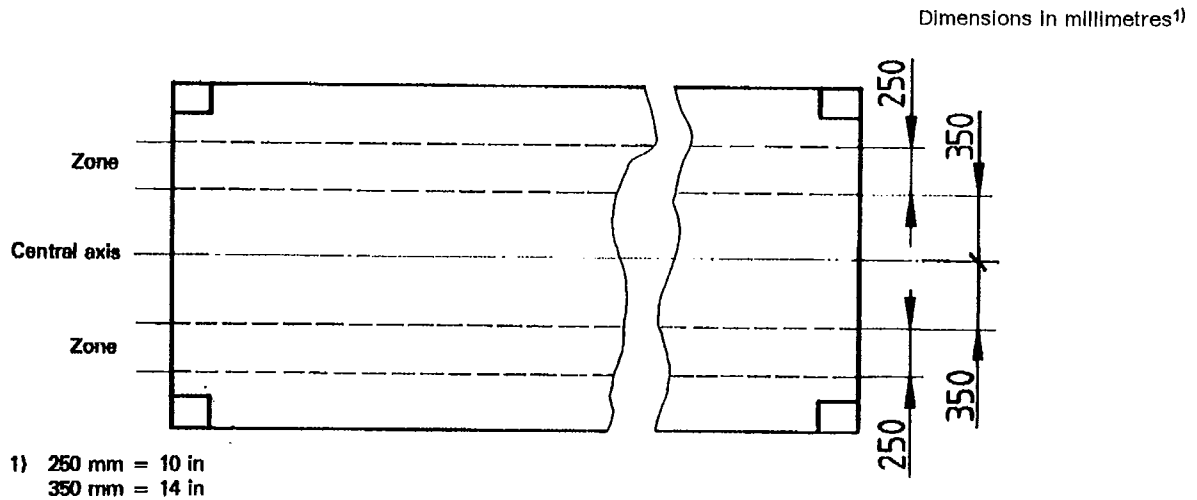
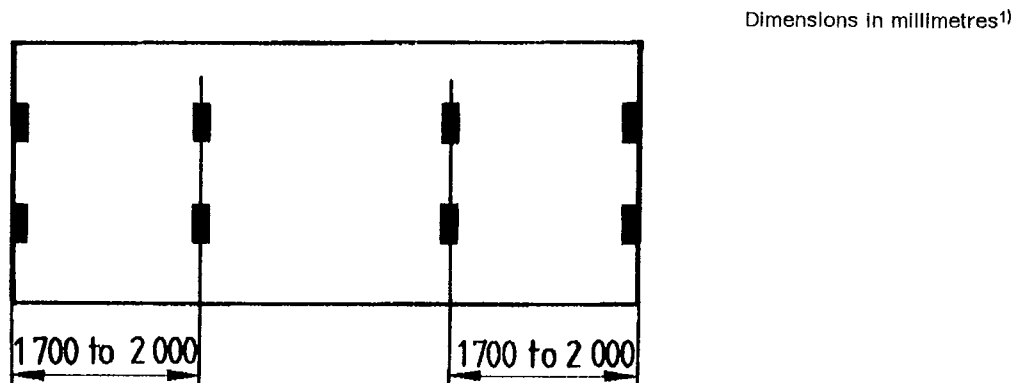
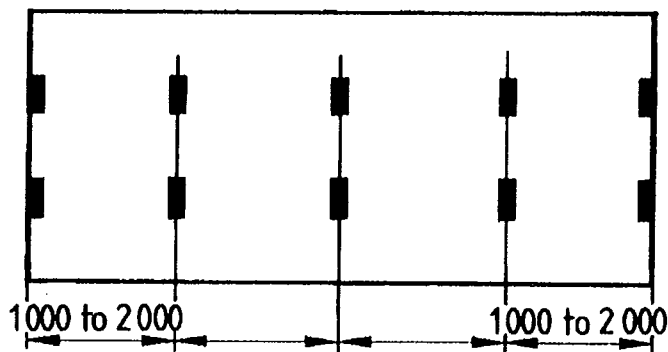

Figure B.1 — Zones for longitudinal members



4 pairs of load-transfer areas  
(1 pair at each end plus 2 intermediate pairs)

a) Minimum requirements



b) Requirements applicable if 5 pairs of load-transfer areas are to be fitted

- 1) 1 700 mm to 2 000 mm = 66 15/16 in to 78 3/4 in
- 1 000 mm to 2 000 mm = 39 3/8 in to 78 3/4 in

Figure B.2 — 1CC, 1C and 1CX containers

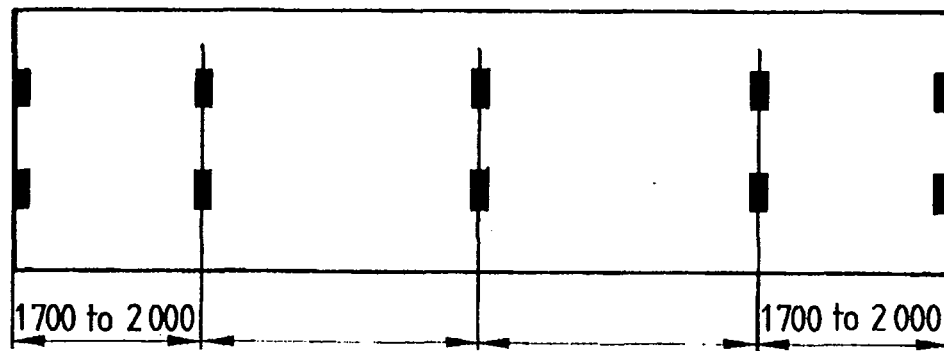
Dimensions in millimetres<sup>1)</sup>

5 pairs of load-transfer areas  
(1 pair at each end plus 3 intermediate pairs)

**a) Minimum requirements**

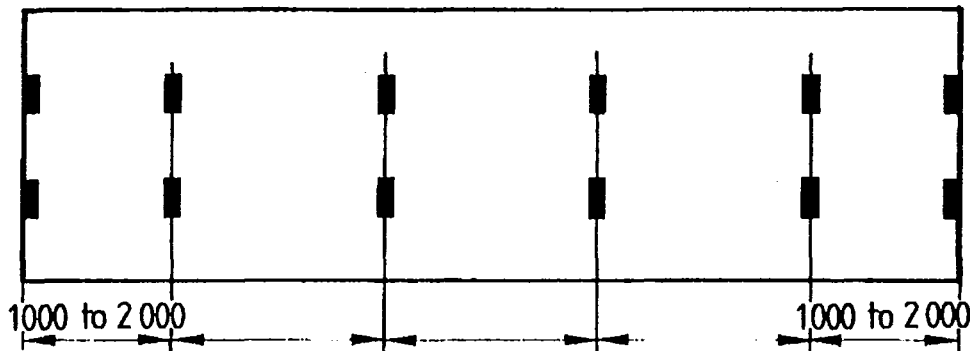

**b) Requirements applicable if 6 pairs of load-transfer areas are to be fitted**

- 1) 1 700 mm to 2 000 mm = 68 15/16 in to 78 3/4 in  
1 000 mm to 2 000 mm = 39 3/8 in to 78 3/4 in

**Figure B.3 — 1BB, 1B and 1BX containers**

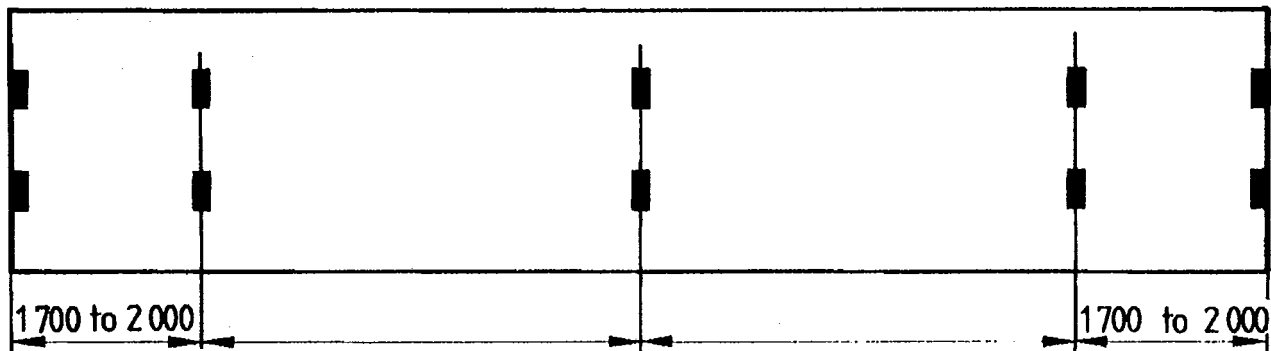

Dimensions in millimetres<sup>1)</sup>

5 pairs of load-transfer areas  
(1 pair at each end plus 3 intermediate pairs)

**a) Minimum requirements**

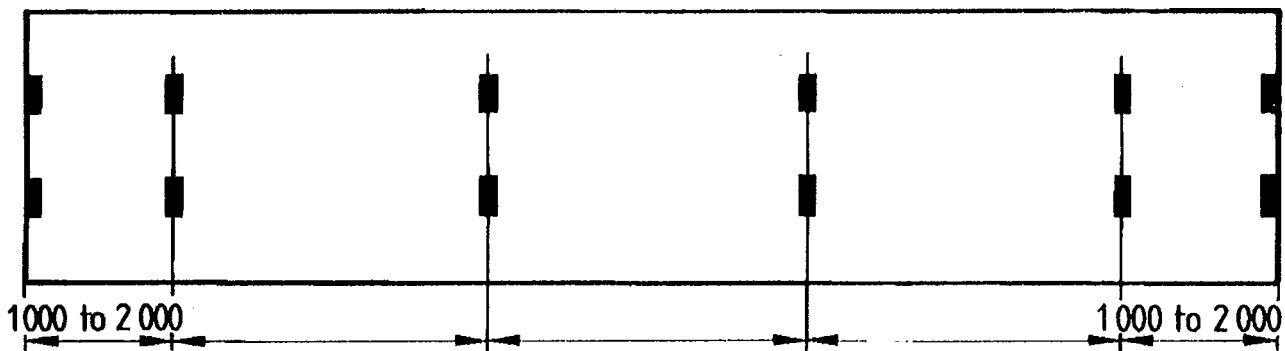

**b) Requirements applicable if 6 pairs of load-transfer areas are to be fitted**

- 1) 1 700 mm to 2 000 mm =  $66\frac{15}{16}$  in to  $78\frac{3}{4}$  in  
1 000 mm to 2 000 mm =  $39\frac{3}{8}$  in to  $78\frac{3}{4}$  in

**Figure B.4 — 1AA, 1A and 1AX containers without gooseneck tunnel**

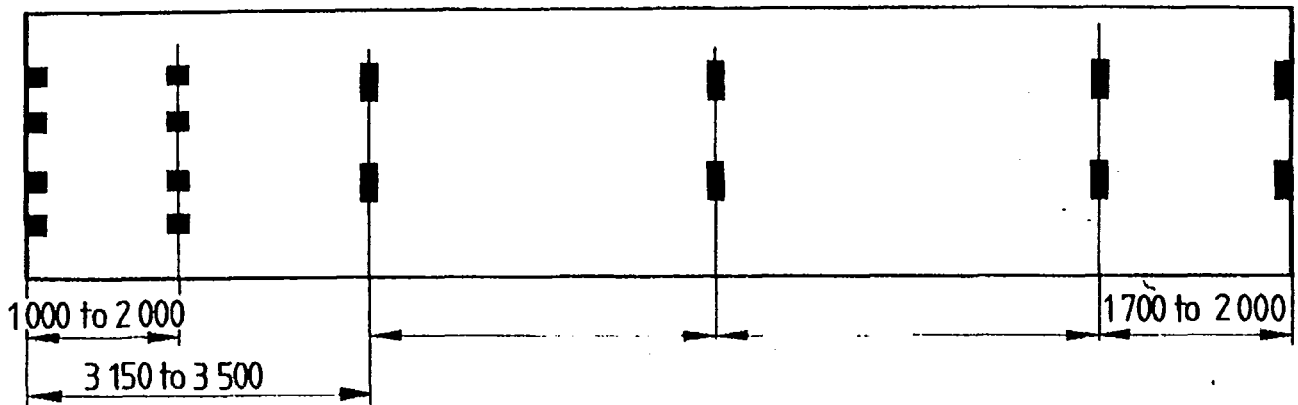
Dimensions in millimetres<sup>1)</sup>

(See also figure B.6)

6 pairs of load-transfer areas  
(1 pair at each end plus 4 intermediate pairs)

**a) Minimum requirements**

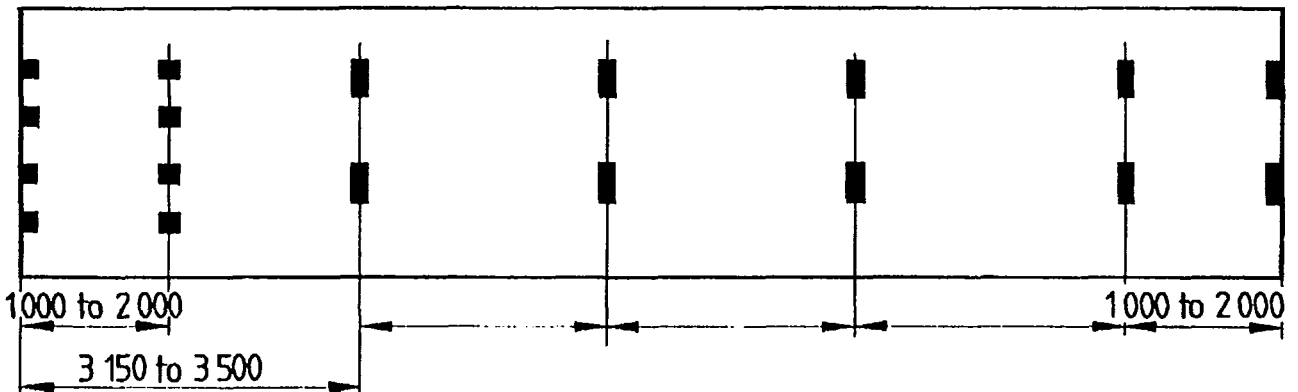

(See also figure B.6)

**b) Requirements applicable if 7 pairs of load-transfer areas are to be fitted**

- 1) 1 000 mm to 2 000 mm = 39<sup>3</sup>/<sub>8</sub> in to 78<sup>3</sup>/<sub>4</sub> in
- 1 700 mm to 2 000 mm = 66<sup>15</sup>/<sub>16</sub> in to 78<sup>3</sup>/<sub>4</sub> in
- 3 150 mm to 3 500 mm = 124<sup>1</sup>/<sub>4</sub> in to 137<sup>7</sup>/<sub>8</sub> in

Figure B.5 — 1AA, 1A and 1AX containers with gooseneck tunnel (with minimum localized structure)

Dimensions in millimetres<sup>1)</sup>

Each load-transfer area at the tunnel has two components, an upper component (A) and a lower component (B). This paired set, A and B, shall be taken as one load-transfer area and the sum of the two components, A + B, shall be equal to or greater than 1 250 mm<sup>2</sup>.

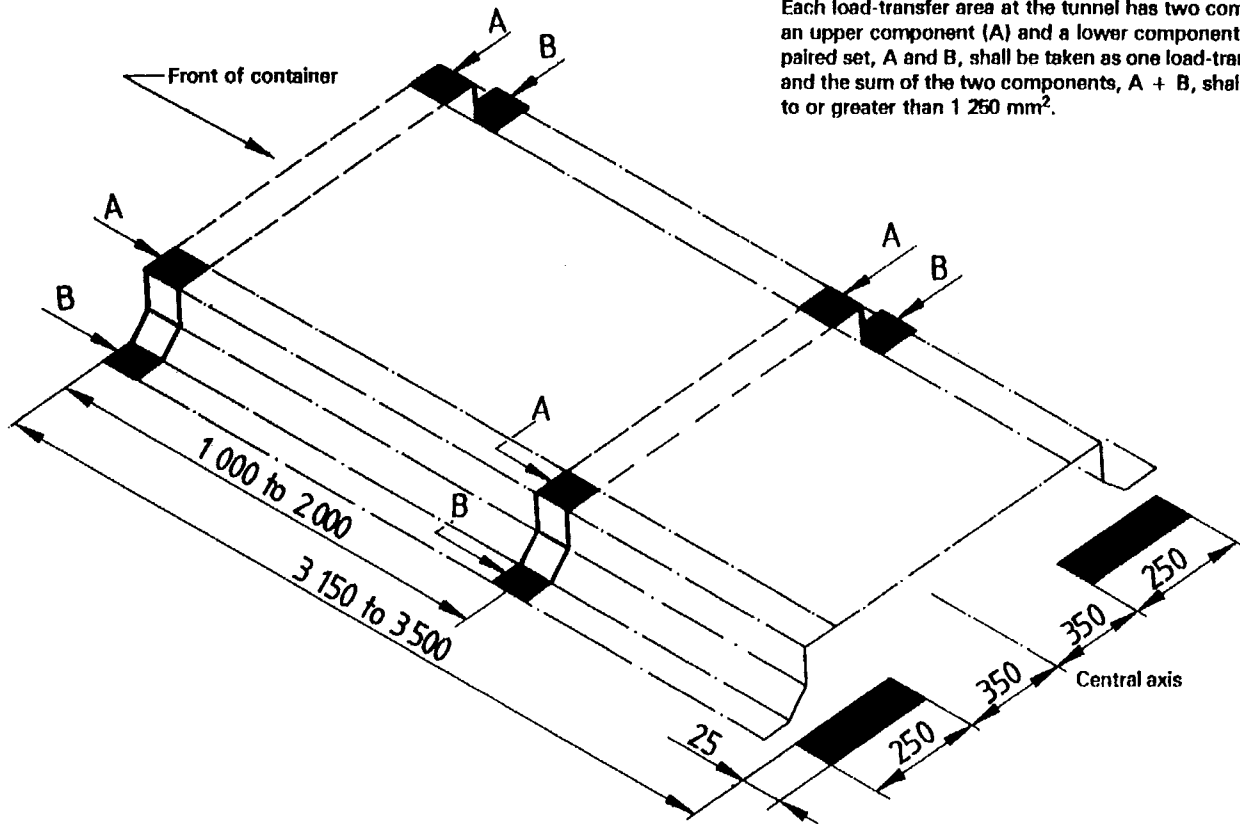

(See annex D for details of tunnel section.)

NOTE — Where continuous tunnel side members are provided, the load-transfer areas situated between 3 150 mm and 3 500 mm<sup>1)</sup> from the end of the container may be omitted.

1) 1 250 mm<sup>2</sup> = 2 in<sup>2</sup>

1 000 mm to 2 000 mm = 39 3/8 in to 78 3/4 in

3 150 mm to 3 500 mm = 124 1/4 in to 137 7/8 in

25 mm = 1 in

250 mm = 10 in

350 mm = 14 in

Figure B.6 — Minimum requirements for load-transfer areas near the gooseneck tunnel

**Annex C**  
(normative)

**Dimensions of grappler-arm lifting areas (where provided)**

See 5.7.1 and figure C.1.

Copyrighted material

Dimensions in millimetres

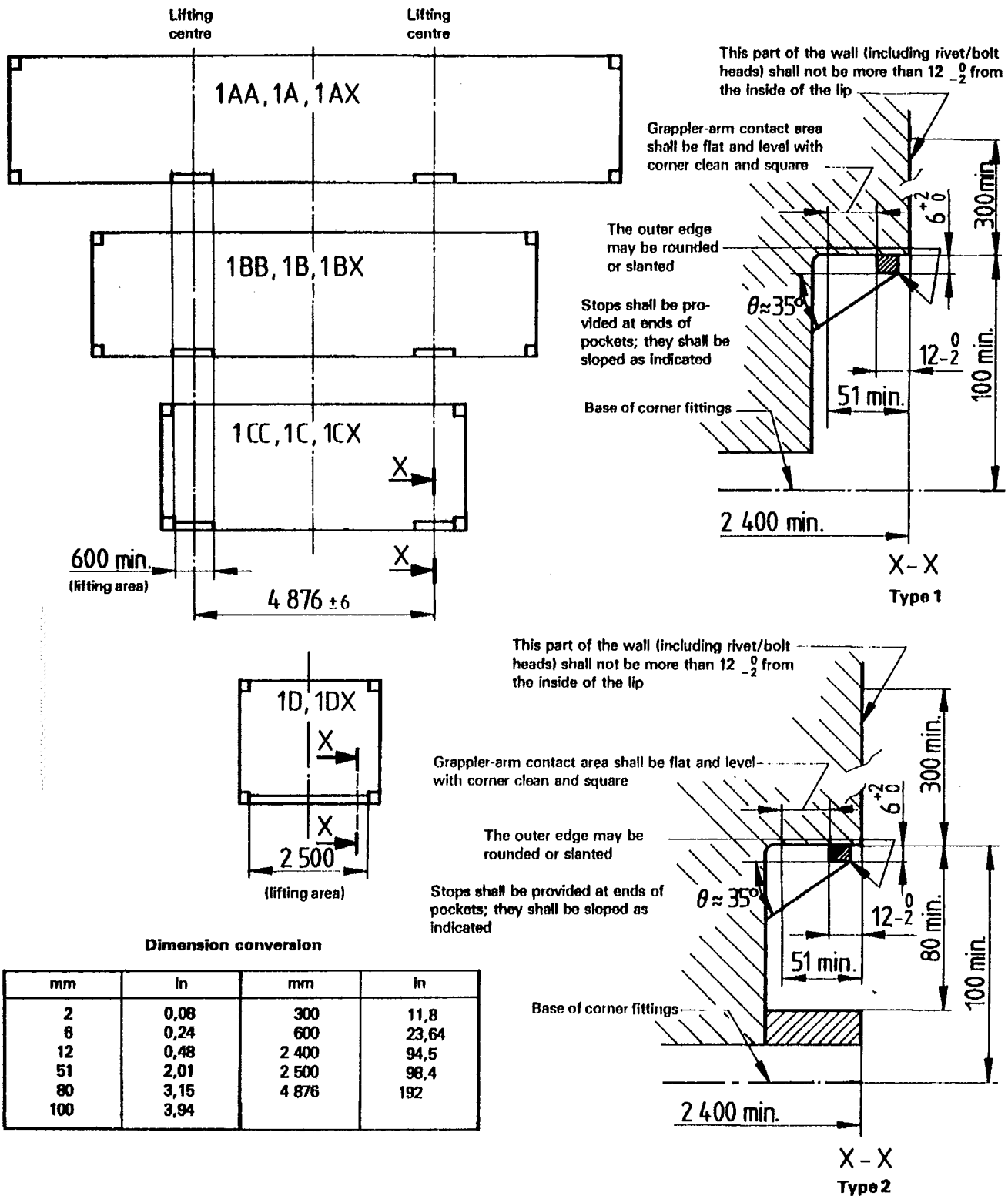
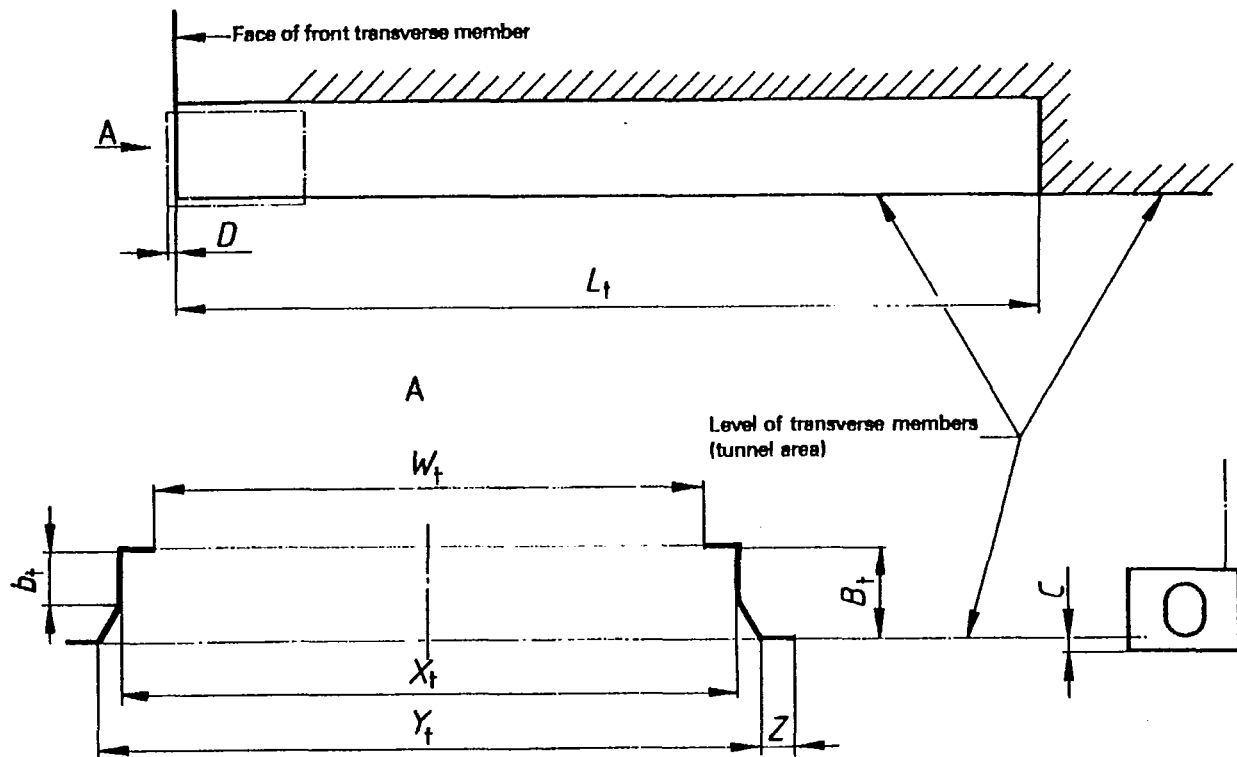

Figure C.1

## Annex D (normative)

### Dimensions of gooseneck tunnels (where provided).

See 5.7.2. The space required to constitute a gooseneck tunnel into which the gooseneck of a trailer may fit is shown in figure D.1.



Dimensions	Length		Width				Height		
	$L_1$	$D$	$W_t$ , max.	$X_t$	$Y_t$	$Z$ , min.	$B_t$	$b_t$	$C$
mm	3 500 3 150	$6^{+1}_{-2}$	930	$1\ 029^{+3}_0$	1 130 1 070	25	$120^0_{-3}$	70 35	$12,5^{+5}_{-1,5}$
in	$137\ 7/8$ $124\ 1/4$	$1/4^{+3/64}_{-3/32}$	$36\ 5/8$	$40\ 1/2^{+1/8}_0$	$44\ 1/2$ $42\ 1/8$	1	$4\ 23/32^0_{-1/8}$	$2\ 3/4$ $1\ 3/8$	$1/2^{+3/16}_{-1/16}$

#### NOTES

- 1 Tolerance  $B_t$  shall be measured in the back part of the tunnel, over a length of about 600 mm (23 5/8 in).
- 2 The tunnel structure may be formed by continuous members having the minimum length specified in the table and the internal dimensions given for the thick lines in the figure or, alternatively, localized structures may be provided at the positions shown in black in figure B.6.

Figure D.1

**Annex E**  
(informative)

**Bibliography**

- [1] ISO 8323:1985, *Freight containers — Air/surface (intermodal) general purpose containers — Specification and tests.*

**Publication(s) referred to**

See national foreword.



**BS 3951 :**  
**Part 2 :**  
**Section 2.3 :**  
**1992**  
**ISO 1496-3 :**  
**1991**

---

---

## **BSI — British Standards Institution**

BSI is the independent national body responsible for preparing British Standards. It presents the UK view on standards in Europe and at the international level. It is incorporated by Royal Charter.

### **Contract requirements**

A British Standard does not purport to include all the necessary provisions of a contract. Users of British Standards are responsible for their correct application.

### **Revisions**

British Standards are updated by amendment or revision. Users of British Standards should make sure that they possess the latest amendments or editions.

Any person who finds an inaccuracy or ambiguity while using this British Standard should notify BSI without delay so that the matter may be investigated swiftly.

BSI offers members an individual updating service called PLUS which ensures that subscribers automatically receive the latest editions of standards.

### **Buying British Standards**

Orders for all British Standard publications should be addressed to the Sales Department at Milton Keynes.

### **Information on standards**

BSI provides a wide range of information on national, European and international standards through its Library, the Standardline Database, the BSI Information Technology Service (BITS) and its Technical Help to Exporters Service. Contact Customer Information at Milton Keynes: Tel: 0908 221166.

Subscribing members of BSI are kept up to date with standards developments and receive substantial discounts on the purchase price of standards. For details of these and other benefits contact the Manager, Membership Development at Milton Keynes: Tel: 0908 220022.

### **Copyright**

Copyright subsists in all BSI publications. No part of this publication may be reproduced in any form without the prior permission in writing of BSI. This does not preclude the free use, in the course of implementing the standard, of details such as symbols and size, type or grade designations. Enquiries about copyright should be made to the Copyright Manager, Publications at Milton Keynes.

BSI  
2 Park Street  
London  
W1A 2BS

BSI  
Linford Wood  
Milton Keynes  
MK14 6LE