

BRITISH STANDARD 3506 : 1969

UDC 621.643.29 : 678.743

SPECIFICATION FOR
UNPLASTICIZED
PVC PIPE
FOR INDUSTRIAL USES

BRITISH STANDARDS INSTITUTION

**SPECIFICATION FOR
UNPLASTICIZED PVC PIPE
FOR INDUSTRIAL USES**

BS 3506 : 1969

**Incorporating amendments issued September 1973 (AMD 1152)
and July 1975 (AMD 1777)**

BRITISH STANDARDS INSTITUTION

Incorporated by Royal Charter

2 PARK STREET, LONDON, W1A 2BS

Telex: 266934

Telephone: 01-629 9000

BS 3506 : 1969

THIS BRITISH STANDARD, having been approved by the Plastics Industry Standards Committee, was published under the authority of the Executive Board on 30th September, 1969.

First published, June, 1962.

First revision, September, 1969.

SBN: 580 05840 9

The Institution desires to call attention to the fact that this British Standard does not purport to include all the necessary provisions of a contract.

In order to keep abreast of progress in the industries concerned, British Standards are subject to periodical review. Suggestions for improvements will be recorded and in due course brought to the notice of the committees charged with the revision of the standards to which they refer.

A complete list of British Standards, numbering over 9,000, fully indexed and with a note of the contents of each, will be found in the BSI Catalogue which may be purchased from BSI Sales Department. The Catalogue may be consulted in many public libraries and similar institutions.

This standard makes reference to the following British Standards:

- BS 509. Acetone.
- BS 2782. Methods of testing plastics.
- BS 3505. Unplasticized PVC pipe for cold water services.
- BS 3867. Dimensions of pipes of plastics materials (outside diameters and pressure ratings).
- BS 4159. Colour marking of plastics pipes to indicate pressure ratings.
- CP . . . * Plastics pipework (thermoplastic material).

British Standards are revised, when necessary, by the issue either of amendment slips or of revised editions. It is important that users of British Standards should ascertain that they are in possession of the latest amendments or editions.

* In course of preparation.

The following BSI references relate to the work on this standard:
Committee references PLC/9, PLC/9/3
Draft for comment 68/8559

CONTENTS

	Page
Co-operating organizations	4
Foreword	5

SPECIFICATION

1. Scope	5
2. Material	6
3. Designation of dimensional characteristics	6
4. Classification of pipes	6
5. Dimensions	6
6. Method of measuring dimensional characteristics	10
7. Lengths	10
8. Physical characteristics	11
9. Mechanical characteristics	11
10. Sampling	12
11. Marking	12
12. Stocking and transport	12

APPENDICES

A. Heat reversion test	13
B. Test for resistance to acetone	14
C. Test for resistance to sulphuric acid	14
D. Tensile test	15
E. Test for impact strength at 20 °C	15
F. Short term hydrostatic test	17
G. Long term hydrostatic test	18
H. Equivalent values of maximum sustained working pressures, tensile strength and stresses in bars, technical metric and imperial units	20

TABLES

1. Pipe dimensions	8
2. Maximum sustained working pressures for Class 6 and Class 7 pipes	10
3. Mass of striker	16

FIGURE

1. Impact testing machine	21
---------------------------	----

BS 3506 : 1969

CO-OPERATING ORGANIZATIONS

The Plastics Industry Standards Committee, under whose supervision this British Standard was prepared, consists of representatives from the following Government departments and scientific and industrial organizations:

Board of Trade

British Electrical and Allied Manufacturers' Association

*British Plastics Federation

Electrical Research Association

*Engineering Equipment Users' Association

*Ministry of Defence, Army Department

*Ministry of Defence, Navy Department

*Ministry of Public Building and Works, Building Research Station

Ministry of Technology

*Oil Companies Materials Association

Plastics Institute

Post Office

*Royal Institute of British Architects

Royal Institute of Public Health and Hygiene

Rubber and Plastics Research Association of Great Britain

Society of Motor Manufacturers and Traders Ltd.

Surface Coating Synthetic Resin Manufacturers' Association

The Government departments and scientific and industrial organizations marked with an asterisk in the above list, together with the following, were directly represented on the committee entrusted with the preparation of this British Standard:

Agrément Board

Associated Master Plumbers and Domestic Engineers

Association of Industrialized Building Component Manufacturers Ltd.

Association of Public Health Inspectors

British Chemical Plant Manufacturers' Association

British Mechanical Rubber Manufacturers' Association

British Rubber Manufacturers' Association Ltd.

British Waterworks Association

Chemical Industries Association

Copper Tube Fittings Manufacturers' Association

Dairy Engineers' Association

Department of Health and Social Security

Food Manufacturers' Federation (Inc.)

Gas Council

Gas List Tube Association

Greater London Council

Institute of Brewing

Institute of Plumbing

Institution of Civil Engineers

Institution of Municipal Engineers

Institution of Public Health Engineers

Institution of Water Engineers

Lloyd's Register of Shipping

Milk Distributive Council

Milk Marketing Board

Ministry of Agriculture, Fisheries and Food

Ministry of Housing and Local Government

Ministry of Public Building and Works

National Coal Board

National Federation of Plumbers and Domestic Heating Engineers

(Employers)

National Institute for Research in Dairying

Plastic Pipe Manufacturers Society

Royal Society for the Promotion of Health

Society of Builders Merchants

United Kingdom Atomic Energy Authority

Water Companies' Association

Water Research Association

BRITISH STANDARD SPECIFICATION FOR UNPLASTICIZED PVC PIPE FOR INDUSTRIAL PURPOSES

FOREWORD

This British Standard has been prepared under the authority of the Plastics Industry Standards Committee. It is based on a draft submitted by the British Plastics Federation. In the present issue, Table 1 specifies dimensions that are in accordance with BS 3867*. These dimensions and also the other requirements of the standard are the same, as far as possible, as those specified in BS 3505†.

Classes B, C, D and E are identical to those specified in BS 3505† whilst Classes O, 6 and 7 are provided to give dimensions suitable for non-pressure duct applications and for extra thick pipes for hazardous duty and screw threading.

To avoid possible confusion during the period of transition to full metric thinking, it has been decided that the sizes, although dimensioned in metric units, should be designated using nominal size description corresponding to the established values in inches.

Maximum sustained working pressures, tensile strength and hydraulic stress levels are specified in bars‡ but Appendix H is included giving equivalent values in technical metric and imperial units.

Attention is drawn to CP . . . § which is being prepared to assist users in assessing the suitability of plastics pipes for particular purposes and to ensure their proper application.

Pipes complying with this standard should not be used to convey potable water, for which purpose pipes complying with BS 3505† are suitable.

SPECIFICATION

1. SCOPE

1.1 This British Standard applies to unplasticized polyvinyl chloride pipe up to and including 24 in nominal size, for industrial purposes. One series of thinner wall pipes and one of thicker wall pipes are included in addition to those covered by BS 3505†.

*As altered
Sept. 1973*

1.2 Pipe complying with BS 3505† is deemed to comply with the requirements for corresponding classes in this standard.

* BS 3867, 'Dimensions of pipes of plastics materials (outside diameters and pressure ratings)'.

† BS 3505, 'Unplasticized PVC pipe for cold water services'.

‡ 1 bar = 10^5 N/m².

§ CP, 'Plastics pipework (thermoplastic material)'.

Part 1, 'General principles and choice of material'.

Part 2, 'Unplasticized PVC'. (In course of preparation.)

BS 3506 : 1969

2. MATERIAL

2.1 The material from which the pipe is produced shall consist substantially of polyvinyl chloride, to which may be added only those additives that are needed to facilitate the manufacture of the polymer, and the production of sound, durable pipe of good surface finish, mechanical strength and opacity. None of these additives shall be used separately or together in quantities sufficient to impair the fabrication or welding properties of the pipe, or to impair its chemical and physical properties (in particular long-term mechanical strength and impact strength) as defined in this standard.

2.2 The addition of the manufacturer's own rework material produced during the manufacture and works testing of pipe complying with this standard, is permissible. No other rework material shall be used.

2.3 When tested by Method 102 J of BS 2782*, the deformation temperature of the material under load shall not be lower than 75 °C.

3. DESIGNATION OF DIMENSIONAL CHARACTERISTICS

Pipe dimensions shall be designated by the nominal size. Outside diameters shall conform to Table 1 of BS 3867†.

4. CLASSIFICATION OF PIPES

Pipes are classified as follows:

Class O	(non pressure)
Class B	6.0 bar‡ (60 m head of water)
Class C	9.0 bar (90 m head of water)
Class D	12.0 bar (120 m head of water)
Class E	15.0 bar (150 m head of water)
Class 6 } Class 7 }	see Table 2 for maximum sustained working pressures.

NOTE 1. Class O pipe should not be used buried below ground.

NOTE 2. The maximum sustained working pressures to which reference is made above are based on water at a temperature of 20 °C. When used for materials other than water reference should be made to CP , 'Plastics pipework (thermoplastic material)', Part 2, 'Unplasticized PVC' (in course of preparation).

5. DIMENSIONS

As altered July 1975 Pipes shall conform to the outside diameters and wall thicknesses specified in Table 1. Determine the wall thickness at not less than six points around the

* BS 2782, 'Methods of testing plastics'.

† BS 3867, 'Dimensions of pipes of plastics materials (outside diameters and pressure ratings)'.

‡ 1 bar = 10⁵ N/m².

circumference of the pipe ensuring that the least and greatest values of wall thickness are included. Calculate the mean of these determinations which shall not exceed the value given in the appropriate column of Table 1 headed averaged value, max.

NOTE. The maximum averaged wall thickness is based on a tolerance of $+0.1e + 0.2$ mm (with a minimum value of 0.3 mm). The maximum individual value is based on a tolerance of $+0.15e$ or $+0.1e + 0.2$ mm, whichever is the greater, where e is the minimum wall thickness.

TABLE 1. PIPE DIMENSIONS

As altered
July 1975

Nominal size	Mean outside diameter		Wall thickness																	
			Class O (non pressure)			Class B 6.0 bar *			Class C 9.0 bar *			Class D 12.0 bar *								
			min.	max.	averaged value	min.	max.	individual value	min.	max.	averaged value	min.	max.	individual value	min.	max.	averaged value	min.	max.	individual value
3/8	17.0	17.3	mm	mm	mm	mm	mm	mm	mm	mm	mm	mm	mm	mm	mm	mm	mm	mm	mm	mm
1/2	21.2	21.5	—	—	—	—	—	—	—	—	—	—	—	—	—	—	—	—	—	—
3/4	26.6	26.9	—	—	—	—	—	—	—	—	—	—	—	—	—	—	—	—	—	—
1	33.4	33.7	—	—	—	—	—	—	—	—	—	—	—	—	—	—	—	—	—	—
1 1/4	42.1	42.4	—	—	—	—	—	—	—	—	—	—	—	—	—	—	—	—	—	—
1 1/2	48.1	48.4	—	—	—	—	—	—	—	—	—	—	—	—	—	—	—	—	—	—
2	60.2	60.5	2.2	2.2	2.2	2.2	2.2	2.2	2.2	2.2	2.2	2.2	2.2	2.2	2.2	2.2	2.2	2.2	2.2	2.2
2 1/2	75.0	75.3	2.2	2.2	2.2	2.2	2.2	2.2	2.2	2.2	2.2	2.2	2.2	2.2	2.2	2.2	2.2	2.2	2.2	2.2
3	88.7	89.1	2.2	2.2	2.2	2.2	2.2	2.2	2.2	2.2	2.2	2.2	2.2	2.2	2.2	2.2	2.2	2.2	2.2	2.2
4	114.1	114.5	2.8	2.8	2.8	2.8	2.8	2.8	2.8	2.8	2.8	2.8	2.8	2.8	2.8	2.8	2.8	2.8	2.8	2.8
5	140.0	140.4	3.1	3.1	3.1	3.1	3.1	3.1	3.1	3.1	3.1	3.1	3.1	3.1	3.1	3.1	3.1	3.1	3.1	3.1
6	168.0	168.5	3.7	3.7	3.7	3.7	3.7	3.7	3.7	3.7	3.7	3.7	3.7	3.7	3.7	3.7	3.7	3.7	3.7	3.7
7	193.5	194.0	3.7	3.7	3.7	3.7	3.7	3.7	3.7	3.7	3.7	3.7	3.7	3.7	3.7	3.7	3.7	3.7	3.7	3.7
8	218.8	219.4	3.7	3.7	3.7	3.7	3.7	3.7	3.7	3.7	3.7	3.7	3.7	3.7	3.7	3.7	3.7	3.7	3.7	3.7
9	244.1	244.8	3.7	3.7	3.7	3.7	3.7	3.7	3.7	3.7	3.7	3.7	3.7	3.7	3.7	3.7	3.7	3.7	3.7	3.7
10	272.6	273.4	3.7	3.7	3.7	3.7	3.7	3.7	3.7	3.7	3.7	3.7	3.7	3.7	3.7	3.7	3.7	3.7	3.7	3.7
12	323.4	324.3	3.7	3.7	3.7	3.7	3.7	3.7	3.7	3.7	3.7	3.7	3.7	3.7	3.7	3.7	3.7	3.7	3.7	3.7
14	355.0	356.0	4.2	4.2	4.2	4.2	4.2	4.2	4.2	4.2	4.2	4.2	4.2	4.2	4.2	4.2	4.2	4.2	4.2	4.2
16	405.9	406.9	4.8	4.8	4.8	4.8	4.8	4.8	4.8	4.8	4.8	4.8	4.8	4.8	4.8	4.8	4.8	4.8	4.8	4.8
18	456.7	457.7	5.3	5.3	5.3	5.3	5.3	5.3	5.3	5.3	5.3	5.3	5.3	5.3	5.3	5.3	5.3	5.3	5.3	5.3
20	507.5	508.5	5.9	5.9	5.9	5.9	5.9	5.9	5.9	5.9	5.9	5.9	5.9	5.9	5.9	5.9	5.9	5.9	5.9	5.9
22	558.3	559.3	6.4	6.5	6.5	6.5	6.5	6.5	6.5	6.5	6.5	6.5	6.5	6.5	6.5	6.5	6.5	6.5	6.5	6.5
24	609.1	610.1	7.0	7.1	7.1	7.1	7.1	7.1	7.1	7.1	7.1	7.1	7.1	7.1	7.1	7.1	7.1	7.1	7.1	7.1

* 1 bar = 10⁵ N/m² † Pipes to these nominal sizes are not normally available from stock.
 NOTE 1. The pressures given at the top of the columns for Classes B, C and D are the maximum sustained working pressures for which the pipes are suitable and are based on water at a temperature of 20°C.
 NOTE 2. Equivalent values of working pressures in other units are given in Appendix H.

TABLE 1. PIPE DIMENSIONS (continued)

As altered
July, 1975

Nominal size	Mean outside diameter		Wall thickness											
			Class E 15.0 bar*				Class 6 (see Table 2)				Class 7 (see Table 2)			
			averaged value		individual value		averaged value		individual value		averaged value		individual value	
			max.	min.	max.	min.	max.	min.	max.	min.	max.	min.	max.	
1/4	mm	mm	mm	mm	mm	mm	mm	mm	mm	mm	mm	mm	mm	mm
3/8	13.6	13.9	1.7	1.3	2.7	2.2	2.7	2.2	2.2	2.7	2.2	2.7	2.2	2.7
1/2	17.0	17.3	1.9	1.5	3.2	2.7	3.2	2.7	2.7	3.2	2.7	3.2	2.7	3.2
3/4	21.2	21.5	2.1	1.7	3.7	3.1	3.7	3.1	3.1	3.7	3.1	3.7	3.1	3.7
1	26.6	26.9	2.5	1.9	4.5	3.9	4.5	3.9	3.9	4.5	3.9	4.5	3.9	4.5
1 1/4	33.4	33.7	2.7	2.2	5.5	4.8	5.5	4.8	4.0	5.2	4.5	5.2	4.5	5.2
1 1/2	42.1	42.4	3.2	2.7	6.6	5.7	6.6	5.7	4.2	5.5	4.8	5.5	4.8	5.5
2	48.1	48.4	3.7	3.1	8.4	7.3	8.4	7.3	4.3	5.9	5.1	5.9	5.1	5.9
2 1/2†	60.2	60.5	4.5	3.9	10.4	9.0	10.4	9.0	—	6.3	5.5	6.3	5.5	6.3
3	75.0	75.3	5.5	4.8	—	—	—	—	—	—	—	—	—	—
4	88.7	89.1	6.5	5.7	—	—	—	—	—	—	—	—	—	—
5†	114.1	114.5	8.3	7.3	—	—	—	—	—	—	—	—	—	—
6	140.0	140.4	10.1	9.0	—	—	—	—	—	—	—	—	—	—
7†	168.0	168.5	12.1	10.8	—	—	—	—	—	—	—	—	—	—
8	193.5	194.0	13.9	12.4	—	—	—	—	—	—	—	—	—	—
9	218.8	219.4	14.1	12.6	—	—	—	—	—	—	—	—	—	—
10	244.1	244.8	15.8	14.1	—	—	—	—	—	—	—	—	—	—
12	272.6	273.4	17.5	15.7	—	—	—	—	—	—	—	—	—	—
14	323.4	324.3	20.8	18.7	—	—	—	—	—	—	—	—	—	—
16	355.0	356.0	22.8	20.5	—	—	—	—	—	—	—	—	—	—
18	405.9	406.9	26.0	23.4	—	—	—	—	—	—	—	—	—	—
20	456.7	457.7	—	—	—	—	—	—	—	—	—	—	—	—
22	507.5	508.5	—	—	—	—	—	—	—	—	—	—	—	—
24	558.3	559.3	—	—	—	—	—	—	—	—	—	—	—	—
24	609.1	610.1	—	—	—	—	—	—	—	—	—	—	—	—

* 1 bar = 10⁵ N/m²
 † Pipes to these nominal sizes are not normally available from stock.
 NOTE 1. The pressure given at the top of the column for Class E is the maximum sustained working pressure for which the pipes are suitable and is based on water at a temperature of 20 °C.
 NOTE 2. Class 7 pipes are suitable for screw threading for pressures not exceeding Class C rating.
 NOTE 3. Classes 6 and 7 are equivalent to American Schedules 40 and 80 respectively. Larger diameters in these schedule sizes are not required since they are close to (in some cases less than) the wall thickness selected for Class E pressure rating.
 NOTE 4. Equivalent values of working pressures in other units are given in Appendix H.

BS 3506 : 1969

TABLE 2. MAXIMUM SUSTAINED WORKING PRESSURES FOR CLASS 6 AND CLASS 7 PIPES*As altered
Sept. 1973*

Nominal size	Class 6		Class 7	
	bar*	m head of water	bar*	m head of water
¼	36	360	52	520
⅜	30	300	44	440
½	28	280	40	400
¾	22	220	32	320
1	24	240	32	320
1¼	20	200	28	280
1½	18	180	25	250
2	—	—	22	220

*1 bar = 10⁵ N/m²

NOTE 1. The pressures given are the maximum sustained working pressures for which the pipes are suitable and are calculated on water at a temperature of 20°C.

NOTE 2. Equivalent values of working pressures in other units are given in Appendix H.

6. METHOD OF MEASURING DIMENSIONAL CHARACTERISTICS

6.1 Outside diameters. Outside diameters shall comply with the requirements of Table 1. An out of roundness tolerance of $\pm 0.5\%$ calculated on the mean of the values stated in columns 2 and 3 of Table 1 is permitted for Classes C, D, E, 6 and 7.

NOTE. This extra ovality tolerance is not necessary for thinner walled pipe which may easily be re-rounded.

6.2 Tolerance on length. The effective length as laid shall not be less than the appropriate length specified in 7.1, or as ordered in accordance with 7.2.

7. LENGTHS

7.1 Pipes shall be supplied in straight lengths, normally of 3 m (10 ft), 6 m (20 ft) and 9 m (30 ft).

7.2 Other lengths may be supplied, if required by the purchaser and by agreement with the manufacturer.

8. PHYSICAL CHARACTERISTICS

8.1 Appearance. The pipe shall be reasonably round (see also 6.1 for Classes C, D, E, 6 and 7). The internal and external surfaces of the pipe shall be smooth, clean and reasonably free from grooving and other defects that would impair its performance in service. The ends shall be cleanly cut and square with the axis of the pipe.

8.2 Heat reversion test. When tested by the method described in Appendix A, at no point round the pipe shall the length change by more than 5.0%. After testing, the pipe shall show no faults, e.g. cracks, cavities or blisters.

8.3 Resistance to acetone. When tested by the method described in Appendix B, the sample shall show no delamination or disintegration. Flattening and/or swelling of the pipe shall not be deemed to constitute failure.

8.4 Resistance to sulphuric acid. When tested by the method described in Appendix C, the mass of the specimen shall not increase by more than 0.32 g nor decrease by more than 0.013 g. The effect of the acid on the surface appearance of the specimen (roughening, bleaching or blackening) shall be ignored.

*As altered
Sept. 1973*

9. MECHANICAL CHARACTERISTICS

9.1 Tensile properties (for Class 'O' pipes only). When tested by the method described in Appendix D, the tensile strength of the pipe at maximum load shall be not less than 441 bar* (6400 lbf/in²) and the elongation at break shall be not less than 80%.

9.2 Impact strength at 20 °C. The pipe shall pass the test described in Appendix E.

9.3 Short term hydrostatic test (not for Class 'O' pipes). When tested by the method described in Appendix H, the pipe shall withstand the appropriate minimum internal hydrostatic pressure for at least 1 hour without failure as shown:

*As altered
Sept. 1973*

BS 3506 : 1969

As altered
Sept. 1973

Class and size of pipe	Minimum 1 hour internal hydrostatic pressure	
	bar	(lbf/in ²)
B all sizes	21.6	(310)
C all sizes	32.4	(470)
D all sizes	43.2	(620)
E all sizes	54.0	(780)
6 — ¼	129.6	(1880)
6 — ⅜	108.0	(1560)
6 — ½	100.8	(1460)
6 — ¾	79.2	(1150)
6 — 1	86.4	(1253)
6 — 1¼	72.0	(1040)
6 — 1½	64.8	(940)
7 — ¼	187.2	(2710)
7 — ⅜	158.4	(2290)
7 — ½	144.0	(2090)
7 — ¾	115.2	(1670)
7 — 1	115.2	(1670)
7 — 1¼	100.8	(1460)
7 — 1½	90.0	(1300)
7 — 2	79.2	(1150)

9.4 Long term hydrostatic test (not for Class 'O' pipes).

9.4.1 When tested by the method described in Appendix G, the extrapolated 1 h and 50 year circumferential stress levels shall be not less than the appropriate values as shown:

Nominal size of pipe	Minimum 1 hour stress		Minimum 50 year stress	
	bar	(lbf/in ²)	bar	(lbf/in ²)
¾ and below	353	(5124)	206	(2988)
1 to 7	396	(5700)	230	(3340)
8 and above	443	(6430)	260	(3770)

9.4.2 A specimen sample that passes the 1 h to 10 h test in the long term hydrostatic test shall be deemed to have satisfied the requirements of the short term hydrostatic test (see 9.3), provided it also passes the 1 h stress requirement specified in 9.3.

10. SAMPLING

10.1 For quality control during manufacture, sampling procedures shall be as described in Appendices A to G as appropriate. The manufacturer shall ensure that all unsatisfactory pipe is identified and rejected.

10.2 The sampling clauses of this standard have been devised to suit the manufacturing process of unplasticized PVC pipe; consequently sampling by the purchaser from stock, of which relationship to the manufacturing process is unknown, shall be agreed with the manufacturer.

11. MARKING

11.1 All pipes shall be indelibly marked at intervals of not greater than 3 m. The marking shall show in the order stated: the manufacturer's identification, the number of this British Standard, i.e. BS 3506, the nominal size as shown in Table 1 and the class.

Adhesive labels alone shall not suffice for this marking.

11.2 The marking shall be imprinted longitudinally in the following colours, in accordance with BS 4159*:

Class 'O', white	Class D, green
Class B, red	Class E, brown
Class C, blue	Class 6, brown
	Class 7, brown

NOTE. It is strongly recommended that in view of the nature of this standard manufacturers and purchasers should make use of the certification scheme whereby the product may bear the registered certification mark of BSI. For further information, see the back cover of this standard.

12. STOCKING AND TRANSPORT

The ends of the pipe shall be suitably protected from damage.

APPENDIX A

HEAT REVERSION TEST

A.1 This test may be carried out either in an air oven or alternatively in a bath of polyethylene glycol, glycerol or a mineral oil free from aromatic hydrocarbons. *As altered Sept. 1973*

A.2 Form of test specimen. The test specimen shall consist of a length of pipe approximately 300 mm long. Two circumferential marks shall be scribed on the test specimen 100 mm apart and in such a way that one of these marks is approximately 15 mm from one end of the specimen.

† BS 4159, 'Colour marking of plastics pipes to indicate pressure ratings'.

BS 3506 : 1969

A.3 Immersion method

A.3.1 Apparatus. A thermostatically-controlled bath in which the heat transfer medium is polyethylene glycol, glycerol or mineral oil free from aromatic hydrocarbons. The bath is stirred continuously and maintained automatically at a temperature of 150 ± 2 °C.

A.3.2 Procedure. The test specimen shall be suspended in the heat transfer medium by the end furthest from the scribed marks in such a way that both scribed marks are completely immersed. Care shall be taken to ensure that the specimen does not contact the sides or bottom of the bath.

The test specimen shall be immersed in the bath for a time determined as follows:

- (1) For pipe of wall thickness not greater than 8.6 mm – 15 minutes.
- (2) For pipe of wall thickness greater than 8.6 mm but not greater than 14.1 mm – 30 minutes.
- (3) For pipe of wall thickness greater than 14.1 mm – 60 minutes.

After the specified immersion period, the specimen shall be removed from the bath, laid on its side and allowed to cool to room temperature. The distance between the two scribed marks shall be measured along the surface of the pipe and the percentage change in length calculated.

A.4 Oven method

A.4.1 Apparatus. An electrically-heated air oven with circulating fan, the whole interior of which is maintained automatically at a temperature of 150 ± 2 °C.

A.4.2 Procedure. The specimens shall be placed in the oven and the time measured from the moment at which the oven regains a temperature of 150 °C.

The test specimens shall be kept in the oven for a time determined as follows:

- (1) For pipe of wall thickness not greater than 8.6 mm – 60 minutes.
- (2) For pipe of wall thickness greater than 8.6 mm but not greater than 14.1 mm – 120 minutes.
- (3) For pipe of wall thickness greater than 14.1 mm – 240 minutes.

After the specified heating period, the specimen shall be removed from the oven, laid on its side and allowed to cool to room temperature. The distance between the two scribed marks shall be measured along the surface of the pipe and the percentage change in length calculated.

APPENDIX B

TEST FOR RESISTANCE TO ACETONE

B.1 Procedure. A short length of pipe shall be immersed vertically to a depth of at least 25 mm (1 in) in acetone complying with BS 509* at room temperature.

The effect of the acetone on the pipe surfaces shall be noted after 2 h.

B.2 Sampling and assessment of results. A specimen shall be taken from each machine at least once every 8 h running and shall meet the requirements given in 8.3.

APPENDIX C

TEST FOR RESISTANCE TO SULPHURIC ACID

NOTE. This is a type test for material and should be carried out for each formulation used and when a change is made in composition or method of manufacture of the pipe.

C.1 Form of test specimen. The test specimen shall be cut from the pipe and shall have a total surface area of $45 \pm 3 \text{ cm}^2$ ($7.0 \pm 0.5 \text{ in}^2$).

C.2 Procedure. The test specimen shall be cleaned, wiped dry and weighed, then totally immersed in $93 \pm 0.5 \%$ (m/m) sulphuric acid for 14 days at $55 \pm 2^\circ\text{C}$. Care shall be taken to avoid gradual concentration of the acid during the test due to evaporation losses, etc. After the specified time the specimen shall be removed, washed in running water for 5 min, wiped dry with a clean cloth and reweighed immediately.

C.3 Sampling and assessment of results. Three specimens shall be taken from each nominal size of pipe. The average change in mass shall not exceed the value given in 8.4.

APPENDIX D

TENSILE TEST

D.1 Procedure. The pipe shall be tested by Methods 301F and 301G of BS 2782* subject to the following provisions:

D.1.1 The specimen shall be cut longitudinally from a length of pipe by either:

(1) heating and flattening it at a temperature of 125°C to 130°C , then machining it or routing it out from the tube wall, in which case the edges of the specimen shall be polished to remove notches, or

(2) punching it from a section of pipe heated to a temperature of 125°C to 130°C and subsequently flattening it. The cutting edges of the punch shall have the profile shown in Fig. 301.9 of BS 2782* and they shall be free from notches.

D.1.2 The elongation at break and tensile strength shall be measured as described in Methods 301F and 301G respectively, but at a straining rate of 3 mm/min.

* BS 509, 'Acetone'.

* BS 2782, 'Methods of testing plastics'.

BS 3506 : 1969

D.2 Sampling and assessment of results. A sample shall be taken from each machine at least once in every 8 h running, and shall meet the requirements specified in 9.1.

APPENDIX E

TEST FOR IMPACT STRENGTH AT 20 °C

E.1 Form of test specimen. Each specimen shall be a complete section of pipe, of a length equal to twice the nominal size or 150 mm (6 in), whichever is the greater, subject to a maximum length of 300 mm (12 in.) The ends of the specimen shall be cut clean and square to the axis of the pipe. Each specimen shall be conditioned for at least 30 min in a water bath maintained at a temperature of 20 ± 1 °C and individual specimens shall be tested within 5 min of removal from the bath.

E.2 Apparatus. A falling weight machine (a suitable form of which is shown in Fig. 1) shall be used and shall consist essentially of the following:

- (1) A main frame which can be rigidly fixed in a true vertical position.
- (2) Guide rails carried from the inside of the main frame, on side bearings which can be adjusted to keep them parallel and vertical.
- (3) A weighted striker which can fall freely within the guide rails and which is equipped with a hardened hemispherical striking surface 25 mm (1 in) diameter. The striking surface shall be free from flats and other imperfections.
- (4) An appropriate set of weights which can be firmly attached to the striker to enable the combined mass of striker and weight to be adjusted to the values given in Table 3.
- (5) A specimen support comprising a 120° vee block at least 230 mm (6 in) in length which is positioned below the guide rails so that the tip of the striker is not more than 2.5 mm (0.1 in) from the axis of the vee block.
- (6) A release mechanism such that the striker can fall through a height of 2.0 ± 0.01 m (78.6 ± 0.4 in) on to the top surface of the pipe specimen.
- (7) Means for maintaining a constant height of fall by vertical movement of either the vee block, the release mechanism or the main frame, in order to accommodate different diameters of pipe.

E.3 Procedure. The total mass of the striker shall be adjusted to the value appropriate to the diameter of the pipe under test as shown in Table 3, except that the total mass shall be halved for Classes 6 and 7 pipes. The striker shall then be allowed to fall freely through a height of 2 m (78.6 in) on to the pipe specimen which is centrally mounted on the vee block support.

TABLE 3. MASS OF STRIKER

Nominal size of pipe	Total mass of striker	Nominal size of pipe	Total mass of striker
	kg		kg
$\frac{1}{4}$	0.25	4	2.75
$\frac{3}{8}$	0.5	5	3.25
$\frac{1}{2}$	0.75	6	3.75
$\frac{3}{4}$	1.0	7	4.0
1	1.25	8	5.0
$1\frac{1}{4}$	1.375	9	5.75
$1\frac{1}{2}$	1.5	10	6.25
2	1.75	12	7.50
$2\frac{1}{2}$	2.0	above 12	7.50
3	2.25		

Specimens from $\frac{1}{4}$ in to $1\frac{1}{2}$ in (inclusive) nominal size shall be subjected to a single blow only. For pipes of 2 in nominal size and above, the following procedure shall be adopted.

Each specimen shall be marked with a longitudinal zero line positioned at random and from this line, further parallel lines shall be marked equidistantly at intervals of not less than 50 mm (2 in). The pipe shall be placed on the vee block so that one of the marked lines is uppermost. The weighted striker shall then be allowed to fall freely on to the marked line on the pipe as described above.

If the specimen does not fail as a result of cracking or splitting, the specimen shall be rotated until the next marked line is uppermost in the vee block, and a second blow made by the striker. The process shall then be repeated until all the marked lines have been tested, or until a failure is recorded. (This procedure of impact testing a specimen more than once is known as 'round the clock' testing.)

E.4 Number of test specimens. Initially sufficient specimens shall be taken at random from each machine so that at least one is taken per shift and at least 14 strikes made per extrusion run. If no specimen fails (defined as fracturing or cracking through its complete wall thickness), no further test specimens need be taken. If, during the test 4 specimens fail, the test may be discontinued. If, of the initial 14 strikes, 1, 2 or 3 specimens fail, further specimens shall be taken at random and tested to ensure a total of at least 42 strikes.

If, during the testing of the further samples the total number of failures exceeds 5, the test may be discontinued.

BS 3506 : 1969

E.5 Assessment of results. If the first 14 strikes are made without failures, the pipes shall be deemed to have passed the test.

If the first 14 strikes are made with 4 or more failures occurring, the pipes shall be deemed not to have passed the test.

If, because of 1, 2 or 3 failures, it is found necessary to increase the total number of strikes to 42, the pipes shall be deemed not to have passed the test if out of 42 strikes 5 or more failures occur.

APPENDIX F

SHORT TERM HYDROSTATIC TEST

(Not for Class 'O' pipes)

F.1 Form of test specimen. Each test specimen shall be a piece of pipe, the free length of which between the end fittings shall be equal to 10 times the outside diameter of the pipe subject to a minimum of 250 mm (10 in) and a maximum of 750 mm (30 in).

F.2 Apparatus. The apparatus consists of a thermostatically controlled bath maintained at $20 \pm 1^\circ\text{C}$ and equipment that permits the application of a controlled internal hydrostatic pressure to the specimens to an accuracy of $\pm 2\%$.

*As altered
Sept. 1973*

F.3 Procedure. The specimen shall be connected to the apparatus provided. The appropriate internal hydrostatic pressure specified in Clause 9.3 shall then be applied and achieved within 30 to 40 seconds of first admitting pressure, and shall be maintained with an accuracy of $\pm 2\%$ throughout the test. The specimen shall be maintained at $20 \pm 1^\circ\text{C}$ throughout the test.

APPENDIX G

LONG TERM HYDROSTATIC TEST

(Not for Class 'O' pipes)

G.1 Form of test specimen. The test sample shall be two pieces of pipe cut adjacent to each other. Each piece of pipe shall have a free length between the end fittings equal to 10 times the outside diameter of the pipe, subject to a minimum of 250 mm (10 in) and a maximum of 750 mm (30 in).

G.2 Apparatus. The apparatus consists of a temperature bath controlled at $20 \pm 1^\circ\text{C}$ and equipment that permits the application of controlled internal hydrostatic pressure to pipe specimens to an accuracy of $\pm 2\%$.

G.3 Procedure. The minimum wall thickness and the mean outside diameter of each specimen shall be determined and the internal pressure applied shall be calculated from the formula:

$$P = \frac{2 \delta t}{D - t}$$

where P = pressure to be applied, in bars*,
 δ = circumferential stress, in bars,
 t = minimum wall thickness, in millimetres
and D = mean outside diameter, in millimetres.

The specimen shall be connected to the apparatus. The calculated internal hydrostatic pressure shall then be applied and achieved within 30 s to 40 s of first admitting pressure, and shall be maintained with an accuracy of $\pm 2\%$ throughout the test. The specimen shall be maintained at $20 \pm 1^\circ\text{C}$ and the mean temperature throughout the test shall be $20 \pm 0^\circ\text{C}$.

For each test specimen stresses shall be so chosen that the first piece of pipe shall be expected to burst within a period of 1 h to 10 h and the second piece of pipe shall be expected to burst within a period of 100 h to 1000 h. Both pieces of pipe shall be tested to failure.

G.4 Sampling and assessment of results. One test unit shall be set up per machine making pipe complying with this standard. The test sample shall be two pieces of pipe as defined in G.1.

For the first piece of pipe the stress shall be chosen so that failure may be expected in the period 1 h to 10 h, and for the second piece of pipe (tested immediately after the first) the stress shall be chosen so that failure may be expected in the period 100 h to 1000 h. This test procedure shall be repeated immediately and continuously at each test point.

For each size and class of pipe, the results for test specimens (i.e. 2 pieces of pipe) shall be entered on a log (stress) versus log (time) graph. The results accumulated shall be subjected to regression analysis periodically so as to obtain representative extrapolated 1 h and 50 years stress levels. These extrapolated stress levels shall meet the requirements specified in 9.4.

NOTE. The extrapolated stress levels are obtained by substituting the appropriate values for log (time), in the linear regression equation for log (time) on a log (stress). The regression equation is calculated by the method of least squares.

BS 3506 : 1969

APPENDIX H

EQUIVALENT VALUES OF MAXIMUM SUSTAINED WORKING PRESSURES, TENSILE STRENGTH AND STRESSES IN BARS, TECHNICAL METRIC AND IMPERIAL UNITS

H.1 Maximum sustained working pressures

bar*	kgf/cm ²	lbf/in ²	head of water	
			m	ft
6	6.12	86.7	60	200
9	9.18	130	90	300
12	12.25	173	120	400
15	15.30	217	150	500
18	18.35	260	180	600
20	20.39	289	200	667
24	24.47	347	240	800
26	26.51	375	260	867
32	32.63	462	320	1067
36	36.71	520	360	1200
40	40.79	578	400	1333
45	45.89	650	450	1500
60	61.18	867	600	2000

NOTE. The above conversions from pressures in bars to other units are approximate only; more accurate conversions should be based on the factors given in BS 350, 'Conversion factors and tables', Part 1, 'Basis of tables. Conversion factors'.

H.2 Tensile strength

bar*	kgf/cm ²	lbf/in ²
441	450	6400

H.3 Stresses

bar*	kgf/cm ²	lbf/in ²
230	235	3340
260	265	3770
392	400	5700
427	435	6190

* 1 bar = 10⁵ N/m².

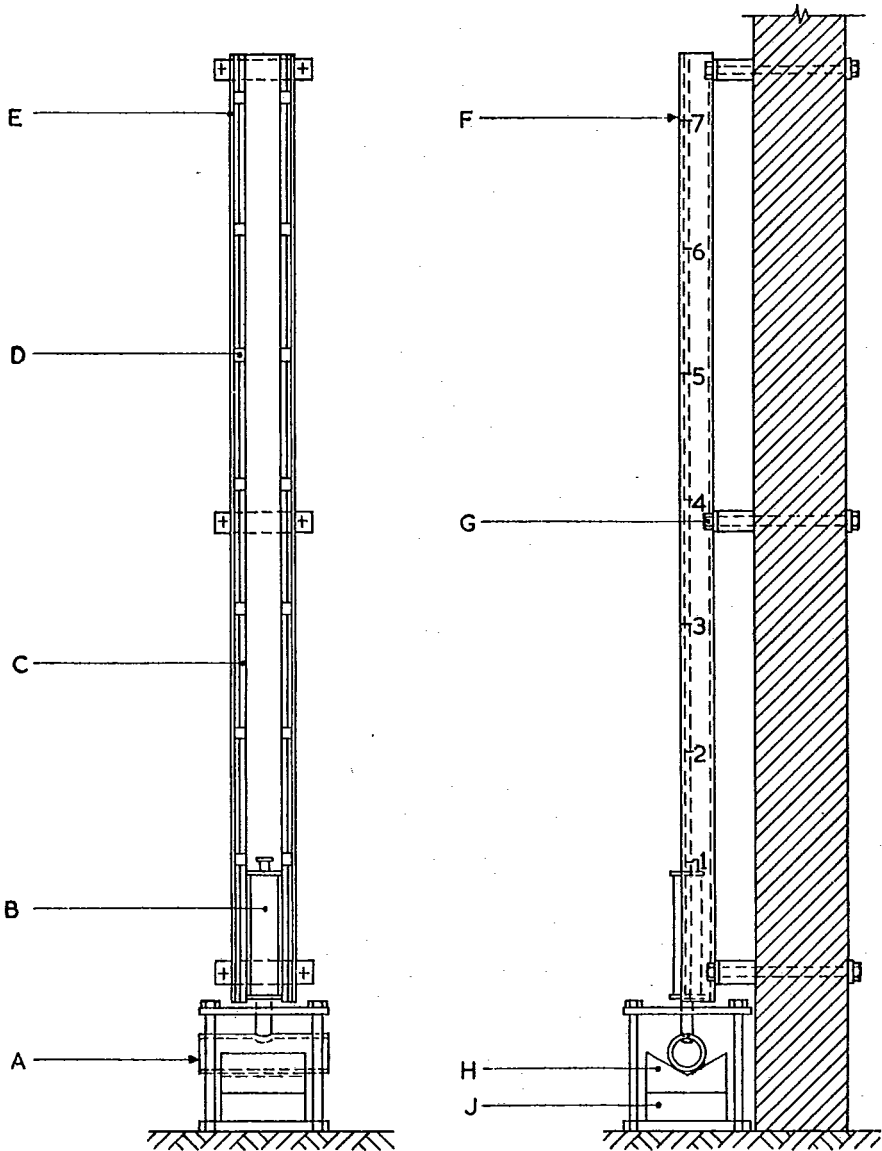

A—Test specimen of pipe
 B—Striker weight
 C—Guide rod
 D—Bearing

E—Support channel
 F—Graduated scale
 G—Clamp bolt and plates
 H—Vee block

J—Adjustable packer

Fig. 1. Impact testing machine

BRITISH STANDARDS

The following are available on application:

BSI CATALOGUE

Including numerical lists of publications and alphabetical subject index

SECTIONAL LISTS

- Aerospace materials and components (SL 25)
- Agricultural, dairying and allied interests (SL 31)
- Automobile (SL 34)
- Building (SL 16)
- Chemical engineering (SL 5)
- Chemicals, fats, glues, oils, soaps, etc. (SL 4)
- Cinematography and photography (SL 1)
- Coal, coke, mining and quarrying requisites (SL 13)
- Codes of Practice (SL 8)
- Consumer goods (SL 3)
- Documentation, including Universal Decimal Classification (UDC) (SL 35)
- Drawing office practice (SL 37)
- Electrical engineering: power, electronics, telecommunications, acoustics, electro-acoustics, illumination, domestic appliances (SL 26)
- Furniture, bedding and furnishings (SL 11)
- Gardening, horticulture and landscape work (SL 41)
- Gas and solid fuel and refractories (SL 2)
- General management, quality assurance, quality control and statistics (SL 44)
- Glass, glassware and glazing (excluding laboratory apparatus) (SL 39)
- Guide for teachers in consumer education (SL 45)
- Guide for teachers in technical education (SL 46)
- Heating, ventilating, air conditioning and refrigeration (SL 42)
- Hospital equipment (SL 18)
- Industrial process measurement and control (SL 17)
- Iron and steel (SL 24)
- Laboratory apparatus (SL 23)
- Leather, plastics, rubber (SL 12)
- Local authority purchasing (SL 28)
- Machine tools (SL 20)
- Mechanical engineering (SL 6)
- Nomenclature, symbols and abbreviations (SL 29)
- Non-ferrous metals (SL 19)
- Nuclear energy (SL 36)
- Office machines and data processing (SL 43)
- Packaging and containers (SL 15)
- Paints, varnishes, paint ingredients and colours for paints, etc. (SL 9)
- Petroleum industry (SL 38)
- Printing and stationery, paper and board (SL 22)
- Road engineering (SL 32)
- Safety equipment (SL 30)
- Shipbuilding and marine (SL 40)
- Textiles and clothing (SL 33)
- Welding (SL 7)

Applications should be addressed to:

BRITISH STANDARDS INSTITUTION

Sales Administration

Linford Wood, Milton Keynes MK14 6LE

(Telephone Milton Keynes (0908) 320033)

BRITISH STANDARDS INSTITUTION

The British Standards Institution was founded in 1901 and incorporated by Royal Charter in 1929.

The principal objects of the Institution as set out in the charter are to co-ordinate the efforts of producers and users for the improvement, standardization and simplification of engineering and industrial materials; to simplify production and distribution; to eliminate the waste of time and material involved in the production of an unnecessary variety of patterns and sizes of articles for one and the same purpose; to set up standards of quality and dimensions, and to promote the general adoption of British Standards.

In carrying out its work the Institution endeavours to ensure adequate representation of all viewpoints. Before embarking on any project it must be satisfied that there is a strong body of opinion in favour of proceeding and that there is a recognized need to be met.

The Institution is a non-profit-making concern. It is financed by subscriptions from members—individuals, companies, technical and trade associations, and other bodies interested in its work, by a Government grant and by the sale of its publications. Membership of the Institution confers a number of specific rights and privileges. The demands on the services of the Institution are steadily increasing and can only be met if continuing and increased support is provided by those who use British Standards.

8504-5-0.4k-B