

BRITISH STANDARD

Slide fasteners (Zips) – Specification

ICS 61.040

Publishing and copyright information

The BSI copyright notice displayed in this document indicates when the document was last issued.

© BSI 2006

ISBN 0 580 48109 3

The following BSI references relate to the work on this standard:

Committee reference TCI/66

Draft for comment 05/30079180 CD

Publication history

First published January 1959

Second edition April 1963

Third edition April 1981

Fourth edition April 1992

Fifth edition April 2006

Amendments issued since publication

Amd. no.	Date	Text affected
-----------------	-------------	----------------------

Contents

Foreword *iii*

1	Scope	<i>1</i>
2	Normative references	<i>2</i>
3	Terms and definitions	<i>2</i>
4	Performance requirements for fasteners	<i>4</i>
5	Conditioning and testing	<i>5</i>
6	Washing and dry cleaning test	<i>7</i>
7	Test report	<i>7</i>
8	Marking	<i>7</i>

Annexes

Annex A (informative)	Guidance on factors to be taken into consideration when specifying fasteners	<i>12</i>
Annex B (normative)	Test for strength of puller attachment	<i>12</i>
Annex C (normative)	Test for strength of closed-end	<i>14</i>
Annex D (normative)	Test for strength of top stop	<i>15</i>
Annex E (normative)	Test for strength of open-end fastener box	<i>16</i>
Annex F (normative)	Test for resistance to reciprocation	<i>17</i>
Annex G (normative)	Test for lateral strength of fastener	<i>20</i>
Annex H (normative)	Test for lateral strength of open-end attachment	<i>21</i>
Annex I (normative)	Test for strength of slider locking device	<i>22</i>
Annex J (normative)	Test for open-end fastener single stringer slider retention	<i>23</i>
Annex K (informative)	Sampling procedures for bulk quantities of fasteners	<i>24</i>

Bibliography *25*

List of figures

Figure 1 – Fastener chain types	<i>9</i>
Figure 1 – Fastener chain types (<i>continued</i>)	<i>10</i>
Figure 2 – Fasteners: basic components and dimensions	<i>10</i>
Figure 3 – One-way fasteners	<i>11</i>
Figure 4 – Two-way fasteners	<i>11</i>
Figure B.1 – Puller attachment test	<i>13</i>
Figure C.1 – Closed-end test	<i>14</i>
Figure D.1 – Top stop test	<i>15</i>
Figure E.1 – Open-ended fastener box test	<i>16</i>
Figure F.1 – Resistance to reciprocation test	<i>18</i>
Figure G.1 – Lateral strength test	<i>20</i>
Figure H.1 – Lateral strength of open-end attachment test	<i>21</i>
Figure I.1 – Slider locking test	<i>22</i>
Figure J.1 – Open-end fastener single stringer slider retention test	<i>23</i>

List of tables

Table 1 – Performance requirements of fasteners according to end use 4

Table 2 – Additional requirements of fasteners 5

Table 3 – End uses and performance codes for labelling purposes 8

Table F.1 – Lateral and longitudinal applied forces for reciprocating test 19

Table K.1 – Batch sizes and test rates 24

Summary of pages

This document comprises a front cover, an inside front cover, pages i to iii, a blank page, pages 1 to 25 and a back cover.

Foreword

This British Standard has been prepared by Technical Committee TCI/66, *Apparel and interior textiles*. It supersedes BS 3084:1992, which is withdrawn.

A list of organizations represented on TCI/66 can be obtained on request to its secretary.

The first edition of this British Standard was published in January 1959. It was not possible at that time to include tests for the pin and socket fitting of open-end fasteners, and the main purpose of the 1963 revision was to cover that type of fitting.

In the 1981 edition, fasteners were coded not according to their size, as they were in previous editions, but to their performance levels, so that fasteners could be selected taking into account their end use, not their size. This approach has been followed in subsequent editions.

BS 3084:1992 incorporated Amendment 1 to BS 3084:1981 and introduced technical changes and corrections to conform to current practice.

The 2006 edition represents a full review of the standard to meet the needs of current users. The test methods have been extended to accommodate the practice of testing to failure, rather than merely terminating each test when the specified performance level has been met, as in earlier editions. Testing to failure is the more common method currently as, combined with the application of statistical techniques, it generates more meaningful information about the capabilities of products and processes, compared with the alternative pass or fail results. Nothing in this standard precludes this practice.

Similarly, previous versions recommended a sampling procedure based on batch sizes, but inspection by variables is considered to be more appropriate than inspection by attributes, so the annex that formerly dealt with this has been retained only as an informative annex. Users wishing to continue using such sampling plans are recommended to consult BS 6001 for sampling procedures for inspection by attributes.

Previous editions specified additional colour fastness and dimensional stability requirements for fasteners to be sold direct to the public. These requirements have now been incorporated as minimum requirements for all fasteners, to reflect the needs of current users.

This publication does not purport to include all the necessary provisions of a contract. Users are responsible for its correct application.

Compliance with a British Standard cannot confer immunity from legal obligations.

Introduction

The different types of slide fasteners are defined by the material of the elements (teeth), which form their fastener chains. They can be of metallic, moulded plastic or monofilament plastic construction.

Metallic elements can be produced from flat or profiled wire and are usually clamped around the edge of a beaded textile tape. An alternative approach is to cast metallic elements directly onto such a tape. Similarly, plastic elements can be moulded onto a beaded textile tape. Such cast or moulded elements might have projections on which the slider operates to reduce abrasion of the textile tape.

Plastic coil fasteners have nylon or polyester monofilaments that are wound into coils to form engaging elements. The coils can be attached to the face of flat textile tapes by sewing. Alternatively, the coils can be woven or knitted into the textile tapes as they are constructed. Monofilament plastic elements can also be of the meander type, which straddle the tape edge.

Typical fastener chain types are shown in Figure 1.

1 Scope

This British Standard specifies performance levels and test methods for the following characteristics of slide fasteners made from interlocking components mounted on textile tapes: strengths of puller attachment, closed-end, top stop, open-end fastener box, reciprocating mechanism, closed fastener when extended laterally, open-end attachment when extended laterally, slider lock, and open-end fastener single stringer slider retention.

NOTE The tests specified in Annexes B to J have been specifically devised to permit their direct application to finished fasteners with a view to giving the user reasonable assurance that a fastener conforming to the requirements of this British Standard can satisfactorily fulfil its intended purpose. Annex K gives information about sampling procedures for bulk quantities of fasteners.

In addition, performance levels are also specified for colour fastness to washing, dry cleaning and water, and for dimensional stability to washing and dry cleaning.

This British Standard is applicable to slide fasteners for general use and is not applicable to slide fasteners for aeronautical or other specialist purposes (slide fasteners for aeronautical purposes are covered by BS 3F 121).

2 Normative references

The following referenced documents are indispensable for the application of this document. For dated references, only the edition cited applies. For undated references, the latest edition of the referenced document (including any amendments) applies.

BS EN 25077, *Textiles – Determination of dimensional change in washing and drying.*

BS EN ISO 139, *Textiles – Standard atmospheres for conditioning and testing.*

BS EN ISO 105-C06:1997, *Textiles – Tests for colour fastness – Part C06: Colour fastness to domestic and commercial laundering.*

BS EN ISO 105-D01, *Textiles – Tests for colour fastness – Part D01: Colour fastness to dry cleaning.*

BS EN ISO 105-E01, *Textiles – Tests for colour fastness – Part E01: Colour fastness to water.*

BS EN ISO 3175-2, *Textiles – Dry cleaning and finishing – Part 2: Procedures for tetrachloroethene.*

BS EN ISO 6330, *Textiles – Domestic washing and drying procedures for textile testing.*

3 Terms and definitions

For the purposes of this standard the following terms and definitions apply.

3.1 slide fastener (zip)

fastening device consisting of two flexible, interlocking stringers, with or without end stops, and a slider so arranged that by moving the slider along the stringers in one direction an opening is formed, and by moving it in the other the opening is closed

NOTE 1 Hereinafter referred to as “fastener”.

NOTE 2 The end which is adjacent to the slider when the device is fully open is designated the bottom end. The other end is designated the top end.

3.2 batch

quantity of fasteners having one design, one performance code and one size

3.3 bottom stop

stop at the bottom end of the chain that checks the opening movement of the slider

NOTE See Figure 2a).

3.4 chain

continuous closure formed by two interlocking compatible stringers

3.5 chain width

width across the interlocked elements or shoulder on which the slider runs, whichever is the greater

NOTE See Figure 2b).

3.6 elements

metal or plastic teeth fixed to the edge of tapes which engage or separate from each other under the action of the slider

3.7 fastener length

distance from the top of the slider to the bottom of the bottom stop, or box in the case of an open-end fastener, measured with the slider in the top position and with the puller in the downward position

NOTE See Figure 2b) and c).

3.8 locking device

device incorporated in the slider unit restricting its free movement along the fastener length in an opening direction

NOTE The locking device might operate either automatically on release of the puller or by manual pressure on the puller.

3.9 puller

fitting attached to the slider to facilitate manipulation

3.10 slider

moving component consisting essentially of a slider body and, normally, a puller which opens or closes the fastener by separating or engaging the interlocking members

NOTE The slider might incorporate a locking device. Alternative slider types are available with a flip-over puller or double pullers, to facilitate operation from both front and back sides.

3.11 stringer

textile tape with an attached row of elements designed to interlock with a row similarly attached to another tape

3.12 tape

narrow fabric to which elements are fitted

3.13 top stop

stop(s) at the top end of the chain that check(s) the closing movement of the slider

3.14 closed-end fastener

fastener which does not permit the complete separation of the two stringers

NOTE Normally the top end of the fastener separates as the slider is lowered, although there is one type whose top ends are permanently joined together by means of a bridge stop [see Figure 3a) and Figure 3b)].

3.15 concealed fastener

fastener with the tapes folded so that on closure neither the slider body nor the fastener are visible from the outside of the article

NOTE See Figure 1g).

3.16 open-end fastener

fastener having a special fitment at the bottom end of each stringer in place of the bottom stop, so as to permit the two stringers to be completely separated and re-assembled at will when the slider is in the fully open position [see Figure 3c)]

NOTE The special fitment normally consists of a pin permanently fixed to the bottom end of one stringer, which fits into a box permanently fixed to the bottom end of the other stringer.

3.17 two-way fastener

fastener fitted with two sliders that operate with equal facility in either direction

NOTE This type is available in a variety of forms, as illustrated in Figure 4.

4 Performance requirements for fasteners

When subjected to the tests specified in Clause 5, other than the fastener length measurements (see 5.2), samples of new and unused fasteners shall conform to Table 1.

NOTE 1 It is permissible to perform more than one test on the same fastener but care should be taken to ensure that damage sustained in testing does not compromise subsequent test results.

Annex K gives information about an appropriate sampling procedure for bulk quantities of fasteners. Failure of any part of a fastener before the specified force or number of cycles is reached in any of these tests shall be deemed a failure for batch acceptance or rejection purposes.

Table 1 Performance requirements of fasteners according to end use

Annex	Test description	Units	Performance code ^{A)}				
			A	B	C	D	E
B	Strength of puller attachment (min.)	N	70	80	200	250	300
C	Strength of closed-end (min.)	N	35	60	80	100	140
D	Strength of top stop (min.)	N	50	70	90	110	130
E	Strength of open-end fastener box (min.)	N	40	70	90	120	150
F	Resistance to reciprocation: minimum cycles without failure	cycles	500	500	500	500	500
G	Lateral strength of fastener (min.)	N	150	200	250	370	470
H	Lateral strength of open-end attachment (min.)	N	40	70	90	120	160
I	Strength of slider locking device (min.)	N	10	15	25	40	60
J	Open-end fastener single stringer slider retention (min.)	N	N/A ^{B)}	60	70	90	120

^{A)} These performance codes correspond to the descriptions of fastener type used in BS 3084:1963 as follows:
A (ultra-light), B (light), C (medium), D (medium-heavy) and E (heavy).

^{B)} Not Applicable.

NOTE 2 BS 7907 gives particular recommendations for the mechanical safety of children's clothing.

In addition, to the requirements of Table 1, fasteners shall conform to the colour fastness and dimensional stability requirements of Table 2.

Table 2 **Additional requirements of fasteners**

Property	Method of test	Performance level
Colour fastness ^{A)} (minimum rating) to:		
dry cleaning	BS EN ISO 105-D01	Change in colour and staining 3-4
washing	BS EN ISO 105-C06:1997, Method A2S	Change in colour and staining 3-4
water	BS EN ISO 105- E01	Change in colour and staining 3-4
Maximum dimensional change on:		
washing	BS EN 25077 ^{B),C)}	– 4% of original length
dry cleaning	BS EN ISO 3175-2 ^{C)}	– 3% of original length

A) Colour change and staining measured using the Grey scale.

B) Using washing procedure 5A and drying procedure E at a temperature not exceeding 70 °C as described in BS EN ISO 6330.

C) Except that the change in fastener length only, as defined in 3.7, shall be determined.

NOTE 3 Guidance on the factors to be considered when specifying fasteners is given in Annex A.

5 Conditioning and testing

5.1 Conditioning of test samples

Prior to being subjected to the tests specified in 5.2 to 5.11, sample fasteners shall first be conditioned for 16 h and then tested in the standard temperate atmosphere for testing textiles as defined in BS EN ISO 139, i.e. a temperature of 20 ± 2 °C and a relative humidity of $65 \pm 4\%$.

5.2 Fastener length measurement

The length tolerance for fasteners shall be $\pm 1.5\%$ or ± 3 mm, whichever is the greater.

5.3 Strength of puller attachment

When tested in accordance with Annex B, fasteners shall conform to the marked rating specified in Table 1 for a given end use (see also Table 3).

5.4 Strength of closed-end

When tested in accordance with Annex C, closed-end fasteners shall conform to the marked rating specified in Table 1 for a given end use (see also Table 3).

5.5 Strength of top stop

When tested in accordance with Annex D, fasteners shall conform to the marked rating specified in Table 1 for a given end use (see also Table 3).

5.6 Strength of open-end fastener box

When tested in accordance with Annex E, fasteners shall conform to the marked rating as specified in Table 1 for a given end use (see also Table 3). This method may also be applied to test the retention of the lower slider on two-way open-end fasteners.

5.7 Resistance to reciprocation

When tested in accordance with Annex F, a fastener 200 mm or longer shall complete 500 cycles without failure.

If a fastener is less than 200 mm long the test shall be carried out on either a suitably lengthened fastener or on a similar type but of length greater than 200 mm.

5.8 Lateral strength of fastener

When tested in accordance with Annex G, fasteners shall conform to the marked rating specified in Table 1 for a given end use (see also Table 3).

5.9 Lateral strength of open-end attachment

When tested in accordance with Annex H, fasteners shall conform to the marked rating specified in Table 1 for a given end use (see also Table 3).

5.10 Strength of slider locking device

When tested in accordance with Annex I, a slider fitted with a locking device shall withstand the lateral force specified in Table 1 for the given end use (see also Table 3) when the lock is engaged and the stringers are pulled at right angles to the length of the fastener (see Figure I.1).

5.11 Open-end fastener single stringer slider retention

When tested in accordance with Annex J, fasteners shall conform to the marked rating specified in Table 1 for a given end use (see also Table 3).

NOTE Examples of a wide range of end uses of fasteners are given in Table 3. These are grouped into five performance codes A to E, with category E being the most stringent. Each of the physical tests in this clause relates to the five performance codes, A to E, given in Table 1, which correspond to the performance codes of the end uses in Table 3. The relative position of each end use in Table 3 is based on currently accepted practice, and judgement should be exercised on the likely requirements when selecting a fastener for a particular end use.

6 Washing and dry cleaning test

When particular post-washing/dry cleaning performance levels are specified for fasteners, samples of these shall be tested in accordance with Clause 5 after subjecting them to one or both of the following procedures, as appropriate.

- a) One wash and dry in accordance with, respectively, procedure 5A and procedure E specified in BS EN ISO 6330.
- b) One dry cleaning cycle in accordance with BS EN ISO 3175-2.

NOTE After dry cleaning the application of a suitable lubricant prior to reciprocation is acceptable.

7 Test report

The test report shall include the following information:

- a) identification of the batch of fasteners being tested;
- b) a statement that the tests have been performed in accordance with BS 3084:2006, including the relevant performance code;
- c) a description of any deviation from the test methods specified in BS 3084:2006;
- d) the numerical results obtained for each test or confirmation that each result was a pass; and
- e) a description of any washing or dry cleaning procedures performed and any observed effects of these procedures.

8 Marking

The following information shall be indicated on the package, the swing ticket or any accompanying commercial documents:

- a) the name of the manufacturer;
- b) the number and date of this British Standard, i.e. BS 3084:2006¹⁾;
- c) the performance code of the fastener, as given in Table 1;
- d) information on end use, as given in Table 3;
- e) details of fastener type, length, colour, chain and tape width, element material and any special characteristics or manufacturer's identification which defines these details.

¹⁾ Marking BS 3084:2006 on or in relation to a product represents a manufacturer's declaration of conformity, i.e. a claim by or on behalf of the manufacturer that the product meets the requirements of the standard. The accuracy of the claim is therefore solely the responsibility of the person making the claim. Such a declaration is not to be confused with third party certification of conformity, which may also be desirable.

Table 3 End uses and performance codes for labelling purposes

End uses	Performance code				
	A	B	C	D	E
Dresses	_____	_____			
Knitwear	_____	_____	_____		
Light leather goods	_____	_____			
Skirts, jeans or trousers		_____	_____		
Upholstery		_____	_____		
Foundation garments			_____		
Coats and jackets			_____	_____	
Overalls			_____		
Luggage			_____	_____	_____
Slippers			_____		
Sleeping bags			_____	_____	
Lightweight and inner tents			_____	_____	
Footwear				_____	_____
Leather garments				_____	
Ski clothes				_____	
Wet suits					_____
Awnings and frame tents					_____

NOTE Advice on the end use of fasteners should be indicated at the point of sale using the information given in Table 3 and Annex A. For industrial users a technical advisory service is made available by most manufacturers. Some end-use categories given in Table 3 overlap several performance codes; this is because certain items, e.g. knitwear, are manufactured in various weights and thus are designed for a variety of end uses. Users of this standard should therefore use their judgement in selecting a performance code following the guidance given in Table 3.

Figure 1 Fastener chain types

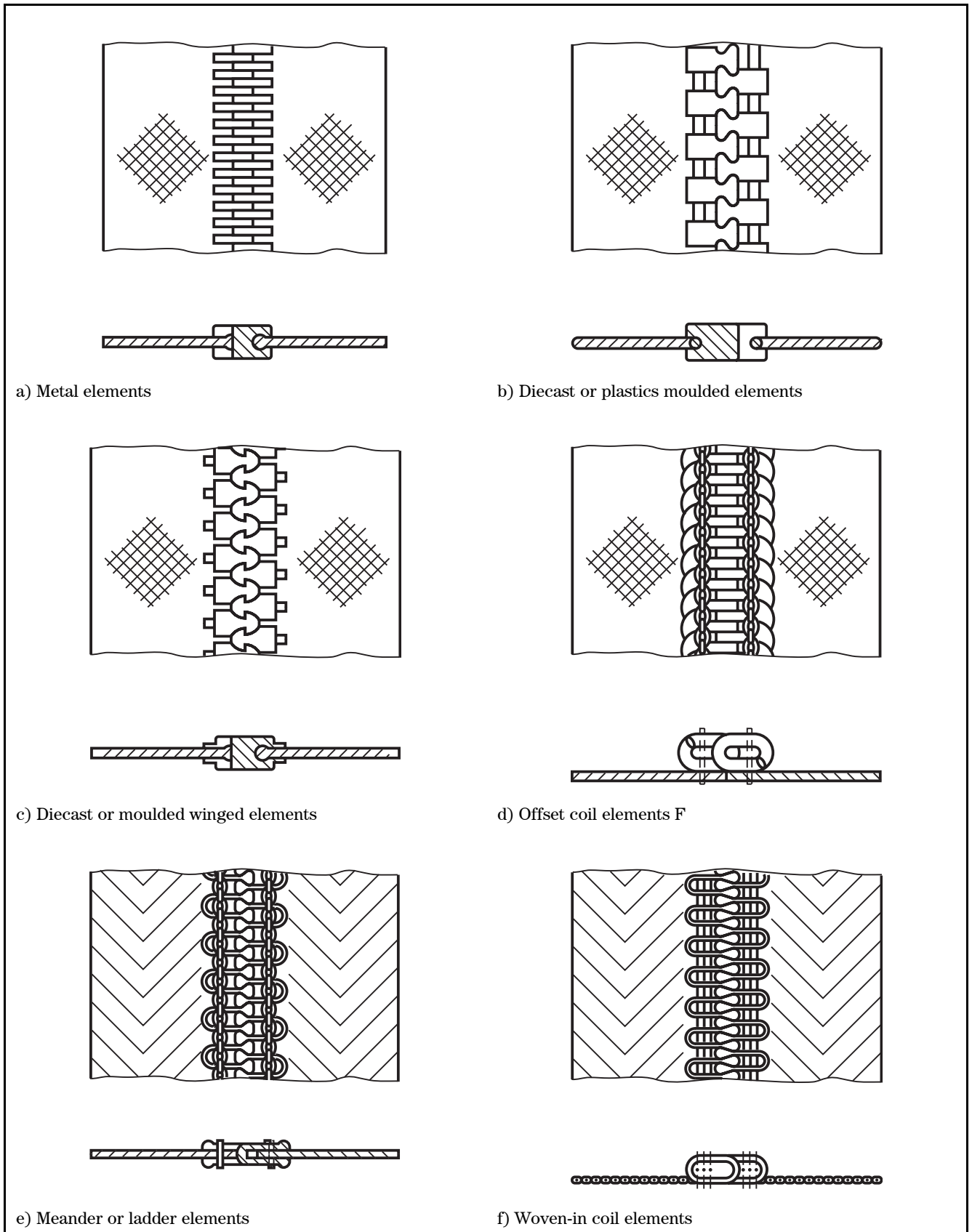

Figure 1 Fastener chain types (*continued*)

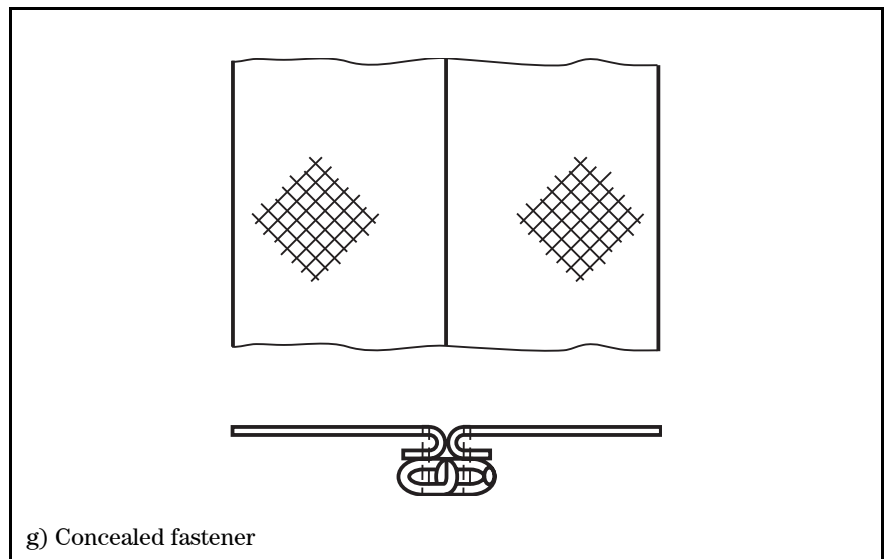

Figure 2 Fasteners: basic components and dimensions

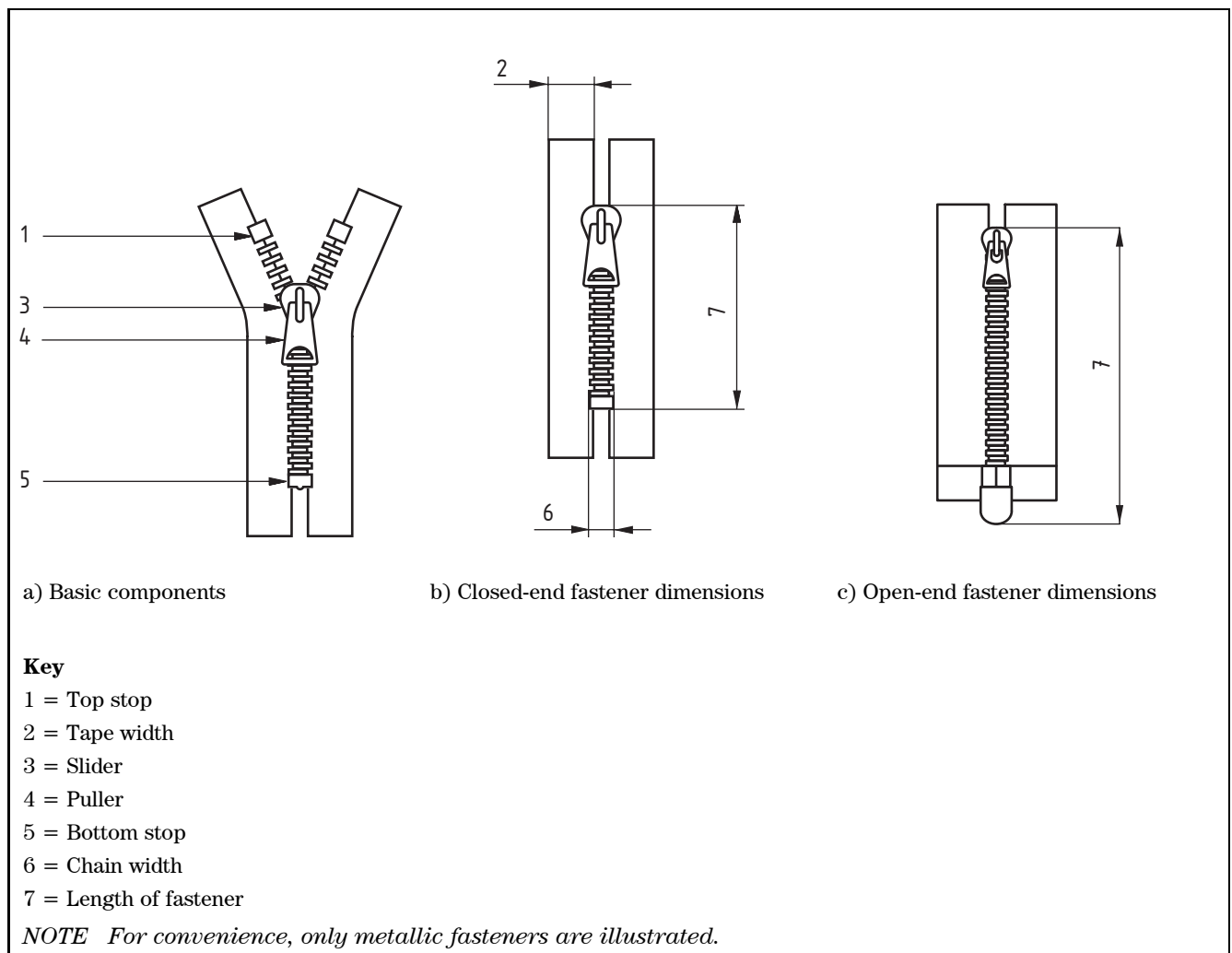

Figure 3 One-way fasteners

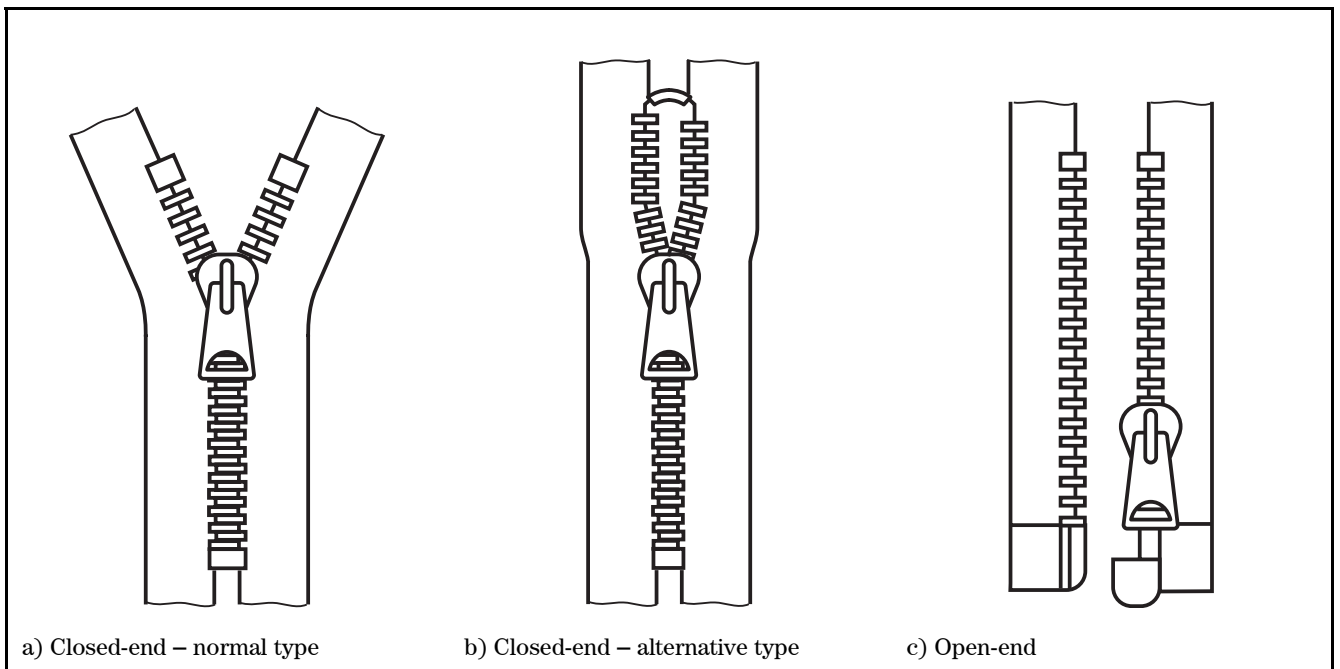
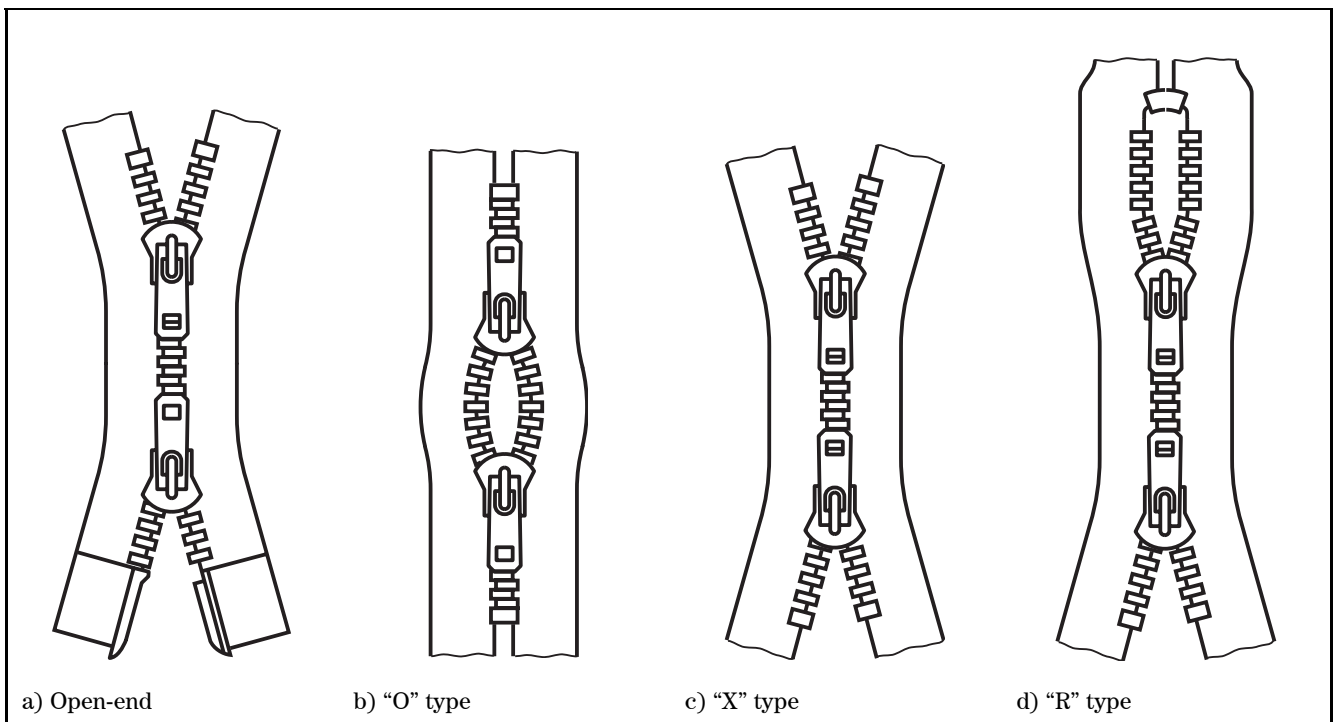

Figure 4 Two-way fasteners



Annex A (informative)

Guidance on factors to be taken into consideration when specifying fasteners

The following information should be included when specifying fasteners:

- a) the type of fastener;
- b) the fabric construction used in the tape;
- c) the type and material of the elements;
- d) the fastener length;
- e) the chain width;
- f) the tape width, as shown in Figure 2b);
- g) the slider type;
- h) the performance codes of the fastener for the tests, as indicated in Table 3; and
- i) any other special features of the fastener.

Annex B (normative)

Test for strength of puller attachment

B.1 Principle

The puller is subjected to tension whilst the slider is rigidly supported.

B.2 Apparatus

B.2.1 *constant rate of extension tensile testing machine*, which conforms to BS EN ISO 7500-1 and produces a rate of gripping jaw separation of 100 ± 15 mm/min. The force range is such that the breaking strength of the test specimen falls between 15% and 90% of the maximum on the scale.

NOTE 1 It is recommended that the force scale be calibrated at least once every 12 months, using successively added dead weights or approved strain rings.

NOTE 2 Since calibration of these machines is normally carried out with the maximum-reading device inoperative, the use of a maximum-reading device at low forces may introduce serious errors.

B.2.2 *masking device for the slider*, such as a face-plate or a blanking-off plate, to confine the tension to the puller and its attachment to the slider (see Figure B.1).

B.3 Procedure

Mount the test specimen in one gripping jaw of the tensile testing machine, with the puller passed through a hole in the masking device. Arrange the masking device so that the slider and the chain are rigidly clamped in place, with only the puller and its attachment to the slider being free. Secure the end of the puller to the other gripping jaw so that tension is applied at 90° to the face of the slider. Set the testing machine in operation until the specified force is reached or the specimen fails.

Figure B.1 Puller attachment test

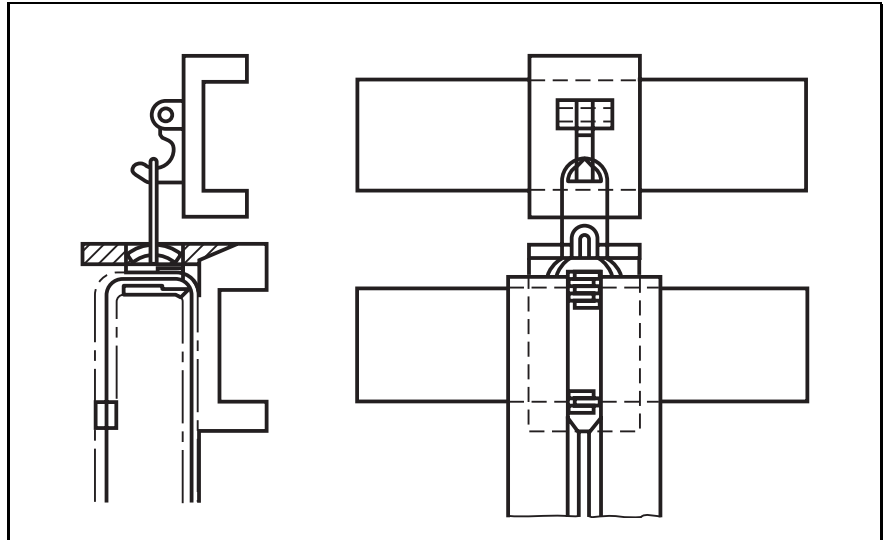

Annex C (normative) Test for strength of closed-end

C.1 Principle

The bottom stop is subjected to a force via the slider by tension applied to the stringers.

C.2 Apparatus

C.2.1 *constant rate of extension tensile testing machine, as described in Annex B (see Figure C.1).*

Figure C.1 Closed-end test

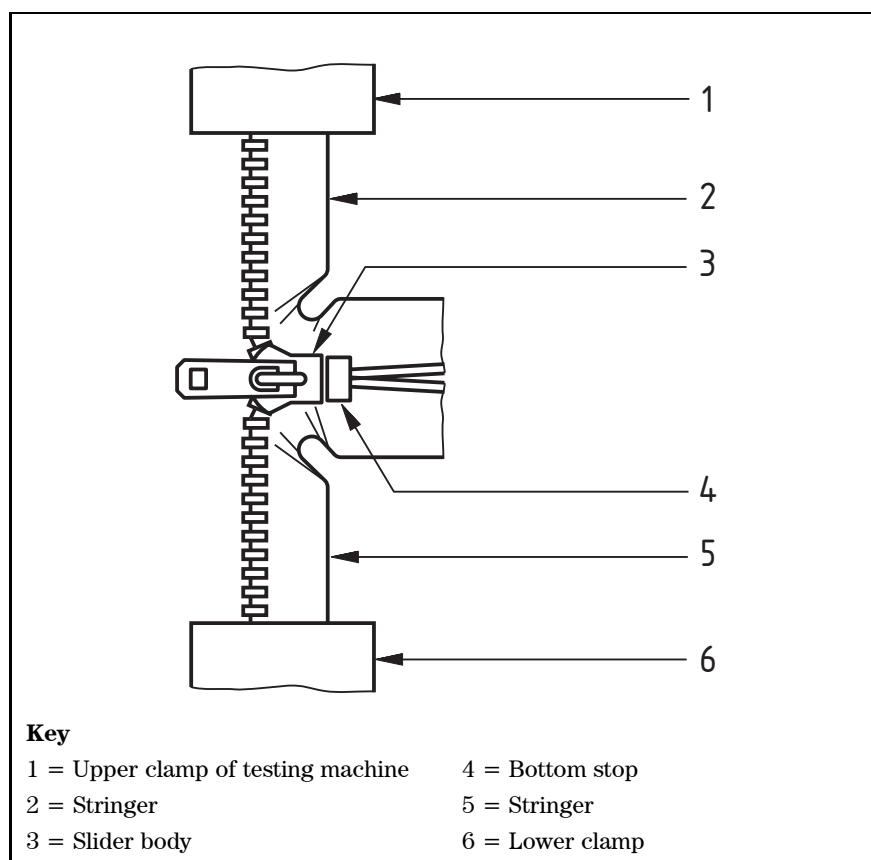

C.3 Procedure

With the test specimen in its open position and the slider adjacent to the bottom stop, clamp one stringer in each of the two gripping jaws approximately 10 cm away from the slider. (This might be better achieved by cutting away the surplus stringer). Ensure that the locking mechanism is inoperative. Apply a longitudinal force to the stringers thus forcing the slider against the bottom stop. Set the machine in operation until the specified force is reached or the specimen fails.

NOTE Instances of failure include slipping of the bottom stop and removal of adjacent elements.

Annex D (normative) Test for strength of top stop

D.1 Principle

The top stop is subjected to a force via the slider applied through the puller.

D.2 Apparatus

D.2.1 *constant rate of extension tensile testing machine, as described in Annex B (see Figure D.1).*

Figure D.1 Top stop test

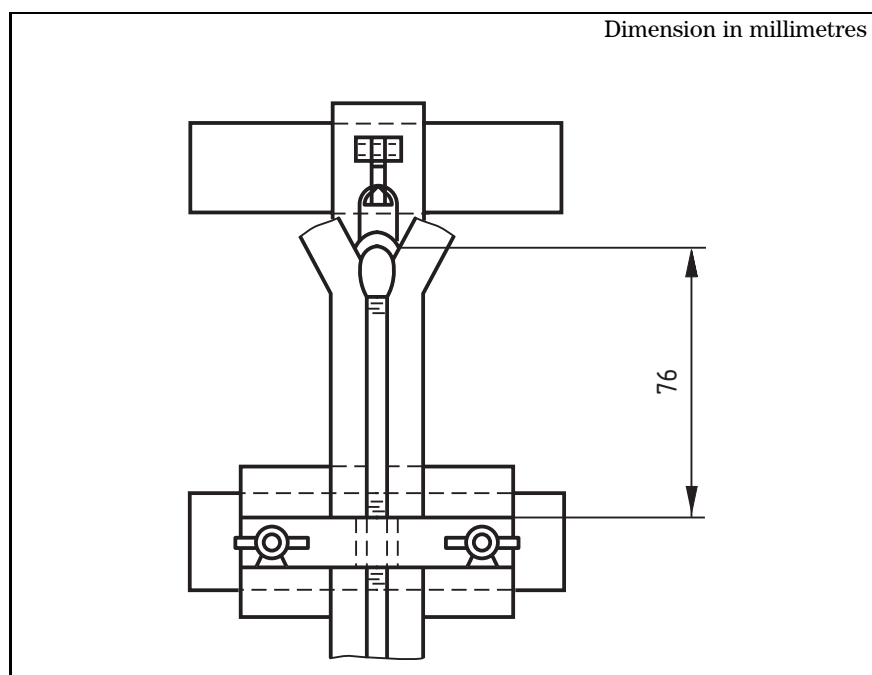

D.3 Procedure

With the test specimen in its closed position and the slider adjacent to the top stop secure the puller in one gripping jaw of the machine and the other end of the specimen in the other gripping jaw, taking care to avoid damaging the chain. Set the machine in operation until the specified force is reached or the specimen fails.

NOTE Instances of failure include slipping of the top stops, the slider riding over the top stops and the slider coming apart.

Annex E (normative) Test for strength of open-end fastener box

E.1 Principle

The box is subjected to longitudinal force whilst the fastener chain is in the closed position.

E.2 Apparatus

E.2.1 *constant rate of extension tensile testing machine, as described in Annex B (see Figure E.1).*

Figure E.1 **Open-ended fastener box test**

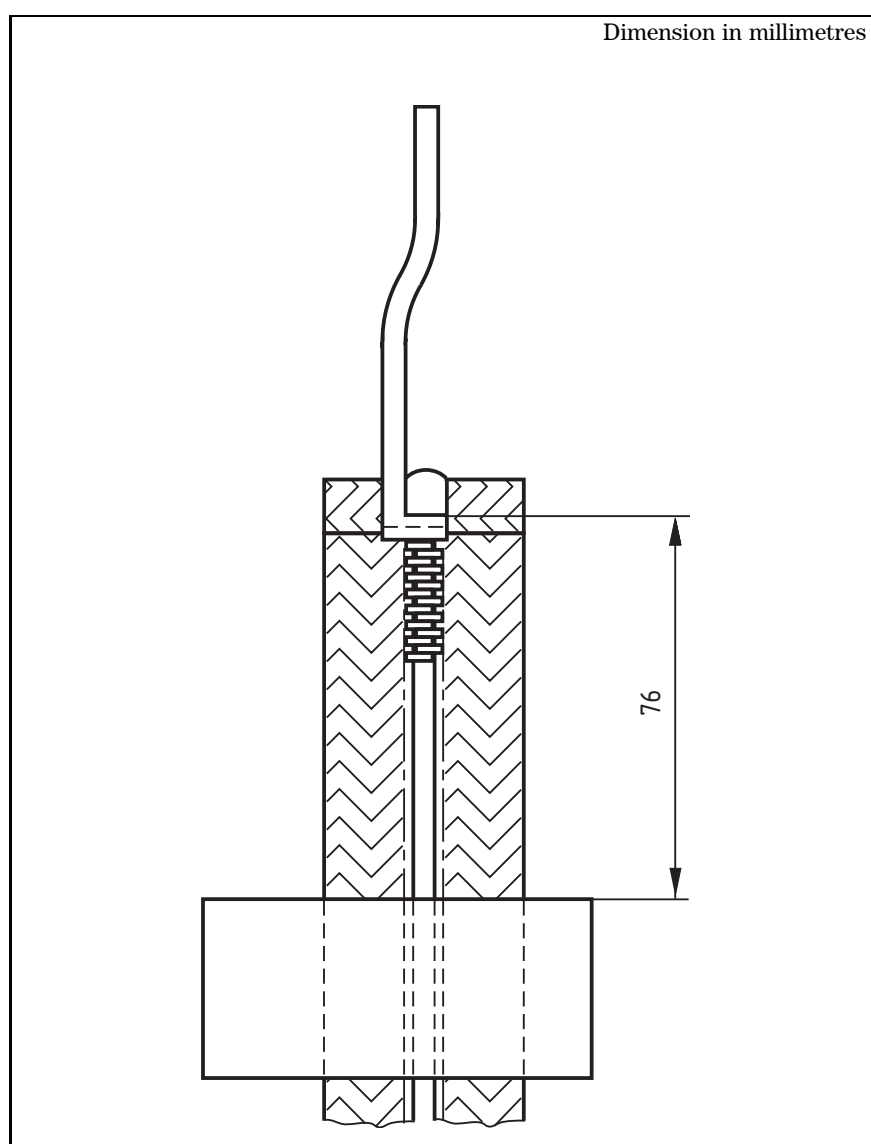

E.3 Procedure

With the test specimen in the closed position, clamp the interlocked chain into one gripping jaw of the testing machine, taking care to avoid damaging the chain. Clamp a slotted plate, shaped to clear the tape, chain and pin and to bear against the whole of the top edges of the box (see note to **3.16**), into the other gripping jaw. (Alternatively clamp the puller of the lower slider of a two-way open-ended fastener into the upper gripping jaw.) Set the machine in operation until the specified force is reached or the test specimen fails.

Annex F (normative) Test for resistance to reciprocation

F.1 Principle

The test specimen is subjected to a specified number of cyclic operations whilst under lateral and longitudinal tension.

F.2 Apparatus

F.2.1 *Vertically operated testing machine of the type shown in Figure F.1 and providing the following facilities.*

- a) Means of holding the test specimen firmly at the bottom end, with the fastener in the closed position, without the chain being damaged.
- b) Means of separately gripping the two stringers at the other end so that the fastener beyond the slider is open. These gripping devices form the means of applying longitudinal spring balance forces to the fastener and are therefore connected together by a swivel-plate or other similar device, so that the fastener can be centralized when the forces are applied. The gripping devices also swivel at the points of connection to the swivel-plate to facilitate the operation of the slider on the test specimen. The distance between the gripping devices is such that when the slider is at the lowest point in the cycle the two ends of the fastener subtend an angle of approximately 60° (see Figure F.1).
- c) Means of gripping the tapes securely midway along the traversed length at opposite points of the testing zone so that the clamps can be subjected to force by means of spring balances. The clamps are mounted so that they are “floating”, i.e. free to follow the natural direction of opening of the test specimen.

The clamps are capable of moving 5 mm in the direction of the pulleys, and setting pads are provided to hold the clamps in position until they are secured to the tapes.

The spring balances are of the tubular type and are 100 N balances for the lateral tension and 50 N balances for the longitudinal force. In each case the scale is 44 mm in length. The 100 N balance has a spring rating of 2.25 N/mm and the 50 N balance one of 1.10 N/mm. They are graduated in 1 N steps and accurate to within 5 N on each reading.

- d) Means of applying a regular reciprocating action, through the medium of the puller, to the slider on the test specimen. The clamp or other gripping device may provide an indirect form of connection in which the clamp is in two parts, one of which is attached to the reciprocating device and the other to the puller on the specimen. This method of attachment can incorporate a spring mechanism or other feature to withdraw any automatic locking device fitted to the slider on the specimen.

Figure F.1 Resistance to reciprocation test

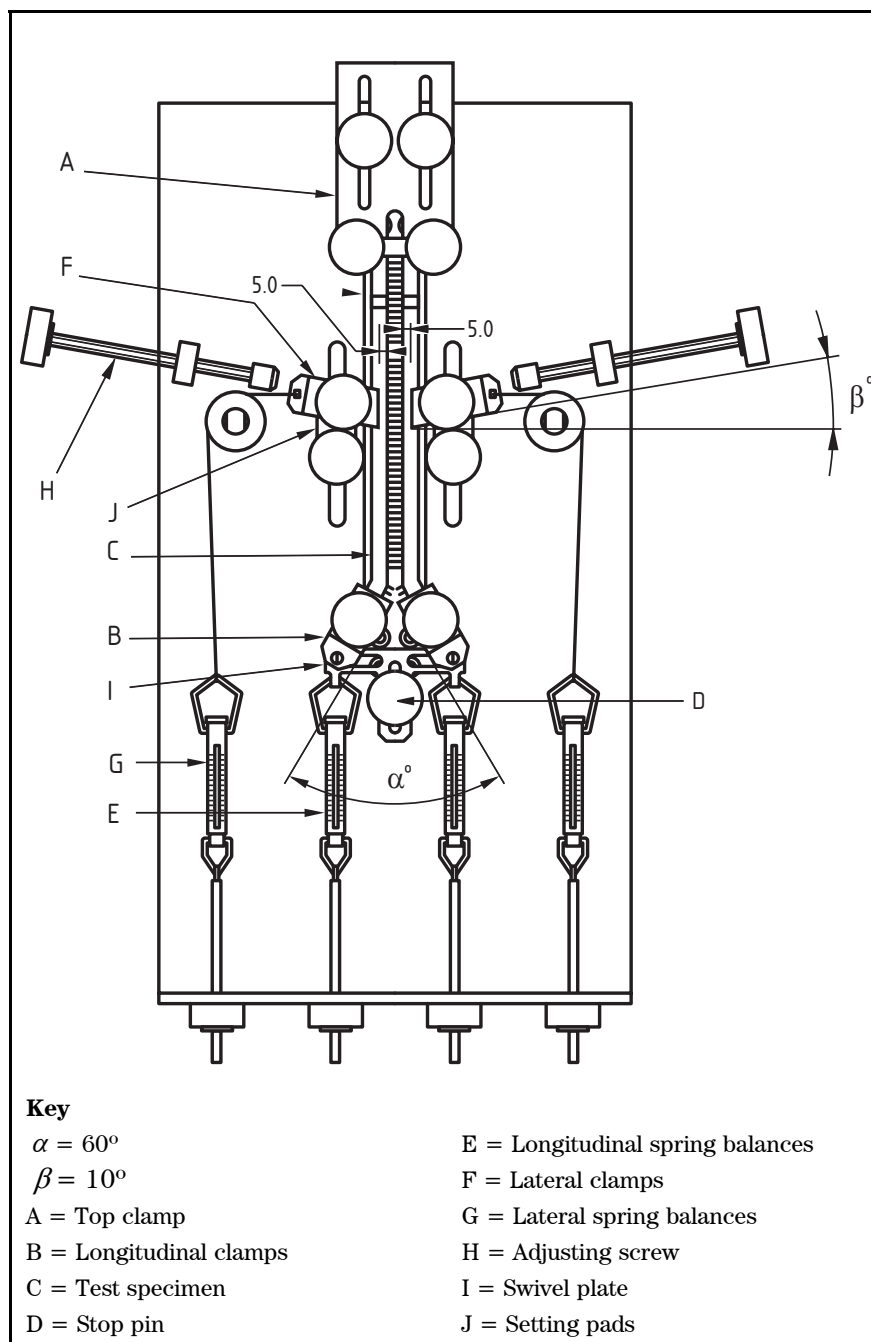

F.3 Procedure

F.3.1 Mount the test specimen in the vertical plane so that the bottom stop is away from the spring balance end of the testing machine. Leave the stringers separate at the other end so that they can be individually mounted in the testing machine (see Figure F.1). The lateral and longitudinal forces applied are as given in Table F.1.

Table F.1 **Lateral and longitudinal applied forces for reciprocating test**

Performance code	Lateral force on each stringer	Longitudinal force on each stringer
	N	N
A	7	5
B	10	9
C	16	14
D	24	18
E	30	23

F.3.2 Arrange the machine so that the length of traverse of the slider is from 75 mm to 90 mm in each direction, a to-and-fro movement of 150 mm to 180 mm forming a cycle. The procedure then follows the steps indicated below.

1. Operate the testing machine by hand until the slider gripper is in the lowest position, and place in position the setting pads.
2. Clamp the puller, ensuring that any locking device is withdrawn.
3. Place the fastener loosely in position in the top tape clamp, A.
4. Secure the fastener ends in the bottom tape clamps, B.
5. Take hold of the fastener C at the upper end and draw upwards until pin D prevents any further upward movement, without stretching the tape. Tighten clamp A. If the fastener is completely closed, then the tape ends that are attached by the bottom tape clamps are too long. To overcome this, release clamps B, F and A and cut off a length of each bottom tape end. To re-assemble start at Step 3.
6. Apply the appropriate longitudinal forces given in Table F.1 by adjusting the spring balances E.
7. Secure side clamps F to the fastener tapes, leaving gaps of 5 mm between the side clamps and the chain at their nearest points. Ensure that the centre-lines of the clamps coincide with the strings that pass over the pulleys. Ensure that the clamps, F, are held firmly against the setting pads, J, whilst securing the clamps to the fastener tape. Withdraw the setting pads after fixing the clamps.
8. Apply the appropriate lateral forces given in Table F.1 by adjusting spring balances G.
9. Set the counter to zero. Set machine in motion for one cycle only to the equalize position of test specimen.
10. Check the forces of spring balances E and G and adjust when necessary. When the slider is in the lowest position set the adjusting screws, H, 5 mm away from the side clamps, F.

11. Set the machine in motion at a constant speed of 30 cycles per minute.
12. Once the test has started, do not readjust the spring balances E and G.
13. Leave the machine in operation until the specified number of cycles is completed or failure occurs.

Annex G (normative) Test for lateral strength of fastener

G.1 Principle

The test specimen is subjected to lateral force under controlled conditions whilst the fastener chain is in the closed position.

G.2 Apparatus

G.2.1 *constant rate of extension tensile testing machine*, as described in Annex B, with gripping jaws or other securing devices having a gripping surface 25.4 mm wide and constructed and finished such as not to damage the tape or allow the test specimen to slip (see Figure G.1).

Figure G.1 Lateral strength test

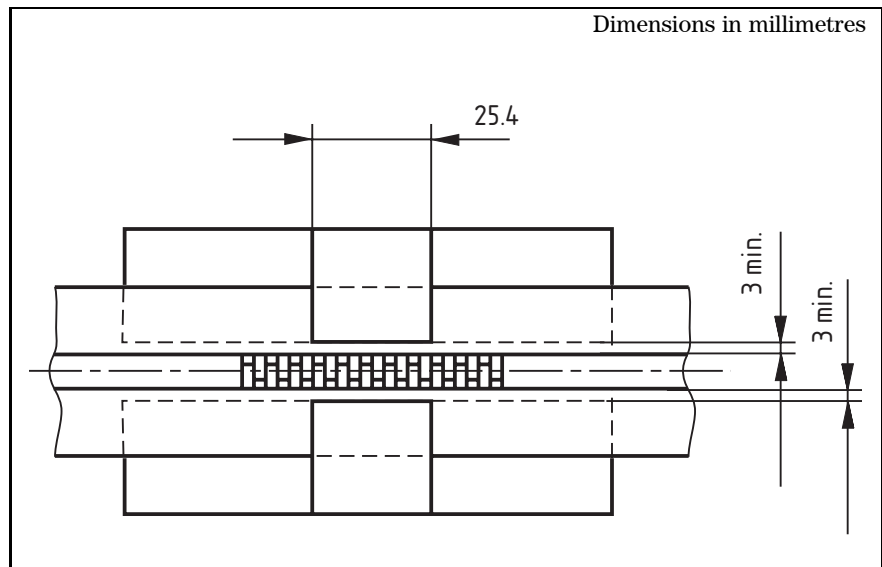

G.3 Procedure

Secure the test specimen in place with the gripping jaws so arranged that at least half the width of each tape is gripped and there is at least 25.4 mm of closed chain on each side. Set the testing machine in operation until the specified force is reached or the test specimen fails.

Annex H (normative) Test for lateral strength of open-end attachment

H.1 Principle

The test specimen is subjected to straight lateral force under controlled conditions whilst the fastener chain is in the closed position.

H.2 Apparatus

H.2.1 *constant rate of extension tensile testing machine*, as described in Annex B, with gripping jaws 6 mm wide for testing fasteners for performance codes A and B, and 12 mm wide for testing for performance codes C, D and E. The gripping jaws are so constructed and finished as not to damage the tape or to allow the test specimen to slip (see Figure H.1).

Figure H.1 Lateral strength of open-end attachment test

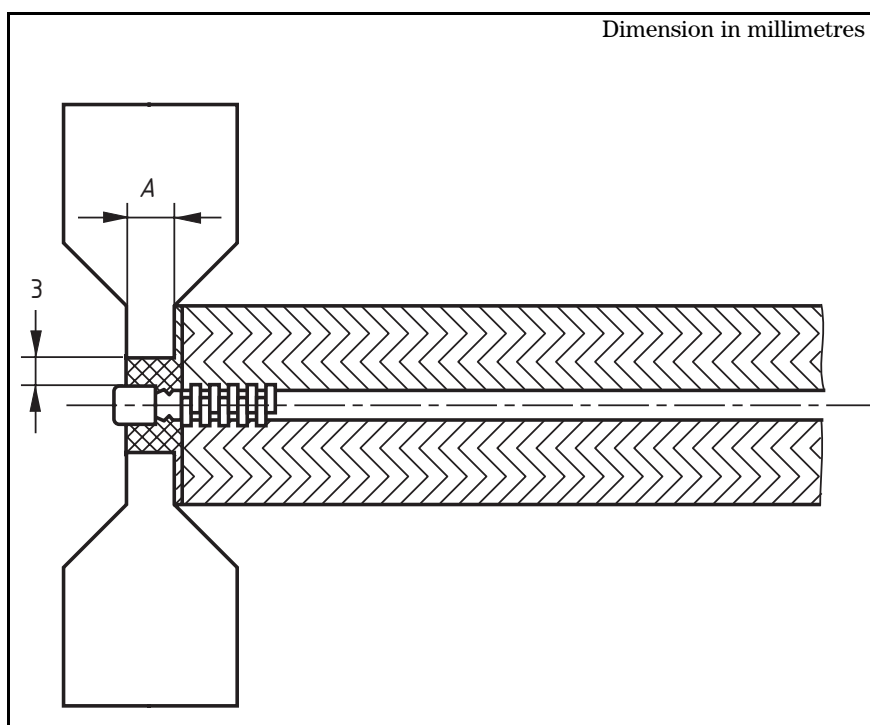

H.3 Procedure

Secure the test specimen in place with the gripping jaws set approximately 3 mm from the side edges of the box, and with one edge of each gripping jaw aligned with the ends of the tapes (as shown in Figure H.1) set the machine in operation until the specified force is reached or the test specimen fails.

Annex I (normative) Test for strength of slider locking device

I.1 Principle

The slider is locked on the chain and the locking device subjected to tension via the chain stringers in such a way as to bring the locking device under pressure from the chain.

I.2 Apparatus

I.2.1 *constant rate of extension tensile testing machine, as described in Annex B (see Figure I.1).*

I.3 Procedure

Mount the test specimen in the open position, with the locking device locked into the chain 25 mm from the top stops. Set the gripping jaws 50 mm apart and secure the top of the stringer into the gripping jaws adjacent to the top stop so that the top of the slider is 25 mm from the edge of each gripping jaw. Set the machine in motion and increase the force until the locking mechanism slips, the specified force is reached or the test specimen fails.

NOTE Instances of failure of the test specimen include slipping of the locking mechanism or damage to an element.

Figure I.1 Slider locking test

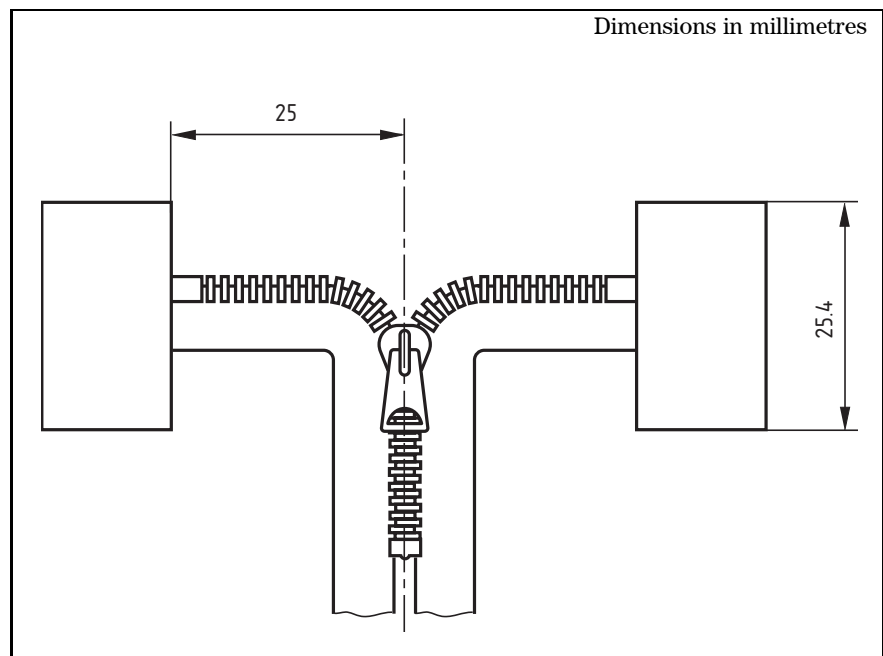

Annex J (normative) Test for open-end fastener single stringer slider retention

J.1 Principle

The single top stop is subjected to a force via the slider applied through the puller.

J.2 Apparatus

J.2.1 *constant rate of extension tensile testing machine, as described in Annex B (see Figure J.1).*

J.3 Procedure

Open the test specimen to provide a single stringer with the slider adjacent to the top stop. Secure the puller in the upper gripping jaw of the testing machine and the other end of the specimen in the lower gripping jaw, steps being taken to avoid damaging the stringer. Set the machine in operation until the specified force is reached or the test specimen fails.

NOTE Instances of failure include the slider becoming detached from the top of the slide fastener and the removal of the puller from the slider body.

Figure J.1 Open-end fastener single stringer slider retention test

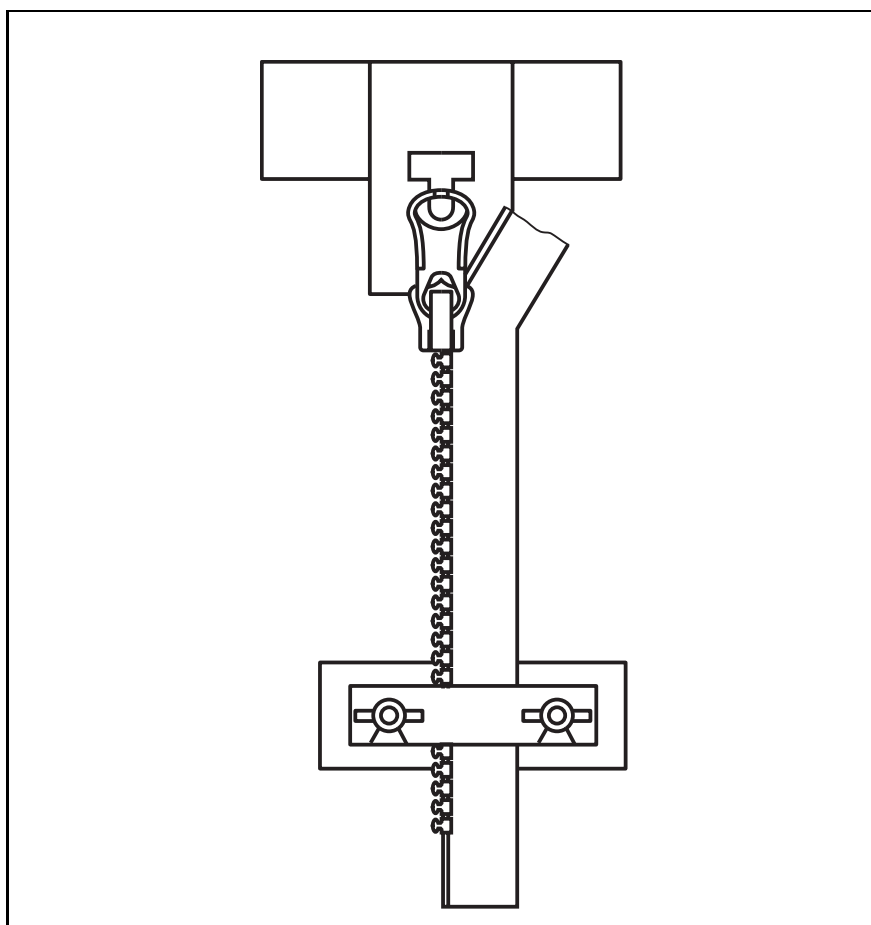

Annex K (informative) Sampling procedures for bulk quantities of fasteners

K.1 General

Batch sizes and test rates should be in accordance with Table K.1. BS 6000 and BS 6001 should be consulted for information on sampling plans, including the switch from normal to tightened procedures.

K.2 Guide to changing from normal to tightened test rate

If two of five or fewer successive batches have been rejected at the normal test rate, then the tightened test rate should be introduced and remain in force until five successive batches have been accepted, after which the normal test rate can be restored.

Table K.1 Batch sizes and test rates

Test rate	Batch size	No. of samples	No. of failures giving rise to:	
			Acceptance of batch	Rejection of batch
Normal	501 to 1 200	13	1	2
	1 201 to 3 200	13	1	2
	3 201 to 10 000	20	2	3
Tightened	501 to 1 200	20	1	2
	1 201 to 3 200	20	1	2
	3 201 to 10 000	20	1	2

Bibliography

BS 6000 (all parts), *Guide to the selection and usage of acceptance sampling systems for inspection of discrete items in lots.*

BS 6001 (all parts), *Sampling procedures for inspection by attributes.*

BS 3F 121, *Specification for metallic slide fasteners for aerospace purposes*

BS EN ISO 7500-1, *Metallic materials – Verification of static uniaxial testing machines – Part 1: Tension/compression testing machines – Verification and calibration of the force-measuring system*

BSI – British Standards Institution

BSI is the independent national body responsible for preparing British Standards. It presents the UK view on standards in Europe and at the international level. It is incorporated by Royal Charter.

Revisions

British Standards are updated by amendment or revision. Users of British Standards should make sure that they possess the latest amendments or editions.

It is the constant aim of BSI to improve the quality of our products and services. We would be grateful if anyone finding an inaccuracy or ambiguity while using this British Standard would inform the Secretary of the technical committee responsible, the identity of which can be found on the inside back cover.

Tel: +44 (0)20 8996 9000. Fax: +44 (0)20 8996 7400.

BSI offers members an individual updating service called PLUS which ensures that subscribers automatically receive the latest editions of standards.

Buying standards

Orders for all BSI, international and foreign standards publications should be addressed to Customer Services. Tel: +44 (0)20 8996 9001.

Fax: +44 (0)20 8996 7001. Email: orders@bsi-global.com. Standards are also available from the BSI website at <http://www.bsi-global.com>.

In response to orders for international standards, it is BSI policy to supply the BSI implementation of those that have been published as British Standards, unless otherwise requested.

Information on standards

BSI provides a wide range of information on national, European and international standards through its Library and its Technical Help to Exporters Service. Various BSI electronic information services are also available which give details on all its products and services. Contact the Information Centre. Tel: +44 (0)20 8996 7111. Fax: +44 (0)20 8996 7048. Email: info@bsi-global.com.

Subscribing members of BSI are kept up to date with standards developments and receive substantial discounts on the purchase price of standards. For details of these and other benefits contact Membership Administration. Tel: +44 (0)20 8996 7002. Fax: +44 (0)20 8996 7001. Email: membership@bsi-global.com.

Information regarding online access to British Standards via British Standards Online can be found at <http://www.bsi-global.com/bsonline>.

Further information about BSI is available on the BSI website at <http://www.bsi-global.com>.

Copyright

Copyright subsists in all BSI publications. BSI also holds the copyright, in the UK, of the publications of the international standardization bodies. Except as permitted under the Copyright, Designs and Patents Act 1988 no extract may be reproduced, stored in a retrieval system or transmitted in any form or by any means – electronic, photocopying, recording or otherwise – without prior written permission from BSI.

This does not preclude the free use, in the course of implementing the standard, of necessary details such as symbols, and size, type or grade designations. If these details are to be used for any other purpose than implementation then the prior written permission of BSI must be obtained.

Details and advice can be obtained from the Copyright & Licensing Manager.

Tel: +44 (0)20 8996 7070. Fax: +44 (0)20 8996 7553.

Email: copyright@bsi-global.com.