



Specification for

Troughed belt conveyors

UDC 621.867.21:001.4:006.3/8

Committees responsible for this British Standard

The preparation of this British Standard was entrusted by the Mechanical Handling Standards Policy Committee (MHE/-) to Technical Committee MHE/9, upon which the following bodies were represented:

AFRC Institute of Engineering Research
 Agricultural Engineers Association
 Amalgamated Union of Engineering Workers
 Associated Offices Technical Committee
 Association of British Mining Equipment Companies
 Association of Consulting Engineers
 British Aggregate Construction Materials Industries
 British Rubber Manufacturers Association
 British Steel Industry
 Coke Oven Managers' Association
 Cranfield Institute of Technology
 Department of Trade and Industry [Mechanical Engineering and Manufacturing Technology Division (Mmt)]
 Electrical, Electronic, Telecommunications and Plumbing Union
 Electricity Supply Industry in England and Wales
 Engineering Equipment and Materials Users Association
 Federation of Wire Rope Manufacturers of Great Britain
 Health and Safety Executive
 Institution of Mechanical Engineers
 Institution of Production Engineers
 Mechanical Handling Engineers Association
 Metal Packaging Manufacturers Association
 Solids Handling and Processing Association

This British Standard, having been prepared under the direction of the Mechanical Handling Standards Policy Committee, was published under the authority of the Board of BSI and comes into effect on 30 June 1989

© BSI 07-1999

First published September 1957
 First revision June 1973
 Second revision June 1989

The following BSI references relate to the work on this standard:
 Committee reference MHE/9
 Draft for comment 84/74257 DC

ISBN 0 580 17177 9

Amendments issued since publication

Amd. No.	Date of issue	Comments
6779	November 1991	Indicated by a sideline in the margin

Contents

	Page
Committees responsible	Inside front cover
Foreword	iii
<hr/>	
1 Scope	1
2 Definitions	1
3 Materials and components of construction	7
4 Belting	8
5 Belt edge clearance	8
6 Pulleys	9
7 Idlers and idler sets	11
8 Transition distances	18
9 Take-up devices	18
10 Power calculations	18
<hr/>	
Appendix A Information to be supplied by the purchaser	19
Appendix B Information to be supplied by the manufacturer, if required	19
Appendix C Capacity and cross section of a conveyor with a smooth patternless belt	20
Appendix D Equation for calculating idler pitch for maximum sag of 2 %	23
Appendix E Pitch of idler sets	23
<hr/>	
Figure 1 — Typical troughed belt conveyor	2
Figure 2 — Typical forms of drive	3
Figure 3 — Typical forms of take-up device	4
Figure 4 — Typical travelling tripper	5
Figure 5 — Typical arrangement of troughed belt shuttle conveyor	6
Figure 6 — Typical plough	6
Figure 7 — Belt edge clearance	8
Figure 8 — Idler dimensions	11
Figure 9 — Plan views of in-line and staggered carrying idler sets	12
Figure 10 — Part view of in-line idler set in vertical plane	12
Figure 11 — Part view of staggered idler set in vertical plane	12
Figure 12 — View in vertical plane showing angle of inclination of wing idlers for troughed carrying idler sets	13
Figure 13 — Side elevation of wing idler with forward tilt	13
Figure 14 — Side elevation of carrying idlers	13
Figure 15 — Single flat return idler	14
Figure 16 — Two return idlers in vee form	14
Figure 17 — Plan view of vee return idler	14
Figure 18 — Clearance between return idler and supporting structure	14
Figure 19 — Nominal idler lengths for three-idler carrying sets, flat and vee return idlers	15
Figure 20 — Mounting dimensions of carrying and return idler sets	17
Figure 21 — Impact ring dimensions	17
Figure 22 — Disc dimensions	18
Figure 23 — Trough section with three carrying idlers	21
Figure 24 — Factor k as a function of slope angle δ	21
<hr/>	

	Page
Table 1 — British Standards for materials and components to be used in the manufacture of troughed belt conveyors	7
Table 2 — Belt width	8
Table 3 — Belt edge clearance	9
Table 4 — Minimum pulley face length	9
Table 5 — Pulley nominal diameters	9
Table 6 — Minimum pulley diameter appropriate to belt construction	10
Table 7 — Nominal outside diameters of carrying and return idlers	11
Table 8 — Nominal lengths of carrying and return idlers	11
Table 9 — Minimum radial clearance for carrying idlers	13
Table 10 — Nominal lengths of carrying and return idlers appropriate to belt widths	15
Table 11 — Mounting dimensions of carrying and return idler sets appropriate to belt width	16
Table 12 — Nominal outside idler diameters and related belt speeds	16
Table 13 — Impact ring for carrying idlers outside diameter	17
Table 14 — Discs for return idlers outside diameter	18
Table 15 — Maximum cross section of the handled material, <i>S</i> , for triple-roller troughed belts in accordance with Figure 23 with equal-length carrying idlers	22
Table 16 — Typical pitch of idler sets with troughing angle up to 35°	23
Publications referred to	25

Foreword

This British Standard has been prepared under the direction of the Mechanical Handling Standards Policy Committee. It is a revision of BS 2890:1973, which is withdrawn. More detailed requirements for pulley and idler lengths have been specified in this edition of the standard. The relationship between the dimensions specified in this British Standard and those specified in the relevant standards published by the International Organization for Standardization (ISO) is also given.

The requirements and guidance given in the previous edition on statutory requirements and guarding have not been included in this standard. They will be incorporated into a future code of practice for the safeguarding of hazard points on troughed belt conveyors.

This standard applies to the mechanical parts of troughed belt conveyors on which belts complying with BS 490-1 are used. If other types of conveyor belting are used, those requirements in the standard which relate to belt tensions, pulley diameters and take-up allowance may not be applicable. Requirements for the design of the supporting structure are not specified.

Requirements in this standard are based on dry conditions of operation and the manufacturer should be consulted regarding applications intended for wet conditions.

This standard is a companion standard to BS 4531 "*Portable and mobile troughed belt conveyors*".

A British Standard does not purport to include all the necessary provisions of a contract. Users of British Standards are responsible for their correct application.

Compliance with a British Standard does not of itself confer immunity from legal obligations.

Summary of pages

This document comprises a front cover, an inside front cover, pages i to iv, pages 1 to 26, an inside back cover and a back cover.

This standard has been updated (see copyright date) and may have had amendments incorporated. This will be indicated in the amendment table on the inside front cover.

1 Scope

This British Standard specifies the design and dimensional requirements for non-mobile troughed belt conveyors and their components.

It applies to conveyors fitted with rubber or plastics belting with textile reinforcement complying with BS 490-1 carrying loose bulk materials and with a maximum belt speed of 5 m/s.

This standard does not apply to the following categories but can be used as a guidance document for them:

- a) underground mine conveyors;
- b) conveyors handling materials that do not behave as solids;
- c) conveyors fitted with steel cord belting.

NOTE 1 Appendix A provides guidance on the information to be supplied by the purchaser when ordering. Appendix B provides guidance on the information to be supplied by the manufacturer.

NOTE 2 Portable and mobile conveyors are covered in BS 4531.

NOTE 3 The titles of the publications referred to in this standard are listed on pages 25, 26 and 27.

2 Definitions

For the purposes of this British Standard, the following definitions apply.

NOTE Typical forms of conveyors and their components are shown in Figure 1 to Figure 6.

2.1

head of the conveyor

the discharge end of the conveyor

2.2

tail of the conveyor

the loading end of the conveyor

2.3

carrying idler

an idler which supports the loaded belt. An assembly of one or more free-running carrying idlers comprises a carrying idler set

2.4

return idler

an idler which supports the empty side of the belt. An assembly of one or more idlers comprises a return idler set

2.5

take-up device

the device for taking up slack and applying tension to the belt

NOTE Typical forms of take-up device are shown in Figure 3.

2.6

anti-run-back device

an automatic device for preventing a loaded elevating conveyor running backward when the power source is removed

2.7

driving pulley

the pulley that drives the belt

2.8

snub pulley

the pulley used to develop the necessary arc of contact (angle of wrap) of the belt on the driving pulley

2.9

bend pulley

the pulley used to change the direction of the belt

2.10

head pulley

the terminal pulley at the head of a conveyor

NOTE This may be a driving pulley.

2.11

tail pulley

the terminal pulley at the tail of a conveyor

NOTE This may be a take-up pulley.

2.12

take-up pulley

the travelling pulley used in the take-up device

2.13

drive

the equipment which drives the belt, consisting of a power unit, transmission and driving pulley

NOTE Typical forms of drive are shown in Figure 2.

2.14

power unit

the conveyor power source

NOTE Examples of power units are an electric motor, internal combustion engine, motorized pulley.

2.15

transmission

the assembly of devices coupling the power unit to the driving pulley for driving the belt at the desired speed

2.16

handing of conveyor

the designation of the sides of a unidirectional conveyor e.g. left or right when viewed from the tail to the head of the conveyor

**2.17
brake**

a device for bringing the belting of a conveyor to rest and maintaining it at rest

**2.18
chute**

a straight or curved, open-topped or enclosed, smooth trough by which materials are directed and lowered by gravity

**2.19
safeguard**

a guard or device designed to protect persons from danger

**2.20
regenerative conveyor**

a conveyor for which the head is substantially lower than the tail, giving a negative power requirement

**2.21
retarder**

a device for preventing the overspeeding of a regenerative conveyor

**2.22
cleaner**

a device for removing adherent material from the belt or a pulley

**2.23
overend discharge**

discharge over the head of the conveyor

**2.24
tripper**

a device mounted either in a fixed position or on a travelling carriage, for discharging material from a belt conveyor at selected points or at any point along the length

NOTE A typical travelling tripper is shown in Figure 4.

**2.25
shuttle conveyor**

a unidirectional or reversible belt conveyor having overend discharge, the whole being mounted on a travelling carriage capable of being shuttled backwards and forwards along a track, giving a continuous distributed discharge

NOTE A typical arrangement of a troughed belt shuttle conveyor is shown in Figure 5.

**2.26
plough**

a blade or blades mounted obliquely across the belt to discharge the material by deflecting it from the belt

NOTE 1 This can be useful where headroom and space are limited but it is not recommended for any duty other than slow speed conveyors handling non-abrasive free-flowing materials.
NOTE 2 A typical plough is shown in Figure 6.

Licensed Copy: Gautam Sinharoy, Bechtel Ltd, 02 December 2003, Uncontrolled Copy, (c) BSI

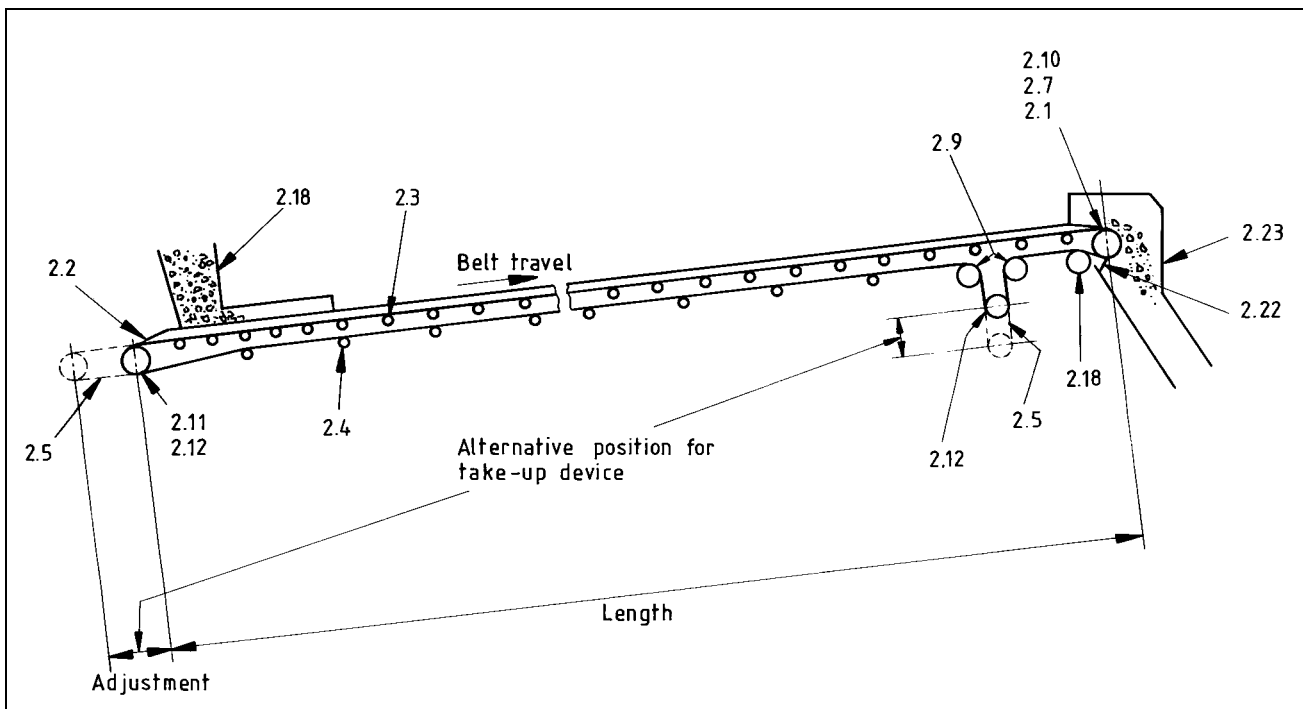
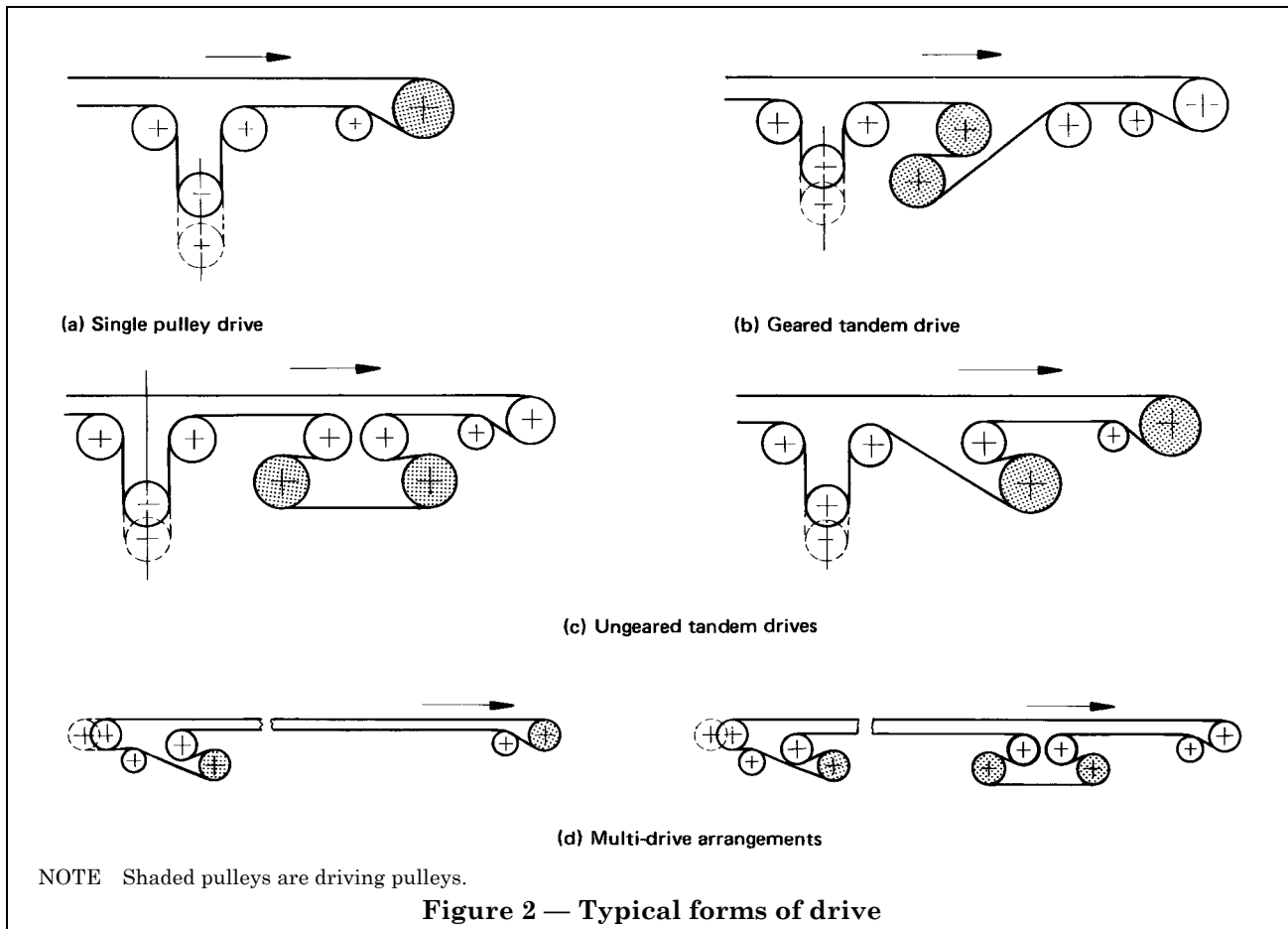
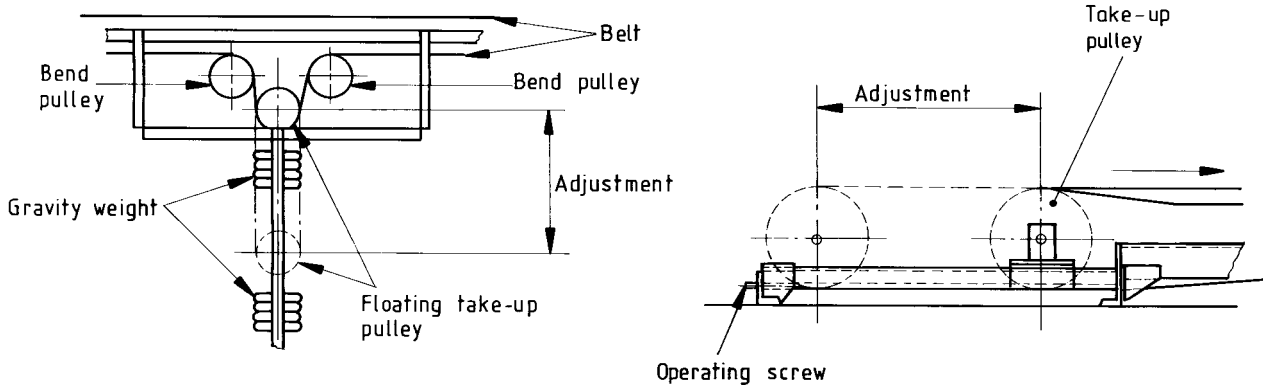
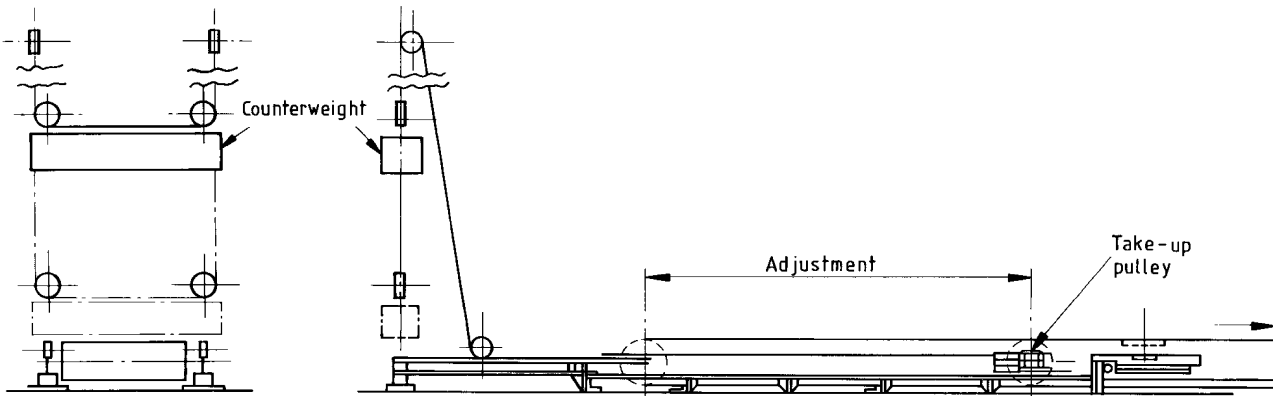

Figure 1 — Typical troughed belt conveyor





(a) Gravity-weight-operated, vertical take-up at intermediate point of conveyor (b) Screw-operated take-up at tail end of conveyor



(c) Gravity-weight-operated take-up at tail end of conveyor

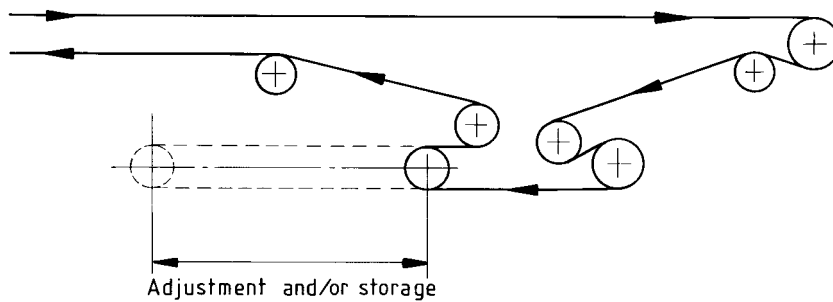

NOTE Take-up is by hydraulic, electric, gravity weight or mechanical method.
 (d) Loop take-up

Figure 3 — Typical forms of take-up device

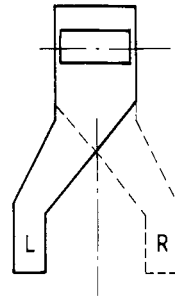
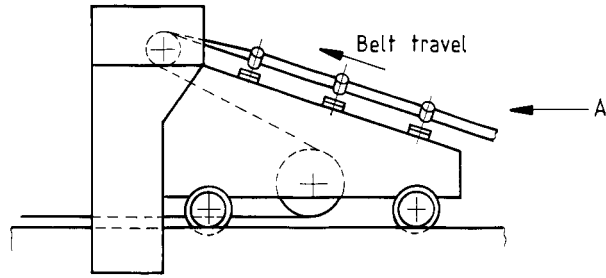

One-way chute for one side discharge, either right or left

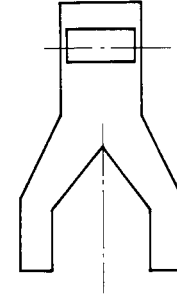

Two-way chute for discharge to both sides simultaneously

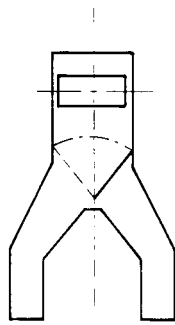

Two-way chute with flap valve for discharge to either side alternately or to both sides simultaneously

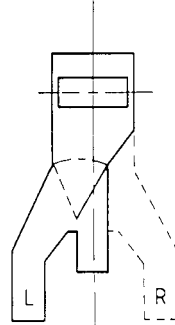

Two-way chute with flap valve for discharge to one side R or L hand or alternatively forward

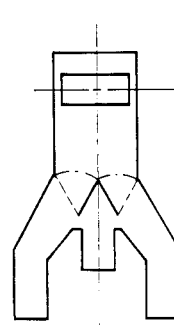

Three-way chute with flap valve for discharge to both sides simultaneously or alternatively forward

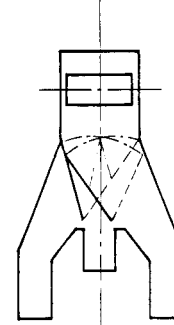

Three-way chute with two flap valves for discharge to either side alternately, both sides simultaneously or alternatively forward

NOTE Chutes are viewed in the direction of arrow A.

Figure 4 — Typical travelling tripper

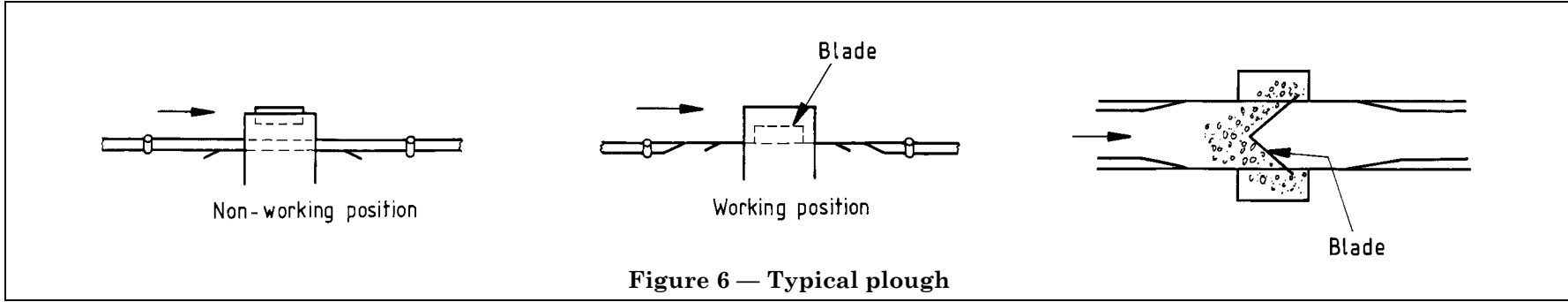
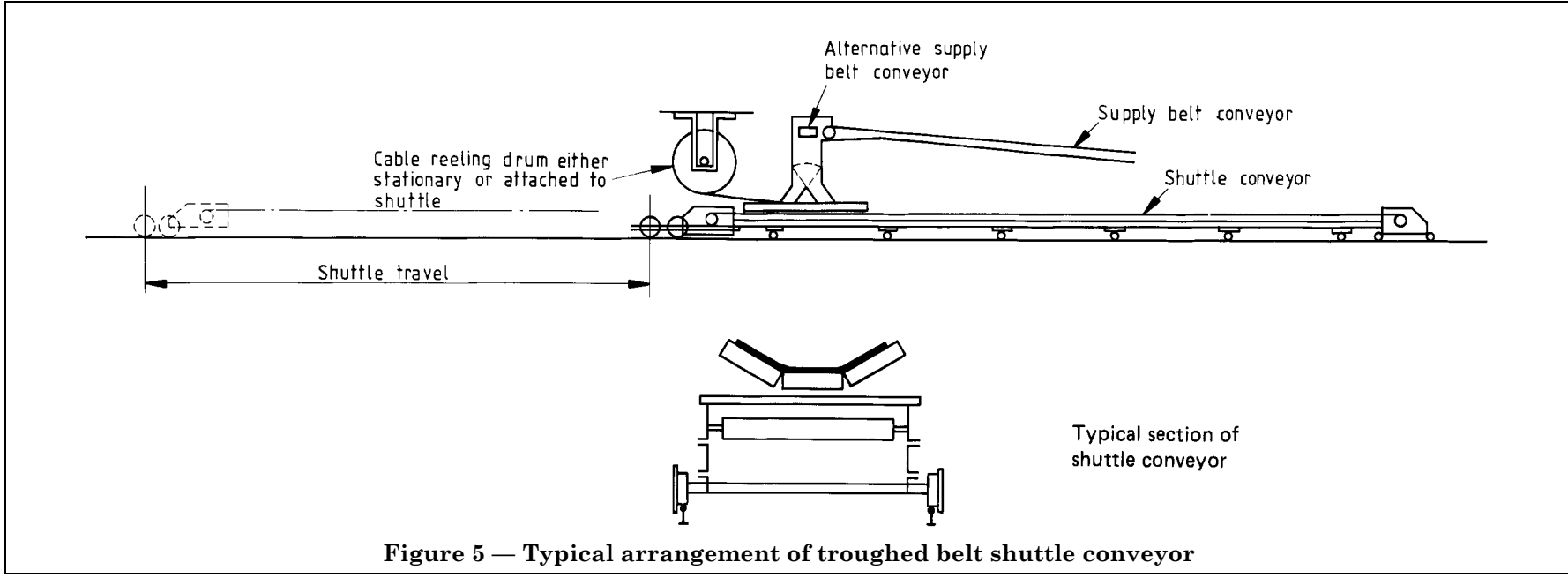

3 Materials and components of construction

Materials and components used in the construction of conveyors shall comply with the appropriate British Standards listed in Table 1.

Table 1 — British Standards for materials and components to be used in the manufacture of troughed belt conveyors

Material/component	British Standard	Material/component	British Standard
Ball and roller bearings	BS 292-1 and BS 292-2 BS 3134-1 to BS 3134-3	Rivets: a) aluminium and alloy b) dimensions	BS 1473 BS 275
Bars, rods and sections, aluminium alloy	BS 1474	Screw threads and fasteners	BS 856 BS 3643-1 and BS 3643-2 BS 3692 BS 4183 BS 4190 BS 4219-1 to BS 4219-4 BS 4320 BS 4395-1 BS 4439 BS 4463 BS 4464
Castings: a) malleable b) copper alloy and ingots c) grey iron d) steel e) die castings, zinc and zinc alloys	BS 6681 BS 1400 BS 1452 BS 3100 BS 1004		
Chains and chain wheels	BS 228	Sections: steel	BS 4848-4
Conveyor belting	BS 490-1	Splines and serrations	BS 2059
Forging and forging stock, aluminium and alloy	BS 1472	Springs: helical and volute	BS 24-3B
Keys and keyways	BS 46-1 BS 4235-1	Steel: a) structural b) wrought	BS 4360 BS 970-1
Limits and fits	BS 4500-1 and BS 4500-3	Timber: stress graded	BS 4978
Lubricating nipples and adaptors	BS 1486-1 and BS 1486-2	Tubes: a) aluminium and alloy b) steel	BS 1471 BS 1474 BS 6323-1 to BS 6323-8
Motors and generators	BS 5000-99	V-belt drives	BS 3790
Plate sheet and strip: a) aluminium and alloy b) steel	BS 1470 BS 1449-1 and BS 1449-2	Welding	BS 5135
preferred numbers and preferred sizes	PD 6481	Wire ropes	BS 302-1 and BS 302-2
Rigging screws and stretching screws	BS 4429	Wire: mild steel	BS 1052
		Wrought aluminium	BS 1475

4 Belting

4.1 Belt width

Belt widths shall be selected from the values given in Table 2.

Table 2 — Belt width

mm
400 ^a
500 ^a
600 ^a
650 ^a
750
800 ^a
900
1 000 ^a
1 050
1 200 ^a
1 350
1 400 ^a
1 600 ^a
1 800 ^a
2 000 ^a

^a These values are identical with those specified in BS 490-1:1985 and ISO 251:1987.

4.2 Belt capacity and speed

The maximum belt speed shall not exceed 5 m/s.

Belt width and speed shall be chosen to ensure that the load on the conveyor is within the nominal cross-sectional capacity calculated in accordance with Appendix C and that the conveyor operates without spillage.

NOTE Belt width and speed should be chosen to suit the particular application with due regard to the nature, size grading, characteristics and angle of repose of the material to be handled.

5 Belt edge clearance

The minimum clearance between the edge of the belt and the conveyor structure when determined as shown in Figure 7 shall be in accordance with Table 3.

NOTE 1 This requirement should also apply to surrounding structures when the conveyor is installed.

NOTE 2 Use of edge idlers should be avoided if possible and, to minimize damage to the belt, the conveyor structure should present smooth surfaces in the line of belt travel.

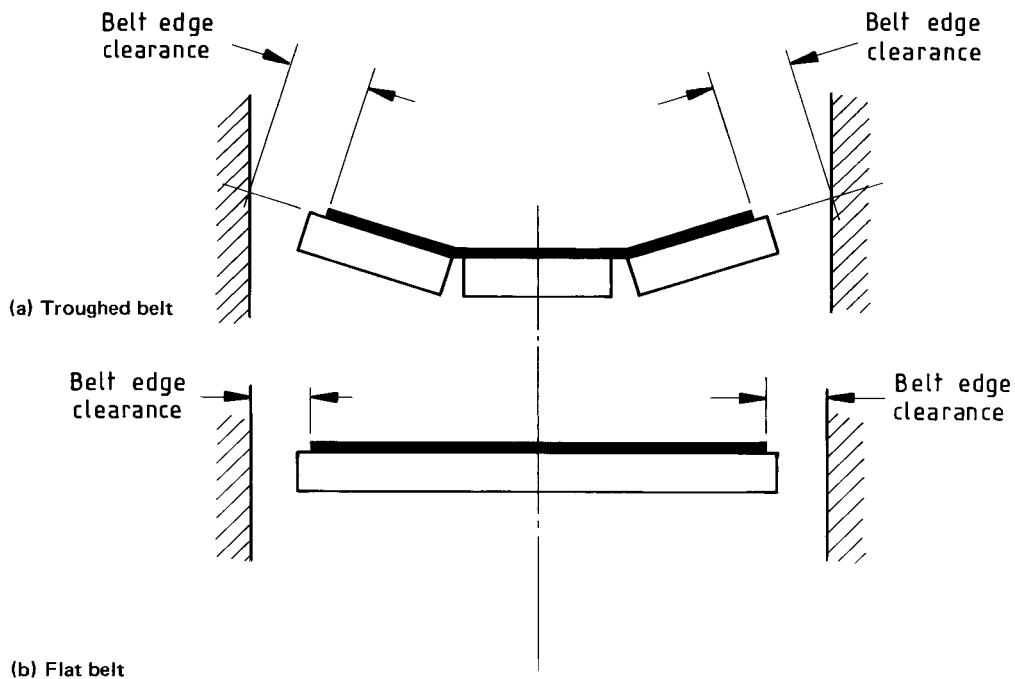

Figure 7 — Belt edge clearance

Table 3 — Belt edge clearance

Belt width	Minimum clearance
mm	mm
400 ^a	50
500 ^a	
600	
650 ^a	
750	75
800 ^a	
900	
1 000 ^a	
1 050	
1 200 ^a	
1 350	100
1 400 ^a	
1 600 ^a	
1 800 ^a	
2 000 ^a	

^a The clearances for these values are identical with those specified in ISO 1535:1975.

Table 4 — Minimum pulley face length

Belt width	Minimum pulley face length
mm	mm
400	500 ^{ab}
500	600 ^{ab}
600	700
650	750 ^{ab}
750	900
800	950 ^{ab}
900	1 050
1 000	1 150 ^{ab}
1 050	1 200
1 200	1 350
1 350	1 500
1 400	1 550
1 600	1 800 ^a
1 800	2 000 ^a
2 000	2 200 ^a

^a These values are identical with those specified in ISO 1536:1975.
^b These values are identical with those specified in ISO 1816:1975.

6 Pulleys

6.1 Minimum pulley face length

The minimum pulley face length shall be as given in Table 4.

6.2 Pulley nominal diameter

The pulley nominal diameter (which includes any pulley lagging) shall be selected from those given in Table 5, subject to 6.4.

NOTE 1 The nominal diameter of a crowned pulley is the maximum diameter.

NOTE 2 Special attention may have to be given to the accuracy of pulley diameters when pulleys are used as matched pairs within a tandem pulley drive.

6.3 Profile

The pulley surface in contact with the belt shall have a flat or crowned profile. When crowned, the shape of the profile shall be regular and symmetrical. A flat central part shall not exceed 40 % of the width of the pulley. The transition between a flat central part and sloping parts of a crowned pulley shall be blended.

The pulley nominal diameter shall not exceed the edge diameter by more than 1 %.

NOTE The use of a flat or crowned pulley depends upon the conveyor application. Crowning may assist in centralizing the running of the conveyor belt but it should not be applied to close coupled, multi-drive or snub pulleys.

Table 5 — Pulley nominal diameters

mm
200 ^{ab}
250 ^{ab}
315 ^{ab}
355
400 ^{ab}
455
500 ^{ab}
610
630 ^{ab}
760
800 ^{ab}
915
1 000 ^a
1 060
1 220
1 250 ^a
1 370
1 400 ^a
1 600 ^a

^a These values are identical with those specified in ISO 1536:1975.
^b These values are identical with those specified in ISO 1816:1975.

Table 6 — Minimum pulley diameter appropriate to belt construction

Anticipated maximum belt tension	Manufacturer's nominal belt carcass thickness																							
	Up to 3 mm			Above 3 mm and up to 4 mm			Above 4 mm and up to 5 mm			Above 5 mm and up to 6.5 mm			Above 6.5 mm and up to 8 mm			Above 8 mm and up to 10 mm			Above 10 mm and up to 12.5 mm			Above 12.5 mm and up to 16 mm		
	Minimum pulley diameter																							
	A ^a	B ^b	C ^c	A	B	C	A	B	C	A	B	C	A	B	C	A	B	C	A	B	C	A	B	C
kN per metre of belt width	mm	mm	mm	mm	mm	mm	mm	mm	mm	mm	mm	mm	mm	mm	mm	mm	mm	mm	mm	mm	mm	mm	mm	mm
10	200	200	200	250	200	200	250	200	200	—	—	—	—	—	—	—	—	—	—	—	—	—	—	—
12.5	200	200	200	250	200	200	250	250	200	—	—	—	—	—	—	—	—	—	—	—	—	—	—	—
16	200	200	200	250	250	200	315	250	200	315	250	250	—	—	—	—	—	—	—	—	—	—	—	—
20	250	200	200	315	250	200	315	250	250	315	315	250	400	315	315	—	—	—	—	—	—	—	—	—
25	250	250	200	315	250	250	315	315	250	400	315	250	400	400	315	500	400	400	—	—	—	—	—	—
32	315	250	200	315	315	250	400	315	250	400	315	315	500	400	315	500	500	400	630	500	500	—	—	—
40	315	315	250	400	315	250	400	315	315	400	400	315	500	400	400	630	500	400	630	630	500	800	630	630
50	400	315	250	400	315	315	400	400	315	500	400	315	500	500	400	630	500	500	630	500	500	800	630	500
63	—	—	—	400	400	315	500	400	315	500	400	400	630	500	400	630	630	500	630	630	500	800	630	630
80	—	—	—	—	—	—	500	400	400	500	500	400	630	500	500	800	630	500	800	630	500	800	800	630
100	—	—	—	—	—	—	—	—	—	630	500	400	630	630	500	800	630	630	1 000	800	630	1 000	1 000	800
125	—	—	—	—	—	—	—	—	—	630	630	500	800	630	500	800	800	630	1 000	800	800	1 250	1 000	800
160	—	—	—	—	—	—	—	—	—	—	—	—	800	630	630	1 000	800	800	1 000	1 000	800	1 250	1 000	1 000
200	—	—	—	—	—	—	—	—	—	—	—	—	—	—	—	1 000	1 000	800	1 250	1 000	1 000	1 250	1 250	1 000

^a A = Driving pulleys.
^b B = Non-driving pulleys (terminal, tripper, take-up, snub and bend pulleys) located where the belt tension may exceed 60 % of the anticipated maximum belt tension.
^c C = Non-driving pulleys (terminal, take-up, snub and bend pulleys) located where the belt tension will not exceed 60 % of the anticipated maximum belt tension.

6.4 Minimum pulley diameter appropriate to nominal belt carcass thickness

The minimum pulley diameter shall be as given in Table 6 for the appropriate belt carcass thickness and recommended maximum belt tension (RMBT) or anticipated maximum belt tension, if this is lower than the RMBT.

NOTE 1 The anticipated maximum belt tension should not exceed the RMBT as stated by the belting manufacturer.

NOTE 2 Use of driving pulleys of larger diameter than those shown in Table 6 will not permit employment of a maximum belt tension in excess of the RMBT.

NOTE 3 Use of pulleys having diameters which are too small for the belt carcass thickness may lead to premature failure of the belt.

NOTE 4 The diameters given in Table 6 are the minimum values considered necessary to ensure satisfactory belt life, but care should be taken to provide driving pulleys of sufficient diameter to ensure adequate traction.

7 Idlers and idler sets

7.1 General

Idler sets shall be of fixed configuration. Idler rollers shall be of the secured or drop-in type.

NOTE Special idlers may be necessary for impact absorption at loading points or to cater for dirty conditions on the return strand, e.g. rubber covered or disc types.

7.2 Materials

Idler sets shall be of electric resistance or induction welded (ERW) steel tube complying with BS 6323-5 or cast iron complying with the requirements for grade 180 of BS 1452¹⁾.

7.3 Nominal outside diameters of idlers

The nominal outside diameters of carrying and return idlers (D in Figure 8) shall be selected from the values given in Table 7.

Table 7 — Nominal outside diameters of carrying and return idlers

mm
101.6
108
127
133
152.4
159
168.3

NOTE These diameters are identical with those given in BS 6323-5:1982 and ISO 1537:1975.

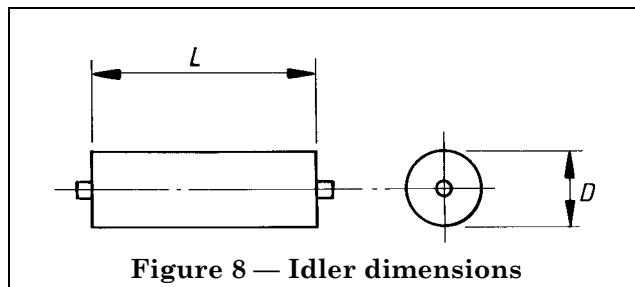

Figure 8 — Idler dimensions

7.4 Nominal idler lengths

The nominal lengths of carrying and return idlers (L in Figure 8) shall be selected from the values given in Table 8 and in accordance with the appropriate belt width as specified in 7.7.

Table 8 — Nominal lengths of carrying and return idlers

Carrying idlers mm	Return idlers mm
160 ^a	465 ^a
200 ^a	500 ^a
240	530
250 ^a	600 ^a
295	670 ^a
315 ^a	700
350	750 ^a
380 ^a	800 ^a
410	900 ^a
465 ^a	950 ^a
530	1 000 ^a
600 ^a	1 050
670 ^a	1 150 ^a
750 ^a	1 200
	1 350
	1 500
	1 600 ^a
	1 800 ^a
	2 000 ^a
	2 200 ^a

^a These values are identical with those specified in ISO 1537:1975.

7.5 Arrangement of carrying idler sets

7.5.1 In-line and staggered idler sets

7.5.1.1 General. A troughed carrying idler set shall be arranged with the idlers in-line or staggered in the plane of the belt as shown in Figure 9.

¹⁾ Under revision

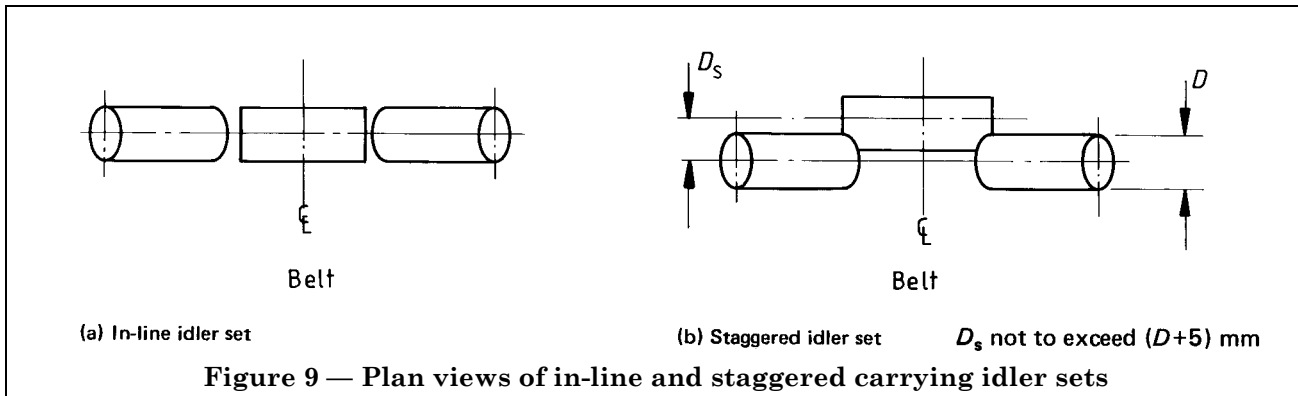

7.5.1.2 In-line idler sets. The gap between the adjacent ends of the idlers shall be not greater than 10 mm when measured as shown in Figure 10.

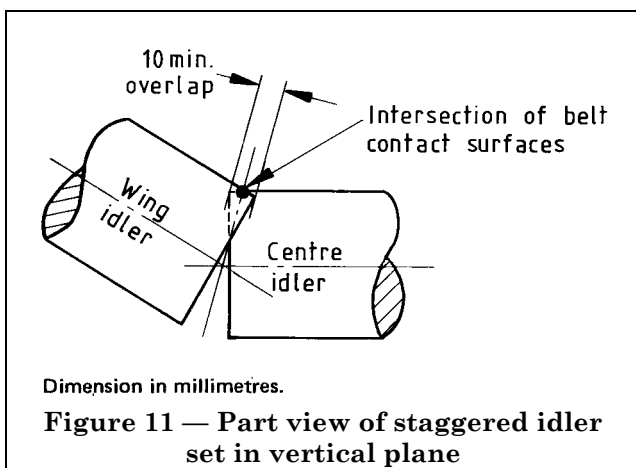
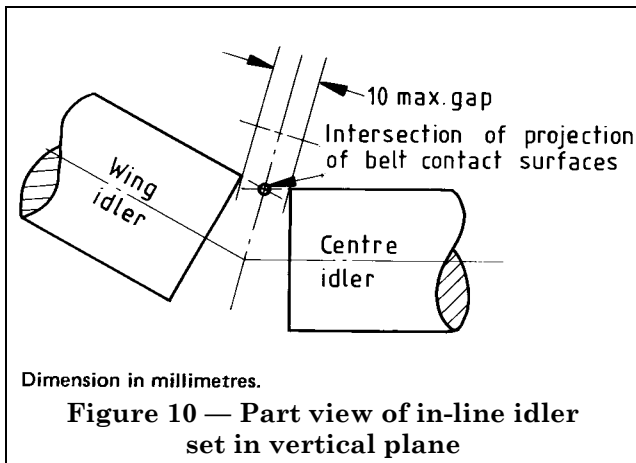

7.5.1.3 Staggered idler sets. In plan view, the displacement of the axis of an idler from the axis of the adjacent idler (D_s) shall not exceed the nominal diameter of the idlers plus 5 mm [$(D + 5)$ mm] as shown in Figure 9. The idler set shall be arranged with adjacent ends of idlers overlapping by a minimum of 10 mm when measured as shown in Figure 11.

7.5.2 Troughing angle. The angle of inclination of wing idlers (the troughing angle, angle α in Figure 12) in 3-idler sets for both in-line and staggered idler sets shall be 20°, 25°, 30°, 35°, 40° or 45° for troughed section of the conveyor when measured in the plane shown in Figure 12.

NOTE Idler sets having troughing angles other than those specified may be necessary for the transition between flat and troughed sections of a conveyor adjacent to the terminal pulleys.

7.5.3 Forward tilt. When wing idlers are required to be tilted forward in the direction of belt travel to assist training, the angle of tilt (angle β in Figure 13) shall not exceed 3°, measured relative to the transverse vertical plane as shown in Figure 13. Idler sets having forward tilt shall be clearly and permanently marked with an arrow indicating the direction of belt travel. Idler sets with forward tilt shall not be used on reversible conveyors.

NOTE The angle of tilt should be the minimum commensurate with the particular applications.

7.5.4 Clearance between carrying idler and supporting structure. The minimum radial clearance between the carrying idler shell and its mounting transom or framework when measured as shown in Figure 14 shall be as given in Table 9.

7.6 Arrangement of return idler sets

7.6.1 Flat and vee return idler sets. Return idler sets shall comprise a single flat return idler as shown in Figure 15 or two return idlers in vee form as shown in Figure 16.

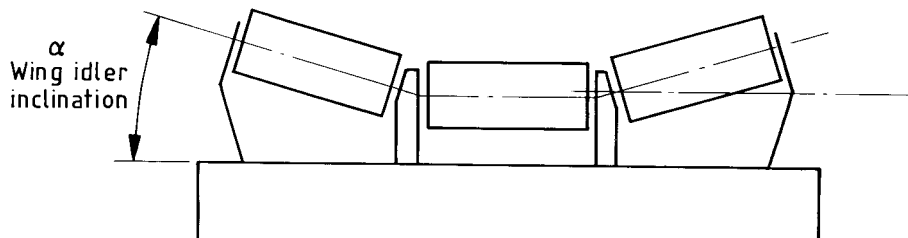

Figure 12 — View in vertical plane showing angle of inclination of wing idlers for troughed carrying idler sets

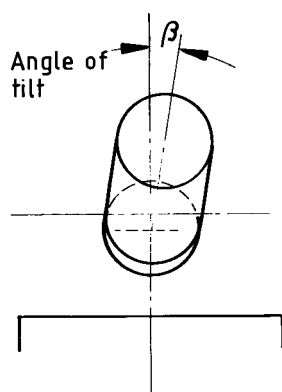

Figure 13 — Side elevation of wing idler with forward tilt

The return idlers in vee return sets shall have an angle of inclination of 10° when measured in the vertical plane as shown in Figure 16, and the gap between adjacent ends of the idlers shall not exceed 25 mm.

NOTE Special return idlers, e.g. rubber covered or disc type, may be used for abrasive or dirty conditions.

Table 9 — Minimum radial clearance for carrying idlers

Idler diameter	Minimum clearance
mm	mm
101.6	30
108.0	
127.0	
133.0	
152.4	40
159.0	
168.3	

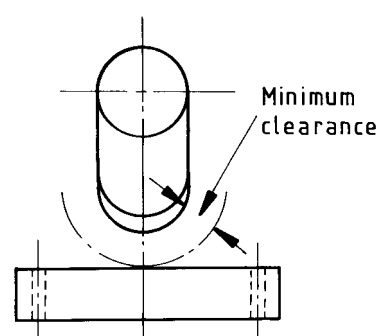

Figure 14 — Side elevation of carrying idlers

7.6.2 Forward tilt. When vee return idlers are required to be tilted forward in the direction of belt travel to assist belt training, the angle of tilt shall not exceed 1° measured in the plane of belt travel as shown in Figure 17. Where the vee return idlers are carried in a supporting transom, the transom shall be clearly and permanently marked with an arrow indicating the direction of belt travel.

NOTE The angle of tilt should be the minimum commensurate with the particular application.

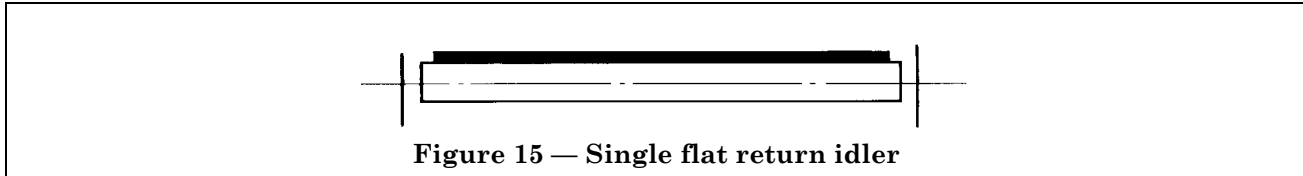

Figure 15 — Single flat return idler

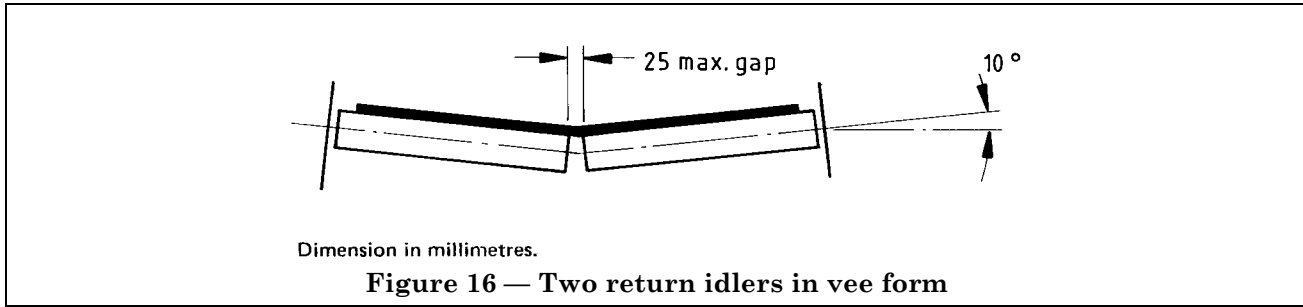
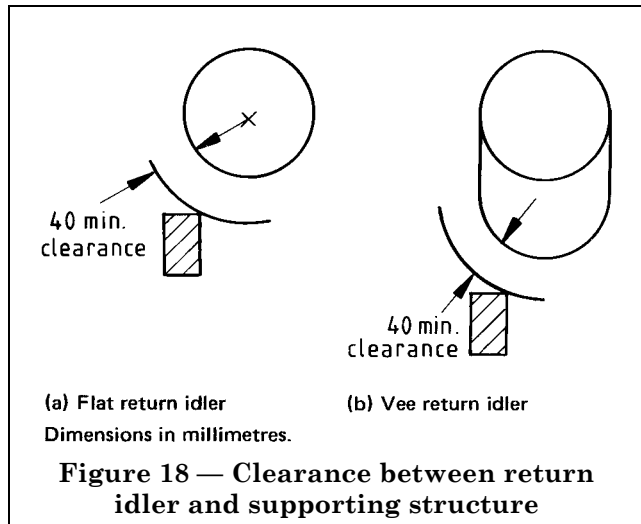

Figure 16 — Two return idlers in vee form

7.6.3 Clearance between return idler and supporting structure. The minimum radial clearance between the return idler shell and any supporting member when measured as shown in Figure 18 shall be 40 mm.

7.7 Nominal idler lengths for three-idler carrying sets, flat and vee return idlers

The nominal lengths of carrying and return idlers for three-idler carrying sets, flat and vee return idlers appropriate to belt width shall be as shown in Figure 19 and as given in Table 10.



(a) Flat return idler (b) Vee return idler

Dimensions in millimetres.

Figure 18 — Clearance between return idler and supporting structure

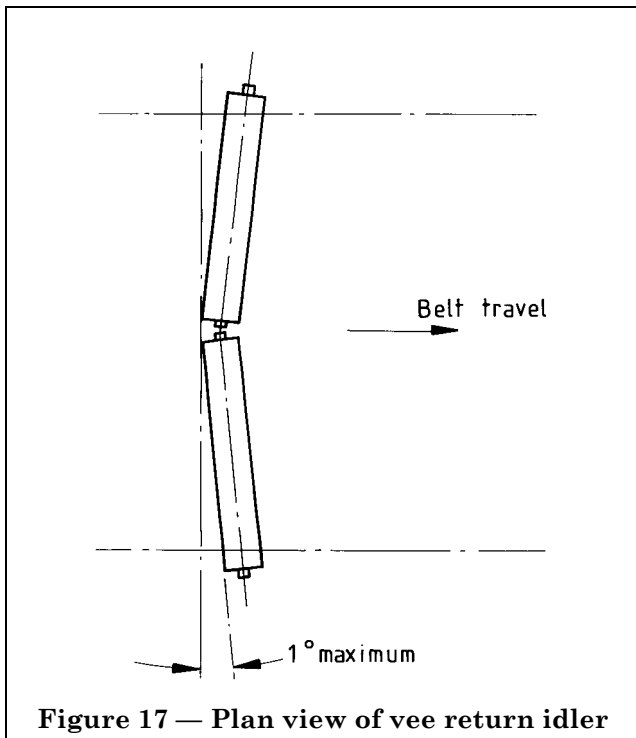

Figure 17 — Plan view of vee return idler

7.8 Mounting dimensions

The mounting dimensions of carrying and return idler sets shall be as shown in Figure 20 and as given in Table 11.

7.9 Design load

The design load for a carrying idler set shall be based on the full cross-sectional capacity of the conveyor belt (see Appendix C), having due regard to the belt troughing angle, surcharge and density of the material as handled together with the mass of the belt, the pitch of the idler sets and the belt tension vertical component acting on the idler set. The design load shall also take into account the dynamic forces.

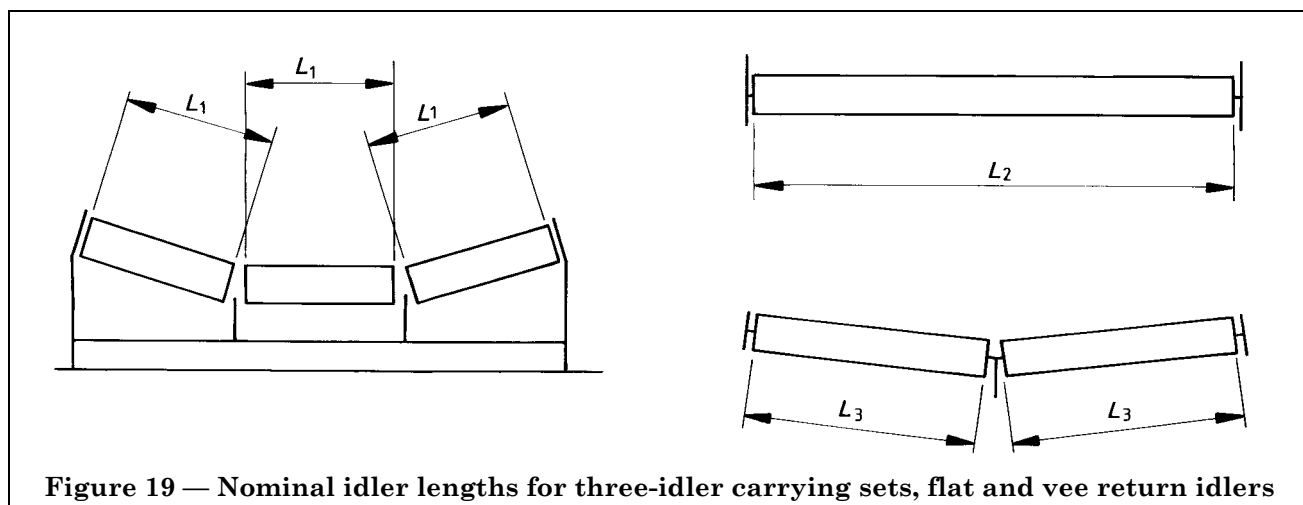

Figure 19 — Nominal idler lengths for three-idler carrying sets, flat and vee return idlers

7.10 Idler bearings

The minimum design rated life for the idler bearings shall be 25 000 h. The manufacturer shall state the basis of his selection of bearings and the rated life of the idler bearings selected.

NOTE The purchaser should provide the manufacturer with the information necessary for determining the required type and size of bearing for the application.

For the purpose of bearing selection for a three-idler set, two-thirds of the load per carrying idler set shall be considered as acting vertically upon the centre idler.

Table 10 — Nominal lengths of carrying and return idlers appropriate to belt width

Belt Width	Nominal length of idler (see Figure 19)		
	L_1	L_2	L_3
mm	mm	mm	mm
400	160 ^a	500 ^{ab}	—
500	200 ^{ab}	600 ^{ab}	—
600	240	700	—
650	250 ^{ab}	750 ^{ab}	—
750	295	900	—
800	315 ^{ab}	950 ^{ab}	465 ^{ab}
900	350	1 050	530
1 000	380 ^{ab}	1 150 ^{ab}	600 ^{ab}
1 050	410	1 200	600
1 200	465 ^a	1 350	670 ^a
1 350	530	1 500	750
1 400	530 ^a	1 600 ^a	800 ^a
1 600	600 ^a	1 800 ^a	900 ^a
1 800	670 ^a	2 000 ^a	1 000 ^a
2 000	750 ^a	2 200 ^a	1 100 ^a

NOTE Carrying idler lengths L_1 apply to both in-line and staggered idler sets.

^a These values are identical with those specified in ISO 1537:1975.

^b These values are identical with those specified in ISO 2109:1975.

The bearings selected for the centre roller shall also be used in the wing idlers provided that they are capable of carrying the axial loading of the wing idlers.

Where ball or rolling bearings are used, the design rated life shall be the L_{10} life calculated in accordance with BS 5512-1.

7.11 Belt speed and eccentricity appropriate to nominal idler outside diameter

NOTE 1 Idlers should be suitable for operation at the speeds given in Table 11.

Eccentricity of the idler outside diameter, measured by a dial test indicator at any point along its length when rotated on its own bearings, shall not exceed the values of full indicated movement (FIM) of 1.5 mm for idler lengths up to 1 350 mm and 2 mm for idler lengths of 1 350 mm and of over 1 350 mm.

NOTE 2 These values are designed to minimize out of balance forces.

7.12 Pitch of idler sets

NOTE 1 The pitch of idler sets along the conveyor depends on factors such as belt tension, load being carried and transverse stiffness of the belt.

Table 11 — Mounting dimensions of carrying and return idler sets appropriate to belt width

Belt width	Height H for nominal outside idler diameter D							Lateral fixing slot pitch L_4	Longitudinal fixing slot pitch C
	$D = 101.6$ mm	$D = 108.0$ mm	$D = 127.0$ mm	$D = 133.0$ mm	$D = 152.4$ mm	$D = 159.0$ mm	$D = 168.3$ mm		
mm	mm	mm	mm	mm	mm	mm	mm	mm	mm
400	200	200	225	225	—	—	—	640	75
500	200	200	225	225	—	—	—	740	75
600	200	200	225	225	275	275	290	840	75
650	200	200	225	225	275	275	290	890	75
750	200	200	225	225	275	275	290	990	75
800	200	200	225	225	275	275	290	1 040	75
900	200	200	225	225	275	275	290	1 140	75
1 000	200	200	225	225	275	275	290	1 240	75
1 050	200	200	225	225	275	275	290	1 300	75
1 200	215	215	240	240	275	275	290	1 450	100
1 350	215	215	240	240	275	275	290	1 650	100
1 400	215	215	240	240	275	275	290	1 700	100
1 600	—	—	240	240	275	275	290	1 900	100
1 800	—	—	240	240	275	275	290	2 100	100
2 000	—	—	240	240	275	275	290	2 300	100

The pitch of carrying idler sets along the conveyor shall be such that the sag of the conveyor belting between adjacent carrying idler sets does not exceed 2 % of the pitch of the idler sets when carrying a full cross-sectional load.

The pitch of return idler sets shall not exceed 6 m.

NOTE 2 An equation for calculating the idler pitch for a maximum sag of 2 % is given in Appendix D.

NOTE 3 In general practice, conveyors arranged with the pitch of idler sets with troughing angle up to 35° as indicated in Appendix E will be found suitable.

NOTE 4 At loading points, where considerable impact may occur, carrying idlers should be spaced more closely.

7.13 Impact rings and discs

7.13.1 General. Impact rings and discs shall be manufactured from an elastic material, e.g. rubber.

7.13.2 Impact rings for carrying idlers. The nominal outside diameter of impact rings for carrying idlers (D_2 in Figure 21) for the associated roller tube diameter (D_1 in Figure 21) shall be in accordance with Table 13. The bore of the impact ring shall have an interference fit on the roller tube. The form of the impact ring shall be at the discretion of the manufacturer.

Table 12 — Nominal outside idler diameters and related belt speeds

Nominal outside diameter for carrying and return idlers		Maximum belt speed
mm		m/s
101.6	}	3.0
108.0		
127.0	}	3.75
133.0		
152.4	}	5.0
159.0		
168.3		

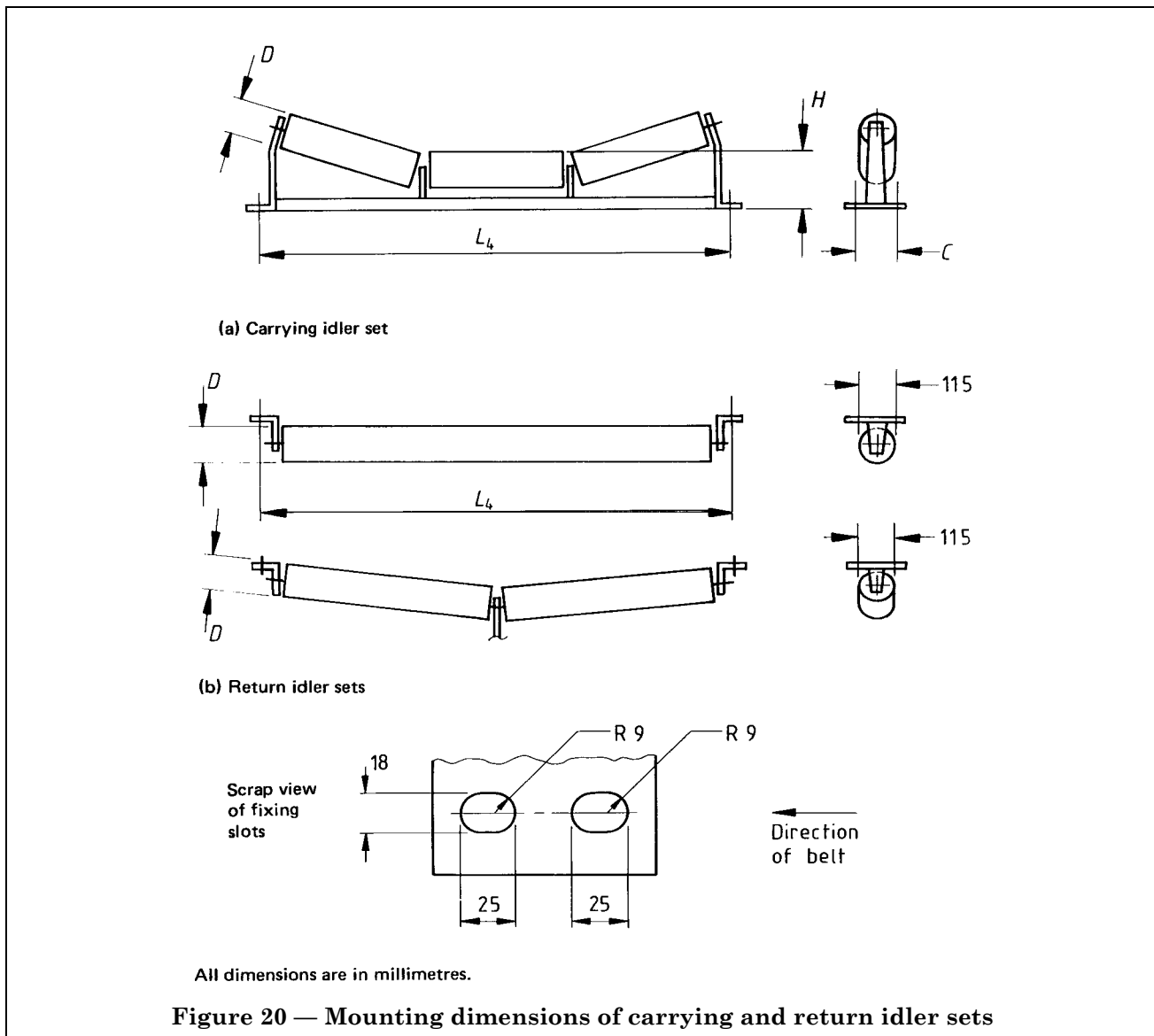
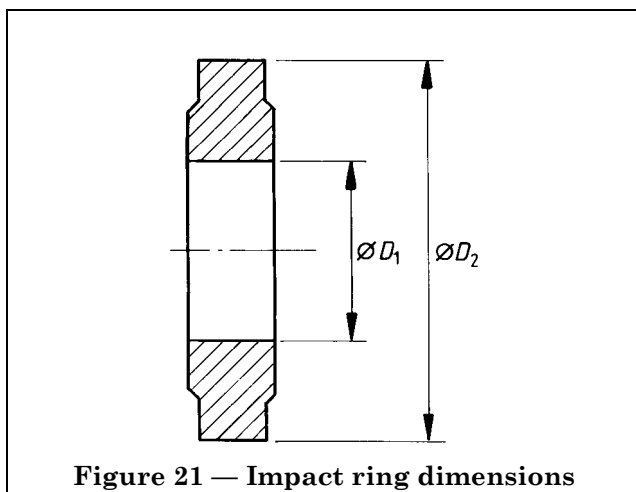

Figure 20 — Mounting dimensions of carrying and return idler sets

Table 13 — Impact ring for carrying idlers outside diameter

Nominal diameter D_1 of roller tube	Nominal outside diameter D_2 of impact ring
mm	mm
76.1	{ 127 152.4 168.3 178
88.9	178
168.3	200



7.13.3 Discs for return idlers. The nominal outside diameter of discs for return idlers (D_2 in Figure 22) for the associated roller tube diameter (D_1 in Figure 22) shall be in accordance with Table 14. The bore of the disc shall have an interference fit on the roller tube. The form of the disc shall be at the discretion of the manufacturer.

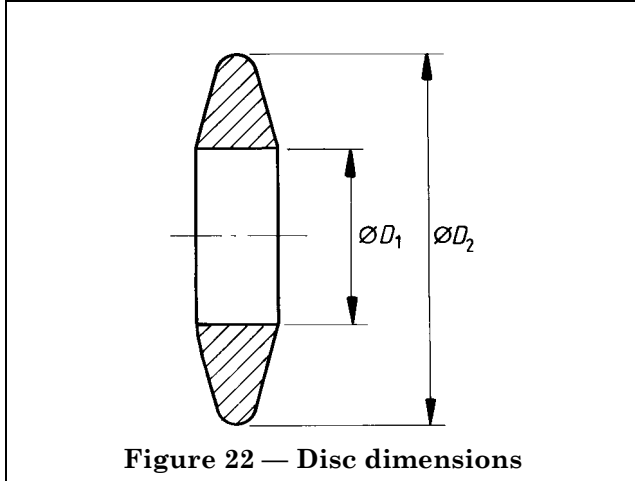

Table 14 — Discs for return idlers outside diameter

Nominal diameter D_1 of roller tube	Nominal outside diameter D_2 of disc for return idler
mm	mm
76.1	152.4
101.6	{ 152.4 { 178

8 Transition distances

Transition distances shall be in accordance with ISO 5293.

9 Take-up devices

Take-up devices shall comply with ISO 3870.

10 Power calculations

Power calculations shall be made in accordance with the method described in BS 5934.

Appendix A Information to be supplied by the purchaser

The following information should be supplied by the purchaser. These items do not form part of the requirements of this standard and are included for information only:

- a) material to be conveyed;
 - b) conditions: wet, dry, sticky, greasy, abrasive; if hot or cold, state temperature if known or describe conditions. Whether special cleaners are required;
 - c) density of material in kilograms per cubic metre;
 - d) size in millimetres of largest lumps (three dimensions);
 - e) average size in millimetres of materials;
 - f) approximate screen analysis of material;
 - g) chemical action on metals or rubber, if any;
 - h) method of handling the material immediately prior to feeding the conveyor;
 - i) whether the feed is to be regulated and type of feeder preferred;
 - j) conveyor duty in tonnes per hour, for a stated number of hours per day;
 - k) peak load which will be fed to conveyor in tonnes per minute;
 - l) type of belt joint preferred;
 - m) method of discharging conveyor;
 - n) amount of lift or fall;
 - o) initial length (centres of head and tail pulleys);
 - p) ultimate length (centres of head and tail pulleys);
 - q) method of supporting conveyor and whether supports are to be supplied;
 - r) type of power unit to be employed;
 - s) any restrictions as to positioning of driving gear;
 - t) description of power supply, i.e. voltage (in volts), whether a.c. or d.c., frequency in hertz and number of phases if a.c.;
 - u) any limitation on the use of direct-on-line motors;
 - v) statutory requirements applicable;
 - w) special safety precautions and safeguarding required;
- NOTE The purchaser may elect to provide all or part of the safeguards by agreement with the supplier and this may be a condition of the contract in the U K. The purchaser may be asked to sign an undertaking to this effect, indicating the extent of the safeguards to be provided by each party.
- x) contour sketch of proposed installation;
 - y) minimum basic rating life for idler bearings, if required to exceed 25 000 h;
 - z) any special features.

Appendix B Information to be supplied by the manufacturer, if required

The following information should be supplied by the manufacturer if requested by the purchaser. These items do not form part of the requirements of this standard and are included for information only:

- a) width of belt, construction, grade, thickness of carcass and covers, mass per metre and type of joint recommended; length of belt required for replacement, including jointing allowances;
- b) motive power required for the following:
 - 1) at motor shaft, if motor is supplied;
 - 2) at drive terminal shaft, if transmission is not included;
- c) belt speed in metres per second;
- d) type of take-up device, stating pulley diameters;
- e) details of trippers, if supplied, including right-or left-hand handling, propulsion (power, manual or belt propelled), type of brake, travelling speed and total mass;

- f) peak capacity of conveyor when handling the specified material (see Appendix A);
- g) type and location of cleaners;
- h) carrying and return idlers: material, shell thickness, diameter, bearings (ball, taper or parallel-roller), lubrication; grease or oil filled and mode of sealing adopted;
- i) carrying and return idler sets: pitch, method of support and number of idlers per set;
- j) driving gear: snub pulley diameter, driving pulley diameter, angle of wrap, whether bare or lagged, type of bearings, type of transmission and lubrication; power, rating, type and speed of motor; maximum starting current;
- k) for large conveyors: type and design of overload protection where fitted;
- l) type of anti-run-back and/or brake provided;
- m) the extent of guarding allowed for;
- n) relevant drawings showing the following:
 - 1) effective length of conveyors, maximum angle of inclination, average incline and direction of conveying;
 - 2) general cross section of conveyor structure showing details of decking protection, if provided;
 - 3) location of supports;
- o) details of any special features;
- p) names of subcontractors of specialist equipment.

Appendix C Capacity and cross section of a conveyor with a smooth patternless belt

The maximum capacity of a belt conveyor, l_v (in m^3/s), is calculated from the equation:

$$l_v = Svk$$

where

- S is the maximum cross section of the material on the belt (in m^2);
- v is the speed of the belt (in m/s);
- k is the installation slope factor.

The maximum cross-sectional area of material depends on the width of the belt, the shape of the trough and the surcharge angle of the material when it passes over the carrying idlers. Figure 23 shows the most usual trough section for a three-idler set for which the cross-sectional area of the material, S , is given in Table 15.

Table 15 gives the maximum cross-sectional area for material having surcharge angles $\rho = 0^\circ, 10^\circ, 20^\circ$ and 30° . The value of the surcharge angle depends on the conveyed material and on the distance it has to travel. For normally flowing material, a value for ρ of 20° can generally be chosen as a standard value. Easily flowing or almost fluid materials, however, attain a value of less than 20° and can drop down as far as 0° . Surcharge angles higher than 20° occur only for materials having a very high internal friction.

Table 15 gives the maximum cross section of the handled material for a range of belt widths, surcharge angles and troughing angles. The values of the maximum cross section of the handled material, S , are based on a load width, b in m , calculated from the equation:

$$b = \frac{0.9B}{1\ 000} - 0.05$$

where

- B is the belt width (in mm).

The slope factor k in the equation takes into account the decrease of the section of the handled material on the belt when a gradient of slope angle δ is part of the system. Figure 24 gives values for k as a function of the installation slope angle and only applies to smooth, patternless belts.

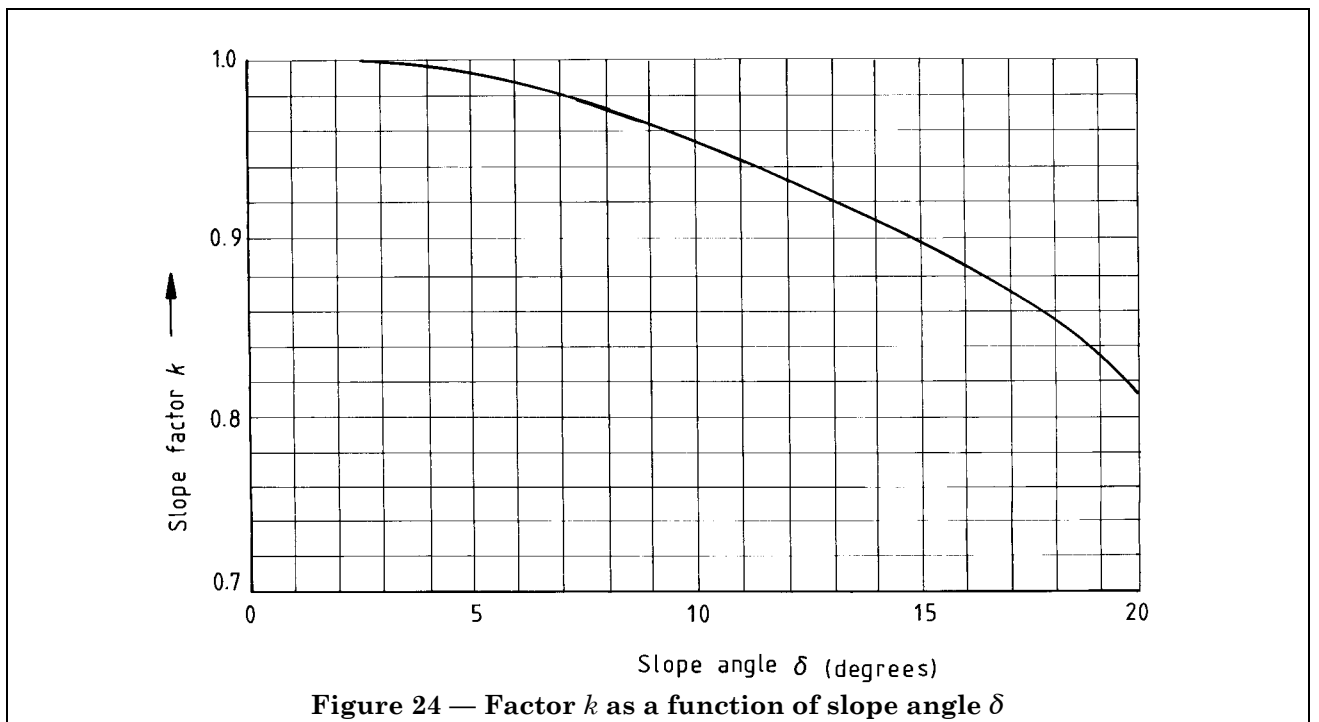
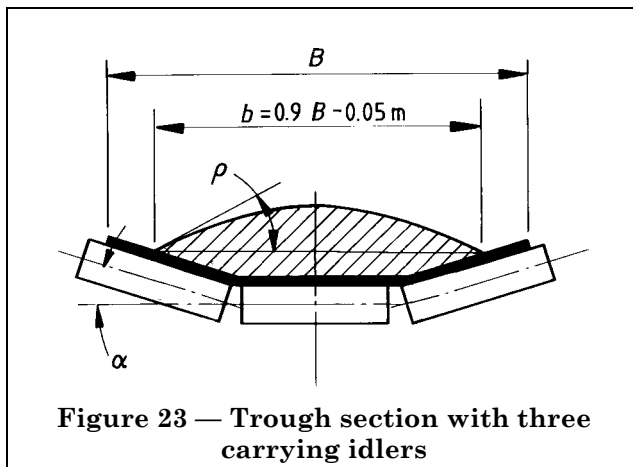

Table 15 — Maximum cross section of the handled material, S , for triple-roller troughed belts in accordance with Figure 23 with equal-length carrying idlers

Belt width, B	Surcharge angle, ρ	Troughing angle, α					
		20°	25°	30°	35°	40°	45°
		Maximum cross section of handled material, S					
mm	degrees	m ²	m ²	m ²	m ²	m ²	m ²
500	0	0.010	0.012	0.014	0.016	0.017	0.019
	10	0.014	0.016	0.018	0.020	0.021	0.022
	20	0.019	0.021	0.022	0.024	0.025	0.026
	30	0.023	0.025	0.027	0.028	0.029	0.029
650	0	0.018	0.022	0.026	0.029	0.032	0.035
	10	0.026	0.030	0.033	0.036	0.039	0.041
	20	0.034	0.038	0.041	0.043	0.045	0.047
	30	0.043	0.046	0.048	0.051	0.052	0.053
800	0	0.028	0.034	0.040	0.045	0.050	0.054
	10	0.041	0.047	0.052	0.056	0.060	0.064
	20	0.054	0.059	0.064	0.068	0.071	0.074
	30	0.067	0.072	0.076	0.080	0.082	0.084
1 000	0	0.048	0.058	0.068	0.076	0.084	0.090
	10	0.067	0.077	0.086	0.093	0.100	0.105
	20	0.088	0.097	0.104	0.111	0.116	0.120
	30	0.109	0.117	0.124	0.129	0.134	0.136
1 200	0	0.070	0.085	0.099	0.112	0.123	0.132
	10	0.099	0.113	0.126	0.137	0.146	0.154
	20	0.129	0.142	0.153	0.163	0.171	0.176
	30	0.160	0.172	0.182	0.190	0.196	0.200
1 400	0	0.098	0.120	0.139	0.157	0.171	0.184
	10	0.138	0.158	0.175	0.191	0.204	0.214
	20	0.179	0.197	0.213	0.220	0.237	0.245
	30	0.221	0.238	0.253	0.264	0.272	0.277
1 600	0	0.130	0.159	0.185	0.208	0.228	0.244
	10	0.182	0.209	0.233	0.253	0.270	0.283
	20	0.236	0.261	0.282	0.300	0.314	0.324
	30	0.293	0.315	0.334	0.349	0.360	0.366
1 800	0	0.167	0.203	0.237	0.266	0.292	0.313
	10	0.233	0.268	0.298	0.324	0.346	0.363
	20	0.302	0.334	0.361	0.384	0.401	0.414
	30	0.374	0.403	0.427	0.446	0.460	0.468
2 000	0	0.207	0.253	0.294	0.331	0.362	0.388
	10	0.290	0.332	0.370	0.403	0.429	0.450
	20	0.376	0.415	0.448	0.476	0.498	0.514
	30	0.468	0.501	0.530	0.554	0.571	0.581
2 200 ^a	0	0.257	0.311	0.363	0.408	0.446	0.478
	10	0.357	0.408	0.455	0.494	0.527	0.552
	20	0.461	0.508	0.549	0.584	0.610	0.629
	30	0.569	0.613	0.649	0.677	0.697	0.710
2 400 ^a	0	0.303	0.368	0.428	0.482	0.528	0.566
	10	0.423	0.484	0.539	0.586	0.625	0.656
	20	0.547	0.604	0.653	0.694	0.725	0.748
	30	0.677	0.729	0.772	0.806	0.830	0.845
2 600 ^a	0	0.360	0.439	0.510	0.573	0.628	0.672
	10	0.502	0.575	0.640	0.695	0.741	0.777
	20	0.648	0.716	0.774	0.822	0.859	0.885
	30	0.801	0.863	0.914	0.953	0.982	0.999
2 800 ^a	0	0.413	0.505	0.585	0.660	0.721	0.774
	10	0.578	0.663	0.737	0.803	0.885	0.897
	20	0.749	0.827	0.894	0.950	0.993	1.025
	30	0.928	0.998	1.063	1.104	1.137	1.158

^a Data for these belt widths is included for information only.

Appendix D Equation for calculating idler pitch for maximum sag of 2 %

The pitch of the idler, a (in m), for a maximum sag of 2 % may be calculated from the following equation:

$$a = \frac{0.0163T}{Wg_n}$$

where

T is the belt tension (in kN);

W is the mass per unit length of belting plus material load (in kg/m);

g_n is the acceleration due to gravity (in m/s^2).

NOTE In practice, it may be convenient to establish the idler pitch and adjust the belt tension to maintain a maximum sag of 2 %.

Appendix E Pitch of idler sets

Table 16 gives pitches for idler sets which will be found suitable for general use.

Table 16 — Typical pitch of idler sets with troughing angle up to 35°

Belt width	Density of material			Pitch for flat return idler sets
	kg/m ³ 400 to 1 200	kg/m ³ 1 201 to 2 000	kg/m ³ 2 001 to 2 800	
	Pitch			
mm	mm	mm	mm	mm
400 } 500 } 600 } 650 }	1 600	1 500	1 400	3 000
750 } 800 } 900 }	1 500	1 400	1 300	3 000
1 000 } 1 050 } 1 200 } 1 350 }	1 400	1 300	1 200	3 000
1 400 } 1 600 } 1 800 } 2 000 }	1 200	1 000	800	3 000

For wing idler inclinations greater than 35°, it may be necessary to decrease the pitch in order to maintain the troughed carrying capacity of the belt.

The return idler sets may prove suitable at increased pitch.

Publications referred to

- BS 24, *Railway rolling stock material.*
- BS 24-3B, *Specification for helical and volute springs and spring steels.*
- BS 46, *Keys and keyways and taper pins.*
- BS 46-1, *Specification for keys and keyways.*
- BS 228, *Specification for short pitch transmission precision roller chains and chainwheels.*
- BS 275, *Specification for dimensions of rivets (½ inch to 1¾ inch diameter).*
- BS 292, *Rolling bearings: ball bearings, cylindrical and spherical roller bearings.*
- BS 292-1, *Specification for dimensions of ball bearings, cylindrical and spherical roller bearings (metric series).*
- BS 292-2, *Specification for dimensions of ball bearings and cylindrical roller bearings (inch series).*
- BS 302, *Stranded steel wire ropes.*
- BS 302-1, *Specification for general requirements.*
- BS 302-2, *Specification for ropes for general purposes.*
- BS 490, *Conveyor and elevator belting.*
- BS 490-1, *Specification for rubber and plastics conveyor belting of textile construction for general use.*
- BS 856, *Specification for wing nuts.*
- BS 970, *Specification for wrought steels for mechanical and allied engineering purposes.*
- BS 970-1, *General inspection and testing procedures and specific requirements for carbon, carbon manganese, alloy and stainless steels.*
- BS 1004, *Specification for zinc alloys for die casting and zinc alloy die castings.*
- BS 1052, *Specification for mild steel wire for general engineering purposes.*
- BS 1400, *Specification for copper alloy ingots and copper alloy and high conductivity copper castings.*
- BS 1449, *Steel plate, sheet and strip.*
- BS 1449-1, *Specification for carbon and carbon manganese plate, sheet and strip.*
- BS 1449-2, *Specification for stainless and heat-resisting steel plate, sheet and strip.*
- BS 1452, *Specification for grey iron castings.*
- BS 1470, *Specification for wrought aluminium and aluminium alloys for general engineering purposes: plate, sheet and strip.*
- BS 1471, *Specification for wrought aluminium and aluminium alloys for general engineering purposes: drawn tube.*
- BS 1472, *Specification for wrought aluminium and aluminium alloys for general engineering purposes: forging stock and forgings.*
- BS 1473, *Specification for wrought aluminium and aluminium alloys for general engineering purposes: rivet, bolt and screw stock.*
- BS 1474, *Specification for wrought aluminium and aluminium alloys for general engineering purposes: bars, extruded round tubes and sections.*
- BS 1475, *Wrought aluminium and aluminium alloys for general engineering purposes. Wire.*
- BS 1486, *Lubricating nipples.*
- BS 1486-1, *Lubricating nipples and adaptors for use on machinery and vehicles.*
- BS 1486-2, *Heavy duty lubricating nipples.*
- BS 2059, *Specification for straight-sided splines and serrations.*
- BS 3027, *Specification for dimensions of worm gear units.*
- BS 3100, *Specification for steel castings for general engineering purposes.*
- BS 3134, *Metric tapered roller bearings.*
- BS 3134-1, *Specification for dimensions and tolerances of single row bearings.*
- BS 3134-2, *Specification for dimensions of double row bearings.*
- BS 3134-3, *Specification for dimensions of flanged cups.*
- BS 3643, *ISO metric screw threads.*

- BS 3643-1, *Principles and basic data.*
- BS 3643-2, *Specification for selected limits of size.*
- BS 3692, *Specification for ISO metric precision hexagon bolts, screws and nuts. Metric units.*
- BS 3790, *Specification for endless wedge belt drives and endless V-belt drives.*
- BS 4183, *Specification for machine screws and machine screw nuts. Metric series.*
- BS 4190, *Specification for ISO metric black hexagon bolts, screws and nuts.*
- BS 4219, *Slotted set screws: metric series.*
- BS 4219-1, *Specification for slotted set screws with flat point.*
- BS 4219-2, *Specification for slotted set screws with cone point.*
- BS 4219-3, *Specification for slotted set screws with long dog point.*
- BS 4219-4, *Specification for slotted set screws with cup point.*
- BS 4235, *Specification for metric keys and keyways.*
- BS 4235-1, *Parallel and taper keys.*
- BS 4320, *Specification for metal washers for general engineering purposes. Metric series.*
- BS 4360, *Specification for weldable structural steels.*
- BS 4395, *Specification for high strength friction grip bolts and associated nuts and washers for structural engineering.*
- BS 4395-1, *General grade.*
- BS 4429, *Specification for rigging screws and turnbuckles for general engineering, lifting purposes and pipe hanger applications.*
- BS 4439, *Specification for screwed studs for general purposes. Metric series.*
- BS 4463, *Specification for crinkle washers for general engineering purposes. Metric sizes.*
- BS 4464, *Spring washers for general engineering and automobile purposes (metric series).*
- BS 4500, *ISO limits and fits.*
- BS 4500-1, *General, tolerances and deviations.*
- BS 4500-3, *Working limits on untoleranced dimensions.*
- BS 4531, *Specification for portable and mobile troughed belt conveyors.*
- BS 4848, *Hot-rolled structural steel sections.*
- BS 4848-4, *Equal and unequal angles.*
- BS 4978, *Timber grades for structural use.*
- BS 5000, *Rotating electrical machines of particular types or for particular applications.*
- BS 5000-99, *Machines for miscellaneous applications.*
- BS 5135, *Specification for process of arc welding of carbon and carbon manganese steels.*
- BS 5512, *Specification for rolling bearings — Dynamic load ratings and rating life.*
- BS 5512-1, *Calculation methods.*
- BS 5934, *Method for calculation of operating power and tensile forces in belt conveyors with carrying idlers on continuous mechanical handling equipment.*
- BS 6323, *Specification for seamless and welded steel tubes for automobile, mechanical and general engineering purposes.*
- BS 6323-1, *General requirements.*
- BS 6323-2, *Specific requirements for hot finished welded steel tubes.*
- BS 6323-3, *Specific requirements for hot finished seamless steel tubes.*
- BS 6323-4, *Specific requirements for cold finished seamless steel tubes.*
- BS 6323-5, *Specific requirements for electric resistance welded and induction welded steel tubes.*
- BS 6323-6, *Specific requirements for cold finished electric resistance welded and induction welded steel tubes.*
- BS 6323-7, *Specific requirements for submerged arc welded steel tubes.*
- BS 6323-8, *Specific requirements for longitudinally welded stainless steel tubes.*
- BS 6681, *Specification for malleable cast iron.*
- PD 6481, *Recommendations for the use of preferred numbers and preferred sizes.*
- ISO 251, *Conveyor belts — Widths and lengths.*

ISO 1535, *Continuous mechanical handling equipment for loose bulk materials — Troughed belt conveyors (other than portable conveyors) — Belts.*

ISO 1536, *Continuous mechanical handling equipment for loose bulk materials — Troughed belt conveyors (other than portable conveyors) — Belt pulleys.*

ISO 1537, *Continuous mechanical handling equipment for loose bulk materials — Troughed belt conveyors (other than portable conveyors) — Idlers.*

ISO 1816, *Continuous mechanical handling equipment for loose bulk materials and unit loads — Belt conveyors — Basic characteristics of motorized driving pulleys.*

ISO 2109, *Continuous mechanical handling equipment — Light duty belt conveyors for loose bulk material.*

ISO 3870, *Conveyor belts (fabric carcass), with length between pulley centres up to 300 m, for loose bulk materials — Adjustment of take-up device.*

ISO 5293, *Conveyor belts — Formula for transition distance on three equal length idler rolls.*

BSI — British Standards Institution

BSI is the independent national body responsible for preparing British Standards. It presents the UK view on standards in Europe and at the international level. It is incorporated by Royal Charter.

Revisions

British Standards are updated by amendment or revision. Users of British Standards should make sure that they possess the latest amendments or editions.

It is the constant aim of BSI to improve the quality of our products and services. We would be grateful if anyone finding an inaccuracy or ambiguity while using this British Standard would inform the Secretary of the technical committee responsible, the identity of which can be found on the inside front cover. Tel: 020 8996 9000. Fax: 020 8996 7400.

BSI offers members an individual updating service called PLUS which ensures that subscribers automatically receive the latest editions of standards.

Buying standards

Orders for all BSI, international and foreign standards publications should be addressed to Customer Services. Tel: 020 8996 9001. Fax: 020 8996 7001.

In response to orders for international standards, it is BSI policy to supply the BSI implementation of those that have been published as British Standards, unless otherwise requested.

Information on standards

BSI provides a wide range of information on national, European and international standards through its Library and its Technical Help to Exporters Service. Various BSI electronic information services are also available which give details on all its products and services. Contact the Information Centre. Tel: 020 8996 7111. Fax: 020 8996 7048.

Subscribing members of BSI are kept up to date with standards developments and receive substantial discounts on the purchase price of standards. For details of these and other benefits contact Membership Administration. Tel: 020 8996 7002. Fax: 020 8996 7001.

Copyright

Copyright subsists in all BSI publications. BSI also holds the copyright, in the UK, of the publications of the international standardization bodies. Except as permitted under the Copyright, Designs and Patents Act 1988 no extract may be reproduced, stored in a retrieval system or transmitted in any form or by any means – electronic, photocopying, recording or otherwise – without prior written permission from BSI.

This does not preclude the free use, in the course of implementing the standard, of necessary details such as symbols, and size, type or grade designations. If these details are to be used for any other purpose than implementation then the prior written permission of BSI must be obtained.

If permission is granted, the terms may include royalty payments or a licensing agreement. Details and advice can be obtained from the Copyright Manager. Tel: 020 8996 7070.