



Spectacle lenses —

Part 1: Specification for tolerances on optical properties of mounted spectacle lenses

ICS 11.040.70

Committees responsible for this British Standard

The preparation of this British Standard was entrusted by Technical Committee CH/78, Ophthalmic optics, to Subcommittee CH/78/3, Spectacle lenses, upon which the following bodies were represented:

Association of British Dispensing Opticians
 Association of Contact Lens Manufacturers
 British Medical Association
 College of Optometrists
 Consumer Policy Committee of BSI
 Department of Health (Medical Devices Agency)
 Federation of Manufacturing Opticians
 Federation of Ophthalmic and Dispensing Opticians
 Flat Glass Manufacturers' Association
 Institution of Mechanical Engineers
 Royal College of Ophthalmologists
 Coopted members

This British Standard, having been prepared under the direction of the Health and Environment Sector Board, was published under the authority of the Standards Board and comes into effect on 15 November 1998

© BSI 1998

First published as BS 2738 :
 Part 1, February 1989
 Second edition, November 1998

The following BSI references relate to the work on this standard:
 Committee reference CH/78/3
 Draft for comment 97/563490 DC

ISBN 0 580 28222 8

Amendments issued since publication

Amd. No.	Date	Text affected

Contents

	Page
Committees responsible	Inside front cover
Foreword	ii
<hr/>	
1 Scope	1
2 Normative references	1
3 Definitions	1
4 Classification	1
5 Requirements	1
6 Permanent marking of progressive power lenses	3
7 Test methods	3
<hr/>	
Annex A (informative) Recommendations regarding subjective characteristics of spectacle lenses	6
Annex B (informative) Method for evaluating progressive power lens characteristics	8
<hr/>	
Bibliography	9
<hr/>	
Figure 1 — Use of a focimeter to measure the addition power of a front surface multifocal or progressive power lens	4
Figure 2 — Measurement of the addition power	5
Figure A.1 — Recommended system for visually inspecting a lens for defects	6
Figure A.2 — Front view of round lenses illustrating marks (exaggerated) on back surfaces denoting right and left	7
Figure B.1 — Measurement of the optical characteristics in the as-worn position	8
<hr/>	
Table 1 — Tolerances on the back vertex power of single-vision and multifocal lenses	2
Table 2 — Tolerances on the back vertex power of progressive power lenses	2
Table 3 — Tolerances on the direction of the cylinder axis	2
Table 4 — Tolerances on the addition power for multifocal and progressive power lenses	2
Table 5 — Centration tolerances	3
Table 6 — Prism tolerances	3
<hr/>	

Foreword

This part of BS 2738 has been prepared by Technical Committee CH/78. It supersedes BS 2738-1:1989 which is withdrawn.

It has been assumed in the drafting of this British Standard that the execution of its provisions is entrusted to appropriately qualified and experienced people.

Like the 1989 edition, this standard is not a specification for mounted lenses; it specifies the tolerances that apply to the nominal values on the prescription order. Application of this standard will therefore result in lenses with optical properties that conform in a standard manner to the prescription order in respect of the lens power, the cylinder axes, the base setting and power of prisms, the centration and linear dimensions. The permitted tolerances for uncut finished lenses are now specified in BS EN ISO 8980-1:1997 (BS 2738-6:1996) and BS EN ISO 8980-2:1997 (BS 2738-7:1996).

As recommended in BS 2738-3:1991, values for dioptric power are designated throughout this standard with two digits after the decimal point.

This standard has been revised to align the tolerances with those in BS EN ISO 8980-1:1997 (BS 2738-6:1996) and BS EN ISO 8980-2:1997 (BS 2738-7:1996). At the same time, the opportunity has been taken to clarify the centration tolerance between the optical centres of the two lenses. It should be noted that in Table 5, the first column relates to dioptric power (D) whereas in Table 6 it relates to prismatic power (Δ).

At the time of publication, the other parts of BS 2738 were as follows:

Part 3, *Spectacle lenses — Specification for the presentation of prescriptions and prescription orders for ophthalmic lenses.*

Part 4 (BS EN ISO 10322-1), *Ophthalmic optics — Semi-finished spectacle lens blanks — Specifications for single vision and multifocal lens blanks.*

Part 5 (BS EN ISO 10322-2), *Ophthalmic optics — Semi-finished spectacle lens blanks — Specifications for progressive power lens blanks.*

Part 6 (BS EN ISO 8980-1), *Ophthalmic optics — Uncut finished spectacle lenses — Specifications for single-vision and multifocal lenses.*

Part 7 (BS EN ISO 8980-2), *Ophthalmic optics — Uncut finished spectacle lenses — Specifications for progressive power lenses.*

Part 8 (BS EN ISO 14889), *Spectacle lenses — Fundamental requirements for uncut finished lenses.*

A British Standard does not purport to include all the necessary provisions of a contract. Users of British Standards are responsible for their correct application.

Compliance with a British Standard does not of itself confer immunity from legal obligations.

Summary of pages

This document comprises a front cover, an inside front cover, pages i and ii, pages 1 to 9, and a back cover.

1 Scope

This part of BS 2738 specifies, with reference to the prescription order (see note 2), tolerances for properties of mounted spectacle lenses.

This standard is not applicable to the transmission properties of tinted, coated or otherwise treated lenses nor to the material from which the lens is manufactured.

NOTE 1 Ophthalmic lens materials are specified in BS 3062 (to be replaced by ISO 8980-3). BS 7394-2 specifies requirements for glazing and lens robustness.

Recommendations regarding other characteristics of spectacle lenses that are related to tolerances, but are subjective and therefore cannot be specified, are given in annex A.

NOTE 2 It is assumed that the prescription order conforms to BS 2738-3.

2 Normative references

The following normative documents contain provisions which, through reference in this text, constitute provisions of this part of this British Standard. For dated references, subsequent amendments to, or revisions of, any of these publications do not apply. For undated references, the latest edition of the publication referred to applies.

BS 2738-3, *Spectacle lenses — Part 3: Specification for the presentation of prescriptions and prescription orders for ophthalmic lenses.*

BS 7017, *Specification for reference wavelengths for optics and optical instruments.*

BS EN ISO 8980-1 (BS 2738-6), *Ophthalmic optics — Uncut finished spectacle lenses — Part 1: Specifications for single-vision and multifocal lenses.*

BS EN ISO 8980-2 (BS 2738-7), *Ophthalmic optics — Uncut finished spectacle lenses — Part 2: Specifications for progressive power lenses.*

BS EN ISO 14889 (BS 2738-8) *Spectacle lenses — Fundamental requirements for uncut finished lenses.*

BS ISO 8598, *Optics and optical instruments — Focimeters.*

ISO 13666, *Ophthalmic optics — Spectacle lenses — Vocabulary.*

3 Definitions

For the purposes of this part of BS 2738, the definitions given in ISO 13666 apply.

4 Classification

Lenses are classified as follows:

- a) single-vision finished lenses;
- b) multifocal finished lenses;
- c) progressive power finished lenses.

5 Requirements

5.1 Temperature

The tolerances shall apply at a temperature of $(23 \pm 5) ^\circ\text{C}$.

5.2 Optical requirements

5.2.1 General

Before glazing, lenses shall conform to either BS EN ISO 8980-1 (BS 2738-6) or BS EN ISO 8980-2 (BS 2738-7) and to BS EN ISO 14889 (BS 2738-8).

The optical tolerances shall apply at the reference points of the lens at one of the reference wavelengths specified in BS 7017.

Where the manufacturer has applied corrections to compensate for the as-worn position, then the tolerances shall apply to the corrected value. This corrected value shall be stated by the manufacturer on the package or in an accompanying document.

For progressive power lenses, the measured addition power can be influenced by the prescription, and, in particular cases, e.g. oblique cylinders or high minus powers, the deviation of the measured addition power can exceed the above mentioned tolerances; in these cases the manufacturer shall submit corrected values on request.

5.2.2 Tolerances on the back vertex power of single-vision lenses and on the distance portion of multifocal and progressive power lenses

5.2.2.1 Tolerances on the back vertex power of lenses

Lenses shall conform to the tolerances on the power of each meridian, A , and to the tolerances on the cylindrical power, B , given in Table 1 or Table 2, as applicable.

Table 1 — Tolerances on the back vertex power of single-vision and multifocal lenses

Values in dioptres

Power of meridian with highest absolute power	Tolerance on the power of each meridian, <i>A</i>	Tolerance on the cylindrical power, <i>B</i>			
		≥ 0.00 and ≤ 0.75	> 0.75 and ≤ 4.00	> 4.00 and ≤ 6.00	> 6.00
≥ 0.00 and ≤ 3.00	± 0.12	± 0.09	± 0.12	± 0.18	± 0.25
> 3.00 and ≤ 6.00	± 0.12	± 0.12	± 0.12	± 0.18	± 0.25
> 6.00 and ≤ 9.00	± 0.12	± 0.12	± 0.18	± 0.18	± 0.25
> 9.00 and ≤ 12.00	± 0.18	± 0.12	± 0.18	± 0.25	± 0.25
> 12.00 and ≤ 20.00	± 0.25	± 0.18	± 0.25	± 0.25	± 0.25
> 20.00	± 0.37	± 0.25	± 0.25	± 0.37	± 0.37

Table 2 — Tolerances on the back vertex power of progressive power lenses

Values in dioptres

Power of meridian with highest absolute power	Tolerance on the power of each meridian, <i>A</i>	Tolerance on the cylindrical power, <i>B</i>			
		≥ 0.00 and ≤ 0.75	> 0.75 and ≤ 4.00	> 4.00 and ≤ 6.00	> 6.00
≥ 0.00 and ≤ 6.00	± 0.12	± 0.12	± 0.18	± 0.18	± 0.25
> 6.00 and ≤ 9.00	± 0.18	± 0.18	± 0.18	± 0.18	± 0.25
> 9.00 and ≤ 12.00	± 0.18	± 0.18	± 0.18	± 0.25	± 0.25
> 12.00 and ≤ 20.00	± 0.25	± 0.18	± 0.25	± 0.25	± 0.25
> 20.00	± 0.37	± 0.25	± 0.25	± 0.37	± 0.37

5.2.2.2 Tolerances on the direction of the cylinder axis

The direction of the cylinder axis, measured using the method given in 7.2 shall conform to the tolerances specified in Table 3.

Table 3 — Tolerances on the direction of the cylinder axis

Cylindrical power Dioptres	Tolerances on the cylinder axis Degrees
≤ 0.50	± 7
> 0.50 and ≤ 0.75	± 5
> 0.75 and ≤ 1.50	± 3
> 1.50	± 2

5.2.3 Tolerances on the addition power for multifocal and progressive power lenses**5.2.3.1 Multifocal lenses**

The addition power for multifocal lenses, measured using the method described in 7.3, shall conform to the tolerances specified in Table 4.

5.2.3.2 Progressive power lenses

The addition power for progressive power lenses, measured using the method described in 7.4, shall conform to the tolerances specified in Table 4.

Table 4 — Tolerances on the addition power for multifocal and progressive power lenses

Values in dioptres

Value of the addition power	Tolerance
≤ 4.00	± 0.12
> 4.00	± 0.18

Table 5 — Centration tolerances

Meridional lens powers D	Horizontal tolerance	Vertical tolerance
Both lenses: power < 2.00	0.25 Δ and 2.0 mm displacement	0.25 Δ and 1.0 mm total displacement
Both lenses: power ≥ 2.00	2.0 mm total displacement	1.0 mm total displacement
One lens < 2.00 and one lens ≥ 2.00	0.12 Δ and 2.0 mm displacement	0.12 D and 1.0 mm total displacement

5.2.4 Optical centration. Pairing tolerance

5.2.4.1 Lenses without ordered prism or with ordered prism powers ≤ 2.00 Δ in each lens

After neutralizing any prescribed or thickness reducing prism, the tolerance on the relative prism between the two lenses of a pair when measured at the centration points shall be as given in Table 5.

NOTE 1 It should be noted that in Table 5, the first column relates to dioptric power (D) whereas in Table 6 it relates to prismatic power (Δ).

The horizontal and vertical components of prisms shall be toleranced separately.

NOTE 2 The positioning tolerances given in 5.3.1 or 5.3.2 may be used to reduce any relative prism that would otherwise be produced by the individual prism tolerances allowed in BS EN ISO 8980-1 (BS 2738-6) and BS EN ISO 8980-2 (BS 2738-7).

5.2.4.2 Additional tolerance for lenses where one or both incorporate ordered prismatic powers > 2.00 Δ

For pairs of lenses where either or both lenses incorporate ordered prismatic power > 2.00 Δ, an additional tolerance on the relative prismatic power between the two lenses shall be as given in Table 6.

The horizontal and vertical components of prisms shall be toleranced separately.

NOTE The positioning tolerances given in 5.3.1 or 5.3.2 may be used to reduce any relative prism that would otherwise be produced by the individual prism tolerances allowed in BS EN ISO 8980-1 (BS 2738-6) and BS EN ISO 8980-2 (BS 2738-7).

Table 6 — Prism tolerances

Relative prismatic power Δ	Additional tolerance Δ
> 2.00 up to ≤ 10.00	±0.37
> 10.00	±0.50

5.3 Geometrical and positioning tolerances

5.3.1 Multifocal lenses

When using one of the methods described in 7.5, each of the segment dimensions (width, depth and intermediate depth) shall not deviate from its nominal value by more than ±0.5 mm.

For each lens, the tolerance on the positioning of the segment top (or bottom), relative to the spectacle frame, shall not be more than ±0.5 mm horizontally and vertically from the ordered position.

For multifocal lenses with straight top segments, the tilt of the straight portion of the segment dividing line shall be less than 2°.

5.3.2 Progressive power lenses

For each lens, the tolerance on the positioning of the manufacturer's permanent markings, relative to the spectacle frame, shall not be more than 0.5 mm from the ordered position in any direction.

6 Permanent marking of progressive power lenses

The lens shall be permanently marked with at least the following:

- the alignment reference markings comprising two marks located 34 mm apart, equidistant from a vertical plane through the fitting point or prism reference point;
- indication of addition power, in dioptres;
- indication of the manufacturer, or supplier, or trade name, or trade mark.

NOTE The following optional non-permanent marking is recommended:

- the alignment reference marking;
- indication of the distance reference point;
- indication of the near reference point;
- indication of the fitting point;
- indication of the prism reference point.

7 Test methods

7.1 General

The optical power shall be determined using a focimeter conforming to BS ISO 8598 or using an equivalent method.

If a focusing focimeter is used to measure the addition power of multifocal or progressive power lenses, the more nearly vertical lines of the target shall be focused when measuring the near and distance vertex powers.

7.2 Cylinder axis and prism base setting measurement method

Measure the cylinder axis and prism base setting in relation to the horizontal as determined by the spectacle frame.

7.3 Addition power measurement: multifocal lenses

Place the lens so that the surface containing the addition segment is against the focimeter lens support (see Figure 1a) and centralize the lens at the near reference point.

Measure the near vertex power.

Establish the distance vertex power measurement point D (see Figure 2), which is at the same distance above and to the side of the distance reference point B as the near vertex power measurement point N is from B. Then place the lens against the focimeter lens support (see Figure 1b) and centralize the lens at D.

Measure the distance vertex power.

Calculate the addition power as the difference between the near vertex power and the distance vertex power.

NOTE 1 Alternative measurement methods are acceptable if shown to perform equivalently to the above reference method.

NOTE 2 In the case of an aspheric lens, the distance reference point should be specified by the manufacturer.

NOTE 3 In the case of negative lenses with negative distance powers of 6.00 D or more, back vertex power measurement methods are permitted. If the lens is designed according to the back vertex power measuring method, this should be stated by the manufacturer.

7.4 Addition power measurement method: progressive power lenses

Place the lens so that the progressive side is against the focimeter lens support (see Figure 1a) and centralize the lens at the near reference point.

Measure the near vertex power.

Then measure the distance vertex power at the distance reference point, with the progressive surface against the focimeter lens support (see Figure 1b).

Calculate the addition power as the difference between the near vertex power and the distance vertex power.

NOTE 1 Alternative measurement methods are acceptable if shown to perform equivalently to the above reference method.

In the case of a special conception design, if the reference method is not applicable, the manufacturer shall specify the reference points for the addition measurement.

NOTE 2 In the case of negative lenses with negative distance powers of 6.00 D or more, back vertex power measurement methods are permitted. If the lens is designed according to the back vertex power measuring method, this should be stated by the manufacturer.

NOTE 3 If the manufacturer publishes information on the evaluation of a progressive power lens, the method of determination of those characteristics should be based on the method indicated in annex B.

7.5 Segment size measurement method

Measure the segment size in the tangential plane to the segment centre using a shadowgraph, an optical comparator fitted with the appropriate graticule or a precision millimetric measuring instrument.

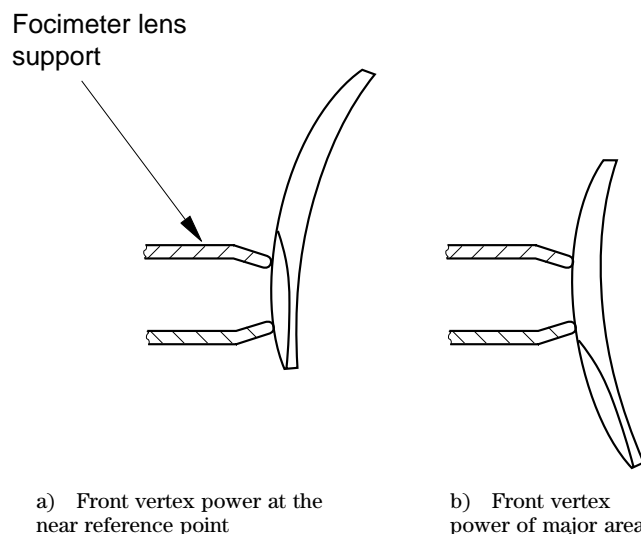
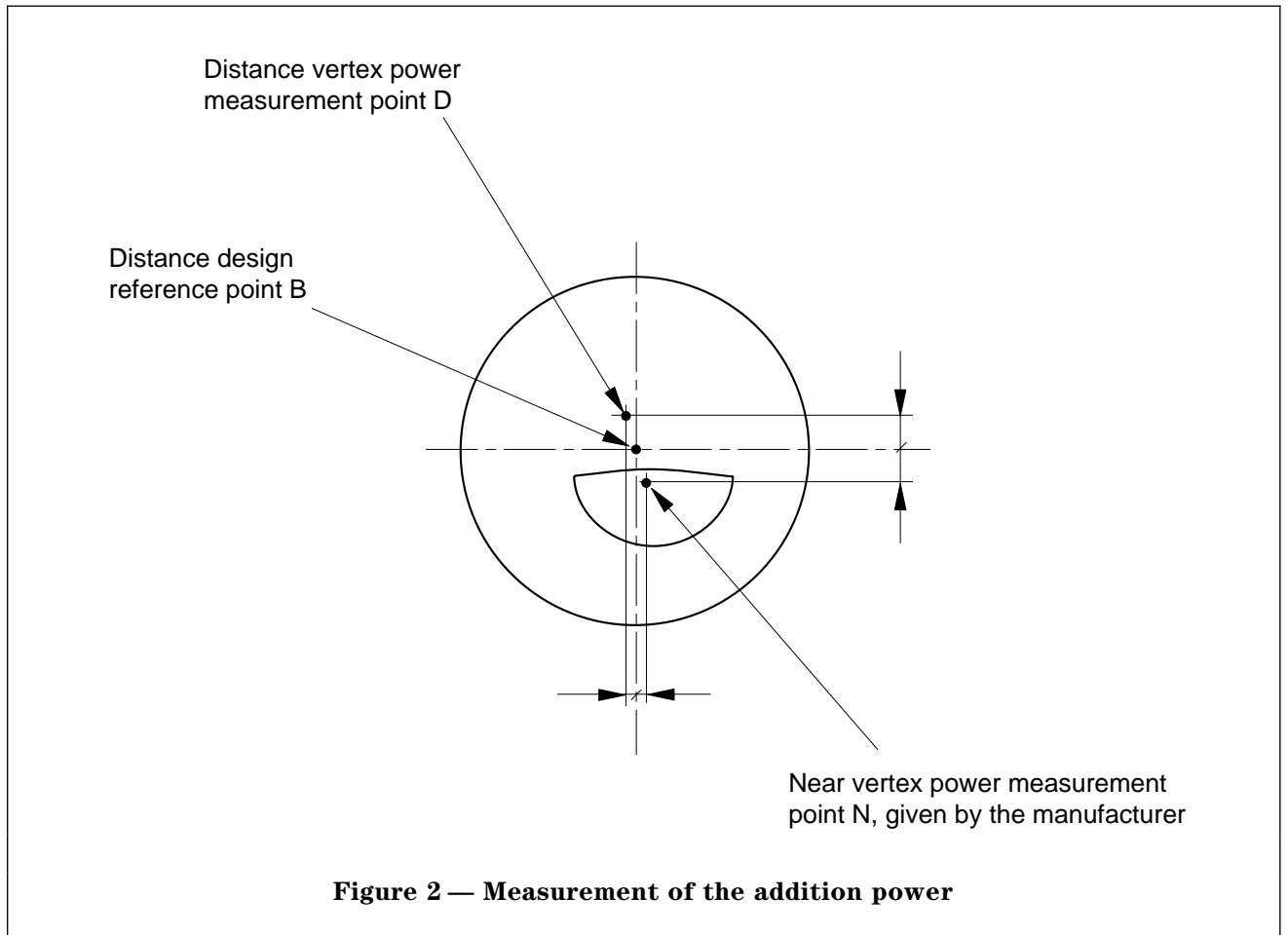

Figure 1 — Use of a focimeter to measure the addition power of a front surface multifocal or progressive power lens



Annex A (informative)

Recommendations regarding subjective characteristics of spectacle lenses

A.1 Lens pairs

The two lenses of a pair should be reasonably matched in shape, size, form and mass and, except where necessary for matching purposes, should not be substantially thicker than is required to give mechanical stability.

NOTE In certain cases a satisfactory match may require lenses to be specially worked.

A.2 Material and surface quality

A.2.1 Assessment

In the inspection zone detailed in item a), b) or c), as applicable, the lens should not exhibit any defect either internally or on the surfaces which may impair vision. Outside this zone, small isolated material and/or surface defects are acceptable.

a) *Single-vision lenses.* The inspection zone is an area 30 mm in diameter centred around the reference point.

b) *Multifocal lenses.* The inspection zone comprises two areas: a zone of 30 mm diameter, centred around the distance reference point, and also, either the whole area of the segment if the segment is not more than 30 mm in diameter, or, for segments over 30 mm in diameter, a 30 mm diameter zone centred around the near design reference point.

c) *Progressive power lenses.* The inspection zone is an area 30 mm in diameter, centred around the prism reference point, together with a zone of 10 mm diameter centred around the near reference point.

A.2.2 Test method

Carry out the lens inspection at a light/dark boundary and without the aid of magnifying optics. The recommended system is shown in Figure A.1. Inspect the lens within a room with ambient lighting of about 200 lx. Use a source of at least 400 lm as an inspection lamp, for example a fluorescent tube of 15 W or a partially shaded 40 W incandescent clear lamp.

NOTE This observation method is subjective and requires some experience.

A.3 Glazing

A.3.1 Bevelled lenses

The bevel should be smooth, regular, free from chips and starring and reasonably free from facets, with a safety chamfer at the peak and at each edge where necessary. When mounted, the lenses should be free from excessive strain caused in mounting, but should be securely held in position so that movement or rotation in the frame cannot occur under any normal condition of use. Lenses after mounting should not depart significantly from the strain pattern of the edged lens. No gaps should be visible between the edge of the lens and the rim. The halves of joints should close properly without undue force and without leaving a noticeable gap at the joint.

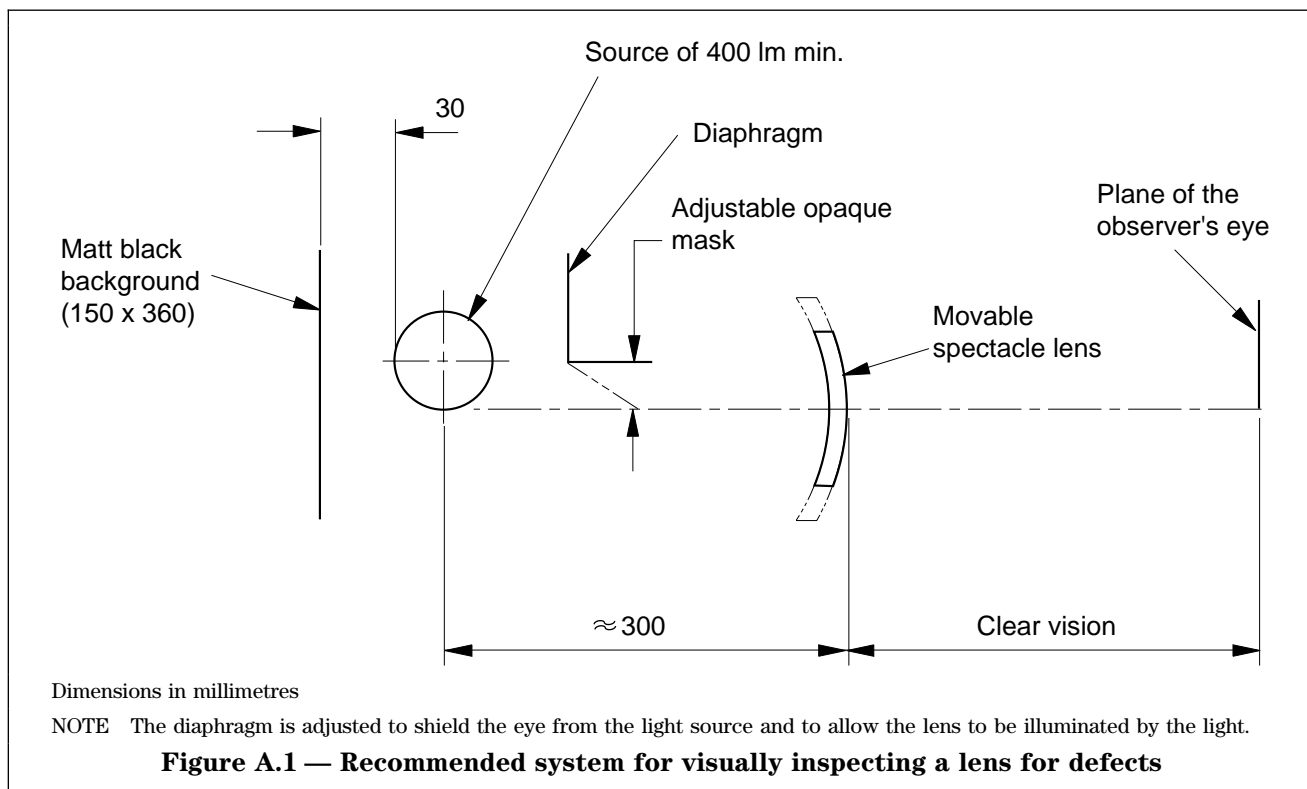

A.3.2 Rimless and other lenses

Flat-edged lenses should present a smooth finish with a neat safety chamfer at each edge.

Holes for rimless fittings should be drilled at the correct distance from the edge according to the type of mounting. Slots and grooves when required should be accurately positioned. Brow-bars should be carefully adjusted to follow the edge of the lens. The ends of screws should be neatly finished.

All lenses should be neatly and carefully fitted to ensure that they are securely held in position yet show no significant strain when examined in a polariscope or strainviewer.

A.4 Setting of round lenses

The setting position of round lenses (except those of thermally-toughened glass) should be indicated by means of permanent marks placed next to the joint on the back lens surface as follows:

- a) on the right lens, one mark on the joint line;
- b) on the left lens, two marks placed symmetrically one either side of the joint line (see Figure A.2).

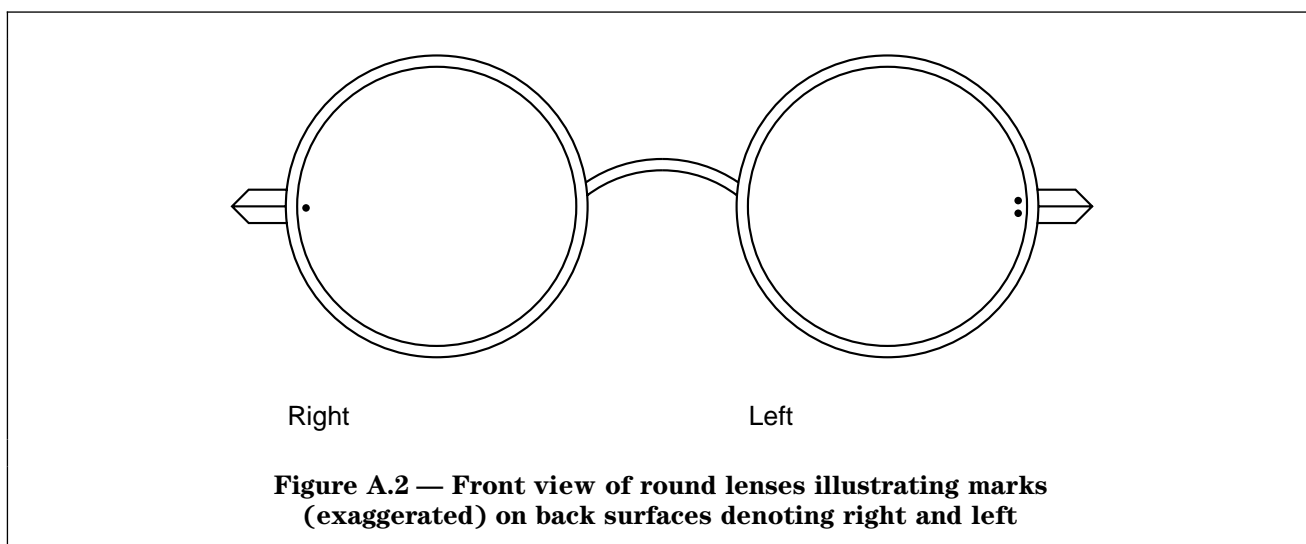

Annex B (informative)

Method for evaluating progressive power lens characteristics

B.1 The purpose of this annex is to provide a method for assessing certain optical properties of progressive addition lenses. There is no intention to standardize what the optics should be nor how those optics affect the use or acceptance of these lenses.

Other methods which provide measurements that are equivalent to those determined using this method are also acceptable.

B.2 The characterization may be composed of several parameters, but should at least include spherical equivalent and astigmatism, as follows.

- a) Spherical equivalent is the mean of the two principal meridian powers (F_1 and F_2) at any point on the lens.
- b) Astigmatism is the difference between the principal meridian powers.

It is possible also to measure and plot other parameters such as the prism.

Future developments may indicate which measures are the most useful.

A focimeter which conforms to BS ISO 8598 and which has been specially adapted for the purpose should be used for measuring these characteristics in the as-worn position. The manufacturer should specify the aperture used in the measuring instrument.

The principal ray path (or the instrument axis, if applicable) should intersect both the measuring point and the optical centre of rotation of the eye (see Figure B.1). It should be possible to adjust the angle δ' to at least $\pm 40^\circ$ from the fitting point in all directions except for the downward direction for which it should be greater than or equal to 45° .

For progressive addition lens characteristics a measurement with infinity distance has been chosen.

The recommended representations of the optical measurements across the lens are contour plot diagrams.

The reference test lenses for semi-finished lens blanks of base curve specified by the manufacturer's surfacing chart should have the following characteristics:

- distance power: plano;
- addition power: + 2.000 D.

For other base curves and addition powers the manufacturer should indicate the base curve, distance power and addition power of the lenses used.

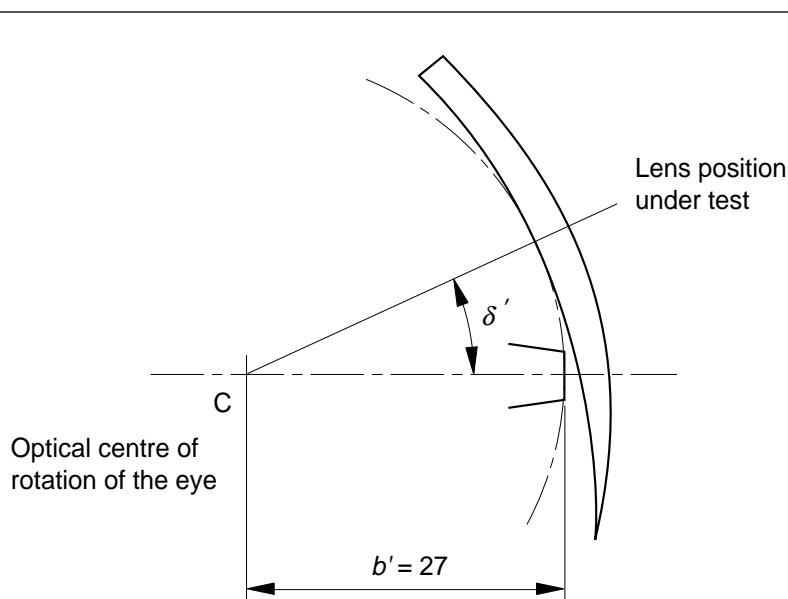

Figure B.1 — Measurement of the optical characteristics in the as-worn position

Bibliography

BS 3062, *Specification for ophthalmic lens materials.*

BS 7394-2, *Complete spectacles — Part 2: Specification for prescription spectacles.*

BSI — British Standards Institution

BSI is the independent national body responsible for preparing British Standards. It presents the UK view on standards in Europe and at the international level. It is incorporated by Royal Charter.

Revisions

British Standards are updated by amendment or revision. Users of British Standards should make sure that they possess the latest amendments or editions.

It is the constant aim of BSI to improve the quality of our products and services. We would be grateful if anyone finding an inaccuracy or ambiguity while using this British Standard would inform the Secretary of the technical committee responsible, the identity of which can be found on the inside front cover. Tel: 020 8996 9000. Fax: 020 8996 7400.

BSI offers members an individual updating service called PLUS which ensures that subscribers automatically receive the latest editions of standards.

Buying standards

Orders for all BSI, international and foreign standards publications should be addressed to Customer Services. Tel: 020 8996 9001. Fax: 020 8996 7001.

In response to orders for international standards, it is BSI policy to supply the BSI implementation of those that have been published as British Standards, unless otherwise requested.

Information on standards

BSI provides a wide range of information on national, European and international standards through its Library and its Technical Help to Exporters Service. Various BSI electronic information services are also available which give details on all its products and services. Contact the Information Centre. Tel: 020 8996 7111. Fax: 020 8996 7048.

Subscribing members of BSI are kept up to date with standards developments and receive substantial discounts on the purchase price of standards. For details of these and other benefits contact Membership Administration. Tel: 020 8996 7002. Fax: 020 8996 7001.

Copyright

Copyright subsists in all BSI publications. BSI also holds the copyright, in the UK, of the publications of the international standardization bodies. Except as permitted under the Copyright, Designs and Patents Act 1988 no extract may be reproduced, stored in a retrieval system or transmitted in any form or by any means – electronic, photocopying, recording or otherwise – without prior written permission from BSI.

This does not preclude the free use, in the course of implementing the standard, of necessary details such as symbols, and size, type or grade designations. If these details are to be used for any other purpose than implementation then the prior written permission of BSI must be obtained.

If permission is granted, the terms may include royalty payments or a licensing agreement. Details and advice can be obtained from the Copyright Manager. Tel: 020 8996 7070.